

TANKER TOP VIEW

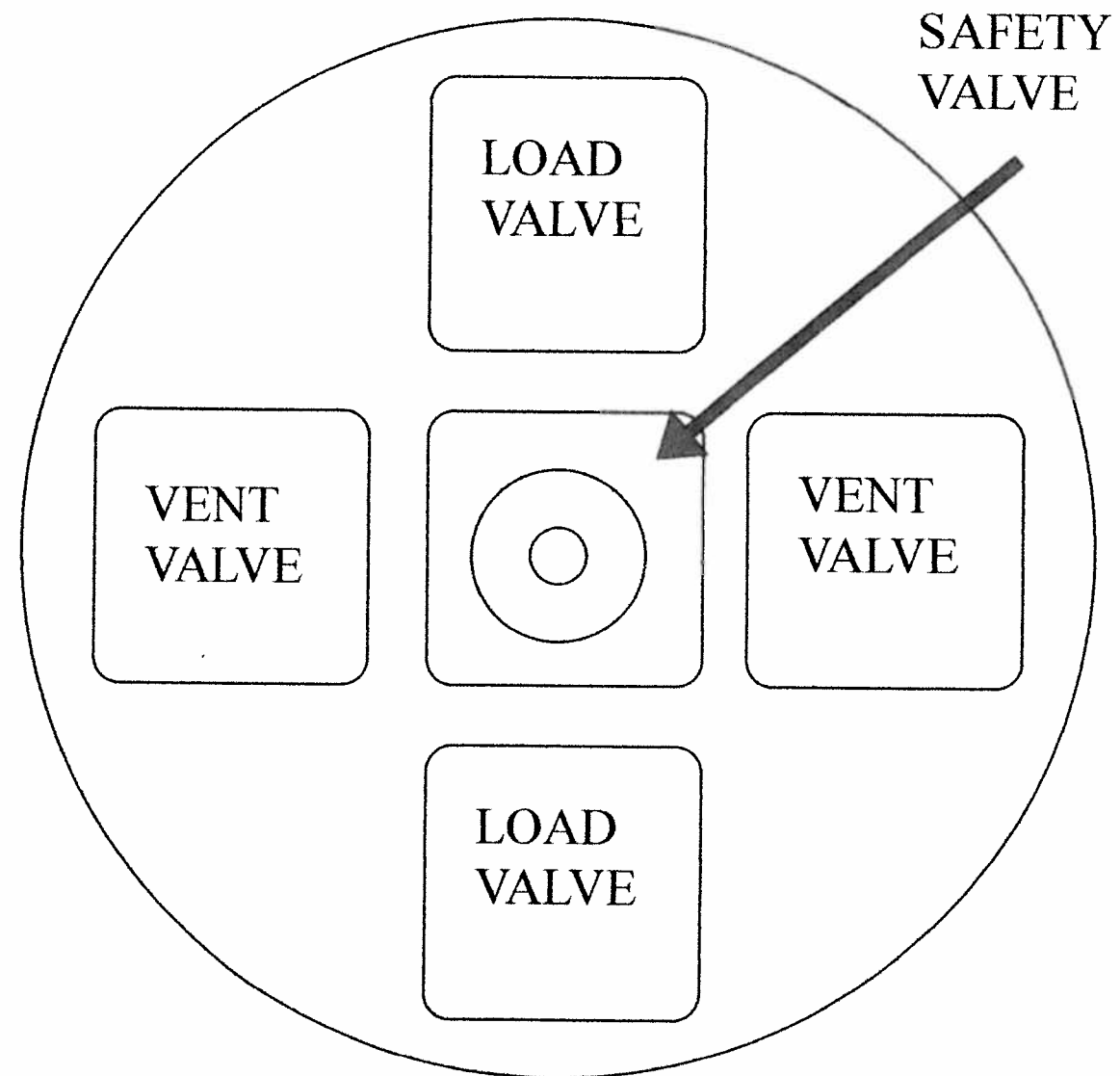

PROX 87739
CTC 105A300W
BLT 12-61DS
SPRG D-3

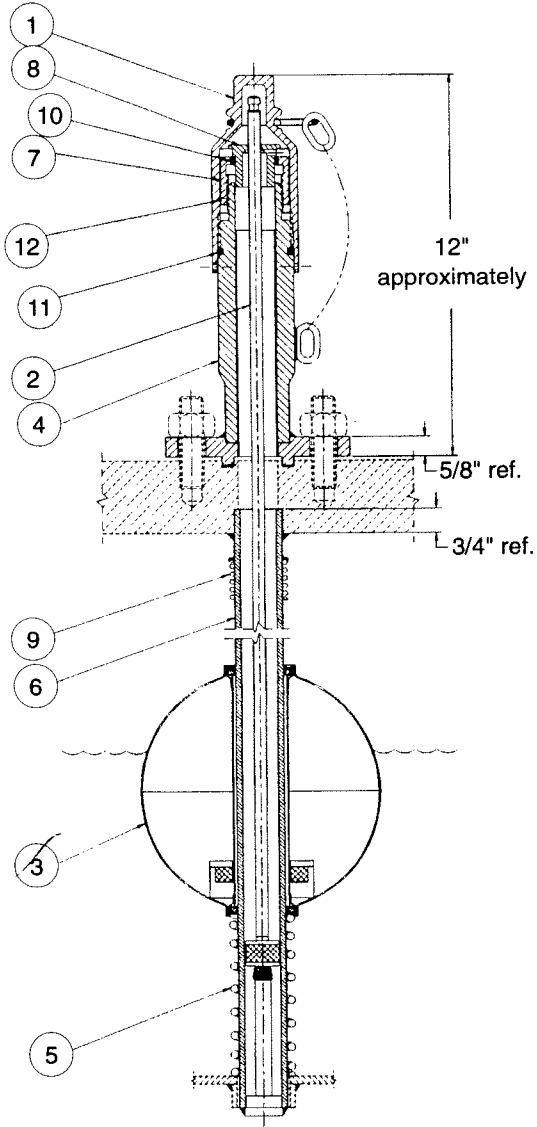

ITEM NO.	QTY.	PART NAME	MATERIAL	PART NO.
1	1	COVER W/CHAIN	DUCTILE IRON/STEEL ⁽⁵⁾	612-1-DI
2	1	GAGE ROD ASSEMBLY ⁽¹⁾	ALUMINUM ⁽²⁾	612-2-AL
3	1	FLOAT ASSEMBLY ⁽³⁾	STAINLESS ⁽⁵⁾	612-3-SS
4	1	BOD ASSEMBLY ⁽⁶⁾	STEEL ⁽⁵⁾	612-4-CS
5	1	BOTTOM SPRING	STAINLESS ⁽⁵⁾	612-5-SS
6	1	GUIDE TUBE ASSEMBLY ⁽⁴⁾	STAINLESS ⁽⁵⁾	612-6-SS
7	1	INSTALLATION CORRECTION NUT	STEEL, PLATED ⁽⁵⁾	612-7-CS
8	1	SPECIFIC GRAVITY ADJUSTMENT BUSHING ⁽¹⁾	PLASTIC	612-8-PS
9	1	TOP SPRING	STAINLESS ⁽⁵⁾	612-55-SS
10	1	"O" RING	SILICONE	612-10-SI
11	1	"O" RING	BUNA-N ⁽⁵⁾	612-11-BN
12	1	SET SCREW	STEEL ⁽⁵⁾	612-12-CS

NOTES: 1 Length, scale, and calibration per application.
 2 Fiberglass available as alternate.
 3 Float diameter of 5", 6" or 7 1/2" selected per application.
 4 Length per application.
 5 Alternate materials available.
 6 Various mountings available.

308-805

QTY	ITEM NO.	DESCRIPTION	UNIT	QTY	ITEM NO.	DESCRIPTION	UNIT	QTY	ITEM NO.	DESCRIPTION	UNIT	QTY	ITEM NO.	DESCRIPTION	UNIT	QTY	ITEM NO.	DESCRIPTION	UNIT
		TANK AREA																	
		MILK FRAME ARRET																	
		TRUCK APP'Y																	
		JACKET APP'Y																	
		SOLE PLATE FORM & LASSIE MOUNT																	
		APPL OF INSULATION																	
TOTAL EST. LIGHT WEIGHT																			

NO.	QTY	DESCRIPTION
1	1	MANHOLE DIAGRAM
2		
3		
4	1	4" DIA. U.S. PIPE

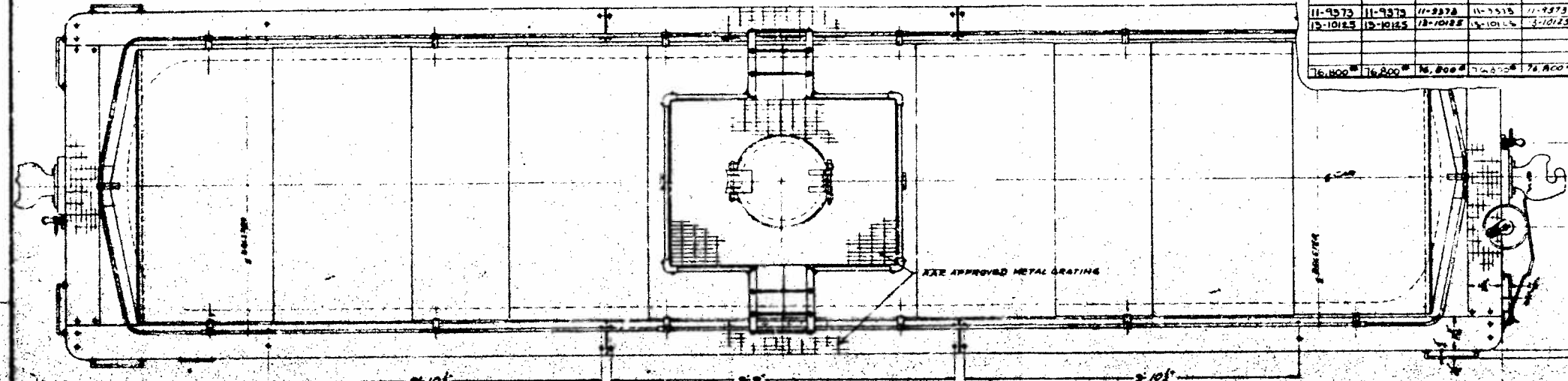

- NOTES:**
- DIMENSIONS SHOWN ARE FOR REFERENCE ONLY.
 - ALL SAFETY APPLIANCE PARTS NOT OTHERWISE IDENTIFIED ARE TO OSHA STANDARDS.
 - ROOM TO O.C. MEETING STANDARDS FOR WELDING REQUIREMENTS.
 - ALLOW FOR APPROPRIATE GAPS OF INSULATION FOR POINTS OF STRUCTURAL INTERFERENCE.

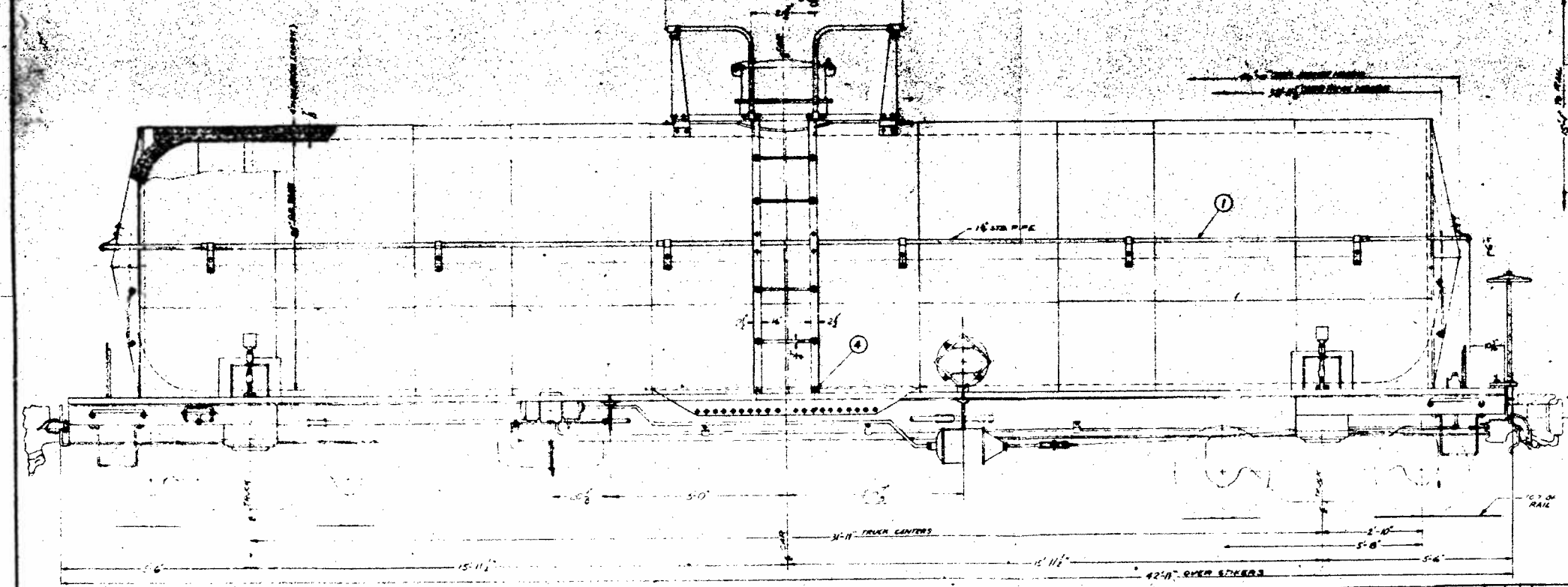
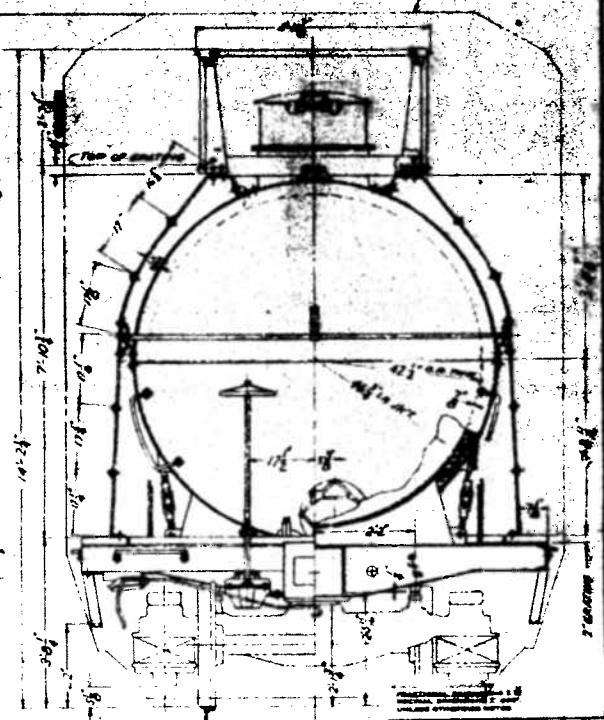

NO.	QTY	DESCRIPTION	UNIT	QTY	ITEM NO.	DESCRIPTION	UNIT	QTY	ITEM NO.	DESCRIPTION	UNIT	QTY	ITEM NO.	DESCRIPTION	UNIT	QTY	ITEM NO.	DESCRIPTION	UNIT
508-B 1504-B 1508-A 1509-A 1487 PTL-94 333-A 333 240 APPRO																			
CARGO CLASS SPEC. WAS 100-10843000 1533-A WAS 11-1371 (EX APPRO. 17-77)																			
INSULATION 8" 11-1044																			

UNION TANK CAR CO.
 CHICAGO, ILL.
 GENERAL ARRANGEMENT
 CAR NO. 59382
 APPRO. 11-1044
 APPRO. 11-1044