

PWGSC

Quality in Environmental Services



**PHASE II ENVIRONMENTAL ASSESSMENT
OF THE
BECKER COCHRAN
ABANDONED MINE SITE**



prepared for:

**Action on Waste Program
Indian and Northern Affairs Canada**

prepared by:

**Environmental Services
Public Works and Government Services Canada**

March 1997



**Public Works and
Government Services
Canada**

**Travaux publics et
Services gouvernementaux
Canada**

Canada

**PHASE II ENVIRONMENTAL ASSESSMENT
OF THE
BECKER COCHRAN
ABANDONED MINE SITE**

prepared for:

**Action on Waste Program
Indian and Northern Affairs Canada**

prepared by:

**Environmental Services
Public Works and Government Services Canada**

March, 1997

EXECUTIVE SUMMARY

A phase II environmental assessment was conducted at the Becker Cochran abandoned mine site (60° 11'03" N, 135° 13'08" W) in July, 1996 by Environmental Services, Public Works and Government Services Canada for the Action on Waste Program, Indian and Northern Affairs Canada. Based on the findings of the Phase I investigation performed in 1993 by DIAND Technical Services, a phase II assessment was conducted to a) identify potential environmental and human health risks associated with the present condition of the mine site, and b) provide recommendations and preliminary cost estimates for remediation of those risks.

A field investigation of the abandoned mine site was conducted to evaluate environmental and human safety concerns with respect to: mine openings and workings; buildings and infrastructure; waste disposal areas; waste rock disposal areas; surface water (including adit and waste rock seepage, and receiving waters); and hazardous and non-hazardous materials on the site.

The results of the investigation concluded that the three mine openings are unstable and are not adequately secured from public and wildlife access. The rails and trestles in front of the lower adit are physically unstable and pose a health and safety hazard to humans visiting the site. An assessment of the acid rock drainage potential shows that the risk to the environment due to the presence of waste rock and adits are currently insignificant. Aesthetic concerns arise from one 2000 litre tank, several 205 litre barrels, timbers, and metal debris scattered primarily in the main gully down drainage of the main site.

Using applicable federal and territorial criteria as well as northern mine reclamation guidelines, the recommendations are to secure all three mine openings using surrounding rock and soil, remove and burn timbers, demolish and bury on-site rails and trestles, and collect and bury on-site all site debris. No further test work is recommended on the waste rock. Additional water quality sampling is required to monitor the impact of the acid generating waste on the receiving environment. It is recommended that every five years a monitoring program be undertaken to obtain water quality data for the spring freshet, middle summer and late fall conditions. Should further development occur on the site, regulatory agencies should ensure that an acid drainage prevention plan is developed which includes detailed measures for handling and disposal of mineralized waste rock.

SUMMARY OF CONCLUSIONS AND RECOMMENDATIONS

ASSESSMENT COMPONENT	RISK	RECOMMENDATION
1. Building, Infrastructure, Equipment		
Rails and Supporting Structure	Health and Safety Concern	Burned and Buried on site
2. Non-Hazardous Waste Material		
Tank and Barrels	Aesthetic Concern	Buried on site
Timbers	Aesthetic Concern	Burned on site
Cans and Misc. Metal Debris	Aesthetic Concern	Buried on site
3. Hazardous Materials		
None		
4. Water Quality		
Mine Seepage	Minor Environmental Risk	monitor - 5yr
Site Drainage	Minor Environmental Risk	monitor - 5yr
Receiving Waters	Minor Environmental Risk	monitor -5yr
5. Waste Rock Disposal Areas		
Waste Rock - 10,120 tonnes	None	None
6. Mine Openings		
1 Adit on Lower level, 2 Adits on Upper Level	Health and Safety Concern	Secure with rock/soils
7. Tailings		
None		

TABLE OF CONTENTS

EXECUTIVE SUMMARY

1.	INTRODUCTION AND BACKGROUND	1
1.1	Location	1
1.2	Overview of Site Development	1
1.3	Site Access	3
2.	PURPOSE AND SCOPE OF WORK	3
3.	SITE ASSESSMENT METHODOLOGY	4
3.1	Assumptions	4
3.2	Assessment criteria	5
3.2.1	Criteria and Guidelines	5
3.2.2	Application of Criteria	6
3.3	Methods	7
3.3.1	Background Information	7
3.3.2	Site Assessment Components	8
3.3.3	Sampling Methods and Quality Assurance	8
4.	ENVIRONMENTAL SETTING	11
4.1	Mineralization	11
4.2	Surface Hydrology	11
4.3	Climate	11
4.4	Vegetation	12
4.5	Fish and Wildlife Resources	12
4.6	Site Topography and Soils	12
4.7	Permafrost	12
5.	SITE DESCRIPTION AND FINDINGS	13
5.1	Buildings, Infrastructure, Equipment	13
5.2	Non-hazardous Waste Materials	13
5.3	Hazardous Materials	13
5.4	Surface Water Quality	14
5.5	Waste Rock Disposal Areas	14
5.6	Mine Openings and Excavations	15
5.7	Tailings	16
6.	CONCLUSIONS	16
6.1	Health and Safety	16

TABLE OF CONTENTS (Con't)

6.2	Environmental Risks	17
6.3	Aesthetic Concerns	17
7.	RECOMMENDATIONS	17
8.	COST ESTIMATES TO IMPLEMENT RECOMMENDATIONS	18

REFERENCES

Figures

Figure 1 Location of Becker Cochran Mine

Tables

Table 1 Non-Hazardous Waste Material
Table 2 Surface Water Samples - Significant Laboratory Results
Table 3 Summary Acid/Base Accounting Test Results
Table 4 Mine Openings

Drawings

Drawing 1 Becker Cochran Mine Site Development and Geological Information
Drawing 2 Lower Site Adit A1
Drawing 2 Upper Site Adit A2
Drawing 2 Upper Site Adit A3

APPENDIX A Determination of Acid Rock Drainage Potential

APPENDIX B Site Photographs

APPENDIX C Analytical Results

1.0 INTRODUCTION AND BACKGROUND

In 1993, assessments of 49 abandoned Yukon mine exploration and development sites were completed under the Arctic Environmental Strategy - Action on Waste program by DIAND Technical Services. These assessments were intended to provide a general overview of historical activities, describe site infrastructure, workings and wastes, describe existing environmental or safety concerns on each site, and provide general recommendations for remediation or mitigation work, as appropriate.

For the Becker Cochran abandoned mine site, the 1993 report recommended further investigation into possible environmental impacts resulting from the previous mining activities. According to that report, the potential areas of concern included: metals leaching into the surface water resulting from acid rock generation of the waste rock; health and safety concerns due to mine openings, site debris, and infrastructure; and aesthetic concerns due to outlying non-hazardous waste materials. No rock, tailings, soil or water samples were collected in this assessment.

In light of these preliminary findings, Indian and Northern Affairs Canada has determined that further investigation is warranted. Environmental Services, Public Works and Government Services Canada was retained to conduct an environmental assessment of the Becker Cochran abandoned mine site to a) identify specific environmental and human safety risks; b) provide clean-up recommendations; and c) provide a Class "D" cost estimate for remediation or mitigation of those risks.

1.1 LOCATION

The Becker Cochran abandoned mine site is located at 60° 11'03" N latitude and 135° 13'08" W longitude approximately 27 km west of the village of Carcross and 2 km northwest of Mount Bell in the Boundary Ranges (Figure 1). The site is between 1500 - 1550 m above sea level.

1.2 OVERVIEW OF SITE DEVELOPMENT

The Becker Cochran property was initially staked in the early 1900's. It was restaked about 1915 by T. Becker and H. Cochran and explored with a 100-foot (30-metre) adit. By 1915 a drift, the No. 2 tunnel, had been driven 350 feet (107 metres) to follow a shear zone consisting of mainly gouge with patches and seams

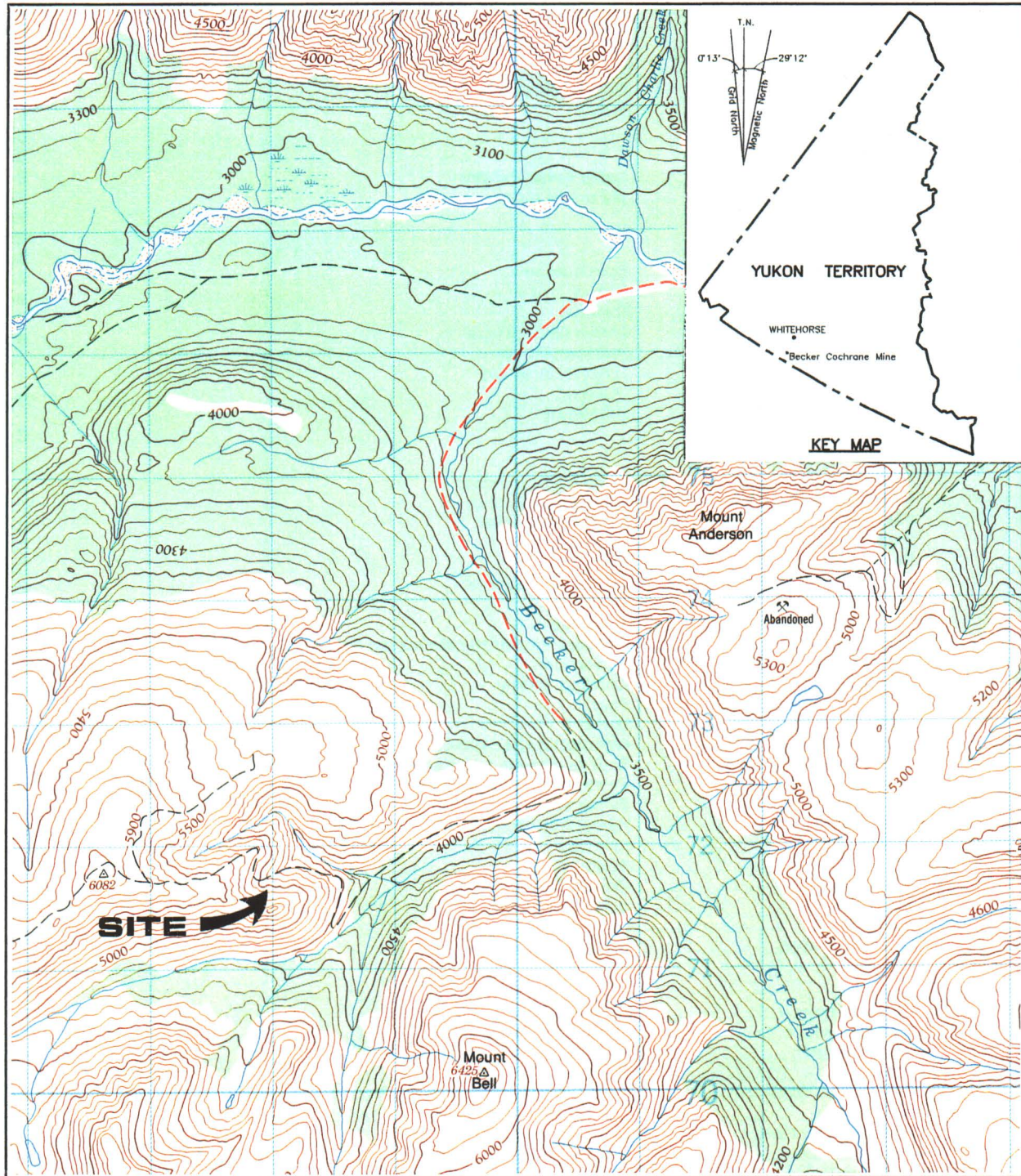

Figure 1. Location of Becker Cochran Mine - 1:50,000, NTS-105 D/3 [Energy Mines and Resources Canada: 1986]

of vein quartz and stibnite. Existing records are unclear, however it is assumed that the No. 2 tunnel was turned off of, or was a continuation of, the 100-foot long adit.

150 feet (46 metres) below the No. 2 tunnel a 172-foot (52-metre) crosscut was driven towards the vein and a drift from the end of the crosscut followed the vein for about 150 feet (46 metres). The crosscut and drift together are called the No. 1 tunnel or the lower tunnel.

A third adit, 35 feet (10 metres) long with a drift 75 feet (23 metres) long, was driven on the upper vein. Approximately 200 feet (61 metres) southeast a fourth adit was driven prior to 1915.

In 1951 a 90-foot (27.4 metre) adit was driven and trenching was conducted with a bull dozer. Records indicate that by 1964 the No. 1 tunnel had been entirely removed by surface trenching and the No. 2 adit had caved near the entrance.

Between 1964 and 1966, extensive trenching occurred and three new adits were driven on the site, for a total of 1415 feet (431.2 metres) of underground development.

In 1977 road construction was completed and the underground rehabilitated. Road construction took place again in 1986.

1.3 SITE ACCESS

Becker Cochran can be reached by traveling approximately 30 km on the Wheaton River Valley road (Annie Lake road) from the Robinson intersection south of Whitehorse on the South Klondike Highway. From the Wheaton River Valley Road at Becker Creek, the site is 9.2 km up a trail accessible by four-wheel-drive vehicle. From the intersection at Becker Creek, the trail parallels the Becker Creek Valley rising approximately 600 m to the site.

2.0 PURPOSE AND SCOPE OF WORK

The following assessment activities were completed:

- Inspection of mine openings and workings, buildings and infrastructure, and waste disposal areas;

- Photo documentation and mapping of relevant site features;
- Sampling of waste rock disposal areas, stained soils, surface water (including adit and waste rock seepage, and receiving waters) and barrel contents;
- Identification and inventory of hazardous and non-hazardous materials on the site;
- Identification of potential or actual environmental pathways and receptors for site contaminants; and
- Assessment of human safety hazards and potential for accidental or deliberate access to hazardous areas.

Upon completion of these activities, preliminary cost estimates were generated to meet the following remediation/mitigation requirements:

- Physical stabilization of waste rock disposal areas;
- Chemical stabilization of the waste rock disposal areas as appropriate to local and background conditions, taking into account impact, on-site resources, and accessibility;
- Sealing of all mine openings;
- Consolidation and landfill of all non-hazardous, non-combustible solid wastes;
- Remediation or removal and disposal of contaminated soils as required to meet the more stringent of: Yukon Government's Contaminated Sites Regulations (1996) Schedule 1; and Canadian Council of Ministers of the Environment's Interim Canadian Environmental Quality Criteria for Contaminated Sites (1991) Commercial/Industrial criteria for soils;
- Removal and disposal of hazardous solid wastes;
- Draining, cleaning and disposal of drums or other containers containing petroleum products or other liquid hazardous wastes;
- Onsite flaring or removal and off-site disposal of petroleum products and other liquid hazardous wastes; and
- Demolition of buildings and infrastructure to foundation level and burning of combustible non-hazardous materials in approved location

3.0 SITE ASSESSMENT METHODOLOGY

3.1 ASSUMPTIONS

The assessment was limited to the area specifically developed or occupied for exploration or mining purposes, and adjacent areas and resources believed to be affected by these activities. Water samples were taken off-site to determine

potential impact to surface water bodies due to mining activities. Access roadways to mine sites were not included in the assessments.

3.2 ASSESSMENT CRITERIA

3.2.1 Criteria and Guidelines

Metal Mining Liquid Effluent Regulations and Guidelines (Environmental Protection Service, Environment Canada, 1977)

The intent of the requirements defined in this document is to limit the discharge of deleterious substances from base-metal, uranium and iron ore mines. These requirements are uniformly applied national standards and intended to provide protection for fish and other aquatic life.

Interim Canadian Environmental Quality Criteria for Contaminated Sites (Canadian Council of Ministers of the Environment, 1992)

The Canadian Council of Ministers of the Environment (CCME) Interim Canadian Environmental Quality Criteria for Contaminated Sites are numerical limits for contaminants in soil and water intended to protect, maintain or improve environmental quality and human health at contaminated sites in general.

CCME criteria include two types of benchmarks for soil and water quality - assessment criteria and remediation criteria. Assessment criteria are approximate background concentrations or approximate analytical detection limits for contaminants in soil and water, and remediation criteria are used as clean-up benchmarks based upon intended land use. Remediation criteria do not address site-specific conditions. They are considered generally protective of human and environmental health for specified uses of soil and water at contaminated sites. The remediation criteria for soil are classified by three land uses:

- 1) Agricultural,
- 2) Residential/Parkland, and
- 3) Commercial/Industrial.

Remediation criteria for water are classified by four uses of water likely of concern at contaminated sites:

- 1) Freshwater aquatic life,
- 2) Irrigation,

- 3) Livestock watering, and
- 4) Drinking water.

Contaminated Sites Regulations (draft) (Yukon Government, 1996)

According to these draft regulations a site is contaminated if it used for agricultural, commercial, industrial, parkland, or residential land use and contains a substance in concentration greater than or equal to:

- (I) the generic numerical soil standard of Schedule 1, or
- (ii) the matrix (pathway specific) numerical soil standards of Schedule 2

and, surface or groundwater used for aquatic life, irrigation, livestock, or drinking water which exceeds a concentration greater than or equal to:

- (I) the generic numerical water standard of Schedule 3, or
- (ii) the local background concentration of that substance in the soil, surface water, or groundwater.

Below 3 metres of the surface, commercial land use criteria is applicable.

Mine Reclamation in Northwest Territories and Yukon (INAC, 1992)

This report defines factors which are to be considered in reclamation of abandoned mine sites operating in northern climates. Factors include:

- open pit and underground mines;
- special mines such as uranium, sand and gravel, and coal;
- waste rock and tailings disposal;
- acid generation and leaching; and
- estimating cleanup costs.

3.2.2 Application of Criteria and Guidelines

The following assessment criteria were used for the Becker Cochran abandoned mine site:

A. Soils:

CCME: Remediation Criteria for Soil -
Commercial/Industrial standard

YUKON RENEWABLE RESOURCES Draft Contaminated Sites Regulations - used for hydrocarbon screening parameters

B. Water:

ENVIR. CANADA: Metal Mining Liquid Effluent Regulations and Guidelines - are compared to seepage from mine openings, and river/stream water quality

BACKGROUND: Downstream water quality results of rivers and streams are compared to the results of upstream (background) water quality.

CCME: Remediation Criteria for Water - Freshwater Aquatic Life guideline for river and stream water quality

[Note: In this screening assessment of water quality, analytical results are primarily compared to background values which may more accurately characterize the local environment.]

C. Mine Clean-Up and Reclamation:

INAC: Mine Reclamation in Northwest Territories and Yukon

3.3 METHODS

3.3.1 Background Information

Available background information was consolidated from the Yukon Chamber of Mines mine records, Whitehorse Public Library, Yukon Archives holdings, and records and reports from the Yukon Renewable Resources Library, Yukon Water Board, DIAND Lands Branch, DIAND Water Resources, and DIAND Library. INAC (1994) provided an overview assessment of the Becker Cochran abandoned mine site to that date. Other published information sources were examined for site or regional information as applicable. On the basis of available information, knowledge gaps regarding existing or potential safety and environmental risks at the site were identified and a site assessment plan was developed.

3.3.2 Site Assessment Components

A site assessment was conducted to identify existing or potential safety and environmental risks on the site. The assessment included the following components:

Waste Rock disposal areas were inspected and sampled by a professional geologist to assess acid rock drainage potential by:

- Identifying waste rock mineralization with potential to release acidic and/or metal-contaminated drainage
- Mapping and logging waste rock, tailings, pit walls and rock faces
- Collecting and field testing representative samples of mine wastes

Mine Openings were inspected and documented to identify closure requirements.

Non-Hazardous Site Debris was inventoried.

Contaminated Soil Areas were measured and sampled to determine the degree and type of contamination and estimate soil volumes for remediation.

Hazardous Materials were inventoried and sampled for analyses of contaminant constituents, as necessary.

Buildings and other Structures were inspected for hazardous materials and assessed for stability.

Borrow Sources were identified and assessed for accessibility and approximate quantity and type of granular material as applicable.

Scale site plans were prepared to identify the dimensions and locations site structures, mine workings and adits, waste rock disposal areas, on-site sampling locations, and any other pertinent information.

3.3.3 Sampling Methods and Quality Assurance

Test Pit Sampling

Test pits were excavated to a depth of about 0.3 to 1.0 m. Horizons in the test pit walls were logged, noting colour/weathering, rock composition, primary and secondary mineralization, particle size distribution, paste pH and paste conductivity, and moisture content. The test pit and was photographed and its location was

marked on the field map.

Approximately 2 kg of rock was collected at each sample site. For test pits showing a homogeneous wall face, a plastic sheet was placed at the bottom of the test pit and the pit wall was cut vertically down with a cleaned shovel. All rock larger than 75 mm in size was discarded. The sample was coned and quartered, discarding opposite quarters, until a 2 kg sample was obtained.

For test pit walls showing clearly-distinguishable horizons (distinguishable by the sulphide and carbonate contents), the horizons were sampled individually.

Water Sampling

Samples were collected from surface streams upstream and downstream of mine related flows, and from representative seeps emanating from waste rock, tailings, pit walls, and/or adits.

250 ml water samples were collected by hand, facing upstream, ensuring that the sample is not contaminated by disturbed sediment, debris and other floating materials. Sample bottles were rinsed three times with water from the sample stream prior to collecting the sample.

2 ml of HNO₃ were immediately added to water samples destined for metals analyses. For analyses of non-metallic parameters, water samples were brim-filled to minimize head space, placed in a cooler, and maintained at 4° C until delivery to the laboratory.

Soil Sampling

Soil lithology was recorded from observations of the side walls of the test pit, and soil samples for both field and laboratory testing were collected. Observations were recorded for each soil sample site, including soil particle size, consistency, colour, moisture, discoloration, stratification, odour, and any other observations of significance.

Samples were collected at depth intervals selected on the basis of stratigraphic observations and anticipated or apparent contamination. The lab samples were collected using disposable latex gloves and decontaminated stainless steel sampling utensils. All samples intended for organic analyses were stored in laboratory-cleaned 250 ml glass jars; samples intended for metals analyses were placed in new "Whirl-Pak" bags. All samples were placed in a cooler for shipment

to the laboratory.

Barrel, Pail, and Above-Ground Storage Tank Sampling

Barrels and pails containing hydrocarbons were sampled with 1.2 m clean hollow glass rods ("drum thieves"), capable of extracting up to 25 ml of product. The rods were inserted into the drum or pail, and the uppermost open tip was sealed to maintain the sample within the rod as it was extracted from the drum or pail. The sampled hydrocarbon was then drained into a 40-ml laboratory-cleaned vial. The extractions were repeated until at least 20-30 ml of product was obtained. The vial was then sealed and placed in a container for shipment to the laboratory. Each used drum thief rod was subsequently destroyed to prevent accidental re-use.

One Above-Ground Storage Tank (AST) was sampled with a stainless steel Bacon bomb sampler. A plunger at the tip of the sampler depressed when contact with the tank bottom was made, allowing petroleum product to enter the body of the sampler. When the sampler was raised, the plunger closed to seal the sampler and allow removal of the sample from the AST. The sampled hydrocarbon was then drained into a 40-ml laboratory-cleaned vial which was then sealed and placed in a container for shipment to the laboratory. The bomb sampler was cleaned with laboratory-grade detergent between sampling events.

Since hydrocarbon samples were collected only for analyses of Total Halides and metals, no cooling or other preservative was required.

Quality Assurance

Quality Assurance (QA) is a set of procedures for ensuring that the results of chemical analyses are, and can be shown to be, accurately representative of field conditions. A complete QA program includes both a field component and a laboratory component.

In addition to the standard sample collection methods outlined above, the field QA measures that were implemented for this assessment study include:

- chain of custody procedures and forms;
- a sample labeling and sample location identification scheme;
- laboratory preparation of all sampling containers;
- laboratory defined sample preservation and shipping procedures; and
- regular maintenance (including re-calibration) and cleaning of field equipment.

Laboratory QA measures included replicate analyses of selected soil and water samples. Replicate analytical results were submitted with each analytical report.

4.0 ENVIRONMENTAL SETTING

4.1 MINERALIZATION

Rhyolite dykes and stocks, and andesite dykes, have intruded granitoid rocks. The dykes are often propylitically to argillically altered and are associated with the mineralized shear zones. The mineralization consists of both massive and disseminated stibnite with lesser amounts of pyrite and sphalerite, and traces of realgar, orpiment, galena, and tetrahedrite in a gangue of quartz and minor barite.

The major commodity identified at this site is antimony. Minor commodities include lead, silver and gold.

4.2 SURFACE HYDROLOGY

Both site and regional drainage are to the northeast draining into Becker Creek and subsequently Wheaton River (see Figure 1). Hydrological and water quality data are not available for the Becker Cochran Stream.

Small seepage volumes (< 2 gallons/min.) were evident from adit 1 and adit 2 (see Figure 2) which drain northwest towards Becker Creek. No site seepage was detected during the site investigation, however seepage through the waste rock is expected due to infiltration from precipitation and regional drainage.

4.3 CLIMATE

The closest climatological information is from the town of Whitehorse (60° 43'N, 135°W at 703m in 1990: Environment, Canada 1990). Total annual precipitation is approximately 261 mm, with the highest snowfall in November and the highest rainfall in August. Approximately 166 mm of precipitation is in the form of rain and 145 cm falls in the form of snow. Mean daily temperatures range from -18.7 °C in January to 14.0 °C in July, with mean annual temperature being -1.0 °C. Due to the higher elevations, the Becker Cochran site most likely has less precipitation and colder temperatures.

4.4 VEGETATION

The site is located within the Boreal Mountains and Plateaus Ecoregion of the Boreal Cordilleran Ecozone. The mine site is within an alpine habitat at an approximate elevation of 1510 m to 1550 m above sea level. The site is characterized by alpine vegetation consisting of lichens, moss, sphagnum, willows, Dryas species and some forbs. Talus slopes above the mine site have little or no vegetation. Disturbed areas at the mine opening and along the access road are dominated by fireweed.

4.5 FISH AND WILDLIFE RESOURCES

Alpine habitats are typically low in both species number and diversity. Bird species noted at the site include bald eagle, ptarmigan and rosy finches. Arctic ground squirrels and pika are the dominant rodent species and support a number of carnivorous species including wolf, coyote, and bear. Ungulates include caribou, moose and mountain sheep. This area is only able to support these species during the short summer period and most animals hibernate or move to lower elevations during the long and cold winters.

4.6 SITE TOPOGRAPHY AND SOILS

The regional topography is mountainous, with a relief of about 1,000 metres between the Wheaton River to some of the higher peaks. The mountains, though steep, are rounded with few cliffs and rock outcrops and can be easily traversed.

Topography below the mine site exhibits typical upper-alpine features such as stone nets and felsenmeer interspersed with hummocky tundra. Steep upper slopes are covered with talus or scree material contributed by freeze-thaw fracturing of sedimentary rock. The slope is uniformly covered with talus; at lower elevations, fractured shale outcrops are interspersed with hummocky flats and gentle slopes. Soils are patchy, thin and peaty, with bedrock usually present within 1 m of the surface.

4.7 PERMAFROST

Becker Cochran is in an area of discontinuous permafrost, although no evidence of permafrost was discovered during the site visit.

5.0 SITE DESCRIPTION AND FINDINGS

5.1 BUILDING, INFRASTRUCTURE, EQUIPMENT

No buildings or equipment were left on site. The only infrastructure are the remains of tracks and trestles which were used to move waste rock from the mine openings. At the lower adit A1, infrastructure includes a trestle which was destroyed and buried along the edge of the adjacent road, and approximately 15 meters of track and 30 metres of twisted rail along the edge of the waste rock embankment. At the upper adit A3, the remains of a trestle, approximately 30 meters in length, is partially buried.

5.2 NON-HAZARDOUS WASTE MATERIALS

The non-hazardous waste materials observed in and around the site are listed in Table 1.

Table 1 Non-Hazardous Waste Materials

Waste Material	Number/ Volume	Location	Comments
2000 litre fuel tank	1	50 m northwest of site in prominent gully	empty with large hole, no staining
205 litre barrel	9	scattered down 500m in northwest gully	empty, no staining
timbers	<10 m ³	scattered around site and in northwest gully	non-preserved, burnable
small cans and metal scraps	<2 m ³	scattered around site and in northwest gully	non-burnable and rusted

5.3 HAZARDOUS MATERIALS

No hazardous materials were observed at the site.

5.4 SURFACE WATER QUALITY

Table 2 identifies the significant findings of the sampling program conducted to determine the potential impact of the site on surface water bodies. Samples were collected from mine opening seepages and site drainage courses and are shown in Figure 2. Upstream samples were also collected to represent the site background conditions for which downstream sample results will be compared. Field measurements of pH and conductivity were taken. Complete analytical results are provided in Appendix B.

Although conductivity results are moderate, to high, metal concentrations were low and below the analytical detection limit for most parameters. For some metals, detection limits are above CCME criteria. No metal parameters yielded high results above background values. The pH results are within acceptable range and are above neutral for all samples.

5.5 WASTE ROCK DISPOSAL AREAS

The waste rock present at the Becker-Cochran property is a result of several generations of underground development and open pit or open cut mining. The

Table 2 Surface Water Samples - Significant Laboratory Results

Sample ID	Sample Location	pH	Conductivity ($\mu\text{s}/\text{cm}$)	Metallic Parameters
BC-WQ-STR-1-1	mine site drainage 175m downstream	7.55	896	low
BC-WQ-STR-2-1	upstream in Becker Creek	7.86	442	low
BC-WQ-STR-1-3	downstream in Becker Creek	7.98	499	low
BC-WQ-A1-1	adit 1 seepage	7.68	1160	low
BC-WQ-A3-1	adit 3 seepage	7.56	700	low

friable nature of the mineralized zone has likely resulted in the caving of the older underground workings and allowed bulldozers to build trenches and open cuts along the mineralized zones.

The fresh unweathered waste rock at the site is likely related to underground

development. Therefore, a tonnage on the order of 11,133 tons (10,120 tonnes) is estimated, assuming a specific gravity of 2.65, a total of 2,390 feet of development, and that the mine openings are 8 feet by 7 feet. The waste rock from the trenches and open cuts consists of weathered mineralized clay rich material.

Seven pits were dug in the waste rock and samples collected for laboratory analysis. Several field paste pH and paste conductivity tests were completed on the site. The sample locations, and results of field paste tests are shown in Figure 2.

Samples BC/WR/P1, BC/WR/P2, and BC/WR/P4 were collected from waste rock at the lower adit. Samples BC/WR/P5, BC/WR/P6, and BC/WR/P7 were collected from the waste rock piles at the upper adits (see Figure 2). Summary Acid/Base Accounting test results are shown in Table 3.

Table 3 Summary Acid/Base Accounting Test Results

Sample #	Paste pH	Total S (%)	SO ₄ (%)	AP	NP	Net NP	NP/AP
WR/P1/1	0.03	0.72	no assay	22.50	-2.31	-24.81	-0.10
WR/P1/2	0.05	1.32	0.63	21.56	8.63	-12.94	0.40
WR/P2/1	7.55	0.12	no assay	3.75	14.63	10.88	3.90
WR/P2/2	4.95	1.44	0.47	30.31	9.13	-21.19	0.30
WR/P2/3	4.80	1.44	0.48	30.00	8.00	-22.00	0.27
WR/P3/2	7.05	1.03	0.12	28.44	44.63	16.19	1.57
WR/P1/3	6.95	1.49	0.24	39.06	58.38	19.31	1.49
WR/P4/1	7.65	0.61	no assay	19.06	86.38	67.31	4.53
WR/P5/1	8.20	0.55	no assay	17.19	94.88	77.69	5.52
WR/P6/1	7.78	0.89	no assay	27.81	94.25	66.44	3.39
WR/P7/1	6.78	3.01	0.56	76.56	17.94	-58.63	0.23
WR/P7/2	7.37	2.46	0.28	68.13	62.88	-5.25	0.92

5.6 MINE OPENINGS AND EXCAVATIONS

Three adits were located "Upper Adit A3" and "Upper Adit A2" are located at elevation 1603, and "Lower Adit A1" at elevation 1557. Table 4 shows the results

of the mine openings investigation. All three openings are unstable and are partially covered.

Table 4 Mine Openings

Adit	Location	Drift Length	Condition
A1	lower site, 1557 elev.	137 meters	unstable condition, timber structure rotting, 2x6 cladding partially blocking entrance
A2	upper site, 1603 elev.	41 meters	unstable condition, drift collapsed 5m from opening
A3	upper site, 1603 elev.	158 meters	unstable condition, adit opening is collapsed and covered by surrounding material and structural timbers

5.7 TAILINGS

No milling of ore was done on site. Therefore, no tailings are present.

6.0 CONCLUSIONS

The primary concern is the health and safety of humans and wildlife relating to the collapsing mine openings and the unstable rails and trestles. A secondary concern is the aesthetic appearance of scattered timbers, metal debris site, and loose tanks and barrels located throughout the site.

6.1 HEALTH AND SAFETY

All the three openings are in unstable condition and are not adequately secured from public and wildlife access. One of the upper adits (A3), had previously collapsed and remains unstable. The second upper adit (A2), has partially collapsed and the access is blocked by rotting timbers. The third adit (A1), is also partially blocked by rotting wood and is in an unstable condition as a result of slumping of loose rocks and soils surrounding the opening.

The rails and trestles in front of the lower adit are physically unstable and pose a health and safety hazard to humans visiting the site.

6.2 ENVIRONMENTAL RISKS

Based on the sampling program conducted at the Becker-Cochran abandoned mine site and Acid Rock Drainage Assessment Report submitted by SRK (Jan, 1997), no environmental risk was identified at the site. Due to the small volume and insignificant acid generating potential of the waste rock, and the low sensitivity of the receiving environment, there does not appear to be a significant risk to the environment at this time.

6.3 AESTHETIC CONCERNS

Aesthetic concerns arise from one 2000 litre tank, several 205 litre barrels, timbers, and metal debris scattered primarily in the main gully below the main site.

7.0 RECOMMENDATIONS

Recommended remediation and management actions are compliant with applicable federal or territorial regulations and criteria, are reliant upon available technology, and are intended to be appropriate for local conditions and sensitivities.

Recommendation 1.

It is recommended that all three mine openings be secured from human and animal access for health and safety reasons. Since site access is good, adits should be covered with surrounding rock and soil using readily available equipment. Timbers should be removed and buried along with other site debris. Should the mine need to be reopened, access to workings is achievable with heavy equipment.

Recommendation 2.

It is recommended that all rails and trestles be demolished and buried on site for health and safety reasons. This can be accomplished using locally available resources and labour and can be buried on-site together with other site debris. Burial can occur by covering waste material with surrounding rock and soil on a clearing adjacent to a rock slope.

Recommendation 3.

No further test work is recommended on the waste rock. Additional water quality sampling is required to monitor the impact of the acid generating waste on the receiving environment. Samples are to be collected at BC/WQ/STR-02-01, and BC/WQ/STR-01-3. The method detection limits used are to meet the CCME criteria for fresh water aquatic life.

It is recommended that every five years a monitoring program be undertaken to obtain water quality data for spring freshet, middle summer and late fall conditions.

Should further development occur on the site, regulatory agencies should ensure that an acid drainage prevention plan is developed which includes detailed measures for handling and disposal of mineralized waste rock.

Recommendation 4.

It is recommended that site debris be collected and buried on-site for aesthetic reasons. The 2000 litre tank, 9 barrels, structural timbers, and miscellaneous metal debris, surrounding the site can be collected using locally available labour and resources.

8.0 COST ESTIMATES TO IMPLEMENT RECOMMENDATIONS

The estimated cost to implement the recommendations is provided under separate cover.

REFERENCES

- Canadian Council of Ministers of the Environment, 1991.** Interim Canadian Environmental Quality Criteria for Contaminated Sites. The National Contaminated Sites and Remediation Program.
- DIAND Technical Services, 1993.** Assessment Report, 105 D-03-2, Becker Cochran Abandoned Mine Assessment. Prepared for Indian and Northern Affairs Canada.
- Ecological Stratification Working Group, November, 1996.** A National Ecological Framework for Canada. Produced by Centre for Land and Biological Resources Research and Research Branch, Agriculture and Agri-Food Canada; and, State of the Environment Directorate, Environmental Conservation Service, Environment Canada.
- Energy, Mines & Resources, 1974,** National Atlas of Canada. 4th Edition.
- Environment Canada Atmospheric Environment Service.** Canadian Climate Normals. 1961-1990.
- Environment Canada Atmospheric Environment Service.** Canadian Climate Normals. 1951-1980.
- Environmental Protection and Assessment Branch, June 1996.** Draft, Contaminated Sites Regulations. Yukon Renewable Resources.
- Omni Resources Inc. 1987.** Project Overview of Omni Resources Inc's Skukum Creek Project.
- Steffen, Robertson, and Kirsten (B.C.), 1992.** Mine Reclamation in Northwest Territories and Yukon. Prepared for Northern Water Resource Studies, Northern Affairs Program, DIAND. Report No. QS-8476-000-EF-A1, Minister of Supply and Services Canada.

APPENDIX A

Determination of Acid Rock Drainage Potential

P118105

**BECKER COCHRAN
ACID ROCK DRAINAGE
ASSESSMENT REPORT**

TABLE OF CONTENTS

1.0	INTRODUCTION	B-1
2.0	GEOLOGY AND MINERALIZATION	B-2
3.0	WASTE ROCK DISPOSAL AREAS	B-2
3.1	Description	B-2
3.2	Samples	B-3
3.3	Analytical Results	B-3
4.0	EXISTING AND POTENTIAL ACID ROCK DRAINAGE CONDITIONS .	B-5
5.0	REMEDIATION OPTIONS	B-5
6.0	CONCLUSIONS AND RECOMMENDATIONS	B-8
6.1	Conclusions	B-8
6.2	Recommendations	B-8
7.0	REFERENCES	B-8

LIST OF TABLES

TABLE 1	Becker Cochran Waste Rock Sample Descriptions	B-10
TABLE 2	Becker Cochran Waste Rock Sample ABA and ICP Results	B-11
TABLE 3	Becker Cochran Water Quality Results	B-12

SITE MAP

**BECKER COCHRAN
ACID ROCK DRAINAGE
ASSESSMENT REPORT**

1.0 INTRODUCTION

This site specific report has been prepared in conjunction with a *Phase II Environmental Assessment of the Becker Cochran Abandoned Mine Site*, prepared by Environmental Services, Public Works and Government Services Canada (PWGSC). The reader is directed to that report for a comprehensive environmental assessment of the Becker Cochran site.

The Becker Cochran site is located in the Wheaton River district, approximately 27 Km west of the Village of Carcross, Yukon Territory. The site is accessible by vehicle.

Mining related disturbances observed during the site assessment consist of three adits and two areas of waste rock. The waste rock present at the Becker Cochran site is the result of several generations of exploration and development. Underground development occurred between 1909 and 1915, in 1951 and most recently between 1964 and 1966 (Yukon Minfile 105D 027).

The site is above the treeline and is covered with short grasses and alpine vegetation. It is located at the head of an ephemeral tributary of Becker Creek, which flows into Wheaton River.

This report reviews the existing, and the potential for, acid rock drainage (ARD) conditions at the Becker Cochran site and provides recommendations for remediation. This site specific report is part of the *Acid Rock Drainage Review Report, Yukon Abandoned Mine Site Assessments*, prepared by Steffen, Robertson and Kirsten (SRK). The reader is directed to that report for detail regarding the scope of work, site assessment methodology, ARD remediation options and the evaluation of potential remediation options.

2.0 GEOLOGY AND MINERALIZATION

The geology of the area consists of rhyolite dykes and older andesites that intrude and overlay granitoid rocks. The dyke rocks are often propylitically to argillically altered and are associated with the mineralized shear zones. The mineralization in the clay altered shear zones consists of both massive and disseminated stibnite (Sb_2S_3) with lesser amounts of pyrite (FeS_2) and sphalerite ($(\text{Zn,Fe})\text{S}$), and traces of realgar (AsS), orpiment (As_2S_3), galena (PbS) and tetrahedrite ($(\text{Cu,Fe})_{12}\text{Sb}_4\text{S}_{13}$) in quartz (SiO_2) and minor barite (BaSO_4) (GSC Memoir 312, p. 132).

The major commodity identified at this site is antimony. Minor commodities include lead, silver and gold.

3.0 WASTE ROCK DISPOSAL AREAS

3.1 Description

The volume of waste rock produced from all the historical underground development is in the order of 10,000 tonnes. The assumptions made to derive this estimate are:

- a specific gravity of 2.65;
- a total of 730 metres of underground development; and,
- 2.4 by 2.1 metres mine openings.

Approximately 20% of the surface area of the waste rock piles is stained reddish from secondary iron minerals and 12% is composed of yellow/green coloured clay from the mineralized shear zones. It is estimated that there is between 3000 and 4000 tonnes of mineralized waste rock at the Becker Cochran site, assuming that the proportion of mineralized to unmineralized waste rock on the surface is representative of the total waste rock pile. The distribution of mineralization in the waste rock piles is shown on a site map, Drawing 2.

3.2 Samples

Seven pits were dug in the waste rock, from which twelve samples were gathered for laboratory analysis. Several paste pH and paste conductivity tests were completed on the site. The sample locations and field paste test results are shown on the site map.

Samples (BCWR/*) P1/1, P1/2, P2/1, P2/2, P2/3, P3/1, P3/2 and P4 were collected from waste rock at the lower adit. Samples (BCWR/*) P5, P6, P7/1, and P7/2 were collected from waste rock located at the upper adits. Pits P1 and P2 were collared in reddish iron-stained waste rock. Pits P4 and P7 were collared in the clay mineralized waste rock. The remaining pits were collared in relatively unaltered waste rock. The test pit logs are summarized in Table 1.

Samples were collected of the water discharging from the lower adit (BCWQ/A1-01) and the upper west adit (BCWQ/A3-01). No water was discharging from the upper east adit. No seeps from the waste rock piles were observed.

Sample BCWQ/STR-01-01 was collected 175 metres below the mine workings from a spring in the drainage channel of the mine site. Sample BCWQ/STR-01-3 was collected from the same tributary 800 metres below the mine site, where the access road crosses the creek. Sample BCWQ/STR-02-01 was collected to determine the background water quality for the area. It was obtained upstream in a branch that joined the tributary approximately 300 metres below the site.

3.3 Analytical Results

Results of geochemical analyses of waste rock samples are provided in Table 2 and the analytical results for the water samples are provided in Table 3.

Paste Parameters

Laboratory paste pH values for the 12 waste rock samples ranged from 3.7 to 8.0. The lowest paste pH values were measured in samples collected from test pit P1, with values of 3.7 and 4.8, indicating that this material is currently generating acid. Moderate field paste conductivities of 510 $\mu\text{S}/\text{cm}$ and 880 $\mu\text{S}/\text{cm}$ indicated that some stored oxidation products were present in the waste.

The paste pH of the surface material at sample pit P2 was 7.6. However, the underlying material in the pile had paste pH values below 5, indicating acidic conditions.

Material from pits P3, P4, P5, P6, and P7 had neutral to alkaline paste pH values (6.8 to 8.2) and are not generating acid. The paste conductivities varied from 70 $\mu\text{S}/\text{cm}$ to 1050 $\mu\text{S}/\text{cm}$ (except for pit P3 for which this parameter was not measured).

Acid Base Accounting

Waste samples collected from pits P1, P3, P7 and the deeper sample from pit P2 had Neutralization Potential to Acid Potential (NP:AP) ratios below 1.6, indicating that the material is potentially acid generating. Material in pits P4, P5, P6, and from the top of pit P2 had a low potential for acid generation.

Metals Concentrations

Most of the waste rock contained elevated concentrations of arsenic and antimony. Some samples also contained high concentrations of zinc and lead. The highest metal concentrations were found in samples collected from pits P6 and P7, at the upper waste rock pile.

Water Quality

Discharge water from the adits had laboratory pH values greater than 7.5 and conductivities of 1160 $\mu\text{S}/\text{cm}$ and 700 $\mu\text{S}/\text{cm}$, respectively for the lower and upper west portals. Total alkalinity was approximately 200 mg/L and acidity was approximately 12 mg/L. Sulphate concentrations were 460 mg/L in sample A1-01 and 182 mg/L in the sample A3-01.

Metal concentrations in stream water samples were generally below the limits of detection. Concentrations of iron and zinc were below CCME freshwater aquatic life criteria. The method detection limits for arsenic, cadmium, copper and lead were higher than the CCME guidelines for these elements.

Metal concentrations in the adit discharge samples were below the criteria specified in Schedule 1 of the Metal Mining Liquid Effluent Regulations and Guidelines.

4.0 EXISTING AND POTENTIAL ACID ROCK DRAINAGE CONDITIONS

Sample analysis of the waste rock suggests that the area exhibiting secondary iron mineralization is currently generating acid (paste pH is below 4). There are approximately 2,000 tonnes of the waste rock at the Becker Cochran site currently generating acid, assuming that the iron stained acid generating material's distribution observed on the surface is representative of the whole pile.

Despite relatively high concentrations of arsenic, antimony, lead, and zinc in the waste rock, concentrations of these metals were not detected in the stream below the site. It appears that during much of the year the streambed immediately below the site is dry. Runoff from the waste piles containing dissolved metals likely seeps into the ground before reaching the flowing stream approximately 50 metres below. These results are based on samples taken during a single day in the summer. Additional soluble metal constituents may be washed from the waste during high rainfall events or the spring freshet.

There is a potential that acid generating conditions will increase to approximately one third of the waste. The waste has been sitting on site for at least 30 years, however, and it is unlikely that the rate of acid generation will increase from current levels. The waste does not appear to be significantly impacting the stream water.

Waters discharging from both the upper (A3) and lower (A1) adits are neutral and contain moderate sulphate concentrations, indicating that oxidation of sulphides is occurring in the adits but that sufficient buffering capacity exists to neutralize the acidity produced.

5.0 REMEDIATION OPTIONS

Typical reclamation and control options for acid generating mine waste and mine openings include:

- source control which includes limiting further oxidation, for instance, by placing the waste under water thus preventing oxygen entry;

- migration control which limits the mobility of oxidation products, for example, by reducing infiltration to the waste by placing a low permeability cover; and,
- release control by collecting and treating contaminated flows prior to discharge.

Collection and treatment of the runoff from the Becker Cochran site is not considered a viable option due to the lack of surface water discharging from the site, the remote location, and the high cost of operating a treatment facility. Relocation of the waste rock was not considered since there is no secure placement location readily available, such as underground workings or an open pit.

Covering it with soil and/or geomembrane to control future acid generation was considered as a potential remediation option. This option is compared to the "do nothing" option in the table below.

The waste rock piles at the Becker Cochran site do not represent a health and safety risk, except to workers during the placement of the cover. The recent site visit indicated that the waste rock currently has little impact on the downstream water quality. Should a cover be placed a moderate risk to the ecosystem will result, since disturbing the waste could cause a short term release of soluble metal constituents into the receiving environment, and an additional site would be disturbed to provide the cover material. The risk to the environment is ranked slightly higher if no remediation action were to be undertaken since the zone of oxidation may increase in the future. However, the waste rock piles are located at a moderately dry site in an area that has anomalous background mineralization and sulphides, thus the impact on the receiving environment from the small volume of waste rock would be low.

Exploration on the site would not be impeded by either remediation measure.

Matrix for Evaluating Applicable/Potential Remediation

Option versus Evaluation Criteria	Becker Cochran			
	Collect and Treat	Relocate	Cover	Leave as is
Public Health and Safety 5 = provides full protection of public 1 = provides no protection of public	not applicable	not applicable	5	5
Worker Health and Safety 5 = relative low risk to workers 1 = high risk to workers	not applicable	not applicable	2	5
Ecosystem Preservation and Protection 5 = relative low risk to environment 1 = relative high risk to environment	not applicable	not applicable	4	3
Impact on Mineral Resource 5 = allows for continued exploration 1 = impedes continued exploration	not applicable	not applicable	5	5
Direct Costs (mobilization & materials) 5 = relative low cost 1 = relative high cost	not applicable	not applicable	3	5
Monitoring and Maintenance Costs 5 = relative low cost 1 = relative high cost	not applicable	not applicable	3	3
Acceptability 5 = positive response anticipated 1 = negative response anticipated	not applicable	not applicable	4	3
Total Score	0	0	26	29

Due to the technical difficulties associated with the terrain, the cost to cover the waste rock would be relatively high compared to leaving the pile "as is". Maintenance of the cover would also be required. Monitoring of the receiving water would be required for either option.

Covering and revegetation of the waste rock pile would improve the aesthetic appearance of the site and is therefore ranked slightly higher for acceptability.

6.0 CONCLUSIONS AND RECOMMENDATIONS

6.1 Conclusions

The above evaluation illustrates that "do nothing" is the preferred option for the Becker Cochran waste rock piles. This is supported by the fact that the waste rock at the Becker Cochran site has been exposed to weathering for more than 30 years without any apparent negative impact on the receiving environment. Therefore, with respect to ARD, no remediation action at Becker Cochran is required.

6.2 Recommendations

No further test work is recommended on the waste rock. Additional water quality sampling may be required to monitor the potential impact of the acid generating waste on the receiving environment. Samples should be collected at BCWQ/STR-02-01, and BCWQ/STR-01-3. The method detection limits used are to correspond to the CCME freshwater aquatic life criteria.

It is recommended that every five years a monitoring program be undertaken to obtain water quality data for spring freshet, middle summer and late fall conditions.

7.0 REFERENCES

Canadian Council of Ministers of the Environment, 1991. Interim Canadian Environmental Quality Criteria for Contaminated Sites. The National Contaminated Sites and Remediation Program.

DIAND Technical Services, 1993. Assessment Report 105D-03-2, Becker Cochran Abandoned Mines Assessment. Indian and Northern Affairs Canada.

DIAND, Exploration and Geological Services Division, 1992. Yukon Minfile 105D 027, Becker Cochran.

Holstein, R., Aurum Geological Consultants Inc. Geological, Geochemical and Airphoto Interpretation Report on the POP 71-104 claims. Whitehorse Mining District, Assessment Report No. 091809.

Wheeler, J.O., 1961. Whitehorse Mpa-Area, yukon Territory, 105D Geological Survey of Canada Memoir, 312.

MMLE, 1977. Metal Mining Liquid Effluent Regulations. Canada Gazette Part II, Vol. III, No. 5. Regulations, codes and Protocols Report No. EPS 1-W-77-1, Ministry of Supply and Services Canada.

TABLE 1
Becker Cochran Waste Rock Sample Descriptions

Sample ID	Sample Description
BCWR/P1/1	Collected below the roadbed material at the lower adit. Mixture of rhyolite, shale and mineralized shear material. Sample collected from 22 to 58 cm below ground surface.
BCWR/P1/2	18 cm thick iron oxide cemented band, collected below BCWR/P1/1.
BCWR/P2/1	30% reddish brown stained sand in the waste rock below the lower adit, 70% 2cm x 5cm granitic rocks, crusty 8 cm thick surface.
BCWR/P2/2	Reddish brown stained granitic rocks, 20 cm thick, collected below BCWR/P2/1.
BCWR/P2/3	Weakly oxidized rhyolite and fault gouge material, 32 cm deep.
BCWR/P3/1	Collected from the unmineralized waste rock below the lower adit. 5 cm thick band of buff coloured rhyolite, 90% grey sand.
BCWR/P3/2	Cobbles and pebbles of rhyolite and granite with oxidized surfaces. Rhyolite oxides are yellow/green to a red brown. Sample collected below BCWR/P3/1.
BCWR/P4	Yellowish coloured sand and gravel, with greenish yellow fines at the contact of the unmineralized waste rock with the clay rich mineralized waste rock below the lower adit.
BCWR/P5	Unmineralized andesite, light brown coloured sand. Collected in the waste rock below the upper adits.
BCWR/P6	Mixed waste rock. 30% orange brown oxidized lenses and patches of clay. Collected in the waste rock below the upper adits.
BCWR/P7/1	Sticky, clay cap 2 to 5 cm thick, on 10 cm of oxidized orange brown sand with greenish yellow pebbles. Collected in the clay rich mineralized waste rock below the upper adits.
BCWR/P7/2	Waste rock at upper adits. 15 cm of unoxidized rhyolite / andesite, collected below BCWR/P7/1.

TABLE 2 Becker Cochrane Waste Rock ABA and ICP Results

Parameter	Units	Sample Number BCWR											
		P1/1	P1/2	P2/1	P2/2	P2/3	P3/1	P3/2	P4	P5	P6	P7/1	P7/2
Field Paste pH		3.40	3.62	na	na	na	na	na	7.41	8.50	7.61	5.88	7.70
Field Cond	µS/cm	510	880	na	na	na	na	na	330	70	110	1050	290
Lab Paste pH		3.70	4.80	7.55	4.95	4.80	7.05	6.95	7.65	8.20	7.78	6.78	7.37
Total Sulfur	%	0.72	1.32	0.12	1.44	1.44	1.03	1.49	0.61	0.55	0.89	3.01	2.46
Sulfate	%	na	0.63	na	0.47	0.48	0.12	0.24	na	na	na	0.56	0.28
AP		22.5	21.6	3.8	30.3	30.0	28.4	39.1	19.1	17.2	27.8	76.6	68.1
NP		-2.3	8.6	14.6	9.1	8.0	44.6	58.4	86.4	94.9	94.3	17.9	62.9
NET NP		-24.8	-12.9	10.9	-21.2	-22.0	16.2	19.3	67.3	77.7	66.4	-58.6	-5.3
NP/AP		<0.1	0.40	3.90	0.30	0.27	1.57	1.49	4.53	5.52	3.39	0.23	0.92
Aluminum	%	0.22	0.22	0.20	0.22	0.21	0.29	0.27	0.25	0.27	0.39	0.43	1.02
Antimony	ppm	3845	1097	19	134	111	232	326	10	12	270	>10000	457
Arsenic	ppm	2022	3148	104	2472	2575	1701	955	100	49	1288	4316	4999
Barium	ppm	564	327	139	399	367	273	346	471	435	316	184	176
Beryllium	ppm	<0.1	<0.1	<0.1	<0.1	<0.1	<0.1	<0.1	<0.1	<0.1	<0.1	<0.1	<0.1
Bismuth	ppm	<1	<1	<1	<1	<1	<1	<1	<1	<1	<1	<1	<1
Cadmium	ppm	23.4	25.9	<0.1	22.6	24.4	<0.1	<0.1	<0.1	<0.1	<0.1	36.0	19.2
Calcium	%	0.09	1.26	0.68	1.03	1.04	1.66	2.22	3.29	3.75	3.33	1.81	3.00
Chromium	ppm	70	84	98	84	84	95	84	91	59	45	56	36
Cobalt	ppm	2	5	2	5	5	11	8	7	7	13	16	25
Copper	ppm	10	20	8	9	9	40	14	12	17	132	65	107
Gallium	ppm	<1	<1	<1	<1	<1	<1	<1	<1	<1	<1	<1	<1
Iron	%	1.31	2.47	0.80	1.80	1.85	2.82	2.21	1.96	1.95	3.12	3.69	5.20
Lead	ppm	98	28	20	14	16	<1	<1	<1	32	459	159	54
Lithium	ppm	<1	<1	<1	<1	<1	3	2	2	3	2	7	22
Magnesium	%	0.02	0.13	0.11	0.12	0.11	0.69	0.63	0.66	0.61	0.77	0.52	1.23
Manganese	ppm	33	446	304	323	256	1017	761	941	960	1312	1054	1637
Molybdenum	ppm	10	16	7	7	8	18	14	12	9	14	66	36
Nickel	ppm	4	12	8	9	9	38	16	17	14	23	32	40
Potassium	%	0.21	0.19	0.21	0.20	0.19	0.21	0.20	0.21	0.22	0.21	0.16	0.20
Phosphate	ppm	480	700	80	610	620	750	580	650	750	840	560	600
Silver	ppm	1.4	1.4	0.5	0.3	0.4	0.7	0.8	0.7	0.8	0.8	1.3	0.6
Sodium	%	<0.01	<0.01	0.02	<0.01	<0.01	<0.01	<0.01	0.02	<0.01	<0.01	<0.01	<0.01
Strontium	ppm	96	78	47	123	94	93	91	104	176	177	135	184
Thorium	ppm	<1	<1	7	<1	<1	<1	<1	<1	<1	<1	<1	<1
Tin	ppm	<1	<1	<1	<1	<1	2	<1	<1	<1	2	2	4
Titanium	%	<0.01	<0.01	<0.01	<0.01	<0.01	<0.01	<0.01	<0.01	<0.01	<0.01	<0.01	<0.01
Tungsten	ppm	3	4	6	4	4	3	3	4	2	<1	2	<1
Uranium	ppm	1	<1	<1	<1	<1	<1	<1	<1	<1	<1	<1	<1
Vanadium	ppm	2.9	4.7	2.1	3.8	3.8	13.6	8.0	10.5	10.5	18.5	18.8	53.0
Zinc	ppm	103	210	43	85	67	169	129	56	105	994	755	366

AP = Acid Potential in tonnes CaCO₃ equivalent per 100 tonnes of material

NP = Neutralization Potential in tonnes CaCO₃ equivalent per 1000 tonnes of material

Net NP = Net Neutralization Potential = tonnes CaCO₃ equivalent per 1000 tonnes of material

na = no assay / analysis

< = lower detection limit

> = upper detection limit

Steffen Robertson and Kirsten
February, 1997

TABLE 3 **Becker Cochran Water Quality Results**

Parameter	Units	Sample Number BCWQ/				
		STR-01-01	STR-02-01	STR-01-3	A1-01	A3-01
Field Cond	(umhos/cm)	na	na	na	980	na
Field pH		na	na	na	8.5	na
Lab Cond	(umhos/cm)	896	442	499	1160	700
Lab pH		7.55	7.86	7.98	7.68	7.56
Acidity (to pH 8.3)CaCO3	mg/L	13.7	3.9	2	12.5	11.6
Alkalinity-Total CaCO3	mg/L	177	63.7	90.2	231	199
Sulphate SO4	mg/L	342	159	173	460	182
Aluminum T-Al	mg/L	<0.2	<0.2	<0.2	<0.2	<0.2
Antimony T-Sb	mg/L	0.2	<0.2	<0.2	<0.2	<0.2
Arsenic T-As	mg/L	<0.2	<0.2	<0.2	<0.2	<0.2
Barium T-Ba	mg/L	0.04	0.07	0.07	0.02	0.04
Beryllium T-Be	mg/L	<0.005	<0.005	<0.005	<0.005	<0.005
Bismuth T-Bi	mg/L	<0.1	<0.1	<0.1	0.1	<0.1
Boron T-B	mg/L	<0.1	<0.1	<0.1	<0.1	<0.1
Cadmium T-Cd	mg/L	<0.01	<0.01	<0.01	<0.01	<0.01
Calcium T-Ca	mg/L	107	52.2	62.8	132	90.8
Chromium T-Cr	mg/L	<0.01	<0.01	<0.01	<0.01	<0.01
Cobalt T-Co	mg/L	<0.01	<0.01	<0.01	<0.01	<0.01
Copper T-Cu	mg/L	<0.01	<0.01	<0.01	<0.01	<0.01
Iron T-Fe	mg/L	<0.03	<0.03	<0.03	<0.03	<0.03
Lead T-Pb	mg/L	<0.05	<0.05	<0.05	<0.05	<0.05
Lithium T-Li	mg/L	0.03	<0.01	0.02	0.05	0.02
Magnesium T-Mg	mg/L	56	19.8	21.8	77	34.3
Manganese T-Mn	mg/L	<0.005	<0.005	<0.005	<0.005	0.01
Molybdenum T-Mo	mg/L	<0.03	<0.03	<0.03	<0.03	<0.03
Nickel T-Ni	mg/L	<0.02	<0.02	<0.02	<0.02	<0.02
Phosphorus T-P	mg/L	<0.3	<0.3	<0.3	<0.3	<0.3
Potassium T-K	mg/L	3	<2	<2	2	<2
Selenium T-Se	mg/L	<0.2	<0.2	<0.2	<0.2	<0.2
Silicon T-Si	mg/L	2.32	2.8	3.04	2.04	2.99
Silver T-Ag	mg/L	<0.01	<0.01	<0.01	<0.01	<0.01
Sodium T-Na	mg/L	8	4	5	13	4
Strontium T-Sr	mg/L	1.96	0.439	0.686	4.12	1.54
Thallium T-Tl	mg/L	<0.1	<0.1	<0.1	<0.1	<0.1
Tin T-Sn	mg/L	<0.03	<0.03	<0.03	<0.03	<0.03
Titanium T-Ti	mg/L	<0.01	<0.01	<0.01	<0.01	<0.01
Vanadium T-V	mg/L	<0.03	<0.03	<0.03	<0.03	<0.03
Zinc T-Zn	mg/L	0.008	<0.005	<0.005	<0.005	0.032

na = no assay / analysis

< = lower detection limit

APPENDIX B

Site Photographs

BECKER COCHRAN
Photographic Record

July 23, 1996

Photos	Description
B.C. # 1	Waste Rock, Below Lower Adit
B.C. # 2	Track and Debris
B.C. # 3	Miscellaneous Pipe, Rails and Debris
B.C. # 4	Wood Debris
B.C. # 5	Lower Adit - A1
B.C. # 6	West Middle Adit - A 3
B.C. # 7	East Middle Adit - A 2
B.C. # 8	Road and Remains of Trestle
B.C. # 9	View from Upper Adits to Lower Site



Photo # 1 - Waste Rock, Below Lower Adit



Photo # 2 - Track and Debris



Photo # 3 - Miscellaneous Pipe, Rails and Debris



Photo # 4 - Wood Debris



Photo # 5 - Lower Adit - A 1



Photo # 6 - West Middle Adit - A 3



Photo # 7 - East Middle Adit - A 2



Photo # 8 - Road and Remains of Trestle



Photo # 9 - View from Upper Adits to Lower Site

APPENDIX C
Analytical Results

PUBLIC WORKS AND
GOVERNMENT SERVICES
laboratories

02673rd. NOV -7 1996



CHEMICAL ANALYSIS REPORT

Date: August 28, 1996

ASL File No. G3396

Report On: 762186 Water Analysis

Report To: **Public Works & Gov't Services**
Environmental Services
204-1166 Alberni Street
Vancouver, BC
V6E 3W5

Attention: **Mr. Tim Sackmann**, Manager, Contaminated Sites

Received: July 25, 1996

ASL ANALYTICAL SERVICE LABORATORIES LTD.
per:

Heather A. Ross
Heather A. Ross, B.Sc.
Project Chemist

Frederick Chen
Frederick Chen, B.Sc.
Supervisor, Trace Metals Lab





RESULTS OF ANALYSIS - Water

File No. G3396

	BC-WQ-STR-01-01 96 07 23	BC-WQ-STR-02-01 96 07 23	BC-WQ-STR-01-03 96 07 23	BC-WQ-A1-1 96 07 23	BC-WQ-A3-1 96 07 23
Physical Tests					
Conductivity (umhos/cm)	896	442	499	1160	700
pH	7.55	7.86	7.98	7.68	7.56
Dissolved Anions					
Acidity	CaCO3 13.7	3.9	2.0	12.5	11.6
Alkalinity - Total	CaCO3 177	63.7	90.2	231	199
Sulphate SO4	342	159	173	460	182
Total Metals					
Aluminum T-Al	<0.2	<0.2	<0.2	<0.2	<0.2
Antimony T-Sb	0.2	<0.2	<0.2	<0.2	<0.2
Arsenic T-As	<0.2	<0.2	<0.2	<0.2	<0.2
Barium T-Ba	0.04	0.07	0.07	0.02	0.04
Beryllium T-Be	<0.005	<0.005	<0.005	<0.005	<0.005
Bismuth T-Bi	<0.1	<0.1	<0.1	0.1	<0.1
Boron T-B	<0.1	<0.1	<0.1	<0.1	<0.1
Cadmium T-Cd	<0.01	<0.01	<0.01	<0.01	<0.01
Calcium T-Ca	107	52.2	62.8	132	90.8
Chromium T-Cr	<0.01	<0.01	<0.01	<0.01	<0.01
Cobalt T-Co	<0.01	<0.01	<0.01	<0.01	<0.01
Copper T-Cu	<0.01	<0.01	<0.01	<0.01	<0.01
Iron T-Fe	<0.03	<0.03	<0.03	<0.03	<0.03
Lead T-Pb	<0.05	<0.05	<0.05	<0.05	<0.05
Lithium T-Li	0.03	<0.01	0.02	0.05	0.02
Magnesium T-Mg	56.0	19.8	21.8	77.0	34.3
Manganese T-Mn	<0.005	<0.005	<0.005	<0.005	0.010
Molybdenum T-Mo	<0.03	<0.03	<0.03	<0.03	<0.03
Nickel T-Ni	<0.02	<0.02	<0.02	<0.02	<0.02
Phosphorus T-P	<0.3	<0.3	<0.3	<0.3	<0.3
Potassium T-K	3	<2	<2	2	<2
Selenium T-Se	<0.2	<0.2	<0.2	<0.2	<0.2
Silicon T-Si	2.32	2.80	3.04	2.04	2.99
Silver T-Ag	<0.01	<0.01	<0.01	<0.01	<0.01
Sodium T-Na	8	4	5	13	4
Strontium T-Sr	1.96	0.439	0.686	4.12	1.54
Thallium T-Tl	<0.1	<0.1	<0.1	<0.1	<0.1
Tin T-Sn	<0.03	<0.03	<0.03	<0.03	<0.03
Titanium T-Ti	<0.01	<0.01	<0.01	<0.01	<0.01
Vanadium T-V	<0.03	<0.03	<0.03	<0.03	<0.03

< = Less than the detection limit indicated.
 Results are expressed as milligrams per litre except for pH and Conductivity (umhos/cm).



RESULTS OF ANALYSIS - Water

File No. G3396

BC-WQ- STR-01- 01 96 07 23	BC-WQ- STR-02-0 1 96 07 23	BC-WQ- STR-01-0 3 96 07 23	BC-WQ-A1 -1 96 07 23	BC-WQ-A3 -1 96 07 23
-------------------------------------	-------------------------------------	-------------------------------------	----------------------------	----------------------------

Total Metals

Zinc	T-Zn	0.008	<0.005	<0.005	<0.005	0.032
------	------	-------	--------	--------	--------	-------

< = Less than the detection limit indicated.
Results are expressed as milligrams per litre except for pH and
Conductivity (umhos/cm).



METHODOLOGY

File No. G3396

Outlines of the methodologies utilized for the analysis of the samples submitted are as follows:

Conventional Parameters in Water

These analyses are carried out in accordance with procedures described in "Methods for Chemical Analysis of Water and Wastes" (USEPA), "Manual for the Chemical Analysis of Water, Wastewaters, Sediments and Biological Tissues" (BCMOE), and/or "Standard Methods for the Examination of Water and Wastewater" (APHA). Further details are available on request.













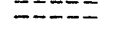
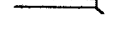

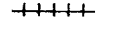
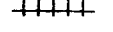
Metals in Water

This analysis is carried out in accordance with procedures described in "Standard Methods for the Examination of Water and Wastewater" 19th Edition 1995 published by the American Public Health Association, and with procedures adapted from "Test Methods for Evaluating Solid Waste" SW-846 published by the United States Environmental Protection Agency (EPA). The procedures may involve preliminary sample treatment by acid digestion or filtration (EPA Method 3005), followed by instrumental analysis by atomic absorption spectrophotometry (EPA Method 7000), inductively coupled plasma - optical emission spectrophotometry (EPA Method 6010), and/or inductively coupled plasma - mass spectrometry (EPA Method 6020).

End of Report

DRAWINGS

Legend

-  Outcrop Boundry
- W/R Waste Rock
- O/C Outcrop
- O/B Overburden
-  Adit
-  Road
-  Culvert
-  Extent Of Waste Rock
-  Trestle, with Track
-  Track
- BCWQ/A3/1 Water Quality Sample (site designation)
- BCS/1 Soil Sample (site designation)
- BCWR/P1/1 Waste Rock (site designation)
- BCB/1 Barrel Sample (site designation)
-  Slope Down
-  Secondary Mineralized Waste Rock
-  Chlorite-rich Waste Rock
-  Sericitic Waste Rock
-  Cherty Waste Rock
-  Buildings
-  Extent of Debris, Timber, Cable, Pipe, etc.
-  Fracture Location, Strike and Dip
-  Elevation in Meters
-  Photograph No. & Direction

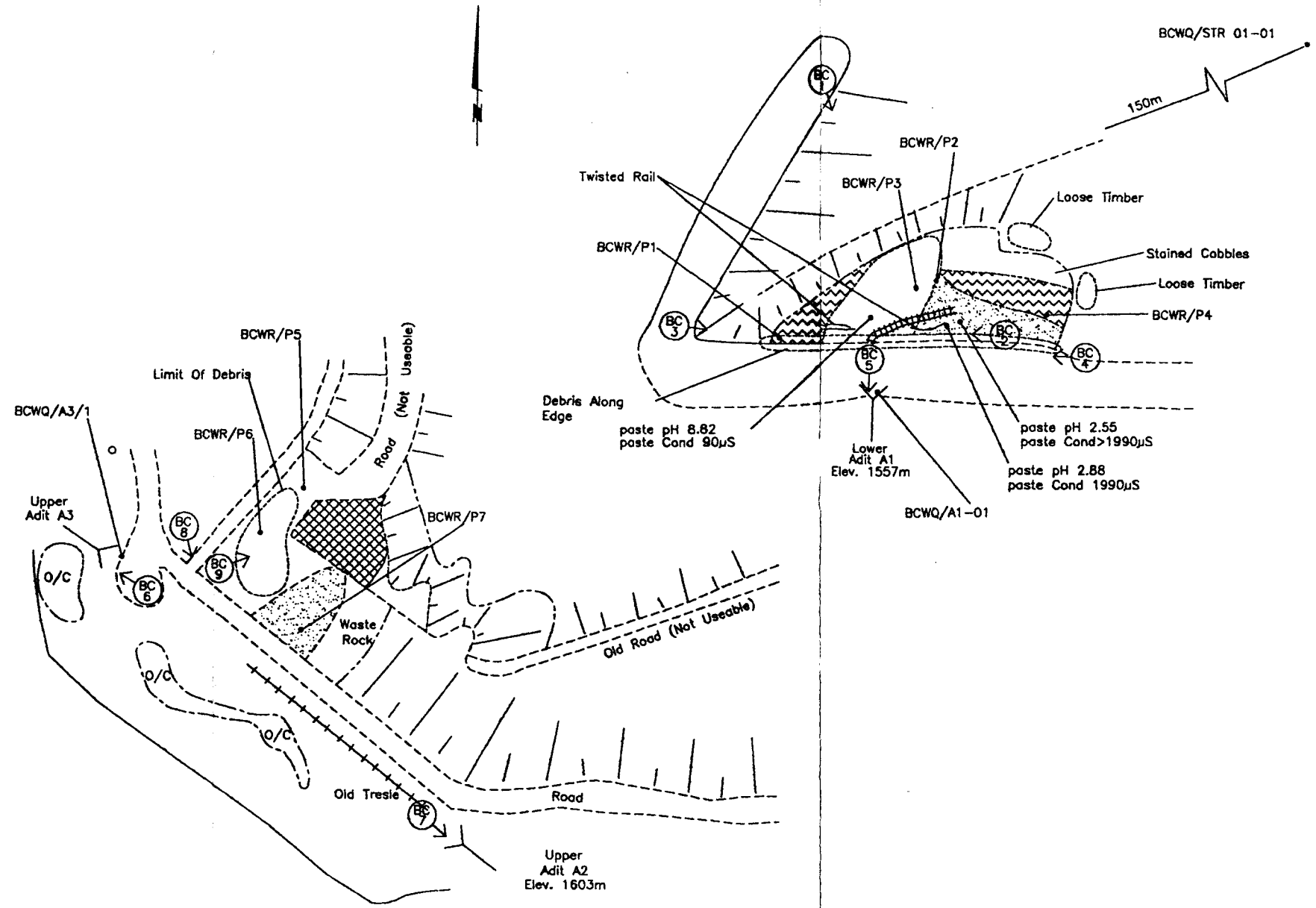

Waste Rock Sample #	paste pH Sample #	paste cond. µS/cm
BCWR/P1-1	3.40	510
BCWR/P1-2	3.62	880
BCWR/P2-1	-	-
BCWR/P2-2	-	-
BCWR/P2-3	-	-
BCWR/P3-1	-	-
BCWR/P3-2	-	-
BCWR/P4	7.41	330
BCWR/P5	8.50	70
BCWR/P6	7.61	110
BCWR/P7-1	5.88	1050
BCWR/P7-2	7.70	290

Approx. Scale: 1:1000

PLOT: 1.666666=1
CAD FILE: INVEN-96\BERKER-C\BERKER4A

 Public Works And Government Services Canada	Travaux publics et Services gouvernementaux Canada	designed by: _____
		conçu par: _____
Architectural & Engineering Services Western Region		drawn by: _____
		dessiné par: _____
Drawing title: Becker - Cochrane Mine Site Development & Geological Information Yukon Territory		approved by: _____
		approuvé par: _____
Title du dessin:		revisions: _____
project no. no. du projet:	626967	dwg. no. dessin no.: 1 of 1

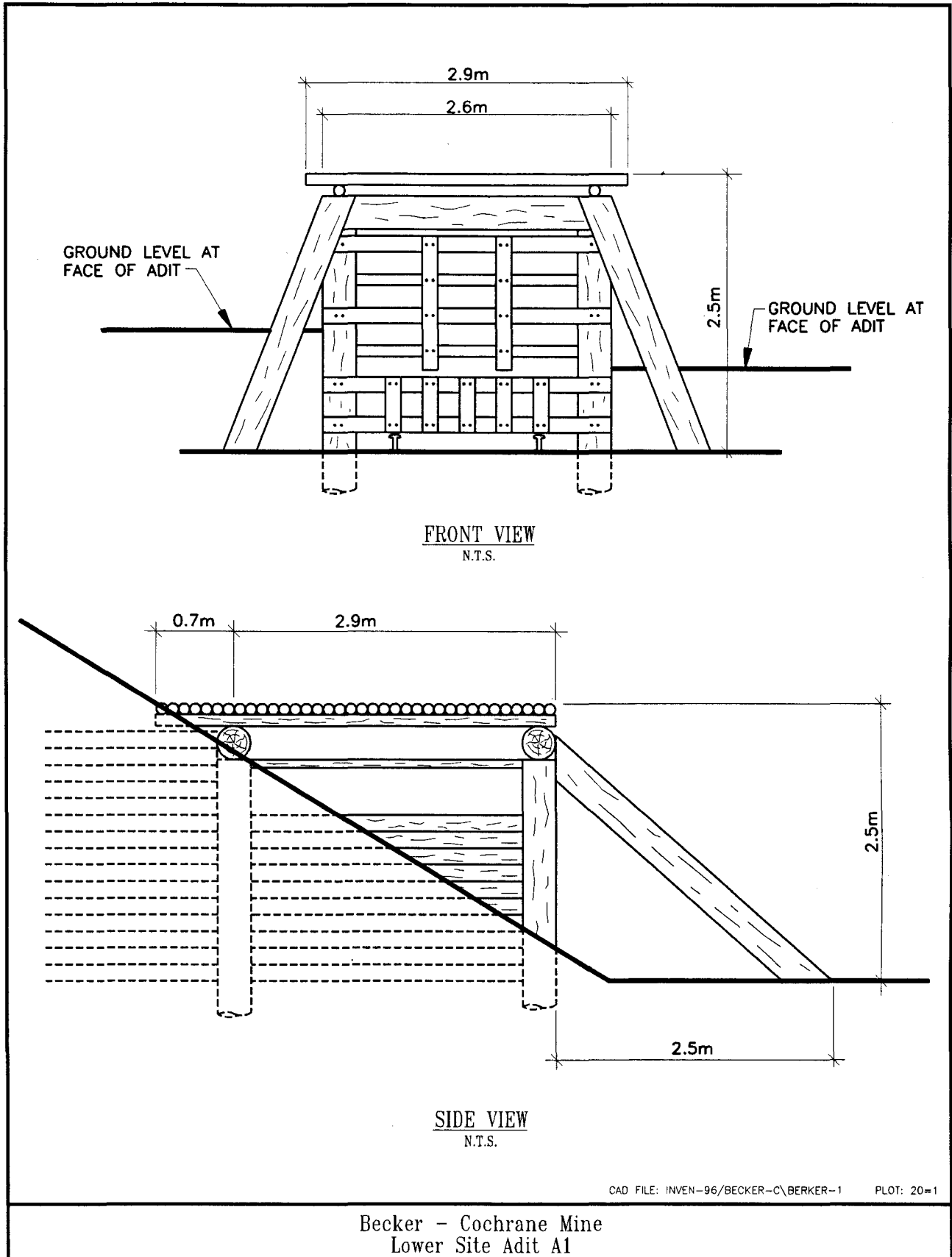

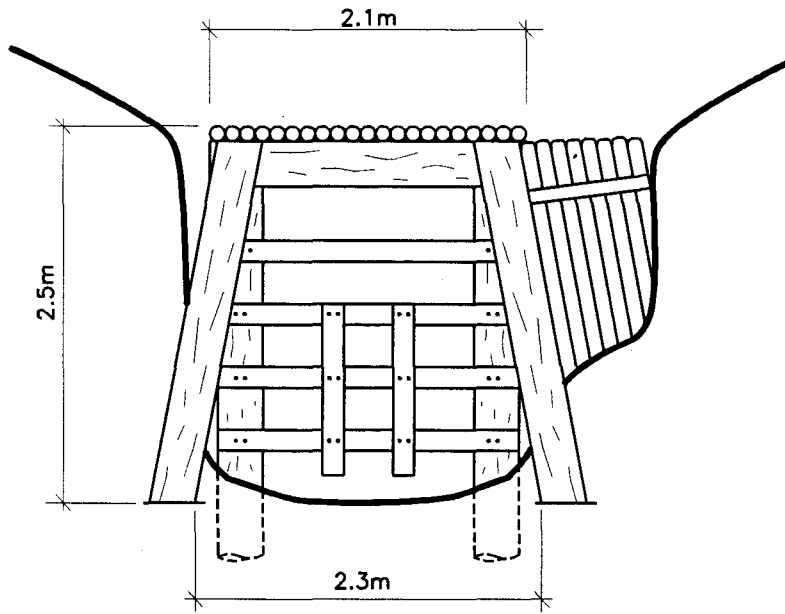

FRONT VIEW
N.T.S.

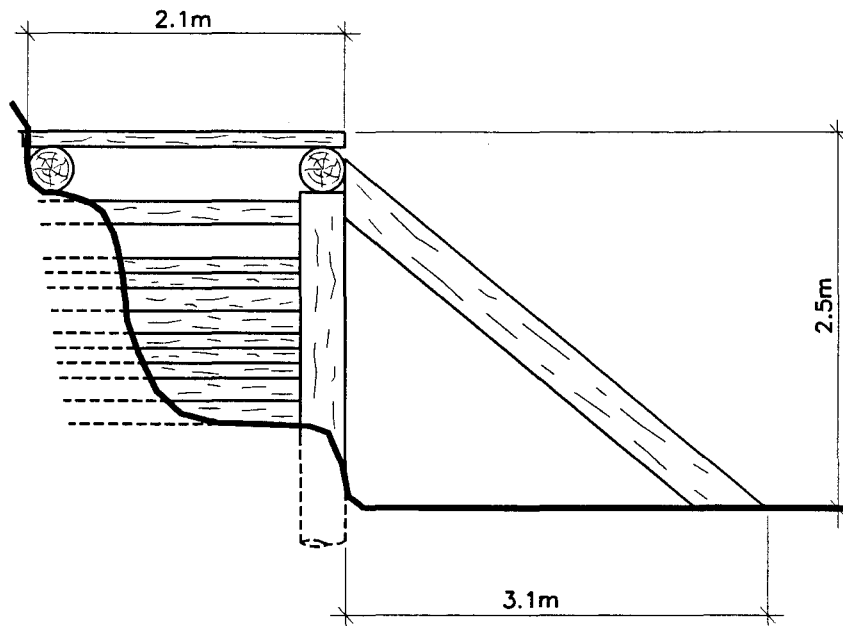

SIDE VIEW
N.T.S.

CAD FILE: INVEN-96/BECKER-C\BERKER-3 PLOT: 20=1

Becker - Cochrane Mine
Upper Site Adit A2

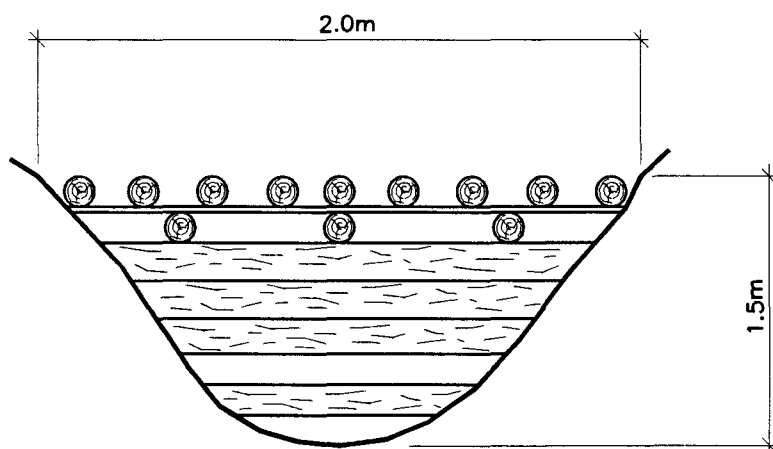

FRONT VIEW
N.T.S.

CAD FILE: INVEN-96\BECKER-C\BECKER-2 PLOT: 20=1

Becker - Cochrane Mine
Adit A3