

Canadian Geothermal Energy Association
PO Box 1462 Station M, Calgary, Alberta, T2P 2L6, Canada
info@cangea.ca - www.cangea.ca



The Yukon Geothermal Opportunities and Applications Report

March 2016

Canadian Geothermal Energy Association
PO Box 1462 Station M, Calgary, Alberta, T2P 2L6, Canada
info@cangea.ca - www.cangea.ca



Canadian Geothermal Energy Association 2016

info@cangea.ca

www.cangea.ca



Canadian Geothermal Energy Association
PO Box 1462 Station M, Calgary, Alberta, T2P 2L6, Canada
info@cangea.ca - www.cangea.ca



Disclaimer

The Canadian Geothermal Energy Association, its employees, contractors, and consultants do not make any warranty, express, or implied, or assume any legal liability or responsibility for the accuracy, completeness, or usefulness of the contents of this report.

Canadian Geothermal Energy Association
PO Box 1462 Station M, Calgary, Alberta, T2P 2L6, Canada
info@cangea.ca - www.cangea.ca



Acknowledgements

This report was written and prepared by the Canadian Geothermal Energy Association (CanGEA). It was developed with support from the Canadian Northern Economic Development Agency, Yukon Energy, and the Government of Yukon's Department of Energy, Mines, and Resources, including the Yukon Geological Survey and the Energy Solutions Center.

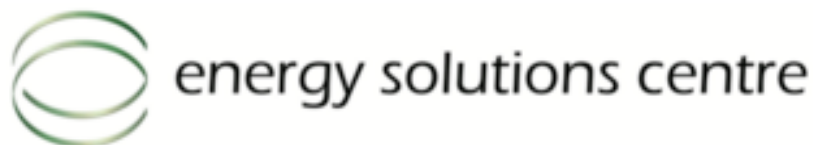

Canadian Northern Economic
Development Agency

Agence canadienne de
développement économique du Nord

Table of Contents

Disclaimer	3
Acknowledgements	4
Executive Summary	18
Introduction	21
Canadian Geothermal Energy Association	22
Opportunity Statement	22
Geothermal Power	25
Geothermal Energy Basics	26
Global Geothermal Power Industry: Worldwide Utilization	29
Types of Geothermal Power Plants	31
<i>Flash Geothermal Plants</i>	31
<i>Dry Steam Geothermal Plants</i>	32
<i>Binary Geothermal Plants</i>	32
<i>Enhanced Geothermal Systems (EGS)</i>	33
Cascaded Uses & Combined Uses	34
Direct Use of Geothermal Heat	39
Scope	40
Global Geothermal Direct Use Industry: Worldwide Utilization	41
<i>Greenhouses and Covered Ground Heating</i>	43
<i>Aquaculture</i>	45
<i>Agricultural Drying</i>	47
<i>Swimming, Bathing, & Balneology</i>	48
<i>Industrial and Process Heating Applications</i>	49
<i>Space Conditioning</i>	50
<i>Snow Melting</i>	59
Favourability Maps & Resource Base	61
How We Made The Maps	62
<i>Data Organization, Formatting, and Verification</i>	62
<i>Data Sources and Description</i>	62
<i>Base Map Data</i>	62
<i>Yukon Resource Estimate Maps</i>	69
<i>Summary Tables and Charts of Geothermal Potential</i>	79
<i>Compliance with the Global Protocol and Reporting Code</i>	79
<i>Data Limitations and Implications</i>	80
<i>Canadian National Geothermal Database</i>	81
Temperature at Depth Maps	82
Technical Potential	90
Theoretical Potential	104
Inferred vs. Indicated Resources Maps	109
Supplemental Maps	113
Yukon Community Investigation	127
Scope	128



Geothermal Survey Results.....	129
Beaver Creek	130
<i>Demographics</i>	130
<i>Geothermal Potential</i>	131
<i>Cost of Energy</i>	140
<i>Infrastructure</i>	141
<i>Economics</i>	142
<i>Industries</i>	142
Burwash Landing	144
<i>Demographics</i>	144
<i>Geothermal Potential</i>	144
<i>Cost of Energy</i>	150
<i>Infrastructure</i>	151
<i>Economics</i>	152
<i>Industries</i>	152
Carcross	155
<i>Demographics</i>	155
<i>Geothermal Potential</i>	155
<i>Cost of Energy</i>	164
<i>Infrastructure</i>	166
<i>Economics</i>	166
<i>Industries</i>	167
Carmacks.....	168
<i>Demographics</i>	168
<i>Geothermal Potential</i>	168
<i>Cost of Energy</i>	177
<i>Infrastructure</i>	178
<i>Economics</i>	179
<i>Industries</i>	179
Dawson City	184
<i>Demographics</i>	184
<i>Geothermal Potential</i>	184
<i>Cost of Energy</i>	185
<i>Infrastructure</i>	186
<i>Economics</i>	187
<i>Industries</i>	187
Destruction Bay.....	190
<i>Demographics</i>	190
<i>Geothermal Potential</i>	190
<i>Cost of Energy</i>	191
<i>Infrastructure</i>	192
<i>Economics</i>	193
<i>Industries</i>	193
Faro.....	194
<i>Demographics</i>	194
<i>Geothermal Potential</i>	194
<i>Cost of Energy</i>	204
<i>Infrastructure</i>	205



<i>Economics</i>	205
<i>Industries</i>	206
Haines Junction	207
<i>Demographics</i>	207
<i>Geothermal Potential</i>	207
<i>Cost of Energy</i>	208
<i>Infrastructure</i>	209
<i>Economics</i>	210
<i>Industries</i>	210
Mayo.....	212
<i>Demographics</i>	212
<i>Geothermal Potential</i>	212
<i>Cost of Energy</i>	213
<i>Infrastructure</i>	214
<i>Economics</i>	215
<i>Industries</i>	215
Mount Lorne	217
<i>Demographics</i>	217
<i>Geothermal Potential</i>	217
<i>Cost of Energy</i>	226
<i>Infrastructure</i>	227
<i>Economics</i>	228
<i>Industries</i>	228
Old Crow	229
<i>Demographics</i>	229
<i>Geothermal Potential</i>	229
<i>Cost of Energy</i>	231
<i>Infrastructure</i>	232
<i>Economics</i>	233
<i>Industries</i>	233
Pelly Crossing.....	234
<i>Demographics</i>	234
<i>Geothermal Potential</i>	234
<i>Cost of Energy</i>	235
<i>Infrastructure</i>	236
<i>Economics</i>	237
<i>Industries</i>	237
Ross River	239
<i>Demographics</i>	239
<i>Geothermal Potential</i>	239
<i>Cost of Energy</i>	249
<i>Infrastructure</i>	250
<i>Economics</i>	251
<i>Industries</i>	251
Tagish	254
<i>Demographics</i>	254
<i>Geothermal Potential</i>	254
<i>Cost of Energy</i>	263



<i>Infrastructure</i>	264
<i>Economics</i>	265
<i>Industries</i>	265
Teslin	266
<i>Demographics</i>	266
<i>Geothermal Potential</i>	266
<i>Cost of Energy</i>	276
<i>Infrastructure</i>	277
<i>Economics</i>	277
<i>Industries</i>	278
Watson Lake	279
<i>Demographics</i>	279
<i>Geothermal Potential</i>	279
<i>Cost of Energy</i>	290
<i>Infrastructure</i>	291
<i>Economics</i>	292
<i>Industries</i>	292
Whitehorse.....	293
<i>Demographics</i>	293
<i>Geothermal Potential</i>	293
<i>Cost of Energy</i>	302
<i>Infrastructure</i>	303
<i>Economics</i>	304
<i>Industries</i>	304
Community Comparison Table.....	305
Case Studies in Northern Communities.....	307
Introduction.....	308
Case Study: Takhini Hot Springs, Yukon	309
<i>Introduction</i>	309
<i>Past Geothermal / Energy Developments</i>	309
<i>Geothermal Potential</i>	309
<i>Economic Assessment</i>	311
<i>Possible Future Developments</i>	313
Case Study: Fort Liard, NWT	314
<i>Introduction</i>	314
<i>Demographics</i>	314
<i>Cost of Energy</i>	314
<i>Infrastructure</i>	315
<i>Past Geothermal / Energy Developments</i>	315
<i>Economic Assessment</i>	316
<i>Project Feasibility & Future Outlook</i>	318
Case Study: Chena Hot Springs, Alaska	319
<i>Introduction</i>	319
<i>Geothermal Power Plant</i>	319
<i>Other Geothermal Applications</i>	320
<i>Economic Assessment</i>	321
<i>Project Feasibility & Future Outlook</i>	323

Canadian Geothermal Energy Association
 PO Box 1462 Station M, Calgary, Alberta, T2P 2L6, Canada
 info@cangea.ca - www.cangea.ca



Case Study: Yellowknife, NWT.....	324
<i>Introduction</i>	324
<i>Past Geothermal / Energy Developments</i>	324
Geothermal Project Considerations	327
Introduction.....	328
Identification	328
Resource Rights & Legislation	329
Local Market	331
Uncertainty	332
Resource Exploration and Characterization.....	333
Conceptual Project Design.....	334
Environmental Impact of Power Plants.....	334
Finances and Funding.....	336
Public Acceptance	337
Endnotes	339

List of Figures

<i>Figure 1: An example of cascading for combined heat and power</i>	34
<i>Figure 2: Schematic of combined geothermal heat and power utilization at Neustadt Glewe, Germany</i>	36
<i>Figure 3: Geothermal direct use applications worldwide in 2010, distributed by percentage of total installed capacity (MWt)</i>	42
<i>Figure 4: Geothermal direct use applications worldwide in 2010, distributed by percentage of total energy usage (TJ/yr)</i>	43
<i>Figure 5: Optimum temperature for growing various vegetables</i>	44
<i>Figure 6: Growth rate of aquatic species compared to land animals</i>	46
<i>Figure 7: Continuous belt dehydration plant, schematic</i>	48
<i>Figure 8: Klamath Falls milk pasteurization flow diagram</i>	50
<i>Figure 9: Oregon Institute of Technology heating and cooling system</i>	51
<i>Figure 10: An example of a residential down hole heat exchanger installation</i>	53
<i>Figure 11: Down hole heat exchanger system at Ponderosa Middle School, Klamath Falls, Oregon</i>	54
<i>Figure 12: Geothermal direct-utilization system using a heat exchanger</i>	55
<i>Figure 13: Meeting peak demand with fossil fuel</i>	55
<i>Figure 14: Reykjavik, Iceland district heating system</i>	56
<i>Figure 15: Example of a Melun I-Almont (Paris) doublet heating system</i>	57
<i>Figure 16: Typical ground-source and groundwater geothermal heat pump installations</i>	58
<i>Figure 17: Bottom hole temperatures, Yukon</i>	65
<i>Figure 18: Series of images illustrating how datasets were used in combination to estimate the thickness of the sedimentary cover</i>	68
<i>Figure 19: Temperature vs. depth profile of selected boreholes</i>	72
<i>Figure 20: Primary geothermal exploration areas</i>	77
<i>Figure 21: Average annual surface temperature</i>	84
<i>Figure 22: Average temperature within wells – 500m – 1,000m</i>	85
<i>Figure 23: Average temperature within wells – 1,000m – 2,000m</i>	86
<i>Figure 24: Average temperature within wells – 2,000m – 3,000m</i>	87
<i>Figure 25: Average temperature within wells – 3,000m – 4,000m</i>	88
<i>Figure 26: Average temperature within wells – 4,000m – 5,000m</i>	89
<i>Figure 27: Indicated vs. inferred resources (5% recovery)</i>	90
<i>Figure 28: Technical potential, NTS grid version</i>	91
<i>Figure 29: Technical potential between 1,000m and 2,000m at 5% recoverability</i>	92
<i>Figure 30: Technical potential between 2,000m and 3,000m at 5% recoverability</i>	93
<i>Figure 31: Technical potential between 3,000m and 4,000m at 5% recoverability</i>	94

Figure 32: Technical potential between 4,000m and 5,000m at 5% recoverability..... 95

Figure 33: Technical potential between 1,000m and 2,000m at 14% recoverability..... 96

Figure 34: Technical potential between 2,000m and 3,000m at 14% recoverability..... 97

Figure 35: Technical potential between 3,000m and 4,000m at 14% recoverability..... 98

Figure 36: Technical potential between 4,000m and 5,000m at 14% recoverability..... 99

Figure 37: Technical potential between 1,000m and 2,000m at 20% recoverability..... 100

Figure 38: Technical potential between 2,000m and 3,000m at 20% recoverability..... 101

Figure 39: Technical potential between 3,000m and 4,000m at 20% recoverability..... 102

Figure 40: Technical potential between 4,000m and 5,000m at 20% recoverability..... 103

Figure 41: Theoretical generation potential by depth – Indicated vs. Inferred Resources..... 104

Figure 42: Theoretical generation potential by depth – Indicated vs. Inferred Resources - detailed..... 104

Figure 43: Theoretical potential between 1,000m and 2,000m..... 105

Figure 44: Theoretical potential between 2,000m and 3,000m..... 106

Figure 45: Theoretical potential between 3,000m and 4,000m..... 107

Figure 46: Theoretical potential between 4,000m and 5,000m..... 108

Figure 47: Map of indicated vs. inferred resources – 1,500m 109

Figure 48: Map of indicated vs. inferred resources – 2,500m 110

Figure 49: Map of indicated vs. inferred resources – 3,500m 111

Figure 50: Map of indicated vs. inferred resources – 4,500m 112

Figure 51: Average geothermal gradient – 1,000m – 2,000m..... 113

Figure 52: Average geothermal gradient – 2,000m – 3,000m..... 114

Figure 53: Average geothermal gradient – 3,000m – 4,000m..... 115

Figure 54: Average geothermal gradient – 4,000m – 5,000m..... 116

Figure 55: Depth to basement..... 117

Figure 56: Average estimated conductivity – 1,000m – 2,000m 118

Figure 57: Average estimated conductivity – 2,000m – 3,000m 119

Figure 58: Average estimated conductivity – 3,000m – 4,000m 120

Figure 59: Average estimated conductivity – 4,000m – 5,000m 121

Figure 60: Average estimated heat generation – 1,000m – 2,000m..... 122

Figure 61: Average estimated heat generation – 2,000m – 3,000m..... 123

Figure 62: Average estimated heat generation – 3,000m – 4,000m..... 124

Figure 63: Average estimated heat generation – 4,000m – 5,000m..... 125

Figure 64: Estimated heat flow at surface 126

List of Tables

<i>Table 1: Geothermal power production in 2013.....</i>	29
<i>Table 2: Installed electric capacities 2005-2013 (MW_e).....</i>	30
<i>Table 3: Geothermal electricity produced 2005-2013 (GWh/a)</i>	30
<i>Table 4: Geothermal power production in 2013.....</i>	41
<i>Table 5: Summary of the various categories of direct-use worldwide in 2015.....</i>	42
<i>Table 6: Technical potential, NTS grid version</i>	64
<i>Table 7: Beaver Creek 2011 demographics</i>	130
<i>Table 8: Temperature at depth & technical geothermal potential in Beaver Creek.....</i>	131
<i>Table 9: Cost table for an exemplary 1 MW_e/13 MW_t CHP project in northern Canada (Wet Fractured Rock environment).....</i>	131
<i>Table 10: Estimated possible vegetable production for 1,440 sqft of growing space (monoculture).....</i>	133
<i>Table 11: Exemplary greenhouse design – Beaver Creek</i>	134
<i>Table 12: Exemplary greenhouse design – surface areas - Beaver Creek.....</i>	135
<i>Table 13: Exemplary greenhouse design – material cost - Beaver Creek.....</i>	135
<i>Table 14: Residential energy prices in Beaver Creek.....</i>	140
<i>Table 15: General service energy prices in Beaver Creek</i>	140
<i>Table 16: Beaver Creek 2015 residential fuel prices.....</i>	141
<i>Table 17: Beaver Creek infrastructure profile.....</i>	141
<i>Table 18: Beaver Creek 2015 Spatial Price Index (Whitehorse = 100).....</i>	142
<i>Table 19: Burwash Landing 2011 demographics</i>	144
<i>Table 20: Temperature at depth & technical geothermal potential in Burwash Landing</i>	144
<i>Table 21: Estimated possible vegetable production for 1,320 sqft of growing space (monoculture).....</i>	146
<i>Table 22: Exemplary greenhouse design – Burwash Landing.....</i>	147
<i>Table 23: Exemplary greenhouse design – surface areas – Burwash Landing</i>	147
<i>Table 24: Exemplary greenhouse design – material cost – Burwash Landing.....</i>	148
<i>Table 25: Residential energy prices in Burwash Landing</i>	150
<i>Table 26: General service energy prices in Burwash Landing.....</i>	150
<i>Table 27: Burwash Landing 2015 residential fuel prices</i>	151
<i>Table 28: Burwash Landing infrastructure profile</i>	151
<i>Table 29: Burwash Landing 2015 Spatial Price Index (Whitehorse = 100)</i>	152
<i>Table 30: Wellgreen mine based on preliminary economic assessment – February 2015</i>	154
<i>Table 31: Carcross 2011 demographics</i>	155
<i>Table 32: Temperature at depth & technical geothermal potential in Carcross</i>	155

<i>Table 33: Cost table for an exemplary 1 MW_e/13 MW_t CHP project in northern Canada (HSA environment).....</i>	<i>156</i>
<i>Table 34: Estimated vegetable production for 1,440 sqft of growing space - Carcross.....</i>	<i>158</i>
<i>Table 35: Exemplary greenhouse design – Carcross.....</i>	<i>159</i>
<i>Table 36: Exemplary greenhouse design – surface areas - Carcross.....</i>	<i>159</i>
<i>Table 37: Exemplary greenhouse design – material cost - Carcross.....</i>	<i>160</i>
<i>Table 38: Residential energy prices in Carcross.....</i>	<i>164</i>
<i>Table 39: General service energy prices in Carcross.....</i>	<i>165</i>
<i>Table 40: Carcross 2015 residential fuel prices.....</i>	<i>165</i>
<i>Table 41: Carcross infrastructure profile.....</i>	<i>166</i>
<i>Table 42: Carcross 2015 Spatial Price Index (Whitehorse = 100).....</i>	<i>166</i>
<i>Table 43: Carmacks 2011 demographics.....</i>	<i>168</i>
<i>Table 44: Temperature at depth & technical geothermal potential in Carmacks.....</i>	<i>168</i>
<i>Table 45: Cost table for an exemplary 1 MW_e/13 MW_t CHP project in northern Canada (HSA environment).....</i>	<i>169</i>
<i>Table 46: Estimated vegetable production for 1,860 sqft of growing space - Carmacks.....</i>	<i>172</i>
<i>Table 47: Exemplary greenhouse design – Carmacks.....</i>	<i>173</i>
<i>Table 48: Exemplary greenhouse design – surface areas - Carmacks.....</i>	<i>173</i>
<i>Table 49: Exemplary greenhouse design – material cost - Carmacks.....</i>	<i>173</i>
<i>Table 50: Residential energy prices in Carmacks.....</i>	<i>177</i>
<i>Table 51: General service energy prices in Carmacks.....</i>	<i>177</i>
<i>Table 52: Carmacks 2015 residential fuel prices.....</i>	<i>178</i>
<i>Table 53: Carmacks infrastructure profile.....</i>	<i>178</i>
<i>Table 54: Carmacks 2015 Spatial Price Index (Whitehorse = 100).....</i>	<i>179</i>
<i>Table 55: Carmacks copper mine based on preliminary economic assessment – June 2014.....</i>	<i>180</i>
<i>Table 56: Casino mine based on project proposal – Jan 2014.....</i>	<i>181</i>
<i>Table 57: Coffee mine based on preliminary economic assessment – June 2014.....</i>	<i>182</i>
<i>Table 58: Klaza mine based on technical report – June 2015.....</i>	<i>183</i>
<i>Table 59: Dawson 2011 demographics.....</i>	<i>184</i>
<i>Table 60: Temperature at depth & technical geothermal potential in Dawson.....</i>	<i>184</i>
<i>Table 61: Residential energy prices in Dawson.....</i>	<i>185</i>
<i>Table 62: General service energy prices in Dawson.....</i>	<i>185</i>
<i>Table 63: Dawson 2015 residential fuel prices.....</i>	<i>186</i>
<i>Table 64: Dawson infrastructure profile.....</i>	<i>186</i>
<i>Table 65: Dawson 2015 Spatial Price Index (Whitehorse = 100).....</i>	<i>187</i>



<i>Table 66: Brewery Creek mine based on preliminary economic assessment – January 2015.....</i>	<i>189</i>
<i>Table 67: Destruction Bay Landing 2011 demographics.....</i>	<i>190</i>
<i>Table 68: Temperature at depth & technical geothermal potential in Destruction Bay.....</i>	<i>190</i>
<i>Table 69: Residential energy prices in Destruction Bay.....</i>	<i>191</i>
<i>Table 70: General service energy prices in Destruction Bay.....</i>	<i>191</i>
<i>Table 71: Destruction Bay 2015 residential fuel prices.....</i>	<i>192</i>
<i>Table 72: Destruction Bay infrastructure profile.....</i>	<i>192</i>
<i>Table 73: Destruction Bay 2015 Spatial Price Index (Whitehorse = 100).....</i>	<i>193</i>
<i>Table 74: Faro 2011 demographics.....</i>	<i>194</i>
<i>Table 75: Temperature at depth & technical geothermal potential in Faro.....</i>	<i>194</i>
<i>Table 76: Cost table for an exemplary 1 MW_e/13 MW_t CHP project in northern Canada (Wet Fractured Rock environment).....</i>	<i>195</i>
<i>Table 77: Estimated vegetable production for 6,000 sqft of growing space - Faro.....</i>	<i>198</i>
<i>Table 78: Exemplary greenhouse design – Faro.....</i>	<i>199</i>
<i>Table 79: Exemplary greenhouse design – surface areas - Faro.....</i>	<i>199</i>
<i>Table 80: Exemplary greenhouse design – material cost - Faro.....</i>	<i>199</i>
<i>Table 81: Residential energy prices in Faro.....</i>	<i>204</i>
<i>Table 82: General service energy prices in Faro.....</i>	<i>204</i>
<i>Table 83: Faro 2015 residential fuel prices.....</i>	<i>204</i>
<i>Table 84: Faro infrastructure profile.....</i>	<i>205</i>
<i>Table 85: Faro 2015 Spatial Price Index (Whitehorse = 100).....</i>	<i>205</i>
<i>Table 86: Haines Junction 2011 demographics.....</i>	<i>207</i>
<i>Table 87: Temperature at depth & technical geothermal potential in Haines Junction.....</i>	<i>207</i>
<i>Table 88: Residential energy prices in Haines Junction.....</i>	<i>208</i>
<i>Table 89: General service energy prices in Haines Junction.....</i>	<i>208</i>
<i>Table 90: Haines Junction 2015 residential fuel prices.....</i>	<i>209</i>
<i>Table 91: Haines Junction infrastructure profile.....</i>	<i>209</i>
<i>Table 92: Haines Junction 2011* Spatial Price Index (Whitehorse = 100).....</i>	<i>210</i>
<i>Table 93: Mayo 2011 demographics.....</i>	<i>212</i>
<i>Table 94: Temperature at depth & technical geothermal potential in Mayo.....</i>	<i>212</i>
<i>Table 95: Residential energy prices in Mayo.....</i>	<i>213</i>
<i>Table 96: General service energy prices in Mayo.....</i>	<i>213</i>
<i>Table 97: Mayo 2015 residential fuel prices.....</i>	<i>214</i>
<i>Table 98: Mayo infrastructure profile.....</i>	<i>214</i>
<i>Table 99: Mayo 2015 Spatial Price Index (Whitehorse = 100).....</i>	<i>215</i>



<i>Table 100: Dublin Gulch mine based on preliminary economic assessment – June 2014</i>	<i>216</i>
<i>Table 101: Mount Lorne 2011 demographics.....</i>	<i>217</i>
<i>Table 102: Temperature at depth & technical geothermal potential in Mount Lorne.....</i>	<i>217</i>
<i>Table 103: Cost table for an exemplary 1 MW_e/13 MW_t CHP project in northern Canada (Wet Fractured Rock environment).....</i>	<i>218</i>
<i>Table 104: Estimated vegetable production for 1,500 sqft of growing space – Mt. Lorne.....</i>	<i>220</i>
<i>Table 105: Exemplary greenhouse design – Mt. Lorne.....</i>	<i>221</i>
<i>Table 106: Exemplary greenhouse design – surface areas - Mt. Lorne.....</i>	<i>221</i>
<i>Table 107: Exemplary greenhouse design – material cost - Mt. Lorne.....</i>	<i>222</i>
<i>Table 108: Residential energy prices in Mount Lorne.....</i>	<i>226</i>
<i>Table 109: General service energy prices in Mount Lorne</i>	<i>226</i>
<i>Table 110: Mount Lorne 2015 residential fuel prices.....</i>	<i>227</i>
<i>Table 111: Mount Lorne infrastructure profile.....</i>	<i>227</i>
<i>Table 112: Mount Lorne 2015 Spatial Price Index (Whitehorse = 100).....</i>	<i>228</i>
<i>Table 113: Old Crow 2011 demographics.....</i>	<i>229</i>
<i>Table 114: Temperature at depth & technical geothermal potential in Old Crow.....</i>	<i>229</i>
<i>Table 115: Residential energy prices in Old Crow.....</i>	<i>231</i>
<i>Table 116: General service energy prices in Old Crow.....</i>	<i>231</i>
<i>Table 117: Old Crow 2015 residential fuel prices</i>	<i>231</i>
<i>Table 118: Old Crow infrastructure profile.....</i>	<i>232</i>
<i>Table 119: Old Crow 2015 Spatial Price Index (Whitehorse = 100)</i>	<i>233</i>
<i>Table 120: Pelly Crossing 2011 demographics.....</i>	<i>234</i>
<i>Table 121: Temperature at depth & technical geothermal potential in Pelly Crossing.....</i>	<i>234</i>
<i>Table 122: Residential energy prices in Pelly Crossing.....</i>	<i>235</i>
<i>Table 123: General service energy prices in Pelly Crossing</i>	<i>235</i>
<i>Table 124: Pelly Crossing 2015 residential fuel prices.....</i>	<i>236</i>
<i>Table 125: Pelly Crossing infrastructure profile.....</i>	<i>236</i>
<i>Table 126: Pelly Crossing 2015 Spatial Price Index (Whitehorse = 100)</i>	<i>237</i>
<i>Table 127: Minto Mine 2014 Key Operational Facts.....</i>	<i>238</i>
<i>Table 128: Ross River 2011 demographics</i>	<i>239</i>
<i>Table 129: Temperature at depth & technical geothermal potential in Ross River</i>	<i>239</i>
<i>Table 130: Cost table for an exemplary 1 MW_e/13 MW_t CHP project in northern Canada (Wet Fractured Rock environment).....</i>	<i>240</i>
<i>Table 131: Estimated vegetable production for 1,800 sqft of growing space – Ross River.....</i>	<i>243</i>
<i>Table 132: Exemplary greenhouse design – Ross River.....</i>	<i>243</i>

<i>Table 133: Exemplary greenhouse design – surface areas - Ross River</i>	244
<i>Table 134: Exemplary greenhouse design – material cost - Ross River</i>	244
<i>Table 135: Residential energy prices in Ross River</i>	249
<i>Table 136: General service energy prices in Ross River</i>	249
<i>Table 137: Ross River 2015 residential fuel prices</i>	249
<i>Table 138: Ross River infrastructure profile</i>	250
<i>Table 139: Ross River 2015 Spatial Price Index (Whitehorse = 100)</i>	251
<i>Table 140: Mactung mine based on technical report</i>	251
<i>Table 141: Wolverine mine– June 2014</i>	252
<i>Table 142: Selwyn mine data</i>	252
<i>Table 143: Tagish 2011 demographics</i>	254
<i>Table 144: Geothermal potential in Tagish</i>	254
<i>Table 145: Temperature at depth & technical geothermal potential in Tagish</i>	255
<i>Table 146: Cost table for an exemplary 1 MW_e/13 MW_t CHP project in northern Canada (HSA environment)</i>	255
<i>Table 147: Estimated vegetable production for 2,400 sqft of growing space - Tagish</i>	257
<i>Table 148: Exemplary greenhouse design – Tagish</i>	258
<i>Table 149: Exemplary greenhouse design – surface areas - Tagish</i>	258
<i>Table 150: Exemplary greenhouse design – material cost - Tagish</i>	259
<i>Table 151: Residential energy prices in Tagish</i>	263
<i>Table 152: General service energy prices in Tagish</i>	263
<i>Table 153: Tagish 2015 residential fuel prices</i>	264
<i>Table 154: Tagish infrastructure profile</i>	264
<i>Table 155: Tagish 2015 Spatial Price Index (Whitehorse = 100)</i>	265
<i>Table 156: Teslin 2011 demographics</i>	266
<i>Table 157: Temperature at depth & technical geothermal potential in Teslin</i>	266
<i>Table 158: Cost table for an exemplary 1 MW_e/13 MW_t CHP project in northern Canada (HSA environment)</i>	267
<i>Table 159: Estimated vegetable production for 1,740 sqft of growing space - Teslin</i>	269
<i>Table 160: Exemplary greenhouse design – Teslin</i>	270
<i>Table 161: Exemplary greenhouse design – surface areas - Teslin</i>	270
<i>Table 162: Exemplary greenhouse design – material cost - Teslin</i>	271
<i>Table 163: Residential energy prices in Teslin</i>	276
<i>Table 164: General service energy prices in Teslin</i>	276
<i>Table 165: Teslin 2015 residential fuel prices</i>	276



<i>Table 166: Teslin infrastructure profile</i>	<i>277</i>
<i>Table 167: Teslin 2015 Spatial Price Index (Whitehorse = 100).....</i>	<i>277</i>
<i>Table 168: Watson Lake 2011 demographics.....</i>	<i>279</i>
<i>Table 169: Temperature at depth & technical geothermal potential in Watson Lake.....</i>	<i>279</i>
<i>Table 170: Cost table for an exemplary 1 MW_e/13 MW_t CHP project in northern Canada (Wet Fractured Rock environment).....</i>	<i>280</i>
<i>Table 171: Estimated vegetable production for 2,940 sqft of growing space – Watson Lake</i>	<i>282</i>
<i>Table 172: Exemplary greenhouse design – Watson Lake.....</i>	<i>283</i>
<i>Table 173: Exemplary greenhouse design – surface areas - Watson Lake</i>	<i>283</i>
<i>Table 174: Exemplary greenhouse design – material cost - Watson Lake.....</i>	<i>284</i>
<i>Table 175: Residential energy prices in Watson Lake.....</i>	<i>290</i>
<i>Table 176: General service energy prices in Watson Lake.....</i>	<i>290</i>
<i>Table 177: Watson Lake 2015 residential fuel prices</i>	<i>291</i>
<i>Table 178: Watson Lake infrastructure profile</i>	<i>291</i>
<i>Table 179: Watson Lake 2015 Spatial Price Index (Whitehorse = 100).....</i>	<i>292</i>
<i>Table 180: Whitehorse 2011 demographics.....</i>	<i>293</i>
<i>Table 181: Temperature at depth & technical geothermal potential in Whitehorse.....</i>	<i>294</i>
<i>Table 182: Cost table for an exemplary 5MW_e/66MW_t CHP project in northern Canada (HSA environment).....</i>	<i>295</i>
<i>Table 183: Estimated vegetable production for 7,320 sqft of growing space - Whitehorse</i>	<i>297</i>
<i>Table 184: Exemplary greenhouse design – Whitehorse.....</i>	<i>298</i>
<i>Table 185: Exemplary greenhouse design – surface areas - Whitehorse.....</i>	<i>298</i>
<i>Table 186: Exemplary greenhouse design – material cost - Whitehorse.....</i>	<i>299</i>
<i>Table 187: Residential energy prices in Whitehorse.....</i>	<i>302</i>
<i>Table 188: General service energy prices in Whitehorse.....</i>	<i>302</i>
<i>Table 189: Whitehorse 2015 residential fuel prices.....</i>	<i>303</i>
<i>Table 190: Whitehorse infrastructure profile.....</i>	<i>303</i>
<i>Table 191: Whitehorse 2015 Spatial Price Index (Whitehorse = 100)</i>	<i>304</i>
<i>Table 192: Chemical components of the geothermal surface water at Takhini Hot Springs</i>	<i>309</i>
<i>Table 193: Fort Liard demographics.....</i>	<i>314</i>
<i>Table 194: General service energy prices in Fort Liard.....</i>	<i>314</i>
<i>Table 195: Fort Liard infrastructure profile</i>	<i>315</i>

Executive Summary

In partnership with the Canadian Northern Economic Development Agency, the Government of Yukon's Department of Energy, Mines and Resources' Energy Branch (the Energy Solutions Centre), Yukon Energy and the Yukon Geological Survey, CanGEA developed this report with the primary goal of exploring the possibilities to use geothermal energy for electricity generation and heat applications in the Yukon.

Providing background knowledge to the reader, the report starts with an introduction to geothermal energy and its possible applications. It details the different possibilities of power production from geothermal resources and identifies the most important direct use applications.

The second part of the report introduces the geothermal favourability maps of the Yukon. It provides qualitative and quantitative information about local temperature profiles, the geothermal gradient, estimated conductivity, estimated heat flow and the technical and theoretical potential. The favourability maps were also released separately and are available as part of the Canadian National Geothermal Database (CNGD). The geothermal potential of the Yukon implies more than 1,700 MW of indicated resources at a depth of less than 5,000 metres (using a 5% recovery factor). This number rises to approximately 5,000 MW when inferred resources are considered. Approximately 100 MW of low-hanging-fruit resources are available at a depth of less than 2,000 metres. Large areas of the Yukon were not available for incorporation into this study due to the lack of sufficient data across much of the territory. While the reported resource estimates are substantial, the estimates are dominantly based on potential resources in the north-eastern half and southeastern tip of the Yukon only, due to the data density from the oil and gas wells drilled in the Peel Plateau, Mackenzie Delta, and the Liard Basin. The overall result of these limitations is a potential underestimation of the geothermal resource potential in the Yukon.

The third part of the report takes the information to the community level and provides detailed information about 17 Yukon communities and their demographics, infrastructure

Canadian Geothermal Energy Association
PO Box 1462 Station M, Calgary, Alberta, T2P 2L6, Canada
info@cangea.ca - www.cangea.ca



and geothermal potential. Suitable geothermal direct use applications are discussed in detail and valuable information for community leaders and decision makers is shared.

After the discussion of specific communities, four case studies from Alaska, the Yukon and the Northwest Territories are portrayed in order to display the variability of geothermal projects in northern climates and their development.

Ending with information on resource identification, resource rights, market factors, uncertainty, resource exploration, environmental impact, finances and public acceptance, the report explains why these factors are essential to geothermal project development.

This report describes how geothermal energy has the potential to create valuable opportunities for the population of the Yukon and can help to reduce high electricity and heating costs, which are prevalent in remote communities in the Canadian North. Geothermal energy can help fostering energy security, economic growth and sustainable development in one of Canada's most pristine environments.

Introduction

Yukon Geothermal Energy Report
2016

Canadian Geothermal Energy Association
PO Box 1462 Station M, Calgary, Alberta, T2P 2L6, Canada
info@cangea.ca - www.cangea.ca



Canadian Geothermal Energy Association

The Canadian Geothermal Energy Association (CanGEO) is the collective voice of Canada's geothermal energy industry. As a non-profit industry association, CanGEO represents the interests of its member companies with the primary goal of unlocking the country's tremendous geothermal energy potential.

The Canadian Geothermal Energy Association (CanGEO) was founded and incorporated in 2007 and earned the right to continue its mandate in 2014 under the new Canadian Not for Profit Corporations Act. CanGEO is distinct from previous geothermal industry efforts in the 1980's-mid 2000's in that CanGEO's main activity is political advocacy with a truly pan-Canada effort on the direct use of geothermal heat and power production. CanGEO complements the activities of the Canadian Geo-Exchange Coalition (CGC), which represents the ground source heat pump industry, and the Canadian Geothermal Research Council (CanGRC), which serves the academic and research community.

CanGEO promotes the industry and the potential of geothermal energy in Canada through outreach events, research, policy work and representation of Canadian interests internationally. CanGEO's mission is to "accelerate Canadian exploration and development of geothermal resources in order to provide secure clean and sustainable energy".

Opportunity Statement

We have barely scratched the surface when it comes to the exploration and utilization of geothermal energy in Canada. Significant time and resources have been put into research; however, Canada has yet to really utilize geothermal beyond select hot springs and spas. Interest in this technology peaked in the 1980's, when rising fossil fuel prices sparked interest in sustainable energy solutions out of economic considerations. However all exploratory work was abandoned by the federal government once energy prices stabilized on a reasonable level. Internationally, interest and research in geothermal energy did not slow down in development, with 24 countries having a

Canadian Geothermal Energy Association
PO Box 1462 Station M, Calgary, Alberta, T2P 2L6, Canada
info@cangea.ca - www.cangea.ca



capacity of approximately 13,300 MWe of installed geothermal operating capacity in 2016¹.

The Yukon has significant potential for geothermal electricity generation, direct use of heat, and some of the highest temperature/enthalpy resources in the country. Hot sedimentary aquifers are located in the foreland basins of eastern Yukon and the Canadian Cordillera passes through the territory, offering potential for high temperature geothermal project development. The geothermal potential of the Yukon implies more than 1,700 MW of indicated resources at a depth of less than 5,000 metres (using a 5% recovery factor). This number rises to approximately 5,000 MW when inferred resources are considered. Approximately 100 MW of low-hanging-fruit resources are available at a depth of less than 2,000 metres. Large areas of the Yukon were not available for incorporation into this study due to the lack of sufficient data across much of the territory. While the reported resource estimates are substantial, the Global Protocol estimates are dominantly based on potential resources in the north-eastern half and south-eastern tip of the Yukon only, due to the data density from the oil and gas wells drilled in the Peel Plateau, Mackenzie Delta, and the Liard Basin.

The Global Protocol is not suitable for incorporating data within volcanic and crystalline rock terrain. Therefore, areas that are indicative of high potential for geothermal development, based on geological setting and previous evaluations, are not adequately reflected within the mapping study. Further evaluation of the oil and gas industry data would likely serve to increase the confidence in the resource estimates for the Yukon. Significant water production data exists within the industry. This could be combined with relevant thermal data to produce a "Measured" estimate of the geothermal potential of specific reservoirs, according to the Canada Geothermal Code for Public Reporting. There may be other industry information that would serve to increase the data coverage and add to the estimates for geothermal potential in the Yukon if it were made available or collected during future work, such as within the mineral exploration or water well drilling industries. The overall result of these limitations is a significant underestimation of the geothermal resource potential in the Yukon, in CanGEO's opinion.

Canadian Geothermal Energy Association
PO Box 1462 Station M, Calgary, Alberta, T2P 2L6, Canada
info@cangea.ca - www.cangea.ca



For many communities the high cost of importing diesel poses as a barrier to economic diversity, which in turn results in high costs of food and other goods. The implementation of geothermal energy projects, particularly in off-grid communities, could provide a significant contribution towards lowering fuel prices, improving food security and enhancing the quality of life in the Yukon. Additionally, the development of Canada's northern geothermal resources would foster economic growth and sustainable development in one of the most fragile environments of Canada.

Geothermal Power

Yukon Geothermal Energy Report
2016

Geothermal Energy Basics

Geothermal energy can be harnessed by exploiting the thermal energy, which is stored in the earth's crust.² Since conductive and convective heat transfer is ubiquitous in the earth's mantle, thermal energy is distributed all around the globe.³ Nevertheless, the distribution pattern is not uniform and geothermal gradients differ according to geological settings.⁴ The geothermal gradient is measured as an increase of temperature per unit of depth.

The average temperature gradient ranges from 25 °C to 30 °C per kilometre, which mainly results from the decay of potassium, uranium and thorium isotopes. However, the gradient can be influenced locally by intrusions of molten rock.⁵ The gradient is generally the steepest at tectonic plate boundaries, where temperature usually rises quickly while gaining depth.⁶ People who inhabited these areas were historically among the first to explore the use of geothermal energy. Proof of early use of geothermal energy is present in areas where geothermal fluid reaches the surface of the earth and creates hot springs.⁷ This manifestation of geothermal energy was used for bathing and washing clothes for more than 7,000 years, while industrial use of geothermal energy, either directly or for power production, didn't begin until the early twentieth century. One of the first industrially used geothermal reservoirs was Lardarello in Italy, where electricity was produced from the underlying geothermal resource in 1902.⁸

Industrial use requires accessibility of the resource. Accessibility can be achieved at any location through drilling to a certain depth until the desired temperature is reached. Drilling costs are important factors in geothermal development and therefore economic accessibility is a requirement as well. Development of geothermal projects is usually limited to areas where drilling costs are on a relatively low level due to steep geothermal gradients or a favourable geological setting.⁹

Natural hydrothermal systems produce geothermal fluid without any added technological help. For this, a natural heat source and rocks with enough permeability to allow a convection-dominated system are required. These systems are most usually found at tectonic plate boundaries, where steep geothermal gradients and local high permeability

formations are commonly found.¹⁰ Water in hydrothermal systems is often of meteoric origin. Water falls as precipitation and percolates through permeable layers until it reaches the heat source (e.g. magmatic intrusion), heats up and travels upward towards the surface.

In general, natural hydrothermal systems can be further divided into two categories: vapour dominated systems and liquid dominated systems. A vapour-dominated system is generally formed if the reservoir pressure is high enough for the geothermal fluid to vaporize. These systems are comparatively easy to exploit and do not occur often. Vapour-dominated systems are commonly suitable for base load electricity production. Examples include Geysers in the USA and Larderello in Italy.¹¹ Liquid dominated systems are formed when the reservoir pressure does not allow boiling. These systems are more commonly found than vapour dominated systems, but are generally more difficult to produce from. This is largely due to the fact that the concentration of total dissolved solids (TDS) in the fluid can be a booster for scaling. Scaling can be a significant problem at the transition passage between a two-phase flow and a one-phase flow. This transition is made when the fluid is flashed.¹²

The applications of geothermal energy fall into three distinct classes. The classes indicate the type of applications that can be achieved, and are based on approximate temperature regimes of the geothermal fluid:

1. Geo-exchange (<30°C)
2. Direct use of geothermal heat (30°C – 150°C)
3. Geothermal power (>80°C)

Geo-exchange is used almost exclusively in residential/commercial space heating & cooling applications with the use of a heat pump and long loops of tubing at shallow depths. The commonly encountered ~10°C temperature found in moderate climate shallow soil beneath a building (from a few metres to a few hundred metres below the surface) can be used to cool the building on a hot summer day and to preheat fresh air coming in to the building on a winter day, ultimately taking some of the load off of the building's furnace. Geo-exchange systems often work by pumping a working fluid into a

Canadian Geothermal Energy Association
PO Box 1462 Station M, Calgary, Alberta, T2P 2L6, Canada
info@cangea.ca - www.cangea.ca



closed loop underground tubing system, which returns the fluid to the building at a the same temperature as the surrounding ground. This type of technology does not generate electricity.

As the temperature of the geothermal resource increases, we move into the range of direct use applications. These imply directly using the geothermal energy for heating and other industrial or commercial processes. Direct use operations often involve drilling to a certain depth and bringing geothermal fluid to the surface. Industrial uses include heating greenhouses in northern communities, aquaculture, pulp & paper manufacturing and many other applications that require moderate heating. In some areas, hot springs will find the surface naturally and the hot waters can be put to use without drilling.

At low temperatures the difference between geo-exchange and direct use geothermal can become blurry. The primary difference is that geo-exchange uses the ambient soil temperature (that is primarily heated by the sun) and a working fluid in a closed loop, whereas direct use geothermal utilizes geothermal fluid (that is heated by conduction and convection from Earth's core) often directly in the system, before re-injecting it back underground.¹³ At high temperatures, direct use implies using the geothermal fluid for anything but electrical generation. Direct use geothermal applications are found in a few places throughout Canada, most notably among commercial hot springs.¹⁴

Geothermal energy might be regarded as sustainable on a human time scale while the production of geothermal fluid stays below the level of recharge in the reservoir. The consequence is a reservoir specific sustainable production limit, which is characterized by the geological setup (e.g. rock porosity, aquifer characteristics, etc.).¹⁵ The constant heat flow generated by radioactive decay from the Earth's core is expected to continue radiating for billions of years, and with proper management, individual geothermal production fields can theoretically run indefinitely.

Global Geothermal Power Industry: Worldwide Utilization

The global geothermal power industry is a small player when compared to other forms of electricity generation. According to the US Energy Information Administration (EIA), only 0.32 percent of globally produced electricity came from geothermal sources in 2012.¹⁶

Within the geothermal field, the United States are by far the largest producer of electricity from geothermal sources. In 2013 the US reported an installed capacity of 3752.9 MW_e. This represents 31% of the global capacity. In the same year 22% of geothermal electricity produced worldwide originated from the US. Table 1 displays the installed capacity and the energy produced in 2013 for the Geothermal Implementing Agreement (GIA) countries that produce electricity from geothermal resources. Notable producers of geothermal electricity outside of the GIA are the Philippines with roughly 1,900 MW and Indonesia with 1,300 MW of installed capacity. Turkey, Kenya and El Salvador are other countries outside of the GIA, which contribute largely to the worldwide electricity generation from geothermal sources. These 14 countries (9 GIA + 5 non-GIA) contribute to almost 98% of the worldwide geothermal electricity generation.

The capacity factor for 2013 within the different countries varies tremendously. It ranged from 0.05 in Australia to 0.90 in Iceland. A low capacity factor can be explained by maintenance or not fully finished construction work.¹⁷

Table 1: Geothermal power production in 2013¹⁸

Country	Installed Capacity (MW _e)	Produced Energy (GWh/a)
Australia	1.1	0.5
France	17.2	80.6
Germany	30.1	54.5
Iceland	665.0	5,245.0
Italy	875.5	5,695.0
Japan	515.1	2,620.4
Mexico	1,017.0	6,070.0
New Zealand	1,042.0	6,053.0
USA	3,752.8	16,517.0
Total GIA	7,915.8	42,300.1
Total World	12,000.0	76,000.0

When looking at the global trends in the geothermal industry, it is remarkable that the global installed capacity grew by almost 35% from 2005 to 2013. Within the GIA, the growth was even faster and totals up to 45%. A detailed overview of the installed capacities for the electricity producing GIA countries is displayed in Table 2.¹⁹ In general, the industrial growth seems to be on a stable level and is not forecasted to slow down.

The actual electricity generation for 2013 came in at a level of 76,000 GWh, which represents a 6% increase from 2012 and a 36% increase from 2005. Table 3 gives an overview of the annual electricity generation in GWh/a for the nine electricity generating GIA countries.²⁰

Table 2: Installed electric capacities 2005-2013 (MW_e)²¹

Country	2007	2008	2009	2010	2011	2012	2013
AUS	0.1	0.1	0.1	0.1	0.1	0.1	1.1
F	15.0	17.2	17.2	18.3	17.7	17.7	17.2
GER	3.2	6.6	6.6	7.3	7.3	11.1	30.1
ICE	485.0	575.0	575.0	575.0	664.6	664.6	665.0
IT	810.0	810.5	842.5	882.5	882.5	874.5	875.5
JP	535.3	535.3	535.3	537.7	540.1	540.1	515.1
MX	958.0	958.0	958.0	958.0	958.0	958.0	1,017.0
NZ	452.0	632.0	632.0	792.0	794.0	794.0	1,042.0
USA	2,936.5	3,040.0	3,168.0	3,101.6	3,111.0	3,386.0	3,753.8
Total GIA	6,195.1	6,574.7	6,734.7	6,872.6	6,975.3	7,246.1	7,915.8
Total World	9,732.0	Na	Na	10,898.0	11,244.0	11,600.0	12,000.0

Table 3: Geothermal electricity produced 2005-2013 (GWh/a)²²

Country	2007	2008	2009	2010	2011	2012	2013
AUS	0.5	0.8	0.6	0	0.6	0.5	0.5
F	95.0	90.0	89.0	14.9	56.6	50.6	80.6
GER	0.4	18.0	19.0	27.5	18.7	25.4	54.5
ICE	3,600.0	4,000.0	4,553.0	4,465.0	4,701.0	5,210.0	5,245.0
IT	5,233.0	5,181.0	5,200.0	5,376.0	5,315.0	5,235.0	5,659.0
JP	3,102.0	3,064.0	2,765.0	2,908.0	2,652.2	2,688.8	2,620.4
MX	7,393.0	7,056.0	6,740.0	6,618.0	6,524.0	5,817.0	6,070.0
NZ	3,354.0	3,966.0	4,589.0	5,500.0	5,774.0	5,843.0	6,053.0
USA	14,500.0	15,000.0	15,000.0	15,000.0	16,7000.0	16,791.0	16,517.0
Total GIA	37,277.9	38,375.8	38,955.6	39,968.4	41,742.1	41,611.3	42,300.1

Total World	59,676.6	Na	Na	67,246.0	69,372.0	71,564.7	76,000.0
--------------------	-----------------	-----------	-----------	-----------------	-----------------	-----------------	-----------------

Types of Geothermal Power Plants

Generally speaking, four different types of geothermal power plants exist. Each type is connected to a specific hydrogeological setting and serves the purpose of power production. All four types work by the principle of powering a steam turbine. The four types are²³:

- Dry Steam Geothermal Plants
- Flash Geothermal Plants
- Binary Plants
- Enhanced Geothermal System Plants

Flash Geothermal Plants

Flashing power plants are generally quoted as the most common form of geothermal power plants and can be found in most developed geothermal areas around the world. Flashing power plants are commonly used, when the reservoir provides a liquid dominated geothermal fluid of high temperature. The geothermal fluid is usually brought to the surface under pressurized conditions. The pressure is released gradually in a so-called flash tank or chamber, which leads to partial vapourization of the fluid. The flashing process can theoretically also be initiated at different locations (e.g. in the production well). The exact location of the flashing point can be of importance for the operation and maintenance of the power plant.

After flashing, the steam/liquid mixture enters a separator, which separates the liquid from the vapour phase. A high level of steam quality (as dry as possible) is of significant importance, as droplets of liquid can cause corrosion and/or scaling within the pipes and turbine parts, which is undesirable as it leads to additional maintenance and costs.

The vapour phase is then used to run a turbine and generate electricity. When exiting the turbine, the steam runs through a condenser, where another phase change occurs.

The condensed liquid is mixed with the original liquid phase and might be used for reinjection in order to maintain the pressure of the geothermal system.

The flashing process can be repeated in order to enhance the power output that is achievable from the geothermal resource. Double flashing follows the same principles as single flashing but allows gaining between 15% and 25% more power from a given geothermal fluid. However, double flashing power plants are more expensive and need more maintenance than single flashing power plants.

Before reinjection, the geothermal brine can also be cascaded down to further industrial uses in order to access the excess heat, which can be gained from the brine.²⁴

Dry Steam Geothermal Plants

Dry steam power plants are the simplest form of geothermal power plants and can only be operated in vapour dominated high temperature geothermal fields, within which the fluid contains almost no liquid. These fields are not very common and it is estimated that only 5% of all high temperature (>200°C) systems are of this nature. Large-scale projects are currently located in the Geysers area in California and in Larderello, Italy. In ideal conditions the dry steam can be extracted easily and used directly for electricity generation by piping it to a turbine, which in turn runs a generator.²⁵

Binary Geothermal Plants

Binary power plants are technically closer to conventional fossil or nuclear-fuelled power plants, as electricity is generated via a vapourized working fluid that flows in a closed cycle. Binary power plants are commonly used when the reservoir temperature is not high enough to produce a usable vapour phase in the geothermal fluid. The fluid is pumped to the surface and flows through a heat exchanger that transfers the heat to the closed working fluid cycle. The working fluid usually has a lower boiling point than the geothermal fluid and can be chosen in accordance to the reservoir temperature. The vapourized working fluid is then used to run a steam turbine. After exiting the turbine, the

fluid flows through a condensation unit and is consequently ready for the next vapourization cycle.

The efficiency of binary power plants is limited and commonly lower than efficiencies for flashing or dry steam plants. One frequently quoted advantage is the closed cycle technology, which allows no interaction between the geothermal fluid and the ambient environment. Consequently, carbon dioxide and hydrogen sulphide emissions are limited to a minimum.

Examples of binary cycle power plants include Mammoth Lakes in California and Te Huka in New Zealand.²⁶

Enhanced Geothermal Systems (EGS)

Many locations on Earth have a relatively steep geothermal gradient but are characterized by insufficient fluid content or permeability of the underlying rock. These systems are called hot dry rock (HDR) formations or enhanced geothermal systems (EGS). Given a sufficient borehole depth, such systems are available at any location - creating a very large resource base. However, access is restricted heavily by economic factors such as drilling and infrastructure cost. Nevertheless, the ubiquitous nature of EGS is a feature that puts EGS on many research agendas worldwide.

The technology behind it is hydroshearing, which can easily be mistaken for hydraulic fracturing, a technology well known from the oil and gas industry. A partially horizontal injection well is drilled and a fluid is pumped into the ground. Hydroshearing uses much lower pressure than hydraulic fracturing. Within the rock formations very small cracks open and consequently create a fairly large surface area for heat exchange. As an application for the geothermal industry, the water is heated up in the hot rock formation and is pumped up through a production well. On the surface the geothermal fluid can be used in flashing or binary systems.²⁷ Another main difference between hydraulic fracturing and hydroshearing is that the hydroshearing fluid is usually H₂O.

Cascaded Uses & Combined Uses

Geothermal resources have the possibility to satisfy many needs: power generation, space heating, greenhouse and aquaculture pond heating, industrial processing, and bathing to name a few. Considered individually; however, some of the uses may not promise an attractive return on investment because of the initial capital cost. Thus, it is beneficial to consider using the geothermal fluid several times to maximize benefits. This multistage utilization, where higher and lower water temperatures are used in successive steps, is called cascading or waste heat utilization. A simple form of cascading employs waste heat from a power plant for direct use projects referred to as a combined heat and power application (Figure 1)²⁸.

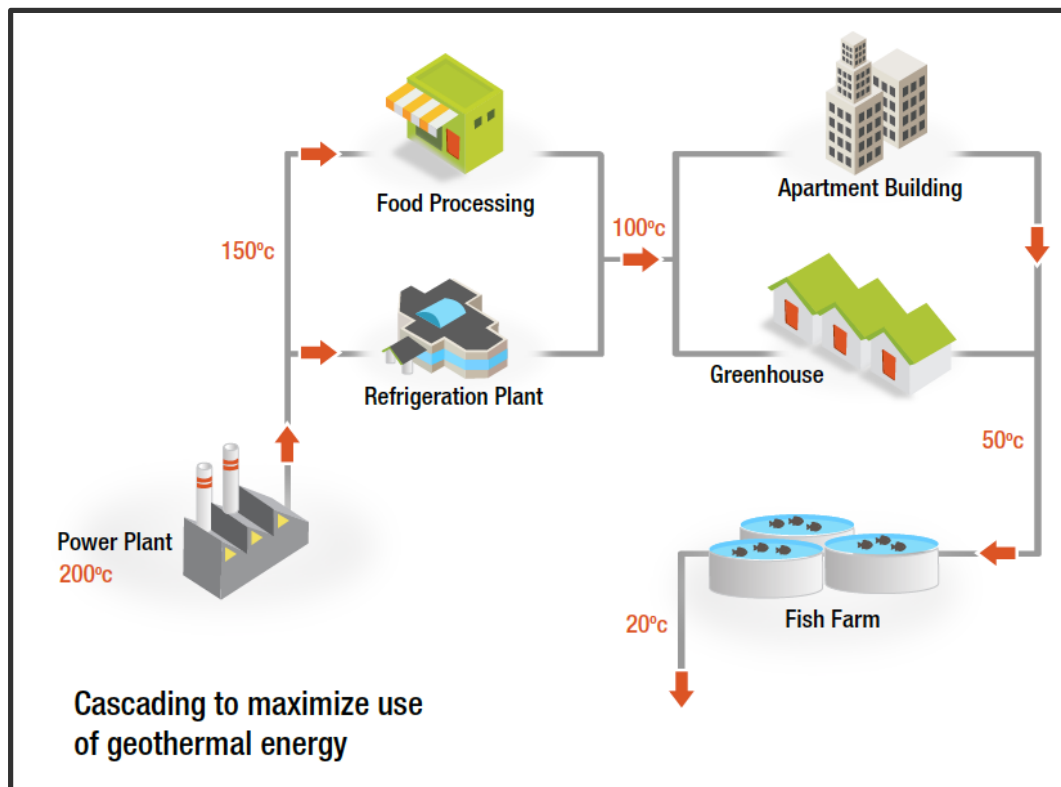

Figure 1: An example of cascading for combined heat and power

Geothermal cascading has been proposed and successfully attempted on a limited scale throughout the world. In Rotorua, New Zealand, for example, after geothermal water and steam heats a home, the owner will often use the waste heat for a backyard swimming pool and steam cooker. At the Otake geothermal power plant in Japan, about 165 tonnes per hour of hot water flows to downstream communities for space heating,

Canadian Geothermal Energy Association
PO Box 1462 Station M, Calgary, Alberta, T2P 2L6, Canada
info@cangea.ca - www.cangea.ca



greenhouses, baths and cooking. In Sapporo, Hokkaido, Japan, the wastewater from the pavement snow melting system is retained at 65°C and reused for bathing. Examples of combined heat and power installations using geothermal water down to 100°C are installed in Germany and Austria. At Neustadt Glewe in north Germany 98°C water from a 2,300 meter-deep well at 1,700 l/s provides 11 MWt for a district heating network and 210 kWe for a binary power plant meeting the electricity demands for 500 households²⁹.

Another interesting example of cascaded use can be found on the Reykjanes peninsula in Iceland. There, the Svartsengi power plant, which is owned by the Canadian company Alterra Power Corp, is rated at 74 MWe and produces electricity and hot water for the surrounding municipalities.³⁰ The brine of the power plant is partly used in the Blue Lagoon, a spa that receives thousands of visitors per year.³¹ As the geothermal fluid from Svartsengi has high silica content, a cosmetics line was developed, which uses Silica and minerals that have been extracted from the geothermal brine. This business model has proven itself to be tremendously successful in Iceland.

Only a short drive from Svartsengi, the Reykjanes power plant uses its thermal energy to heat up air, which is then used in a fish drying plant, owned by Haustak hf. Haustak exports a significant percentage of its production to Africa.³² The geothermal brine is used for district heating and snow melting applications in the surrounding area.

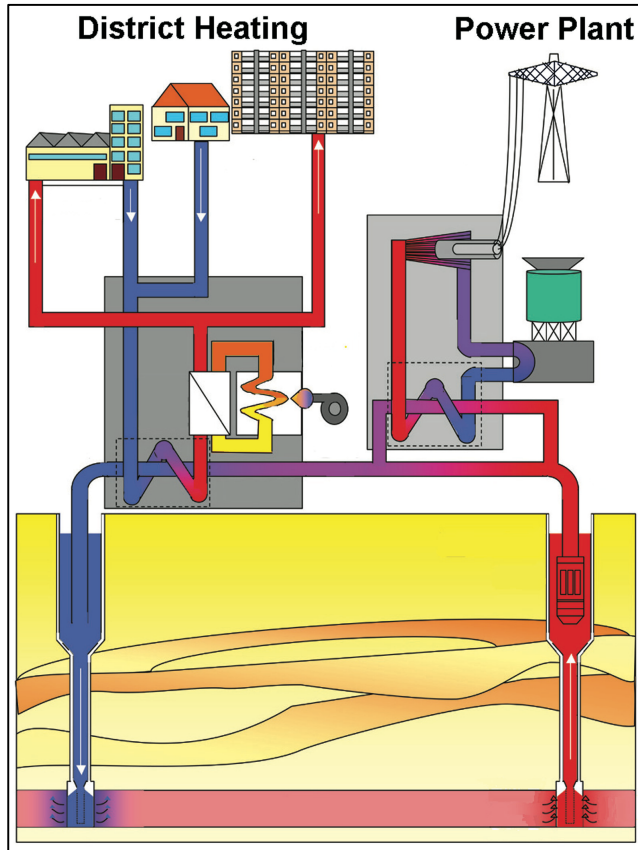

Figure 2: Schematic of combined geothermal heat and power utilization at Neustadt Glewe, Germany

There are many possible uses of geothermal fluid for direct-use applications; however, a number of parameters can limit the choices and need to be determined in advance. First, what are the characteristics of the resource (i.e. temperature, flow rate, chemistry and land availability)? Second, what markets are accessible and is the right expertise available to provide the product, whether it is heat energy, a crop of plants or fish, drying of a product (lumber or food), or extracting a mineral from the fluid, and will it be possible to get the product to the market economically? Finally, what are the capital investments, annual income, and rate of return on investment and/or payback period, and is it possible to raise the funds or find investors?

Potential applications include, but are not limited to:

- Heating/Cooling
- Food drying

Canadian Geothermal Energy Association
PO Box 1462 Station M, Calgary, Alberta, T2P 2L6, Canada
info@cangea.ca - www.cangea.ca



- Horticulture
- Aquaculture
- Snow Melting
- Mineral Extraction
- Cosmetics
- Etc.



Direct Use of Geothermal Heat

Yukon Geothermal Energy Report
2016

Scope

Direct-use of geothermal energy consists of various forms of heating and cooling applications and contrasts converting the energy for electric power generation. The primary forms of direct-use include swimming, bathing and balneology (therapeutic use), aquaculture applications (mainly fish pond and raceway heating), agricultural applications (greenhouse heating, crop drying and heating of buildings housing livestock in order to increase growth rates), space heating and cooling including district systems (the heating or cooling of several buildings from a single system), snow melting, industrial processes (such as mineral extraction and refining, drying or curing of building products such as lumber and concrete, and dehydration of food products), and geothermal and ground-source heat pumps (GHP) (for both heating and cooling). In general, the geothermal fluid temperatures required for direct-heat use, are lower than those for economic electric power generation (with the exception of binary cycles).

Most direct-use applications use geothermal fluids in the low-to-moderate temperature range between 50°C and 150°C. In general, reservoirs with these temperatures can be exploited by conventional water well drilling equipment³³. Low-to-moderate temperature systems are also more widespread than high-temperature resources (above 150°C), and are therefore more likely to be located near potential users and at shallow drilling depths (up to 1,000 m). In the United States, for example, of the 1,350 known or identified geothermal systems, 5% are above 150°C, 10% between 90°C and 150°C, and 85% are below 90°C³⁴. Almost every country in the world has some low-to-moderate temperature systems; while only a few have accessible high-temperature systems.

Traditionally, direct-use of geothermal energy has been on a small scale (<1 MWt), for uses such as in heating of a swimming pool or an individual home. More recent developments involve large-scale projects (>1 MWt), such as district heating (Iceland and France), greenhouse complexes (Hungary, Russia and Kenya), or major industrial uses (New Zealand and the United States). Heat exchangers are also becoming more efficient and better adapted to geothermal projects, allowing the use of lower temperature water and highly saline fluids. The geothermal heat is transferred through the heat exchanger to a benign or treated secondary fluid to prevent corrosion and

scaling of equipment in the secondary system. Heat pumps utilizing very low-temperature fluids (between 5°C and 30°C) have extended geothermal development into traditionally “non-volcanic countries” such as France, Switzerland and Sweden as well as areas of the mid-western and eastern United States. Most equipment used in direct-use projects is of standard, off-the-shelf design and needs only slight modification to handle geothermal fluids³⁵.

Global Geothermal Direct Use Industry: Worldwide Utilization

Worldwide the installed capacity of direct geothermal utilization in 2011 was 70,329 MWt and the annual energy use was 587,786 TJ (163,287 GWh) distributed among 82 countries. The leading countries are presented in Table 5.

This amounts to saving an equivalent 350 million barrel of oil annually, preventing 148 million tonnes of CO₂ being released to the atmosphere. The distribution of energy use among the various applications is listed in Table 5 and shown in Figure 3 for the worldwide installed capacity and Figure 4 for the annual energy use internationally. The largest usage groups are geothermal heat pumps (55.3%) (mainly for space heating) and bathing and swimming (20.3%). For comparison, the largest use in the United States is for geothermal heat pumps (83.8%)³⁶, whereas in Iceland the largest geothermal energy use is for district heating (71.8%)³⁷. As can be seen from Table 5, heat pumps have low load factors (USA), whereas industrial uses have high load factors (New Zealand), due to the more continuous use in their industrial processing. The leading user of geothermal energy, in terms of market penetration, is Iceland, where more than 89% of the population enjoys geothermal heat in their homes from 29 district heating services, and 62% of the country’s primary energy use is supplied by direct-use and electrical energy derived from geothermal resources³⁸.

Table 4: Geothermal power production in 2013³⁹

Country	GWh/yr	MWt	Main Application
China	48,435	17,870	GHP / Bathing
USA	21,075	17,416	GHP
Sweden	14,424	5,600	GHP
Turkey	12,536	2,886	District Heating
Japan	7,259	2,186	GHP / Bathing

Iceland	7,442	2,040	District Heating
France	4,408	2,347	GHP / District Heating
Germany	5,426	2,849	GHP
Norway	2,295	1,300	GHP

Table 5: Summary of the various categories of direct-use worldwide in 2015⁴⁰

Use	Capacity MWt	Utilization TJ/yr	Capacity Load Factor
Greenhouses	1,830	26,662	0.46
Aquaculture	695	11,958	0.55
Space Heating	7,556	88,222	0.37
Agricultural Drying	161	2,030	0.40
Industrial uses	610	10,453	0.54
Bathing/Swimming	9,140	119,381	0.41
Cooling/Snow Melting	360	2,600	0.23
GHP	49,898	325,028	0.21
Other	79	1,452	0.58
Total	70,329	587,786	0.27

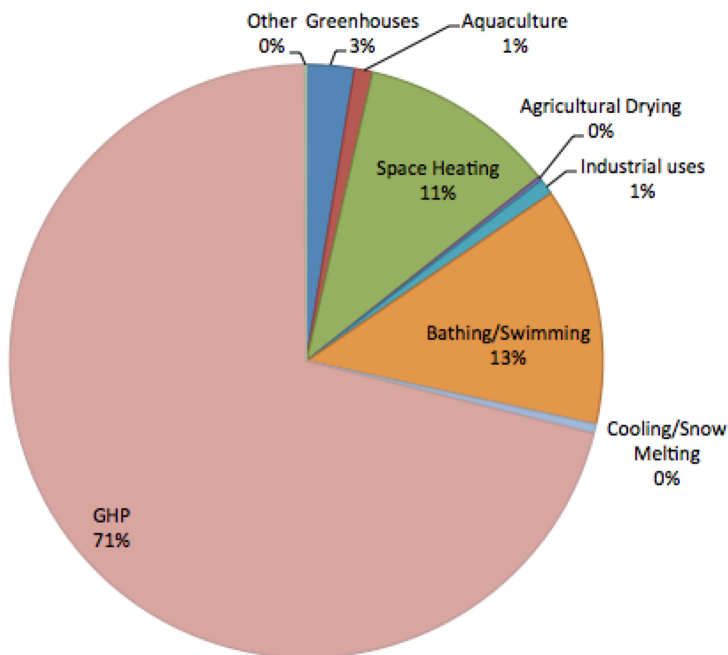

Figure 3: Geothermal direct use applications worldwide in 2010, distributed by percentage of total installed capacity (MWt)⁴¹

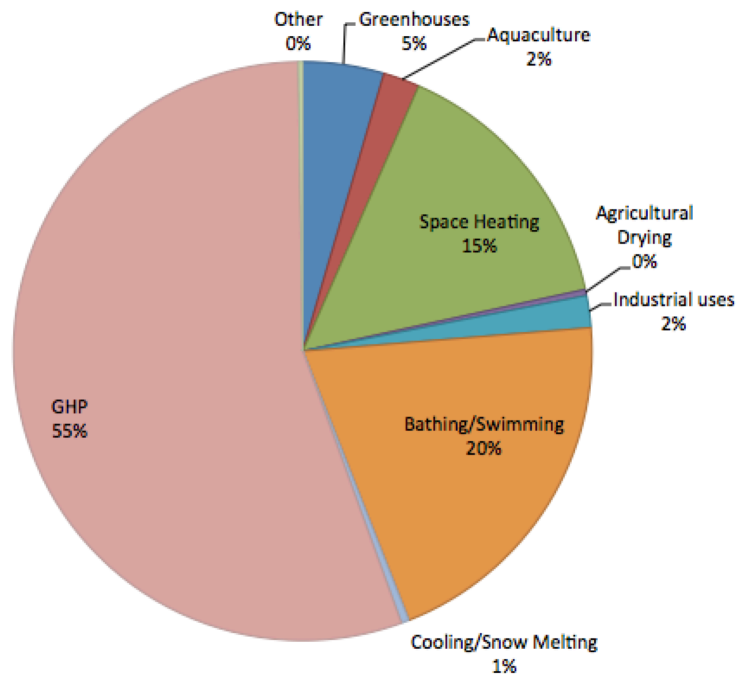

Figure 4: Geothermal direct use applications worldwide in 2010, distributed by percentage of total energy usage (TJ/yr)

Greenhouses and Covered Ground Heating

Numerous commercially marketable crops have been raised in geothermal heated greenhouses in Hungary, Russia, New Zealand, Japan, Iceland, China, Tunisia, Kenya, and the United States⁴². These include vegetables, such as cucumbers and tomatoes, flowers (both potted and bedded), houseplants, tree seedlings and cacti. Using geothermal energy for heating reduces operating costs (which can account for up to 35% of the product cost), and allows for operation in colder climates where a commercial greenhouse using fossil fuels for heating would not normally be economical⁴³. The optimization of growth using geothermal energy is illustrated in Figure 5, showing the narrow crucial temperature range for optimum growth.

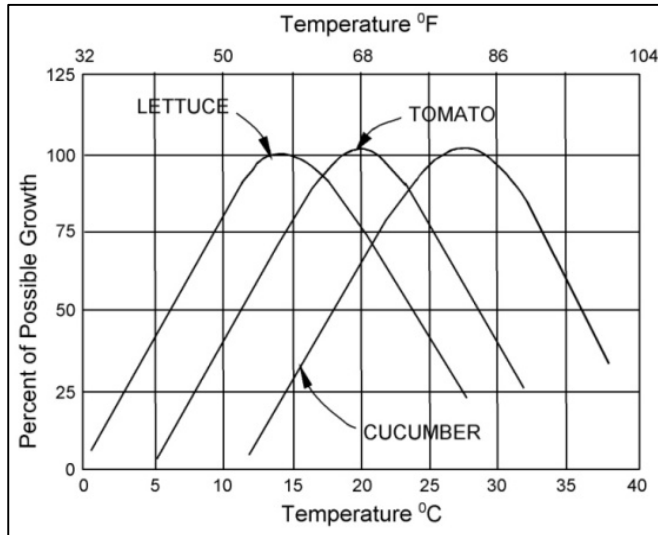

Figure 5: Optimum temperature for growing various vegetables

Worldwide there are approximately 1,333 ha of greenhouses heated with geothermal energy with an installed capacity of 1,830 MWt utilizing 26,662 TJ/yr in 31 countries. The average energy use is 20 TJ/yr/ha.⁴⁴ The leading countries for annual energy use are Turkey, Russia, Hungary, China and Italy; however, most do not distinguish between covered greenhouses versus uncovered ground heating. Again, there are no geothermal-heated commercial greenhouses in Canada, but the conventional greenhouse industry is prominent, particularly in British Columbia where substantial geothermal potential exists. One attempt at establishing an operation was made in the 1980s, but failed when an aquifer could not be intersected.

Ground covered with plastic has been used in Iceland and northern Greece (asparagus) to insulate crops in cold weather and start the growing season earlier. Earlier annual market entry can lead to increased profit due to the lack of competition. In the Yukon an extended growth period can have a significant impact on vegetable and fruit availability in remote communities.

The economics of geothermal greenhouse operation depend on many variables, such as crop type, climate, resource temperature, type of structure, market, etc. Peak heating requirements in a temperate climate zone are around 1.0 MJ/m², and a 2.0 ha facility

Canadian Geothermal Energy Association
PO Box 1462 Station M, Calgary, Alberta, T2P 2L6, Canada
info@cangea.ca - www.cangea.ca



would require 20 GJ/yr (5.5 MWt) of installed capacity. With a typical load factor of 0.50, the annual energy consumption would be approximately 90 TJ/yr (25 million kWh/yr).

Aquaculture

Aquaculture involves the raising of freshwater or marine organisms in a controlled environment to enhance production rates. Temperature control is generally more important for aquatic species than land animals. When water temperature falls below the optimal range, the basic body metabolism of fish is altered, causing them to lose their ability to feed. Geothermal energy can be used to maintain a stable optimum temperature throughout day and night. Ponds and raceways are therefore not prone to temperature changes due to varying amounts of radiation from the sun. This can increase the species growth rate by 30 to 50 percent. Figure 6 illustrates how critical temperature control is for aquatic species compared to domestic, terrestrial animals.

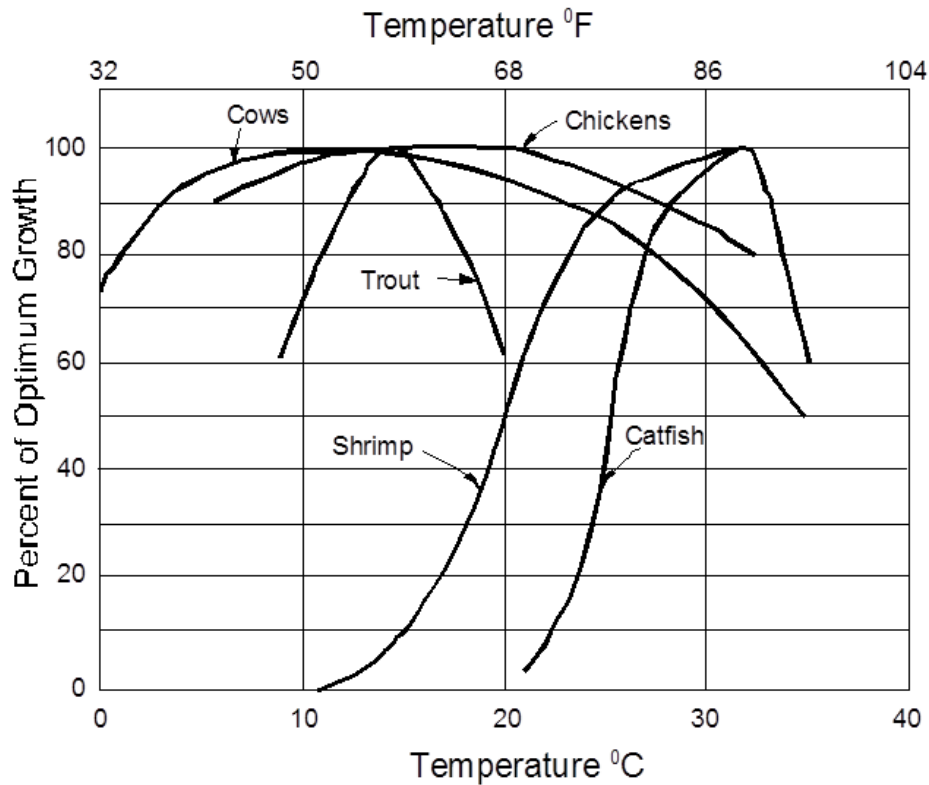

Figure 6: Growth rate of aquatic species compared to land animals

Aquaculture applications are particularly attractive, as they require heating at the lower end of the temperature range where there is an abundance of geothermal resources. Use of “waste heat” or the cascading of geothermal energy also has excellent possibilities as discussed earlier in this report.

In a temperate climate, a pond exposed to the elements uses about 2.5 times the energy for heating as a covered pond. A covered pond allows for working indoors during inclement weather, and protects the crops from birds and various land predators. Most ponds are shallow, about one meter in depth, with the long axis placed perpendicular to the prevailing wind to minimize heat loss for outdoor locations. Based on work in the United States, the geothermal requirement for uncovered ponds is estimated at 0.242 TJ/yr/tonne of fish (bass and tilapia). A typical outdoor pond in a temperate climate zone would require 2.5 MJ/hr/m² and a 2.0 ha facility would require an installed capacity of 50 GJ/yr (14 MWt).⁴⁵ With a load factor of 0.60, the annual heating requirement would

be 260 TJ/yr (73 million kWh/yr). A covered pond would have energy requirements similar to that of a greenhouse operation, or about 40% of the above figures.

Agricultural Drying

Drying and dehydration are important moderate-temperature uses of geothermal energy. Drying of various vegetable and fruit products is feasible with continuous belt conveyors or batch (truck) dryers heated by geothermal energy. Thirteen countries report the use of geothermal energy for drying purposes. Examples include: seaweed and fish (Iceland), onions (USA), wheat and other cereals (Serbia), fruit (El Salvador, Guatemala and Mexico), lucerne or alfalfa (New Zealand), coconut meat (Philippines), and lumber (Mexico, New Zealand and Romania)⁴⁶. A small, portable geothermal fruit drier for pears and apples has been tested in Mexico⁴⁷. This is an attempt to save some of the local crops for export that would normally spoil due to a lack of a local market.

An example of a small-scale food dehydrator in North-eastern Greece where four tonnes of tomatoes are dried annually shows that economically viable options do not need a lot of manpower. The plant is operated by only three employees⁴⁸.

At the other end of the spectrum is the large-scale onion and garlic drying facilities located in western Nevada, USA employing 75 workers⁴⁹. These continuous belt driers are fed 3,000 to 4,300 kg/hour of onions and after 24 hours produce 500 to 700 kg/hour of dried product. Figure 7 is a simplified sketch of a continuous belt dryer. The plant uses between 50 to 75 l/s of geothermal fluid at 110°C cascading it down to around 70°C before disposal. The fluid is still hot enough to be cascaded down to space heating or snow melting purposes.

Preserving food by drying is an interesting possibility for remote communities in Canada as well. If geothermally heated greenhouses are used to enhance food security by extending growth periods an overproduction can be achieved. The surplus in production of vegetables and fruit could be dried by geothermal heat in order to make it suitable for storage and consumption in the winter months. Additionally, remote communities could spark economic growth by drying caught fish and transporting it to larger markets. Dried

fish would avoid the problem of keeping fresh fish edible during the waiting time for large-scale transportation.

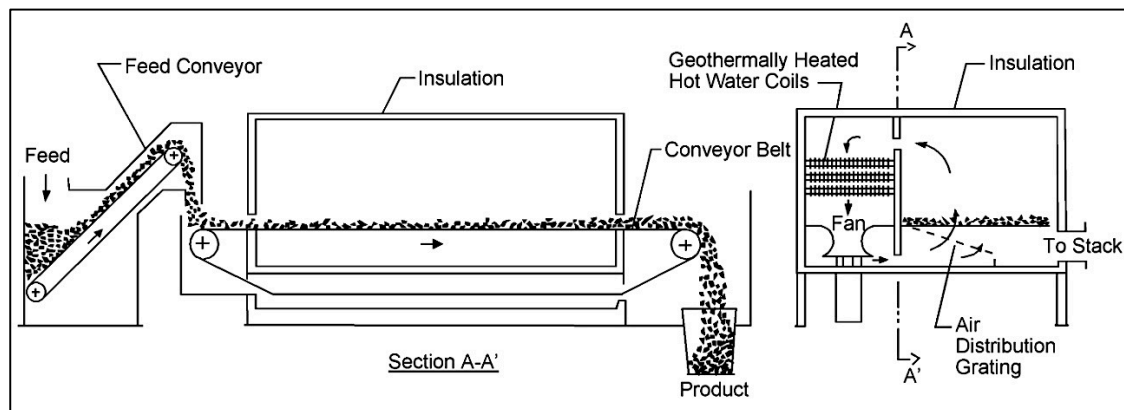

Figure 7: Continuous belt dehydration plant, schematic

Swimming, Bathing, & Balneology

People have used geothermal water and mineral waters for bathing for many thousands of years. Balneology, the practice of using natural mineral water for the treatment and cure of disease, also has a long history.

Some of the Native Americans and First Nations consider hot springs as sacred places and believe in the healing powers of the heat and the mineral content. Every major hot spring in the U.S. has some record of use by Native Americans, some for over 10,000 years.

There are approximately 157 known hot springs in the country, most in British Columbia and some in the other western provinces and territories. There are currently 12 commercial operations, all in Western Canada, that account for the majority of geothermal heat utilization in the country, which stands at 8.8 MWt. Some of the more famous commercial ones are located along the western slopes of the Rocky Mountains, such as Harrison, Banff, Radium, Fairmont and Miette hot springs. All were developed in the late 1800's and early 1900's and can be considered popular destinations for tourism and the general public.⁵⁰ One notable example of a non-hot spring geothermal spa is

the Temple Gardens Mineral Spa in Moose Jaw, Saskatchewan, which led to the revitalisation of the entire town in the early 2000's.

According to the American Society of Heating and Air Conditioning Engineers⁵¹, the desirable temperature for swimming pools is 27°C, however, this will vary from culture to culture by as much as 5°C⁵². Any design must consider all of the following variables: humidity control, ventilation requirements for air quality (outdoor and exhaust air), air distribution, duct design, pool water chemistry and evaporation rates.

Industrial and Process Heating Applications

Although there are many potential industrial and process heating applications of geothermal energy, the current uses globally are relatively few. Examples of current use include: concrete curing (Guatemala and Slovenia), bottling of water and carbonated drinks (Bulgaria, Serbia and the United States), milk pasteurization (Romania), leather preparation (Serbia and Slovenia), chemical extraction (Bulgaria, Poland and Russia), CO₂ extraction (Iceland and Turkey), and iodine and salt extraction (Vietnam)⁵³

Milk pasteurization was attempted in Klamath Falls, Oregon (USA) for a number of years. The geothermal fluid was pumped from the well at 87°C into the building and through a three-section plate heat exchanger. The incoming cold milk at 3°C was pre-heated by milk coming from the homogenizer in one section of the plate heat exchanger. The milk was then passed to the second section of the plate heat exchanger where the geothermal fluid heated the milk to a minimum temperature of 78°C for 15 seconds. Once the milk was properly pasteurized, it was cooled to 12°C by the incoming cold milk. It was finally chilled to 3°C by cold water in the third section of the plate heat exchanger. Figure 8⁵⁴ displays the according flow diagram.

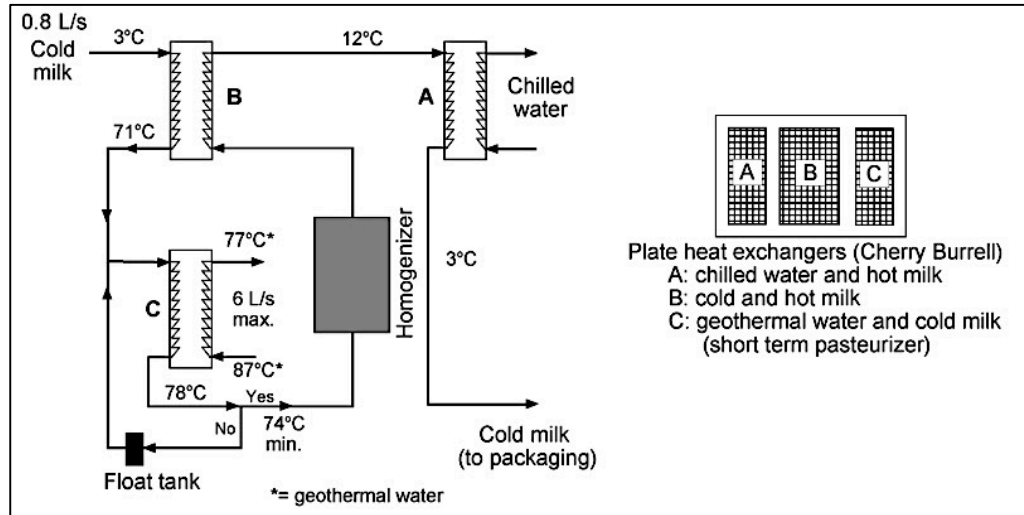

Figure 8: Klamath Falls milk pasteurization flow diagram

Several unusual developments in the use of geothermal fluids include the enhanced heap leaching of precious metals (gold and silver) in Nevada (USA).⁵⁵ Alcohol fuel production has been attempted in Idaho with canola seeds (USA) and bio-diesel production in Nevada and Oregon from vegetable oil (USA); however, the economics were marginal.⁵⁶

As expected, because of almost year-around operation, heat use for industrial processes has the highest capacity factor of all direct uses^{57,58}.

Space Conditioning

Distributed Space Conditioning

Distributed space conditioning includes both heating and cooling in standalone structures such as single buildings and houses. Space heating with geothermal energy has widespread application, especially on an individual basis. Absorption space cooling with geothermal energy has not been as popular because of higher temperature requirements. However, newer units recently placed on the market report to use temperatures below 100°C efficiently.

An example of space heating and cooling with low-to-moderate temperature geothermal energy is the Oregon Institute of Technology in Klamath Falls, Oregon (Figure 9). Here sixteen buildings covering 76,000 m² of floor space are heated with water from three wells at 89° to 91°C. Up to 62 l/s of fluid can be provided to campus with the average heat utilization rate over 0.53 MWt and peak at 5.6 MWt. Earlier, a 1,095 kW (312 tons) chiller required up to 38 l/s of geothermal fluid and produced 23 l/s of chilled fluid at 7°C to meet the campus cooling base load. The savings in heating costs on campus, compared to using diesel fuel, amount to over \$US 1 million per year. Recently a 280 kW geothermal binary electrical generating plant was installed on campus, using the well water first, taking approximately 10° to 15°C out of the geothermal water, before cascading it for campus space heating⁵⁹.

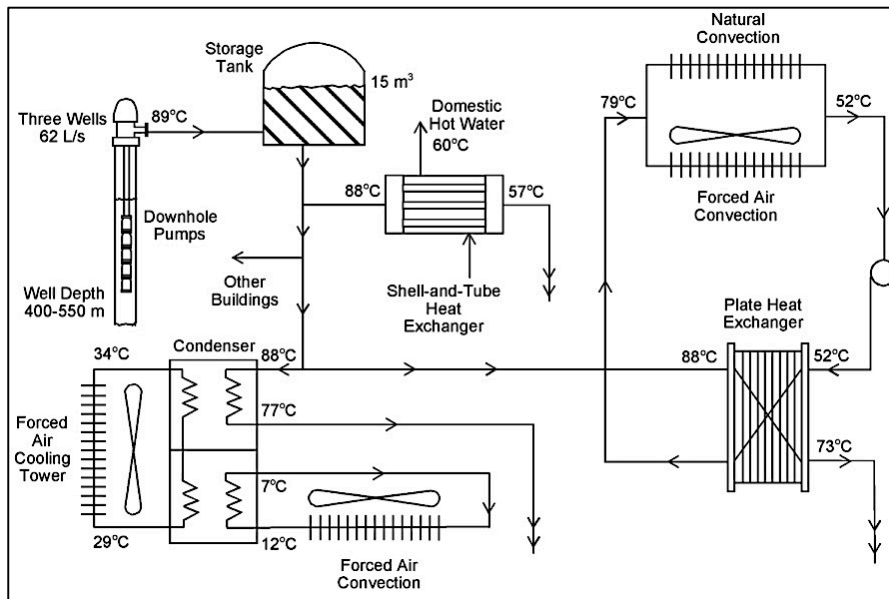

Figure 9: Oregon Institute of Technology heating and cooling system

Furthermore, two binary geothermal power units with a total installed capacity of 1.75 MWe were constructed. Assisted by a solar array, the system provides 100% of the campus electrical needs with renewable energy. The combination of using a binary cycle for electricity generation and heating applications might be viable for northern communities in Canada.

One of the important design considerations of space heating systems for individual buildings is the use of the down hole heat exchanger (DHE). These are used extensively in Klamath Falls, Oregon, Reno, Nevada, and Rotorua and Taupo, New Zealand.⁶⁰ The DHE eliminates the problem of disposal of geothermal fluid, since only heat is removed from the well. The exchanger consists of a system of pipes or tubes suspended in the well through which clean secondary water is pumped or allowed to circulate by natural convection. These systems offer substantial economic savings over surface heat exchangers where a single-well system is adequate, cutting the cost by as much as 50%. Typically, these systems produce less than 0.8 MWt, with well depths up to about 150 meters, and may be economical under certain conditions at well depths up to 500 meters.

Figure 10 and Figure 11 illustrate two examples of down hole heat exchanger installations in Klamath Falls, Oregon. The first (Figure 10) is typical of a residential system where both a 5-cm diameter heating loop and a 2-cm diameter domestic hot water loop is installed in the well. The second (Figure 11) is a larger installation at Ponderosa Middle School where two 10-cm and one 19-cm diameter heating loops are installed in the well providing 29 l/s of water at 77°C to the building. The system provides space heat, heated water for showers and restrooms for the 7,844 m² building, with a peak load of 2.3 GJ/hr (0.67 MWt) and 5.0 TJ/yr saving US\$69,000 per year⁶¹.

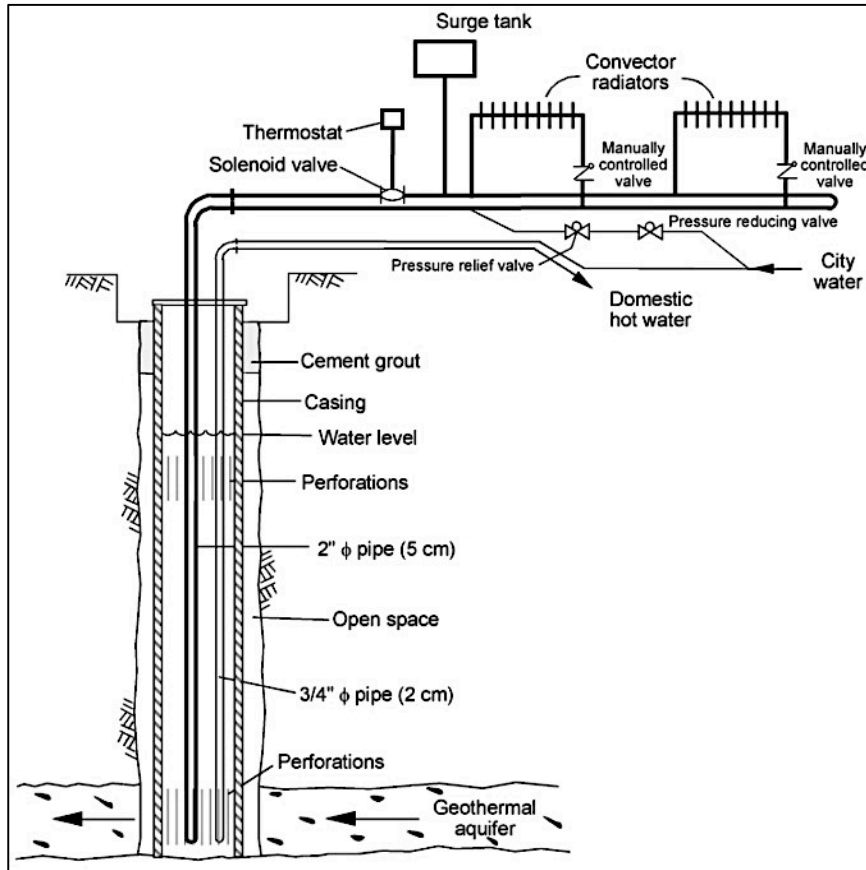

Figure 10: An example of a residential down hole heat exchanger installation

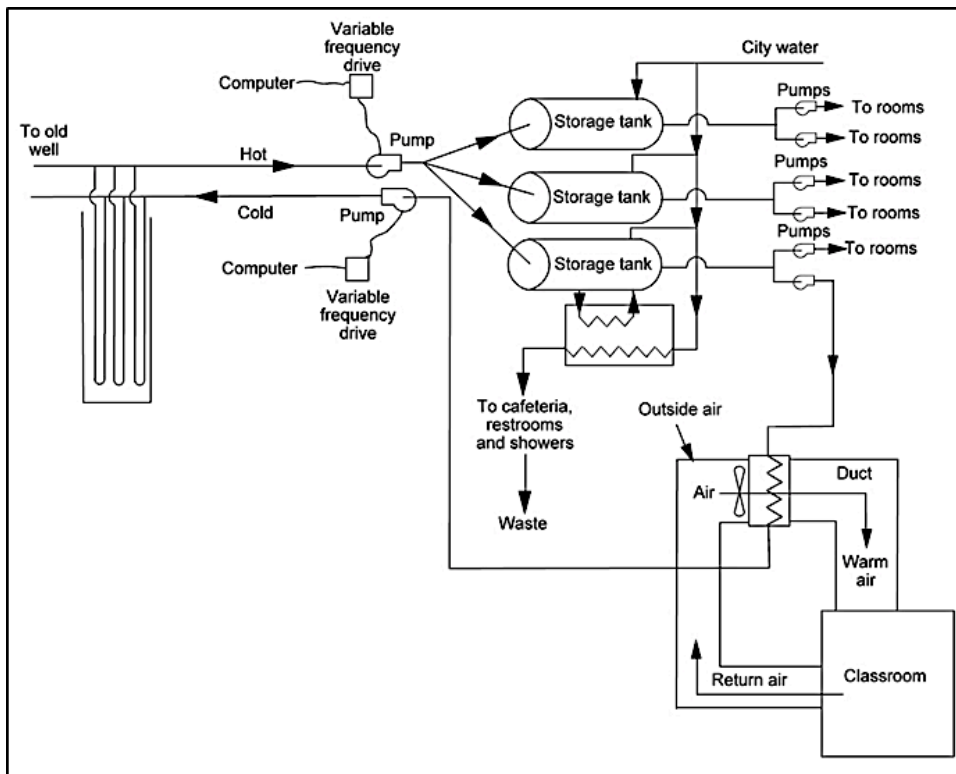

Figure 11: Down hole heat exchanger system at Ponderosa Middle School, Klamath Falls, Oregon

District Heating

In a district heating system, the hot water originates from a central reservoir. A piping system then distributes the hot water to separate buildings. Figure 12 displays a simplified sketch of a possible district heating application.

The Reykjavik district heating system in Iceland is by far the most famous example of this specific application of geothermal energy.⁶²⁶³ In Reykjavik, the hot water is supplied by the high temperature geothermal power station Nesjavellir. Here the geothermal brine is transported to Reykjavik via pipeline, where it is distributed. Additional sources of hot water are the low temperature areas Reykir, Laugarnes and Ellidaar.⁶⁴ After the space heating process, the water has a high enough average temperature to use it for snow melting applications. In addition to the geothermal heating system, a fossil fuel powered back up system is also available. Figure 13 displays the possibility of meeting peak demand with hydrocarbons. The Reykjavik district heating system is presented in Figure

17. The system supplies heat for a population of around 200,000 people. The installed capacity is approximately 700MWt.⁶⁵ During peak demand periods the increased load is met by large storage tanks and an oil-fired booster station, as mentioned above.⁶⁶

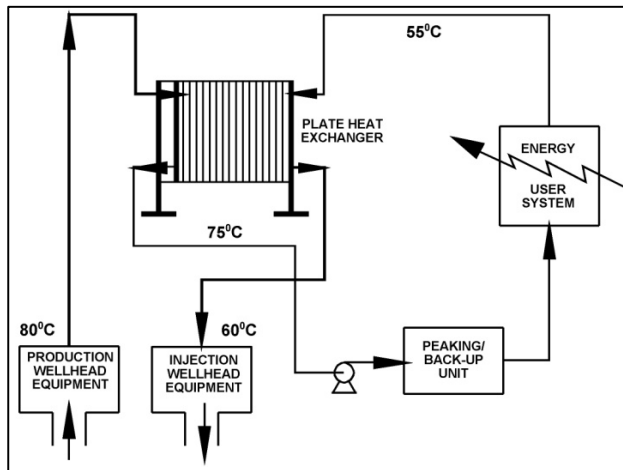

Figure 12: Geothermal direct-utilization system using a heat exchanger

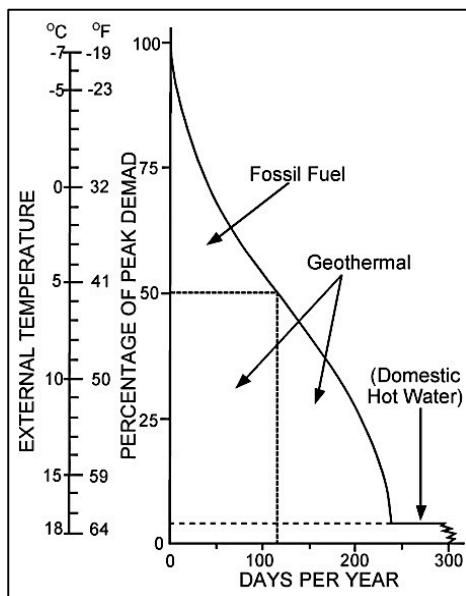

Figure 13: Meeting peak demand with fossil fuel

Geothermal district heating systems are in operation in 28 countries, including large installations in Iceland, France, Poland, Hungary, Turkey, Japan, China, Romania and

the United States.⁶⁷ While Canada has several district heating systems, which are growing in popularity, none are supplied fully by geothermal heat. The Cumberland Energy Authority is a partnership between the Municipality of the County of Cumberland, and the Town of Parrsboro, which are both located in Nova Scotia and pursue the use of local geothermal resources. In 2010 a study was established, which showed large alternative and renewable energy opportunities in the communities. Old mine shafts hold warm mining water, which has the potential of being used for district heating. The project is promising and currently ongoing. The Warm Springs Avenue project in Boise, Idaho, dating back to 1892 and originally heating more than 400 homes, is the earliest formal project in the United States.

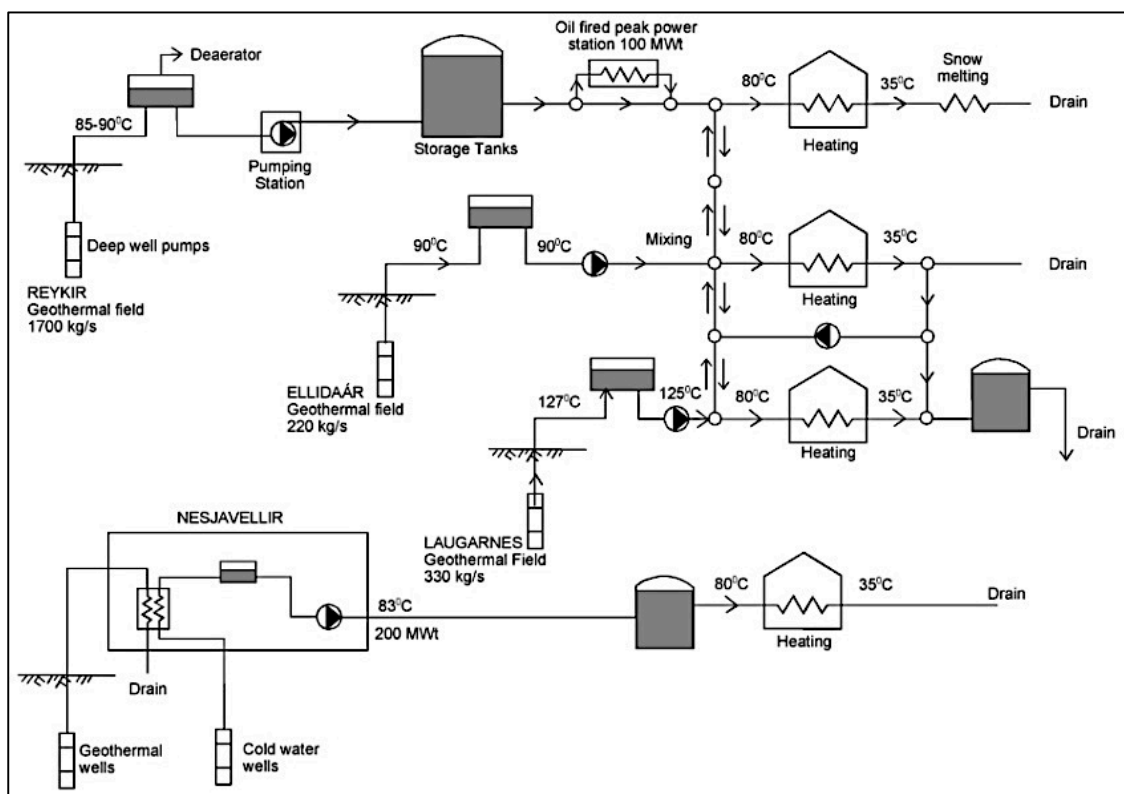

Figure 14: Reykjavik, Iceland district heating system

In France, production wells in sedimentary basins provide direct heat to more than 500,000 people in 166,000 dwellings from 34 projects with an installed capacity of 300 MWt and annual energy use of 4,900 TJ with a capacity factor of 0.52. These wells

provide from 40° to 100°C water from depths of 1,500 to 2,000 meters. As an example, in the Paris basin, one doublet system (one production and one injection well) can provide 70°C water, with the peak load met by heat pumps and conventional fossil fuel burners (Figure 15).⁶⁸

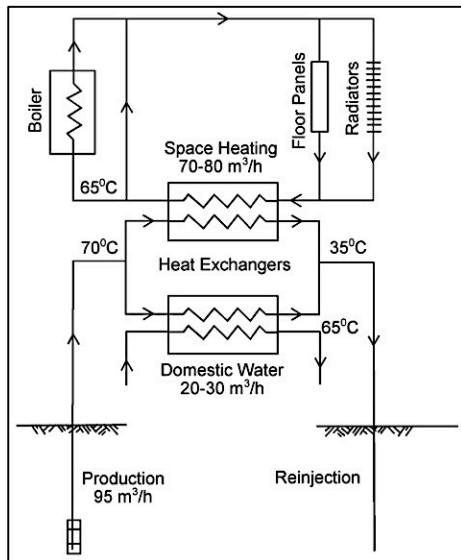

Figure 15: Example of a Melun I-Almont (Paris) doublet heating system

Economic operation of a district heating system is limited by the capital investment for the distribution network and the operating and maintenance cost. The distribution network can take up a significant portion of the project's cost.

An important consideration in district heating projects is the thermal load density, or the heat demand divided by the ground area of the district. High heat density, generally above 1.3 GJ/hr/ha (36 MW/km²), or a favourability ratio of 2.5 GJ/ha/yr is recommended⁶⁹.

Geo-Exchange Ground Source Heat Pumps

Geothermal heat pumps have the largest energy use and installed capacity worldwide as reported from 4 countries. While mentioned for completion, the technology falls under the domain of the Canadian Geo-exchange Coalition and is not covered under CanGEA's mandate. The leaders in installed units are the United States, China,

Sweden, Germany and the Netherlands.⁷⁰ Although, most of the installations are found in North America, Europe and China, the installations are increasing worldwide, as they can be installed anywhere using normal ground and groundwater temperatures between 5° and 30°C. They are normally installed in shallow holes up to 100 meters deep (closed-loop design), or using shallow groundwater wells (open-loop design) (Figure 16). The closed loop design can also be installed in horizontal trenches approximately two meters deep. These systems typically have a coefficient of performance (COP) of 3.0 to 4.0 (the ratio of heating or cooling energy output to electrical energy input from the compressor). The equivalent number of worldwide installed 12 kW units (typical of U.S. and European homes) is approximately 3.0 million. The size of individual units, range from 5.5 kW for residential use to large units of over 1,500 kW for commercial and institutional installations.

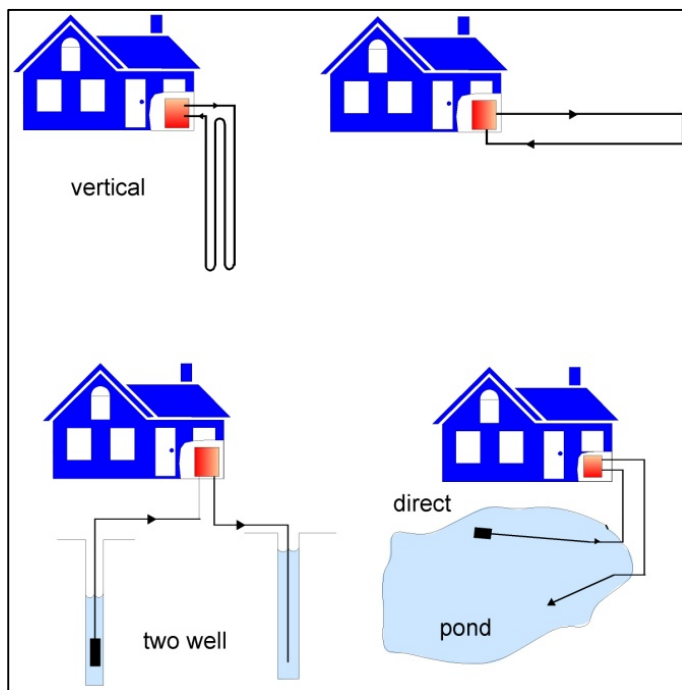

Figure 16: Typical ground-source and groundwater geothermal heat pump installations

In the United States, most units are sized for peak cooling load and are oversized for heating, except in the northern states; thus they are estimated to average only 2,000 full-load hours per year (capacity factor of 0.23). In Europe, most units are sized for the

heating load and are often designed to have the base load peaking provided by fossil fuel. As a result, these units may be in operation up to 6,000 full-load hours per year (capacity factor of 0.68), such as in Finland.

When operating during the heating mode, heat is removed from the ground or groundwater, whereas in the cooling mode heat is rejected into the ground or groundwater. If a balanced load cannot be maintained in a way to keep the ground temperature around the boreholes constant, a system such as cooling towers to dissipate heat or using passive solar to inject additional heat into the ground should be considered. Groundwater flow can also assist in supplying or removing heat from the boreholes. Even though the cooling mode does not use geothermal energy, credit can be taken for a reduction in fossil fuel use and greenhouse gas emission.

Snow Melting

Melting snow using geothermal heat may seem like a simple application, but it is limited by the expense of installation. Pavement and bridge deck snow melting projects are located in Argentina, Iceland, Japan, Switzerland, and the United States. A total of about two million square meters of pavement are heated worldwide, the majority of which is in Iceland. A project in Argentina uses geothermal steam for highway snow melting in the Andes to keep a resort community open during winter. In the United States, most of the pavement snow melting happens at the Oregon Institute of Technology campus and in the City of Klamath Falls. The power required varies from 130 to 180 W/m² (United States and Iceland) and is dependent on rate of snowfall, air temperature, relative humidity, and wind velocity. Piping materials are either metal or plastic; however, due to external corrosion problems, cross-linked polyethylene pipe (PEX) is now generally used instead of iron. Geothermal energy is supplied to systems through the use of heat pipes, directly from water circulating in pipes, through a heat exchanger or by allowing water to flow directly over the pavement⁷¹⁷²

Snow melting applications might be worth considering for larger Yukon settlements as clear roads reduce the risk of accidents and can significantly reduce travel times in the winter.

Canadian Geothermal Energy Association
PO Box 1462 Station M, Calgary, Alberta, T2P 2L6, Canada
info@cangea.ca - www.cangea.ca





Favourability Maps & Resource Base

Yukon Geothermal Energy Report

How We Made The Maps

This chapter gives an overview of the methodology that was used to create the resource estimates and the according maps.

Data Organization, Formatting, and Verification

A web portal provides public access to the Canadian National Geothermal Database (CNGD)⁷³. Data is organized based on specific criteria such as location and temperature (i.e. low temperature for direct use, moderate/high temperature for electricity generation, etc.). The web portal is user-friendly and flexible, allowing data to also be retrieved for specific geological, geophysical, environmental and/or other purposes related to assessing and identifying geothermal potential.

Data is stored in standard data measurement units (SI units) and documented to ensure quality and validation. Verification of the data is completed throughout the various phases of the mapping project.

Data Sources and Description

The data underpinning the Geothermal Resource Estimate Maps of Yukon was obtained from both private and public sources. Data types varied between raw data in text and excel file format to shape files for import into Geographic Information Systems.

Base Map Data

The base map data is made up of several topographic themes containing natural resource and land management information. These layers form the core of the Resource Estimate Maps and are the base from which all of the maps are created.

NTS (National Topographic System) Grid

Mapping for this project was done using the NTS (National Topographic System) grid. This grid is a departure from the size recommended by the Global Protocol. It was

Canadian Geothermal Energy Association
PO Box 1462 Station M, Calgary, Alberta, T2P 2L6, Canada
info@cangea.ca - www.cangea.ca



chosen because it is a nation-wide standard that is recognized and used across many different industries in Canada, and will be used to map all of the provinces and territories of the country.

The NTS grid is a standard geographic numbering system that identifies topographic map coverage for all of Canada. The nation is divided into primary quadrangles of 4° of latitude and 8° of longitude. Each of these quadrangles is further broken down into 16 letter blocks (A-P) of 1° of latitude and 2° of longitude. The 1:50,000 (50 k) grid divides these letter blocks into 16 more cells (numbered 1-16), of size 15' latitude by 30' longitude. Each individual grid cell varies in size with an average area of 7.2×10^8 m² (24 x 27km). This grid system abruptly changes above the 68th parallel where the NTS grids are doubled in area and merged across lines of longitude as they converge towards the pole. Some of the well data drilled along the northern coast intersects two of these NTS grid cells and were preserved to maintain consistency with the NTS grid system used throughout the rest of the territory. Using this grid system, the territory of the Yukon was divided up into 731 individual grid cells, which provided the surface grid framework for estimating the geothermal potential of the Yukon.

Using the grid system, the local thermal structure is estimated for each of the grid cells using a 1D heat conduction model, and then the total potential in the region is estimated by summing together the discrete estimates of each cell.

This grid system was obtained from the Yukon Geological Survey's- Geo-Data Downloads website.

Given the small number of wells with bottom hole temperature data (64) the NTS system showed a mapped data coverage of 4.9% of the territory. The resource estimates are summarized in the table below.

Technical Potential for Geothermal in Yukon			
NTS Grid Version			
Values Indicate Potential Power (Indicated and Inferred Resources)			
Recovery	Depth	Generation Potential	
		Indicated Resources	Inferred Resources
5%	1,500m:	92 MW	0 MW
	2,500m:	542 MW	716 MW
	3,500m:	724 MW	1,665 MW
	4,500m:	424 MW	2,544 MW
	Total:	1,782 MW	4,926 MW
14%	1,500m:	258 MW	0 MW
	2,500m:	1,517 MW	2,006 MW
	3,500m:	2,027 MW	4,663 MW
	4,500m:	1,186 MW	7,124 MW
	Total:	4,989 MW	13,793 MW
20%	1,500m:	369 MW	0 MW
	2,500m:	2,167 MW	2,865 MW
	3,500m:	2,896 MW	6,661 MW
	4,500m:	1,695 MW	10,177 MW
	Total:	7,127 MW	19,704 MW
Installed Generation Capacity (All Sources):			0 MW

Table 6: Technical potential, NTS grid version

As an example of what the subsurface temperature data coverage in the Yukon looks like, the figure below is a map showing all of the bottom hole temperature data points that were collected.

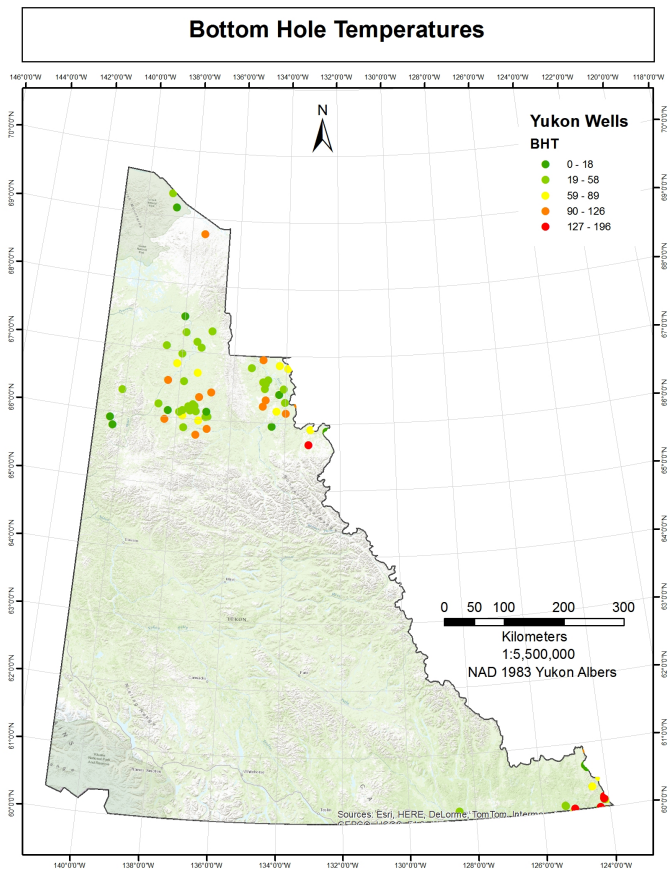

Figure 17: Bottom hole temperatures, Yukon

National Parks, Provincial (Territorial) Parks, and assorted Protected Areas

This data was collected from the NRCan website and included national and territorial park boundaries, wildlife areas and sanctuaries, ecological reserves, wilderness preserves and special management areas. More specific information related to each administrative boundary can be found in the Entity and Attribute section.

Territorial Boundary

Compiled by NRCan, the Yukon Boundary polygon layer contains the polygon that represents the location of the boundaries of the Yukon.

Aboriginal Lands

The Aboriginal Lands product consists of polygon entities that depict the administrative boundaries (extent) of lands where the title has been vested in specific Aboriginal Groups of Canada or lands that were set aside for their exclusive benefit. Please note that this data set is not to be used for defining boundaries. Administrative decisions should be based on legal documents and legal survey plans. More information on the individual Indian Reserves, Settlement Lands and Indian Lands contained in the Aboriginal Lands Dataset can be found at the following web site: <http://www.clss.nrcan.gc.ca> and ftp://ftp.geomaticsyukon.ca/GeoYukon/First_Nations/

Transmission Grid

The transmission line map for the Yukon was obtained from the Yukon Energy Corporation. The transmission lines represent the bulk and regional transmission lines that provide power to the territory through lines of varying capacity.

Bottom Hole Temperature and Heat Flow Data

The subsurface temperature data is comprised of measurements from oil and gas wells that were obtained from the Government of Yukon website (ftp://ftp.geomaticsyukon.ca/GeoYukon/Oil_and_Gas/) and from third party sources including Accumap

Borehole data was also obtained from boreholes catalogued in the Canadian Geothermal Data Compilation⁷⁴. The compilation contains the measured data of the Geothermal Group of the Earth Physics Branch from 1962 to 1986, data acquired by the Geological Survey from 1986 to present, and data from universities and contractors. The data was collected from wells and boreholes at 1,958 sites throughout Canada and include temperature, thermal conductivity, heat generation, petrologic descriptions, and information on which to base corrections for inclination of the well and glacial history.

Heat flow data was obtained from borehole data from the North American Borehole (NABH) dataset from the University of Michigan's Global Database hosted on NOAA's National Climatic Data Centre.⁷⁵

Surface Temperature

Surface temperature measurements used for the Yukon were a compilation of data obtained from Environment Canada.

The 'Second Generation of Homogenized Temperature' datasets from Environment Canada were prepared to provide a spatial and temporal representation of the climate trends in Canada. Non-climatic shifts were identified in the annual means of the daily maximum and minimum temperatures using a technique based on regression models. Datasets were provided for 338 locations across the country. Observations from nearby stations were sometimes combined to create long time series. Data series were extended to cover the period 1895-2008 as much as possible.

Sediment Thickness

Data for sediment thickness in the Yukon is quite sparse and as a result, the thickness of the sediment package that overlies either pre-Cambrian basement rock, or metamorphic/igneous crystalline rock – from now on referred to as “depth to basement” - was estimated by calculating isopachs for major time divisions represented in the bedrock geology coverage, thickness values of which were compiled from two datasets:

- Sediment thickness of each major time division gathered from reclassified formation top intersections in oil and gas well data set.
- Sediment thickness estimates of sediment outcrop from literature compiled and reclassified to reflect approximate major time divisions (Abbot, Gordey, Gordey et al, and Norris).

Isopachs for each major time division were gridded using global krigging estimates and then masked out using polygons derived from exposed sediments that were older than the time division in question. These masked regions were essentially an efficient proxy to a mapped erosional boundary of the isopach being calculated.

The Whitehorse Trough sediment thickness was estimated using a broad contoured interpretation from literature (White et al) to estimate the large scale thickness changes across the basin where sediments were interpreted to be thicker towards the north western side of the trough.

All thickness estimates are meant to be broad interpretations only in order to facilitate the heat calculations. Further refinement of basin sediment thickness is recommended, although any thicknesses that are greater than 5,000m will not affect the results as no heat model calculations were done below this depth.

The figure below shows a series of images illustrating how the above datasets were used in combination to estimate the thickness of the sedimentary cover across the territory.

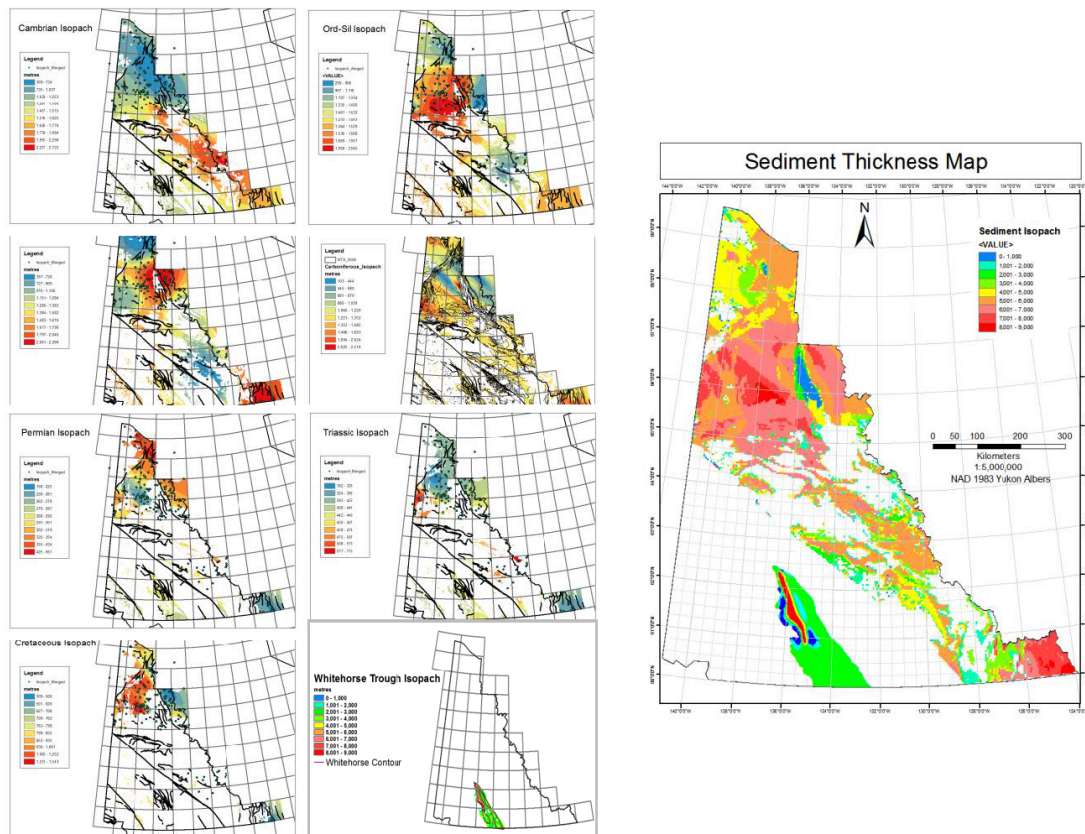

Figure 18: Series of images illustrating how datasets were used in combination to estimate the thickness of the sedimentary cover

Thermal Properties

Default values of thermal conductivity, heat production rate, density and heat capacity of sediments and basement rocks were applied as recommended by the Global Protocol.

Yukon Resource Estimate Maps

All calculations closely followed the Global Protocol published in the Proceedings of the Geothermal Resources Council Annual Meeting 2010.⁷⁶

The Global Protocol states that a fundamental assumption in this process is that pure vertical conduction is the dominant mechanism of heat transfer through the crust, and thus calculations done assume a 1D heat conduction model. However, besides the north-eastern half of the territory that is divided by the Tintina Fault system, the geology throughout the southwestern half of the Yukon is complex and metamorphic, igneous, or volcanic in nature where it could not be proven that conduction is the dominant heat transfer mechanism, based on available data. After discussing the issue with the international community, it was determined that though other areas with similar geology (e.g., the Cascades region in the United States) are experiencing a similar challenge, there does not currently exist any modifications to the Protocol that account for geologic regions such as those likely to be found in the Yukon where heat transport might occur by other means, such as fluids moving along fractures and fault zones. In the absence of an alternative, the original assumptions from the protocol were used and implemented for the calculations performed.

As stated earlier, the Yukon is split into two main areas by the northwest trending Tintina fault zone. North and east of this prominent physiographic feature, sediments of various depositional periods (pre-Cambrian to Cretaceous and Palaeogene) are preserved and represent accumulation of sediment along the ancient, northwestern edge of the North American Continent and ancient inland sea. The southeastern tip of the Yukon similarly represents the tip of a thick wedge of the northwestern portion of the Western Canada Sedimentary Basin (WCSB). Any rock formations deposited or formed earlier than Cambrian time, was assumed to be crystalline in nature and classified as “basement” rock. South and west of the Tintina fault, most of the rocks are volcanic, metamorphic, or

plutonic in origin, with the exception of the Whitehorse Trough - a wedge of sediment representing a period of deposition that occurred in the Mesozoic in an inland sea depositional environment – similar to the Bowser basin in BC

Most of the underlying Lower Proterozoic sedimentary and metamorphic/volcanic/igneous rock complexes have lost permeability by being metamorphosed to a high grade state and are therefore also considered “basement” rock for the purposes of geothermal conductivity. For both Alberta and BC to the south, a large portion of the WCSB was key to the production of the resource maps generated for these provinces, where heat was assumed to be under transport only by conduction. The same assumptions also went into the production of the Yukon maps for rock that was clearly sedimentary in origin and relatively undisturbed (i.e. not significantly altered), and where the heat flow in the sedimentary column is assumed to be vertical and uniform:

- if there are no significant proximal lateral variations in the thermal conductivity of the rocks (as is assumed to be the case within the Western Canada Sedimentary Basin),
- if the rate and volume of groundwater flow is negligible (an assumption still the object of debate), and
- if heat generation with the sediment is negligible (see below).

Given these assumptions, the vertical temperature profile and variation of the geothermal gradient are determined by the heat flow at the base of the sedimentary column and by the thermal conductivity of the rocks.)

Methods - Quality Assurance/Quality Control

For the Yukon Resource Estimate Maps, the initial set of temperature at depth data was provided absent any Quality Assurance/Quality Control (QA/QC) review.

Reviewing each data point individually was doable, given the small number of valid bottom hole temperatures recorded. A ‘filtering’ process was used to exclude anomalous data points and remain consistent.

The process is as described below:

1. The data was grouped into depth 'bins' corresponding to the various depths at which maps are produced.
2. Within each bin, an aggregate predictive trend was identified, based on the totality of the data.
3. Actual temperature measurements at depth were compared to the predicted values and the differences identified.
4. Those points, where the difference exceeded 2 standard deviations, were excluded from the set of data ultimately mapped, being identified as anomalous. This does not mean that they are invalid, rather that the QA/QC work necessary to confirm them is beyond the scope of this initiative.
5. Maps were developed based on the data, which was within 2 standard deviations of the depth-specific trend.

The following figure is a plot of the temperature with depth, showing 3 of the 67 available bottom hole temperatures available falling outside the standard deviation of 2 from the global trend. The 'North' subset of wells indicates wells drilled in the Northern Yukon Fold Complex (Peel Plateau and Eagle Plain) and a few along the Arctic Margin Basin. The 'South' subset of wells represents wells in the Western Canadian Sedimentary Basin (Liard Basin.)

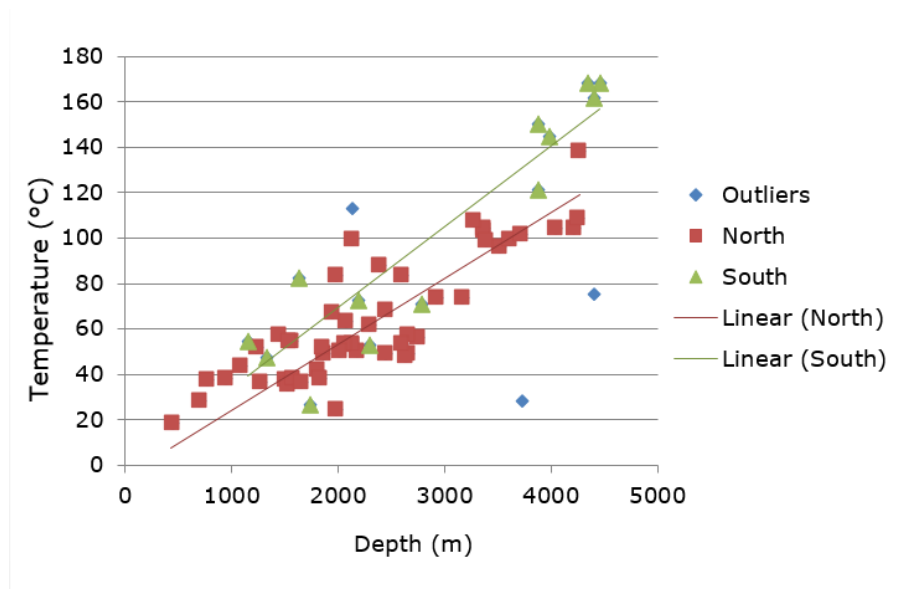

Figure 19: Temperature vs. depth profile of selected boreholes.

Methods - Temperature Profile

The first step in following the Global Protocol was to estimate and model the temperature profile, heat flow and available heat of the Earth's crust down to a 5,000 metre depth. No measurements below the 4,000 to 5,000 metre interval were recorded so no attempt was made to interpolate values below 5,000m.

- a) Build a Geographic Information Systems (GIS) database and split the Yukon into both NTS grid cells and 5'x5' grid cells with rock property and geological attributes. This divided the Yukon into individual surface cells, with each cell representing a column from the surface to a depth of 5,000 m in 1,000 m intervals.
- b) Create a sediment thickness (depth to basement) map.
- c) Populate sediment thermal properties: thermal conductivity (KS) and heat generation of sediment (AS).

Default properties given in the Global Protocol were used for these values.

- $K_S = 2.50 \text{ W/mK}$,
- $A_S = 1.00 \mu\text{W/m}^3$

d) Populate basement thermal properties: thermal conductivity (K_B) and heat generation of basement rocks (A_B).

Default properties given in the Global Protocol were used for these values.

- $K_B = 3.45 \text{ W/mK}$,
- $A_S = 2.65 \mu\text{W/m}^3$

For each 3D grid block crossing the sediment–basement contact, these values were calculated as the volume-weighted average of values for sediment and basement components.

- e) Create surface temperature map using mean average annual surface air temperature.
- f) Create surface heat flow map.

For grid cells in which borehole temperature data was available, the surface heat flow was calculated from the product of the average thermal gradient to the deepest temperature data and the thermal conductivity of the sediment, minus half the heat generated within the sediment.

g) Derive temperature and heat flow at sediment-basement interface for $S < 4,000$ m and $S > 4,000$ m, where S is the depth to the sediment-basement interface.

The methods and equations as given in the Global Protocol were employed to complete this step.

h) Derive T at depth X , down to 5,000 m depth, where X is the midpoint between 1,000 m intervals.

The methods and equations as given in the Global Protocol were employed to complete this step. Note that the Global Protocol recommends calculating temperature to 10,000 m for Theoretical Potential and 6,500 m for Technical Potential. The Geothermal Resource Estimate Maps of the Yukon, however, present both of these to 5,000 m to reflect current realistic (economic) drilling capabilities.

Methods - Theoretical Potential

The next step involves estimating the Theoretical Potential of geothermal power in the crust down to a depth of 5,000 m. As noted above, this is a departure from the Global Protocol, which recommends estimating Theoretical Potential to 10,000 m.

- a) Derive average temperature for each 1,000 m depth interval. Approximate by calculating temperature at mid-point of each interval.

The methods and equations as given in the Global Protocol were employed to complete this step.

- b) Assign density (ρ) and specific heat capacity (C_p) of interval.

The methods and equations as given in the Global Protocol were employed to complete this step.

- c) Derive volume of each grid cell (V_c). Note that volume varies slightly with latitude as the distance between lines of latitude change as you move north and south. Thus the surface area, and hence the volume of each 3D grid cell, varies slightly with latitude.

- d) Calculate available heat for each depth interval in each cell (H).

The methods and equations as given in the Global Protocol were employed to complete this step.

- e) Derive theoretical potential power (P).

The methods and equations as given in the Global Protocol were employed to complete this step.

Please note that the power estimated is a reflection of the data available at each depth. As such, a decrease in power with increasing depth may be observed and is likely indicative of limited data availability more so than an actual decrease of potential power.

Methods - Technical Potential

The final step was to estimate the Technical Potential of geothermal power in the crust down to a depth of 5,000 m. As noted above, this is a departure from the Global Protocol, which recommends estimating Technical Potential to 6,500 m.

Technical Potential is defined by the Global Protocol as “Theoretical Potential that can be extracted after consideration of currently ‘insurmountable’ technical limitations”. Technical Potential provides a more realistic estimate of geothermal power potential using current technology, and considering access restrictions.

For the Technical Potential estimate, it was assumed that all grid blocks containing primary data are accessible for geothermal production, as availability of down hole temperature measurements demonstrates that the location has previously been accessed for exploration. The Technical Potential was estimated for low, medium and high recoverability factor (R) for the rock of 0.05, 0.14 and 0.20, respectively. Note that the ‘low’ value is a departure from the Global Protocol, which recommends a minimum R = 0.02.

Also note that while First Nations and National/Territorial Parks are protected, given the potential for geothermal to provide clean energy to northern and remote communities and reduce greenhouse gas emissions, these lands are recognized but not excluded

Canadian Geothermal Energy Association
PO Box 1462 Station M, Calgary, Alberta, T2P 2L6, Canada
info@cangea.ca - www.cangea.ca



from the assessment. Some National Parks and protected areas already have geothermal and other renewable developments and/or policies within their jurisdictions. Please note that the power estimated is a reflection of the data available at each depth. As such, a decrease in power with increasing depth may be observed and is likely indicative of limited data availability more so than an actual decrease of potential power.

Methods – Primary Geothermal Exploration Areas

Although not required by the Global Protocol, this mapping project also provides a high level delineation of geothermal exploration areas. These regions, outlined in the figure below, summarize the cumulative association of key geological factors and the geothermal exploration results derived herein. Further classification of these potential exploration regions of moderate favourability into areas of high favourability was delineated from a probabilistic analysis of all input layers. Further detailed work is recommended to refine these results by region.

Primary Geothermal Exploration Areas

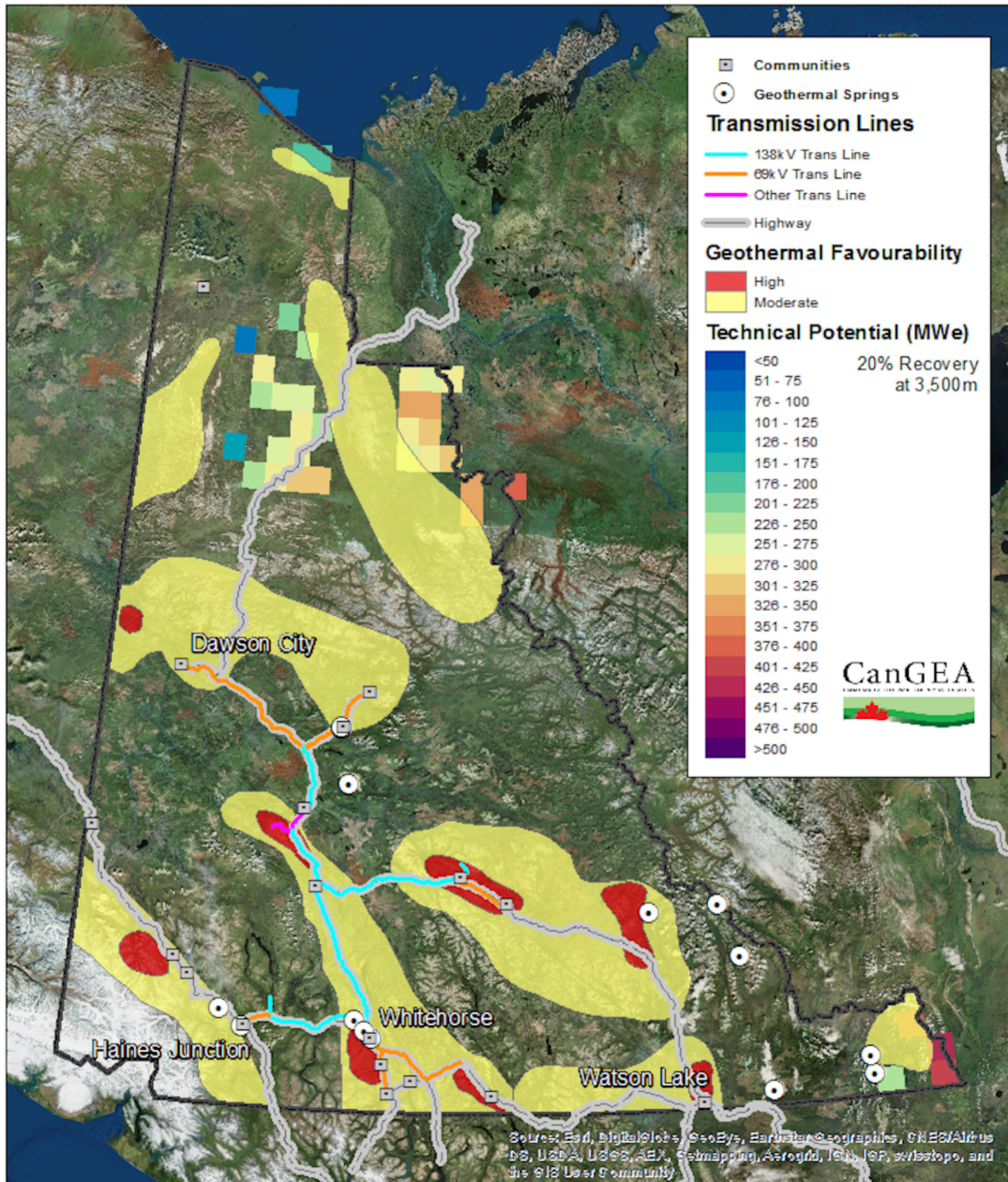

Figure 20: Primary geothermal exploration areas

Methods - KML Formatting

The Global Protocol recommends that results be presented using common visualization and data architecture in accordance with previous geothermal potential maps, such as that produced for the United States in 2011.

- a) The Geothermal Resource Estimate Maps of the Yukon were created using GIS software. All files contained in the geodatabase have been converted to KML format for visualization in Google Earth and presented in a format equivalent to that of the USA geothermal potential maps.

- b) Layers for both the NTS and 5'x5' grid versions include the following:
 - Estimated temperature at depth for Power Generation at 1 km intervals from 1,500 m to 4,500 m
 - Estimated temperature at depth for Direct Use purposes at 500 m and 750 m
 - Grid blocks showing Theoretical Potential to 5 km
 - Grid blocks showing Technical Potential to 5 km
 - Level of confidence as either an Inferred or Indicated Resource, according to the Reporting Code
 - Grid blocks showing geothermal gradient to 5 km
 - Estimated depth to basement
 - Grid blocks showing estimated conductivity to 5 km
 - Grid blocks showing heat generation to 5 km
 - Estimated heat flow at surface
 - Geothermal favourability rating
 - Land use including excluded zones, transmission lines/grid access and other major topographic/geological features

- c) Layers are available on the established CNGD (Canadian National Geothermal Database) web portal as packages of downloadable KMZ files. The public will be able to view these files using the publicly available Google Earth program.

Summary Tables and Charts of Geothermal Potential

The value of Theoretical Potential depends on available geophysical data, while the derived Technical Potential is based on the current state of heat recovery and power conversion technology. As all of these will change over time, assumptions such as available heat, depth limits, recovery factor and net thermal efficiency will adjust, changing Theoretical and Technical estimates. Following the Global Protocol, we assumed that conduction is the dominant heat transfer mechanism and that thermal conductivity of sediment deeper than 4,000 m is the same as the basement. Where local data was not available, estimations and calculations relied on the algorithms and global means provided by the Global Protocol.

The tables and charts of estimates of geothermal potential and the data that underpin them are stored in GIS databases available through the CNGD web portal, a user-friendly interface for convenient access by all interested parties. These tables and charts include the following:

- a) Temperature at depth data
- b) Theoretical Potential estimates
- c) Technical Potential estimates
- d) Confidence data (in accordance with the Canadian Geothermal Code for Public Reporting)

Compliance with the Global Protocol and Reporting Code

This part of the report and the data and calculations underpinning the Geothermal Resource Estimate Maps of the Yukon was prepared and endorsed by Dr. Graeme Beardsmore of Hot Dry Rocks Pty Ltd (Australia) as a “Competent Person”, considered to be a “Qualified Person” under the Reporting Code. The Global Protocol respects the Reporting Code’s underlying principles of ‘transparency’, ‘materiality’, and ‘competence’, and this project honours those principles by providing public access to all the underlying data, metadata, charts and tables used in the assessment of the Yukon’s geothermal resources.

Canadian Geothermal Code for Public Reporting

The Geothermal Resource Estimate Maps of the Yukon include estimates of geothermal potential that could be categorized according to the terminology of the Australian and Canadian Geothermal Codes for Public Reporting.

The “Canadian Geothermal Code for Public Reporting” is designed to provide a level of consistency and transparency for the reporting of “Exploration Results”, “Geothermal Resources” and “Geothermal Reserves”. The primary data underpinning the Yukon maps are borehole temperatures, recorded within actual penetrations of the subsurface. The estimates of potential can therefore be classified as Resources rather than Exploration Results. “Indicated Resources” is used to classify estimates based directly on actual measured temperature data within a 3D grid cell, while “Inferred Resources” is used for estimates based on values extrapolated from actual bottom hole temperature measurements. None of the geothermal potential reported in the Geothermal Resource Estimate Maps of the Yukon can be classified as “Measured Resources” because fluid flow capacity has not currently been determined from any real data. Further analysis of individual well data would be required to determine if there could be an increase in confidence level to Measured Resources for any of the results.

Data Limitations and Implications

The Yukon geothermal resource evaluation revealed a number of key findings and limitations of the available data. Key items are summarized below.

- Large areas of the Yukon were not available for incorporation into this study due to the lack of sufficient data across much of the Territory.
- While the reported resource estimates are substantial, the estimates are dominantly based on potential resources in the north-eastern half and southeastern tip of the Yukon only, due to the data density from the oil and gas wells drilled in the Peel Plateau, Mackenzie Delta, and the Liard Basin.
- The Global Protocol is not suitable for incorporating data within volcanic and crystalline rock terrain. Therefore, areas that have been indicative of high

potential for geothermal development, based on geological setting and previous evaluations, are not adequately reflected within this mapping study.

- Further evaluation of the oil and gas industry data would likely serve to increase the confidence in the resource estimates for the Yukon. Significant water production data exists within the industry. This could be combined with relevant thermal data to produce a “Measured” estimate of the geothermal potential of specific reservoirs, according to the Canada Geothermal Code for Public Reporting.
- There may be other industry information that would serve to increase the data coverage and add to the estimates for geothermal potential in the Yukon if it were made available or collected during future work, such as within the mineral exploration or water well drilling industries. This would also include estimates of sediment thickness over basement and/or metamorphic/igneous crystalline rock.

The overall result of these limitations is a significant underestimation of the geothermal resource potential in the Yukon, in our opinion.

Canadian National Geothermal Database

In conjunction with the Geothermal Resource Estimate Maps of Alberta and British Columbia, a web portal has been established to host a publicly accessible Canadian National Geothermal Database (CNGD). The favourability maps and database will not only be used to investigate areas in Canada with high geothermal anomalies but also identify regions of little or no data available to promote further data collection and research.

The CNGD initiative is in line with the goals of the global geothermal industry, which are to:

- Improve accessibility of information and knowledge as a risk mitigating effort in geothermal
- Reduce fragmentation of data collection and avoid duplication of efforts

Canadian Geothermal Energy Association
PO Box 1462 Station M, Calgary, Alberta, T2P 2L6, Canada
info@cangea.ca - www.cangea.ca



- Increase reliability of available data
- Increase awareness of geothermal energy potential and utilization

The format of the web portal is designed to be user-friendly and flexible, allowing data to be retrieved as multiple different file types, including detailed spreadsheets and Google Earth maps and data. These files contain specific geological, geophysical, environmental and/or other criteria useful in assessing and identifying geothermal resource potential.

Similar to the U.S. National Geothermal Database, the CNGD stores critical geothermal site attribute information including: temperature at depth, thermal conductivity, heat flow, well logs, bottom hole temperatures (BHT), drill stem test (DST), permafrost data, seismicity/microseismicity, porosity/permeability data, water chemistry, and geophysical surveys. It will also be inclusive of all types of geothermal resources such as direct-use, hydrothermal, petrothermal, hot sedimentary aquifer, geopressured, geothermal fluids co-produced with oil and/or gas, and others including those that may be accessible using Enhanced Geothermal Systems (EGS) techniques. Data sources include historical data and existing geothermal resource assessment data already compiled by universities, research organizations, as well as private and publically funded geothermal exploration projects.

The database can also be used to identify regions of Canada that lack the required data for assessing geothermal potential so that priority exploration research areas can be established. The CNGD and maps provide a level of resource estimate confidence consistent with geothermal reporting codes. The maps also feature land use information aimed at increasing identification of favourable areas. Subsurface favourability maps have also been considered. It has been made available to the public and will serve as a geothermal exploration tool for making informed business decisions, as well as a means for mitigating investment risks. The database was established and is hosted by CanGEOA.

Temperature at Depth Maps

The temperature at depth maps are a valuable resource when estimating the application possibilities for the communities in the Yukon. The following maps represent

Canadian Geothermal Energy Association
PO Box 1462 Station M, Calgary, Alberta, T2P 2L6, Canada
info@cangea.ca - www.cangea.ca



temperatures at specific depths that have been measured or calculated. The maps that have been created show temperature contours that are the average temperature over the 1,000 m interval, centred at the map depth. This chapter also includes temperature maps that are targeted at displaying information that is relevant for direct-use applications. These maps represent temperatures at specific depths shallower than 500m that have been measured or calculated. The maps have been created to show temperature contours over 100m intervals. Application possibilities for the different communities are discussed in the appropriate community chapter.

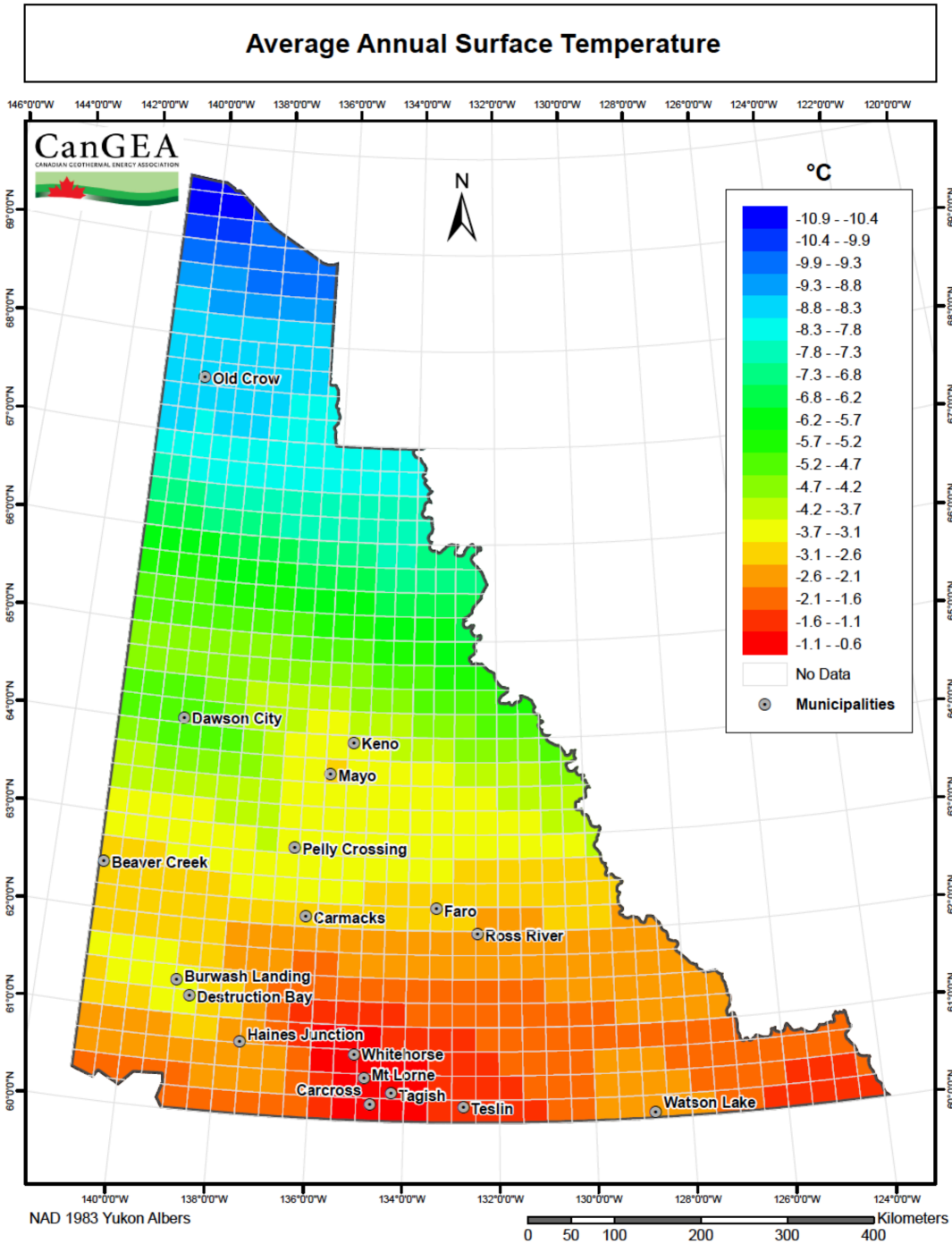

Figure 21: Average annual surface temperature

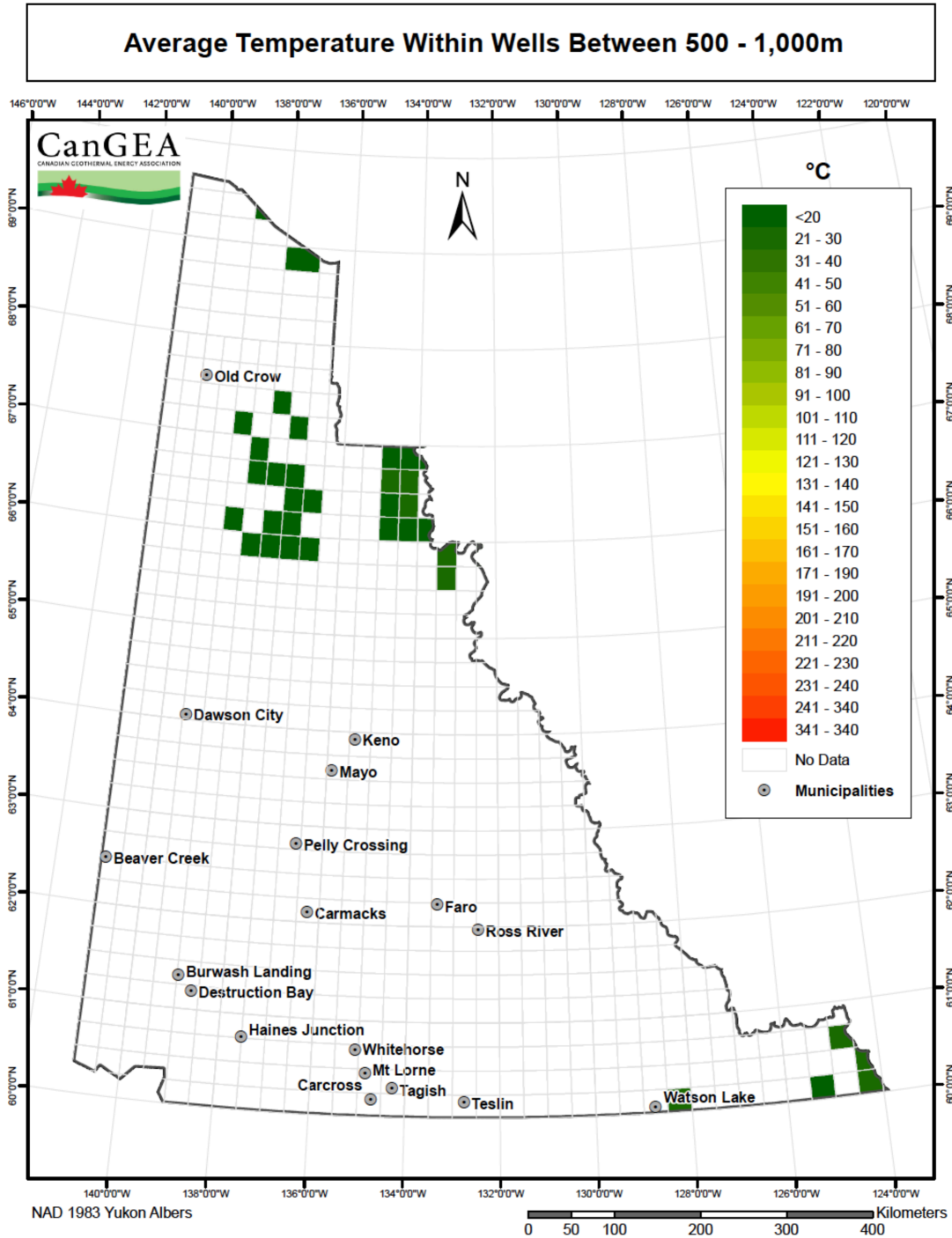

Figure 22: Average temperature within wells – 500m – 1,000m

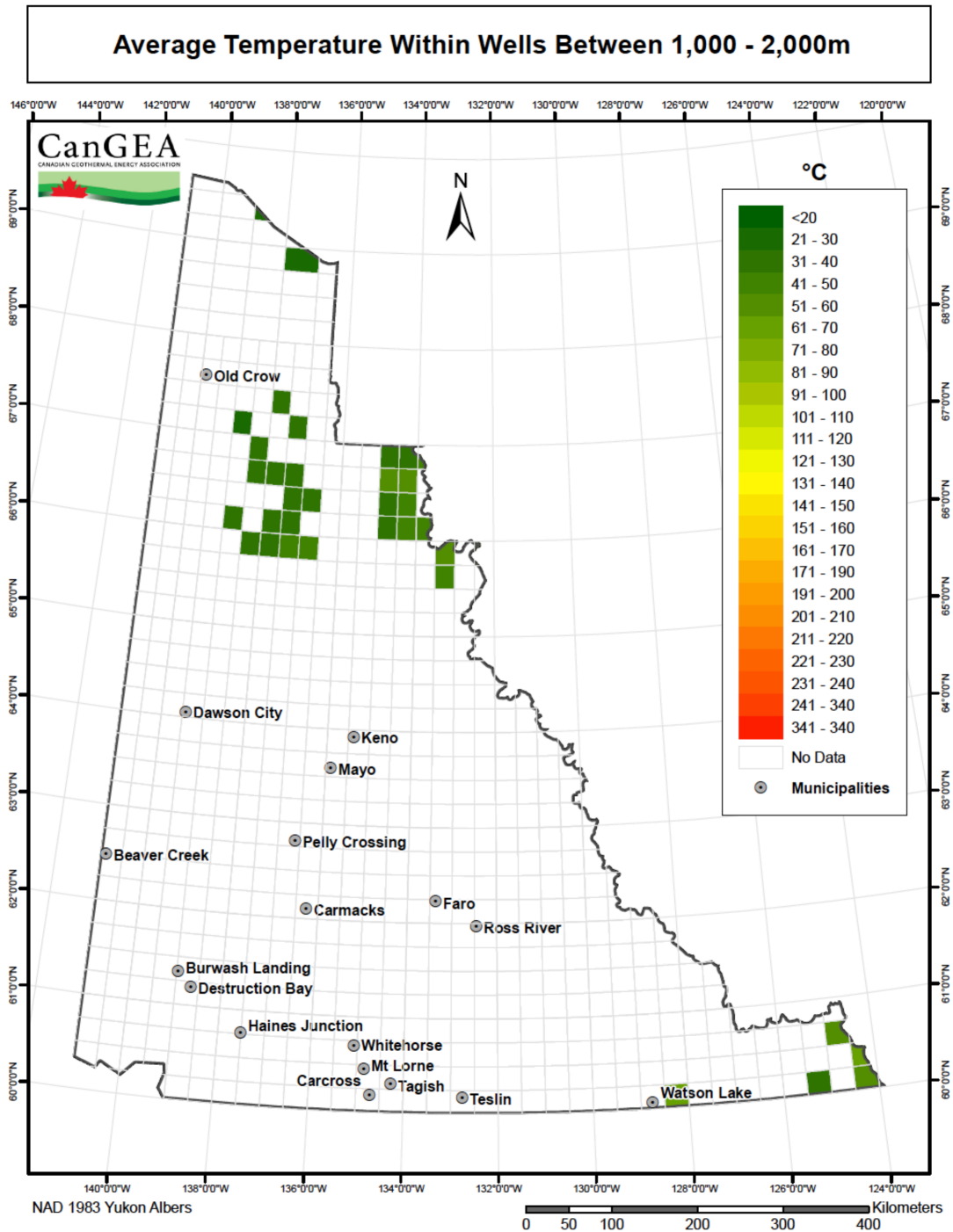

Figure 23: Average temperature within wells – 1,000m – 2,000m

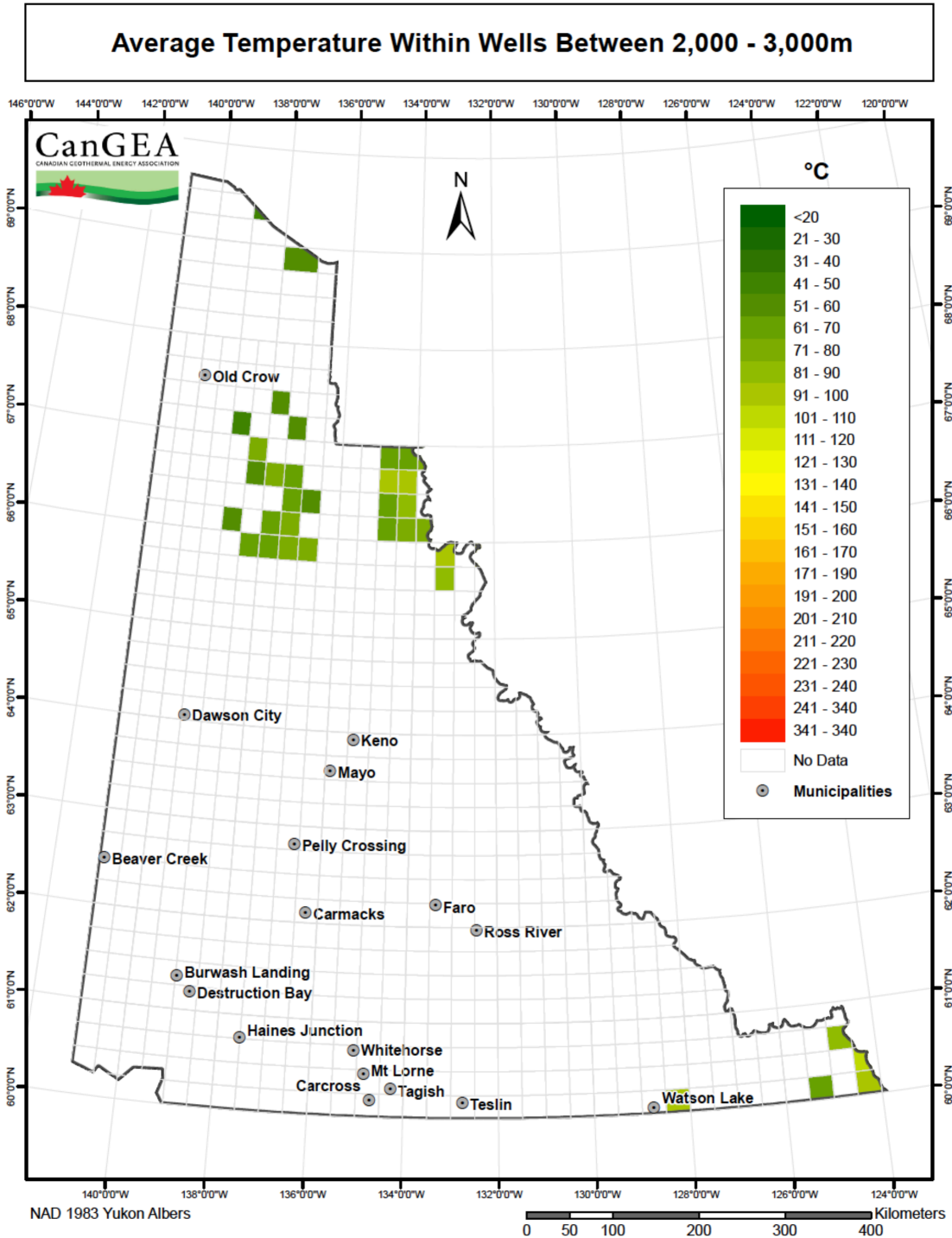

Figure 24: Average temperature within wells – 2,000m – 3,000m

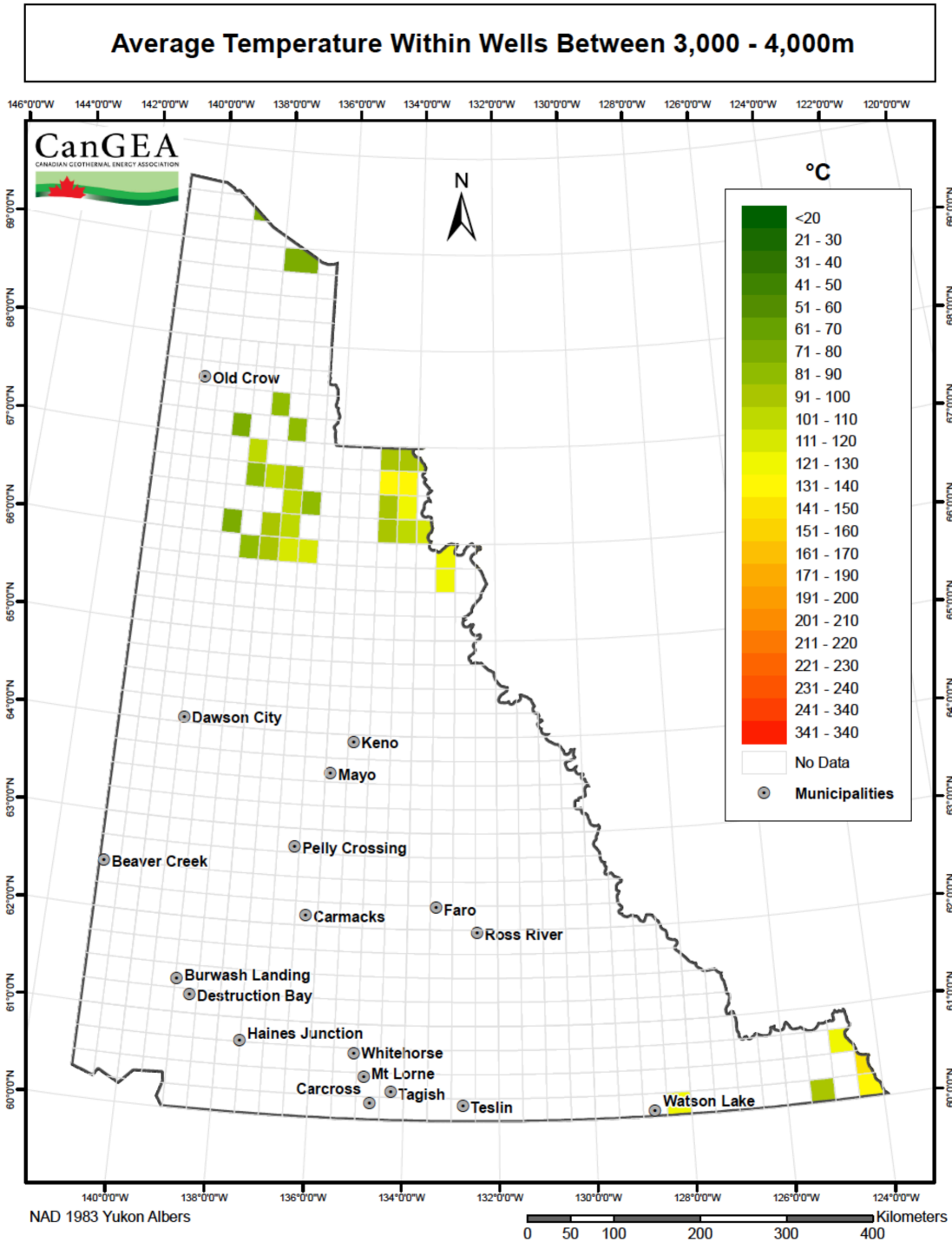

Figure 25: Average temperature within wells – 3,000m – 4,000m

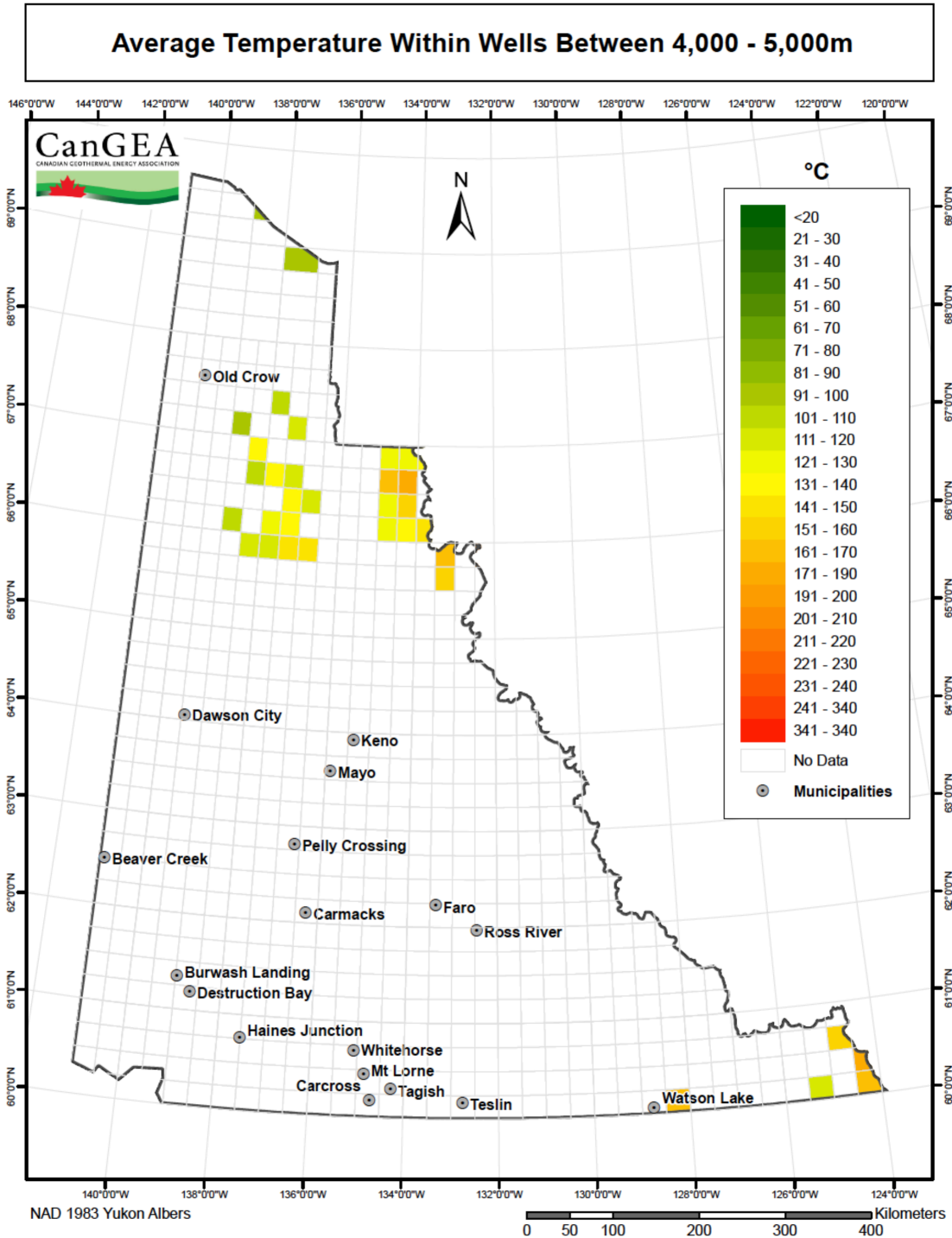

Figure 26: Average temperature within wells – 4,000m – 5,000m

Technical Potential

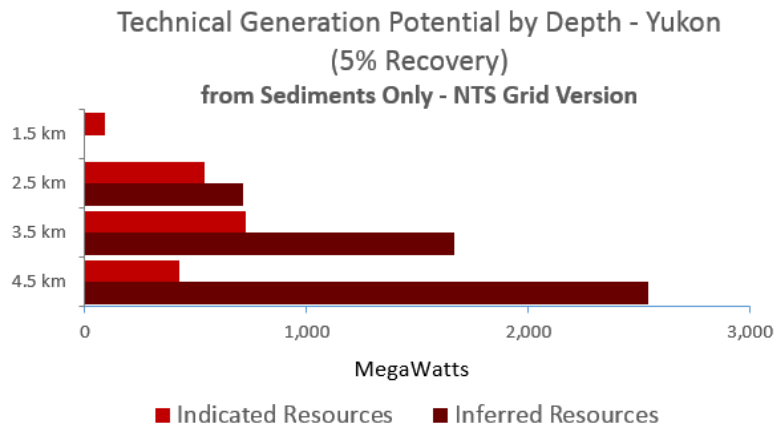

Figure 27: Indicated vs. inferred resources (5% recovery)

Technical Potential for Geothermal in Yukon			
NTS Grid Version			
Values Indicate Potential Power (Indicated and Inferred Resources)			
Recovery	Depth	Generation Potential	
		Indicated Resources	Inferred Resources
5%	1,500m:	92 MW	0 MW
	2,500m:	542 MW	716 MW
	3,500m:	724 MW	1,665 MW
	4,500m:	424 MW	2,544 MW
	Total:	1,782 MW	4,926 MW
14%	1,500m:	258 MW	0 MW
	2,500m:	1,517 MW	2,006 MW
	3,500m:	2,027 MW	4,663 MW
	4,500m:	1,186 MW	7,124 MW
	Total:	4,989 MW	13,793 MW
20%	1,500m:	369 MW	0 MW
	2,500m:	2,167 MW	2,865 MW
	3,500m:	2,896 MW	6,661 MW
	4,500m:	1,695 MW	10,177 MW
	Total:	7,127 MW	19,704 MW
Installed Generation Capacity (All Sources):			0 MW

Figure 28: Technical potential, NTS grid version

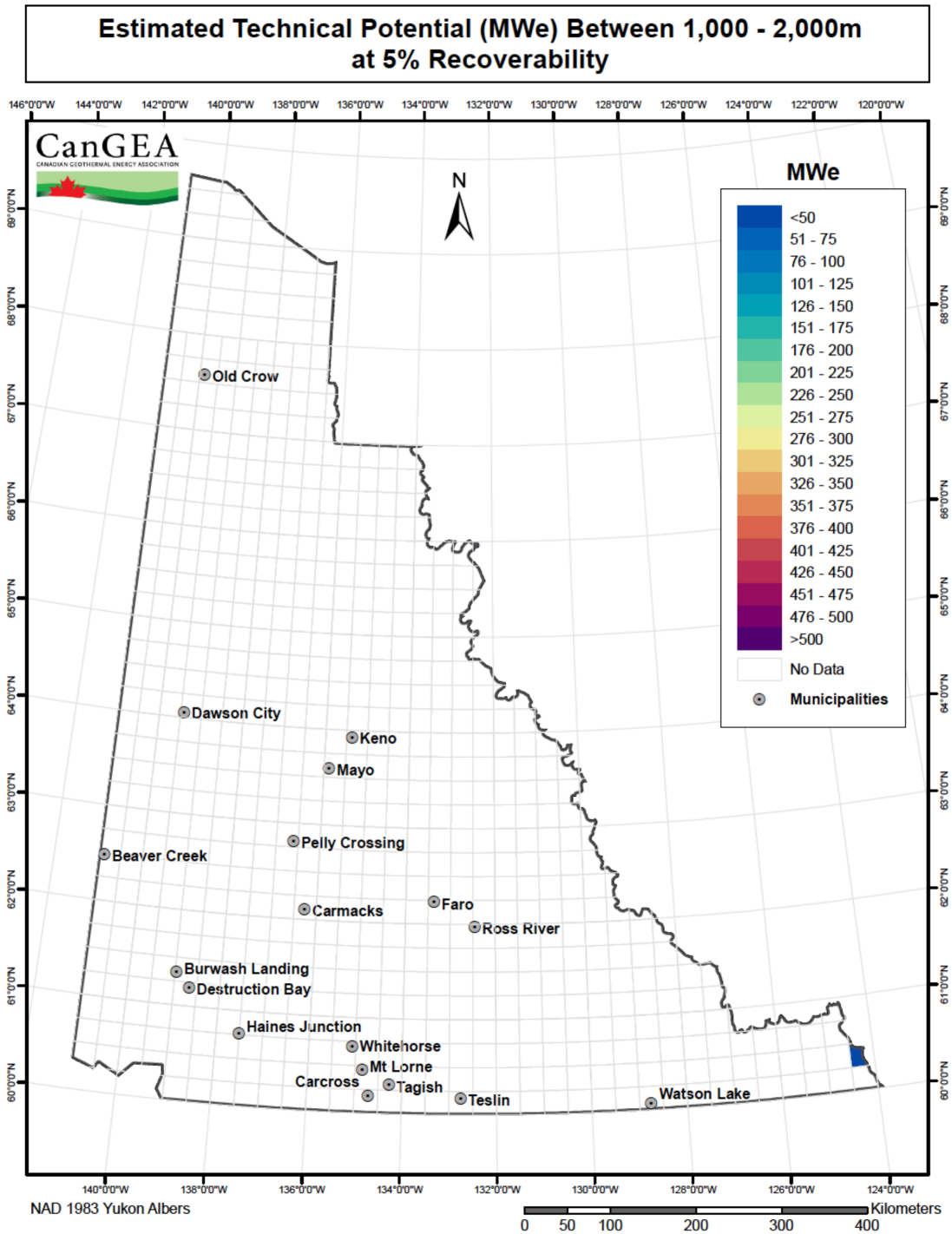

Figure 29: Technical potential between 1,000m and 2,000m at 5% recoverability

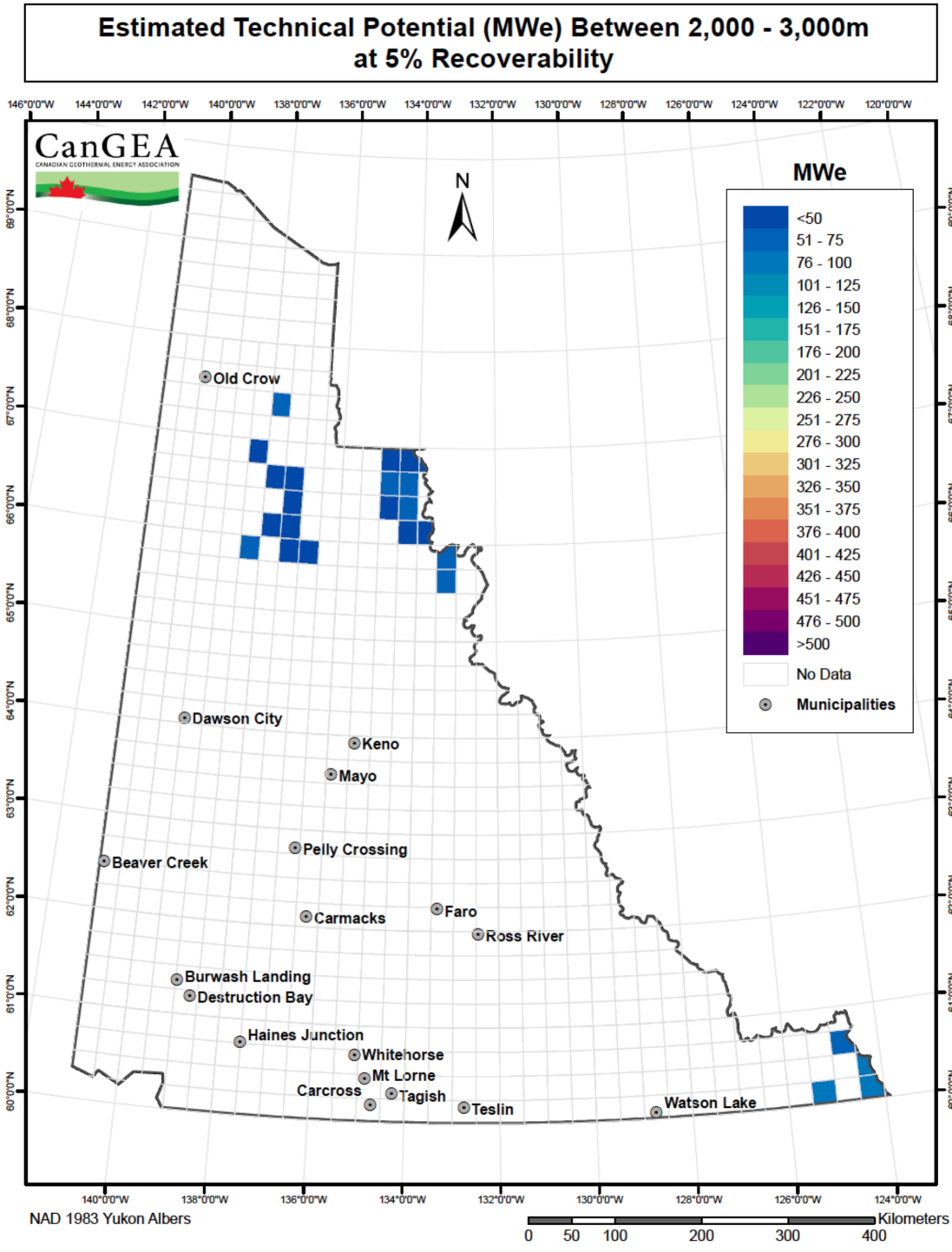

Figure 30: Technical potential between 2,000m and 3,000m at 5% recoverability

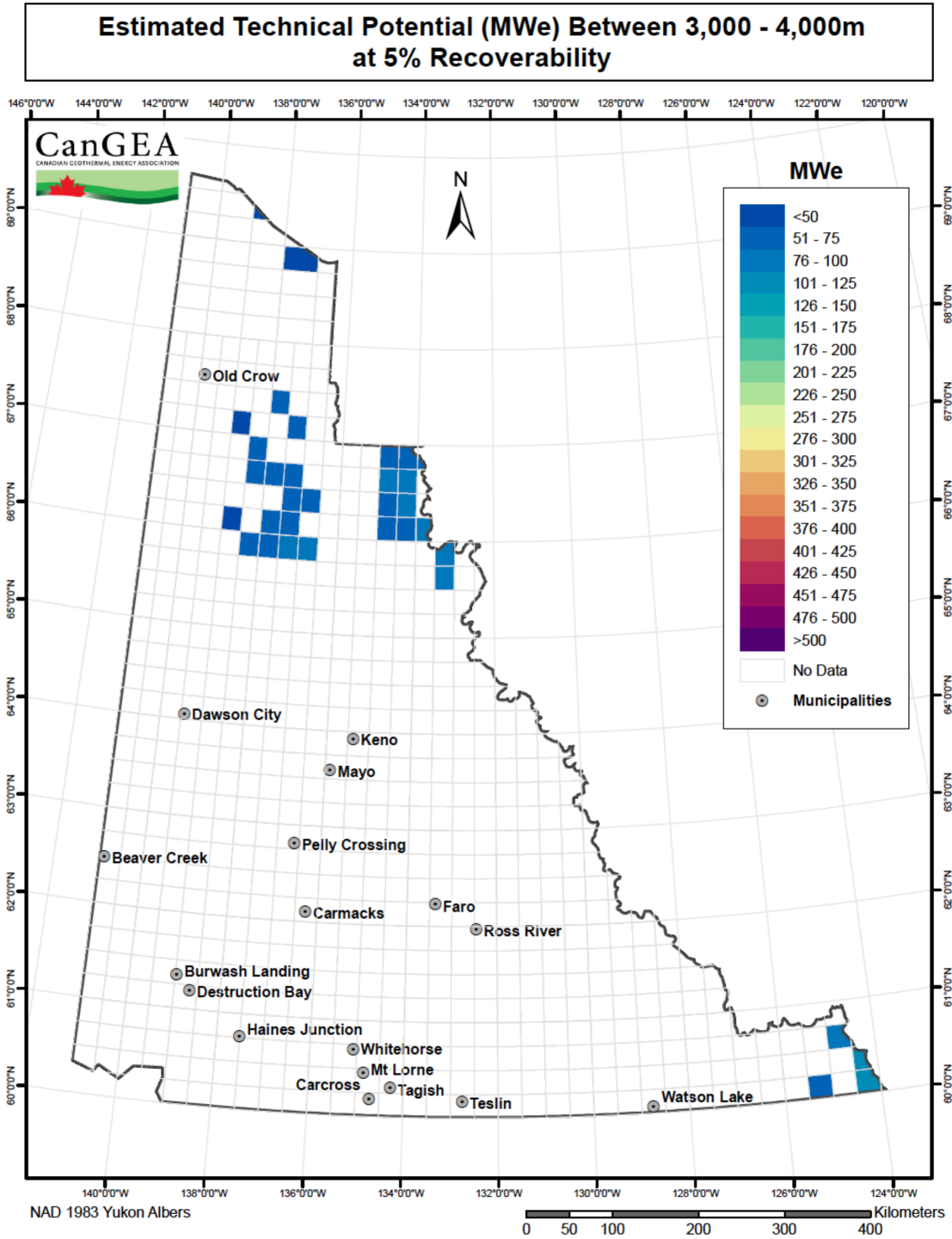

Figure 31: Technical potential between 3,000m and 4,000m at 5% recoverability

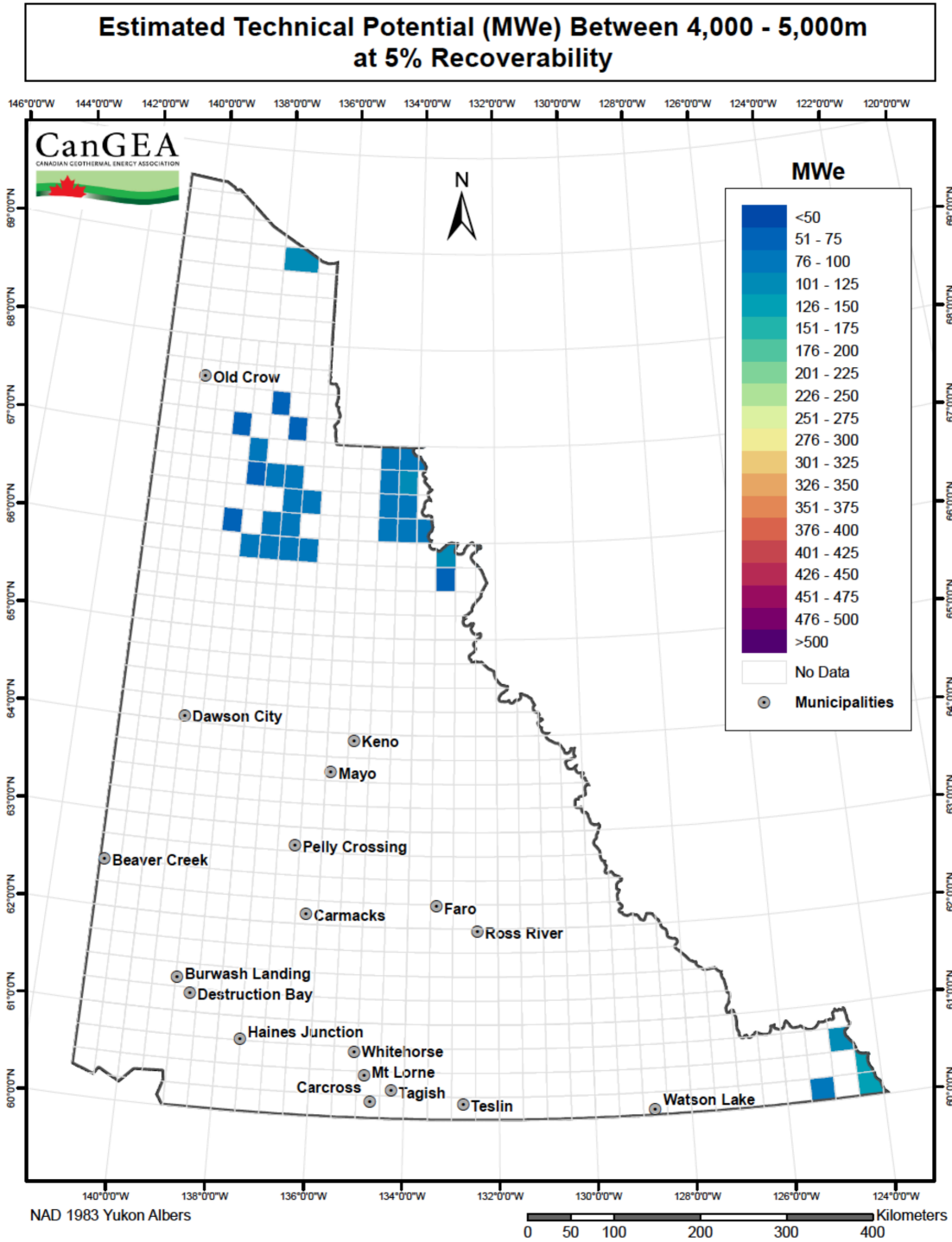

Figure 32: Technical potential between 4,000m and 5,000m at 5% recoverability

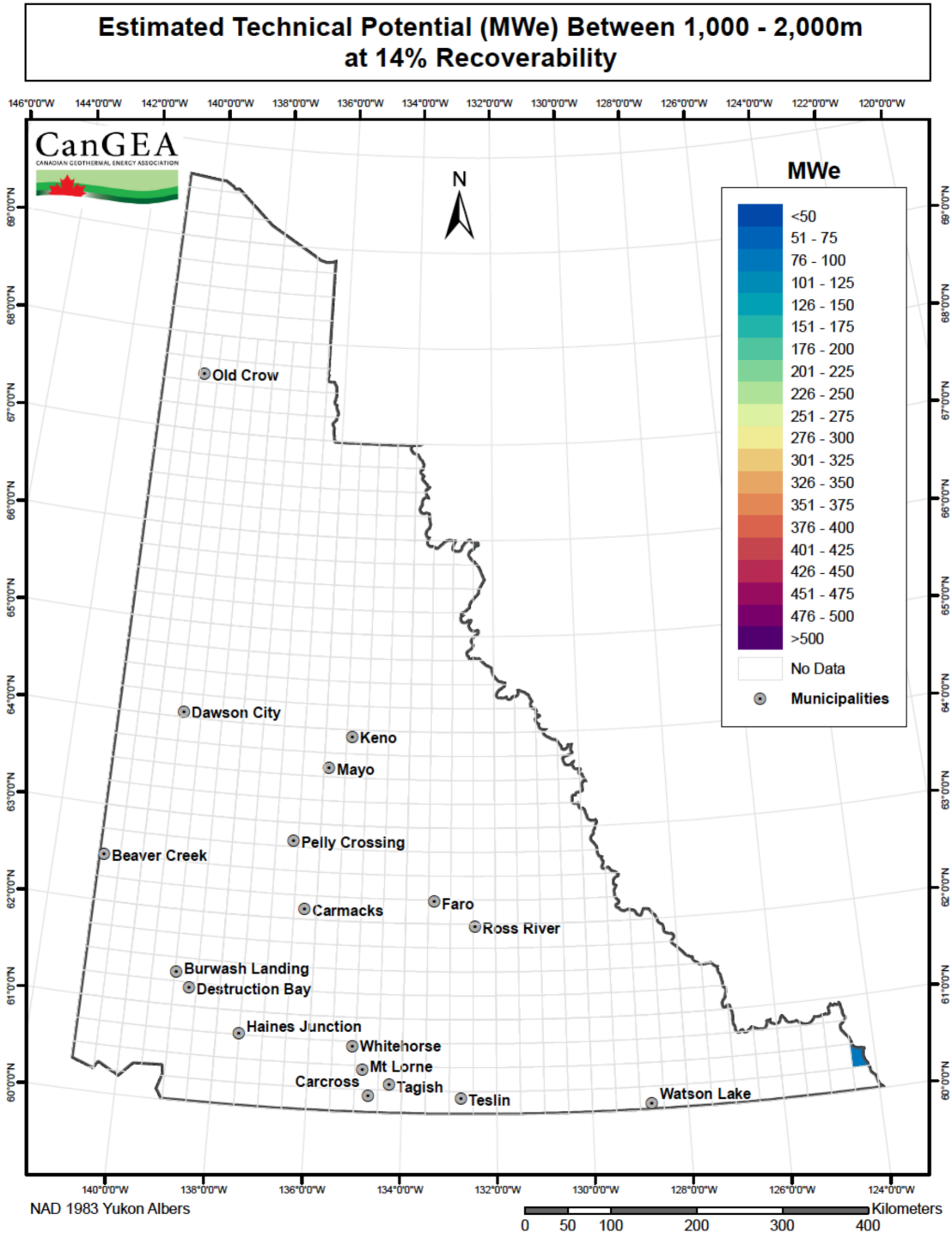

Figure 33: Technical potential between 1,000m and 2,000m at 14% recoverability

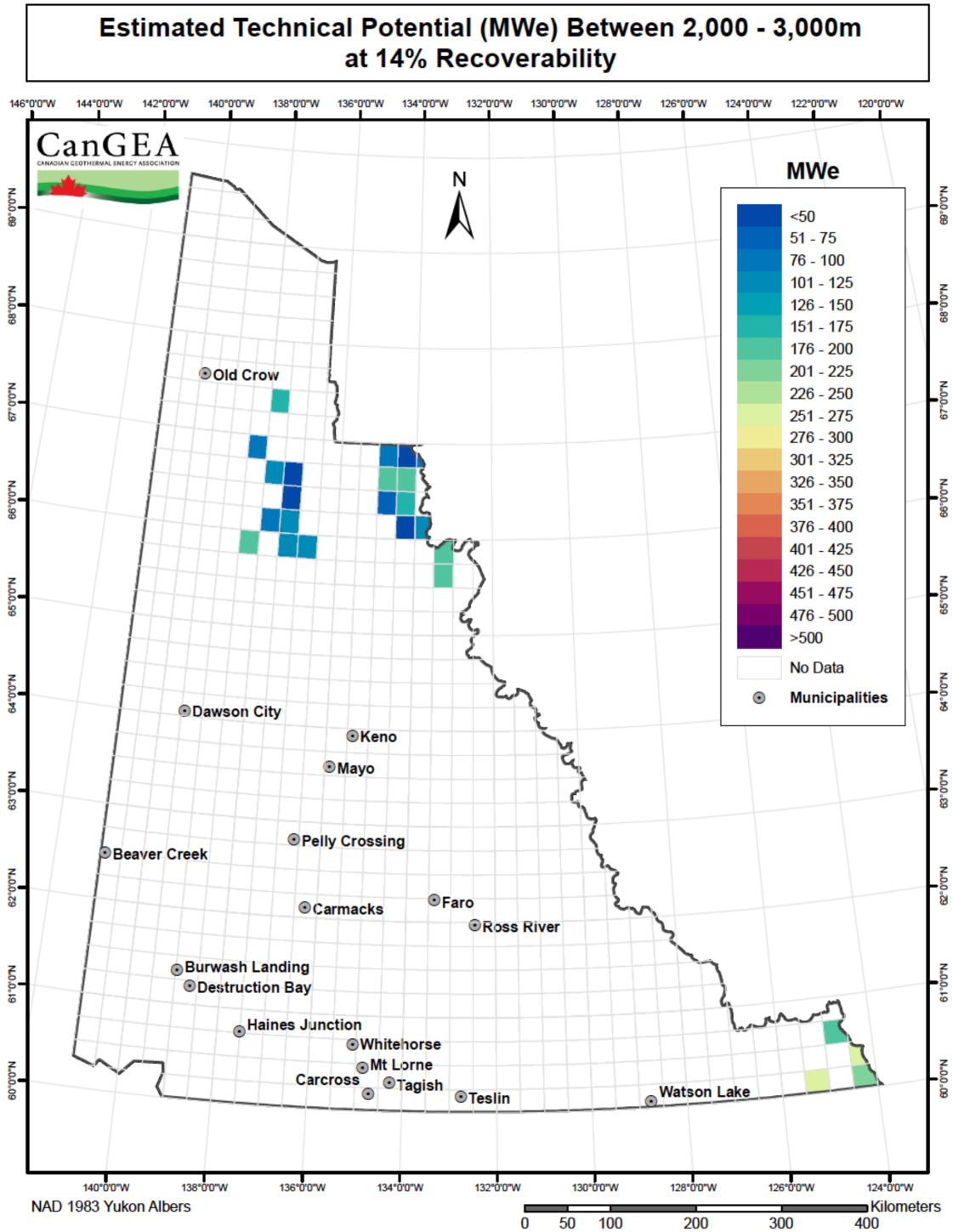

Figure 34: Technical potential between 2,000m and 3,000m at 14% recoverability

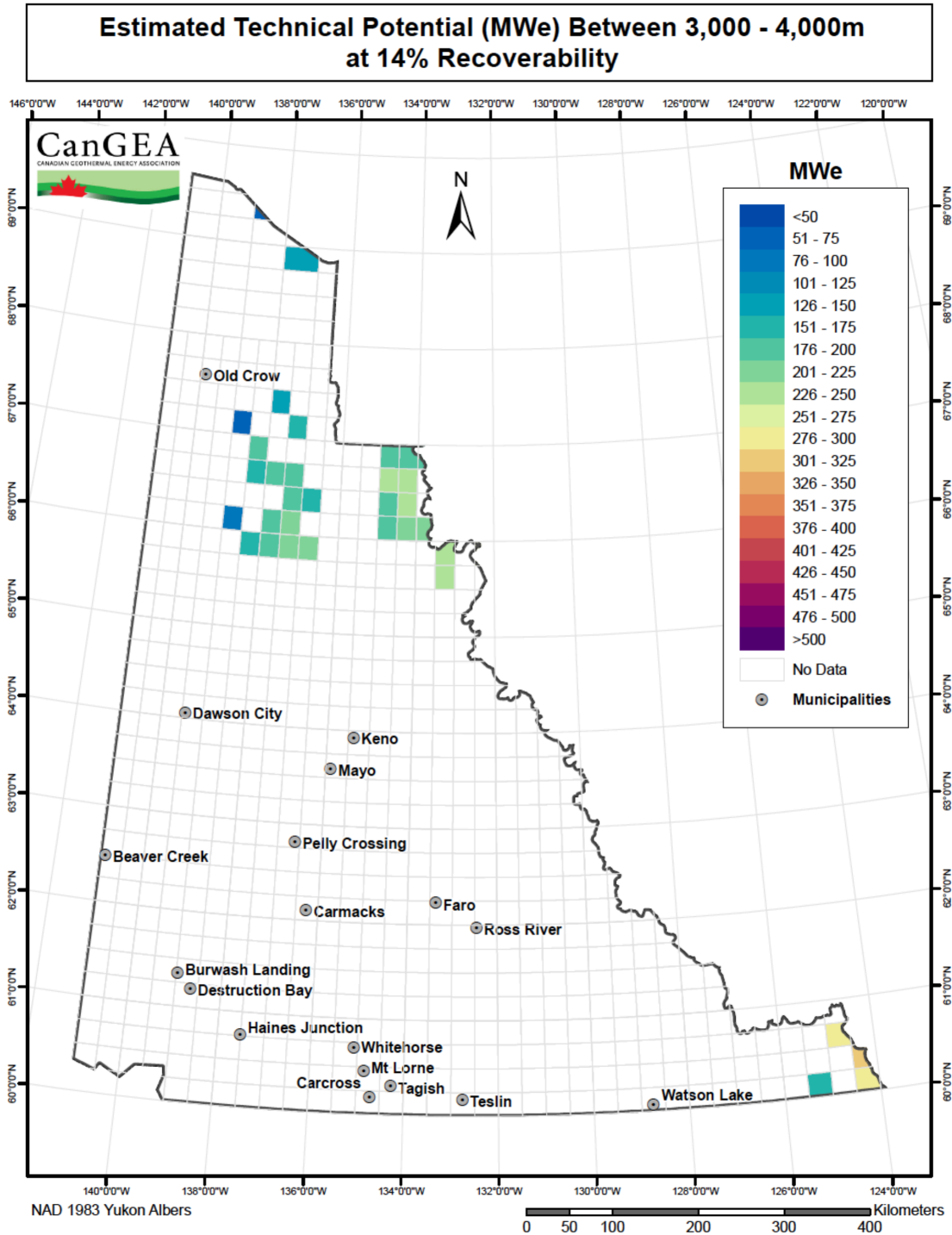

Figure 35: Technical potential between 3,000m and 4,000m at 14% recoverability

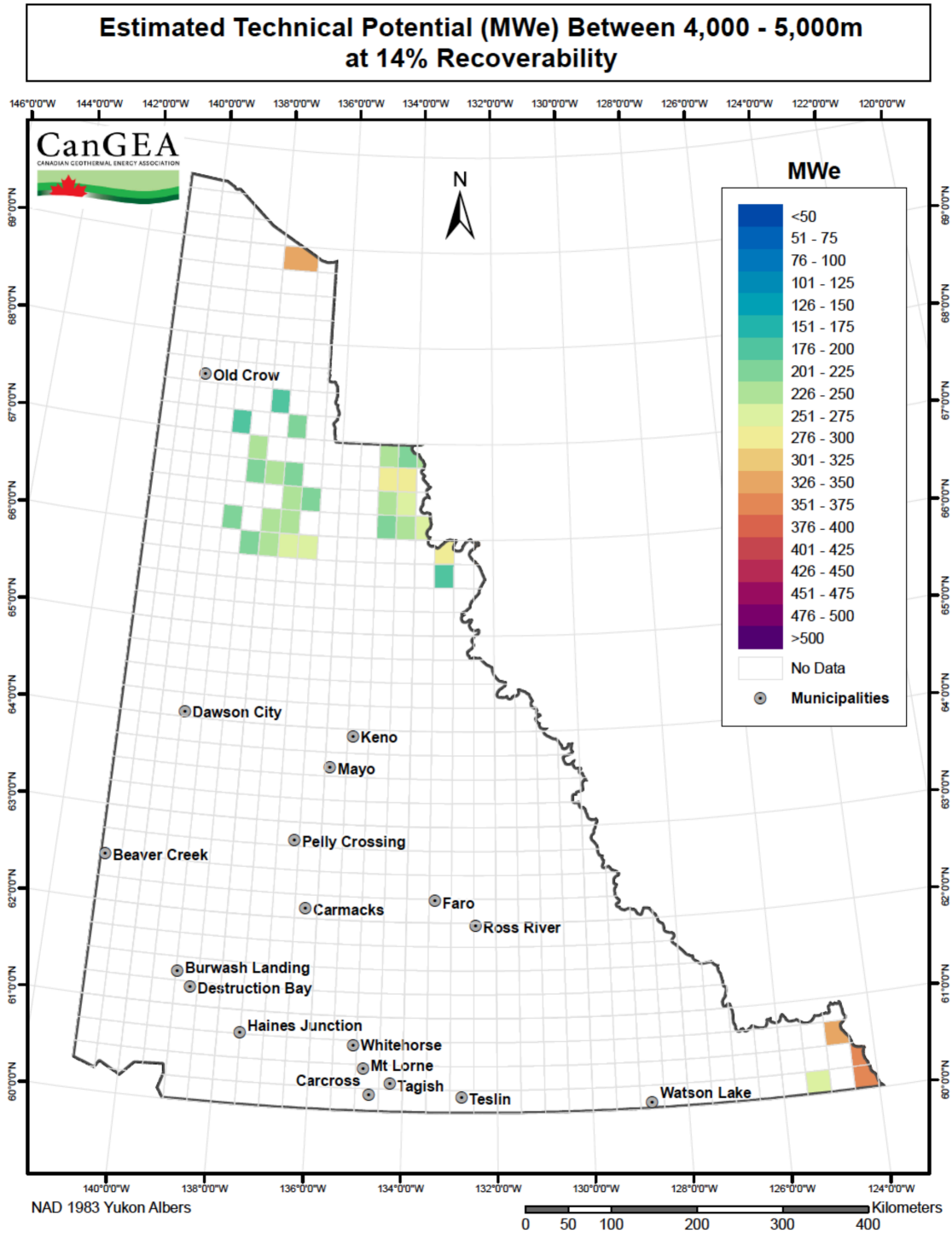

Figure 36: Technical potential between 4,000m and 5,000m at 14% recoverability

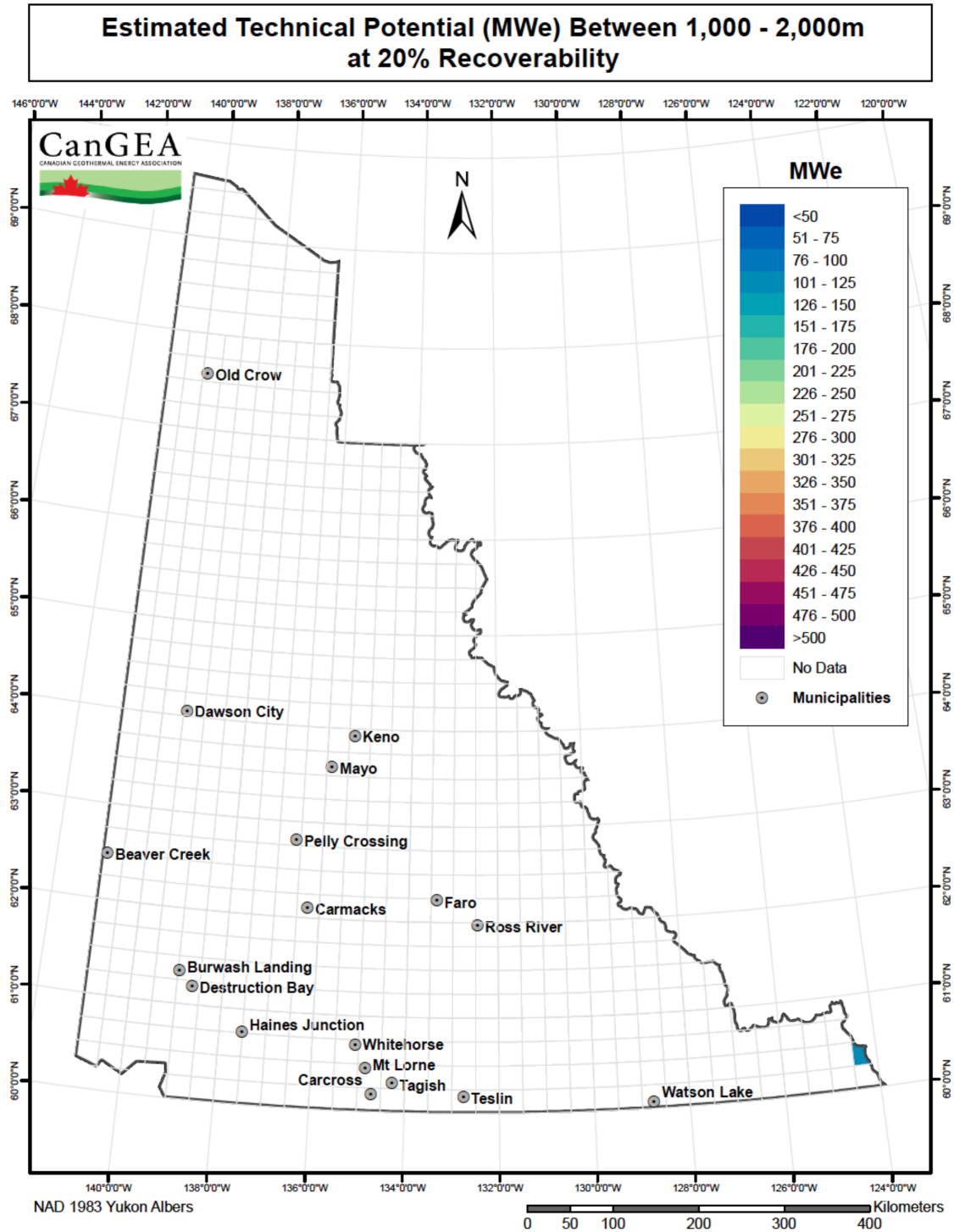

Figure 37: Technical potential between 1,000m and 2,000m at 20% recoverability

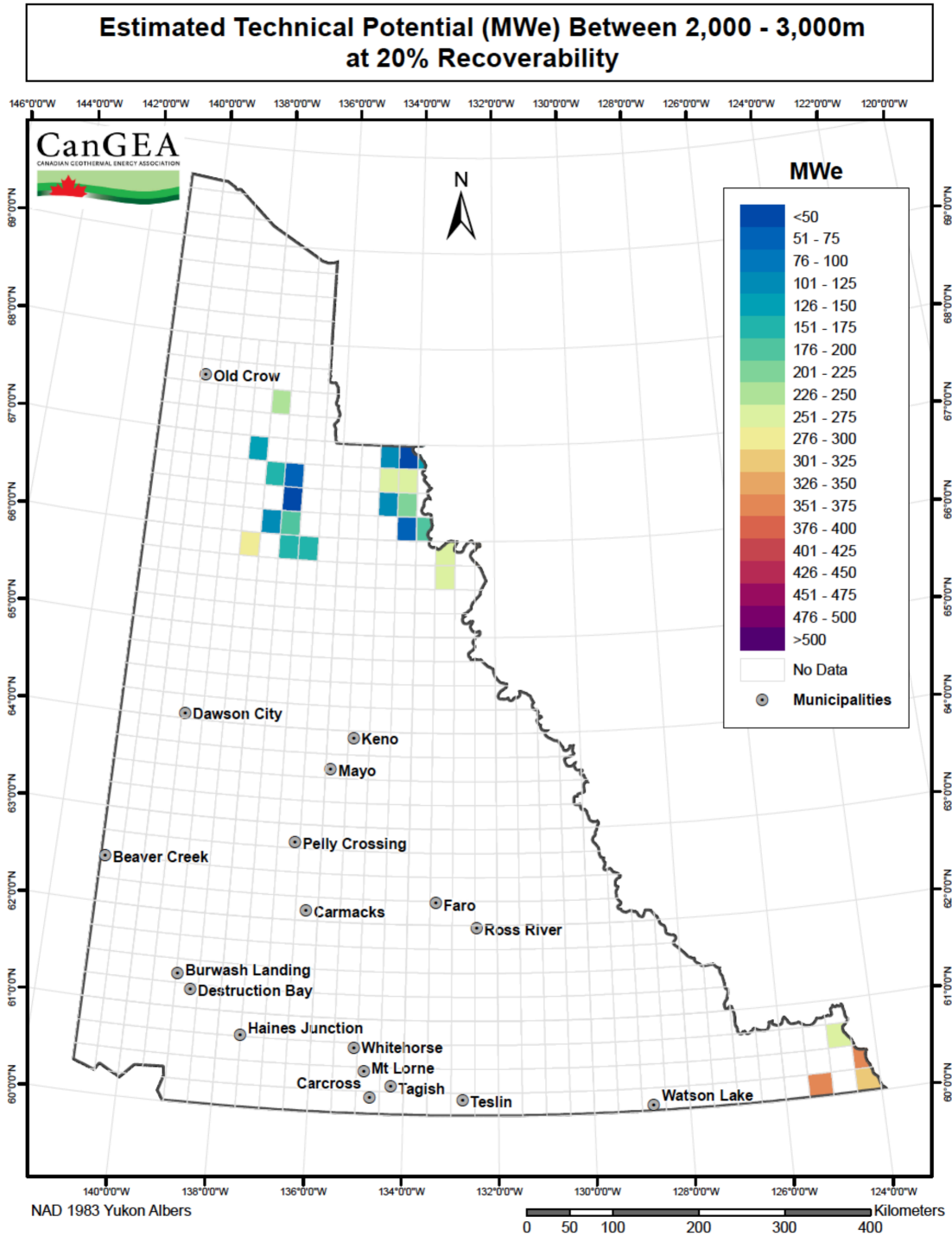

Figure 38: Technical potential between 2,000m and 3,000m at 20% recoverability

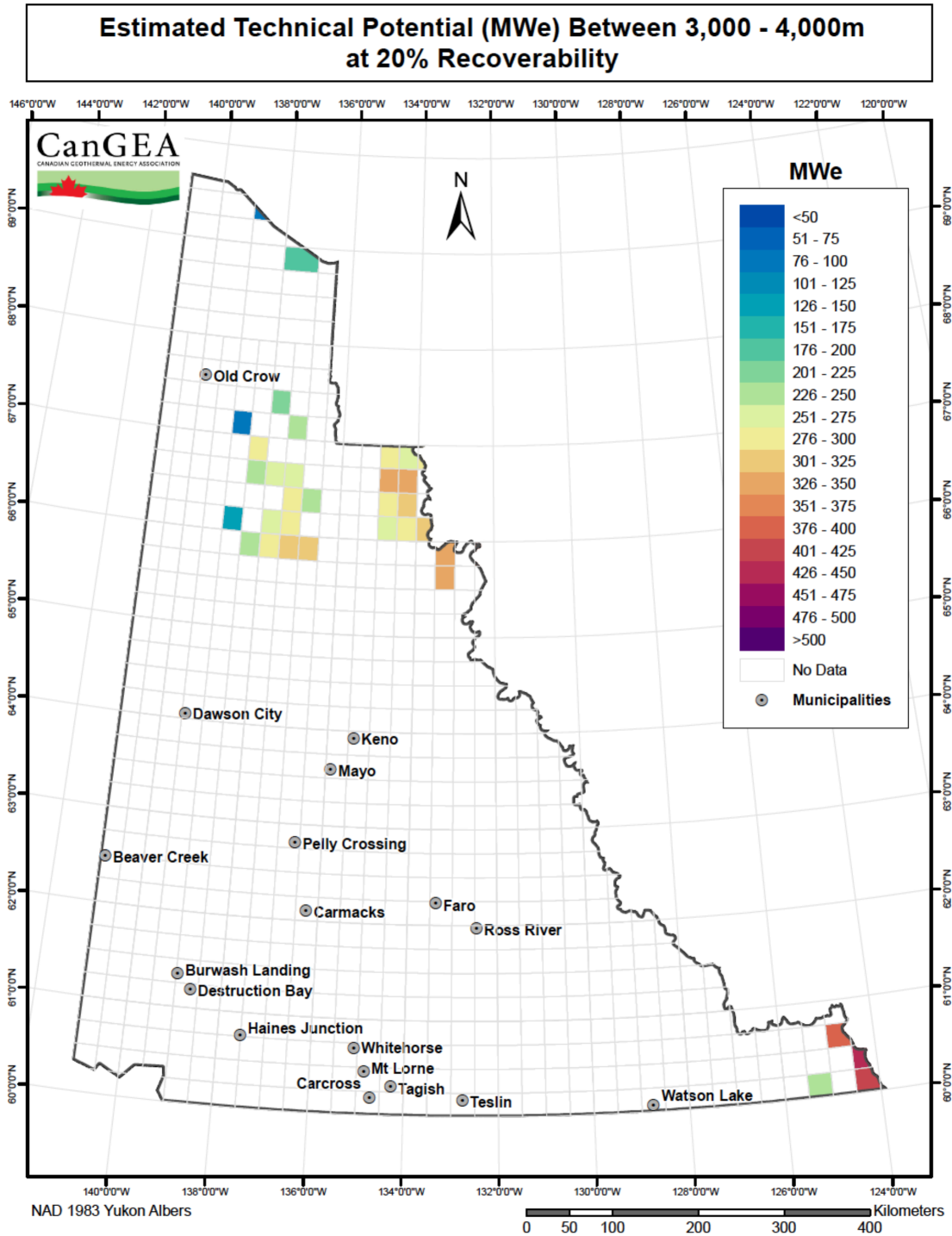

Figure 39: Technical potential between 3,000m and 4,000m at 20% recoverability

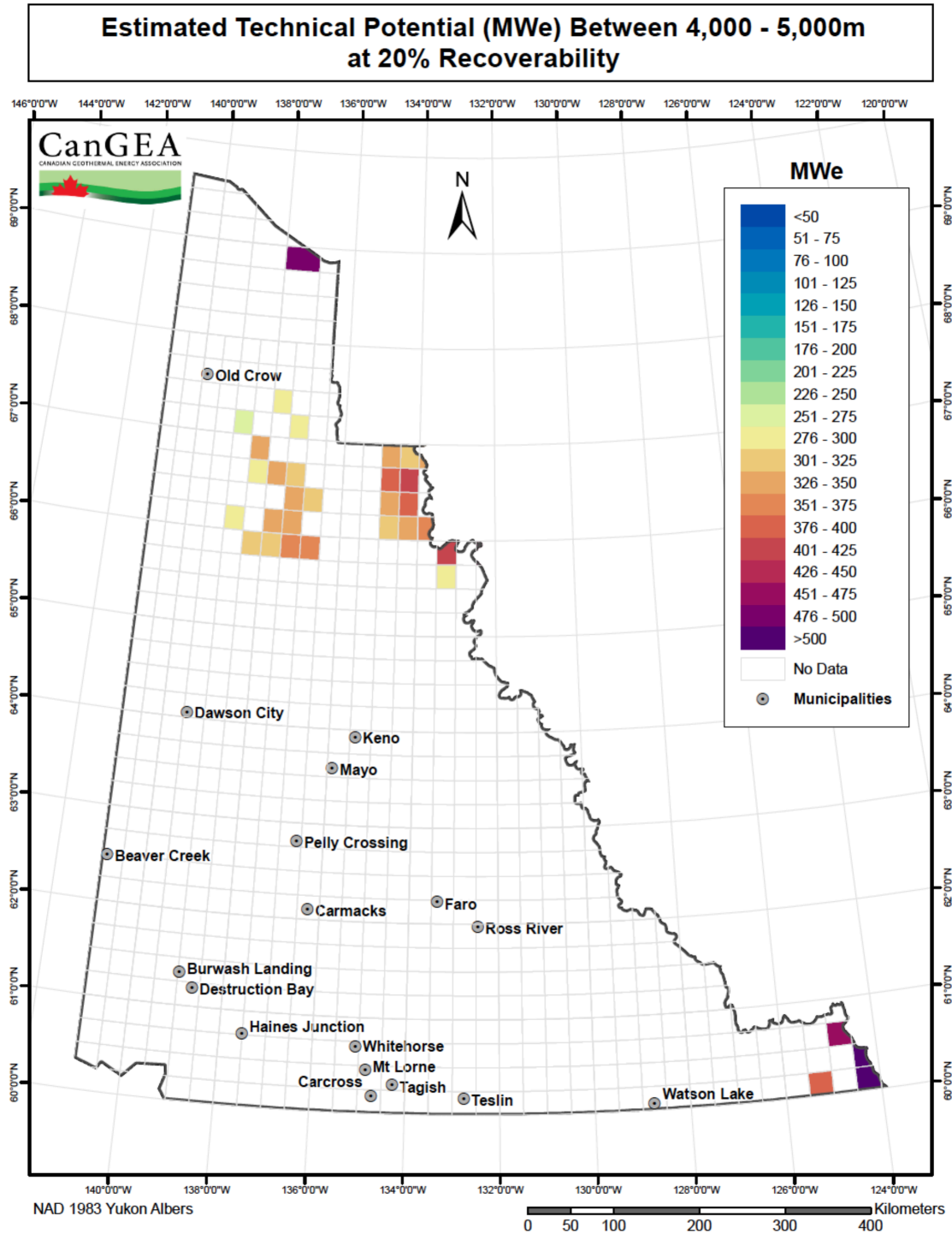

Figure 40: Technical potential between 4,000m and 5,000m at 20% recoverability

Theoretical Potential

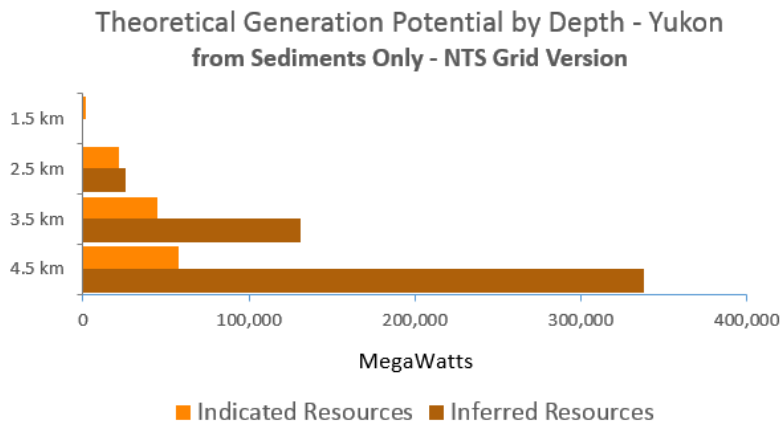

Figure 41: Theoretical generation potential by depth – Indicated vs. Inferred Resources

Theoretical Potential for Geothermal in Yukon NTS Grid Version		
Values Indicate Potential Power (Indicated and Inferred Resources)		
Depth	Generation Potential	
	Indicated Resources	Inferred Resources
1,500m:	1,894 MW	0 MW
2,500m:	21,403 MW	25,693 MW
3,500m:	45,191 MW	131,297 MW
4,500m:	57,466 MW	337,696 MW
Total:	125,954 MW	494,686 MW
Installed Generation Capacity (All Sources):		0 MW

Figure 42: Theoretical generation potential by depth – Indicated vs. Inferred Resources - detailed

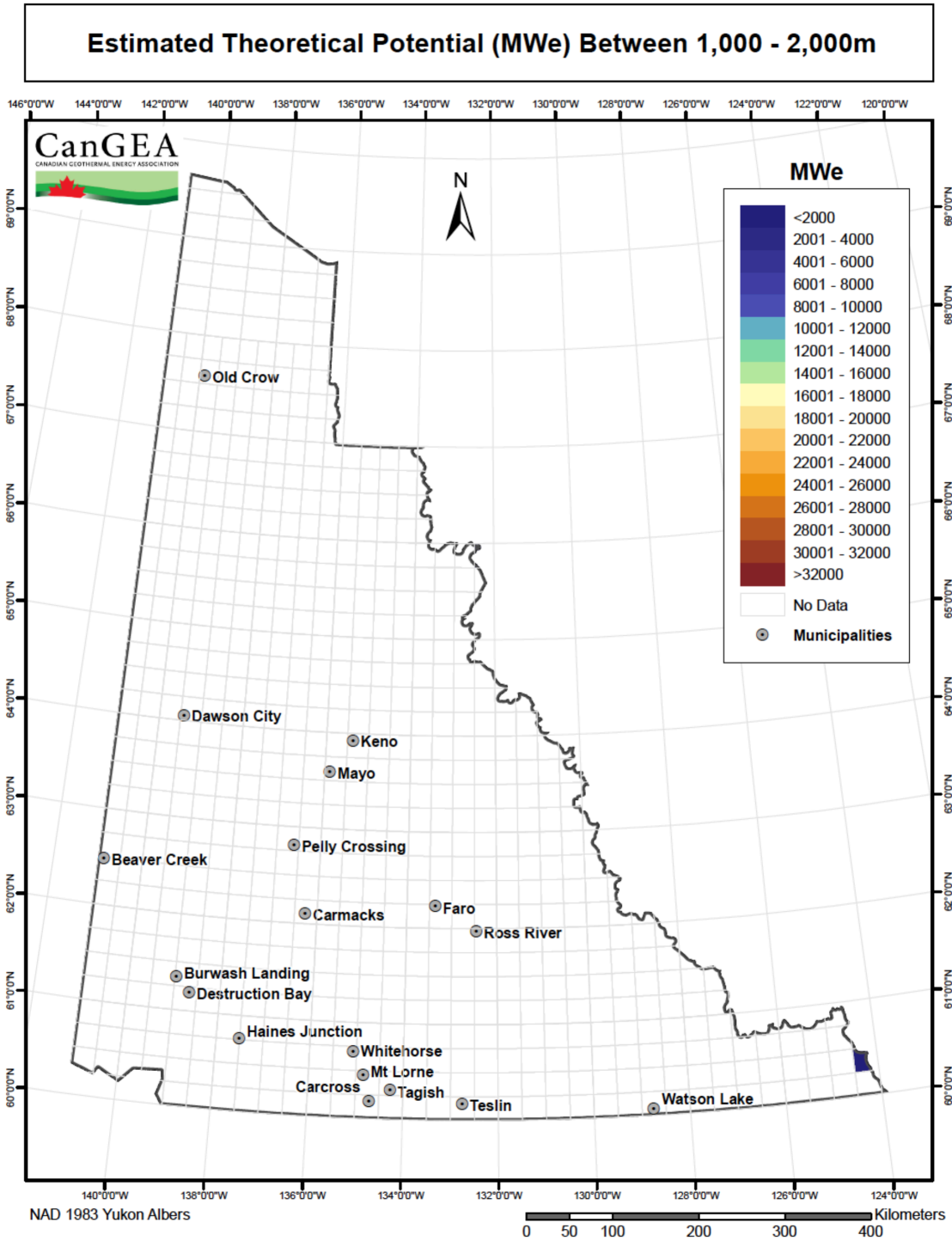

Figure 43: Theoretical potential between 1,000m and 2,000m

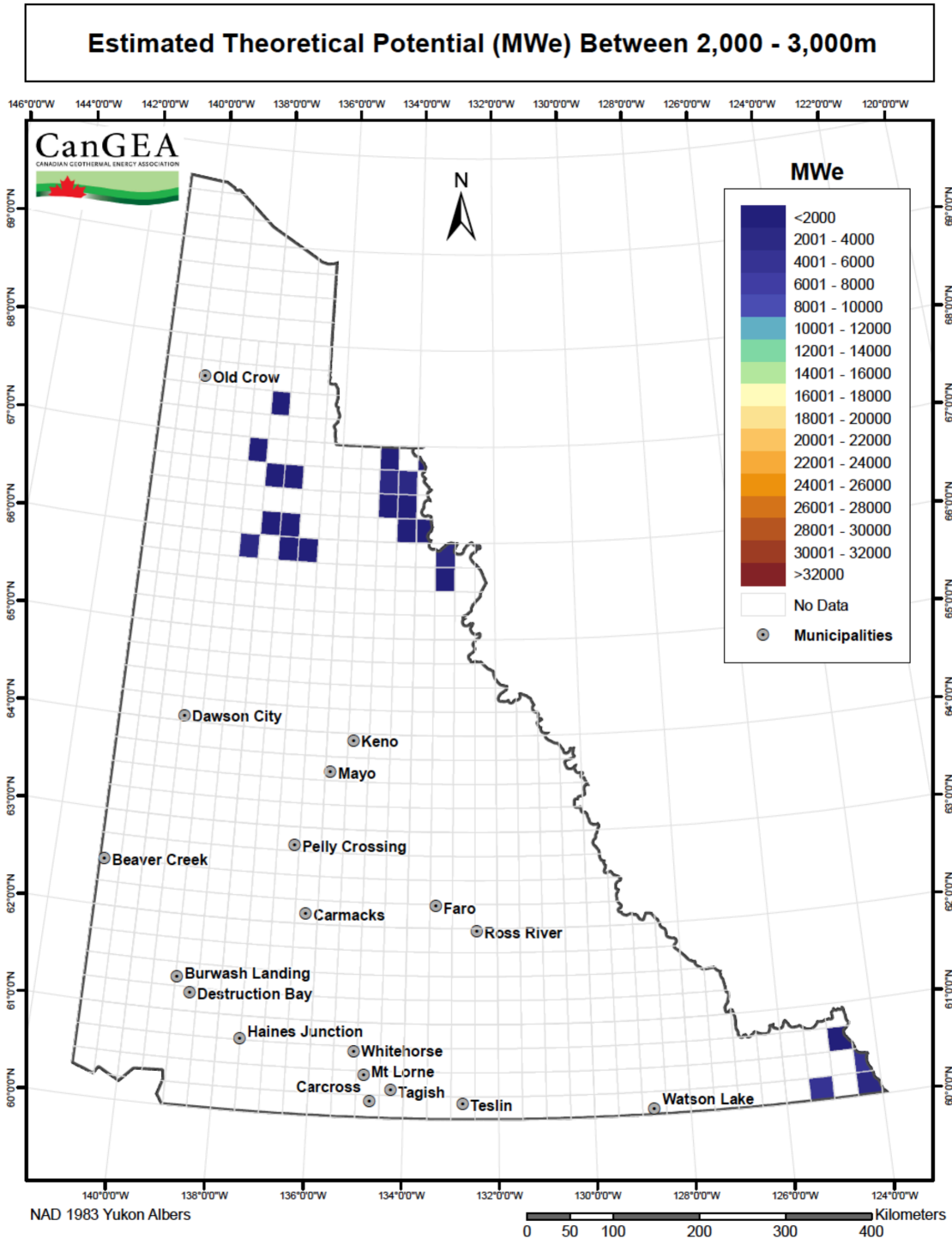

Figure 44: Theoretical potential between 2,000m and 3,000m

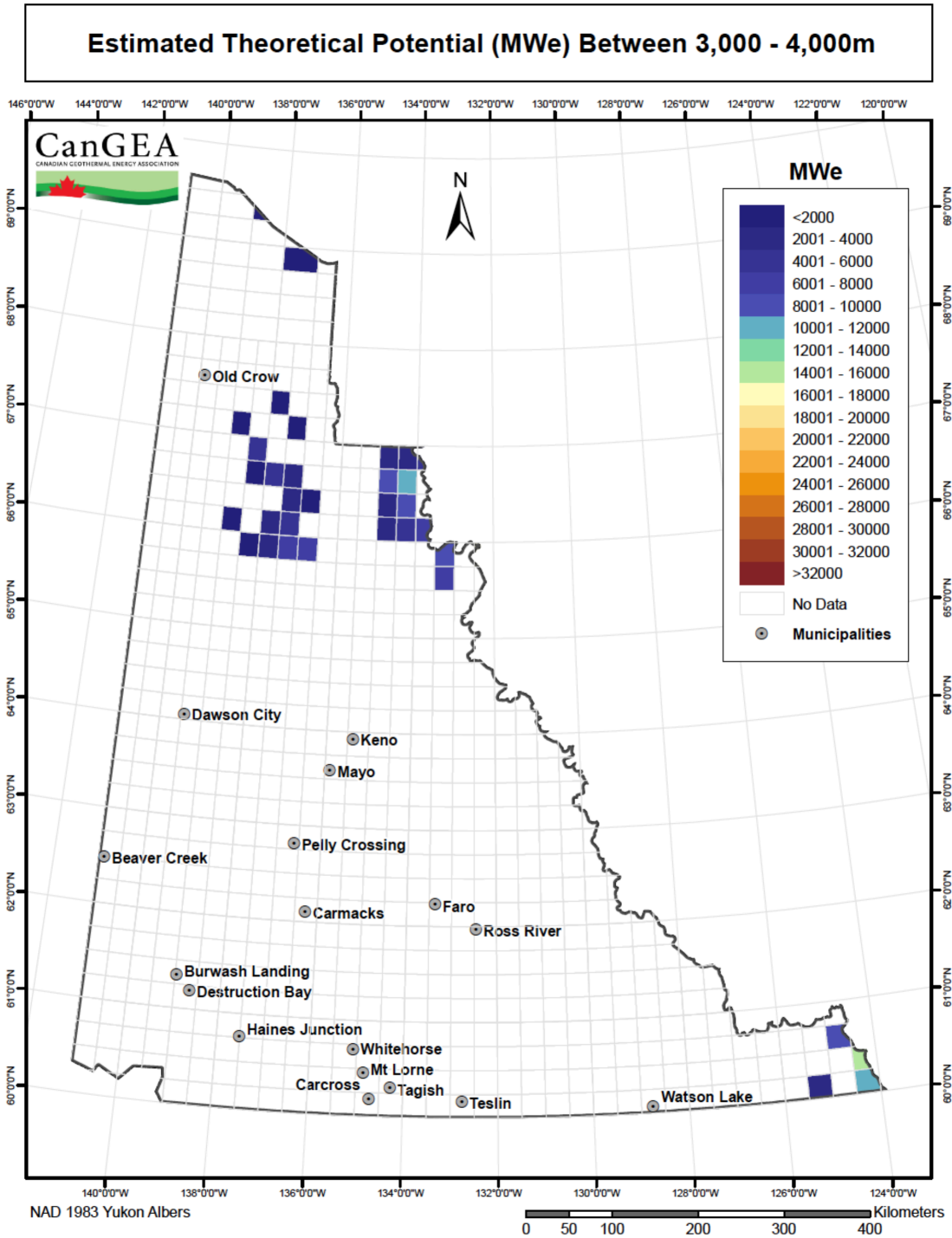

Figure 45: Theoretical potential between 3,000m and 4,000m

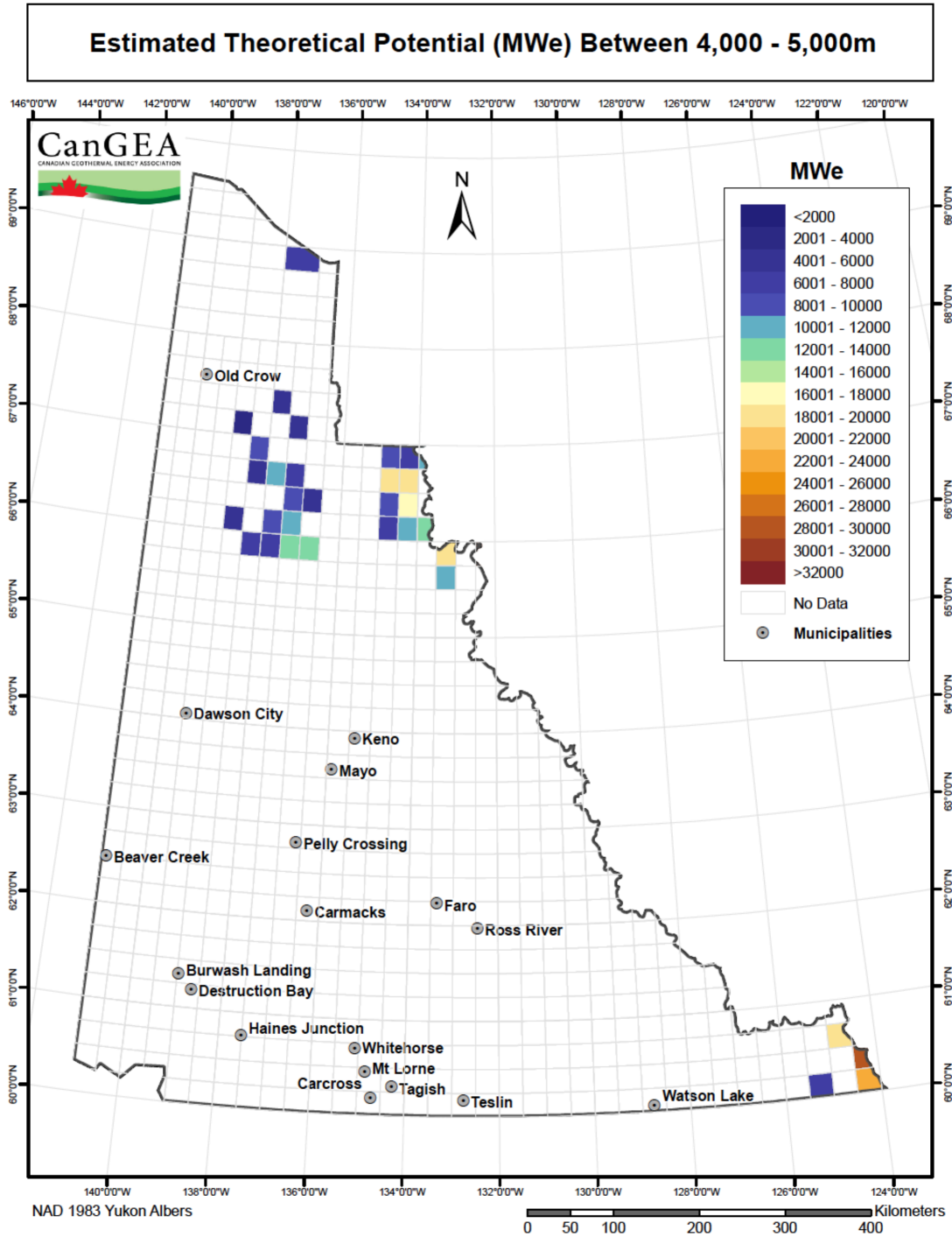

Figure 46: Theoretical potential between 4,000m and 5,000m

Inferred vs. Indicated Resources Maps

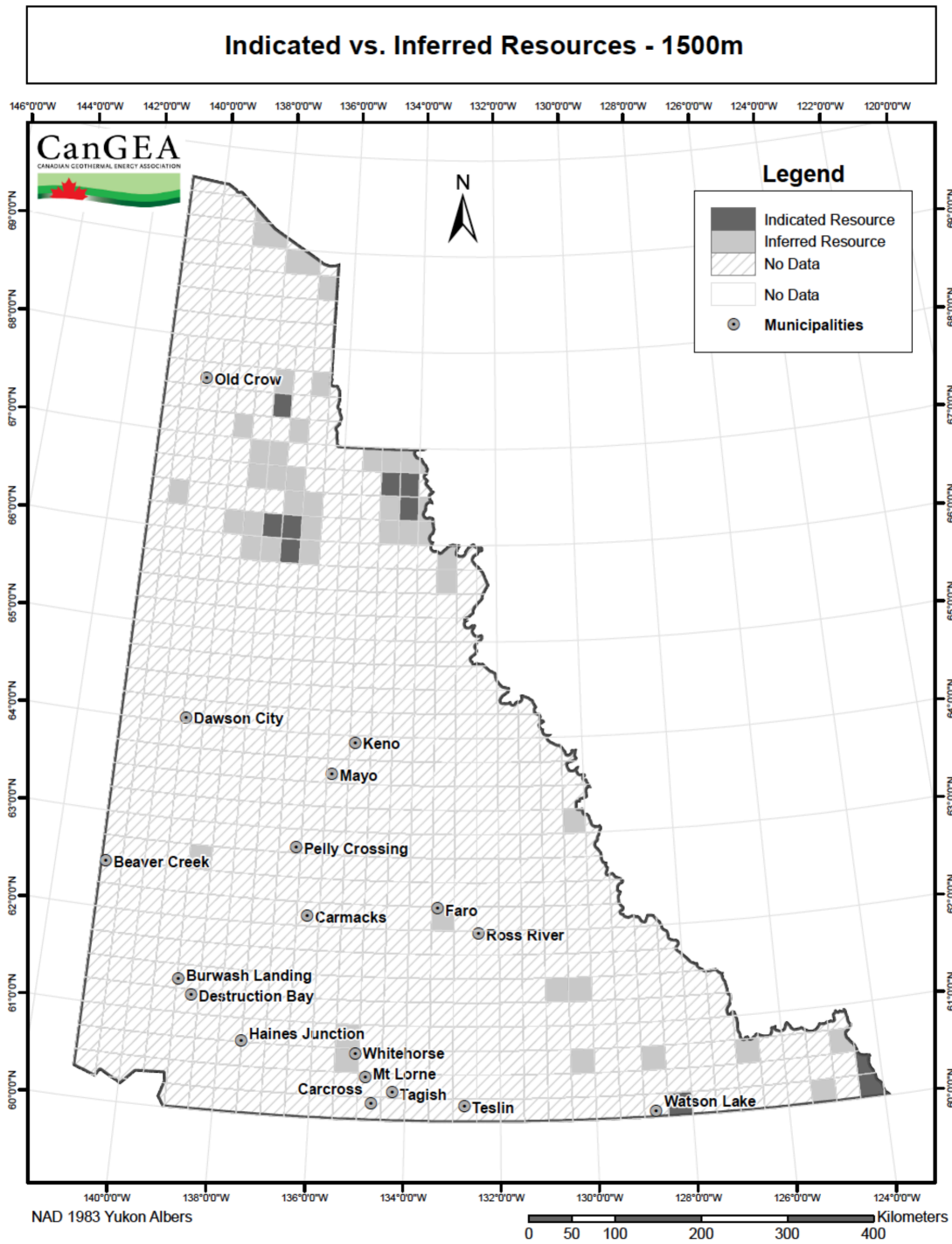

Figure 47: Map of indicated vs. inferred resources – 1,500m

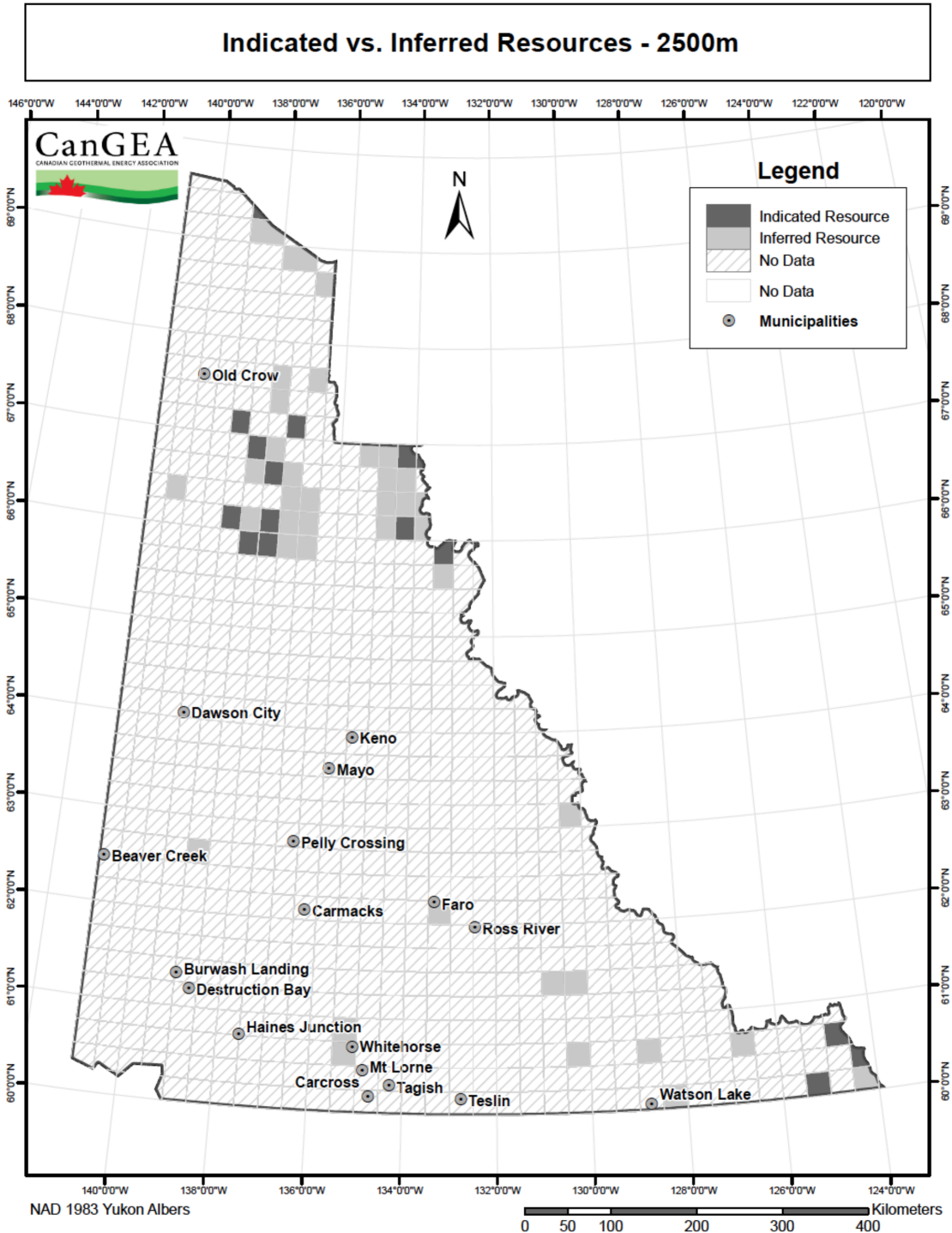

Figure 48: Map of indicated vs. inferred resources – 2,500m

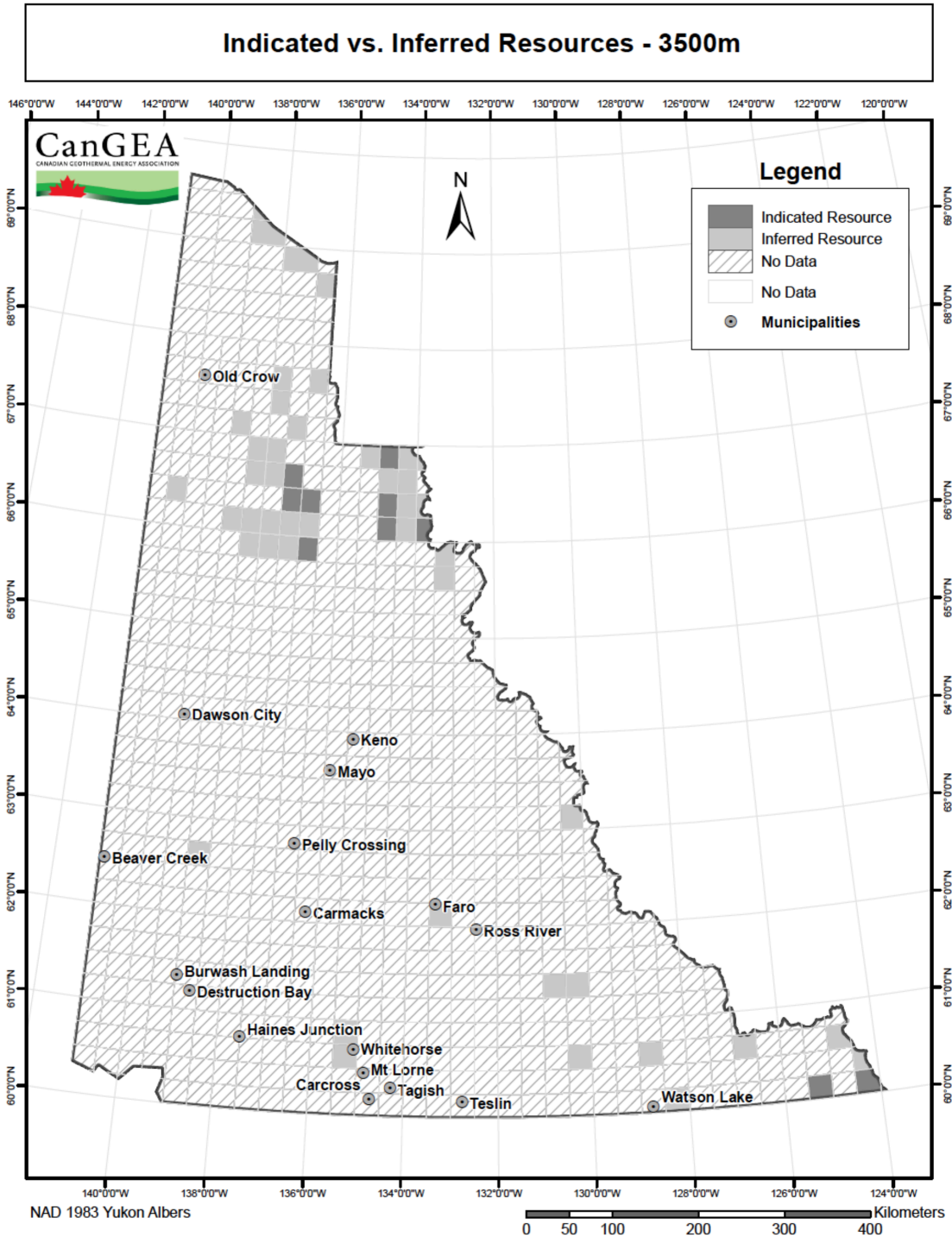

Figure 49: Map of indicated vs. inferred resources – 3,500m

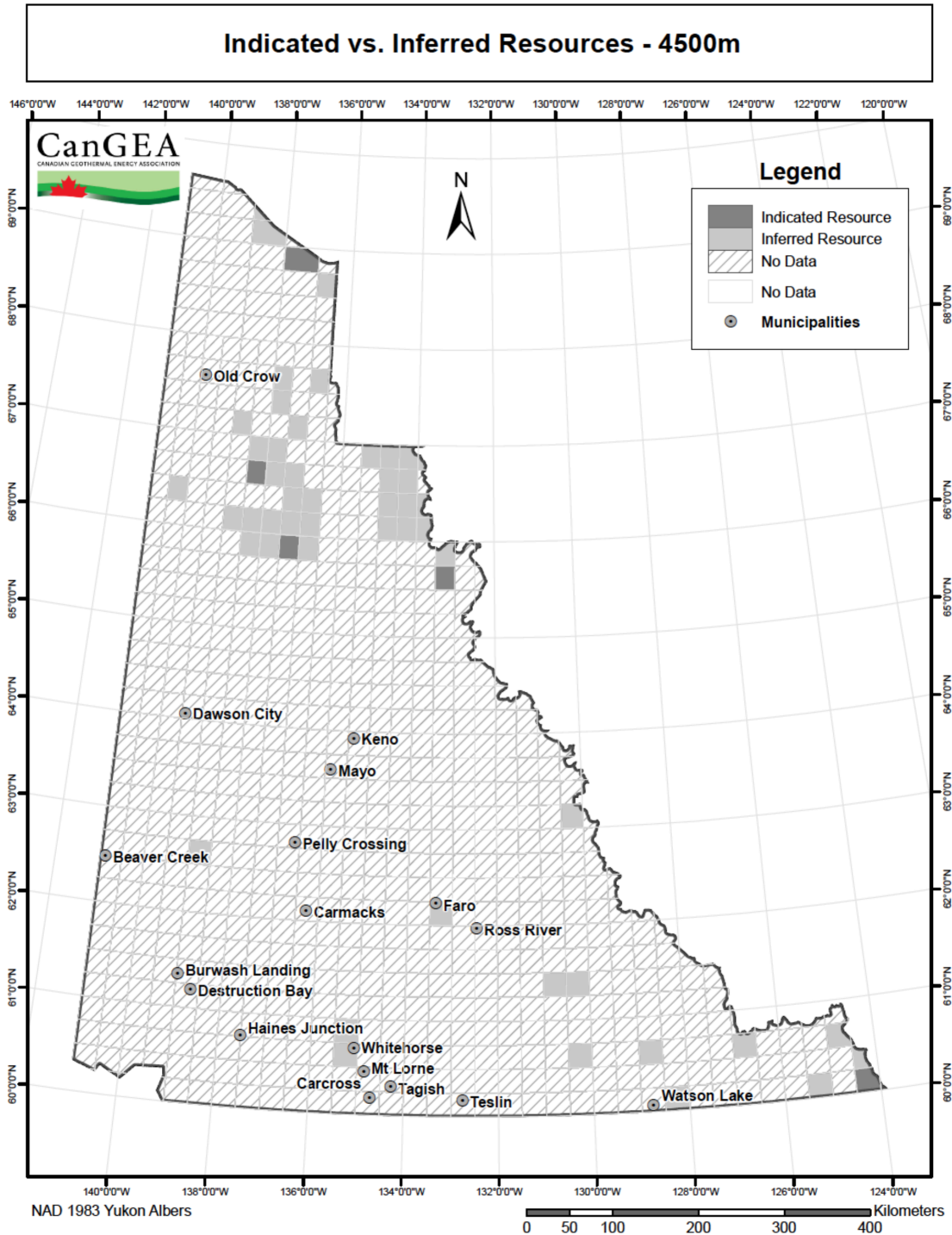

Figure 50: Map of indicated vs. inferred resources – 4,500m

Supplemental Maps

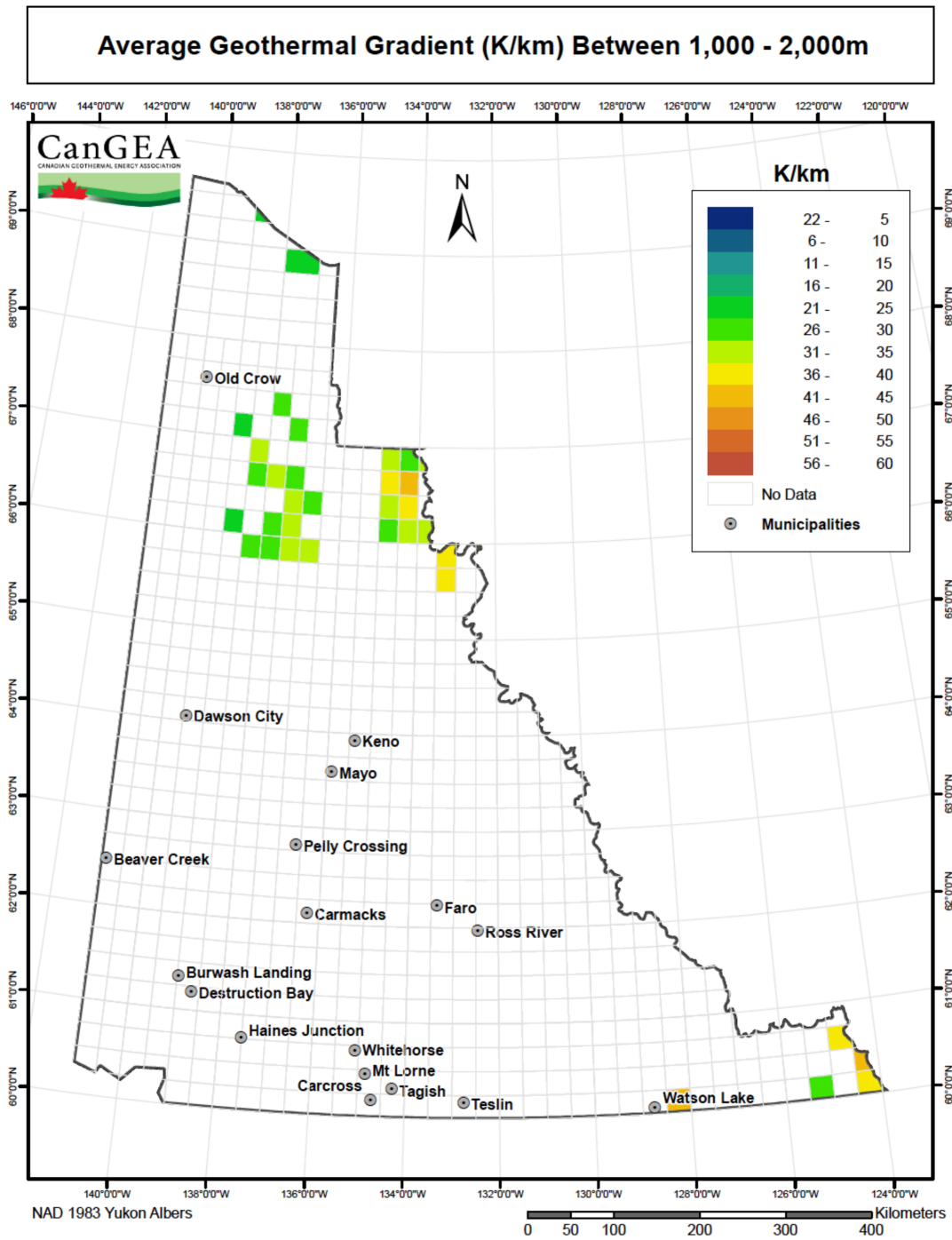

Figure 51: Average geothermal gradient – 1,000m – 2,000m

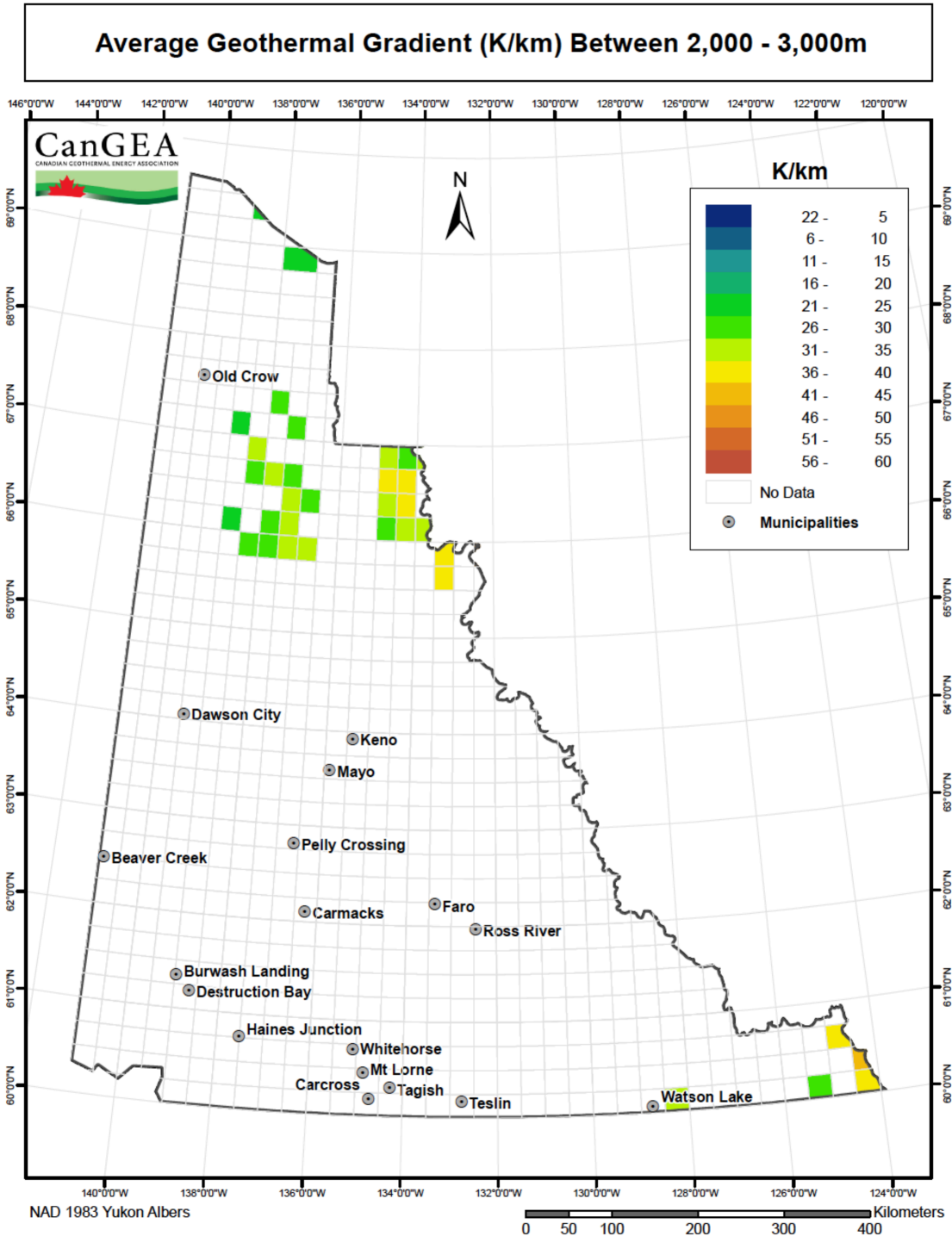

Figure 52: Average geothermal gradient – 2,000m – 3,000m

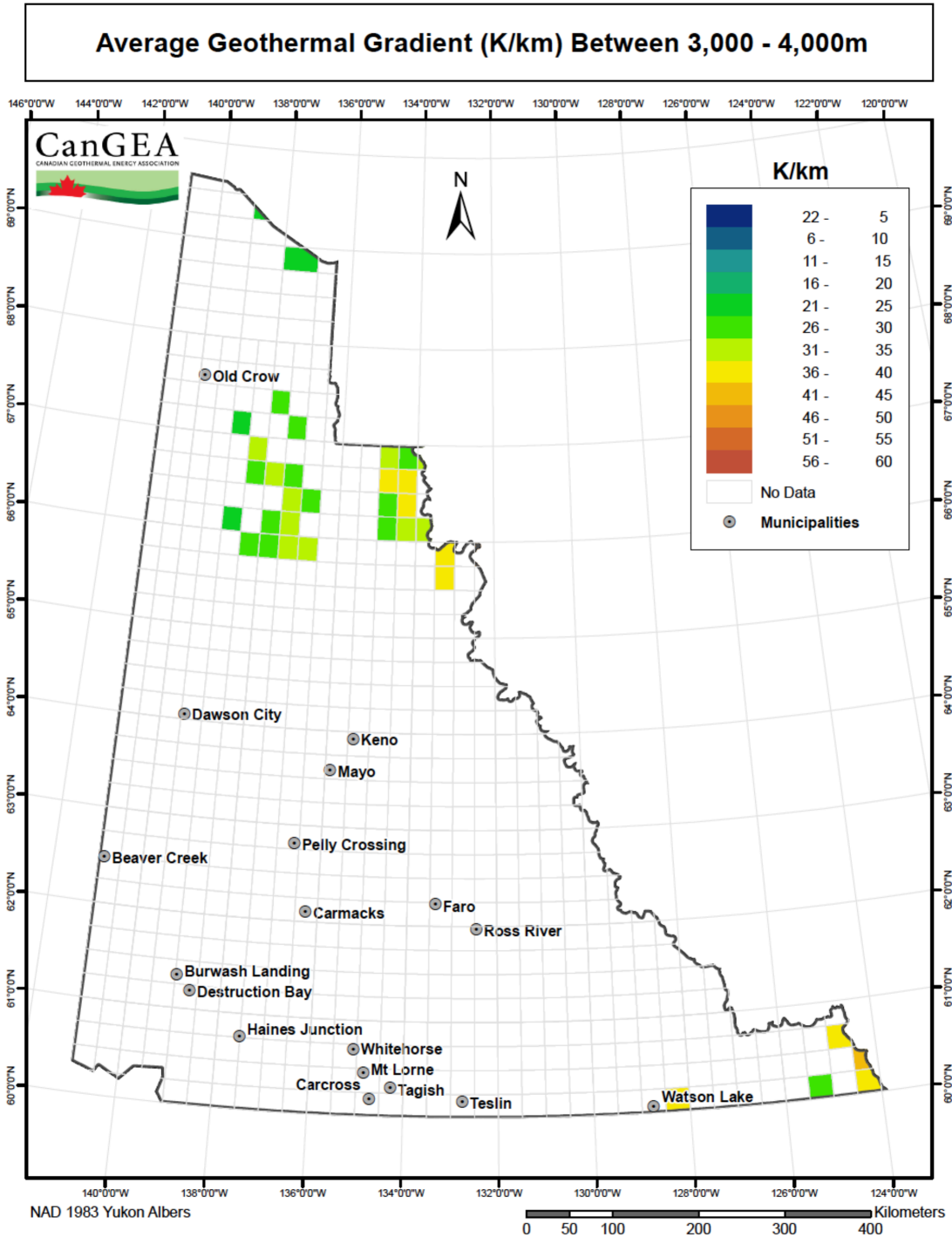

Figure 53: Average geothermal gradient – 3,000m – 4,000m

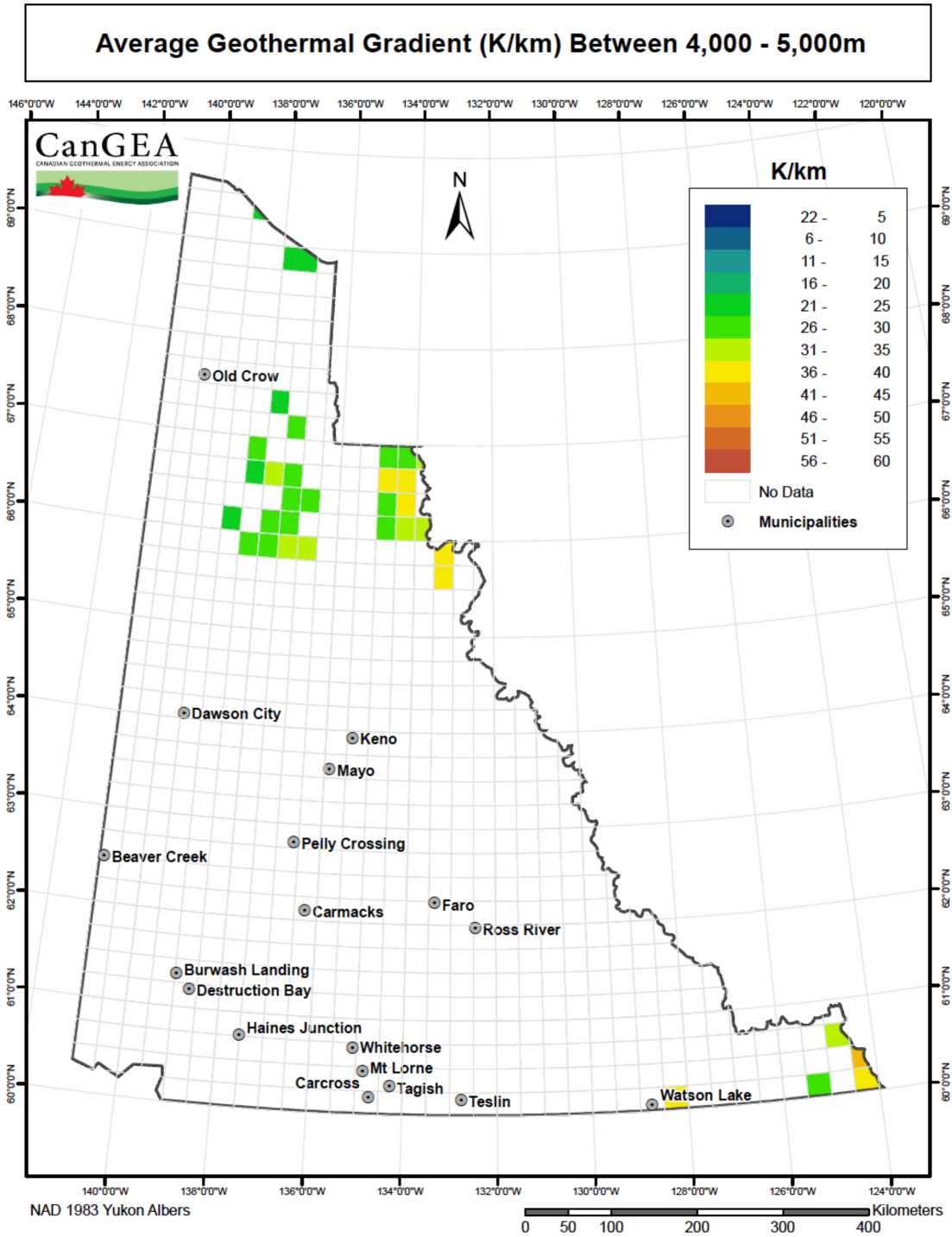

Figure 54: Average geothermal gradient – 4,000m – 5,000m

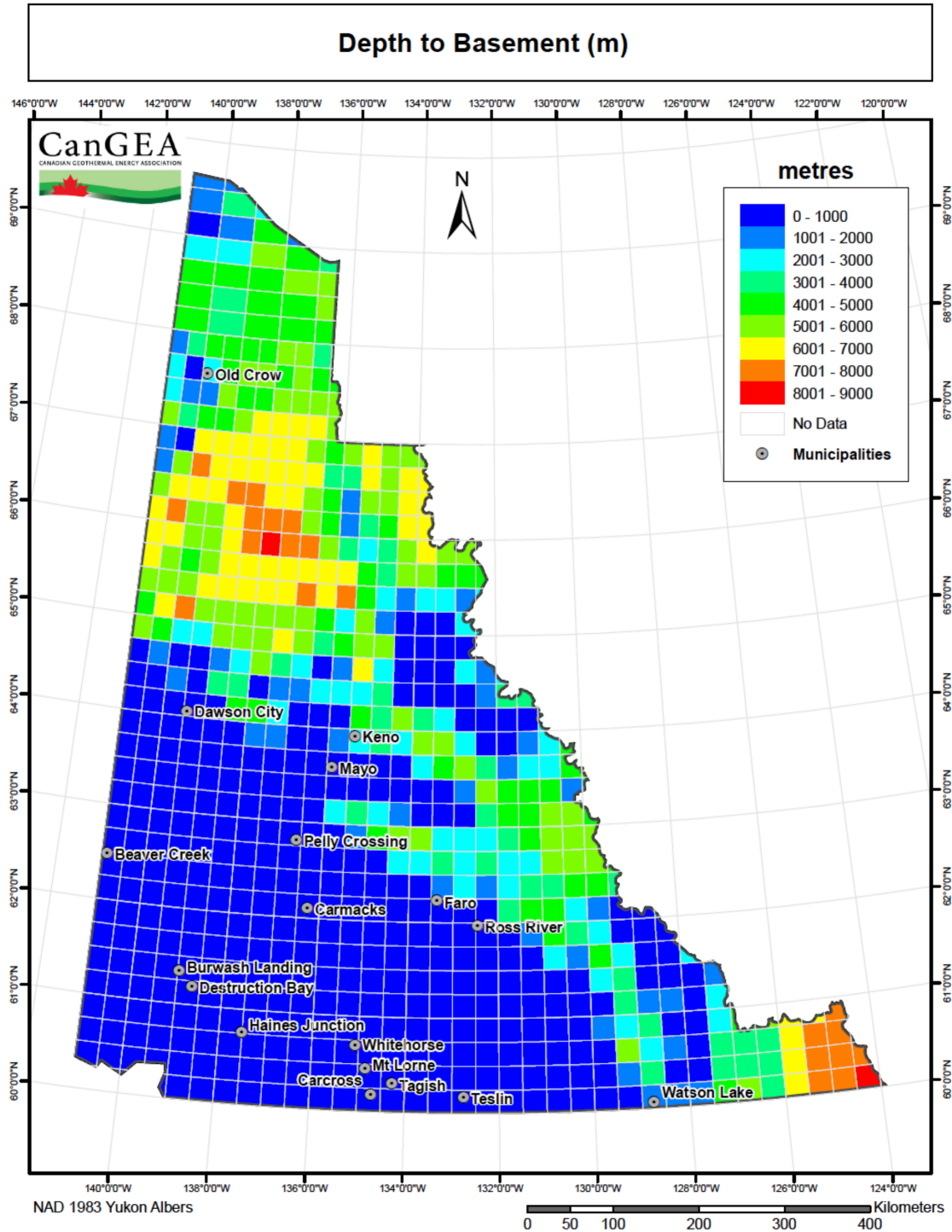

Figure 55: Depth to basement

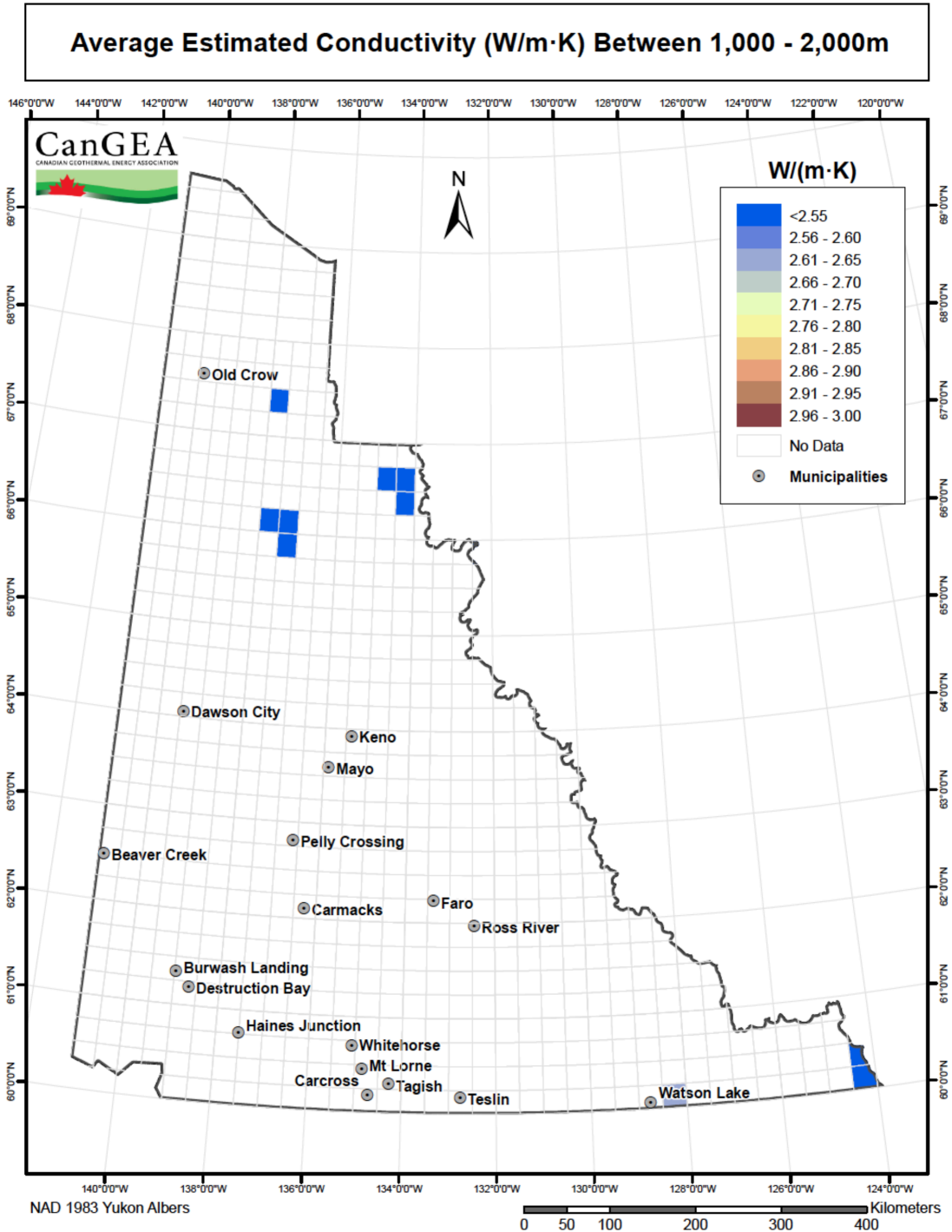

Figure 56: Average estimated conductivity – 1,000m – 2,000m

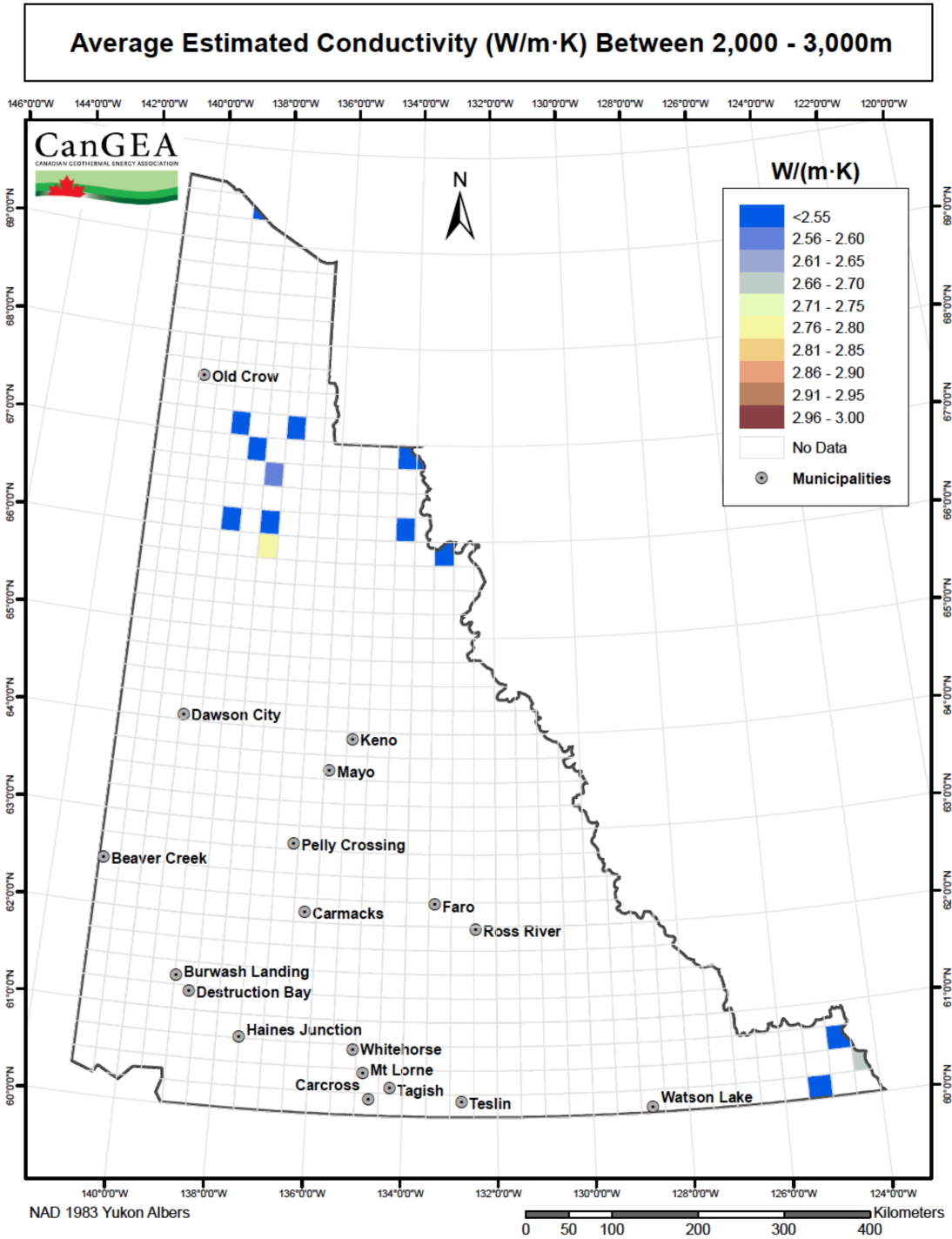

Figure 57: Average estimated conductivity – 2,000m – 3,000m

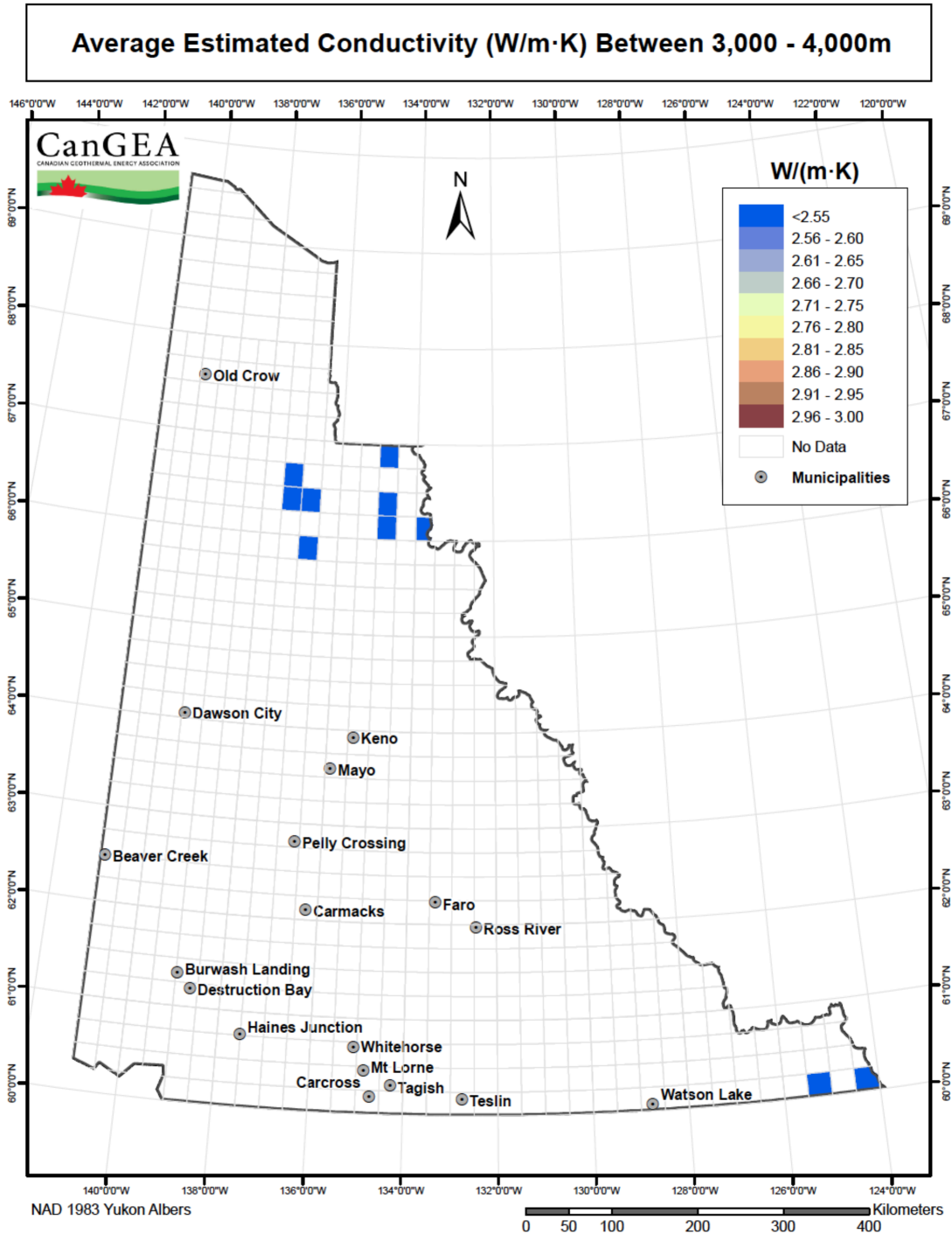

Figure 58: Average estimated conductivity – 3,000m – 4,000m

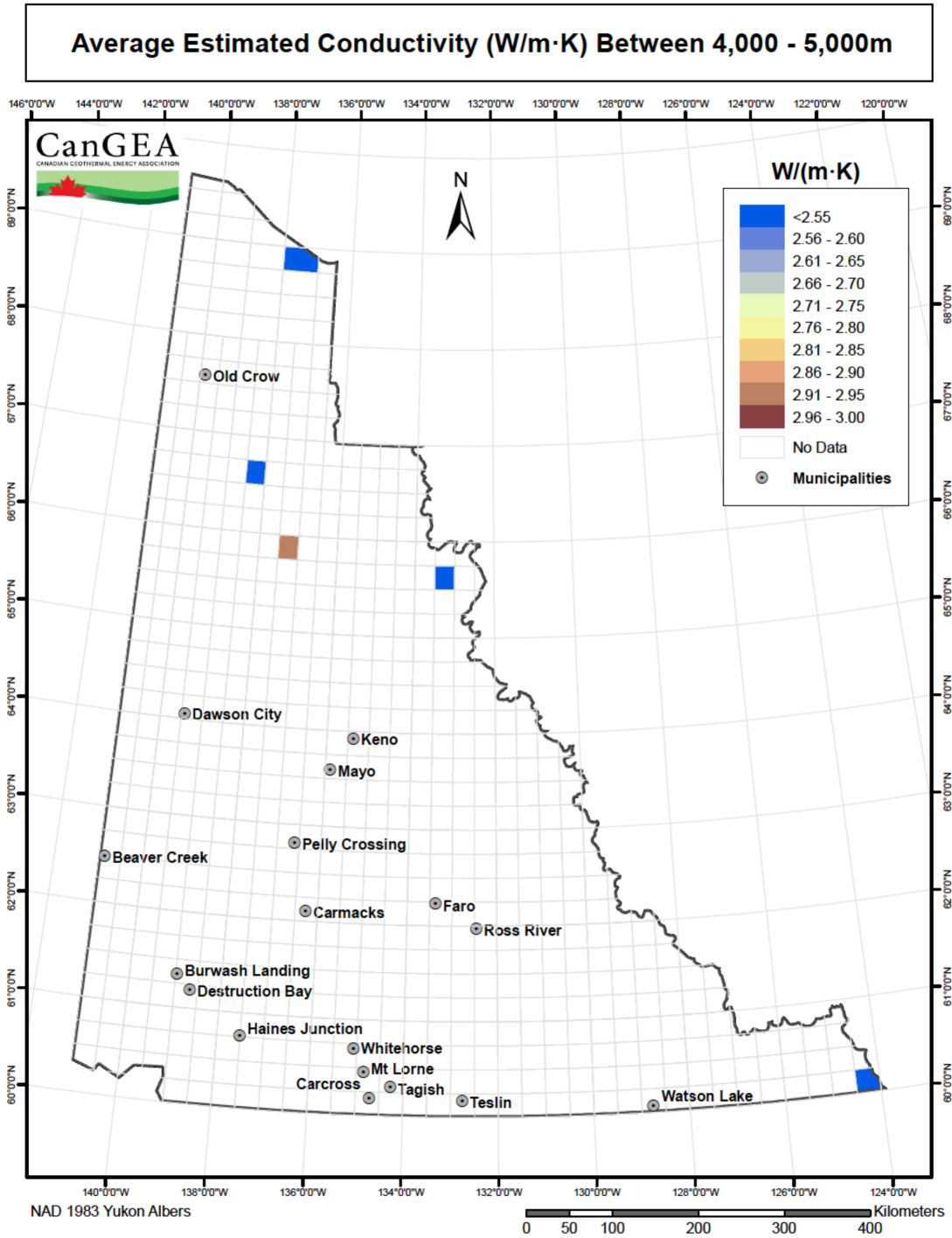

Figure 59: Average estimated conductivity – 4,000m – 5,000m

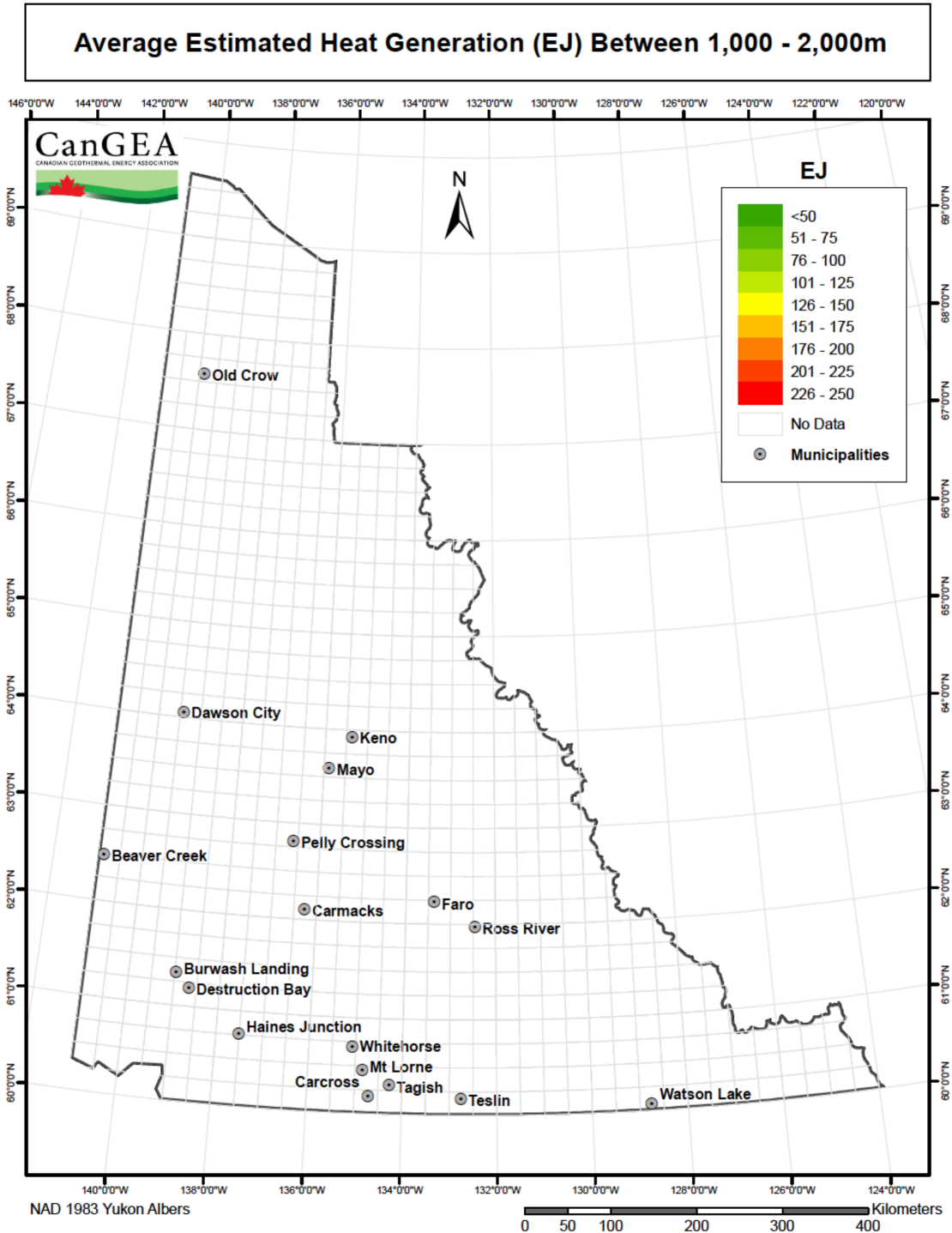

Figure 60: Average estimated heat generation – 1,000m – 2,000m

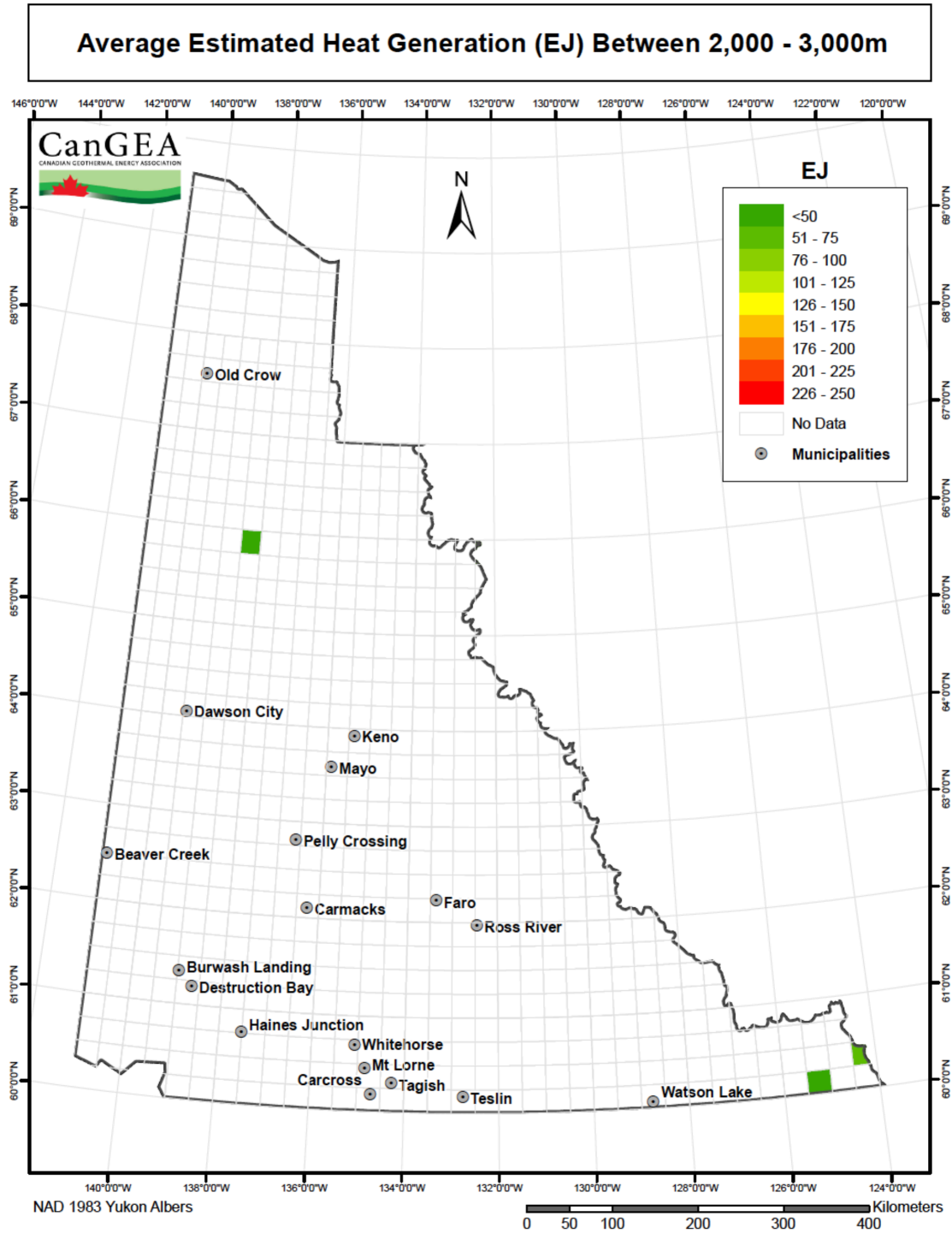

Figure 61: Average estimated heat generation – 2,000m – 3,000m

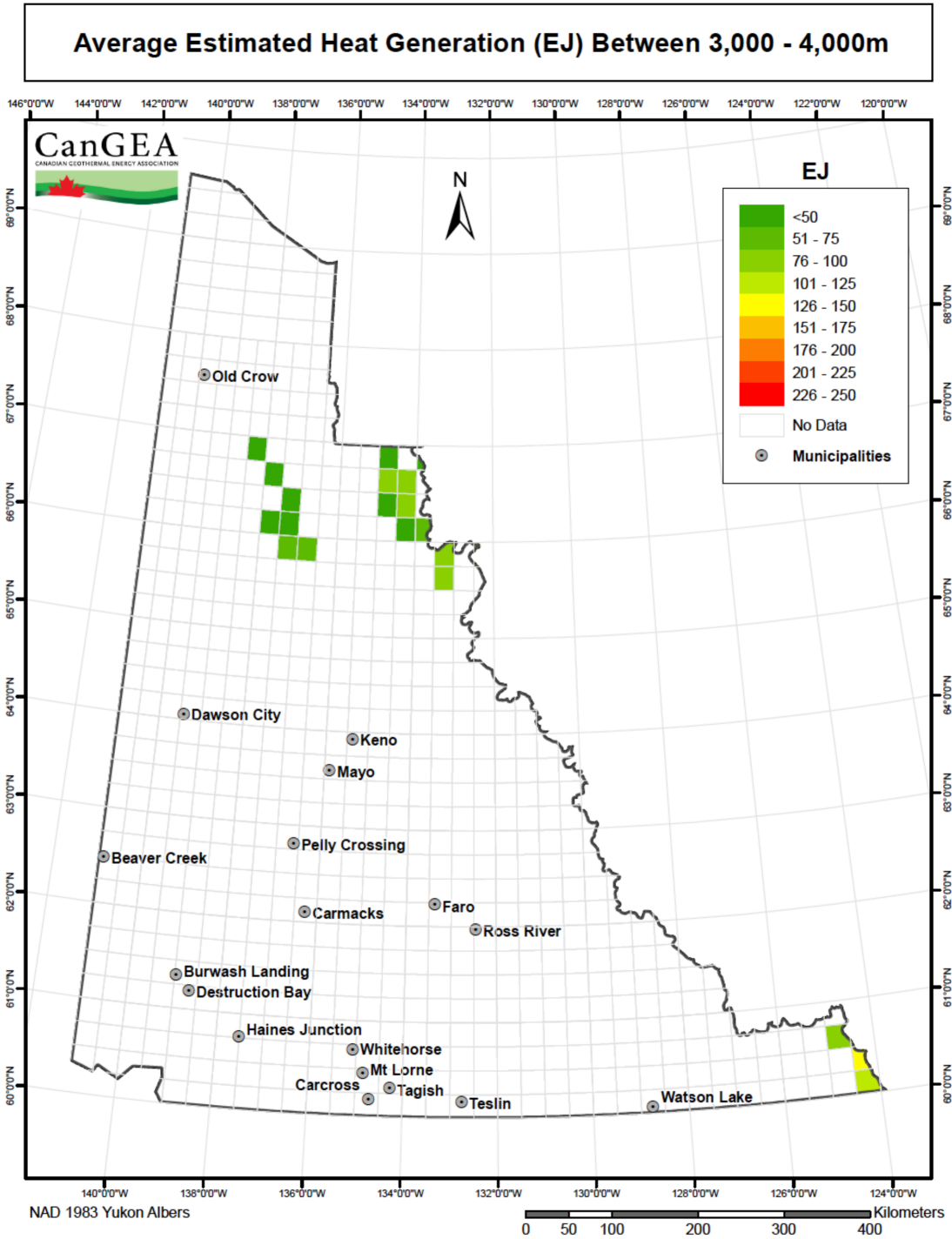

Figure 62: Average estimated heat generation – 3,000m – 4,000m

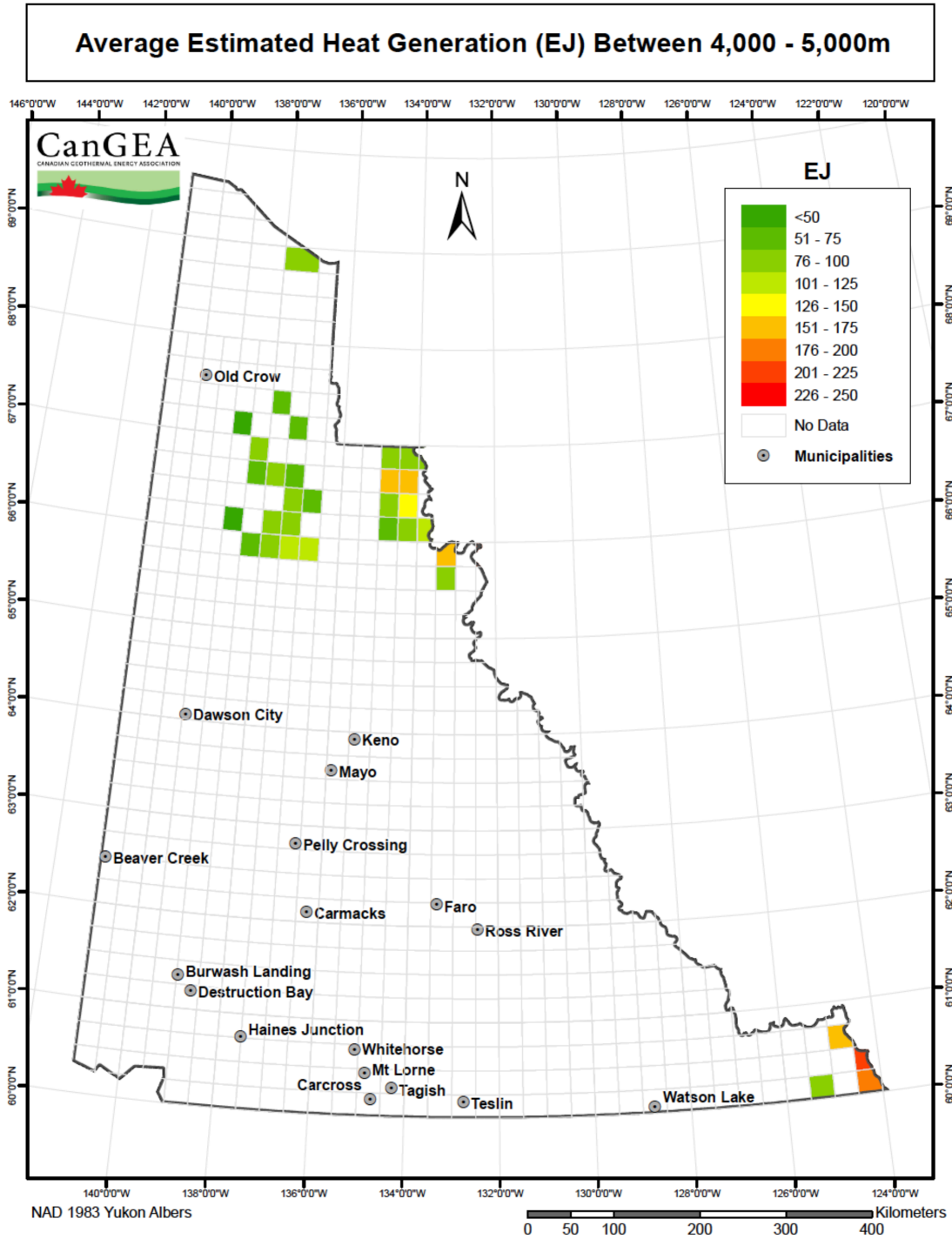

Figure 63: Average estimated heat generation – 4,000m – 5,000m

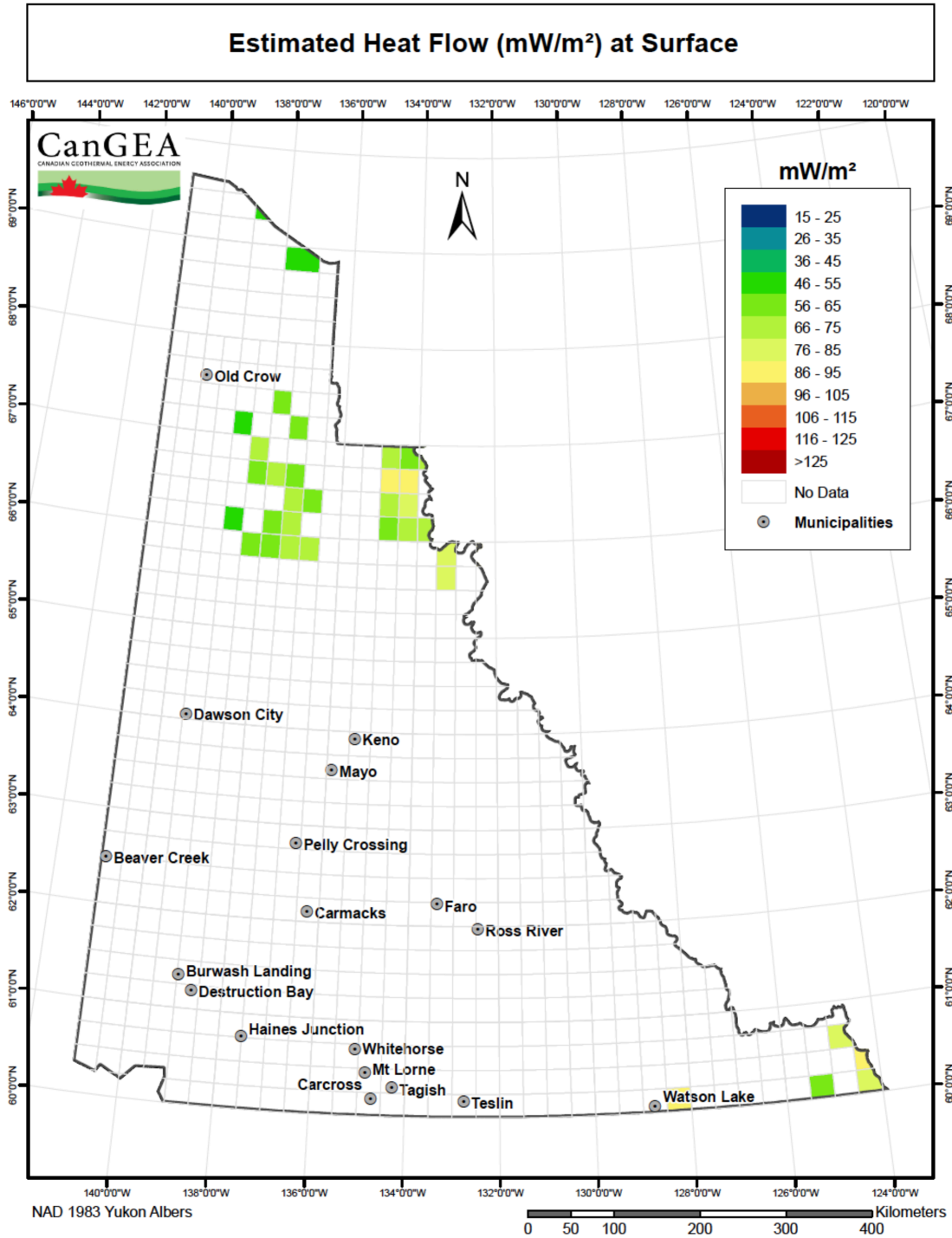

Figure 64: Estimated heat flow at surface



Yukon Community Investigation

Yukon Geothermal Energy Report
2016

Scope

The purpose of this section is to provide background information on communities in the Yukon. The following community profiles intend to aid geothermal developers in understanding each community in order to make informed decisions when pursuing a geothermal project in any of these localities. The profiles account for demographics, energy and commodity prices, proximity to other communities, infrastructure, and notable local industries. A total of 17 Yukon communities were profiled, and are included in the following alphabetical order:

1. Beaver Creek
2. Burwash Landing
3. Carcross
4. Carmacks
5. Dawson City
6. Destruction Bay
7. Faro
8. Haines Junction
9. Mayo
10. Mount Lorne
11. Old Crow
12. Pelly Crossing
13. Ross River
14. Tagish
15. Teslin
16. Watson Lake
17. Whitehorse

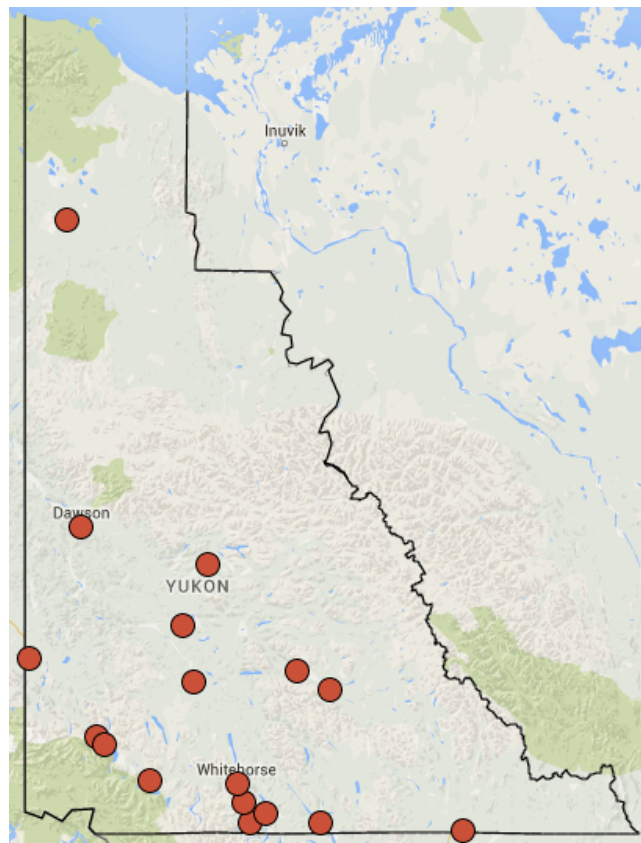

Location of all profiled communities, source: Google

Canadian Geothermal Energy Association
PO Box 1462 Station M, Calgary, Alberta, T2P 2L6, Canada
info@cangea.ca - www.cangea.ca



Geothermal Survey Results

CanGEA used primary research to find out the needs and desires of the local communities. The research was undertaken through an online survey and personal interviews throughout the year of 2015. The results of the survey show a clear trend in what people are concerned about: high food prices. Almost all participants were also concerned about the limited variety of fruits and vegetables that are available in their hometown. This is no surprise and can be found throughout many communities in similar climate conditions with the additional challenge of long transport routes for groceries. Desired uses of geothermal energy other than horticultural applications can be summarized as “affordable heating” for communal buildings and private homes. Geothermal heating can be undertaken in many ways and different types of buildings can be heated. The participants of the survey also expressed the desire to reduce the share of fossil fuel and improve the environmental impact of their communities.

Even though for some communities a district heating system is not economically viable, small-scale applications like heat pumps or a very localized small scale heating system might work. In such a system the heat would not necessarily be only used to heat residential homes. Workshops, community halls, schools, etc. can also be recipients of geothermal heat and would contribute greatly to the quality of life in the community by providing communally accessible space for leisure time activities. The individual responses to the online survey are not part of this report, but can be requested from CanGEA.

Beaver Creek

Overview

Beaver Creek is 3 hours north west of Haines Junction, 5 hours from Whitehorse along the Alaska Highway, and is located 22 km south of the Yukon-Alaska border crossing. It is home to the White River First Nation, which is culturally affiliated with both the Upper Tanana and the Northern Tutchone people. They are one of three Yukon First Nations that have not signed a land claims or self-government agreement. Beaver Creek's location near the Canada-US border makes it a popular stop for travelers.



Beaver Creek, source: Google

Demographics

Table 7: Beaver Creek 2011 demographics⁷⁷

Classification	Settlement	Percent of population over 15	79.5%
Population in 2011	103	Total private dwellings	76
Population in 2006	112	Private dwellings occupied by usual residents	52
2006 to 2011 population change	-8.0%	Land area	27.14 km ²
Median age	39.8	Population density	3.8 / km ²

Geothermal Potential

The exploration of the surrounding area of Beaver Creek led to the temperature exploration results as shown in the table below.

Table 8: Temperature at depth & technical geothermal potential in Beaver Creek

Depth in m	Temperature in °C	Technical Potential with 5% recovery in MW	Technical Potential with 14% recovery in MW	Technical Potential with 20% recovery in MW
1,500	37	-	-	-
2,500	63	-	-	-
3,500	88	4.18	11.70	16.72
4,500	112	4.68	13.61	19.44

The data suggests that Beaver Creek has high enough temperatures to produce electricity via a binary power plant. The current cut off temperature is reached below 2,500m. As Beaver Creek is an off-grid community that currently produces its electricity from diesel, a combined heat and power project might be valuable. A communal distribution grid exists and can be used for geothermally generated electricity.

The evaluation of project costs for Beaver Creek is not 100% accurate. CanGEA has undertaken calculations for binary power plant costs in the past and the results of these calculations are used in this report. The assumptions used for these calculations are not identical to the real local circumstances.

CanGEA’s internal research states the cost for a 1 MW_e/13 MW_t Combined Heat and Power (CHP) project set in a Wet Fractured Rock environment in the Canadian North to be roughly \$31 million. A cost table can be found in Table 9. The actual cost for Beaver Creek would likely be slightly higher, as the drilling depth is estimated to be deeper than in the calculatory example.

Table 9: Cost table for an exemplary 1 MW_e/13 MW_t CHP project in northern Canada (Wet Fractured Rock environment).

Cost Category	Cost in million \$
---------------	--------------------

Exploration and Drilling	18.0
Well Pumps	1.7
ORC Unit	4.0
Facility	2.6
Construction	0.8
Materials	0.7
Engineering	0.5
Contingency	2.8

Assuming a capacity factor of 0.9, the potential to sell all produced electricity (7,884,000 kWh/a), constant achievable prices, a project lifetime of 50 years, a Weighted Average Cost of Capital (WACC) of 8%, construction cost payable up front and disregarding annual maintenance cost, the break even price for power production only is approximately \$0.30/kWh. The break-even price can be lowered / the NPV can be increased by adding a cascaded heat system that could be used for additional profit generation.

It is assumed that the temperature of the geothermal fluid leaving the binary power plant will decrease by about 17 °C from the incoming fluid, as this has been the case for other binary power plants of similar size. The outlet geothermal fluid allows for further cascaded use of the fluid, which may be economically beneficial and is strongly suggested for Beaver Creek. Along with many other northern communities, district heating, horticulture and additional direct-use applications of geothermal energy may be economically viable for Beaver Creek.

Geothermal Greenhouses

Horticultural applications could create value by providing locally grown fruits and vegetables for consumption by the Beaver Creek community. Geothermal power can be used to not only heat a greenhouse, but also to supply the building with electricity for artificial lighting to assist in the optimal growth of plants. A greenhouse powered by geothermal energy could make a true year-round operation possible in Beaver Creek and support the community with fresh produce at any time of the year.



Only 37.3% of Yukon residents reported fruit and vegetable consumption of 5 or more times per day in 2008.⁷⁸ Initially, a design of a greenhouse powered by geothermal energy that could produce spinach all-year round for the population of Beaver Creek was considered. Spinach was chosen for this design as an example of what could be grown since it is a nutrient dense vegetable, with one serving providing nutrients that include 5% of a person’s daily iron and 56% of a person’s daily recommended vitamin A intake. It is also a versatile vegetable that can be worked into various meals or snacks, as well as eaten raw or frozen to be consumed at a later date.

The greenhouse is designed to provide fresh vegetables all year round to the Beaver Creek community during 7 harvests, since spinach takes approximately 8 weeks until it can be harvested. To yield one serving of spinach per day for each resident of Beaver Creek throughout the year a greenhouse would need to have approximately 1,259 sqft of growing area. This area does neither account for extra space needed to maneuver in the greenhouse nor for space for packaging and storing the produce. As it is assumed that the plants will take up 60% of the total greenhouse area, the final space needed for the operation of the greenhouse is 2,099 sqft. A harvest of this size would provide the possibility for each resident of Beaver Creek to consume fresh vegetables at least once per day. As the yield per square metre and the suggested serving size differ for each fruit and vegetable, the overall size of the greenhouse changes with its produce selection. In order to provide a serving of beets per day for every resident of Beaver Creek, the greenhouse would need a floor space of 3,272 sqft. Tomatoes can have a very high yield per square metre. Therefore it is suggested to add floor space to the greenhouse in order be able to supply fresh tomatoes on a regular basis to the residents of Beaver Creek. A growing area of 160 sqft should suffice to produce over 50 servings of tomatoes per resident each year. An overall size of approximately 2,400 sqft (1,440 sqft growing area) is suggested.

Table 10: Estimated possible vegetable production for 1,440 sqft of growing space (monoculture)

Product	Grams per 120m²	Grams per serving	Total servings per 120m²
Spinach	214,400	32.5	6,597
Tomato	6,700,000	137	49,630

Beets	301,500	71	4,246
-------	---------	----	-------

In cold climates, it is of importance to collect as much sunlight as possible while minimizing the negative effect that shadow has on crop growth. A length to width ratio of at least 2:1 is recommended while orienting the structure in an east-west direction. Due to the high latitude of any location within the Yukon the northern side of a greenhouse will not collect direct sunlight. The outer surfaces that are able to utilize the sun’s light and heat will be made of 3-wall polycarbonate as it can withstand high winds and a considerable snow load while offering good insulation values. The surfaces of the greenhouse that will not be in direct contact with the sunlight will be made of an aluminum frame with insulation between the inner and outer walls. This will further minimize heat loss, allowing for a more efficient heat management in the greenhouse. The whole frame of the greenhouse can be made out of aluminum, as it is the dominant material on the market. Aluminum offers multiple advantages over wood or steel, as it is longer lasting and relatively light. Additionally, the inclination on the south facing roof should be chosen in a way that maximizes the natural solar heat gain. For the Beaver Creek Greenhouse, a roof inclination of 45 degrees will be used to allow for this solar heat gain and easy removal of materials that may cover the roof such as snow.

With these design considerations in mind, a preliminary design for the greenhouse can be obtained, allowing for a rough cost estimate to be made. The greenhouse will be a long rectangular prism of 2:1 length to width with a triangular roof. This design coupled with a required floor space of 2,400 sqft produces a greenhouse with the following dimensions.

Table 11: Exemplary greenhouse design – Beaver Creek

Dimension	ft
Length	69
Width	35
Height of north/south wall	10
Height of peak	28

Table 12: Exemplary greenhouse design – surface areas - Beaver Creek

Dimension	sqft
South Wall	693
East Wall	832
West Wall	832
North Wall	693
South Roof	2,284
North Roof	2,284
Total	7,619

The east, west and south walls as well as the south facing roof will all be made out of 3-wall polycarbonate as they will be the walls capable of using the sun’s heat and light. The north wall and north facing roof will be made out of aluminum siding/roofing with layers of insulation on the inner walls of the material to reduce heat loss. Prices are averaged prices obtained by selective market research. Real prices in Beaver Creek can differ.

Table 13: Exemplary greenhouse design – material cost - Beaver Creek

Material	Amount (ft²)	Cost (\$/ft²)	Total cost (\$)
Aluminum framing	501	2.5	1,253
Polycarbonate	4,642	1.99	9,237
Insulation	2,977	1.5	4,466
Aluminum roofing	2,284	3.99	9,114
Total			24,070

In order for the greenhouse to be operational on a high level during the whole year, it must be able to maintain an inside temperature of minimum 15 °C while the outside temperature might drop to -27.5 °C, which is the estimated average low of the coldest month in Beaver Creek. In these conditions, a minimum heat rating of 46 kW is required. This will be provided from the power plant outlet stream. A 60 kW diesel generator on ¾ load would require 14.4 litres of diesel per hour to provide sufficient heating in these harsh conditions. This equates to 346 litres of diesel fuel per day, costing roughly \$394 at \$1.14/litre. These costs can be partially avoided by using geothermal energy. As temperatures can drop below the estimated average low, a backup heating system can be installed to avoid frost damage.

It is advisable to build the greenhouse in a location close to the binary power plant to ensure the geothermal fluid flowing from the plant to the greenhouse experiences minimal heat loss during the transport. This location should also be in close proximity to the community to allow for easy access and operation. If there is existing infrastructure near a suitable building site in Beaver Creek, the greenhouse could be attached to a building, which will reduce the initial construction costs of the greenhouse, as well as to minimize its heat loss.

The next steps in the design of the greenhouse are to decide on lighting and piping. The lighting system and the pipes should be laid out evenly in order to maintain a uniform heat distribution within the greenhouse. Depending on the ground area of the greenhouse, two inflow pipes should be used, which transport the water in alternating directions in order to minimize the effect the heat loss along the piping system has on the uniformity of the temperature distribution within the building. The minimum temperature of the greenhouse should not drop below 0°C. In order to minimize heat loss when entering the greenhouse, a heated arctic entry should be considered. When designing the pipe and lighting layout it is important that it is closely linked to the alignment of the crops being grown. Between crop rows, tracks need to be wide enough to ensure effective harvesting and allowing maintenance on the heating and lighting system.

The northern latitude of Beaver Creek results in widely varying daylight periods throughout the year. The longest day of the year averages approximately 18 hours long, and the shortest day of the year is roughly 5 hours long. This variation in daylight hours creates challenges for greenhouse operations in Beaver Creek, and the greenhouses must have an LED lighting system in place to accommodate for these varying amounts of sun. The lighting systems used in the Alaskan Chena Hot Springs greenhouses are designed specifically for each crop in order to be as energy efficient as possible. Similarly, greenhouses constructed in Beaver Creek should be energy conscious with their lighting system, using LED lighting for their energy efficiency, and to accommodate for fluctuating daylight hours throughout the year.

Due to the low soil temperatures in a northern environment like Beaver Creek, the use of raised planting beds is advisable. Additionally, raised beds can make harvesting the produce easier as the beds are raised to working level.

As plants need water and fertilizer for their growth, choices on irrigation systems and fertilizer selection have to be made. For Beaver Creek a fertigation system would be preferable, which means that a fertilizer water solution is used. This system works on a drip irrigation basis with added root moisture sensors, which ensure an optimal moisture and nutrient level at all times.

Ventilation systems offer effective temperature adjustment with little effort. It is advisable to install an automated system, which regulates the indoor temperature through automated opening and closing of vents.

During the heating process the temperature of the working fluid will decrease, though the remaining temperature is likely high enough to be used for further cascaded applications such as drying fresh food products, heated storage or other types of public facilities, district heating and the heating of public swimming pools. These applications that could be beneficial to Beaver Creek, in addition to being powered in an affordable and efficient way by geothermal power will be discussed in further detail below.

Drying of Greenhouse products

The drying of food is an application that is can be particularly meaningful to northern communities, since it is a way to preserve fruits and vegetables that are not abundant in these climates for future consumption. Though it is important to note that dried fruits and vegetables cannot replace their fresh versions since there is some nutrient loss caused by dehydration, these products can be used to supplement diets and have a high caloric density with dried fruits and vegetables containing up to five time more calories than their fresh counterparts. A food drying facility in Beaver Creek could use the excess heat that is available after heating the greenhouse to heat up the drying chamber. A de-humidifier and an air pump can be electrically powered and should be used in wet weather. Good primary drying conditions require a relative humidity between 20% and

50% and an air velocity of approximately 3 m/s. For perfect results a second drying process with higher temperatures and lower air velocity can be added.

Space heating

The dense settlement structure in part of Beaver Creek makes a district heating system a potentially attractive application for the community. Heat derived from the geothermal fluid flowing out of the power plant could provide a more affordable and environmental way to heat portions of the town. The small population size in contrast to the capital expense is a limiting factor for Beaver Creek.

Beaver Creek features several communal buildings that could be heated geothermally. In addition to e.g. the library, heated buildings could be used for community social events and storage. A space heated to room temperature could also be used in part for animal husbandry, more specifically the raising of chickens for eggs and meat throughout the winter. This could be an important endeavour for a community like Beaver Creek that cannot keep animals all year round outdoors due to its cold climate. Also, eggs, which are a source of protein, are substantially more expensive in Beaver Creek than in other parts of Canada.

Aquaculture

Different species of fish could be raised for human consumption all year round in Beaver Creek through the use of aquaculture powered and heated by geothermal energy.

Some examples of fish that are native to this region are Arctic grayling, northern pike and lake trout. For this example, an aquaculture system for the farming of rainbow trout, a commonly cultured fish that cannot already be found in Beaver Creek is suggested. Rainbow trout is a good source of protein with an average marketable size fish, between 0.5 to 1.0 kg and a good source of Omega-3 essential acids. Trout will exhibit optimum growth at 17°C, though they can survive between temperatures of 0°C to 27°C. This species of trout will take about 6 to 8 months to reach their optimal market size.

For fish of 500g in size, the tank should be able to maintain a flow through of 5 l/min/m³ and can produce about 50 fish per m³. For a community like Beaver Creek a reasonably large tank could be built and the fish produced could be frozen for later consumption or to be sold to nearby communities. To complete all steps of fish farming in Beaver Creek, hatching and rearing tanks will also need to be constructed. The location of Beaver Creek close to a freshwater source of the same name is ideal since this water could be used to fill the tanks in which to grow the trout.

General assumptions can be made about the piping that will be required for the heat exchanger and their location in relation to the tank. For example, steel or FRP (Fibreglass Reinforced Plastic) piping could be used to carry the hot fluid to and from the heat exchanger and PVC piping could be used to circulate the warm fluid through the tank. A method to reduce heat loss due to the cold northern temperatures and evaporation all year round from the tanks would be to cover them with a roof structure similar to that of a greenhouse and heat the space surrounding the tank.

One way to simplify the aquaculture system is to grow vegetation on the surface of the water that will enable some feeding of the trout, as well as to filter the water in the tanks. For example, numerous floating and rooted water plants could be grown on the surface of the water in the fish tanks, like duck weed, water lettuce, water hyacinth, water cress and water parsnip. The plants will reproduce naturally and survive off of nutrients in the water, sunlight and the carbon dioxide produced by the fish. In return, the plants oxygenate the water and could potentially be a source of food for the fish.

Geothermal heated swimming pool

There is already a swimming pool operating as part of the Beaver Creek Community Club. However, it only operates seasonally and Beaver Creek residents have expressed their desire for the pool to be opened all year round.

Swimming pools are normally heated to between 25 and 28 °C. Installing a geothermal heat exchanger to heat the pool to this temperature would be beneficial for the

community as it would provide another way for residents to exercise regularly in the winter months and is a measure to improve the quality of life in general.

Cost of Energy

Beaver Creek is an off-grid community; electricity is generated locally from a 0.9 MW diesel facility.

Table 14: Residential energy prices in Beaver Creek

	Residential Service, non-government ⁷⁹	Residential Service, government ⁸⁰
Customer charge	\$14.65	\$18.47
Energy charge for the first 1,000 kWh	12.14 ¢/kWh	16.47 ¢/kWh
Energy charge between 1,001 – 2,500 kWh	12.82 ¢/kWh	17.47 ¢/kWh
Energy charge for energy in excess of 2,500 kWh	13.99 ¢/kWh	18.85 ¢/kWh

Table 15: General service energy prices in Beaver Creek

	General Service, non-government ⁸¹	General Service, government - municipal ⁸²	General Service, government – federal & territorial ⁸³
Demand Charge for all kW of billing demand*	\$7.39 / kW	\$7.39 / kW	\$12.31 / kW
Energy charge for the first 2,000 kWh	10.00 ¢/kWh	10.00 ¢/kWh	13.81 ¢/kWh
Energy charge between 2,001 – 15,000 kWh	12.88 ¢/kWh	12.88 ¢/kWh	15.00 ¢/kWh
Energy charge between 15,001 – 20,000 kWh	15.68 ¢/kWh	15.68 ¢/kWh	20.00 ¢/kWh
Energy charge for energy in excess of 20,000 kWh	15.22 ¢/kWh	15.22 ¢/kWh	15.22 ¢/kWh

*where the billing demand may be estimated or measured and will be the greater of the following: A) The highest metered demand during the billing period. B) The highest metered demand during the 12 months ending with the current billing month, excluding the months April through September. C) The estimated demand. D) 5 kilowatts.

Table 16: Beaver Creek 2015 residential fuel prices⁸⁴

Month	Furnace Oil (¢/L)	Arctic Stove Oil (¢/L)	Propane (\$/500 gallon tank)
December	107.7	108.7	No Data
November	109.8	112.2	No Data
October	109.8	113.3	No Data
September	109.8	111.3	No Data
August	115.1	113.9	No Data
July	115.1	114.7	No Data
June	115.1	115.6	No Data
May	115.1	114.8	No Data
April	115.1	117.8	No Data
March	115.1	117.2	No Data
February	115.1	114.0	No Data
January	No Data	110.4	No Data

Infrastructure

Table 17: Beaver Creek infrastructure profile

List of Relevant Infrastructure	
Transportation Infrastructure	Tourism infrastructure
Highway access via Alaska Highway Gravel airstrip maintained year round	Hotels Restaurants RV park & campground
Communication Infrastructure	Emergency Services
Cell reception: Latitude Wireless High speed internet: NorthwesTel Landline phone service: NorthwesTel	Health Centre (1 nurse on staff) Volunteer Ambulance on call 24 hours Medevac available 24 hours for emergencies Volunteer Fire on call 24 hours RCMP detachment
Business Infrastructure	Housing Infrastructure
Canada Customs and Immigration station TD Bank Gas station Wilderness adventure outfitter There is no grocery store	76 Private dwellings 52 Normally occupied dwellings 40 Single detached houses 0 Apartments (5+ storeys) 0 Apartments (<5 storeys) 10 Movable dwellings 0 Semi-detached houses 0 Row houses 0 Duplexes
Educational Infrastructure	Recreation Infrastructure
Grade school up to grade 9 Community library	Community club Gym Swimming pool

Economics

Table 18: Beaver Creek 2015 Spatial Price Index (Whitehorse = 100)

Meat	No Data	Household Operations	No Data
Dairy/eggs	No Data	Health and Personal Care	No Data
Fruit/vegetables	No Data	Gasoline	No Data
Bread/cereal	No Data	Cigarettes	No Data
Other Foods	No Data	Total Survey Items	No Data

Industries

The Canadian Border Services Agency, territorial government, and First Nation administration provides much of the employment in Beaver Creek. May through September is the busy tourist season and the local lodges and restaurants also provide more employment. There is some mineral exploration in the region, which holds potential for further economic development and job creation. The Canalask mining project was last subject to exploration activity in 2008. Future development is possible. Many people in the community hunt, fish and trap for sustenance, securing a significant portion of their own food supply and income in this way.

Beaver Creek Diesel Facility

Beaver Creek is not connected to the main Yukon electric grid. Electricity in Beaver Creek is generated from a 0.9 MW diesel generator.⁸⁵ With 76 private dwellings and several businesses, within the settlement limits a similar sized binary geothermal combined heat and power unit could potentially provide all electric and district heating needs to the community. This would significantly reduce emissions from power and heat generation, and enable new business ventures, like year round greenhouses,



Beaver Creek visitor information centre, source: Yukon Government

Canadian Geothermal Energy Association
PO Box 1462 Station M, Calgary, Alberta, T2P 2L6, Canada
info@cangea.ca - www.cangea.ca



contributing to the local economy and food security of the community. Geothermal binary power plants that operate with an installed capacity of around 1 MW have been in operation in many countries and are a reliable source of electricity for the local municipalities. The economic assessment of small-scale binary power plants is of high importance as the cost per capita can be significant.

Burwash Landing

Overview

Burwash Landing is 1 hour northwest of Haines Junction, 3 hours from Whitehorse along the Alaska Highway, and is 17 km north west of Destruction Bay, of which it shares many services. Burwash Landing is home to the Kluane First Nations, the majority of the First Nation people in this area identify as Southern Tutchone. There is interest in renewable energy in Burwash Landing, but the geothermal potential is low.



Burwash Landing, source: Google

Table 19: Burwash Landing 2011 demographics⁸⁶

Classification	Settlement	Percent of population over 15	85.1%
Population in 2011	95	Total private dwellings	73
Population in 2006	73	Private dwellings occupied by usual residents	50
2006 to 2011 population change	+30.1%	Land area	30.09 km ²
Median age	41.5	Population density	3.2 / km ²

Geothermal Potential

Table 20: Temperature at depth & technical geothermal potential in Burwash Landing

Depth in m	Temperature in °C	Technical Potential with 5% recovery in MW	Technical Potential with 14% recovery in MW	Technical Potential with 20% recovery in MW
1,500	30	-	-	-
2,500	51	-	-	-
3,500	71	-	-	-

4,500	90	4.41	12.35	17.64
-------	----	------	-------	-------

With a temperature of 71°C at a depth of 3,500m the geothermal potential for Burwash Landing is limited. Binary power plants would require drilling to depths beyond 3,500m and are considered to have limited economic viability. This situation does not change when the neighbouring village of Destruction Bay is considered. Low temperature wells could be used for geoexchange applications and heat individual homes/businesses.

Space heating in such a low temperature surrounding is most likely to be economical via geothermal heat pumps. Burwash Landing has multiple communal buildings that are potential targets of geothermal heating, e.g. Jacquot Hall. The primary source for heating is currently biomass. Electricity is mainly produced from a diesel generator. Burwash Landing and Destruction Bay can be characterized as communities, which would benefit from any renewable energy project in their vicinity. Due to the very limited geothermal potential for power production and the low population count, Burwash Landing is not to be prioritized when it comes to geothermal development in the Yukon.

Using geothermal heat for horticulture applications seems possible in Burwash Landing and Destruction Bay and would supply the local population with an additional food source. Currently there is no grocery store in town and residents need to travel for fresh produce during the winter months. Greenhouses could help extending the local growing period and therefore help improving the supply of locally grown produce. Due to the low soil temperatures horticultural applications would likely have to rely on geoexchange systems that harvest the heat from shallow ground.

Horticultural applications could create value by providing locally grown fruits and vegetables for consumption by the Burwash Landing community. A greenhouse powered by geothermal energy could make a true year-round operation possible in Burwash Landing and support the community with fresh produce at any time of the year.

Only 37.3% of Yukon residents reported fruit and vegetable consumption of 5 or more times per day in 2008.⁸⁷ Initially, a design of a greenhouse powered by geothermal energy that could produce spinach all-year round for the population of Burwash Landing



was considered. Spinach was chosen for this design as an example of what could be grown since it is a nutrient dense vegetable, with one serving providing nutrients that include 5% of a person’s daily iron and 56% of a person’s daily recommended vitamin A intake. It is also a versatile vegetable that can be worked into various meals or snacks, as well as eaten raw or frozen to be consumed at a later date.

The greenhouse is designed to provide fresh vegetables all year round to the community during 7 harvests, since spinach takes approximately 8 weeks until it can be harvested. To yield one serving of spinach per day based on the Canada Food Guide, to each resident of Burwash Landing throughout the year a greenhouse would need to have approximately 1,163 sqft of growing area. This area does neither account for extra space needed to maneuver in the greenhouse nor for space for packaging and storing the produce. As it is assumed that the plants will take up 60% of the total greenhouse area, the final space needed for the operation of the greenhouse is 1,938 sqft. A harvest of this size would provide the possibility for each resident of Burwash Landing to consume fresh vegetables at least once per day. As the yield per square metre and the suggested serving size differ for each fruit and vegetable, the overall size of the greenhouse changes with its produce selection. In order to provide a serving of beets per day for every resident of Burwash Landing the greenhouse would need a floor space of 3,014 sqft. Tomatoes can have a very high yield per square metre. Therefore it is suggested to add floor space to the greenhouse in order be able to supply fresh tomatoes on a regular basis to the residents of Burwash Landing. A growing area of 160sqft should suffice to produce over 50 servings of tomatoes per resident each year. An overall size of 2,200 sqft (1,320 sqft growing area) is suggested.

Table 21: Estimated possible vegetable production for 1,320 sqft of growing space (monoculture)

Product	Grams per 108m ²	Grams per serving	Total servings per 108m ²
Spinach	196,800	32.5	6,055
Tomato	6,150,000	137	45,556
Beets	276,750	71	3,898

In cold climates, it is of importance to collect as much sunlight as possible while minimizing the negative effect that shadow has on crop growth. A length to width ratio of 146

at least 2:1 is recommended while orienting the structure in an east-west direction. Due to the high latitude of any location within the Yukon the northern side of a greenhouse will not collect direct sunlight. The outer surfaces that are able to utilize the sun’s light and heat will be made of 3-wall polycarbonate as it can withstand high winds and a considerable snow load while offering good insulation values. The surfaces of the greenhouse that will not be in direct contact with the sunlight will be made of an aluminum frame with insulation between the inner and outer walls. This will further minimize heat loss, allowing for a more efficient heat management in the greenhouse. The whole frame of the greenhouse can be made out of aluminum, as it is the dominant material on the market. Aluminum offers multiple advantages over wood or steel, as it is longer lasting and relatively light. Additionally, the inclination on the south facing roof should be chosen in a way that maximizes the natural solar heat gain. For the Burwash Landing Greenhouse, a roof inclination of 45 degrees will be used to allow for this solar heat gain and easy removal of materials that may cover the roof such as snow.

With these design considerations in mind, a preliminary design for the greenhouse can be obtained, allowing for a rough cost estimate to be made. The greenhouse will be a long rectangular prism of 2:1 length to width with a triangular roof. This design coupled with a required floor space of 2,200 sqft produces a greenhouse with the following dimensions.

Table 22: Exemplary greenhouse design – Burwash Landing

Dimension	ft
Length	66
Width	33
Height of north/south wall	10
Height of peak	27

Table 23: Exemplary greenhouse design – surface areas – Burwash Landing

Dimension	ft
South Wall	663
East Wall	777
West Wall	777
North Wall	663
South Roof	2,094

North Roof	2,094
Total	7,069

The east, west and south walls as well as the south facing roof will all be made out of 3-wall polycarbonate as they will be the walls capable of using the sun’s heat and light. The north wall and north facing roof will be made out of aluminum siding/roofing with layers of insulation on the inner walls of the material to reduce heat loss. Prices are averaged prices obtained by selective market research. Real prices in Beaver Creek can differ.

Table 24: Exemplary greenhouse design – material cost – Burwash Landing

Material	Amount (ft ²)	Cost (\$/ft ²)	Total cost (\$)
Aluminum framing	463	2.5	1,157
Polycarbonate	4,312	1.99	8,580
Insulation	2,757	1.5	4,136
Aluminum roofing	2,094	3.99	8,355
Total			22,228

In order for the greenhouse to be operational on a high level during the whole year, it must be able to maintain an inside temperature of minimum 15 °C while the outside temperature might drop to -27 °C, which is the estimated average low of the coldest month in Burwash Landing. In these conditions, a minimum heat rating of 42 kW is required. A 60 kW diesel generator on ¾ load would require 14.4 litres of diesel per hour to provide sufficient heating in these harsh conditions. This equates to 346 litres of diesel fuel per day, costing roughly \$394 at \$1.14/litre. These costs can be partially avoided by using geothermal energy. As temperatures can drop below the estimated average low, a backup heating system can be installed to avoid frost damage.

It is advisable to build the greenhouse in close proximity to the community to allow for easy access and operation. If there is existing infrastructure near a suitable building site in Beaver Creek, the greenhouse could be attached to a building, which will reduce the initial construction costs of the greenhouse, as well as to minimize its heat loss.

The next steps in the design of the greenhouse are to decide on lighting and piping. The lighting system and the pipes should be laid out evenly in order to maintain a uniform heat distribution within the greenhouse. Depending on the ground area of the greenhouse, two inflow pipes should be used, which transport the water in alternating directions in order to minimize the effect the heat loss along the piping system has on the uniformity of the temperature distribution within the building. The minimum temperature of the greenhouse should not drop below 0°C. In order to minimize heat loss when entering the greenhouse, a heated arctic entry should be considered. When designing the pipe and lighting layout it is important that it is closely linked to the alignment of the crops being grown. Between crop rows, tracks need to be wide enough to ensure effective harvesting and allowing maintenance on the heating and lighting system.

The northern latitude of Burwash Landing results in widely varying daylight periods throughout the year. The longest day of the year averages approximately 18 hours long, and the shortest day of the year is roughly 5 hours long. This variation in daylight hours creates challenges for greenhouse operations in Burwash Landing, and the greenhouses must have an LED lighting system in place to accommodate for these varying amounts of sun. The lighting systems used in the Alaskan Chena Hot Springs greenhouses are designed specifically for each crop in order to be as energy efficient as possible. Similarly, greenhouses constructed in Burwash Landing should be energy conscious with their lighting system, using LED lighting for their energy efficiency, and to accommodate for fluctuating daylight hours throughout the year.

Due to the low soil temperatures in a northern environment like Burwash Landing, the use of raised planting beds is advisable. Additionally, raised beds can make harvesting the produce easier as the beds are raised to working level.

As plants need water and fertilizer for their growth, choices on irrigation systems and fertilizer selection have to be made. For Burwash Landing a fertigation system would be preferable, which means that a fertilizer water solution is used. This system works on a drip irrigation basis with added root moisture sensors, which ensure an optimal moisture and nutrient level at all times.

Ventilation systems offer effective temperature adjustment with little effort. It is advisable to install an automated system, which regulates the indoor temperature through automated opening and closing of vents.

The use of automated systems poses a substantial cost factor. These costs can be avoided by using simpler mechanisms.

Cost of Energy

Burwash Landing is an off-grid community; electricity is generated from a 0.9 MW diesel facility that powers both Burwash Landing and the nearby community of Destruction Bay.⁸⁸

Table 25: Residential energy prices in Burwash Landing

	Residential Service, non-government ⁸⁹	Residential Service, government ⁹⁰
Customer charge	\$14.65	\$18.47
Energy charge for the first 1,000 kWh	12.14 ¢/kWh	16.47 ¢/kWh
Energy charge between 1,001 – 2,500 kWh	12.82 ¢/kWh	17.47 ¢/kWh
Energy charge for energy in excess of 2,500 kWh	13.99 ¢/kWh	18.85 ¢/kWh

Table 26: General service energy prices in Burwash Landing

	General Service, non-government ⁹¹	General Service, government - municipal ⁹²	General Service, government – federal & territorial ⁹³
Demand Charge for all kW of billing demand*	\$7.39 / kW	\$7.39 / kW	\$12.31 / kW
Energy charge for the first 2,000 kWh	10.00 ¢/kWh	10.00 ¢/kWh	13.81 ¢/kWh
Energy charge between 2,001 – 15,000 kWh	12.88 ¢/kWh	12.88 ¢/kWh	15.00 ¢/kWh
Energy charge between 15,001 – 20,000 kWh	15.68 ¢/kWh	15.68 ¢/kWh	20.00 ¢/kWh
Energy charge for energy in excess of 20,000 kWh	15.22 ¢/kWh	15.22 ¢/kWh	15.22 ¢/kWh

*where the billing demand may be estimated or measured and will be the greater of the following: A) The highest metered demand during the billing period. B) The highest metered demand during the 12 months ending with the current billing month, excluding the months April through September. C) The estimated demand. D) 5 kilowatts.

Table 27: Burwash Landing 2015 residential fuel prices⁹⁴

Month	Furnace Oil (¢/L)	Arctic Stove Oil (¢/L)	Propane (\$/500 gallon tank)
December	104.0	107.4	No Data
November	106.9	110.3	No Data
October	106.9	110.1	No Data
September	109.5	108.8	No Data
August	116.0	112.0	No Data
July	116.0	112.8	No Data
June	116.0	113.7	No Data
May	111.3	113.8	No Data
April	116.0	114.7	No Data
March	118.4	115.3	No Data
February	116.0	112.1	No Data
January	120.8	110.4	No Data

Infrastructure

Table 28: Burwash Landing infrastructure profile

List of Relevant Infrastructure	
Transportation Infrastructure	Tourism infrastructure
Highway access via Alaska Highway Gravel airstrip maintained year round	Hotels Restaurants Campground
Communication Infrastructure	Emergency Services
Cell reception: Latitude Wireless High speed internet: NorthwesTel Landline phone service: NorthwesTel	Health Centre in Destruction Bay Volunteer Ambulance in Destruction Bay Medevac available 24 hours for emergencies RCMP detachment in Haines Junction
Business Infrastructure	Housing Infrastructure
Post Office TD Bank KCDC Community Development Corporation	73 Private dwellings 50 Normally occupied dwellings 45 Single detached houses 0 Apartments (5+ storeys) 0 Apartments (<5 storeys) 5 Movable dwellings 0 Semi-detached houses

	5 Row houses 5 Duplexes
Educational Infrastructure	Recreation Infrastructure
Grade school up to grade 8 in Destruction Bay Library in rear of Jacquot Building	Community recreation centre (under construction) Indoor ice rink Weight room Jacquot Hall

Economics

Table 29: Burwash Landing 2015 Spatial Price Index (Whitehorse = 100)

Meat	No Data	Household Operations	No Data
Dairy/eggs	No Data	Health and Personal Care	No Data
Fruit/vegetables	No Data	Gasoline	No Data
Bread/cereal	No Data	Cigarettes	No Data
Other Foods	No Data	Total Survey Items	No Data

Industries

The Kluane Community Development Corporation (KCDC) supports community development projects, research and business case preparation, management of community based businesses, provides entrepreneurial support, and fundraising and proposal writing for all Yukon Economic Development and Corporate initiatives. Tourism is also a major economic driver in the community between the months of May to September. Some tourism facilities remain open year round. There is no grocery store in Burwash Landing, and many residents secure a significant portion of their food supply from hunting, fishing, and trapping.

Wind Energy in Burwash Landing

Burwash landing is not connected to the main Yukon electric grid. A 0.9MW diesel generator provides electricity to both Burwash Landing and Destruction Bay. Burwash landing does have a small but welcoming history with renewable energy development. There are plans underway for the Kluane Wind-Diesel Project to establish a small wind farm near the old rifle range. It could potentially produce 570,000 kWh/yr, offsetting up to

30% of diesel electricity. 590,000 litres of diesel fuel are consumed annually between Destruction Bay and Burwash, and this project is looking to offset as much as 160,000 litres of diesel fuel per year.⁹⁵

Solar Energy in Burwash Landing

There is one building in Burwash landing that has installed a photovoltaic (PV) system on the roof with four more PV systems expected on other KFN buildings this year. The existing system/owner is now a client of the YG Micro-generation Program and receives annual reimbursement (at a rate of 21¢/kWh) for all energy exported to the grid which is a small isolated diesel grid owned by ATCO Electric Yukon.

District Heating in Burwash Landing

There is a small district heating system installed in Burwash Landing. Four community buildings are supplied with hot water from a central boiler fuelled by woodchips harvested from Aboriginal lands. Benefits to the community include savings in operating budget as well as non-tangible benefits such as reduced reliance on outside fuel supplies and fluctuating prices.⁹⁶

Burwash Landing Energy Summary

Burwash Landing is a small but progressive community. “There is a real entrepreneurial spirit with the people of Burwash Landing; people use technology to work with organizations outside of the community, construction services are growing and still others have used great innovation to create their own place in the economy of the area.” – Math’eiya Alatini, Chief Kluane First Nation. The Kluane First Nation 2013-2016 strategy mandate includes the following key actions to their first strategic priority⁹⁷:

- Continuation of the community food security project
- Continue to work on the community renewable energy project
- Create infrastructure and supports for entrepreneurs and business development

The community’s interest in renewables and efforts in energy and food security make Burwash Landing a community to consider for future geothermal energy development. Additionally, Burwash Landing is located in an area with very low average winter temperatures. Currently the primary heating source is biomass.

Wellgreen Mine

The Wellgreen project, owned by Wellgreen Platinum Ltd. is located in close proximity to Burwash Landing. The platinum group metal (PGM) and nickel deposit of the area has enormous exploitation potential as the resources are located along the Alaska Highway and therefore road accessible, although 14km of the access road need to be updated. Additionally the seaports of Skagway and Haines in Alaska pose as close-by export hubs. The mine has been quoted to have the potential to become the second largest PGM and third largest Nickel sulphide producer outside of Russia and Africa. The territorial government and the Kluane First Nation have been involved in the project and declared general support for it. The project is currently in a pre-feasibility stage and it is not foreseeable when the project will transition to the development phase. The infrastructural features of the mine would be a large-scale electricity consumer. Electricity supply is planned via a LNG plant.

Table 30: Wellgreen mine based on preliminary economic assessment – February 2015⁹⁸

Ownership	100% Wellgreen Platinum Ltd.
Resource	329.6 million tonnes (varying % o
Primary Metals	Copper, gold and silver
End Products	PGM
Mine Type	Open pit (some zones might be suitable for underground mining)
Mine Life	25+ years
Employees	250+ (peak production), 580+ (peak construction)
Location	30 km NW of Burwash Landing, YT – 400 km N of year round port at Skagway, AK
Infrastructure	Good road access, upgrade of a 14km access road
Power	LNG plant (to be constructed)
Status	Feasibility Study

Carcross

Overview

Carcross is just 77 km south of Whitehorse along the Klondike Highway, and is 33 km west of Tagish. Carcross is a 2-hour drive from a year round port in Skagway, Alaska. It is home to the Carcross/Tagish First Nation (CTFN). The CTFN is a flourishing Self-Governing First Nation that has maintained strong ties to the land, as well as their traditions and culture. Carcross is a popular tourist destination in Yukon, known for its natural beauty and access to outdoor adventure sports.



Carcross, source: Google

Demographics

Table 31: Carcross 2011 demographics⁹⁹

Classification	Settlement	Percent of population over 15	84.1%
Population in 2011	289	Total private dwellings	198
Population in 2006	280	Private dwellings occupied by usual residents	143
2006 to 2011 population change	+3.2%	Land area	16.14 km ²
Median age	43.2	Population density	17.9 / km ²

Geothermal Potential

Table 32: Temperature at depth & technical geothermal potential in Carcross

Depth in m	Temperature in °C	Technical Potential with 5% recovery in MW	Technical Potential with 14% recovery in MW	Technical Potential with 20% recovery in MW
1,500	51	-	-	-

2,500	85	3.85	10.78	15.40
3,500	118	5.41	15.15	21.64
4,500	139	6.02	16.86	24.08

The temperatures surrounding Carcross suggest a fairly warm underground for Yukon standards and make the area an exceptionally good location for geothermal project development. The temperatures exceed 75°C between 1,500 and 2,500m depth. Therefore electricity production through a binary power plant is possible with limited drilling costs. Nevertheless, Carcross is part of the main hydroelectric grid and does not seem to need further power generating infrastructure.

The evaluation of project costs for Carcross is not 100% accurate. CanGEA has undertaken calculations for binary power plant costs in the past and the results of these calculations are used in this report. The assumptions used for these calculations are not identical to the real local circumstances.

CanGEA's archive states the cost for a 1 MW_e/13 MW_t CHP project set in a Hot Sedimentary Aquifer environment in the Canadian North with a drilling depth of 3,500m to be roughly \$28 million. A cost table can be found in Table 33. The actual cost for Carcross would be lower, as the drilling depth would stay below 2,500m.

Table 33: Cost table for an exemplary 1 MW_e/13 MW_t CHP project in northern Canada (HSA environment).

Cost Category	Cost in million \$
Exploration and Drilling	15.6
Well Pumps	1.7
ORC Unit	4.0
Facility	2.6
Construction	0.8
Materials	0.7
Engineering	0.4
Contingency	2.6

Assuming a capacity factor of 0.9, the potential to sell all produced electricity (7,884,000 kWh/a), constant achievable prices, a project lifetime of 50 years, a Weighted Average Cost of Capital (WACC) of 8%, construction cost payable up front and disregarding

Canadian Geothermal Energy Association
PO Box 1462 Station M, Calgary, Alberta, T2P 2L6, Canada
info@cangea.ca - www.cangea.ca



annual maintenance cost, the break even price for power production only is approximately \$0.27/kWh. The break-even price for Carcross would be slightly lower, since the drilling cost would be not as high as in CanGEOA's archived example. If 2,500m drilling depth with an assumed cost of \$11.1 million are used, the break-even price drops to roughly \$0.23/kWh. The break-even price can be lowered / the NPV can be increased by adding a cascaded heat system that could be used for additional profit generation.

As additional electricity is currently being supplied by the hydroelectric grid, the construction of a geothermal power plant is questionable. Nevertheless heat extraction from the ground seems to be a valuable option for this community and can be pursued at a much lower cost than power production.

In the case of Carcross, the HSA zone is exploitable at a depth of up to roughly 2,500m.

Geothermal Greenhouses

Horticultural applications could create value by providing locally grown fruits and vegetables for consumption by the Carcross community. Geothermal power can be used to not only heat a greenhouse, but also to supply the building with electricity for artificial lighting to assist in the optimal growth of plants. A greenhouse powered by geothermal energy could make a true year-round operation possible in Carcross and support the community with fresh produce at any time of the year.

Only 37.3% of Yukon residents reported fruit and vegetable consumption of 5 or more times per day in 2008.¹⁰⁰ Initially, a design of a greenhouse powered by geothermal energy that could produce spinach all-year round for the population of Carcross was considered. Spinach was chosen for this design as an example of what could be grown since it is a nutrient dense vegetable, with one serving providing nutrients that include 5% of a person's daily iron and 56% of a person's daily recommended vitamin A intake. It is also a versatile vegetable that can be worked into various meals or snacks, as well as eaten raw or frozen to be consumed at a later date.

The greenhouse is designed to provide fresh vegetables all year round to the Carcross community during 7 harvests, since spinach takes about 8 weeks until it can be harvested. To yield one servings of spinach per day, based on the Canada Food Guide, to each resident of Carcross over a three week long period after each harvest a greenhouse would need to have approximately 1,324 sqft of growing area. This area does neither account for extra space needed to maneuver in the greenhouse nor for space for packaging and storing the produce. As it is assumed that the plants will take up 60% of the total greenhouse area, the final space needed for the operation of the greenhouse is 2,207 sqft. A harvest of this size would provide the possibility for each resident of Carcross to consume fresh vegetables at least once per day during three weeks following each harvest. As the yield per square metre and the suggested serving size differ for each fruit and vegetable, the overall size of the greenhouse changes with its produce selection. In order to provide a serving of beets per day for every resident of Carcross the greenhouse would need a floor space of 3,444 sqft. Tomatoes can have a very high yield per square metre. Therefore it is suggested to add floor space to the greenhouse in order be able to supply fresh tomatoes on a regular basis to the residents of Carcross. A growing area of 220 sqft should suffice to produce over 25 servings of tomatoes per resident each year. An overall size of 2,400 sqft (1,440 sqft growing area) is suggested.

Tomatoes and beets have a similar growth time to spinach, are also nutrient dense and could be cultivated during another one of the 6 possible annual harvest periods in this greenhouse. A 2,400 sqft greenhouse could lead to the cultivation of tomatoes or beets and would have a positive impact on food security in the community.

Table 34: Estimated vegetable production for 1,440 sqft of growing space - Carcross

Product	Grams per 1,440 sqft	Grams per serving	Total servings per 1,440 sqft
Spinach	214,400	32.5	6,597
Tomato	6,700,000	137	49,630
Beets	301,500	71	4,246

In cold climates, it is of importance to collect as much sunlight as possible while minimizing the negative effect that shadow has on crop growth. A length to width ratio of 158

at least 2:1 is recommended while orienting the structure in an east-west direction. Due to the high latitude of any location within the Yukon the northern side of a greenhouse will not collect direct sunlight. The outer surfaces that are able to utilize the sun’s light and heat will be made of 3-wall polycarbonate as it can withstand high winds and a considerable snow load while offering good insulation values. The surfaces of the greenhouse that will not be in direct contact with the sunlight will be made of an aluminum frame with insulation between the inner and outer walls. This will further minimize heat loss, allowing for a more efficient heat management in the greenhouse. The whole frame of the greenhouse can be made out of aluminum, as it is the dominant material on the market. Aluminum offers multiple advantages over wood or steel, as it is longer lasting and relatively light. Additionally, the inclination on the south facing roof should be chosen in a way that maximizes the natural solar heat gain. For the Carcross Greenhouse, a roof inclination of 45 degrees will be used to allow for this solar heat gain and easy removal of materials that may cover the roof such as snow.

With these design considerations in mind, a preliminary design for the greenhouse can be obtained, allowing for a rough cost estimate to be made. The greenhouse will be a long rectangular prism of 2:1 length to width with a triangular roof. This design coupled with a required floor space of 2,400 sqft produces a greenhouse with the following dimensions.

Table 35: Exemplary greenhouse design – Carcross

Dimension	ft
Length	69
Width	25
Height of north/south wall	10
Height of peak	28

Table 36: Exemplary greenhouse design – surface areas - Carcross

Dimension	ft
South Wall	693
East Wall	832
West Wall	832
North Wall	693
South Roof	2,284

North Roof	2,284
Total	7,619

The east, west and south walls as well as the south facing roof will all be made out of 3-wall polycarbonate as they will be the walls capable of using the sun’s heat and light. The north wall and north facing roof will be made out of aluminum siding/roofing with layers of insulation on the inner walls of the material to reduce heat loss. Prices are averaged prices obtained by selective market research. Real prices in Carcross can differ.

Table 37: Exemplary greenhouse design – material cost - Carcross

Material	Amount (ft ²)	Cost (\$/ft ²)	Total cost (\$)
Aluminum framing	501	2.5	1,253
Polycarbonate	4,642	1.99	9,237
Insulation	2,977	1.5	4,466
Aluminum roofing	2,284	3.99	9,114
Total			24,070

In order for the greenhouse to be operational during the whole year, it must be able to maintain an inside temperature of minimum 15 °C while the outside temperature is -23 °C, which is the estimated average low for the coldest month in Carcross. In these conditions, a minimum heat rating of 41 kW is required. A 60 kW diesel generator on ¾ load would require 14.4 litres of diesel per hour to provide sufficient heating in these harsh conditions. This equates to 346 litres of diesel fuel per day, costing roughly \$394 at \$1.14/litre. These costs can be partially avoided by using geothermal energy. As temperatures can drop below the estimated average low, a backup heating system can be installed to avoid frost damage.

It is advisable to build the greenhouse in close proximity to the community to allow for easy access and operation. If there is existing infrastructure near a suitable building site in Carcross, the greenhouse could be attached to a building, which will reduce the initial construction costs of the greenhouse, as well as to minimize its heat loss.

The next steps in the design of the greenhouse are to decide on lighting and piping. The lighting system and the pipes should be laid out evenly in order to maintain a uniform heat distribution within the greenhouse. Depending on the ground area of the greenhouse, two inflow pipes should be used, which transport the water in alternating directions in order to minimize the effect the heat loss along the piping system has on the uniformity of the temperature distribution within the building. The minimum temperature of the greenhouse should not drop below 0°C. In order to minimize heat loss when entering the greenhouse, a heated arctic entry should be considered. When designing the pipe and lighting layout it is important that it is closely linked to the alignment of the crops being grown. Between crop rows, tracks need to be wide enough to ensure effective harvesting and allowing maintenance on the heating and lighting system.

The northern latitude of Carcross results in widely varying daylight periods throughout the year. The longest day of the year averages approximately 18 hours long, and the shortest day of the year is roughly 5 hours long. This variation in daylight hours creates challenges for greenhouse operations in Carcross, and the greenhouses must have an LED lighting system in place to accommodate for these varying amounts of sun. The lighting systems used in the Alaskan Chena Hot Springs greenhouses are designed specifically for each crop in order to be as energy efficient as possible. Similarly, greenhouses constructed in Carcross should be energy conscious with their lighting system, using LED lighting for their energy efficiency, and to accommodate for fluctuating daylight hours throughout the year.

Due to the low soil temperatures in a northern environment like Carcross, the use of raised planting beds is advisable. Additionally, raised beds can make harvesting the produce easier as the beds are raised to working level.

As plants need water and fertilizer for their growth, choices on irrigation systems and fertilizer selection have to be made. For Carcross a fertigation system would be preferable, which means that a fertilizer water solution is used. This system works on a drip irrigation basis with added root moisture sensors, which ensure an optimal moisture and nutrient level at all times.

Ventilation systems offer effective temperature adjustment with little effort. It is advisable to install an automated system, which regulates the indoor temperature through automated opening and closing of vents.

The remaining temperature after the greenhouse heating could be used for further cascaded applications such as drying fresh food products, heated storage or other types of public facilities, district heating and the heating of public swimming pools. These applications that could be beneficial to Carcross, in addition to being powered in an affordable and efficient way by geothermal power will be discussed in further detail below.

Drying of Greenhouse products

The drying of food is an application that is can be particularly meaningful to northern communities, since it is a way to preserve fruits and vegetables that are not abundant in these climates for future consumption. Though it is important to note that dried fruits and vegetables cannot replace their fresh versions since there is some nutrient loss caused by dehydration, these products can be used to supplement diets and have a high caloric density with dried fruits and vegetables containing up to five times more calories than their fresh counterparts. A food drying facility in Carcross could use the excess heat that is available after heating the greenhouse to heat up the drying chamber. A de-humidifier and an air pump can be electrically powered and should be used in wet weather. Good primary drying conditions require a relative humidity between 20% and 50% and an air velocity of approximately 3 m/s. For perfect results a second drying process with higher temperatures and lower air velocity can be added.

Space heating

The dense settlement structure in part of Carcross makes a district heating system a potentially attractive application for the community. Geothermal energy could provide a more affordable and environmental way to heat the portions of the town.

Carcross could also be home to geothermally heated community buildings that could be used for community social events and storage, among many other potential uses. A space heated to room temperature could be used in part for animal husbandry, more specifically the raising of chickens for eggs and meat throughout the winter. This could be an important endeavour for a community like Carcross that cannot keep animals all year round outdoors due to its cold climate.

Aquaculture

Different species of fish could be raised for human consumption all year round in Carcross through the use of aquaculture powered and heated by geothermal energy.

Some examples of fish that are native to this region are Arctic grayling, northern pike and lake trout. For this example, an aquaculture system for the farming of rainbow trout, a commonly cultured fish that cannot already be found in Carcross is suggested. Rainbow trout is a good source of protein with an average marketable size fish, between 0.5 to 1.0 kg and a good source of Omega-3 essential acids. Trout will exhibit optimum growth at 17°C, though they can survive between temperatures of 0°C to 27°C. This species of trout will take about 6 to 8 months to reach their optimal market size.

For fish of 500g in size, the tank should be able to maintain a flow through of 5 l/min/m³ and can produce about 50 fish per m³. For a community like Carcross a reasonably large tank could be built and the fish produced could be frozen for later consumption or to be sold to nearby communities. To complete all steps of fish farming in Carcross, hatching and rearing tanks will also need to be constructed. The location of Carcross close to a freshwater source is ideal since this water could be used to fill the tanks in which to grow the trout.

General assumptions can be made about the piping that will be required for the heat exchanger and their location in relation to the tank. For example, steel or FRP (Fibreglass Reinforced Plastic) piping could be used to carry the hot fluid to and from the heat exchanger and PVC piping could be used to circulate the warm fluid through the tank. A method to reduce heat loss due to the cold northern temperatures and

evaporation all year round from the tanks would be to cover them with a roof structure similar to that of a greenhouse and heat the space surrounding the tank

One way to simplify the aquaculture system is to grow vegetation on the surface of the water that will enable some feeding of the trout, as well as to filter the water in the tanks. For example, numerous floating and rooted water plants could be grown on the surface of the water in the fish tanks, like duck weed, water lettuce, water hyacinth, water cress and water parsnip. The plants will reproduce naturally and survive off of nutrients in the water, sunlight and the carbon dioxide produced by the fish. In return, the plants oxygenate the water and could potentially be a source of food for the fish.

Geothermal heated swimming pool

There is already a swimming pool operating in Carcross. However, it only operates seasonally and Carcross residents have expressed their desire for the pool to be opened all year round.

During the summer when the pool is open, it is heated by propane fired boilers. This system also heats the changing rooms, showers and mechanical room at the pool. Swimming pools are normally heated to between 25 and 28 °C. Installing a geothermal heat exchanger to heat the pool to this temperature could substitute the use of propane completely.

Having the pool operate year round through the use of geothermal energy would be beneficial for the community as it would provide another way for residents to exercise regularly in the winter months and is a measure to improve the quality of life in general.

Cost of Energy

Table 38: Residential energy prices in Carcross

	Residential Service, non-government ¹⁰¹	Residential Service, government ¹⁰²
Customer charge	\$14.65	\$18.47
Energy charge for the first	12.14 ¢/kWh	16.47 ¢/kWh

1,000 kWh		
Energy charge between 1,001 – 2,500 kWh	12.82 ¢/kWh	17.47 ¢/kWh
Energy charge for energy in excess of 2,500 kWh	13.99 ¢/kWh	18.85 ¢/kWh

Table 39: General service energy prices in Carcross

	General Service, non-government¹⁰³	General Service, government - municipal¹⁰⁴	General Service, government – federal & territorial¹⁰⁵
Demand Charge for all kW of billing demand*	\$7.39 / kW	\$7.39 / kW	\$12.31 / kW
Energy charge for the first 2,000 kWh	10.00 ¢/kWh	10.00 ¢/kWh	13.81 ¢/kWh
Energy charge between 2,001 – 15,000 kWh	12.88 ¢/kWh	12.88 ¢/kWh	15.00 ¢/kWh
Energy charge between 15,001 – 20,000 kWh	15.68 ¢/kWh	15.68 ¢/kWh	20.00 ¢/kWh
Energy charge for energy in excess of 20,000 kWh	12.86 ¢/kWh	12.86 ¢/kWh	12.86 ¢/kWh

*where the billing demand may be estimated or measured and will be the greater of the following: A) The highest metered demand during the billing period. B) The highest metered demand during the 12 months ending with the current billing month, excluding the months April through September. C) The estimated demand. D) 5 kilowatts.

Table 40: Carcross 2015 residential fuel prices¹⁰⁶

Month	Furnace Oil (¢/L)	Arctic Stove Oil (¢/L)	Propane (\$/500 gallon tank)
December	100.9	104.0	No Data
November	103.0	107.6	No Data
October	103.0	107.6	No Data
September	103.0	105.6	No Data
August	108.3	108.2	No Data
July	108.3	109.1	No Data
June	108.3	109.9	No Data
May	108.3	111.0	No Data
April	108.3	111.4	No Data
March	108.3	112.6	No Data
February	108.3	109.9	No Data
January	No Data	109.1	No Data

Infrastructure

Table 41: Carcross infrastructure profile

List of Relevant Infrastructure	
Transportation Infrastructure	Tourism infrastructure
Highway access via Kondike Highway	Hotels
Local airstrip	Restaurants
77km to Whitehorse International Airport	RV park & campground
Communication Infrastructure	Emergency Services
Cell reception: Latitude Wireless	Health Centre (2 nurses on staff)
High speed internet: NorthwesTel	Volunteer Ambulance on call 24 hours
Landline phone service: NorthwesTel	Medevac available 24 hours for emergencies
	Volunteer Fire on call 24 hours
	RCMP shared with Tagish
Business Infrastructure	Housing Infrastructure
Carcross Tagish Management Corporation	198 Private dwellings
Library	143 Normally occupied dwellings
Grocery store	120 Single detached houses
Post office	0 Apartments (5+ storeys)
1 hour drive to Whitehorse with all services	5 Apartments (<5 storeys)
	5 Movable dwellings
	10 Semi-detached houses
	10 Row houses
	0 Duplexes
Educational Infrastructure	Recreation Infrastructure
Grade school up to grade 9	Summer swimming pool
Yukon College Carcross Campus	Community Center
Community library	Weight Room

Economics

Table 42: Carcross 2015 Spatial Price Index (Whitehorse = 100)

Meat	No Data	Household Operations	No Data
Dairy/eggs	No Data	Health and Personal Care	No Data
Fruit/vegetables	No Data	Gasoline	No Data
Bread/cereal	No Data	Cigarettes	No Data
Other Foods	No Data	Total Survey Items	No Data

Canadian Geothermal Energy Association
PO Box 1462 Station M, Calgary, Alberta, T2P 2L6, Canada
info@cangea.ca - www.cangea.ca



Industries

The primary economic activity in Carcross is the government services including Federal, Territorial, and First Nation. Tourism is also a major industry in Carcross. The White Pass and Yukon Route Railroad brings cruise line tourists to Carcross from the Skagway port in Alaska. Carcross is home to some world-class mountain biking trails, hikes, and wind surfing on the adjacent lake.

Carmacks

Overview

Carmacks is located 2 hours north of Whitehorse along the Klondike Highway. It is located near the ancestral home of the Ts'awlnjik Dan First Nation, and the approximate boundary between the Northern and Southern Tutchone First Nations. Historically, Carmacks was an important fuelling stop for river traffic during the Klondike Gold Rush, as it is roughly half way between Whitehorse and Dawson. Carmacks is busy service area and recreational starting point for tourists on the Klondike and Campbell highways.



Carmacks, source: Google

Demographics

Table 43: Carmacks 2011 demographics¹⁰⁷

Classification	Village	Percent of population over 15	55.3%
Population in 2011	503	Total private dwellings	246
Population in 2006	425	Private dwellings occupied by usual residents	196
2006 to 2011 population change	+18.4%	Land area	36.95 km ²
Median age	34.3	Population density	13.6 / km ²

Geothermal Potential

Table 44: Temperature at depth & technical geothermal potential in Carmacks

Depth in m	Temperature	Technical	Technical	Technical
------------	-------------	-----------	-----------	-----------

	in °C	Potential with 5% recovery in MW	Potential with 14% recovery in MW	Potential with 20% recovery in MW
1,500	54	-	-	-
2,500	92	4.30	12.04	17.20
3,500	129	5.33	14.92	21.32
4,500	165	6.41	17.95	25.64

Carmacks has a well-developed temperature profile. The underground temperature reaches the input range for binary power plants well above 2000m depth, supplying Carmacks with the prospect of relatively inexpensive drilling costs. Carmacks is connected to the hydroelectric grid but due to its close proximity to mineral exploration sites, its fairly large population and excellent temperature gradient makes geothermally generated electricity an option for the region.

The evaluation of project costs for Carmacks is not 100% accurate. CanGEA has undertaken calculations for binary power plant costs in the past and the results of these calculations are used in this report. The assumptions used for these calculations are not identical to the real local circumstances.

CanGEA's archive states the cost for a 1 MW_e/13 MW_t CHP project set in a Hot Sedimentary Aquifer environment in the Canadian North with a drilling depth of 3,500m to be roughly \$28 million. A cost table can be found in Table 45. The actual cost for Carcross would be lower, as the drilling depth would stay below 2,500m.

Table 45: Cost table for an exemplary 1 MW_e/13 MW_t CHP project in northern Canada (HSA environment).

Cost Category	Cost in million \$
Exploration and Drilling	15.6
Well Pumps	1.7
ORC Unit	4.0
Facility	2.6
Construction	0.8
Materials	0.7
Engineering	0.4
Contingency	2.6

Assuming a capacity factor of 0.9, the potential to sell all produced electricity (7,884,000 kWh/a), constant achievable prices, a project lifetime of 50 years, a Weighted Average Cost of Capital (WACC) of 8%, construction cost payable up front and disregarding annual maintenance cost, the break even price for power production only is approximately \$0.27/kWh. The break-even price for Carcross would be slightly lower, since the drilling cost would be not as high as in CanGEO's archived example. If 2,500m drilling depth with an assumed cost of \$11.1 million are used, the break-even price drops to roughly \$0.23/kWh. The break-even price can be lowered / the NPV can be increased by adding a cascaded heat system that could be used for additional profit generation.

It is assumed that the temperature of the geothermal fluid leaving the binary power plant will decrease by about 17 °C from the incoming fluid, as this has been the case for other binary power plants of similar size. An outlet geothermal fluid of 75 °C allows for further cascaded use of the fluid which may be economically beneficial and is strongly suggested for Carmacks. Along with many other northern communities, district heating, horticulture and additional direct-use applications of geothermal energy may be economically viable for Carmacks.

Further demand for geothermal heat and electricity might arise from the mining operation in the surrounding area, which are discussed later in this chapter.

Geothermal Greenhouses

Horticultural applications could create value by providing locally grown fruits and vegetables for consumption by the Carmacks community. Currently fruit and vegetable prices are 27% higher than in Whitehorse. This could be mitigated by communally led greenhouses that produce fruits and vegetables locally. Carmacks already has a greenhouse, which could be upgraded and geothermally heated in order to provide produce year-round. Even industrial sized greenhouses are not out of question for Carmacks, as the surrounding mines could be potential buyers of the locally grown products. Additionally extending the greenhouse business in Carmacks could create local jobs.

Canadian Geothermal Energy Association
PO Box 1462 Station M, Calgary, Alberta, T2P 2L6, Canada
info@cangea.ca - www.cangea.ca



Geothermal power can be used to not only heat a greenhouse, but also to supply the building with electricity for artificial lighting to assist in the optimal growth of plants. A greenhouse powered by geothermal energy could make a true year-round operation possible in Carmacks and support the community with fresh produce at any time of the year.

Only 37.3% of Yukon residents reported fruit and vegetable consumption of 5 or more times per day in 2008.¹⁰⁸ Initially, a design of a greenhouse powered by geothermal energy that could produce spinach all-year round for the population of Carmacks was considered. Spinach was chosen for this design as an example of what could be grown since it is a nutrient dense vegetable, with one serving providing nutrients that include 5% of a person's daily iron and 56% of a person's daily recommended vitamin A intake. It is also a versatile vegetable that can be worked into various meals or snacks, as well as eaten raw or frozen to be consumed at a later date.

The greenhouse is designed to provide fresh vegetables all year round to the Carmacks community during 7 harvests, since spinach takes about 8 weeks until it can be harvested. To yield one servings of spinach per day, based on the Canada Food Guide, to each resident of Carmacks over a two week long period after each harvest a greenhouse would need to have approximately 1,539 sqft of growing area. This area does neither account for extra space needed to maneuver in the greenhouse nor for space for packaging and storing the produce. As it is assumed that the plants will take up 60% of the total greenhouse area, the final space needed for the operation of the greenhouse is 2,562 sqft. A harvest of this size would provide the possibility for each resident of Carmacks to consume fresh vegetables at least once per day during two weeks following each harvest. As the yield per square metre and the suggested serving size differ for each fruit and vegetable, the overall size of the greenhouse changes with its produce selection. In order to provide a serving of beets per day for every resident of Carcross the greenhouse would need a floor space of 4,004 sqft. Tomatoes can have a very high yield per square metre. Therefore it is suggested to add floor space to the greenhouse in order be able to supply fresh tomatoes on a regular basis to the residents of Carcross. A growing area of 320 sqft should suffice to produce over 20 servings of

tomatoes per resident each year. An overall size of 3,100 sqft (1,860 sqft growing area) is suggested.

Table 46: Estimated vegetable production for 1,860 sqft of growing space - Carmacks

Product	Grams per 1,860 sqft	Grams per serving	Total servings per 1,860 sqft
Spinach	276,800	32,5	8,517
Tomato	8,650,000	137	64,074
Beets	389,250	71	5,482

In cold climates, it is of importance to collect as much sunlight as possible while minimizing the negative effect that shadow has on crop growth. A length to width ratio of at least 2:1 is recommended while orienting the structure in an east-west direction. Due to the high latitude of any location within the Yukon the northern side of a greenhouse will not collect direct sunlight. The outer surfaces that are able to utilize the sun’s light and heat will be made of 3-wall polycarbonate as it can withstand high winds and a considerable snow load while offering good insulation values. The surfaces of the greenhouse that will not be in direct contact with the sunlight will be made of an aluminum frame with insulation between the inner and outer walls. This will further minimize heat loss, allowing for a more efficient heat management in the greenhouse. The whole frame of the greenhouse can be made out of aluminum, as it is the dominant material on the market. Aluminum offers multiple advantages over wood or steel, as it is longer lasting and relatively light. Additionally, the inclination on the south facing roof should be chosen in a way that maximizes the natural solar heat gain. For the Carmacks Greenhouse, a roof inclination of 45 degrees will be used to allow for this solar heat gain and easy removal of materials that may cover the roof such as snow.

With these design considerations in mind, a preliminary design for the greenhouse can be obtained, allowing for a rough cost estimate to be made. The greenhouse will be a long rectangular prism of 2:1 length to width with a triangular roof. This design coupled with a required floor space of 3,100 sqft produces a greenhouse with the following dimensions.

Table 47: Exemplary greenhouse design – Carmacks

Dimension	ft
Length	79
Width	39
Height of north/south wall	10
Height of peak	32

Table 48: Exemplary greenhouse design – surface areas - Carmacks

Dimension	ft
South Wall	787
East Wall	1,021
West Wall	1,021
North Wall	78
South Roof	2,951
North Roof	2,951
Total	9,519

The east, west and south walls as well as the south facing roof will all be made out of 3-wall polycarbonate as they will be the walls capable of using the sun’s heat and light. The north wall and north facing roof will be made out of aluminum siding/roofing with layers of insulation on the inner walls of the material to reduce heat loss. Prices are averaged prices obtained by selective market research. Real prices in Carmacks can differ.

Table 49: Exemplary greenhouse design – material cost - Carmacks

Material	Amount (ft²)	Cost (\$/ft²)	Total cost (\$)
Aluminum framing	635	2.5	1,586
Polycarbonate	5,781	1.99	11,504
Insulation	3,738	1.5	5,607
Aluminum roofing	2,951	3.99	11,773
Total			30,470

In order for the greenhouse to be operational during the whole year, it must be able to maintain an inside temperature of minimum 15 °C while the outside temperature is -34 °C, which is the estimated average low for the coldest month in Carmacks. In these conditions, a minimum heat rating of 66 kW is required. This could be provided from the

Canadian Geothermal Energy Association
PO Box 1462 Station M, Calgary, Alberta, T2P 2L6, Canada
info@cangea.ca - www.cangea.ca



power plant outlet stream. A 60 kW diesel generator, which would be sufficient for most times, on full load would require 18.2 litres of diesel per hour to provide sufficient heating in these harsh conditions. This equates to 437 litres of diesel fuel per day, costing roughly \$498 at \$1.14 per litre. As temperatures can drop below the estimated average low, a backup heating system can be installed to avoid frost damage.

It is advisable to build the greenhouse in a location close to the binary power plant to ensure the geothermal fluid flowing from the plant to the greenhouse experiences minimal heat loss during the transport. This location should also be in close proximity to the community to allow for easy access and operation. If there is existing infrastructure near a suitable building site in Carmacks, the greenhouse could be attached to a building, which will reduce the initial construction costs of the greenhouse, as well as to minimize its heat loss.

The next steps in the design of the greenhouse are to decide on lighting and piping. The lighting system and the pipes should be laid out evenly in order to maintain a uniform heat distribution within the greenhouse. Depending on the ground area of the greenhouse, two inflow pipes should be used, which transport the water in alternating directions in order to minimize the effect the heat loss along the piping system has on the uniformity of the temperature distribution within the building. The minimum temperature of the greenhouse should not drop below 0°C. In order to minimize heat loss when entering the greenhouse, a heated arctic entry should be considered. When designing the pipe and lighting layout it is important that it is closely linked to the alignment of the crops being grown. Between crop rows, tracks need to be wide enough to ensure effective harvesting and allowing maintenance on the heating and lighting system.

The northern latitude of Carmacks results in widely varying daylight periods throughout the year. The longest day of the year averages approximately 18 hours long, and the shortest day of the year is 5 hours long. This variation in daylight hours creates challenges for greenhouse operations in Carmacks, and the greenhouses must have an LED lighting system in place to accommodate for these varying amounts of sun. The lighting systems used in the Alaskan Chena Hot Springs greenhouses are designed

specifically for each crop in order to be as energy efficient as possible. Similarly, greenhouses constructed in Carmacks should be energy conscious with their lighting system, using LED lighting for their energy efficiency, and to accommodate for fluctuating daylight hours throughout the year.

Due to the low soil temperatures in a northern environment like Carmacks, the use of raised planting beds is advisable. Additionally, raised beds can make harvesting the produce easier as the beds are raised to working level.

As plants need water and fertilizer for their growth, choices on irrigation systems and fertilizer selection have to be made. For Carmacks a fertigation system would be preferable, which means that a fertilizer water solution is used. This system works on a drip irrigation basis with added root moisture sensors, which ensure an optimal moisture and nutrient level at all times.

Ventilation systems offer effective temperature adjustment with little effort. It is advisable to install an automated system, which regulates the indoor temperature through automated opening and closing of vents.

After heating the greenhouse, the could still be high enough for further cascaded applications such as drying fresh food products, heated storage or other types of public facilities, district heating and the heating of public swimming pools. These applications that could be beneficial to Carmacks, in addition to being powered in an affordable and efficient way by geothermal power will be discussed in further detail below.

Drying of Greenhouse products

The drying of food is an application that is can be particularly meaningful to northern communities, since it is a way to preserve fruits and vegetables that are not abundant in these climates for future consumption. Though it is important to note that dried fruits and vegetables cannot replace their fresh versions since there is some nutrient loss caused by dehydration, these products can be used to supplement diets and have a high caloric density with dried fruits and vegetables containing up to five time more calories than

their fresh counterparts. A food drying facility in Carmacks could use the excess heat that is available after heating the greenhouse to heat up the drying chamber. A dehumidifier and an air pump can be electrically powered and should be used in wet weather. Good primary drying conditions require a relative humidity between 20% and 50% and an air velocity of approximately 3 m/s. For perfect results a second drying process with higher temperatures and lower air velocity can be added.

Space heating

Carmacks has municipal and territorial government buildings, as well as the Yukon college campus, as well as a community centre. The dense settlement structure in part of Carmacks makes a district heating system a potentially attractive application for the community. Heat derived from the working fluid flowing out of the power plant could provide a more affordable and environmental way to heat the larger buildings of the town.

Carmacks could also be home to geothermally heated community buildings that could be used for community social events and storage, among many other potential uses. A space heated to room temperature could be used in part for animal husbandry, more specifically the raising of chickens for eggs and meat throughout the winter. This could be an important endeavour for a community like Carmacks that cannot keep animals all year round outdoors due to its cold climate. Also, eggs, which are a source of protein, are more expensive in Carmacks than in other parts of Canada.

Though aquaculture is a possible application for Carmacks, it would likely not be advantageous to the community due to the already abundant fishing practice. Also, fish, unlike eggs is a food product, which can be easily frozen to enable its consumption all year round.

Geothermal heated swimming pool

There is already a swimming pool operating in Carmacks Recreation centre. However, it only operates seasonally from May to August and Carmacks residents have expressed their desire for the pool to be opened all year round.

During the summer when the pool is open, it is heated by propane-fired boilers. This heating system also heats the changing rooms, showers and mechanical room at the pool.¹⁰⁹ Swimming pools are normally heated to between 25 and 28 °C. Installing a geothermal heat exchanger to heat the pool to this temperature would be beneficial for the community as it would provide another way for residents to exercise regularly in the winter months and is a measure to improve the quality of life in general.

In addition to the town, the mining sites that are present in the area could potentially serve as demand centres for geothermal electricity and heat. More information about the mines is portrayed later in this chapter.

Cost of Energy

Table 50: Residential energy prices in Carmacks

	Residential Service, non-government ¹¹⁰	Residential Service, government ¹¹¹
Customer charge	\$14.65	\$18.47
Energy charge for the first 1,000 kWh	12.14 ¢/kWh	16.47 ¢/kWh
Energy charge between 1,001 – 2,500 kWh	12.82 ¢/kWh	17.47 ¢/kWh
Energy charge for energy in excess of 2,500 kWh	13.99 ¢/kWh	18.85 ¢/kWh

Table 51: General service energy prices in Carmacks

	General Service, non-government ¹¹²	General Service, government - municipal ¹¹³	General Service, government – federal & territorial ¹¹⁴
Demand Charge for all kW of billing demand*	\$7.39 / kW	\$7.39 / kW	\$12.31 / kW
Energy charge for the first 2,000 kWh	10.00 ¢/kWh	10.00 ¢/kWh	13.81 ¢/kWh
Energy charge between 2,001 – 15,000 kWh	12.88 ¢/kWh	12.88 ¢/kWh	15.00 ¢/kWh
Energy charge between 15,001 – 20,000 kWh	15.68 ¢/kWh	15.68 ¢/kWh	20.00 ¢/kWh
Energy charge for energy in excess of	12.86 ¢/kWh	12.86 ¢/kWh	12.86 ¢/kWh

20,000 kWh

*where the billing demand may be estimated or measured and will be the greater of the following: A) The highest metered demand during the billing period. B) The highest metered demand during the 12 months ending with the current billing month, excluding the months April through September. C) The estimated demand. D) 5 kilowatts.

Table 52: Carmacks 2015 residential fuel prices¹¹⁵

Month	Furnace Oil (¢/L)	Arctic Stove Oil (¢/L)	Propane (\$/500 gallon tank)
December	101.6	104.8	71.3
November	103.7	106.9	74.3
October	103.7	106.9	81.0
September	103.7	106.9	81.0
August	109.0	112.1	79.3
July	109.0	112.1	79.3
June	109.0	112.1	82.5
May	109.0	112.1	85.6
April	109.0	112.1	84.9
March	109.0	112.1	84.5
February	109.0	112.1	84.5
January	113.7	116.9	87.7

Infrastructure

Table 53: Carmacks infrastructure profile

List of Relevant Infrastructure	
Transportation Infrastructure	Tourism infrastructure
Highway access via Klondike Highway	Hotels
Airport/helicopter base within village limits	Restaurants
	RV park & campground
Communication Infrastructure	Emergency Services
Cell reception: Latitude Wireless	Health Centre (2 nurses on staff)
High speed internet: NorthwesTel	Volunteer Ambulance on call 24 hours
Landline phone service: NorthwesTel	Medevac available 24 hours for emergencies
	Volunteer Fire on call 24 hours
	RCMP detachment
Business Infrastructure	Housing Infrastructure
Municipal government office	246 Private dwellings
Territorial offices	195 Normally occupied dwellings
Lands and Forestry office	110 Single detached houses
TD Bank	0 Apartments (5+ storeys)
Grocery store	0 Apartments (<5 storeys)
Greenhouse	75 Movable dwellings

Shopping and service stores	10 Semi-detached houses 5 Row houses 0 Duplexes
Educational Infrastructure	Recreation Infrastructure
Grade school up to grade 12 Yukon College Carmacks Campus	Community Centre Gymnasium Summer swimming pool Curling facilities

Economics

Table 54: Carmacks 2015 Spatial Price Index (Whitehorse = 100)¹¹⁶

Meat	115.2	Household Operations	108.1
Dairy/eggs	115.0	Health and Personal Care	111.7
Fruit/vegetables	126.9	Gasoline	108.1
Bread/cereal	121.2	Cigarettes	106.9
Other Foods	116.8	Total Survey Items	112.6

Industries

The economic base of Carmacks includes government services in the federal, territorial, Indigenous Peoples and municipal governments. Private industries primarily include mining, construction, tourism and the service industry.

Carmacks Copper Mine

The Carmacks copper mine is a proposed mine by the Copper North Mining Corp. A feasibility study was completed in November 2012, followed by a preliminary economic assessment in May 2014. Copper North Mining Corp announced on January 21, 2015 that it was going forward with an agitated tank leach of both copper and gold & silver. Copper North Mining Corp commenced drilling in July 2015, focusing on both new detailed geophysical targets and definition drilling of several of the mineral zones to expand mineral resources.

Table 55: Carmacks copper mine based on preliminary economic assessment – June 2014¹¹⁷

Ownership	100%
Resource	11.6 million tonnes (measured and indicated)
Primary Metals	Copper, gold and silver
Process	Heap leach, solvent extraction/electrowinning of copper and cyanide leach of gold and silver
End Products	Copper cathode, gold-silver dore
Mine Type	Open pit
Mine Life	7+ years
Employees	180 (peak production), 250 (peak construction)
Location	38 km NW of Carmacks, YT – 400 km N of year round port at Skagway, AK
Infrastructure	Good road access, upgrade of a 13km access road
Power	11km from Yukon power grid
Status	Engineering / Permitting

Little Salmon Carmacks First Nation’s Greenhouse and Farm Operations

Dawn Charlie of the Little Salmon Carmacks First Nations (LSCFN) started this community garden project in 2000. Since 2000 it has grown from a root cellar into two greenhouses and a garden plot. Seasonal produce includes potatoes, tomatoes, beans, corn, melons, peppers, peas, lettuce, and cucumbers. The



Carmacks greenhouse, source: Yukon Wellness

fresh foods are distributed in part to community members in the Carmacks diabetes program, part to the First Nation for local events, and part is sold farm-gate style to tourists and locals. The greenhouse has also donated extra produce to the local school lunch program. The vision for the future of the greenhouse includes seeing enough vegetables produced so that some can be canned or frozen for winter sales. Year round sales would help the greenhouse profits, and provide a permanent source of employment and high-quality local food for the community. Dawn has been quoted

saying “My dream is that every community in the North would have a greenhouse option. It’s so much healthier, so much more environmentally friendly. People from other Northern communities come here all the time to look and learn. It makes such a difference to have fresh, local food – food that’s clean, healthy, and contributing to your community.” The Carmacks greenhouse is a pioneer and established leader in Northern greenhousing, with clear motivation for year round food sales. This greenhouse may be a suitable operation for a direct use of heat geothermal pilot project, where geothermal heating could allow for year round production of vegetables for Carmacks area, and potentially other Northern communities.

Casino Mine

The Casino mine is owned by the Casino Mining Corporation, a subsidiary of Western Copper and Gold, and represents a large-scale gold and copper exploitation project. According to the Casino Mining Corporation, the mine would have the potential to process 120,000 tonnes of ore daily and produce more than 400,000 ounces of gold and more than 200 million pounds of copper annually. Peak construction employment would total roughly 1,000 workers. The lifetime of the mine is calculated to be at least 22 years and it would operate as a conventional open-pit project. The project is located within the territory of the Selkirk First Nation, while the road access would lie within the territories of the Selkirk and Little Salmon/Carmacks First Nations. The Tr’ondëk Hwëch’in territory neighbours the mining site to the north. Road access to the mine is proposed to be the prolongation of the currently existing Freegold Road, which is located 70 km northwest of Carmacks. At the moment the power production for the mine is planned to be generated by the combustion of LNG in a 144 MW power plant. The LNG supply would be by truckload. Currently the project is in the environmental assessment phase.

Table 56: Casino mine based on project proposal – Jan 2014¹¹⁸

Ownership	100% Western Copper & Gold Corporation
Process capability	120,000 tonnes of ore daily
Primary Metals	Copper, gold, molybdenum and silver
Process	Heap leach + flotation
Mine Type	Open pit
Mine Life	22 years
Employees	600 (peak production), 1000 (peak construction)

Location	200 km from Carmacks, YT
Infrastructure	132km gravel road (to be built); staff fly-in fly-out
Power	LNG plant (to be built)
Status	Environmental Assessment

Coffee Mine

The Coffee Mine project is located 160 km northwest of Carmacks and is owned by the Kaminak Gold Corporation. The project focuses on the open-pit exploitation of gold reserves and according to Kaminak the mine could produce 1,859,000 ounces of gold during an estimated eleven-year lifecycle. The average production per annum is forecasted to be roughly 167,000 ounces of gold. Since its discovery in 2010, Kaminak has accomplished 16 gold discoveries, while only 20% of the 150,000-acre property has been explored. Access to the site is not possible by road, even though once on site a 23km road network has been established. The Tr’ondëk Hwëch’in First Nation has recently supported an access road to the Coffee project. To power the mine and its equipment, Kaminak has proposed to use Diesel generators.

Table 57: Coffee mine based on preliminary economic assessment – June 2014¹¹⁹

Ownership	100% Kaminak Gold Corporation
Resource	53.4 million tonnes (measured and indicated heap leach feed)
Primary Metals	Gold
Process	Heap leach
Mine Type	Open pit
Mine Life	11 years
Employees	180 (peak production), 250 (peak construction)
Location	160 km NW of Carmacks, YT (air)
Infrastructure	250 km access road planned, accessible by water & air
Power	Diesel
Status	Feasibility Study

Klaza Mine

The Klaza property encompasses 8,620 hectares and is located 50 km west of Carmacks. The property is owned by Rockhaven Resources Ltd and is still in the early exploration phase. The project targets gold and silver deposits in an area that lies within the traditional territory of the Little Salmon Carmacks First Nation. The site is accessible by a two-wheel drive road off of the Klondike Highway.

Canadian Geothermal Energy Association
 PO Box 1462 Station M, Calgary, Alberta, T2P 2L6, Canada
 info@cangea.ca - www.cangea.ca



The project has been assessed by Skivik Holding Co. Ltd., Giroux Consultants Ltd. and Blue Coast Metallurgy Ltd., which share the opinion that the Klaza site features considerable amounts of mineralization and propose that exploratory work should be pursued further. In August 2015 the Little Salmon Carmacks First Nation expressed their support of the Klaza project by signing an exploration benefits agreement.

Table 58: Klaza mine based on technical report – June 2015¹²⁰

Ownership	100% Rockhaven Ltd.
Resource	11.6 million tonnes (measured and indicated)
Primary Metals	Gold and silver
Process	-
Mine Type	Open pit
Mine Life	7+ years
Employees	180 (peak production), 250 (peak construction)
Location	50 km W of Carmacks, YT
Infrastructure	Good road access
Power	-
Status	Exploration

Dawson City

Overview

Dawson City is Yukon’s second largest city. It is located 5 hours north of Whitehorse along the Klondike Highway. It is also a 3-hour drive from Tok, Alaska on the Top of the World Highway, but this route is closed during the winter months. Dawson is home to the Tr’ondëk Hwëch’in (People of the River), making up approximately one third of the residents. During the Klondike Gold Rush, Dawson was a bustling city of 25,000 nicknamed the “Paris of the North.” These days many people in Dawson work in the tourism, mining, and public services.



Dawson City, source: Google

Demographics

Table 59: Dawson 2011 demographics¹²¹

Classification	Town	Percent of population over 15	85.3%
Population in 2011	1,319	Total private dwellings	727
Population in 2006	1,327	Private dwellings occupied by usual residents	629
2006 to 2011 population change	-0.6%	Land area	32.45 km ²
Median age	39.3	Population density	40.7 / km ²

Geothermal Potential

Table 60: Temperature at depth & technical geothermal potential in Dawson

Depth in m	Temperature in °C	Technical Potential with 5%	Technical Potential with 14%	Technical Potential with 20%
------------	-------------------	-----------------------------	------------------------------	------------------------------

		recovery in MW	recovery in MW	recovery in MW
1,500	30	-	-	-
2,500	53	-	-	-
3,500	75	-	-	-
4,500	96	4.17	11.68	16.68

Dawson City’s temperature profile suggests rather low temperature underground with binary power generation cut-off temperatures being reached at around 3,500m depth. The necessary drilling costs and the fact that Dawson City is part of the hydroelectric grid, make economic geothermal power generation rather unlikely.

Dawson City’s population and the fact that it attracts many summer tourists may lead to tourist targeted low temperature direct-use applications being viable. Tourist attractions like geothermally heated swimming pools can be a huge economical success. In Dawson’s case the limiting factor to any development are the drilling costs.

Cost of Energy

Table 61: Residential energy prices in Dawson

	Residential Service, non-government ¹²²	Residential Service, government ¹²³
Customer charge	\$14.65	\$18.47
Energy charge for the first 1,000 kWh	12.14 ¢/kWh	16.47 ¢/kWh
Energy charge between 1,001 – 2,500 kWh	12.82 ¢/kWh	17.47 ¢/kWh
Energy charge for energy in excess of 2,500 kWh	13.99 ¢/kWh	18.85 ¢/kWh

Table 62: General service energy prices in Dawson

	General Service, non-government ¹²⁴	General Service, government - municipal ¹²⁵	General Service, government – federal & territorial ¹²⁶
Demand Charge for all kW of billing demand*	\$7.39 / kW	\$7.39 / kW	\$12.31 / kW
Energy charge for the first 2,000 kWh	10.00 ¢/kWh	10.00 ¢/kWh	13.81 ¢/kWh
Energy charge between	12.88 ¢/kWh	12.88 ¢/kWh	15.00 ¢/kWh

2,001 – 15,000 kWh			
Energy charge between 15,001 – 20,000 kWh	15.68 ¢/kWh	15.68 ¢/kWh	20.00 ¢/kWh
Energy charge for energy in excess of 20,000 kWh	12.86 ¢/kWh	12.86 ¢/kWh	12.86 ¢/kWh

*where the billing demand may be estimated or measured and will be the greater of the following: A) The highest metered demand during the billing period. B) The highest metered demand during the 12 months ending with the current billing month, excluding the months April through September. C) The estimated demand. D) 5 kilowatts.

Table 63: Dawson 2015 residential fuel prices¹²⁷

Month	Furnace Oil (¢/L)	Arctic Stove Oil (¢/L)	Propane (\$/500 gallon tank)
December	107.1	108.3	71.3
November	109.2	111.8	74.3
October	109.2	112.8	82.4
September	109.2	110.8	81.0
August	114.5	113.5	79.3
July	114.5	114.3	79.3
June	114.5	115.2	82.5
May	114.5	114.5	85.6
April	114.5	117.3	84.9
March	114.5	117.9	84.5
February	114.5	114.4	84.5
January	119.2	123.1	87.7

Infrastructure

Table 64: Dawson infrastructure profile

List of Relevant Infrastructure	
Transportation Infrastructure	Tourism infrastructure
Highway access via Klondike Highway	Hotels
Top of the World Highway access (seasonal)	Restaurants
Dawson City Airport (1,524 m gravel runway)	RV park & campground
Communication Infrastructure	Emergency Services
Cell reception: Latitude Wireless	Hospital (24/7 acute care services)
High speed internet: NorthwTel	Health Centre (5 nurses)
Landline phone service: NorthwTel	Medical Clinic (2 physicians + staff)
	Ambulance (staff/volunteer)
	Fire (staff/volunteer)
	RCMP detachment
Business Infrastructure	Housing Infrastructure
Klondike Development Organization	727 Private dwellings
Dawson City Chamber of Commerce	629 Normally occupied dwellings

Klondike Placer Miners Association Supermarket CIBC Bank Shopping and service stores	470 Single detached houses 0 Apartments (5+ storeys) 80 Apartments (<5 storeys) 25 Movable dwellings 50 Semi-detached houses 5 Row houses 5 Duplexes
Educational Infrastructure	Recreation Infrastructure
Grade school up to grade 12 Yukon College Dawson Campus Dawson City Community Library Yukon School of Visual Arts Klondike School of Art and Culture	Fitness centre Seasonal swimming pool Ice arena Curling rink Danoja Zho Cultural Centre

Economics

Table 65: Dawson 2015 Spatial Price Index (Whitehorse = 100)¹²⁸

Meat	108.6	Household Operations	127.9
Dairy/eggs	116.7	Health and Personal Care	129.4
Fruit/vegetables	121.2	Gasoline	113.7
Bread/cereal	117.0	Cigarettes	108.2
Other Foods	121.4	Total Survey Items	116.2

Industries

The economic base of Dawson City is tourism. Dawson is a popular destination because of its colourful past and rich history in the Klondike Gold Rush. There are several institutions and events that promote arts and culture in Dawson including: the Dawson City Arts Society, the Klondike Institute of Arts and Culture, the Dawson City Music Festival, the Klondike Visitors Association, and the Yukon School of Visual Arts. The mining industry that initially drew people to Dawson is still alive. There are close to 100 placer miner families still operating in the Klondike region.

Brewery Creek Mine

The Brewery Creek mine is 55 km east of Dawson City and was operational from 1997 to 2001. It was the largest lode gold mine ever built in the Yukon, consisting of 801

claims with leases covering 16,160 ha. It was a year round heap leach operation with a seasonal open-pit mining capacity of 11,000 tonnes of ore per day. Golden Predator Canada Corp took ownership of the mine in 2012 and is now responsible for reclamation and closure activities¹²⁹. Golden Predator has conducted exploration including geophysical surveys, soil sampling, and an extensive drilling campaign to define the limits of known mineralized zones and examine previously untested parts of the property. Mineral resource estimates have previously been reported by Golden Predator for a total of 15 individual deposits. A preliminary economic assessment of Brewery Creek in November 2014 estimate a recoverable 372,000 ounces of gold from 8 open pits and old heap leach material with a 9 year mine life with seasonal mining and crushing scheduled for 230 days per year at 7,500 tonnes per day, along with year round leaching. Power for the Brewery Creek Property is to be supplied by on-site generation using diesel fuel along with a substation to house the main 4.16 kV switchgear for distributing power on site, and a building to house the generators. Power supply is also available from through the Yukon Energy Corporation via a 27 km long, 69 kV utility transmission line from Dempster Corner, though this was not considered for the preliminary economic assessment. An overall capital cost of \$US 89.4 million has been estimated for the project, of which \$US 3.3 million is allocated to site infrastructure.



Brewery Creek Mine Infrastructure, source: Golden Predator Mining Corp.¹³⁰

Canadian Geothermal Energy Association
 PO Box 1462 Station M, Calgary, Alberta, T2P 2L6, Canada
 info@cangea.ca - www.cangea.ca



Table 66: Brewery Creek mine based on preliminary economic assessment – January 2015¹³¹

Ownership	100%
Resource	23.4 million tonnes (indicated + inferred oxide)
Primary Metals	Gold
Process	Heap Leach
Mine Type	Open pit
Mine Life	9 years
Employees	180 (peak production), 250 (peak construction)
Location	55 km east of Dawson
Infrastructure	Good road access
Power	27km from Yukon power grid (to be constructed) or diesel
Status	Economic Assessment

Destruction Bay

Overview

Destruction Bay is 1 hour northwest of Haines Junction, 3 hours from Whitehorse along the Alaska Highway, and is 17 km south east of Burwash Landing, of which it shares many services. Destruction Bay is home to the Kluane First Nations, the majority of the First Nation people in this area identify as Southern Tutchone. There is interest in renewable energy in the nearby community of Burwash Landing, which shares the same diesel generating facility.



Destruction Bay, source: Google

Demographics

Table 67: Destruction Bay Landing 2011 demographics¹³²

Classification	Settlement	Percent of population over 15	No Data
Population in 2011	35	Total private dwellings	32
Population in 2006	55	Private dwellings occupied by usual residents	17
2006 to 2011 population change	-36.4%	Land area	13.57 km ²
Median age	No Data	Population density	2.6 / km ²

Geothermal Potential

Table 68: Temperature at depth & technical geothermal potential in Destruction Bay

Depth in m	Temperature in °C	Technical Potential with 5% recovery in MW	Technical Potential with 14% recovery in MW	Technical Potential with 20% recovery in MW
1,500	29	-	-	-

2,500	49	-	-	-
3,500	69	-	-	-
4,500	88	4.35	12.18	17.40

For detailed information about the geothermal potential of the area, please consult the Burwash Landing chapter of this report.

Cost of Energy

Destruction Bay is an off-grid community; electricity is generated from a 0.9 MW diesel facility that powers both Destruction Bay and the nearby community of Burwash Landing.

Table 69: Residential energy prices in Destruction Bay

	Residential Service, non-government ¹³³	Residential Service, government ¹³⁴
Customer charge	\$14.65	\$18.47
Energy charge for the first 1,000 kWh	12.14 ¢/kWh	16.47 ¢/kWh
Energy charge between 1,001 – 2,500 kWh	12.82 ¢/kWh	17.47 ¢/kWh
Energy charge for energy in excess of 2,500 kWh	13.99 ¢/kWh	18.85 ¢/kWh

Table 70: General service energy prices in Destruction Bay

	General Service, non-government ¹³⁵	General Service, government - municipal ¹³⁶	General Service, government – federal & territorial ¹³⁷
Demand Charge for all kW of billing demand*	\$7.39 / kW	\$7.39 / kW	\$12.31 / kW
Energy charge for the first 2,000 kWh	10.00 ¢/kWh	10.00 ¢/kWh	13.81 ¢/kWh
Energy charge between 2,001 – 15,000 kWh	12.88 ¢/kWh	12.88 ¢/kWh	15.00 ¢/kWh
Energy charge between 15,001 – 20,000 kWh	15.68 ¢/kWh	15.68 ¢/kWh	20.00 ¢/kWh
Energy charge for energy in excess of 20,000 kWh	15.22 ¢/kWh	15.22 ¢/kWh	15.22 ¢/kWh

*where the billing demand may be estimated or measured and will be the greater of the following: A) The highest metered demand during the billing period. B) The highest

metered demand during the 12 months ending with the current billing month, excluding the months April through September. C) The estimated demand. D) 5 kilowatts.

Table 71: Destruction Bay 2015 residential fuel prices¹³⁸

Month	Furnace Oil (¢/L)	Arctic Stove Oil (¢/L)	Propane (\$/500 gallon tank)
December	100.9	104.1	No Data
November	103	106.2	No Data
October	103	106.2	No Data
September	103	106.2	No Data
August	108.3	111.4	No Data
July	108.3	111.4	No Data
June	108.3	111.4	No Data
May	108.3	111.4	No Data
April	108.3	111.4	No Data
March	108.3	111.4	No Data
February	108.3	111.4	No Data
January	No Data	No Data	No Data

Infrastructure

Table 72: Destruction Bay infrastructure profile

List of Relevant Infrastructure	
Transportation Infrastructure	Tourism infrastructure
Highway access via Alaska Highway Gravel airstrip maintained year round	Hotel Restaurant RV park
Communication Infrastructure	Emergency Services
Cell reception: Latitude Wireless High speed internet: NorthwesTel Landline phone service: NorthwesTel	Health Centre in Destruction Bay Volunteer Ambulance in Destruction Bay Medevac available 24 hours for emergencies RCMP detachment in Haines Junction
Business Infrastructure	Housing Infrastructure
Gas Station General Store Laundromat	32 Private dwellings 17 Normally occupied dwellings - Single detached houses - Apartments (5+ storeys) - Apartments (<5 storeys) - Movable dwellings - Semi-detached houses - Row houses - Duplexes

Educational Infrastructure	Recreation Infrastructure
Grade school up to grade 8 Kluane Lake Research Station	

Economics

Table 73: Destruction Bay 2015 Spatial Price Index (Whitehorse = 100)

Meat	No Data	Household Operations	No Data
Dairy/eggs	No Data	Health and Personal Care	No Data
Fruit/vegetables	No Data	Gasoline	No Data
Bread/cereal	No Data	Cigarettes	No Data
Other Foods	No Data	Total Survey Items	No Data

Industries

The Kluane Community Development Corporation (KCDC), based in Burwash Landing 17 km away supports both settlements with community development projects, research and business case preparation, management of community based businesses, provides entrepreneurial support, and fundraising and proposal writing for all Yukon Economic Development and Corporate initiatives. Tourism is also a main economic driver in the community between the months of May to September, and the Arctic Institute of North America’s Kluane Lake Research Station can host up to 40 researchers during the summer. Destruction Bay and Burwash Landing are not connected to the main Yukon electric grid, but are powered together by a single diesel facility. More information on power generation and renewable energy development in this area can be found in the *Industries* section of the Burwash Landing community profile.

Faro

Overview

Faro is located 4 hours north of Whitehorse and 2 hours east of Carmacks along the Robert Campbell Highway. Faro is situated within the traditional territory of the Ross River Dena Council. Although the First Nation people have never settled in Faro permanently, they have worked cooperatively with the Town of Faro on projects including the remediation of the Faro mine site and development & management of the Dena Cho Trail. Faro was once home to the world's largest lead, silver, and zinc mine that operated from 1970 to 1998.

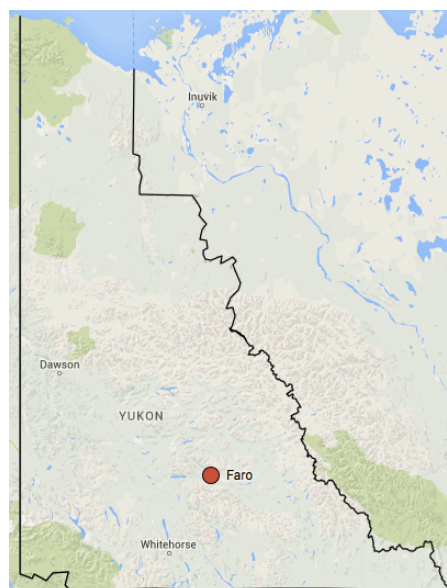

Faro, source: Google

Demographics

Table 74: Faro 2011 demographics¹³⁹

Classification	Town	Percent of population over 15	85.8%
Population in 2011	344	Total private dwellings	444
Population in 2006	341	Private dwellings occupied by usual residents	167
2006 to 2011 population change	+0.9%	Land area	203.57 km ²
Median age	50.2	Population density	1.7 / km ²

Geothermal Potential

Table 75: Temperature at depth & technical geothermal potential in Faro

Depth in m	Temperature	Technical	Technical	Technical
------------	-------------	-----------	-----------	-----------

	in °C	Potential with 5% recovery in MW	Potential with 14% recovery in MW	Potential with 20% recovery in MW
1,500	39	-	-	-
2,500	65	-	-	-
3,500	91	4.31	12.07	17.24
4,500	116	5.02	14.06	20.08

Faro is part of the main hydroelectric grid and features a temperature profile that suggests that the binary power plant cut off temperature is reached between 2,500 and 3,000 m depth.

Faro has a high overall consumption of electricity where the commercial sector alone requires a significant amount of electricity to operate. Some of the commercial buildings that require electricity are Faro Real Estate, M. Hampton’s Shop and Discovery Store & Faro Hardware. Moreover, some of the house pumps in Faro require tremendous amount of electricity per year such as an electric pump that is used for water treatment consuming around 250,000 kWh electricity per year. While most of these electricity needs are met by the standing grid connection and diesel sources, a diesel generator is required to meet the peak electricity demand.

There is an 8.5 MW diesel facility installed to power Faro when the hydroelectric grid is not able to meet the electricity demand. This diesel back-up facility is owned by the Yukon Energy Corporation.¹⁴⁰ With a very low recovery factor of only 5%, 4.31 MW of electricity could be produced from the geothermal fluid at 3,500m.

CanGEA’s archive states the cost for a 1 MW_e/13 MW_t CHP project set in a Wet Fractured Rock environment in the Canadian North to be roughly \$31 million. A cost table can be found in Table 76. The actual cost for Faro would likely be slightly higher, as the drilling depth is estimated to be deeper than in the calculatory example (2,100m).

Table 76: Cost table for an exemplary 1 MW_e/13 MW_t CHP project in northern Canada (Wet Fractured Rock environment).

Cost Category	Cost in million \$
---------------	--------------------

Exploration and Drilling	18.0
Well Pumps	1.7
ORC Unit	4.0
Facility	2.6
Construction	0.8
Materials	0.7
Engineering	0.5
Contingency	2.8

Assuming a capacity factor of 0.9, the potential to sell all produced electricity (7,884,000 kWh/a), constant achievable prices, a project lifetime of 50 years, a Weighted Average Cost of Capital (WACC) of 8%, construction cost payable up front and disregarding annual maintenance cost, the break even price for power production only is approximately \$0.30/kWh. The break-even price can be lowered / the NPV can be increased by adding a cascaded heat system that could be used for additional profit generation.

Due to limited heavy-users of electricity and the standing grid connection it is questionable if geothermal power could be used economically for electricity generation in Faro. It is contemplated that community institutions could be heated by geothermal energy. Of special interest in this case is the gym, the college, the school and the pool, which is currently only open during the summer months. Geothermal heat could potentially be used to lower the heating costs of the pool in the summer time and extend the bathing period.

It is assumed that the temperature of the geothermal fluid leaving the binary power plant will decrease by about 17 °C from the incoming fluid, as this has been the case for other binary power plants of similar size. An outlet geothermal fluid of 58 °C allows for further cascaded use of the fluid which may be economically beneficial and is strongly suggested for Faro.

Geothermal Greenhouses

Horticultural applications could create value by providing locally grown fruits and vegetables for consumption by the Faro community. Geothermal power can be used to

not only heat a greenhouse, but also to supply the building with electricity for artificial lighting to assist in the optimal growth of plants. A greenhouse powered by geothermal energy could make a true year-round operation possible in Faro and support the community with fresh produce at any time of the year.

Only 37.3% of Yukon residents reported fruit and vegetable consumption of 5 or more times per day in 2008.¹⁴¹ In Faro, fruit and vegetables are currently 27% more expensive than in Whitehorse while other food is 32% more expensive. Initially, a design of a greenhouse powered by geothermal energy that could produce spinach all-year round for the population of Faro was considered. Spinach was chosen for this design as an example of what could be grown since it is a nutrient dense vegetable, with one serving providing nutrients that include 5% of a person's daily iron and 56% of a person's daily recommended vitamin A intake. It is also a versatile vegetable that can be worked into various meals or snacks, as well as eaten raw or frozen to be consumed at a later date.

The greenhouse is designed to provide fresh vegetables all year round to the Faro community during 6 harvests, since spinach takes about 8 weeks until it can be harvested. To yield on servings of spinach per day, based on the Canada Food Guide, to each resident of Faro over a three week long period after each harvest a greenhouse would need to have approximately 1,582 sqft of growing area. This area does neither account for extra space needed to maneuver in the greenhouse nor for space for packaging and storing the produce. As it is assumed that the plants will take up 60% of the total greenhouse area, the final space needed for the operation of the greenhouse is 2,637 sqft. A harvest of this size would provide the possibility for each resident of Carmacks to consume fresh vegetables at least once per day during three weeks following each harvest. As the yield per square metre and the suggested serving size differ for each fruit and vegetable, the overall size of the greenhouse changes with its produce selection. In order to provide a serving of beets per day for every resident of Carcross the greenhouse would need a floor space of 4,101 sqft. Tomatoes can have a very high yield per square metre. Therefore it is suggested to add floor space to the greenhouse in order be able to supply fresh tomatoes on a regular basis to the residents of Carcross. A growing area of 220 sqft should suffice to produce over 20 servings of

tomatoes per resident each year. An overall size of 3,000 sqft (1,800 sqft growing area) is suggested.

Table 77: Estimated vegetable production for 6,000 sqft of growing space - Faro

Product	Grams per 6,000 sqft	Grams per serving	Total servings per 6,000 sqft
Spinach	267,200	32,5	8,222
Tomato	8,350,000	137	61,852
Beets	375,750	71	5,292

In cold climates, it is of importance to collect as much sunlight as possible while minimizing the negative effect that shadow has on crop growth. A length to width ratio of at least 2:1 is recommended while orienting the structure in an east-west direction. Due to the high latitude of any location within the Yukon the northern side of a greenhouse will not collect direct sunlight. The outer surfaces that are able to utilize the sun’s light and heat will be made of 3-wall polycarbonate as it can withstand high winds and a considerable snow load while offering good insulation values. The surfaces of the greenhouse that will not be in direct contact with the sunlight will be made of an aluminum frame with insulation between the inner and outer walls. This will further minimize heat loss, allowing for a more efficient heat management in the greenhouse. The whole frame of the greenhouse can be made out of aluminum, as it is the dominant material on the market. Aluminum offers multiple advantages over wood or steel, as it is longer lasting and relatively light. Additionally, the inclination on the south facing roof should be chosen in a way that maximizes the natural solar heat gain. For the Faro Greenhouse, a roof inclination of 45 degrees will be used to allow for this solar heat gain and easy removal of materials that may cover the roof such as snow.

With these design considerations in mind, a preliminary design for the greenhouse can be obtained, allowing for a rough cost estimate to be made. The greenhouse will be a long rectangular prism of 2:1 length to width with a triangular roof. This design coupled with a required floor space of 3,000 sqft produces a greenhouse with the following dimensions.

Table 78: Exemplary greenhouse design – Faro

Dimension	ft
Length	77
Width	39
Height of north/south wall	10
Height of peak	41

Table 79: Exemplary greenhouse design – surface areas - Faro

Dimension	ft
South Wall	775
East Wall	995
West Wall	995
North Wall	775
South Roof	2,855
North Roof	2,855
Total	9,249

The east, west and south walls as well as the south facing roof will all be made out of 3-wall polycarbonate as they will be the walls capable of using the sun’s heat and light. The north wall and north facing roof will be made out of aluminum siding/roofing with layers of insulation on the inner walls of the material to reduce heat loss. Prices are averaged prices obtained by selective market research. Real prices in Faro can differ.

Table 80: Exemplary greenhouse design – material cost - Faro

Material	Amount (ft ²)	Cost (\$/ft ²)	Total cost (\$)
Aluminum framing	616	2.5	1,539
Polycarbonate	5,619	1.99	11,183
Insulation	3,630	1.5	5,445
Aluminum roofing	2,855	3.99	11,393
Total			29,560

In order for the greenhouse to be operational during the whole year, it must be able to maintain an inside temperature of minimum 15 °C while the outside temperature is -25 °C, which is the estimated average low in the coldest month for Faro. In these conditions, a minimum heat rating of 53kW is required. This will be provided from the power plant outlet stream. A 75kW diesel generator on ¾ load would require 17.4 litres

Canadian Geothermal Energy Association
PO Box 1462 Station M, Calgary, Alberta, T2P 2L6, Canada
info@cangea.ca - www.cangea.ca



of diesel per hour to provide sufficient heating in these harsh conditions. This equates to 418 litres of diesel fuel per day, costing roughly \$477 at \$1.14 per litre. As temperatures can drop below the estimated average low, a backup heating system can be installed to avoid frost damage.

It is advisable to build the greenhouse in a location close to the binary power plant to ensure the geothermal fluid flowing from the plant to the greenhouse experiences minimal heat loss during the transport. This location should also be in close proximity to the community to allow for easy access and operation. If there is existing infrastructure near a suitable building site in Faro, the greenhouse could be attached to a building, which will reduce the initial construction costs of the greenhouse, as well as to minimize its heat loss.

The next steps in the design of the greenhouse are to decide on lighting and piping. The lighting system and the pipes should be laid out evenly in order to maintain a uniform heat distribution within the greenhouse. Depending on the ground area of the greenhouse, two inflow pipes should be used, which transport the water in alternating directions in order to minimize the effect the heat loss along the piping system has on the uniformity of the temperature distribution within the building. The minimum temperature of the greenhouse should not drop below 0°C. In order to minimize heat loss when entering the greenhouse, a heated arctic entry should be considered. When designing the pipe and lighting layout it is important that it is closely linked to the alignment of the crops being grown. Between crop rows, tracks need to be wide enough to ensure effective harvesting and allowing maintenance on the heating and lighting system.

The northern latitude of Faro results in widely varying daylight periods throughout the year. The longest day of the year averages approximately 18 hours long, and the shortest day of the year is roughly 5 hours long. This variation in daylight hours creates challenges for greenhouse operations in Faro, and the greenhouses must have an LED lighting system in place to accommodate for these varying amounts of sun. The lighting systems used in the Alaskan Chena Hot Springs greenhouses are designed specifically for each crop in order to be as energy efficient as possible. Similarly, greenhouses

constructed in Faro should be energy conscious with their lighting system, using LED lighting for their energy efficiency, and to accommodate for fluctuating daylight hours throughout the year.

Due to the low soil temperatures in a northern environment like Faro, the use of raised planting beds is advisable. Additionally, raised beds can make harvesting the produce easier as the beds are raised to working level.

As plants need water and fertilizer for their growth, choices on irrigation systems and fertilizer selection have to be made. For Faro a fertigation system would be preferable, which means that a fertilizer water solution is used. This system works on a drip irrigation basis with added root moisture sensors, which ensure an optimal moisture and nutrient level at all times.

Ventilation systems offer effective temperature adjustment with little effort. It is advisable to install an automated system, which regulates the indoor temperature through automated opening and closing of vents.

This temperature remains after the heating process might be used for further cascaded applications such as drying fresh food products, heated storage or other types of public facilities, district heating and the heating of public swimming pools. These applications that could be beneficial to Faro, in addition to being powered in an affordable and efficient way by geothermal power will be discussed in further detail below.

Space heating

The dense settlement structure in part of Faro makes a district heating system a potentially attractive application for the community.

Faro could also be home to geothermally heated community buildings like the library, school, or the community centre. In addition heated communal buildings could be used for community social events and storage, among many other potential uses. A space heated to room temperature could be used in part for animal husbandry, more

specifically the raising of chickens for eggs and meat throughout the winter. This could be an important endeavour for a community like Faro that cannot keep animals all year round outdoors due to its cold climate.

Of particular interest are community institutions such as the school, gym, Yukon College Faro Campus. Since the recreation centre, swimming pool and arena are located very close to each other, effective distribution of heat derived from geothermal energy is possible. The recreation centre consists of the gymnasium, youth lounge, weight room, kitchen etc. all of which can be heated through a geothermal source. The arena, which is known as the Father Pierre Rigaud Arena is to the east of the recreation centre and is currently heated by a pair of oil fired forced air furnaces. As of right now, most of the buildings in Faro are heated through oil furnaces, which account for 38% of GHG emissions.¹⁴² Moreover, Yukon College has a high heat load. As Faro has prioritized the reduction of GHG in their Community Energy Plan, the introduction of geothermal heating will serve as a great addition allowing them to stay in line with their environmental goals.

Aquaculture

Different species of fish could be raised for human consumption all year round in Faro through the use of aquaculture powered and heated by geothermal energy.

Some examples of fish that are native to this region are Arctic grayling, northern pike and lake trout. For this example, an aquaculture system for the farming of rainbow trout, a commonly cultured fish that cannot already be found in Faro is suggested. Rainbow trout is a good source of protein with an average marketable size fish, between 0.5 to 1.0 kg and a good source of Omega-3 essential acids. Trout will exhibit optimum growth at 17°C, though they can survive between temperatures of 0°C to 27°C. This species of trout will take about 6 to 8 months to reach their optimal market size.

For fish of 500g in size, the tank should be able to maintain a flow through of 5 l/min/m³ and can produce about 50 fish per m³. For a community like Faro a reasonably large tank could be built and the fish produced could be frozen for later consumption or to be

sold to nearby communities. To complete all steps of fish farming in Faro, hatching and rearing tanks will also need to be constructed. The location of Faro close to a freshwater source is ideal since this water could be used to fill the tanks in which to grow the trout.

General assumptions can be made about the piping that will be required for the heat exchanger and their location in relation to the tank. For example, steel or FRP (Fibreglass Reinforced Plastic) piping could be used to carry the hot fluid to and from the heat exchanger and PVC piping could be used to circulate the warm fluid through the tank. A method to reduce heat loss due to the cold northern temperatures and evaporation all year round from the tanks would be to cover them with a roof structure similar to that of a greenhouse and heat the space surrounding the tank.

One way to simplify the aquaculture system is to grow vegetation on the surface of the water that will enable some feeding of the trout, as well as to filter the water in the tanks. For example, numerous floating and rooted water plants could be grown on the surface of the water in the fish tanks, like duck weed, water lettuce, water hyacinth, water cress and water parsnip. The plants will reproduce naturally and survive off of nutrients in the water, sunlight and the carbon dioxide produced by the fish. In return, the plants oxygenate the water and could potentially be a source of food for the fish.

Geothermal heated swimming pool

There is already a 1,280 sq. ft. swimming pool operating in a building adjacent to the Recreation Centre in Faro. However, it only operates seasonally and Faro residents have expressed their desire for the pool to be opened all year round.

During the summer when the pool is open, it is heated by propane-fired boilers. This heating system also heats the changing rooms, showers and mechanical room at the pool.¹⁴³ Swimming pools are normally heated to between 25 and 28 °C. Installing a geothermal heat exchanger to heat the pool to this temperature would be beneficial for the community as it would provide another way for residents to exercise regularly in the winter months and is a measure to improve the quality of life in general.

Cost of Energy

Table 81: Residential energy prices in Faro

	Residential Service, non-government ¹⁴⁴	Residential Service, government ¹⁴⁵
Customer charge	\$14.65	\$18.47
Energy charge for the first 1,000 kWh	12.14 ¢/kWh	16.47 ¢/kWh
Energy charge between 1,001 – 2,500 kWh	12.82 ¢/kWh	17.47 ¢/kWh
Energy charge for energy in excess of 2,500 kWh	13.99 ¢/kWh	18.85 ¢/kWh

Table 82: General service energy prices in Faro

	General Service, non-government ¹⁴⁶	General Service, government - municipal ¹⁴⁷	General Service, government – federal & territorial ¹⁴⁸
Demand Charge for all kW of billing demand*	\$7.39 / kW	\$7.39 / kW	\$12.31 / kW
Energy charge for the first 2,000 kWh	10.00 ¢/kWh	10.00 ¢/kWh	13.81 ¢/kWh
Energy charge between 2,001 – 15,000 kWh	12.88 ¢/kWh	12.88 ¢/kWh	15.00 ¢/kWh
Energy charge between 15,001 – 20,000 kWh	15.68 ¢/kWh	15.68 ¢/kWh	20.00 ¢/kWh
Energy charge for energy in excess of 20,000 kWh	12.86 ¢/kWh	12.86 ¢/kWh	12.86 ¢/kWh

*where the billing demand may be estimated or measured and will be the greater of the following: A) The highest metered demand during the billing period. B) The highest metered demand during the 12 months ending with the current billing month, excluding the months April through September. C) The estimated demand. D) 5 kilowatts.

Table 83: Faro 2015 residential fuel prices¹⁴⁹

Month	Furnace Oil (¢/L)	Arctic Stove Oil (¢/L)	Propane (\$/500 gallon tank)
December	101.9	105.0	71.3
November	104.0	107.1	74.3
October	104.0	107.1	74.3
September	104.0	107.1	81.0
August	109.2	112.4	79.3
July	109.2	112.4	79.3
June	109.2	112.4	82.5
May	109.2	112.4	85.6

April	109.2	112.4	84.9
March	109.2	112.4	84.5
February	109.2	112.4	84.5
January	114.0	117.1	87.7

Infrastructure

Table 84: Faro infrastructure profile

List of Relevant Infrastructure	
Transportation Infrastructure	Tourism infrastructure
Highway access via Robert Campbell Highway	Hotels
Faro Airport with 4,000 ft. gravel runway	Restaurants
Float plane base at Johnson Lake	RV park & campground
Communication Infrastructure	Emergency Services
Cell reception: Latitude Wireless	Health Centre (2 nurses on staff)
High speed internet: NorthwesTel	Volunteer Ambulance on call 24 hours
Landline phone service: NorthwesTel	Medevac available 24 hours for emergencies
	Volunteer Fire on call 24 hours
	RCMP detachment
Business Infrastructure	Housing Infrastructure
Municipal government office	444 Private dwellings
Post office	167 Normally occupied dwellings
Conservation Office	120 Single detached houses
TD Bank	0 Apartments (5+ storeys)
Grocery/hardware store	0 Apartments (<5 storeys)
Gas station	10 Movable dwellings
Shopping and service stores	5 Semi-detached houses
Aviation services/airport	30 Row houses
Seniors complex	0 Duplexes
Educational Infrastructure	Recreation Infrastructure
Grade school up to grade 12	Community Centre
Public library inside the grade school	Gymnasium, squash courts
Yukon College Faro Campus	Summer swimming pool
	Indoor ice arena

Economics

Table 85: Faro 2015 Spatial Price Index (Whitehorse = 100)¹⁵⁰

Meat	93.0	Household Operations	112.5
Dairy/eggs	105.9	Health and Personal Care	111.5

Canadian Geothermal Energy Association
 PO Box 1462 Station M, Calgary, Alberta, T2P 2L6, Canada
 info@cangea.ca - www.cangea.ca



Fruit/vegetables	127.1	Gasoline	108.2
Bread/cereal	129.6	Cigarettes	101.5
Other Foods	132.2	Total Survey Items	113.3

Industries

The economic base of Faro includes government services in the federal, territorial, and municipal governments. Other industries include mining, construction, transportation, energy, and service sectors. Faro is transitioning from a mining economy to new opportunities. Mining is expected to contribute to the future of Faro’s economy through reclamation, exploration activities and mine clean up. For information about mining in this area, please consult the Ross River community profile in this report.

Haines Junction

Overview

Known to Yukoners as “The Junction,” Haines Junction is 2 hours east of Whitehorse along the Alaska Highway, and 3 hours north of Haines, Alaska on Haines road. It is located in the traditional territory of the self-governing Champagne and Aishihik First Nations (CAFN), making it the home of the Southern Tutchone people. The CAFN’s land claims agreement came into effect in 1995 and under this agreement, the CAFN has a role in the management of resources in their traditional territory.



Haines Junction, source: Google

Demographics

Table 86: Haines Junction 2011 demographics¹⁵¹

Classification	Village	Percent of population over 15	81.2%
Population in 2011	593	Total private dwellings	301
Population in 2006	589	Private dwellings occupied by usual residents	260
2006 to 2011 population change	+0.7%	Land area	34.49 km ²
Median age	41.6	Population density	17.2 / km ²

Geothermal Potential

Table 87: Temperature at depth & technical geothermal potential in Haines Junction

Depth in m	Temperature in °C	Technical Potential with 5%	Technical Potential with 14%	Technical Potential with 20%
------------	-------------------	-----------------------------	------------------------------	------------------------------

		recovery in MW	recovery in MW	recovery in MW
1,500	25	-	-	-
2,500	43	-	-	-
3,500	60	-	-	-
4,500	76	-	-	-

Haines Junction’s geothermal potential has to be classified as low. In order to produce electricity via a geothermal binary power plant production well would have to be drilled to a depth of roughly 4,500m. This seems not economical, especially when taking into account that Haines Junction is already part of the main hydroelectric grid.

Direct use applications are possible but the drilling costs are a limiting factor in Haines Junction. Well working horticulture applications usually use resources of about 40°C+. This temperature would be reached in a depth close to 2,5km.

Low temperature wells could be used for geexchange applications and heat individual homes/businesses in Haines Junction.

Cost of Energy

Table 88: Residential energy prices in Haines Junction

	Residential Service, non-government ¹⁵²	Residential Service, government ¹⁵³
Customer charge	\$14.65	\$18.47
Energy charge for the first 1,000 kWh	12.14 ¢/kWh	16.47 ¢/kWh
Energy charge between 1,001 – 2,500 kWh	12.82 ¢/kWh	17.47 ¢/kWh
Energy charge for energy in excess of 2,500 kWh	13.99 ¢/kWh	18.85 ¢/kWh

Table 89: General service energy prices in Haines Junction

	General Service, non-government ¹⁵⁴	General Service, government - municipal ¹⁵⁵	General Service, government – federal & territorial ¹⁵⁶
Demand Charge for all kW of billing demand*	\$7.39 / kW	\$7.39 / kW	\$12.31 / kW

Energy charge for the first 2,000 kWh	10.00 ¢/kWh	10.00 ¢/kWh	13.81 ¢/kWh
Energy charge between 2,001 – 15,000 kWh	12.88 ¢/kWh	12.88 ¢/kWh	15.00 ¢/kWh
Energy charge between 15,001 – 20,000 kWh	15.68 ¢/kWh	15.68 ¢/kWh	20.00 ¢/kWh
Energy charge for energy in excess of 20,000 kWh	12.86 ¢/kWh	12.86 ¢/kWh	12.86 ¢/kWh

*where the billing demand may be estimated or measured and will be the greater of the following: A) The highest metered demand during the billing period. B) The highest metered demand during the 12 months ending with the current billing month, excluding the months April through September. C) The estimated demand. D) 5 kilowatts.

Table 90: Haines Junction 2015 residential fuel prices¹⁵⁷

Month	Furnace Oil (¢/L)	Arctic Stove Oil (¢/L)	Propane (\$/500 gallon tank)
December	98.8	101.1	71.3
November	100.9	105.5	74.3
October	100.9	106.1	82.4
September	100.9	103.9	81.0
August	106.2	107.1	79.3
July	106.2	108.4	79.3
June	106.2	107.9	82.5
May	106.2	107.1	85.6
April	106.2	104.7	84.9
March	106.2	109.1	84.5
February	106.2	107.0	84.5
January	110.9	104.7	87.7

Infrastructure

Table 91: Haines Junction infrastructure profile

List of Relevant Infrastructure	
Transportation Infrastructure	Tourism infrastructure
Highway access via Alaska Highway	Hotels
Highway access via Haines Highway	Restaurants
Airport (chip-sealed tarmac runway)	RV park & campground
Communication Infrastructure	Emergency Services
Cell reception: Latitude Wireless	Health Centre (nurses on staff)
High speed internet: NorthwTel	Volunteer Ambulance on call 24 hours
Landline phone service: NorthwTel	Medevac available 24 hours for emergencies
	Volunteer Fire on call 24 hours

Business Infrastructure	Housing Infrastructure
St. Elias Convention Centre (250 seats)	RCMP detachment
Heavy equipment rentals	301 Private dwellings
Municipal government office	260 Normally occupied dwellings
Territorial offices	200 Single detached houses
TD Bank	0 Apartments (5+ storeys)
Grocery store	30 Apartments (<5 storeys)
Shopping and service stores	25 Movable dwellings
	0 Semi-detached houses
	0 Row houses
	5 Duplexes
Educational Infrastructure	Recreation Infrastructure
Grade school up to grade 12	Recreation Complex
Yukon College Haines Junction Campus	Indoor ice arena
Public Library	Summer pool
	Community Hall

Economics

Table 92: Haines Junction 2011* Spatial Price Index (Whitehorse = 100)¹⁵⁸

Meat	166.7	Household Operations	101.3
Dairy/eggs	117.8	Health and Personal Care	137.5
Fruit/vegetables	110.6	Gasoline	104.2
Bread/cereal	115.7	Cigarettes	114.5
Other Foods	109.3	Total Survey Items	116.0

*Haines Junction was without a grocery store from 2011 until December 2014. The most recent SPI data is from April, 2011.

Industries

The economic base of Haines Junction includes tourism, outdoor recreation and education. Haines Junction has made sustainable development a priority, as outlined in the 2007 Haines Junction Integrated Community Sustainability Plan. The sustainability goals laid out in 2007 were taken seriously, as the following achievements were mentioned in the 2013 Haines Junction Official Community Plan¹⁵⁹. The village of Haines Junction (VHJ) Council has begun using heat generated by the ice plant in the hockey arena to heat municipal buildings. The fire hall was also retrofitted, resulting in a 50% reduction in the volume of fuel used to heat the building. Council is considering reviewing other municipal buildings in a similar manner. In 2013 the VHJ Council, the

Canadian Geothermal Energy Association
PO Box 1462 Station M, Calgary, Alberta, T2P 2L6, Canada
info@cangea.ca - www.cangea.ca



Champagne and Aishihik First Nations, and the Dakwakada Development Corporation were investigating the feasibility of utilizing local biomass to produce electrical power and/or district heat in a sustainable and environmentally friendly process. Two noteworthy economic policies laid out in this document to promote economic development were:

- Promote economic opportunities for the area, placing particular emphasis on encouraging year-round tourism activities and employment opportunities in the municipality.
- Encourage “clean and green” industry and/or commercial ventures which will help diversify the economic base and promote a sustainable economy

Geothermal projects provide clean electricity and heat year-round that can be used in applications ranging from hot spring pools to greenhousing to brewing craft beer. Haines Junction’s history in sustainable development, and forward-looking attitude makes it a community to consider for future renewable energy developments.

Mayo

Overview

Mayo is located 4 hours north of Whitehorse and 2 hours east of Dawson city. Mayo is within the traditional territory of the First Nation of Na-Cho Nyäk Dun (FNNND) and represents most of the northerly community of the Northern Tutchone language and culture group. The Na-Cho Nyäk Dun has a membership of 602, and is a self-governing First Nation. They are actively involved with the Mayo community to promote a better, healthier lifestyle for its future generations and a strong economy based on its rich natural resources.



Mayo, source: Google

Demographics

Table 93: Mayo 2011 demographics¹⁶⁰

Classification	Village	Percent of population over 15	84.5%
Population in 2011	226	Total private dwellings	134
Population in 2006	248	Private dwellings occupied by usual residents	115
2006 to 2011 population change	-8.9%	Land area	1.06 km ²
Median age	45.1	Population density	213.2 / km ²

Geothermal Potential

Table 94: Temperature at depth & technical geothermal potential in Mayo

Depth in m	Temperature	Technical	Technical	Technical
------------	-------------	-----------	-----------	-----------

	in °C	Potential with 5% recovery in MW	Potential with 14% recovery in MW	Potential with 20% recovery in MW
1,500	31	-	-	-
2,500	53	-	-	-
3,500	73	-	-	-
4,500	94	4.17	11.68	16.68

Mayo is part of the main hydroelectric grid and its geothermal potential has to be characterized as low. The temperature at a depth of 3,500m reaches only 73°C. Possible direct use applications for Mayo are the heating of buildings in town and the Dublin Gulch Mine facilities. In addition to this geothermally heated greenhouses could provide locally harvested produce. With 66% above Whitehorse’s average, the fruit and vegetable prices in Mayo are very high, even for rural Yukon standards and could use price regulation via local horticulture.

Direct use applications are possible but the drilling costs are a limiting factor in Mayo. Well working horticulture applications usually use resources of about 40°C+. This temperature would be reached in a depth close to 2,5km.

Cost of Energy

Table 95: Residential energy prices in Mayo

	Residential Service, non-government ¹⁶¹	Residential Service, government ¹⁶²
Customer charge	\$14.65	\$18.47
Energy charge for the first 1,000 kWh	12.14 ¢/kWh	16.47 ¢/kWh
Energy charge between 1,001 – 2,500 kWh	12.82 ¢/kWh	17.47 ¢/kWh
Energy charge for energy in excess of 2,500 kWh	13.99 ¢/kWh	18.85 ¢/kWh

Table 96: General service energy prices in Mayo

	General Service, non-government ¹⁶³	General Service, government - municipal ¹⁶⁴	General Service, government – federal & territorial ¹⁶⁵
--	--	--	--

Demand Charge for all kW of billing demand*	\$7.39 / kW	\$7.39 / kW	\$12.31 / kW
Energy charge for the first 2,000 kWh	10.00 ¢/kWh	10.00 ¢/kWh	13.81 ¢/kWh
Energy charge between 2,001 – 15,000 kWh	12.88 ¢/kWh	12.88 ¢/kWh	15.00 ¢/kWh
Energy charge between 15,001 – 20,000 kWh	15.68 ¢/kWh	15.68 ¢/kWh	20.00 ¢/kWh
Energy charge for energy in excess of 20,000 kWh	12.86 ¢/kWh	12.86 ¢/kWh	12.86 ¢/kWh

*where the billing demand may be estimated or measured and will be the greater of the following: A) The highest metered demand during the billing period. B) The highest metered demand during the 12 months ending with the current billing month, excluding the months April through September. C) The estimated demand. D) 5 kilowatts.

Table 97: Mayo 2015 residential fuel prices¹⁶⁶

Month	Furnace Oil (¢/L)	Arctic Stove Oil (¢/L)	Propane (\$/500 gallon tank)
December	112.2	112.3	71.3
November	115.3	115.6	74.3
October	114.2	116.8	82.4
September	114.9	115.5	81.0
August	119.0	117.2	79.3
July	119.0	117.7	79.3
June	119.0	118.3	82.5
May	118.0	117.4	85.6
April	119.0	120.5	84.9
March	118.9	120.0	84.5
February	119.0	117.8	84.5
January	117.6	116.7	87.7

Infrastructure

Table 98: Mayo infrastructure profile

List of Relevant Infrastructure	
Transportation Infrastructure	Tourism infrastructure
Highway access via Silver Trail Mayo Airport (gravel airstrip)	Hotels Restaurants RV park & campground
Communication Infrastructure	Emergency Services
Cell reception: Latitude Wireless High speed internet: NorthwesTel Landline phone service: NorthwesTel	Health Centre (3 nurses on staff) Volunteer Ambulance on call 24 hours Medevac available 24 hours for

	emergencies Volunteer Fire on call 24 hours RCMP detachment
Business Infrastructure	Housing Infrastructure
Municipal government office	134 Private dwellings
Na-Cho Nyäk Dun Development Corporation	115 Normally occupied dwellings
TD Bank	105 Single detached houses
Convenience store	0 Apartments (5+ storeys)
Laundromat	0 Apartments (<5 storeys)
Gas Station	0 Movable dwellings
	0 Semi-detached houses
	5 Row houses
	0 Duplexes
Educational Infrastructure	Recreation Infrastructure
Grade school up to grade 12	Community Hall
Yukon College Mayo Campus	Hockey arena
Public library	Fitness centre/gymnasium
	Curling facilities

Economics

Table 99: Mayo 2015 Spatial Price Index (Whitehorse = 100)¹⁶⁷

Meat	124.5	Household Operations	117.9
Dairy/eggs	119.1	Health and Personal Care	110.5
Fruit/vegetables	166.5	Gasoline	109.3
Bread/cereal	116.4	Cigarettes	114.6
Other Foods	115.2	Total Survey Items	119.4

Industries

The economic base of Mayo includes government services in the federal, territorial, First Nation and municipal governments. Private industries primarily include mining, construction, transportation, and the service industry. Mining activity in the region is one of the largest economic drivers. There is a 15.1 MW hydro facility near Mayo that provides opportunities for skilled labour in the energy industry.

Dublin Gulch Mine

The Dublin Gulch project is located 85km north northwest of Mayo. It can be accessed by road and is owned by the Victoria Gold Corporation, which proposed to operate an

open pit gold mine on the property. The property lies within the traditional territory of the Na-Cho Nyak Dun First Nation. A Cooperation and Benefits Agreement was signed in October 2011. Access to the electrical grid is currently not available but Victoria Gold Corporation is planning in connecting the project site to the grid via a 43km long 69kV power line. The Eagle gold project on the property received approval to start construction in 2013 and currently a 100-person camp is operational at site. During the construction period between 350 and 400 workers will be employed. The mine has an estimated life span of roughly ten years. During its operational phase the mine is expected to produce 212,000 ounces of gold annually.

Table 100: Dublin Gulch mine based on preliminary economic assessment – June 2014¹⁶⁸

Ownership	100% Victoria Gold Corporation
Resource	6.3 million ounces of gold (indicated and inferred)
Primary Metals	Gold
Process	Heap leach
Mine Type	Open pit
Mine Life	10 years
Employees	350 - 400 (peak construction)
Location	85km north northeast of Mayo, YK
Infrastructure	Good road access, upgrade of a 23km access road
Power	43km from Yukon power grid (to be connected)
Status	Engineering / Permitting

Bellekeno Mine

The Bellekeno property is owned by Alexco Resource Corporation. It was Canada’s only operating primary silver mine from 2011 to 2013. Alexco has suspended the mine’s operations in 2013 in order to reduce costs and to reposition the project for more sustainable operations.¹⁶⁹ The mine is located in the Keno Hill Silver District, around 40 km from Mayo.

Mount Lorne

Overview

Mount Lorne is a rural residential hamlet covering an area of 160 km² and is located less than 1 hour south of Whitehorse along the Klondike Highway. Mount Lorne is situated in the traditional territories of two self-governing First Nations: the Carcross/Tagish First Nation and the Kwanlin Dun First Nation. An elected Local Advisory Council (LAC) advises on the governance of the community and the Lorne Mt. Community Association serves the social and recreational needs of the Hamlet.



Mount Lorne, source: Google

Demographics

Table 101: Mount Lorne 2011 demographics¹⁷⁰

Classification	Hamlet	Percent of population over 15	84.1%
Population in 2011	408	Total private dwellings	187
Population in 2006	370	Private dwellings occupied by usual residents	170
2006 to 2011 population change	+10.3%	Land area	160.24 km ²
Median age	45.8	Population density	2.5 / km ²

Geothermal Potential

Table 102: Temperature at depth & technical geothermal potential in Mount Lorne

Depth in m	Temperature in °C	Technical Potential with 5% recovery in MW	Technical Potential with 14% recovery in MW	Technical Potential with 20% recovery in MW
1,500	47	-	-	-

2,500	78	0.45	1.36	1.80
3,500	96	4.71	13.19	18.84
4,500	114	5.24	14.67	20.96

The temperature profile of Mount Lorne suggests that the binary power plant cut off temperature is reached between 2300 and 2,500m depth. Electricity production from binary power plants does not seem profitable, as Mount Lorne is part of the hydroelectric grid.

The evaluation of project costs for Mount Lorne is not 100% accurate. CanGEA has undertaken calculations for binary power plant costs in the past and the results of these calculations are used in this report. The assumptions used for these calculations are not identical to the real local circumstances.

CanGEA's archive states the cost for a 1 MW_e/13 MW_t CHP project set in a Wet Fractured Rock environment in the Canadian North to be roughly \$31 million. A cost table can be found in Table 103. The actual cost for Mount Lorne would likely be slightly higher, as the drilling depth is estimated to be deeper than in the calculatory example (2,100m).

Table 103: Cost table for an exemplary 1 MW_e/13 MW_t CHP project in northern Canada (Wet Fractured Rock environment).

Cost Category	Cost in million \$
Exploration and Drilling	18.0
Well Pumps	1.7
ORC Unit	4.0
Facility	2.6
Construction	0.8
Materials	0.7
Engineering	0.5
Contingency	2.8

Assuming a capacity factor of 0.9, a recovery factor high enough to supply the 1 MW binary unit, the potential to sell all produced electricity (7,884,000 kWh/a), constant achievable prices, a project lifetime of 50 years, a Weighted Average Cost of Capital (WACC) of 8%, construction cost payable up front and disregarding annual maintenance

cost, the break even price for power production only is approximately \$0.30/kWh. The break-even price can be lowered / the NPV can be increased by adding a cascaded heat system that could be used for additional profit generation.

Due to the large area that is populated in the case of Mt Lorne, good locations for direct use applications are scarce, since proximity to consumers can be of great importance.

It is assumed that the temperature of the geothermal fluid leaving the binary power plant will decrease by about 17 °C from the incoming fluid, as this has been the case for other binary power plants of similar size. The outlet temperature should allow for further cascaded use of the fluid, which may be economically beneficial and is strongly suggested for Mt. Lorne. Along with many other northern communities, district heating, horticulture and additional direct-use applications of geothermal energy may be economically viable for Mt. Lorne.

Geothermal Greenhouses

Horticultural applications could create value by providing locally grown fruits and vegetables for consumption by the Mt. Lorne community. Geothermal power can be used to not only heat a greenhouse, but also to supply the building with electricity for artificial lighting to assist in the optimal growth of plants. A greenhouse powered by geothermal energy could make a true year-round operation possible in Mt. Lorne and support the community with fresh produce at any time of the year.

Only 37.3% of Yukon residents reported fruit and vegetable consumption of 5 or more times per day in 2008.¹⁷¹ Initially, a design of a greenhouse powered by geothermal energy that could produce spinach all-year round for the population of Mt. Lorne was considered. Spinach was chosen for this design as an example of what could be grown since it is a nutrient dense vegetable, with one serving providing nutrients that include 5% of a person's daily iron and 56% of a person's daily recommended vitamin A intake. It is also a versatile vegetable that can be worked into various meals or snacks, as well as eaten raw or frozen to be consumed at a later date.

The greenhouse is designed to provide fresh vegetables all year round to the Mt. Lorne community during 6 harvests, since spinach takes about 8 weeks until it can be harvested. To yield one servings of spinach per day, based on the Canada Food Guide, to each resident of Mt. Lorne over a two week long period after each harvest a greenhouse would need to have approximately 1,250 sqft of growing area. This area does neither account for extra space needed to maneuver in the greenhouse nor for space for packaging and storing the produce. As it is assumed that the plants will take up 60% of the total greenhouse area, the final space needed for the operation of the greenhouse is 2,083 sqft. A harvest of this size would provide the possibility for each resident of Mt Lorne to consume fresh vegetables at least once per day during two weeks following each harvest. As the yield per square metre and the suggested serving size differ for each fruit and vegetable, the overall size of the greenhouse changes with its produce selection. In order to provide a serving of beets per day for every resident of Mt. Lorne the greenhouse would need a floor space of 3,240 sqft. Tomatoes can have a very high yield per square metre. Therefore it is suggested to add floor space to the greenhouse in order be able to supply fresh tomatoes on a regular basis to the residents of Mt Lorne. A growing area of 270 sqft should suffice to produce over 20 servings of tomatoes per resident each year. An overall size of 2,500 sqft (1,500 sqft growing area) is suggested.

Tomatoes and beets have a similar growth time to spinach, are also nutrient dense and could be cultivated during another one of the 6 possible annual harvest periods in this greenhouse. A 2.500 sqft greenhouse could lead to the cultivation of tomatoes to provide three servings of vegetables to each resident of Mt. Lorne and the farming of enough beets to fulfill one serving of vegetables for each resident of the community over a period of a week following the harvest.

Table 104: Estimated vegetable production for 1,500 sqft of growing space – Mt. Lorne

Product	Grams per 1,500 sqft	Grams per serving	Total servings per 1,500 sqft
Spinach	222,400	32,5	6,843
Tomato	6,950,000	137	51,481
Beets	312,750	71	4,405

In cold climates, it is of importance to collect as much sunlight as possible while minimizing the negative effect that shadow has on crop growth. A length to width ratio of at least 2:1 is recommended while orienting the structure in an east-west direction. Due to the high latitude of any location within the Yukon the northern side of a greenhouse will not collect direct sunlight. The outer surfaces that are able to utilize the sun’s light and heat will be made of 3-wall polycarbonate as it can withstand high winds and a considerable snow load while offering good insulation values. The surfaces of the greenhouse that will not be in direct contact with the sunlight will be made of an aluminum frame with insulation between the inner and outer walls. This will further minimize heat loss, allowing for a more efficient heat management in the greenhouse. The whole frame of the greenhouse can be made out of aluminum, as it is the dominant material on the market. Aluminum offers multiple advantages over wood or steel, as it is longer lasting and relatively light. Additionally, the inclination on the south facing roof should be chosen in a way that maximizes the natural solar heat gain. For the Mt. Lorne Greenhouse, a roof inclination of 45 degrees will be used to allow for this solar heat gain and easy removal of materials that may cover the roof such as snow.

With these design considerations in mind, a preliminary design for the greenhouse can be obtained, allowing for a rough cost estimate to be made. The greenhouse will be a long rectangular prism of 2:1 length to width with a triangular roof. This design coupled with a required floor space of 2,500 sqft produces a greenhouse with the following dimensions.

Table 105: Exemplary greenhouse design – Mt. Lorne

Dimension	ft
Length	71
Width	35
Height of north/south wall	10
Height of peak	29

Table 106: Exemplary greenhouse design – surface areas - Mt. Lorne

Dimension	ft
South Wall	707
East Wall	860

West Wall	860
North Wall	707
South Roof	2,379
North Roof	2,379
Total	7,893

The east, west and south walls as well as the south facing roof will all be made out of 3-wall polycarbonate as they will be the walls capable of using the sun’s heat and light. The north wall and north facing roof will be made out of aluminum siding/roofing with layers of insulation on the inner walls of the material to reduce heat loss. Prices are averaged prices obtained by selective market research. Real prices in Mt. Lorne can differ.

Table 107: Exemplary greenhouse design – material cost - Mt. Lorne

Material	Amount (ft ²)	Cost (\$/ft ²)	Total cost (\$)
Aluminum framing	520	2.5	1,301
Polycarbonate	4,806	1.99	9,564
Insulation	3,087	1.5	4,630
Aluminum roofing	2,379	3.99	9,494
Total			24,989

In order for the greenhouse to be operational during the whole year, it must be able to maintain an inside temperature of minimum 15 °C while the outside temperature is -22 °C, which is the estimated average low for the coldest month in Mt. Lorne. In these conditions, a minimum heat rating of 42 kW is required. This will be provided from the power plant outlet stream. A 40 kW diesel generator, which would be sufficient for most times running on full load would require 15.1 litres of diesel per hour to provide sufficient heating in these harsh conditions. This equates to 362 litres of diesel fuel per day, costing roughly \$413 at \$1.14 per litre. As temperatures can drop below the estimated average low, a backup heating system can be installed to avoid frost damage.

It is advisable to build the greenhouse in a location close to the hypothetical binary power plant to ensure the geothermal fluid flowing from the plant to the greenhouse experiences minimal heat loss during the transport. This location should also be in close

proximity to the community to allow for easy access and operation. If there is existing infrastructure near a suitable building site in Mt. Lorne, the greenhouse could be attached to a building, which will reduce the initial construction costs of the greenhouse, as well as to minimize its heat loss.

The next steps in the design of the greenhouse are to decide on lighting and piping. The lighting system and the pipes should be laid out evenly in order to maintain a uniform heat distribution within the greenhouse. Depending on the ground area of the greenhouse, two inflow pipes should be used, which transport the water in alternating directions in order to minimize the effect the heat loss along the piping system has on the uniformity of the temperature distribution within the building. The minimum temperature of the greenhouse should not drop below 0°C. In order to minimize heat loss when entering the greenhouse, a heated arctic entry should be considered. When designing the pipe and lighting layout it is important that it is closely linked to the alignment of the crops being grown. Between crop rows, tracks need to be wide enough to ensure effective harvesting and allowing maintenance on the heating and lighting system.

The northern latitude of Mt. Lorne results in widely varying daylight periods throughout the year. The longest day of the year averages approximately 18 hours long, and the shortest day of the year is roughly 5 hours long. This variation in daylight hours creates challenges for greenhouse operations in Mt. Lorne, and the greenhouses must have an LED lighting system in place to accommodate for these varying amounts of sun. The lighting systems used in the Alaskan Chena Hot Springs greenhouses are designed specifically for each crop in order to be as energy efficient as possible. Similarly, greenhouses constructed in Mt. Lorne should be energy conscious with their lighting system, using LED lighting for their energy efficiency, and to accommodate for fluctuating daylight hours throughout the year.

Due to the low soil temperatures in a northern environment like Mt. Lorne, the use of raised planting beds is advisable. Additionally, raised beds can make harvesting the produce easier as the beds are raised to working level.

Canadian Geothermal Energy Association
PO Box 1462 Station M, Calgary, Alberta, T2P 2L6, Canada
info@cangea.ca - www.cangea.ca



As plants need water and fertilizer for their growth, choices on irrigation systems and fertilizer selection have to be made. For Mt. Lorne a fertigation system would be preferable, which means that a fertilizer water solution is used. This system works on a drip irrigation basis with added root moisture sensors, which ensure an optimal moisture and nutrient level at all times.

Ventilation systems offer effective temperature adjustment with little effort. It is advisable to install an automated system, which regulates the indoor temperature through automated opening and closing of vents.

This residual temperature after the greenhouse heating process is likely high enough to be used for further cascaded applications such as drying fresh food products, heated storage or other types of public facilities, district heating and the heating of public swimming pools. These applications that could be beneficial to Mt. Lorne, in addition to being powered in an affordable and efficient way by geothermal power will be discussed in further detail below.

Drying of Greenhouse products

The drying of food is an application that is can be particularly meaningful to northern communities, since it is a way to preserve fruits and vegetables that are not abundant in these climates for future consumption. Though it is important to note that dried fruits and vegetables cannot replace their fresh versions since there is some nutrient loss caused by dehydration, these products can be used to supplement diets and have a high caloric density with dried fruits and vegetables containing up to five time more calories than their fresh counterparts. A food drying facility in Mt. Lorne could use the excess heat that is available after heating the greenhouse to heat up the drying chamber. A de-humidifier and an air pump can be electrically powered and should be used in wet weather. Good primary drying conditions require a relative humidity between 20% and 50% and an air velocity of approximately 3 m/s. For perfect results a second drying process with higher temperatures and lower air velocity can be added.

Space heating

The scarce settlement structure in part of Mt. Lorne makes a district heating system not a potentially attractive application for the community. Nevertheless, Mt. Lorne could be home to geothermally heated community buildings that could be used for community social events and storage, among many other potential uses. A space heated to room temperature could be used in part for animal husbandry, more specifically the raising of chickens for eggs and meat throughout the winter. This could be an important endeavour for a community like Mt. Lorne that cannot keep animals all year round outdoors due to its cold climate.

Aquaculture

Different species of fish could be raised for human consumption all year round in Mt. Lorne through the use of aquaculture powered and heated by geothermal energy.

Some examples of fish that are native to this region are Arctic grayling, northern pike and lake trout. For this example, an aquaculture system for the farming of rainbow trout, a commonly cultured fish that cannot already be found in Mt. Lorne is suggested. Rainbow trout is a good source of protein with an average marketable size fish, between 0.5 to 1.0 kg and a good source of Omega-3 essential acids. Trout will exhibit optimum growth at 17°C, though they can survive between temperatures of 0°C to 27°C. This species of trout will take about 6 to 8 months to reach their optimal market size.

For fish of 500g in size, the tank should be able to maintain a flow through of 5 l/min/m³ and can produce about 50 fish per m³. For a community like Mt. Lorne a reasonably large tank could be built and the fish produced could be frozen for later consumption or to be sold to nearby communities. To complete all steps of fish farming in Mt. Lorne, hatching and rearing tanks will also need to be constructed. The location of Mt. Lorne close to a freshwater source is ideal since this water could be used to fill the tanks in which to grow the trout.

General assumptions can be made about the piping that will be required for the heat exchanger and their location in relation to the tank. For example, steel or FRP

(Fibreglass Reinforced Plastic) piping could be used to carry the hot fluid to and from the heat exchanger and PVC piping could be used to circulate the warm fluid through the tank. A method to reduce heat loss due to the cold northern temperatures and evaporation all year round from the tanks would be to cover them with a roof structure similar to that of a greenhouse and heat the space surrounding the tank.

One way to simplify the aquaculture system is to grow vegetation on the surface of the water that will enable some feeding of the trout, as well as to filter the water in the tanks. For example, numerous floating and rooted water plants could be grown on the surface of the water in the fish tanks, like duck weed, water lettuce, water hyacinth, water cress and water parsnip. The plants will reproduce naturally and survive off of nutrients in the water, sunlight and the carbon dioxide produced by the fish. In return, the plants oxygenate the water and could potentially be a source of food for the fish.

Cost of Energy

Table 108: Residential energy prices in Mount Lorne

	Residential Service, non-government ¹⁷²	Residential Service, government ¹⁷³
Customer charge	\$14.65	\$18.47
Energy charge for the first 1,000 kWh	12.14 ¢/kWh	16.47 ¢/kWh
Energy charge between 1,001 – 2,500 kWh	12.82 ¢/kWh	17.47 ¢/kWh
Energy charge for energy in excess of 2,500 kWh	13.99 ¢/kWh	18.85 ¢/kWh

Table 109: General service energy prices in Mount Lorne

	General Service, non-government ¹⁷⁴	General Service, government - municipal ¹⁷⁵	General Service, government – federal & territorial ¹⁷⁶
Demand Charge for all kW of billing demand*	\$7.39 / kW	\$7.39 / kW	\$12.31 / kW
Energy charge for the first 2,000 kWh	10.00 ¢/kWh	10.00 ¢/kWh	13.81 ¢/kWh
Energy charge between 2,001 – 15,000 kWh	12.88 ¢/kWh	12.88 ¢/kWh	15.00 ¢/kWh
Energy charge between	15.68 ¢/kWh	15.68 ¢/kWh	20.00 ¢/kWh

15,001 – 20,000 kWh

Energy charge for energy in excess of 20,000 kWh	12.86 ¢/kWh	12.86 ¢/kWh	12.86 ¢/kWh
---	-------------	-------------	-------------

*where the billing demand may be estimated or measured and will be the greater of the following: A) The highest metered demand during the billing period. B) The highest metered demand during the 12 months ending with the current billing month, excluding the months April through September. C) The estimated demand. D) 5 kilowatts.

Table 110: Mount Lorne 2015 residential fuel prices

Month	Furnace Oil (¢/L)	Arctic Stove Oil (¢/L)	Propane (\$/500 gallon tank)
December	No Data	No Data	No Data
November	No Data	No Data	No Data
October	No Data	No Data	No Data
September	No Data	No Data	No Data
August	No Data	No Data	No Data
July	No Data	No Data	No Data
June	No Data	No Data	No Data
May	No Data	No Data	No Data
April	No Data	No Data	No Data
March	No Data	No Data	No Data
February	No Data	No Data	No Data
January	No Data	No Data	No Data

Infrastructure

Table 111: Mount Lorne infrastructure profile

List of Relevant Infrastructure	
Transportation Infrastructure	Tourism infrastructure
Highway access Klondike Highway	Bed and Breakfast
Served by Erik Nielson Whitehorse International Airport	Cafe
	Community Centre available to rent
Communication Infrastructure	Emergency Services
Cell reception: Latitude Wireless	No health facility – must travel to Whitehorse for treatment
High speed internet: NorthwesTel	Ambulance out of Whitehorse
Landline phone service: NorthwesTel	Medevac available 24 hours for emergencies
	Volunteer Fire on call 24 hours
	RCMP detachment
Business Infrastructure	Housing Infrastructure
Lorne Mt. Community Centre	187 Private dwellings
Local Advisory Council	170 Normally occupied dwellings
Lorne Mt. Community Association	165 Single detached houses

Full business services nearby in Whitehorse	0 Apartments (5+ storeys) 0 Apartments (<5 storeys) 5 Movable dwellings 0 Semi-detached houses 0 Row houses 0 Duplexes
Educational Infrastructure	Recreation Infrastructure
School bus service into Whitehorse	Community Centre

Economics

Table 112: Mount Lorne 2015 Spatial Price Index (Whitehorse = 100)

Meat	No Data	Household Operations	No Data
Dairy/eggs	No Data	Health and Personal Care	No Data
Fruit/vegetables	No Data	Gasoline	No Data
Bread/cereal	No Data	Cigarettes	No Data
Other Foods	No Data	Total Survey Items	No Data

Industries

The economic base of Mount Lorne includes small local businesses, private contractors, home businesses, outdoor adventure, bed and breakfast, and trades related work. Close proximity to Whitehorse means that the benefits of a big city are less than a 1-hour commute.

Old Crow

Overview

Old Crow is the most northern community in Yukon and cannot be accessed by road. Situated on the banks of the Porcupine and Old Crow Rivers, it is 120 km north of the Arctic Circle and 100 km east of the Alaska border. It is home to the Vuntut Gwitchin First Nation, which signed a land claim and self-government agreement in 1995. The First Nation provides the majority of government and municipal services. The main access to Old Crow is by airplane; the only other access is through the river system.

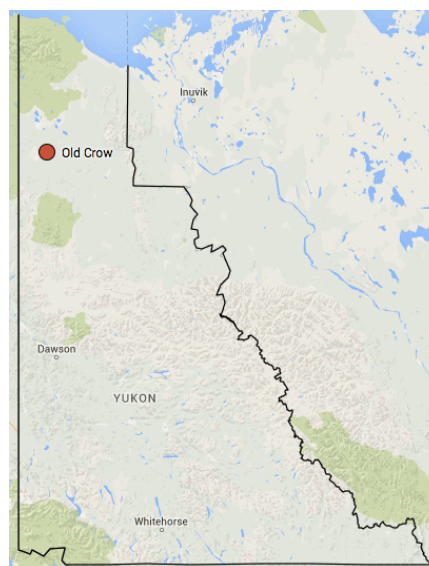

Demographics

Table 113: Old Crow 2011 demographics¹⁷⁷

Old Crow, source: Google

Classification	Settlement	Percent of population over 15	78.0%
Population in 2011	245	Total private dwellings	162
Population in 2006	253	Private dwellings occupied by usual residents	109
2006 to 2011 population change	-3.2%	Land area	14.17 km ²
Median age	35.1	Population density	17.2 / km ²

Geothermal Potential

Table 114: Temperature at depth & technical geothermal potential in Old Crow

Depth in m	Temperature in °C	Technical Potential with 5% recovery in MW	Technical Potential with 14% recovery in MW	Technical Potential with 20% recovery in MW
1,500	17	-	-	-

2,500	30	-	-	-
3,500	42	-	-	-
4,500	53	-	-	-

Old Crow’s geothermal potential has to be qualified as very low. The data shows that electricity production is not possible down to a depth of 4,500m and lower. Even for low temperature direct use applications the temperature profile does not look promising.

Members of the Old Crow community took part in the geothermal survey and identified high food prices and heating as the main concerns of the community. Unfortunately geothermal energy is unlikely to be part of the solution to these problems.

Currently, nearly all electricity is provided to Old Crow by a 0.7 MW diesel facility with fuel that is flown in. The John Tizya Cultural Centre and the new research centre have rooftop solar arrays and sell any excess power that they generate back to the community grid. The high



12.1 kW solar array on the Old Crow research facility, source: kobayashi + zedda architects

cost of transporting and burning diesel makes solar energy viable for Old Crow. The Vuntut Gwichin First Nation (VGFN) outlined in its 2013 Old Crow Community Plan that “the VGFN may seek partnership with Yukon Electrical Company to pursue alternative energy use options, including the use of wind turbines, waste heat and district heating, and will encourage the adoption of energy conservation practices in all capital projects.¹⁷⁸” The community since investigated the feasibility of wind power, but found that it would not be cost effective¹⁷⁹. Old Crow’s high cost of energy and desire to lower their dependence on diesel make it a potential location for future renewable energy development.

Cost of Energy

Old Crow is an off-grid community; electricity is generated locally from a 0.7 MW diesel facility. There is no road access to Old Crow and fuel must be flown in.

Table 115: Residential energy prices in Old Crow

	Residential Service, non-government ¹⁸⁰	Residential Service, government ¹⁸¹
Customer charge	\$14.65	\$18.47
Energy charge for the first 1,000 kWh	12.14 ¢/kWh	16.47 ¢/kWh
Energy charge between 1,001 – 2,500 kWh	12.82 ¢/kWh	17.47 ¢/kWh
Energy charge for energy in excess of 2,500 kWh	30.77 ¢/kWh	41.45 ¢/kWh

Table 116: General service energy prices in Old Crow

	General Service, non-government ¹⁸²	General Service, government - municipal ¹⁸³	General Service, government – federal & territorial ¹⁸⁴
Demand Charge for all kW of billing demand*	\$7.39 / kW	\$7.39 / kW	\$12.31 / kW
Energy charge for the first 2,000 kWh	10.00 ¢/kWh	10.00 ¢/kWh	13.81 ¢/kWh
Energy charge between 2,001 – 15,000 kWh	12.88 ¢/kWh	12.88 ¢/kWh	15.00 ¢/kWh
Energy charge between 15,001 – 20,000 kWh	15.68 ¢/kWh	15.68 ¢/kWh	20.00 ¢/kWh
Energy charge for energy in excess of 20,000 kWh	31.72 ¢/kWh	31.72 ¢/kWh	31.72 ¢/kWh

*where the billing demand may be estimated or measured and will be the greater of the following: A) The highest metered demand during the billing period. B) The highest metered demand during the 12 months ending with the current billing month, excluding the months April through September. C) The estimated demand. D) 5 kilowatts.

Table 117: Old Crow 2015 residential fuel prices

Month	Furnace Oil (¢/L)	Arctic Stove Oil (¢/L)	Propane (\$/500 gallon tank)
December	No Data	No Data	No Data
November	No Data	No Data	No Data
October	No Data	No Data	No Data
September	No Data	No Data	No Data

August	No Data	No Data	No Data
July	No Data	No Data	No Data
June	No Data	No Data	No Data
May	No Data	No Data	No Data
April	No Data	No Data	No Data
March	No Data	No Data	No Data
February	No Data	No Data	No Data
January	No Data	No Data	No Data

Infrastructure

Table 118: Old Crow infrastructure profile

List of Relevant Infrastructure	
Transportation Infrastructure	Tourism infrastructure
Gravel airstrip maintained year round River access is possible in summer months No road access	Bed and Breakfast
Communication Infrastructure	Emergency Services
Cell reception: Latitude Wireless High speed internet: NorthwesTel Landline phone service: NorthwesTel	Health Centre (2 nurses on staff) Air ambulance from Whitehorse (travel time of 3 hours) Medevac available 24 hours for emergencies Volunteer fire service RCMP detachment
Business Infrastructure	Housing Infrastructure
Post Office Bank Gas Services Grocery/hardware store Vuntut Development Corporation	162 Private dwellings 109 Normally occupied dwellings 90 Single detached houses 0 Apartments (5+ storeys) 0 Apartments (<5 storeys) 0 Movable dwellings 15 Semi-detached houses 0 Row houses 0 Duplexes
Educational Infrastructure	Recreation Infrastructure
Grade school up to grade 12 Public library inside the grade school Yukon College Old Crow Campus	Youth Centre Heritage Hall Ball diamond Skateboard park Covered Arena

Economics

Table 119: Old Crow 2015 Spatial Price Index (Whitehorse = 100)¹⁸⁵

Meat	116.3	Household Operations	212.6
Dairy/eggs	145.5	Health and Personal Care	114.7
Fruit/vegetables	177.8	Gasoline	No Data
Bread/cereal	170.3	Cigarettes	No Data
Other Foods	226.4	Total Survey Items	180.5

Industries

The economic base of Old Crow includes government services from the federal, territorial, and First Nation governments. The Vuntut Development Corporation has successfully created employment and revenue through its various business ventures. The subsistence economy is an essential component of the Old Crow economy and every day life in the community.

Pelly Crossing

Overview

Pelly Crossing is located 2.5 hours north of Whitehorse, and 2.5 hours south east of Dawson City along the Klondike Highway. It is home to the Northern Tutchone people of the Selkirk First Nation. The Selkirk First Nation signed a land claim and self-government agreement in 1997, making them the seventh self-governing First Nation in the Yukon. Pelly Crossing is approximately half way between Yukon’s two largest cities: Whitehorse and Dawson City, making it a popular stopping point for travelers along the Klondike Highway.

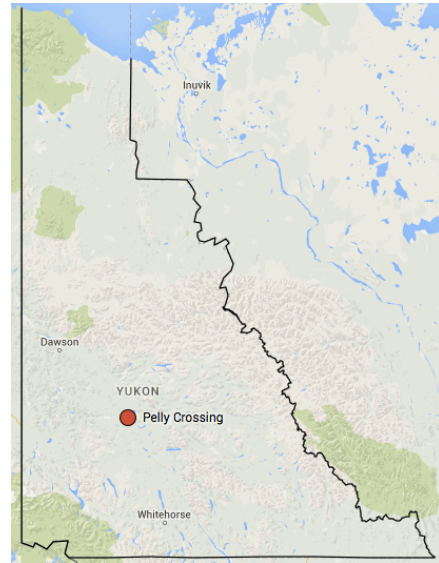

Pelly Crossing, source: Google

Demographics

Table 120: Pelly Crossing 2011 demographics¹⁸⁶

Classification	Settlement	Percent of population over 15	81.5%
Population in 2011	336	Total private dwellings	145
Population in 2006	296	Private dwellings occupied by usual residents	132
2006 to 2011 population change	+13.5%	Land area	32.43 km ²
Median age	38.3	Population density	10.4 / km ²

Geothermal Potential

Table 121: Temperature at depth & technical geothermal potential in Pelly Crossing

Depth in m	Temperature in °C	Technical Potential with 5% recovery	Technical Potential with 14% recovery	Technical Potential with 20% recovery

		in MW	in MW	in MW
1,500	32	-	-	-
2,500	55	-	-	-
3,500	76	-	-	-
4,500	97	4.41	12.35	17.64

Pelly Crossing is part of the main hydroelectric grid and has limited geothermal potential. The binary cut off temperature is reached close to 3,500m depth, which means that drilling costs would be fairly high in comparison to other communities. Due to the close proximity of the Minto mine, the Pelly Crossing area has a high demand for heat, which could partially be met with low temperature direct use applications. It is to state though, that the temperature profile would make an economical operation challenging, as drilling cost would accumulate substantially.

Cost of Energy

Table 122: Residential energy prices in Pelly Crossing

	Residential Service, non-government ¹⁸⁷	Residential Service, government ¹⁸⁸
Customer charge	\$14.65	\$18.47
Energy charge for the first 1,000 kWh	12.14 ¢/kWh	16.47 ¢/kWh
Energy charge between 1,001 – 2,500 kWh	12.82 ¢/kWh	17.47 ¢/kWh
Energy charge for energy in excess of 2,500 kWh	13.99 ¢/kWh	18.85 ¢/kWh

Table 123: General service energy prices in Pelly Crossing

	General Service, non-government ¹⁸⁹	General Service, government - municipal ¹⁹⁰	General Service, government – federal & territorial ¹⁹¹
Demand Charge for all kW of billing demand*	\$7.39 / kW	\$7.39 / kW	\$12.31 / kW
Energy charge for the first 2,000 kWh	10.00 ¢/kWh	10.00 ¢/kWh	13.81 ¢/kWh
Energy charge between 2,001 – 15,000 kWh	12.88 ¢/kWh	12.88 ¢/kWh	15.00 ¢/kWh
Energy charge between 15,001 – 20,000 kWh	15.68 ¢/kWh	15.68 ¢/kWh	20.00 ¢/kWh
Energy charge for	12.86 ¢/kWh	12.86 ¢/kWh	12.86 ¢/kWh

**energy in excess of
20,000 kWh**

*where the billing demand may be estimated or measured and will be the greater of the following: A) The highest metered demand during the billing period. B) The highest metered demand during the 12 months ending with the current billing month, excluding the months April through September. C) The estimated demand. D) 5 kilowatts.

Table 124: Pelly Crossing 2015 residential fuel prices¹⁹²

Month	Furnace Oil (¢/L)	Arctic Stove Oil (¢/L)	Propane (\$/500 gallon tank)
December	103.5	105.6	No Data
November	105.6	109.2	No Data
October	105.6	109.7	No Data
September	105.6	107.8	No Data
August	110.9	110.9	No Data
July	110.9	111.7	No Data
June	110.9	112.5	No Data
May	110.9	112.3	No Data
April	110.9	114.0	No Data
March	110.9	114.7	No Data
February	110.9	112.0	No Data
January	No Data	110.6	No Data

Infrastructure

Table 125: Pelly Crossing infrastructure profile

List of Relevant Infrastructure	
Transportation Infrastructure	Tourism infrastructure
Highway access via Klondike Highway 3,305 ft. gravel airstrip with limited maintenance	Hotel Restaurant RV park & campground
Communication Infrastructure	Emergency Services
Cell reception: Latitude Wireless High speed internet: NorthwesTel Landline phone service: NorthwesTel	Health Centre (1 nurse on staff) Volunteer Ambulance on call 24 hours Medevac available 24 hours for emergencies Volunteer Fire on call 24 hours RCMP detachment
Business Infrastructure	Housing Infrastructure
Gas Station TD Bank General store	145 Private dwellings 132 Normally occupied dwellings 120 Single detached houses 0 Apartments (5+ storeys) 0 Apartments (<5 storeys)

	5 Movable dwellings 0 Semi-detached houses 0 Row houses 0 Duplexes
Educational Infrastructure	Recreation Infrastructure
Grade school up to grade 12 Yukon College Pelly Crossing Campus	Community Centre Indoor summer swimming pool Indoor skating rink Curling facilities

Economics

Table 126: Pelly Crossing 2015 Spatial Price Index (Whitehorse = 100)

Meat	No Data	Household Operations	No Data
Dairy/eggs	No Data	Health and Personal Care	No Data
Fruit/vegetables	No Data	Gasoline	No Data
Bread/cereal	No Data	Cigarettes	No Data
Other Foods	No Data	Total Survey Items	No Data

Industries

Tourism is an important driver of Pelly Crossings local economic base. Heritage sites such as Fort Selkirk draw in tourists, as well as high quality sport fishing and other outdoor adventures. The First Nation’s development corporation has made investments in tourism and many individuals have invested in their own businesses such as food services, crafting, or river tours.

Minto Mine

The Minto Mine is an active copper, gold, and silver mine owned and operated by the Capstone Mining Corp. The mine first began production in 2007 with 1,800 tonnes per day and an expected mine life of 4 years. The mine now produces 3,850 tonnes per day, and is expected to be active until 2021¹⁹³. The existing camp at Minto Mine is made of several mostly connected buildings capable of housing 192 workers, and includes facilities such as a gym and dining hall. Power is currently supplied to the mining site from a 32 km, 34 kV power line from the Yukon’s main electric grid at Minto Landing. The current Power Purchase Agreement between Yukon Energy Corporation and the

Canadian Geothermal Energy Association
 PO Box 1462 Station M, Calgary, Alberta, T2P 2L6, Canada
 info@cangea.ca - www.cangea.ca



Minto Mine allows for a total capacity of 4400 kVA with a total annual consumption limitation of 32.5 GWh¹⁹⁴. The mine was initially powered by diesel generators, and now uses these units during electrical service disruptions.

Table 127: Minto Mine 2014 Key Operational Facts¹⁹⁵

Ownership	100%
Primary product mined	Copper
By-products	Gold, silver
Grade (Cu%)	1.37
Mine type	Open pit / underground
Life remaining (years)	5
Operating throughput	3,850 tonnes per day
2014 production	18,400 k tonnes
Workforce (including contract employees)	282

Ross River

Overview

Ross River is located 4 hours north east of Whitehorse and less than one hour from Faro along the Robert Campbell Highway. The Ross River Dena Council is included in the Kaska Nation. is situated within the traditional territory of the Ross River Dena Council. The Kaska people make up over 85% of the population, and the Ross River Dena Council is one of 3 Yukon First Nations without a land claims agreement. Located at the confluence of the Ross and Pelly rivers, it was an important trading post in the past. Today Ross River is known for it's beautiful scenery and traditional culture in the arts.



Ross River, source: Google

Demographics

Table 128: Ross River 2011 demographics¹⁹⁶

Classification	Settlement	Percent of population over 15	No Data
Population in 2011	352	Total private dwellings	184
Population in 2006	313	Private dwellings occupied by usual residents	150
2006 to 2011 population change	+12.5%	Land area	20.62 km ²
Median age	No Data	Population density	17.1 / km ²

Geothermal Potential

Table 129: Temperature at depth & technical geothermal potential in Ross River

Depth in m	Temperature	Technical	Technical	Technical
------------	-------------	-----------	-----------	-----------

	in °C	Potential with 5% recovery in MW	Potential with 14% recovery in MW	Potential with 20% recovery in MW
1,500	52	-	-	-
2,500	78	0.21	0.59	0.84
3,500	104	4.71	13.19	18.84
4,500	129	5.43	15.20	21.72

Ross River is part of the main hydro-electric grid and has a temperature profile that enables electricity production through tapping the subsurface resources at a depth of roughly 2,500m.

The evaluation of project costs for Ross River is not 100% accurate. CanGEA has undertaken calculations for binary power plant costs in the past and the results of these calculations are used in this report. The assumptions used for these calculations are not identical to the real local circumstances.

CanGEA's archive states the cost for a 1 MW_e/13 MW_t CHP project set in a Wet Fractured Rock environment in the Canadian North to be roughly \$31 million. A cost table can be found in Table 130. The actual cost for Ross River would likely be higher, as the drilling depth is estimated to be deeper than in the calculatory example (2,100m)

Table 130: Cost table for an exemplary 1 MW_e/13 MW_t CHP project in northern Canada (Wet Fractured Rock environment).

Cost Category	Cost in million \$
Exploration and Drilling	18.0
Well Pumps	1.7
ORC Unit	4.0
Facility	2.6
Construction	0.8
Materials	0.7
Engineering	0.5
Contingency	2.8

Assuming a capacity factor of 0.9, a recovery factor that is able to support the supply of the binary unit, the potential to sell all produced electricity (7,884,000 kWh/a), constant

achievable prices, a project lifetime of 50 years, a Weighted Average Cost of Capital (WACC) of 8%, construction cost payable up front and disregarding annual maintenance cost, the break even price for power production only is approximately \$0.30/kWh. The break-even price can be lowered / the NPV can be increased by adding a cascaded heat system that could be used for additional profit generation.

Due to Ross River's connection to the hydroelectric grid, an economic production of geothermally produced electricity is questionable. Nevertheless, the area can be characterized as a heavy user of electricity and heat as Ross River is located in close proximity to various mining operations. These projects require large amounts of electricity and heat, which could partly be supplied by geothermal energy. Especially medium-temperature geothermal direct use applications could be economically and environmentally beneficial for Ross River and the surrounding area.

In addition to the town, the mining sites that are present in the area could potentially serve as demand centres for geothermal electricity and heat. More information about the mines is portrayed later in this chapter.

It is assumed that the temperature of the geothermal fluid leaving the binary power plant will decrease by about 17 °C from the incoming fluid, as this has been the case for other binary power plants of similar size. The outlet temperature should allow for further cascaded use of the fluid, which may be economically beneficial and is strongly suggested for Ross River. Along with many other northern communities, district heating, horticulture and additional direct-use applications of geothermal energy may be economically viable for Ross River.

Geothermal Greenhouses

Horticultural applications could create value by providing locally grown fruits and vegetables for consumption by the Ross River community. Food is currently 37% more expensive than in Whitehorse, while fresh fruit and vegetables are 42% more expensive than in the territory's capital.

Canadian Geothermal Energy Association
PO Box 1462 Station M, Calgary, Alberta, T2P 2L6, Canada
info@cangea.ca - www.cangea.ca



Geothermal power can be used to not only heat a greenhouse, but also to supply the building with electricity for artificial lighting to assist in the optimal growth of plants. A greenhouse powered by geothermal energy could make a true year-round operation possible in Ross River and support the community with fresh produce at any time of the year.

Only 37.3% of Yukon residents reported fruit and vegetable consumption of 5 or more times per day in 2008.¹⁹⁷ Initially, a design of a greenhouse powered by geothermal energy that could produce spinach all-year round for the population of Ross River was considered. Spinach was chosen for this design as an example of what could be grown since it is a nutrient dense vegetable, with one serving providing nutrients that include 5% of a person's daily iron and 56% of a person's daily recommended vitamin A intake. It is also a versatile vegetable that can be worked into various meals or snacks, as well as eaten raw or frozen to be consumed at a later date.

The greenhouse is designed to provide fresh vegetables all year round to the Ross River community during 7 harvests, since spinach takes about 8 weeks until it can be harvested. To yield one servings of spinach per day, based on the Canada Food Guide, to each resident of Ross River over a three week long period a greenhouse would need to have approximately 1,600 sqft of growing area. This area does neither account for extra space needed to maneuver in the greenhouse nor for space for packaging and storing the produce. As it is assumed that the plants will take up 60% of the total greenhouse area, the final space needed for the operation of the greenhouse is 2667 sqft. A harvest of this size would provide the possibility for each resident of Ross River to consume fresh vegetables at least once per day during three weeks following each harvest. As the yield per square metre and the suggested serving size differ for each fruit and vegetable, the overall size of the greenhouse changes with its produce selection. In order to provide a serving of beets per day for every resident of Ross River the greenhouse would need a floor space of 4,200 sqft. Tomatoes can have a very high yield per square metre. Therefore it is suggested to add floor space to the greenhouse in order be able to supply fresh tomatoes on a regular basis to the residents of Ross River. A growing area of 220 sqft should suffice to produce over 20 servings of tomatoes per resident each year. An overall size of 3,000 sqft (1,800 sqft growing area) is suggested.

Table 131: Estimated vegetable production for 1,800 sqft of growing space – Ross River

Product	Grams per 1,800 sqft	Grams per serving	Total servings per 1,800 sqft
Spinach	267,200	32,5	8,222
Tomato	8,350,000	137	61,852
Beets	375,750	71	5,292

In cold climates, it is of importance to collect as much sunlight as possible while minimizing the negative effect that shadow has on crop growth. A length to width ratio of at least 2:1 is recommended while orienting the structure in an east-west direction. Due to the high latitude of any location within the Yukon the northern side of a greenhouse will not collect direct sunlight. The outer surfaces that are able to utilize the sun’s light and heat will be made of 3-wall polycarbonate as it can withstand high winds and a considerable snow load while offering good insulation values. The surfaces of the greenhouse that will not be in direct contact with the sunlight will be made of an aluminum frame with insulation between the inner and outer walls. This will further minimize heat loss, allowing for a more efficient heat management in the greenhouse. The whole frame of the greenhouse can be made out of aluminum, as it is the dominant material on the market. Aluminum offers multiple advantages over wood or steel, as it is longer lasting and relatively light. Additionally, the inclination on the south facing roof should be chosen in a way that maximizes the natural solar heat gain. For the Ross River Greenhouse, a roof inclination of 45 degrees will be used to allow for this solar heat gain and easy removal of materials that may cover the roof such as snow.

With these design considerations in mind, a preliminary design for the greenhouse can be obtained, allowing for a rough cost estimate to be made. The greenhouse will be a long rectangular prism of 2:1 length to width with a triangular roof. This design coupled with a required floor space of 3,000 sqft produces a greenhouse with the following dimensions.

Table 132: Exemplary greenhouse design – Ross River

Dimension	ft
Length	77

Width	39
Height of north/south wall	10
Height of peak	31

Table 133: Exemplary greenhouse design – surface areas - Ross River

Dimension	ft
South Wall	775
East Wall	995
West Wall	995
North Wall	775
South Roof	2,855
North Roof	2,855
Total	9,249

The east, west and south walls as well as the south facing roof will all be made out of 3-wall polycarbonate as they will be the walls capable of using the sun’s heat and light. The north wall and north facing roof will be made out of aluminum siding/roofing with layers of insulation on the inner walls of the material to reduce heat loss. Prices are averaged prices obtained by selective market research. Real prices in Ross River can differ.

Table 134: Exemplary greenhouse design – material cost - Ross River

Material	Amount (ft²)	Cost (\$/ft²)	Total cost (\$)
Aluminum framing	616	2.5	1,539
Polycarbonate	5,619	1.99	11,183
Insulation	3,630	1.5	5,445
Aluminum roofing	2,855	3.99	11,393
Total			29,560

In order for the greenhouse to be operational during the whole year, it must be able to maintain an inside temperature of minimum 15 °C while the outside temperature is -27 °C. In these conditions, a minimum heat rating of 55kW is required. A 75kW diesel generator on ¾ load would require 17.4 litres of diesel per hour to provide sufficient heating in these harsh conditions. This equates to 418 litres of diesel fuel per day,

costing roughly \$477 at \$1.14 per litre. As temperatures can drop below the estimated average low, a backup heating system can be installed to avoid frost damage.

It is advisable to build the greenhouse in a location close to the binary power plant to ensure the geothermal fluid flowing from the plant to the greenhouse experiences minimal heat loss during the transport. This location should also be in close proximity to the community to allow for easy access and operation. If there is existing infrastructure near a suitable building site in Ross River, the greenhouse could be attached to a building, which will reduce the initial construction costs of the greenhouse, as well as to minimize its heat loss.

The next steps in the design of the greenhouse are to decide on lighting and piping. The lighting system and the pipes should be laid out evenly in order to maintain a uniform heat distribution within the greenhouse. Depending on the ground area of the greenhouse, two inflow pipes should be used, which transport the water in alternating directions in order to minimize the effect the heat loss along the piping system has on the uniformity of the temperature distribution within the building. The minimum temperature of the greenhouse should not drop below 0°C. In order to minimize heat loss when entering the greenhouse, a heated arctic entry should be considered. When designing the pipe and lighting layout it is important that it is closely linked to the alignment of the crops being grown. Between crop rows, tracks need to be wide enough to ensure effective harvesting and allowing maintenance on the heating and lighting system.

The northern latitude of Ross River results in widely varying daylight periods throughout the year. The longest day of the year averages approximately 18 hours long, and the shortest day of the year is roughly 5 hours long. This variation in daylight hours creates challenges for greenhouse operations in Ross River, and the greenhouses must have an LED lighting system in place to accommodate for these varying amounts of sun. The lighting systems used in the Alaskan Chena Hot Springs greenhouses are designed specifically for each crop in order to be as energy efficient as possible. Similarly, greenhouses constructed in Ross River should be energy conscious with their lighting

system, using LED lighting for their energy efficiency, and to accommodate for fluctuating daylight hours throughout the year.

Due to the low soil temperatures in a northern environment like Ross River, the use of raised planting beds is advisable. Additionally, raised beds can make harvesting the produce easier as the beds are raised to working level.

As plants need water and fertilizer for their growth, choices on irrigation systems and fertilizer selection have to be made. For Ross River a fertigation system would be preferable, which means that a fertilizer water solution is used. This system works on a drip irrigation basis with added root moisture sensors, which ensure an optimal moisture and nutrient level at all times.

Ventilation systems offer effective temperature adjustment with little effort. It is advisable to install an automated system, which regulates the indoor temperature through automated opening and closing of vents.

The temperature after the heating of the greenhouse should be high enough to be used for further cascaded applications such as drying fresh food products, heated storage or other types of public facilities, district heating and the heating of public swimming pools. These applications that could be beneficial to Ross River, in addition to being powered in an affordable and efficient way by geothermal power will be discussed in further detail below.

Drying of Greenhouse products

The drying of food is an application that is can be particularly meaningful to northern communities, since it is a way to preserve fruits and vegetables that are not abundant in these climates for future consumption. Though it is important to note that dried fruits and vegetables cannot replace their fresh versions since there is some nutrient loss caused by dehydration, these products can be used to supplement diets and have a high caloric density with dried fruits and vegetables containing up to five time more calories than their fresh counterparts. A food drying facility in Ross River could use the excess heat

that is available after heating the greenhouse to heat up the drying chamber. A dehumidifier and an air pump can be electrically powered and should be used in wet weather. Good primary drying conditions require a relative humidity between 20% and 50% and an air velocity of approximately 3 m/s. For perfect results a second drying process with higher temperatures and lower air velocity can be added.

Space heating

The dense settlement structure in parts of Ross River makes a district heating system a potentially attractive application for the community. Heat derived from the geothermal fluid flowing out of the power plant could provide a more affordable and environmental way to heat the larger buildings of the town.

Ross River could also be home to geothermally heated community buildings that could be used for community social events and storage, among many other potential uses. A space heated to room temperature could be used in part for animal husbandry, more specifically the raising of chickens for eggs and meat throughout the winter. This could be an important endeavour for a community like Ross River that cannot keep animals all year round outdoors due to its cold climate.

Aquaculture

Different species of fish could be raised for human consumption all year round in Ross River through the use of aquaculture powered and heated by geothermal energy.

Some examples of fish that are native to this region are Arctic grayling, northern pike and lake trout. For this example, an aquaculture system for the farming of rainbow trout, a commonly cultured fish that cannot already be found in Ross River is suggested. Rainbow trout is a good source of protein with an average marketable size fish, between 0.5 to 1.0 kg and a good source of Omega-3 essential acids. Trout will exhibit optimum growth at 17°C, though they can survive between temperatures of 0°C to 27°C. This species of trout will take about 6 to 8 months to reach their optimal market size.

For fish of 500g in size, the tank should be able to maintain a flow through of 5 l/min/m³ and can produce about 50 fish per m³. For a community like Ross River a reasonably large tank could be built and the fish produced could be frozen for later consumption or to be sold to nearby communities. To complete all steps of fish farming in Ross River, hatching and rearing tanks will also need to be constructed. The location of Ross River close to a freshwater source is ideal since this water could be used to fill the tanks in which to grow the trout.

General assumptions can be made about the piping that will be required for the heat exchanger and their location in relation to the tank. For example, steel or FRP (Fibreglass Reinforced Plastic) piping could be used to carry the hot fluid to and from the heat exchanger and PVC piping could be used to circulate the warm fluid through the tank. A method to reduce heat loss due to the cold northern temperatures and evaporation all year round from the tanks would be to cover them with a roof structure similar to that of a greenhouse and heat the space surrounding the tank.

One way to simplify the aquaculture system is to grow vegetation on the surface of the water that will enable some feeding of the trout, as well as to filter the water in the tanks. For example, numerous floating and rooted water plants could be grown on the surface of the water in the fish tanks, like duck weed, water lettuce, water hyacinth, water cress and water parsnip. The plants will reproduce naturally and survive off of nutrients in the water, sunlight and the carbon dioxide produced by the fish. In return, the plants oxygenate the water and could potentially be a source of food for the fish.

Geothermal heated swimming pool

There is already a swimming pool operating in Ross River. However, it only operates seasonally and Ross River residents have expressed their desire for the pool to be opened all year round.

During the summer when the pool is open, it is heated by oil-fired boilers. This heating system also heats the changing rooms, showers and mechanical room at the pool.¹⁹⁸ Swimming pools are normally heated to between 25 and 28 °C. Installing a geothermal

heat exchanger to heat the pool to this temperature would be beneficial for the community as it would provide another way for residents to exercise regularly in the winter months and is a measure to improve the quality of life in general.

Cost of Energy

Table 135: Residential energy prices in Ross River

	Residential Service, non-government ¹⁹⁹	Residential Service, government ²⁰⁰
Customer charge	\$14.65	\$18.47
Energy charge for the first 1,000 kWh	12.14 ¢/kWh	16.47 ¢/kWh
Energy charge between 1,001 – 2,500 kWh	12.82 ¢/kWh	17.47 ¢/kWh
Energy charge for energy in excess of 2,500 kWh	13.99 ¢/kWh	18.85 ¢/kWh

Table 136: General service energy prices in Ross River

	General Service, non-government ²⁰¹	General Service, government - municipal ²⁰²	General Service, government – federal & territorial ²⁰³
Demand Charge for all kW of billing demand*	\$7.39 / kW	\$7.39 / kW	\$12.31 / kW
Energy charge for the first 2,000 kWh	10.00 ¢/kWh	10.00 ¢/kWh	13.81 ¢/kWh
Energy charge between 2,001 – 15,000 kWh	12.88 ¢/kWh	12.88 ¢/kWh	15.00 ¢/kWh
Energy charge between 15,001 – 20,000 kWh	15.68 ¢/kWh	15.68 ¢/kWh	20.00 ¢/kWh
Energy charge for energy in excess of 20,000 kWh	12.86 ¢/kWh	12.86 ¢/kWh	12.86 ¢/kWh

*where the billing demand may be estimated or measured and will be the greater of the following: A) The highest metered demand during the billing period. B) The highest metered demand during the 12 months ending with the current billing month, excluding the months April through September. C) The estimated demand. D) 5 kilowatts.

Table 137: Ross River 2015 residential fuel prices²⁰⁴

Month	Furnace Oil (¢/L)	Arctic Stove Oil (¢/L)	Propane (\$/500 gallon tank)
December	102.9	106.1	71.3

November	105.0	108.2	74.3
October	105.0	108.2	82.4
September	105.0	108.2	81.0
August	110.9	114.0	79.3
July	110.9	114.0	79.3
June	110.9	114.0	82.5
May	110.3	113.4	85.6
April	110.3	113.4	84.9
March	110.3	113.4	84.5
February	110.3	113.4	84.5
January	115.0	118.2	87.7

Infrastructure

Table 138: Ross River infrastructure profile

List of Relevant Infrastructure	
Transportation Infrastructure	Tourism infrastructure
Highway access via Robert Campbell Highway Gravel airstrip maintained year-round	Hotel Restaurant RV park & campground
Communication Infrastructure	Emergency Services
Cell reception: Latitude Wireless High speed internet: NorthwesTel Landline phone service: NorthwesTel	Health Centre (2 nurses on staff) Volunteer Ambulance in Faro (74 km away) Medevac available 24 hours for emergencies Volunteer Fire on call 24 hours RCMP detachment
Business Infrastructure	Housing Infrastructure
TD Bank Grocery store Gas station	184 Private dwellings 150 Normally occupied dwellings 0 Single detached houses 0 Apartments (5+ storeys) 0 Apartments (<5 storeys) 0 Movable dwellings 0 Semi-detached houses 0 Row houses 0 Duplexes
Educational Infrastructure	Recreation Infrastructure
Grade school up to grade 10 Yukon College Ross River Campus	Recreation centre Hockey arena Multi-purpose areas

Economics

Table 139: Ross River 2015 Spatial Price Index (Whitehorse = 100)²⁰⁵

Meat	123.1	Household Operations	140.0
Dairy/eggs	105.3	Health and Personal Care	133.6
Fruit/vegetables	142.0	Gasoline	105.7
Bread/cereal	127.6	Cigarettes	110.1
Other Foods	137.0	Total Survey Items	120.0

Industries

The economic base of Ross River includes government services in the federal, territorial, First Nation and municipal governments. Private industries primarily include tourism, and tourism related services.

Mactung Mine

The Mactung project is located 250 km northeast of Ross River and can be accessed by road. It is owned and operated by the North American Tungsten Corporation. It is run as an underground tungsten mining project. The lifetime of the underground mining facility is calculated as 11.2 years. This could be prolonged by 17 years of open pit mining. The property lies within the traditional territory of the Na-Cho Nyak Dun First Nation and the Kaska Dena First Nation. Access to the electrical grid is not available. The power generation is based on diesel combustion.

Table 140: Mactung mine based on technical report²⁰⁶

Ownership	100% North American Tungsten Corporation Ltd.
Resource	33 million tonnes with 0.88% WO ₃ (indicated)
Primary Metals	Tungsten
Mine Type	Open pit + underground
Mine Life	11 years (underground) + 17 years (open pit)
Employees	180 (peak production), 250 (peak construction)
Location	250 km northwest of Ross River
Infrastructure	Good road access
Power	Diesel generator (8.5 MW)
Status	Operating

Wolverine Mine

The Wolverine mining project is located 180 km south of Ross River and is owned by the Yukon Zinc Corporation. The underground mine host's exploitable deposits including zinc, silver, gold, copper and lead. The site encompasses 107 square kilometres and is accessible by road. Infrastructural features were constructed from 2009 to 2010 and operations started in 2011. Since January 2015 the mine is temporarily closed due to unfavourable market conditions. Recently some of the mineshafts were observed to be flooded with water. Future development is currently being discussed.

Table 141: Wolverine mine– June 2014²⁰⁷

Ownership	100% Yukon Zinc Corporation
Primary Metals	Zinc, copper, silver, lead, gold
Mine Type	Underground
Location	180 km south of Ross River
Infrastructure	Good road access,
Power	11km from Yukon power grid
Status	Operations suspended

Selwyn Mine

The Selwyn project is proposed to become a zinc and lead mine, located 165km east of Ross River. The road-accessible site is owned by Selwyn Chihong Mining Ltd. The lifetime of the project is estimated to be at least 10 years, employing 750 people during operation and 1,500 during the construction period. The processing capacity is forecasted to be 35,000 tonnes per day using conventional milling and flotation. This leads to an expected daily yield of 2,500 tonnes of zinc concentrate and 600 tonnes of lead concentrate, which would be transported to Stewart, BC by truckload. A pre-feasibility study was supposed to be completed in 2015, but was not available in January 2016. Production is scheduled to start in 2022.

Table 142: Selwyn mine data²⁰⁸

Ownership	100% Selwyn Chihong Mining Ltd.
Capacity	Processing 35,000 tonnes of ore per day
Primary Metals	Zinc, lead
Mine Type	Open pit
Mine Life	10+ years
Employees	1,500 (peak production), 750 (peak construction)

Canadian Geothermal Energy Association
PO Box 1462 Station M, Calgary, Alberta, T2P 2L6, Canada
info@cangea.ca - www.cangea.ca



Location	165km east of Ross River
Infrastructure	road access
Status	Advanced Exploration

Tagish

Tagish is located 1 hour south east of Whitehorse and 30 minutes away from Carcross on Tagish Road. Tagish Road is part of the Southern Lakes Loop; a popular circuit for tourists south of Whitehorse that also includes a short stretch of the Alaska and Klondike highways. Tagish is home to the self governing Carcross/Tagish First Nation, whose administrative centre is located in the nearby settlement of Carcross. Tagish is a popular tourist location during the summer months, given it's natural beauty and close proximity to Whitehorse.



Tagish, source: Google

Demographics

Table 143: Tagish 2011 demographics²⁰⁹

Classification	Settlement	Percent of population over 15	89.3
Population in 2011	391	Total private dwellings	432
Population in 2006	222	Private dwellings occupied by usual residents	206
2006 to 2011 population change	+76.1%	Land area	45.59 km ²
Median age	53.6	Population density	8.6 / km ²

Geothermal Potential

Table 144: Geothermal potential in Tagish

Thermal Gradient (mK/m)	Heat Energy at 3.5km depth (E¹⁸ Joules)	Heat Energy at 6.5km depth (E¹⁸ Joules)
TBD	TBD	TBD

Table 145: Temperature at depth & technical geothermal potential in Tagish

Depth in m	Temperature in °C	Technical Potential with 5% recovery in MW	Technical Potential with 14% recovery in MW	Technical Potential with 20% recovery in MW
1,500	53	-	-	-
2,500	88	4.17	11.68	16.68
3,500	109	5.10	14.28	20.40
4,500	129	5.71	15.99	22.84

Tagish is a part of the main hydroelectric grid and has a well developed temperature profile.

The evaluation of project costs for Tagish is not 100% accurate. CanGEA has undertaken calculations for binary power plant costs in the past and the results of these calculations are used in this report. The assumptions used for these calculations are not identical to the real local circumstances.

CanGEA’s archive states the cost for a 1 MW_e/13 MW_t CHP project set in a Hot Sedimentary Aquifer environment in the Canadian North with a drilling depth of 3,500m to be roughly \$28 million. A cost table can be found in Table 146. The actual cost for Tagish would be lower, as the drilling depth would stay below 2,500m.

Table 146: Cost table for an exemplary 1 MW_e/13 MW_t CHP project in northern Canada (HSA environment).

Cost Category	Cost in million \$
Exploration and Drilling	15.6
Well Pumps	1.7
ORC Unit	4.0
Facility	2.6
Construction	0.8
Materials	0.7
Engineering	0.4
Contingency	2.6

Assuming a capacity factor of 0.9, the potential to sell all produced electricity (7,884,000 kWh/a), constant achievable prices, a project lifetime of 50 years, a Weighted Average Cost of Capital (WACC) of 8%, construction cost payable up front and disregarding annual maintenance cost, the break even price for power production only is approximately \$0.27/kWh. The break-even price for Tagish would be slightly lower, since the drilling cost would be not as high as in CanGEA's archived example. If 2,500m drilling depth with an assumed cost of \$11.1 million are used, the break-even price drops to roughly \$0.23/kWh. The break-even price can be lowered / the NPV can be increased by adding a cascaded heat system that could be used for additional profit generation.

It is assumed that the temperature of the geothermal fluid leaving the binary power plant will decrease by about 17 °C from the incoming fluid, as this has been the case for other binary power plants of similar size. The outlet temperature should allow for further cascaded use of the fluid, which may be economically beneficial and is strongly suggested for Tagish. Along with many other northern communities, district heating, horticulture and additional direct-use applications of geothermal energy may be economically viable for Tagish.

Geothermal Greenhouses

Horticultural applications could create value by providing locally grown fruits and vegetables for consumption by the Ross River community. Geothermal power can be used to not only heat a greenhouse, but also to supply the building with electricity for artificial lighting to assist in the optimal growth of plants. A greenhouse powered by geothermal energy could make a true year-round operation possible in Tagish and support the community with fresh produce at any time of the year.

Only 37.3% of Yukon residents reported fruit and vegetable consumption of 5 or more times per day in 2008.²¹⁰ Initially, a design of a greenhouse powered by geothermal energy that could produce spinach all-year round for the population of Tagish was considered. Spinach was chosen for this design as an example of what could be grown since it is a nutrient dense vegetable, with one serving providing nutrients that include 5% of a person's daily iron and 56% of a person's daily recommended vitamin A intake.

It is also a versatile vegetable that can be worked into various meals or snacks, as well as eaten raw or frozen to be consumed at a later date.

The greenhouse is designed to provide fresh vegetables all year round to the Tagish community during 7 harvests, since spinach takes about 8 weeks until it can be harvested. To yield one servings of Spinach per day, based on the Canada Food Guide, to each resident of Tagish over a two week long period after each harvest a greenhouse would need to have approximately 1,200 sqft of growing area. This area does neither account for extra space needed to maneuver in the greenhouse nor for space for packaging and storing the produce. As it is assumed that the plants will take up 60% of the total greenhouse area, the final space needed for the operation of the greenhouse is 2,000 sqft. A harvest of this size would provide the possibility for each resident of Tagish to consume fresh vegetables at least once per day during three weeks following each harvest. As the yield per square metre and the suggested serving size differ for each fruit and vegetable, the overall size of the greenhouse changes with its produce selection. In order to provide a serving of beets per day for every resident of Tagish the greenhouse would need a floor space of 2,000 sqft. Tomatoes can have a very high yield per square metre. Therefore it is suggested to add floor space to the greenhouse in order be able to supply fresh tomatoes on a regular basis to the residents of Tagish. A growing area of 250 sqft should suffice to produce over 20 servings of tomatoes per resident each year. An overall size of 2,400 sqft (1,440 sqft growing area) is suggested.

Table 147: Estimated vegetable production for 2,400 sqft of growing space - Tagish

Product	Grams per 2,400 sqft	Grams per serving	Total servings per 2,400 sqft
Spinach	214,400	32,5	6,597
Tomato	6,700,000	137	49,630
Beets	301,500	71	4,246

In cold climates, it is of importance to collect as much sunlight as possible while minimizing the negative effect that shadow has on crop growth. A length to width ratio of at least 2:1 is recommended while orienting the structure in an east-west direction. Due to the high latitude of any location within the Yukon the northern side of a greenhouse will not collect direct sunlight. The outer surfaces that are able to utilize the sun's light

and heat will be made of 3-wall polycarbonate as it can withstand high winds and a considerable snow load while offering good insulation values. The surfaces of the greenhouse that will not be in direct contact with the sunlight will be made of an aluminum frame with insulation between the inner and outer walls. This will further minimize heat loss, allowing for a more efficient heat management in the greenhouse. The whole frame of the greenhouse can be made out of aluminum, as it is the dominant material on the market. Aluminum offers multiple advantages over wood or steel, as it is longer lasting and relatively light. Additionally, the inclination on the south facing roof should be chosen in a way that maximizes the natural solar heat gain. For the Tagish Greenhouse, a roof inclination of 45 degrees will be used to allow for this solar heat gain and easy removal of materials that may cover the roof such as snow.

With these design considerations in mind, a preliminary design for the greenhouse can be obtained, allowing for a rough cost estimate to be made. The greenhouse will be a long rectangular prism of 2:1 length to width with a triangular roof. This design coupled with a required floor space of 2,400 sqft produces a greenhouse with the following dimensions.

Table 148: Exemplary greenhouse design – Tagish

Dimension	ft
Length	69
Width	34
Height of north/south wall	10
Height of peak	28

Table 149: Exemplary greenhouse design – surface areas - Tagish

Dimension	ft
South Wall	693
East Wall	832
West Wall	832
North Wall	693
South Roof	2,284
North Roof	2,284
Total	7,619

The east, west and south walls as well as the south facing roof will all be made out of 3-wall polycarbonate as they will be the walls capable of using the sun’s heat and light. The north wall and north facing roof will be made out of aluminum siding/roofing with layers of insulation on the inner walls of the material to reduce heat loss. Prices are averaged prices obtained by selective market research. Real prices in Tagish can differ.

Table 150: Exemplary greenhouse design – material cost - Tagish

Material	Amount (ft²)	Cost (\$/ft²)	Total cost (\$)
Aluminum framing	501	2.5	1,253
Polycarbonate	4,642	1.99	9,237
Insulation	2,977	1.5	4,466
Aluminum roofing	2,284	3.99	9,114
Total			24,070

In order for the greenhouse to be operational during the whole year, it must be able to maintain an inside temperature of minimum 15 °C while the outside temperature is -20 °C, which is the estimated average low for the coldest month in Tagish. In these conditions, a minimum heat rating of 38 kW is required. This will be provided from the power plant outlet stream. A 40 kW diesel generator running on full load would require 15.1 litres of diesel per hour to provide sufficient heating in these harsh conditions. This equates to 362 litres of diesel fuel per day, costing roughly \$413 at \$1.14 per litre. As temperatures can drop below the estimated average low, a backup heating system can be installed to avoid frost damage.

It is advisable to build the greenhouse in a location close to the hypothetical binary power plant to ensure the geothermal fluid flowing from the plant to the greenhouse experiences minimal heat loss during the transport. This location should also be in close proximity to the community to allow for easy access and operation. If there is existing infrastructure near a suitable building site in Tagish, the greenhouse could be attached to a building, which will reduce the initial construction costs of the greenhouse, as well as to minimize its heat loss.

Canadian Geothermal Energy Association
PO Box 1462 Station M, Calgary, Alberta, T2P 2L6, Canada
info@cangea.ca - www.cangea.ca



The next steps in the design of the greenhouse are to decide on lighting and piping. The lighting system and the pipes should be laid out evenly in order to maintain a uniform heat distribution within the greenhouse. Depending on the ground area of the greenhouse, two inflow pipes should be used, which transport the water in alternating directions in order to minimize the effect the heat loss along the piping system has on the uniformity of the temperature distribution within the building. The minimum temperature of the greenhouse should not drop below 0°C. In order to minimize heat loss when entering the greenhouse, a heated arctic entry should be considered. When designing the pipe and lighting layout it is important that it is closely linked to the alignment of the crops being grown. Between crop rows, tracks need to be wide enough to ensure effective harvesting and allowing maintenance on the heating and lighting system.

The northern latitude of Tagish results in widely varying daylight periods throughout the year. The longest day of the year averages approximately 18 hours long, and the shortest day of the year is roughly 5 hours long. This variation in daylight hours creates challenges for greenhouse operations in Tagish, and the greenhouses must have an LED lighting system in place to accommodate for these varying amounts of sun. The lighting systems used in the Alaskan Chena Hot Springs greenhouses are designed specifically for each crop in order to be as energy efficient as possible. Similarly, greenhouses constructed in Tagish should be energy conscious with their lighting system, using LED lighting for their energy efficiency, and to accommodate for fluctuating daylight hours throughout the year.

Due to the low soil temperatures in a northern environment like Tagish, the use of raised planting beds is advisable. Additionally, raised beds can make harvesting the produce easier as the beds are raised to working level.

As plants need water and fertilizer for their growth, choices on irrigation systems and fertilizer selection have to be made. For Tagish a fertigation system would be preferable, which means that a fertilizer water solution is used. This system works on a drip irrigation basis with added root moisture sensors, which ensure an optimal moisture and nutrient level at all times.

Canadian Geothermal Energy Association
PO Box 1462 Station M, Calgary, Alberta, T2P 2L6, Canada
info@cangea.ca - www.cangea.ca



Ventilation systems offer effective temperature adjustment with little effort. It is advisable to install an automated system, which regulates the indoor temperature through automated opening and closing of vents.

The remaining temperature after the greenhouse heating can possibly be used for further cascaded applications such as drying fresh food products, heated storage or other types of public facilities, district heating and the heating of public swimming pools. These applications that could be beneficial to Tagish, in addition to being powered in an affordable and efficient way by geothermal power will be discussed in further detail below.

Drying of Greenhouse products

The drying of food is an application that is can be particularly meaningful to northern communities, since it is a way to preserve fruits and vegetables that are not abundant in these climates for future consumption. Though it is important to note that dried fruits and vegetables cannot replace their fresh versions since there is some nutrient loss caused by dehydration, these products can be used to supplement diets and have a high caloric density with dried fruits and vegetables containing up to five time more calories than their fresh counterparts. A food drying facility in Tagish could use the excess heat that is available after heating the greenhouse to heat up the drying chamber (if the temperature is high enough). A de-humidifier and an air pump can be electrically powered and should be used in wet weather. Good primary drying conditions require a relative humidity between 20% and 50% and an air velocity of approximately 3 m/s. For perfect results a second drying process with higher temperatures and lower air velocity can be added.

Space heating

Due to the large populated area, district heating applications do not seem to offer an economical advantage. Geothermal applications for Tagish could include the heating of community focused buildings, though. As Tagish receives a large amount of summer residents annually, the need for sufficiently heated room for communal activities is big. A space heated to room temperature could be used in part for animal husbandry, more

specifically the raising of chickens for eggs and meat throughout the winter. This could be an important endeavour for a community like Tagish that cannot keep animals all year round outdoors due to its cold climate.

Aquaculture

Different species of fish could be raised for human consumption all year round in Tagish through the use of aquaculture powered and heated by geothermal energy.

Some examples of fish that are native to this region are Arctic grayling, northern pike and lake trout. For this example, an aquaculture system for the farming of rainbow trout, a commonly cultured fish that cannot already be found in Tagish is suggested. Rainbow trout is a good source of protein with an average marketable size fish, between 0.5 to 1.0 kg and a good source of Omega-3 essential acids. Trout will exhibit optimum growth at 17°C, though they can survive between temperatures of 0°C to 27°C. This species of trout will take about 6 to 8 months to reach their optimal market size.

For fish of 500g in size, the tank should be able to maintain a flow through of 5 l/min/m³ and can produce about 50 fish per m³. For a community like Tagish a reasonably large tank could be built and the fish produced could be frozen for later consumption or to be sold to nearby communities. To complete all steps of fish farming in Tagish, hatching and rearing tanks will also need to be constructed. The location of Tagish close to a freshwater source is ideal since this water could be used to fill the tanks in which to grow the trout.

General assumptions can be made about the piping that will be required for the heat exchanger and their location in relation to the tank. For example, steel or FRP (Fibreglass Reinforced Plastic) piping could be used to carry the hot fluid to and from the heat exchanger and PVC piping could be used to circulate the warm fluid through the tank. A method to reduce heat loss due to the cold northern temperatures and evaporation all year round from the tanks would be to cover them with a roof structure similar to that of a greenhouse and heat the space surrounding the tank.

One way to simplify the aquaculture system is to grow vegetation on the surface of the water that will enable some feeding of the trout, as well as to filter the water in the tanks. For example, numerous floating and rooted water plants could be grown on the surface of the water in the fish tanks, like duck weed, water lettuce, water hyacinth, water cress and water parsnip. The plants will reproduce naturally and survive off of nutrients in the water, sunlight and the carbon dioxide produced by the fish. In return, the plants oxygenate the water and could potentially be a source of food for the fish.

Cost of Energy

Table 151: Residential energy prices in Tagish

	Residential Service, non-government ²¹¹	Residential Service, government ²¹²
Customer charge	\$14.65	\$18.47
Energy charge for the first 1,000 kWh	12.14 ¢/kWh	16.47 ¢/kWh
Energy charge between 1,001 – 2,500 kWh	12.82 ¢/kWh	17.47 ¢/kWh
Energy charge for energy in excess of 2,500 kWh	13.99 ¢/kWh	18.85 ¢/kWh

Table 152: General service energy prices in Tagish

	General Service, non-government ²¹³	General Service, government - municipal ²¹⁴	General Service, government – federal & territorial ²¹⁵
Demand Charge for all kW of billing demand*	\$7.39 / kW	\$7.39 / kW	\$12.31 / kW
Energy charge for the first 2,000 kWh	10.00 ¢/kWh	10.00 ¢/kWh	13.81 ¢/kWh
Energy charge between 2,001 – 15,000 kWh	12.88 ¢/kWh	12.88 ¢/kWh	15.00 ¢/kWh
Energy charge between 15,001 – 20,000 kWh	15.68 ¢/kWh	15.68 ¢/kWh	20.00 ¢/kWh
Energy charge for energy in excess of 20,000 kWh	12.86 ¢/kWh	12.86 ¢/kWh	12.86 ¢/kWh

*where the billing demand may be estimated or measured and will be the greater of the following: A) The highest metered demand during the billing period. B) The highest metered demand during the 12 months ending with the current billing month, excluding the months April through September. C) The estimated demand. D) 5 kilowatts.

Table 153: Tagish 2015 residential fuel prices²¹⁶

Month	Furnace Oil (¢/L)	Arctic Stove Oil (¢/L)	Propane (\$/500 gallon tank)
December	100.9	109.6	No Data
November	103.0	112.0	No Data
October	103.0	113.2	No Data
September	103.0	112.9	No Data
August	108.3	114.2	No Data
July	108.3	114.7	No Data
June	108.3	115.3	No Data
May	108.3	117.2	No Data
April	108.3	115.5	No Data
March	108.3	119.3	No Data
February	108.3	113.6	No Data
January	No Data	124.4	No Data

Infrastructure

Table 154: Tagish infrastructure profile

List of Relevant Infrastructure	
Transportation Infrastructure	Tourism infrastructure
Highway access via Tagish Road	Hotel/cabins
Air service via nearby Whitehorse	Restaurant
	RV park & campground
Communication Infrastructure	Emergency Services
Cell reception: Latitude Wireless	Health Centre (2 nurses on staff)
High speed internet: NorthwesTel	Volunteer Ambulance on call 24 hours
Landline phone service: NorthwesTel	Medevac available 24 hours for emergencies
	Volunteer Fire on call 24 hours
	RCMP detachment in Carcross
Business Infrastructure	Housing Infrastructure
Post office	432 Private dwellings
Gas station	206 Normally occupied dwellings
General store	205 Single detached houses
	0 Apartments (5+ storeys)
	0 Apartments (<5 storeys)
	5 Movable dwellings
	0 Semi-detached houses
	0 Row houses
	0 Duplexes
Educational Infrastructure	Recreation Infrastructure
Grade school located in Carcross	Recreation complex
Community library in Tagish Community Centre	Community centre
	Library

Economics

Table 155: Tagish 2015 Spatial Price Index (Whitehorse = 100)

Meat	No Data	Household Operations	No Data
Dairy/eggs	No Data	Health and Personal Care	No Data
Fruit/vegetables	No Data	Gasoline	No Data
Bread/cereal	No Data	Cigarettes	No Data
Other Foods	No Data	Total Survey Items	No Data

Industries

The economic base of Tagish includes small local businesses, private contractors, home businesses, trades and tourism related work. Close proximity to Whitehorse means that the benefits of the big city are accessible in just over a 1-hour commute. Tagish experiences a large swing in visitors, being notably high in the summer months.

Teslin

Teslin is located 2 hours south east of Whitehorse and 3 hours west of Watson along the Alaska Highway. Teslin is located in the traditional territory of the self governing Teslin Tlingit First Nation. Approximately two-thirds of the population of Teslin are from the Teslin Tlingit Council. Teslin is the gateway to the Southern Lakes region of the Yukon, which along with being on the Alaska Highway makes it a popular tourist destination for the summer months.



Teslin, source: Google

Demographics

Table 156: Teslin 2011 demographics²¹⁷

Classification	Village	Percent of population over 15	76.2
Population in 2011	122	Total private dwellings	72
Population in 2006	141	Private dwellings occupied by usual residents	50
2006 to 2011 population change	-13.5%	Land area	1.92 km ²
Median age	31.8	Population density	63.6 / km ²

Geothermal Potential

Table 157: Temperature at depth & technical geothermal potential in Teslin

Depth in m	Temperature in °C	Technical Potential with 5% recovery in MW	Technical Potential with 14% recovery in MW	Technical Potential with 20% recovery in MW
1,500	65	-	-	-
2,500	109	5.24	14.67	20.96
3,500	152	6.42	17.98	25.68

4,500	178	7.21	20.19	28.84
-------	-----	------	-------	-------

Teslin is part of the hydroelectric grid and features excellent geothermal potential. The community layout makes it possible to sponsor multiple direct use applications and make them accessible to a large part of Teslin’s population. Limiting factor for economic viability is the small population of Teslin, which leads to low electricity/heating demand.

A 1.5 MW diesel facility was installed to power Teslin when the hydroelectric grid cannot supply the required electricity to the village, e.g. during a power outage. This diesel back-up facility is owned by the Yukon Electrical Company Ltd.²¹⁸

The evaluation of project costs for Teslin is not 100% accurate. CanGEA has undertaken calculations for binary power plant costs in the past and the results of these calculations are used in this report. The assumptions used for these calculations are not identical to the real local circumstances.

CanGEA’s archive states the cost for a 1 MW_e/13 MW_t CHP project set in a Hot Sedimentary Aquifer environment in the Canadian North with a drilling depth of 3,500m to be roughly \$28 million. A cost table can be found in Table 158. The actual cost for Teslin would be considerably lower, as the drilling depth would stay below 2,500m.

Table 158: Cost table for an exemplary 1 MW_e/13 MW_t CHP project in northern Canada (HSA environment).

Cost Category	Cost in million \$
Exploration and Drilling	15.6
Well Pumps	1.7
ORC Unit	4.0
Facility	2.6
Construction	0.8
Materials	0.7
Engineering	0.4
Contingency	2.6

Assuming a capacity factor of 0.9, the potential to sell all produced electricity (7,884,000 kWh/a), constant achievable prices, a project lifetime of 50 years, a Weighted Average

Cost of Capital (WACC) of 8%, construction cost payable up front and disregarding annual maintenance cost, the break even price for power production only is approximately \$0.27/kWh. The break-even price for Teslin would be slightly lower, since the drilling cost would be not as high as in CanGEA's archived example. If 2,500m drilling depth with an assumed cost of \$11.1 million are used, the break-even price drops to roughly \$0.23/kWh. The break-even price can be lowered / the NPV can be increased by adding a cascaded heat system that could be used for additional profit generation.

In the Teslin Community Development Plan, the dependency on fossil fuels for heating purposes is discussed as a major concern to the community. Geothermal heating could be a possible solution to this problem as suitable temperatures are reached at a very reasonable depth. Large heat demand would come from the communal centre and the proposed swimming pool, which could possibly operated on a year round basis while lowering the yearly operations costs significantly.

As already discussed in this report, horticultural application of geothermal energy can ensure that the local price level for fruit and vegetables decreases as the result of readily available local products. In Teslin, the price level for fruit and vegetables is roughly 18% higher than in Whitehorse.

It is assumed that the temperature of the geothermal fluid leaving the binary power plant will decrease by about 17 °C from the incoming fluid, as this has been the case for other binary power plants of similar size. The outlet temperature would allow further cascaded use, which may be economically beneficial and is strongly suggested for Teslin

Geothermal Greenhouses

Horticultural applications could create value by providing locally grown fruits and vegetables for consumption by the Teslin community. Geothermal power can be used to not only heat a greenhouse, but also to supply the building with electricity for artificial lighting to assist in the optimal growth of plants. A greenhouse powered by geothermal energy could make a true year-round operation possible in Teslin and support the community with fresh produce at any time of the year.

Only 37.3% of Yukon residents reported fruit and vegetable consumption of 5 or more times per day in 2008.²¹⁹ Initially, a design of a greenhouse powered by geothermal energy that could produce spinach all-year round for the population of Teslin was considered. Spinach was chosen for this design as an example of what could be grown since it is a nutrient dense vegetable, with one serving providing nutrients that include 5% of a person’s daily iron and 56% of a person’s daily recommended vitamin A intake. It is also a versatile vegetable that can be worked into various meals or snacks, as well as eaten raw or frozen to be consumed at a later date.

The greenhouse is designed to provide fresh vegetables all year round to the Teslin community during 7 harvests, since spinach takes about 8 weeks until it can be harvested. To yield one servings of spinach per day, based on the Canada Food Guide, to each resident of Teslin over each day of the year a greenhouse would need to have approximately 1,500 sqft of growing area. This area does neither account for extra space needed to maneuver in the greenhouse nor for space for packaging and storing the produce. As it is assumed that the plants will take up 60% of the total greenhouse area, the final space needed for the operation of the greenhouse is 2,500 sqft. A harvest of this size would provide the possibility for each resident of Tagish to consume fresh vegetables once per day during every week of the year. As the yield per square metre and the suggested serving size differ for each fruit and vegetable, the overall size of the greenhouse changes with its produce selection. In order to provide a serving of beets per day for every resident of Tagish the greenhouse would need a floor space of 3,875 sqft. Tomatoes can have a very high yield per square metre. Therefore it is suggested to add floor space to the greenhouse in order be able to supply fresh tomatoes on a regular basis to the residents of Tagish. A growing area of 220 sqft should suffice to produce over 20 servings of tomatoes per resident each year. An overall size of 2,900 sqft (1,740 sqft growing area) is suggested.

Table 159: Estimated vegetable production for 1,740 sqft of growing space - Teslin

Product	Grams per 1,740 sqft	Grams per serving	Total servings per 1,740 sqft
Spinach	259,200	32,5	7,975
Tomato	8,100,000	137	60,000

Beets	364,500	71	5,134
-------	---------	----	-------

In cold climates, it is of importance to collect as much sunlight as possible while minimizing the negative effect that shadow has on crop growth. A length to width ratio of at least 2:1 is recommended while orienting the structure in an east-west direction. Due to the high latitude of any location within the Yukon the northern side of a greenhouse will not collect direct sunlight. The outer surfaces that are able to utilize the sun's light and heat will be made of 3-wall polycarbonate as it can withstand high winds and a considerable snow load while offering good insulation values. The surfaces of the greenhouse that will not be in direct contact with the sunlight will be made of an aluminum frame with insulation between the inner and outer walls. This will further minimize heat loss, allowing for a more efficient heat management in the greenhouse. The whole frame of the greenhouse can be made out of aluminum, as it is the dominant material on the market. Aluminum offers multiple advantages over wood or steel, as it is longer lasting and relatively light. Additionally, the inclination on the south facing roof should be chosen in a way that maximizes the natural solar heat gain. For the Teslin Greenhouse, a roof inclination of 45 degrees will be used to allow for this solar heat gain and easy removal of materials that may cover the roof such as snow.

With these design considerations in mind, a preliminary design for the greenhouse can be obtained, allowing for a rough cost estimate to be made. The greenhouse will be a long rectangular prism of 2:1 length to width with a triangular roof. This design coupled with a required floor space of 2,900 sqft produces a greenhouse with the following dimensions.

Table 160: Exemplary greenhouse design – Teslin

Dimension	ft
Length	76
Width	38
Height of north/south wall	10
Height of peak	31

Table 161: Exemplary greenhouse design – surface areas - Teslin

Dimension	ft
	270

South Wall	762
East Wall	968
West Wall	968
North Wall	762
South Roof	2,760
North Roof	2,760
Total	8,979

The east, west and south walls as well as the south facing roof will all be made out of 3-wall polycarbonate as they will be the walls capable of using the sun's heat and light. The north wall and north facing roof will be made out of aluminum siding/roofing with layers of insulation on the inner walls of the material to reduce heat loss. Prices are averaged prices obtained by selective market research. Real prices in Teslin can differ.

Table 162: Exemplary greenhouse design – material cost - Teslin

Material	Amount (ft²)	Cost (\$/ft²)	Total cost (\$)
Aluminum framing	570	2.5	1,492
Polycarbonate	5,458	1.99	10,861
Insulation	3,522	1.5	5,283
Aluminum roofing	2,760	3.99	11,013
Total			78,527.81

In order for the greenhouse to be operational during the whole year, it must be able to maintain an inside temperature of minimum 15 °C while the outside temperature is -22 °C, which is the estimated average low for the coldest month of the year in Teslin. In these conditions, a minimum heat rating of 47 kW is required. This will be provided from the power plant outlet stream. A 60 kW diesel generator on ¾ load would require 14.4 litres of diesel per hour to provide sufficient heating in these harsh conditions. This equates to 346 litres of diesel fuel per day, costing roughly \$394 at \$1.14 per litre. As temperatures can drop below the estimated average low, a backup heating system can be installed to avoid frost damage.

It is advisable to build the greenhouse in a location close to the binary power plant to ensure the geothermal fluid flowing from the plant to the greenhouse experiences minimal heat loss during the transport. This location should also be in close proximity to

the community to allow for easy access and operation. If there is existing infrastructure near a suitable building site in Teslin, the greenhouse could be attached to a building, which will reduce the initial construction costs of the greenhouse, as well as to minimize its heat loss.

The next steps in the design of the greenhouse are to decide on lighting and piping. The lighting system and the pipes should be laid out evenly in order to maintain a uniform heat distribution within the greenhouse. Depending on the ground area of the greenhouse, two inflow pipes should be used, which transport the water in alternating directions in order to minimize the effect the heat loss along the piping system has on the uniformity of the temperature distribution within the building. The minimum temperature of the greenhouse should not drop below 0°C. In order to minimize heat loss when entering the greenhouse, a heated arctic entry should be considered. When designing the pipe and lighting layout it is important that it is closely linked to the alignment of the crops being grown. Between crop rows, tracks need to be wide enough to ensure effective harvesting and allowing maintenance on the heating and lighting system.

The northern latitude of Teslin results in widely varying daylight periods throughout the year. The longest day of the year averages approximately 18 hours long, and the shortest day of the year is roughly 5 hours long. This variation in daylight hours creates challenges for greenhouse operations in Teslin, and the greenhouses must have an LED lighting system in place to accommodate for these varying amounts of sun. The lighting systems used in the Alaskan Chena Hot Springs greenhouses are designed specifically for each crop in order to be as energy efficient as possible. Similarly, greenhouses constructed in Teslin should be energy conscious with their lighting system, using LED lighting for their energy efficiency, and to accommodate for fluctuating daylight hours throughout the year.

Due to the low soil temperatures in a northern environment like Teslin, the use of raised planting beds is advisable. Additionally, raised beds can make harvesting the produce easier as the beds are raised to working level.

As plants need water and fertilizer for their growth, choices on irrigation systems and fertilizer selection have to be made. For Teslin a fertigation system would be preferable, which means that a fertilizer water solution is used. This system works on a drip irrigation basis with added root moisture sensors, which ensure an optimal moisture and nutrient level at all times.

Ventilation systems offer effective temperature adjustment with little effort. It is advisable to install an automated system, which regulates the indoor temperature through automated opening and closing of vents.

The outlet temperature after the greenhouse heating process could be used for further cascaded applications such as drying fresh food products, heated storage or other types of public facilities, district heating and the heating of public swimming pools. These applications that could be beneficial to Teslin, in addition to being powered in an affordable and efficient way by geothermal power will be discussed in further detail below.

Drying of Greenhouse products

The drying of food is an application that is can be particularly meaningful to northern communities, since it is a way to preserve fruits and vegetables that are not abundant in these climates for future consumption. Though it is important to note that dried fruits and vegetables cannot replace their fresh versions since there is some nutrient loss caused by dehydration, these products can be used to supplement diets and have a high caloric density with dried fruits and vegetables containing up to five time more calories than their fresh counterparts. A food drying facility in Teslin could use the excess heat that is available after heating the greenhouse to heat up the drying chamber. A de-humidifier and an air pump can be electrically powered and should be used in wet weather. Good primary drying conditions require a relative humidity between 20% and 50% and an air velocity of approximately 3 m/s. For perfect results a second drying process with higher temperatures and lower air velocity can be added.

Space heating

Teslin is a small community with a reasonably dense settlement structure. This could make a small district heating system a potentially attractive application for the community. Though not all of the houses in Teslin are in close enough proximity to be connected economically to a district heating system, there are many buildings within the village between the Alaska highway and the lake that could be heated by geothermal energy. These buildings include the health centre, school, George Johnston museum, Teslin Tlingit administrative buildings and the Early Learning and Child Care Center.

Teslin could also be home to geothermally heated community buildings that could be used for community social events and storage, among many other potential uses. A space heated to room temperature could be used in part for animal husbandry, more specifically the raising of chickens for eggs and meat throughout the winter. This could be an important endeavour for a community like Teslin that cannot keep animals all year round outdoors due to its cold climate.

Aquaculture

Different species of fish could be raised for human consumption all year round in Teslin through the use of aquaculture powered and heated by geothermal energy.

Some examples of fish that are native to this region are Arctic grayling, northern pike and lake trout. For this example, an aquaculture system for the farming of rainbow trout, a commonly cultured fish that cannot already be found in Teslin is suggested. Rainbow trout is a good source of protein with an average marketable size fish, between 0.5 to 1.0 kg and a good source of Omega-3 essential acids. Trout will exhibit optimum growth at 17°C, though they can survive between temperatures of 0°C to 27°C. This species of trout will take about 6 to 8 months to reach their optimal market size.

For fish of 500g in size, the tank should be able to maintain a flow through of 5 l/min/m³ and can produce about 50 fish per m³. For a community like Teslin a reasonably large tank could be built and the fish produced could be frozen for later consumption or to be sold to nearby communities. To complete all steps of fish farming in Teslin, hatching and

rearing tanks will also need to be constructed. There is a very large source of fresh water near Teslin, since the village is located close to Teslin lake and Nisutlin Bay. Teslin Lake is 125 km long, 3 km wide and reaches a maximum depth of 213 m. This water source means that the lake could supply the required water to be heated by the geothermal fluid and used in the Trout rearing tanks.

General assumptions can be made about the piping that will be required for the heat exchanger and their location in relation to the tank. For example, steel or FRP (Fibreglass Reinforced Plastic) piping could be used to carry the hot fluid to and from the heat exchanger and PVC piping could be used to circulate the warm fluid through the tank. A method to reduce heat loss due to the cold northern temperatures and evaporation all year round from the tanks would be to cover them with a roof structure similar to that of a greenhouse and heat the space surrounding the tank.

One way to simplify the aquaculture system is to grow vegetation on the surface of the water that will enable some feeding of the trout, as well as to filter the water in the tanks. For example, numerous floating and rooted water plants could be grown on the surface of the water in the fish tanks, like duck weed, water lettuce, water hyacinth, water cress and water parsnip. The plants will reproduce naturally and survive off of nutrients in the water, sunlight and the carbon dioxide produced by the fish. In return, the plants oxygenate the water and could potentially be a source of food for the fish.

Geothermal heated swimming pool

Teslin does not have swimming pool at the moment. However, Teslin residents have expressed their desire for a pool and the community has the potential to heat the pool geothermally. Installing a geothermal heat exchanger to heat the pool to this temperature would be beneficial for the community as it would provide another way for residents to exercise regularly in the winter months and is a measure to improve the quality of life in general.

Cost of Energy

Table 163: Residential energy prices in Teslin

	Residential Service, non-government ²²⁰	Residential Service, government ²²¹
Customer charge	\$14.65	\$18.47
Energy charge for the first 1,000 kWh	12.14 ¢/kWh	16.47 ¢/kWh
Energy charge between 1,001 – 2,500 kWh	12.82 ¢/kWh	17.47 ¢/kWh
Energy charge for energy in excess of 2,500 kWh	13.99 ¢/kWh	18.85 ¢/kWh

Table 164: General service energy prices in Teslin

	General Service, non-government ²²²	General Service, government - municipal ²²³	General Service, government – federal & territorial ²²⁴
Demand Charge for all kW of billing demand*	\$7.39 / kW	\$7.39 / kW	\$12.31 / kW
Energy charge for the first 2,000 kWh	10.00 ¢/kWh	10.00 ¢/kWh	13.81 ¢/kWh
Energy charge between 2,001 – 15,000 kWh	12.88 ¢/kWh	12.88 ¢/kWh	15.00 ¢/kWh
Energy charge between 15,001 – 20,000 kWh	15.68 ¢/kWh	15.68 ¢/kWh	20.00 ¢/kWh
Energy charge for energy in excess of 20,000 kWh	12.86 ¢/kWh	12.86 ¢/kWh	12.86 ¢/kWh

*where the billing demand may be estimated or measured and will be the greater of the following: A) The highest metered demand during the billing period. B) The highest metered demand during the 12 months ending with the current billing month, excluding the months April through September. C) The estimated demand. D) 5 kilowatts.

Table 165: Teslin 2015 residential fuel prices²²⁵

Month	Furnace Oil (¢/L)	Arctic Stove Oil (¢/L)	Propane (\$/500 gallon tank)
December	101.6	104.4	71.3
November	103.7	107.9	74.3
October	103.7	108.1	82.4
September	103.7	106.4	81.0
August	109.0	109.6	79.3
July	109.0	110.4	79.3
June	109.0	111.3	82.5
May	109.0	111.4	85.6

April	109.0	112.0	84.9
March	109.0	112.9	84.5
February	109.0	110.3	84.5
January	113.8	115.4	87.7

Infrastructure

Table 166: Teslin infrastructure profile

List of Relevant Infrastructure	
Transportation Infrastructure	Tourism infrastructure
Highway access via Alaska Highway	Hotel
Gravel airstrip maintained by Yukon Government	Restaurant
	RV park & campground
Communication Infrastructure	Emergency Services
Cell reception: Latitude Wireless	Health Centre (2 nurses on staff)
High speed internet: NorthwesTel	Volunteer Ambulance on call 24 hours
Landline phone service: NorthwesTel	Medevac available 24 hours for emergencies
	Volunteer Fire on call 24 hours
	RCMP detachment
Business Infrastructure	Housing Infrastructure
Post office	72 Private dwellings
Gas station	50 Normally occupied dwellings
General store	40 Single detached houses
TD Bank	0 Apartments (5+ storeys)
Various Contractors	0 Apartments (<5 storeys)
	0 Movable dwellings
	5 Semi-detached houses
	0 Row houses
	0 Duplexes
Educational Infrastructure	Recreation Infrastructure
Grade school up to grade 9	Recreation complex
Yukon College Teslin Campus	Indoor hockey arena
Teslin Tlingit Council Workforce Development	Curling sheet
	Banquet hall

Economics

Table 167: Teslin 2015 Spatial Price Index (Whitehorse = 100)²²⁶

Meat	132.3	Household Operations	121.1
Dairy/eggs	117.1	Health and Personal Care	113.8

Canadian Geothermal Energy Association
PO Box 1462 Station M, Calgary, Alberta, T2P 2L6, Canada
info@cangea.ca - www.cangea.ca



Fruit/vegetables	117.6	Gasoline	105.4
Bread/cereal	119.9	Cigarettes	102.1
Other Foods	119.7	Total Survey Items	113.2

Industries

The economic base of Teslin includes government services in the federal, territorial, First Nation and municipal governments. Private industries primarily include tourism, construction, transportation and the service industry.

Watson Lake

Watson Lake is Yukon’s third largest community and is located at the junction of the Alaska Highway and the Robert Campbell Highway. It is within the traditional territory of the Kaska people, and is home to the Liard First Nation. Liard is one of two Kaska Dena communities in the Yukon and is closely related to the Ross River Dena Council. Watson Lake is the first community encountered after crossing the British Columbia – Yukon border on the Alaska Highway, making it a popular stop for many travellers coming and going in the territory.



Watson Lake, source: Google

Demographics

Table 168: Watson Lake 2011 demographics²²⁷

Classification	Town	Percent of population over 15	82.3%
Population in 2011	802	Total private dwellings	417
Population in 2006	846	Private dwellings occupied by usual residents	350
2006 to 2011 population change	-5.2%	Land area	131.3 km ²
Median age	42.5	Population density	6.11 / km ²

Geothermal Potential

Table 169: Temperature at depth & technical geothermal potential in Watson Lake

Depth in m	Temperature in °C	Technical Potential with 5% recovery	Technical Potential with 14% recovery	Technical Potential with 20% recovery

		in MW	in MW	in MW
1,500	43	-	-	-
2,500	72	-	-	-
3,500	101	4.90	13.72	19.60
4,500	128	5.74	16.07	22.96

Watson Lake is an off-grid community; electricity is generated locally from a 5 MW diesel facility.

A similar sized binary geothermal power plant could potentially provide all electric and district heating needs to the community. This would significantly reduce emissions from power and heat generation, and enable new business ventures, like year round greenhouses, contributing to the local economy and food security of the community. Geothermal binary power plants that operate with an installed capacity of around 5 MW have been in operation in many countries and are a reliable source of electricity for the local municipalities. The economic assessment of small-scale binary power plants is of high importance as the cost per capita can be significant. For Watson Lake a drilling depth of roughly 3,500m is suggested. With a very low recovery factor of only 5%, 4.9 MW of electricity could be produced.

CanGEA's archive states the cost for a 5MW_e/66MW_t CHP project set in a Wet Fractured Rock environment in the Canadian North to be roughly \$50 million. A cost table can be found in Table 170. The actual cost for Watson Lake would likely be slightly higher, as the drilling depth is estimated to be deeper than in the calculatory example (2,100m).

Table 170: Cost table for an exemplary 1 MW_e/13 MW_t CHP project in northern Canada (Wet Fractured Rock environment).

Cost Category	Cost in million \$
Exploration and Drilling	23.8
Well Pumps	3.2
ORC Unit	11.8
Facility	2.6
Construction	0.9
Materials	0.7
Engineering	2.6
Contingency	4.5

Assuming a capacity factor of 0.9, the potential to sell all produced electricity (39,420,000 kWh/a), constant achievable prices, a project lifetime of 50 years, a Weighted Average Cost of Capital (WACC) of 8%, construction cost payable up front and disregarding annual maintenance cost, the break even price for power production only is approximately \$0.10/kWh. The break-even price can be lowered / the NPV can be increased by adding a cascaded heat system that could be used for additional profit generation.

It is assumed that the temperature of the geothermal fluid leaving the binary power plant will decrease by about 17 °C from the incoming fluid, as this has been the case for other binary power plants of similar size. An outlet geothermal fluid of 84 °C allows for further cascaded use of the fluid which may be economically beneficial and is strongly suggested for Watson Lake. Along with many other northern communities, district heating, horticulture and additional direct-use applications of geothermal energy may be economically viable for Watson Lake.

Geothermal Greenhouses

Horticultural applications could create value by providing locally grown fruits and vegetables for consumption by the Watson Lake community. Geothermal power can be used to not only heat a greenhouse, but also to supply the building with electricity for artificial lighting to assist in the optimal growth of plants. A greenhouse powered by geothermal energy could make a true year-round operation possible in Watson Lake and support the community with fresh produce at any time of the year.

Only 37.3% of Yukon residents reported fruit and vegetable consumption of 5 or more times per day in 2008.²²⁸ Initially, a design of a greenhouse powered by geothermal energy that could produce spinach all-year round for the population of Watson Lake was considered. Spinach was chosen for this design as an example of what could be grown since it is a nutrient dense vegetable, with one serving providing nutrients that include 5% of a person's daily iron and 56% of a person's daily recommended vitamin A intake.

It is also a versatile vegetable that can be worked into various meals or snacks, as well as eaten raw or frozen to be consumed at a later date.

The greenhouse is designed to provide fresh vegetables all year round to the Watson Lake community during 7 harvests, since spinach takes about 8 weeks until it can be harvested. To yield one servings of spinach per day, based on the Canada Food Guide, to each resident of Watson Lake over a two week long period after each harvest a greenhouse would need to have approximately 2,450 sqft of growing area. This area does neither account for extra space needed to maneuver in the greenhouse nor for space for packaging and storing the produce. As it is assumed that the plants will take up 60% of the total greenhouse area, the final space needed for the operation of the greenhouse is 4,083 sqft. A harvest of this size would provide the possibility for each resident of Tagish to consume fresh vegetables once per day during every week of the year. As the yield per square metre and the suggested serving size differ for each fruit and vegetable, the overall size of the greenhouse changes with its produce selection. In order to provide a serving of beets per day for every resident of Watson Lake the greenhouse would need a floor space of 6,370 sqft. Tomatoes can have a very high yield per square metre. Therefore it is suggested to add floor space to the greenhouse in order be able to supply fresh tomatoes on a regular basis to the residents of Watson Lake. A growing area of 500 sqft should suffice to produce over 20 servings of tomatoes per resident each year. An overall size of 4,900 sqft (2,940 sqft growing area) is suggested.

Table 171: Estimated vegetable production for 2,940 sqft of growing space – Watson Lake

Product	Grams per 2,940 sqft	Grams per serving	Total servings per 2,940 sqft
Spinach	438,400	32,5	13,489
Tomato	13,700,000	137	101,481
Beets	616,500	71	8,683

In cold climates, it is of importance to collect as much sunlight as possible while minimizing the negative effect that shadow has on crop growth. A length to width ratio of at least 2:1 is recommended while orienting the structure in an east-west direction. Due to the high latitude of any location within the Yukon the northern side of a greenhouse

will not collect direct sunlight. The outer surfaces that are able to utilize the sun’s light and heat will be made of 3-wall polycarbonate as it can withstand high winds and a considerable snow load while offering good insulation values. The surfaces of the greenhouse that will not be in direct contact with the sunlight will be made of an aluminum frame with insulation between the inner and outer walls. This will further minimize heat loss, allowing for a more efficient heat management in the greenhouse. The whole frame of the greenhouse can be made out of aluminum, as it is the dominant material on the market. Aluminum offers multiple advantages over wood or steel, as it is longer lasting and relatively light. Additionally, the inclination on the south facing roof should be chosen in a way that maximizes the natural solar heat gain. For the Watson Lake Greenhouse, a roof inclination of 45 degrees will be used to allow for this solar heat gain and easy removal of materials that may cover the roof such as snow.

With these design considerations in mind, a preliminary design for the greenhouse can be obtained, allowing for a rough cost estimate to be made. The greenhouse will be a long rectangular prism of 2:1 length to width with a triangular roof. This design coupled with a required floor space of 4,900 sqft produces a greenhouse with the following dimensions.

Table 172: Exemplary greenhouse design – Watson Lake

Dimension	ft
Length	99
Width	49
Height of north/south wall	10
Height of peak	40

Table 173: Exemplary greenhouse design – surface areas - Watson Lake

Dimension	ft
South Wall	990
East Wall	1,487
West Wall	1,487
North Wall	990
South Roof	4,664
North Roof	4,664
Total	14,282

The east, west and south walls as well as the south facing roof will all be made out of 3-wall polycarbonate as they will be the walls capable of using the sun’s heat and light. The north wall and north facing roof will be made out of aluminum siding/roofing with layers of insulation on the inner walls of the material to reduce heat loss. Prices are averaged prices obtained by selective market research. Real prices in Watson Lake can differ.

Table 174: Exemplary greenhouse design – material cost - Watson Lake

Material	Amount (ft²)	Cost (\$/ft²)	Total cost (\$)
Aluminum framing	972	2.5	2,431
Polycarbonate	8,628	1.99	17,170
Insulation	5,654	1.5	8,481
Aluminum roofing	4,664	3.99	18,609
Total			46,690

In order for the greenhouse to be operational during the whole year, it must be able to maintain an inside temperature of minimum 15 °C while the outside temperature is -28 °C, which is the estimated average low of the coldest month in Watson Lake. In these conditions, a minimum heat rating of 86 kW is required. This will be provided from the power plant outlet stream. A 100 kW diesel generator on 3/4 load, which would not be sufficient for the coldest hours, would require approximately 22 litres of diesel per hour to provide sufficient heating in these harsh conditions. This equates to 528 litres of diesel fuel per day, costing roughly \$602 at \$1.14 per litre. As temperatures can drop below the estimated average low, a backup heating system can be installed to avoid frost damage.

It is advisable to build the greenhouse in a location close to the binary power plant to ensure the geothermal fluid flowing from the plant to the greenhouse experiences minimal heat loss during the transport. This location should also be in close proximity to the community to allow for easy access and operation. If there is existing infrastructure near a suitable building site in Watson Lake, the greenhouse could be attached to a building, which will reduce the initial construction costs of the greenhouse, as well as to minimize its heat loss.

The next steps in the design of the greenhouse are to decide on lighting and piping. The lighting system and the pipes should be laid out evenly in order to maintain a uniform heat distribution within the greenhouse. Depending on the ground area of the greenhouse, two inflow pipes should be used, which transport the water in alternating directions in order to minimize the effect the heat loss along the piping system has on the uniformity of the temperature distribution within the building. The minimum temperature of the greenhouse should not drop below 0°C. In order to minimize heat loss when entering the greenhouse, a heated arctic entry should be considered. When designing the pipe and lighting layout it is important that it is closely linked to the alignment of the crops being grown. Between crop rows, tracks need to be wide enough to ensure effective harvesting and allowing maintenance on the heating and lighting system.

The northern latitude of Watson Lake results in widely varying daylight periods throughout the year. The longest day of the year averages approximately 18 hours long, and the shortest day of the year is roughly 5 hours long. This variation in daylight hours creates challenges for greenhouse operations in Watson Lake, and the greenhouses must have an LED lighting system in place to accommodate for these varying amounts of sun. The lighting systems used in the Alaskan Chena Hot Springs greenhouses are designed specifically for each crop in order to be as energy efficient as possible. Similarly, greenhouses constructed in Watson Lake should be energy conscious with their lighting system, using LED lighting for their energy efficiency, and to accommodate for fluctuating daylight hours throughout the year.

Due to the low soil temperatures in a northern environment like Watson Lake, the use of raised planting beds is advisable. Additionally, raised beds can make harvesting the produce easier as the beds are raised to working level.

As plants need water and fertilizer for their growth, choices on irrigation systems and fertilizer selection have to be made. For Watson Lake a fertigation system would be preferable, which means that a fertilizer water solution is used. This system works on a drip irrigation basis with added root moisture sensors, which ensure an optimal moisture and nutrient level at all times.

Ventilation systems offer effective temperature adjustment with little effort. It is advisable to install an automated system, which regulates the indoor temperature through automated opening and closing of vents.

The remaining temperature after the greenhouse heating application could be used for further cascaded applications such as drying fresh food products, heated storage or other types of public facilities, district heating and the heating of public swimming pools. These applications that could be beneficial to Watson Lake, in addition to being powered in an affordable and efficient way by geothermal power will be discussed in further detail below.

Drying of Greenhouse products

The drying of food is an application that is can be particularly meaningful to northern communities, since it is a way to preserve fruits and vegetables that are not abundant in these climates for future consumption. Though it is important to note that dried fruits and vegetables cannot replace their fresh versions since there is some nutrient loss caused by dehydration, these products can be used to supplement diets and have a high caloric density with dried fruits and vegetables containing up to five time more calories than their fresh counterparts. A food drying facility in Watson Lake could use the excess heat that is available after heating the greenhouse to heat up the drying chamber. A dehumidifier and an air pump can be electrically powered and should be used in wet weather. Good primary drying conditions require a relative humidity between 20% and 50% and an air velocity of approximately 3 m/s. For perfect results a second drying process with higher temperatures and lower air velocity can be added.

Space heating

Watson Lake is the third largest community in the Yukon, with several municipal and provincial government buildings, as well as a public library, community centre and visitor information centre. The dense settlement structure in part of Watson Lake makes a district heating system a potentially attractive application for the community. Heat derived from the geothermal fluid flowing out of the power plant could provide a more affordable and environmental way to heat the larger buildings of the town.

Watson Lake could also be home to geothermally heated community buildings that could be used for community social events and storage, among many other potential uses. A space heated to room temperature could be used in part for animal husbandry, more specifically the raising of chickens for eggs and meat throughout the winter. This could be an important endeavour for a community like Watson Lake that cannot keep animals all year round outdoors due to its cold climate. Also, eggs, which are a source of protein, are more expensive in Watson Lake than in other parts of Canada, costing close to \$4.56 for a dozen eggs compared to in \$3.22 Toronto.

Aquaculture

Different species of fish could be raised for human consumption all year round in Watson Lake through the use of aquaculture powered and heated by geothermal energy.

Some examples of fish that are native to this region are Arctic grayling, northern pike and lake trout. For this example, an aquaculture system for the farming of rainbow trout, a commonly cultured fish that cannot already be found in Watson Lake is suggested. Rainbow trout is a good source of protein with an average marketable size fish, between 0.5 to 1.0 kg and a good source of Omega-3 essential acids. Trout will exhibit optimum growth at 17°C, though they can survive between temperatures of 0°C to 27°C. This species of trout will take about 6 to 8 months to reach their optimal market size.

For fish of 500g in size, the tank should be able to maintain a flow through of 5 l/min/m³ and can produce about 50 fish per m³. For a community like Watson Lake a reasonably large tank could be built and the fish produced could be frozen for later consumption or to be sold to nearby communities. To complete all steps of fish farming in Watson Lake, hatching and rearing tanks will also need to be constructed. The location of Watson Lake close to a freshwater source is ideal since this water could be used to fill the tanks in which to grow the trout.

General assumptions can be made about the piping that will be required for the heat exchanger and their location in relation to the tank. For example, steel or FRP

(Fibreglass Reinforced Plastic) piping could be used to carry the hot fluid to and from the heat exchanger and PVC piping could be used to circulate the warm fluid through the tank. A method to reduce heat loss due to the cold northern temperatures and evaporation all year round from the tanks would be to cover them with a roof structure similar to that of a greenhouse and heat the space surrounding the tank.

One way to simplify the aquaculture system is to grow vegetation on the surface of the water that will enable some feeding of the trout, as well as to filter the water in the tanks. For example, numerous floating and rooted water plants could be grown on the surface of the water in the fish tanks, like duck weed, water lettuce, water hyacinth, water cress and water parsnip. The plants will reproduce naturally and survive off of nutrients in the water, sunlight and the carbon dioxide produced by the fish. In return, the plants oxygenate the water and could potentially be a source of food for the fish.

Geothermal heated swimming pool

There is already a 15,000 sq. ft. swimming pool operating in a building adjacent to the Morgan Chaddock Recreation Centre in Watson Lake. However, it only operates seasonally and Watson Lake residents have expressed their desire for the pool to be opened all year round.²²⁹

During the summer when the pool is open, it is heated by the waste heat recovery system of the Yukon Electric diesel generators that provide power to Watson Lake. This heat recovery system also heats the changing rooms, showers and mechanical room at the pool. Swimming pools are normally heated to between 25 and 28 °C.

Having the pool operate year round through the use of geothermal energy would be beneficial for the community as it would provide another way for residents to exercise regularly in the winter months and is a measure to improve the quality of life in general.

Additional considerations of the feasibility of geothermal energy production in Watson Lake

The Sa Dena Hes Mine is located approximately 45 km from Watson Lake. This mine has been in a state of permanent closure since November 1992, and closure and

reclamation activities recently ceased in 2015. The mine's closure was primarily the result of low metal prices and poor market conditions in the early 1990s, and a second abandonment occurred in the late 1990s for the same reasons. The mine site has been host to an underground mine, ore handling facilities, a 1,500-tonne/day conventional mill, load out facilities, tailings and reclamation system, shops, warehouse, security and first-aid office. In addition, the site had a 200-person camp, administration building, and a 6.2 MW power plant.²³⁰

During its construction and operation, the mine had need for significant power sources in order to install its infrastructure and upkeep its daily operations. If the mine reopens due to renewed market demand and higher zinc prices, it will need power for its operations. The instalment of a binary geothermal power plant close to Watson Lake and the mine site may be economically viable then.

Mine sites located on geothermal hotspots may have access to geothermal fluids, as a result of drilling and the depth of the actual mine infrastructure (tunnels and shafts). More recently, in tandem with mining operations, both operational and closed mine sites are being used as geothermal fluid conduits. There are functional examples of mine sites around the world that are being used as low-temperature geothermal reservoirs, and Sa Dena Hes could be used similarly. Also, it could be cost-efficient to provide the energy required by the mine through geothermal power.²³¹

In its closed state, the Sa Dena Hes mine could be leveraged for its easier access to geothermal resources similarly to how the Springhill, Nova Scotia mine site is being used today. Near the town approximately 49 billion litres of water from the former mine operations absorb geothermal heat. The Springhill geothermal system is important to the economy of the town as it saves \$110,000 in energy costs in the heating of their community centre alone. Springhill has had high levels of success with their simple geothermal system and exists as an excellent example of the use of existing mine infrastructure to minimize the infrastructural start-up costs of geothermal systems.

Other types of power being considered to replace diesel in Watson Lake

Watson Lake is in the process of trying to come to an agreement with the Government of the Yukon and Yukon Electric to be able to begin using liquefied natural gas (LNG) as a power source. Natural gas is cooled to -162°C at which it is in a liquid state. This increases the energy density of the fluid, making it less costly to transport and store. The fuel is re-vaporized for electricity generation. LNG is a less costly alternative to diesel and produces fewer greenhouse gases and air pollutants. There would be an initial cost to converting diesel generators to be able to be powered with both diesel and LNG.²³²

Hydro electricity is, like geothermal, an environmentally friendly alternative to diesel. A hydroelectric plant construction feasibility study was carried out in Watson Lake in 2014. However, all three of the suggested hydroelectric power plants that have been designed will only meet part of Watson Lake’s demand for energy between 45-80% of the town’s power, therefore it is still important to consider the role that geothermal energy could play in this community.

Cost of Energy

Table 175: Residential energy prices in Watson Lake

	Residential Service, non-government ²³³	Residential Service, government ²³⁴
Customer charge	\$14.65	\$18.47
Energy charge for the first 1,000 kWh	12.14 ¢/kWh	16.47 ¢/kWh
Energy charge between 1,001 – 2,500 kWh	12.82 ¢/kWh	17.47 ¢/kWh
Energy charge for energy in excess of 2,500 kWh	13.99 ¢/kWh	18.85 ¢/kWh

Table 176: General service energy prices in Watson Lake

	General Service, non-government ²³⁵	General Service, government - municipal ²³⁶	General Service, government – federal & territorial ²³⁷
Demand Charge for all kW of billing demand*	\$7.39 / kW	\$7.39 / kW	\$12.31 / kW
Energy charge for the first 2,000 kWh	10.00 ¢/kWh	10.00 ¢/kWh	13.81 ¢/kWh

Energy charge between 2,001 – 15,000 kWh	12.88 ¢/kWh	12.88 ¢/kWh	15.00 ¢/kWh
Energy charge between 15,001 – 20,000 kWh	15.68 ¢/kWh	15.68 ¢/kWh	20.00 ¢/kWh
Energy charge for energy in excess of 20,000 kWh	12.86 ¢/kWh	12.86 ¢/kWh	12.86 ¢/kWh

*where the billing demand may be estimated or measured and will be the greater of the following: A) The highest metered demand during the billing period. B) The highest metered demand during the 12 months ending with the current billing month, excluding the months April through September. C) The estimated demand. D) 5 kilowatts.

Table 177: Watson Lake 2015 residential fuel prices²³⁸

Month	Furnace Oil (¢/L)	Arctic Stove Oil (¢/L)	Propane (\$/500 gallon tank)
December	100.8	106.4	71.3
November	109.2	113.5	74.3
October	109.2	113.5	82.4
September	106.2	110.0	81.0
August	107.2	111.5	79.3
July	107.6	112.3	79.3
June	109.3	114.0	82.5
May	111.7	115.9	85.6
April	108.8	113.0	84.9
March	118.6	119.6	84.5
February	117.3	118.7	84.5
January	115.7	118.5	87.7

Infrastructure

Table 178: Watson Lake infrastructure profile

List of Relevant Infrastructure	
Transportation Infrastructure	Tourism infrastructure
Highway access via Klondike & Alaska Highways	Hotels
Airport with 5,500 foot paved runway	Restaurants
	RV park & campgrounds
Communication Infrastructure	Emergency Services
Cell reception: Latitude Wireless	Hospital (24/7 acute care services)
High speed internet: NorthwTel	Health Centre
Landline phone service: NorthwTel	Private Medical Clinic
	Ambulance (staff/volunteer)
	Medevac available 24 hours
	Fire (staff/volunteer)
	RCMP detachment
Business Infrastructure	Housing Infrastructure

Municipal government office	417 Private dwellings
CIBC Bank	350 Normally occupied dwellings
Grocery stores	235 Single detached houses
Hardware stores	0 Apartments (5+ storeys)
Several auto services	35 Apartments (<5 storeys)
Various contractors and equipment outfitters	60 Movable dwellings
	20 Semi-detached houses
	0 Row houses
	5 Duplexes
Educational Infrastructure	Recreation Infrastructure
Johnson Elementary School (grades k – 7)	Seasonal heated swimming pool
Watson Lake Secondary School (grades 8 – 12)	Hockey and curling arena with artificial ice
Yukon College Watson Lake Campus	
Watson Lake Library	Fitness centre

Economics

Table 179: Watson Lake 2015 Spatial Price Index (Whitehorse = 100)²³⁹

Meat	107.7	Household Operations	108.1
Dairy/eggs	100.0	Health and Personal Care	127.1
Fruit/vegetables	114.2	Gasoline	98.9
Bread/cereal	110.0	Cigarettes	104.7
Other Foods	115.1	Total Survey Items	108.2

Industries

Watson Lake is often referred to as the “Gateway to the Yukon.” It is the first community in the Yukon when driving from British Columbia, and is at the intersection of two major highways: the Alaska Highway and the Klondike Highway. Watson Lake is therefore a key transportation, distribution, and communication hub for the logging, tourism, mining, and outfitting industries.

The Wolverine mine is located 190 km north of Watson Lake. Please refer to the Ross River section for details on the mining operation there. Watson Lake is also conveniently located for the mining service industry that provides services to the Cantung mine in the North West Territories and the Cassiar mine in British Columbia.

Whitehorse

Overview

Whitehorse is the capital city of the Yukon, and is the home to over two-thirds of the territory's entire population. It is located traditional territory of the Ta'an Kwäch'än and Kwanlin Dün First Nations. Whitehorse offers a full range of visitor services including two golf courses, hot springs and an international airport. Whitehorse has several supermarkets, retail stores, vehicle and equipment rentals, and all services that would be expected in any major Canadian city.



Demographics

Table 180: Whitehorse 2011 demographics²⁴⁰

Whitehorse, source: Google

Classification	City	Percent of population over 15	81.9%
Population in 2011	23,276	Total private dwellings	9,649
Population in 2006	20,461	Private dwellings occupied by usual residents	9,309
2006 to 2011 population change	+13.8%	Land area	416.54 km ²
Median age	37.1	Population density	55.9 / km ²

Geothermal Potential

Whitehorse's geothermal potential has been subject to historic research: Since the 1970's subsurface temperatures have been analyzed in Whitehorse. In 1976 Hydrogeological Consultants Ltd found two thermal anomalies - in Riverdale and Porter Creek. Riverdale was the target area of exploratory drilling in 1980, which confirmed the geothermal heating process and found a sharp temperature increase at about 60 meters

below ground level. In 2007 and 2008 EBA collected data from 10 water wells located within the city limits in order to test it via major ion analyses, geothermometer calculations and isotopic analyses. The test locations were chosen in correspondence with historical data, reports and anecdotal information.²⁴¹

EBA's temperature measurements were undertaken in 2 – 10 meter intervals starting at the well's deepest accessible point. Bottom well temperatures ranged from 2.9°C (96m deep) to 8.8°C (145m deep). Geothermal gradients ranged from 1.28°C/100m at Wolf Creek to 6.10°C/100m at Porter Creek. EBA concludes that differences exist, but a more detailed model is needed to obtain essential information on the hydrogeological features of the area.

The geothermometer calculations were mainly based on Na-K-Ca/Mg, quartz and chalcedony geothermometers. The results indicate reservoir temperatures between 20°C (Porter Creek) and 52°C (Vanier School).²⁴²

Currently the geothermal potential in and around Whitehorse is used to prevent the municipality's heating and sewage system from freezing during the winter months. The Whitehorse Rapids Fish Hatchery currently uses geothermally heated groundwater for their operation and for heating the facilities. Considering the subsurface temperature profile, the use of geothermal energy in Whitehorse can be vastly enhanced.

A geothermal industry located in Whitehorse can easily function as a role model for other cities in the Canadian North and it is suggested that Whitehorse becomes a centre for renewable energy education in the Canadian North

Table 181: Temperature at depth & technical geothermal potential in Whitehorse

Depth in m	Temperature in °C	Technical Potential with 5% recovery in MW	Technical Potential with 14% recovery in MW	Technical Potential with 20% recovery in MW
1,500	43	-	-	-
2,500	72	2.05	5.74	8.19
3,500	100	4.77	13.36	19.08

4,500	116	5.27	14.76	21.08
-------	-----	------	-------	-------

Whitehorse’s geothermal potential allows more than 5MW of electricity to be produced from drilling depths of 2,500m when a 14 % recovery factor is used.

The evaluation of project costs for Whitehorse is not 100% accurate. CanGEA has undertaken calculations for binary power plant costs in the past and the results of these calculations are used in this report. The assumptions used for these calculations are not identical to the real local circumstances.

CanGEA’s archive states the cost for a 5MW_e/66MW_t CHP project set in a Hot Sedimentary Aquifer environment in the Canadian North with a drilling depth of 2100m to be roughly \$46 million. A cost table can be found in Table 182. The actual cost for Whitehorse would be higher, as the drilling depth would exceed 2100m.

Table 182: Cost table for an exemplary 5MW_e/66MW_t CHP project in northern Canada (HSA environment).

Cost Category	Cost in million \$
Exploration and Drilling	20.7
Well Pumps	3.2
ORC Unit	11.8
Facility	2.6
Construction	0.9
Materials	0.7
Engineering	2.2
Contingency	4.2

Assuming a capacity factor of 0.9, the potential to sell all produced electricity (39,420,000 kWh/a), constant achievable prices, a project lifetime of 50 years, a Weighted Average Cost of Capital (WACC) of 8%, construction cost payable up front and disregarding annual maintenance cost, the break even price for power production only is approximately \$0.09/kWh. The break-even price for Whitehorse would be slightly higher. The break-even price can be lowered / the NPV can be increased by adding a cascaded heat system that could be used for additional profit generation. The installation of a geothermal power plant in Whitehorse might be a positive development for the

hydroelectric grid, since geothermal could level some of variability in the seasonal generation capacity.

It is assumed that the temperature of the geothermal fluid leaving the binary power plant will decrease by about 17 °C and allow for further cascaded use, which may be economically beneficial and is strongly suggested for Whitehorse. Along with many other northern communities, district heating, horticulture and additional direct-use applications of geothermal energy may be economically viable for Whitehorse.

Geothermal Greenhouses

Horticultural applications could create value by providing locally grown fruits and vegetables for consumption by the Whitehorse community. Geothermal power can be used to not only heat a greenhouse, but also to supply the building with electricity for artificial lighting to assist in the optimal growth of plants. A greenhouse powered by geothermal energy could make a true year-round operation possible in Whitehorse and support the community with fresh produce at any time of the year. There are already multiple grocery stores operating in Whitehorse, which provide fresh food to the city's inhabitants. For that reason a large scale greenhouse to produce fruits and vegetables for the people of Whitehorse may not be important as for the smaller and more remote communities of the Yukon in terms of population health.

Only 37.3% of Yukon residents reported fruit and vegetable consumption of 5 or more times per day in 2008.²⁴³ Initially, a design of a greenhouse powered by geothermal energy that could produce spinach all-year round for the population of Whitehorse was considered. Spinach was chosen for this design as an example of what could be grown since it is a nutrient dense vegetable, with one serving providing nutrients that include 5% of a person's daily iron and 56% of a person's daily recommended vitamin A intake. It is also a versatile vegetable that can be worked into various meals or snacks, as well as eaten raw or frozen to be consumed at a later date.

The greenhouse is designed to provide fresh vegetables all year round to the 4,000 members of the Whitehorse community during 7 harvests, since spinach takes about 8 weeks until it can be harvested. To yield one serving of spinach per day, based on the



Canada Food Guide, to 4,000 residents of Whitehorse over a week long period after each harvest a greenhouse would need to have approximately 6,125 sqft of growing area. This area does neither account for extra space needed to maneuver in the greenhouse nor for space for packaging and storing the produce. As it is assumed that the plants will take up 60% of the total greenhouse area, the final space needed for the operation of the greenhouse is approximately 10,200 sqft. A harvest of this size would provide the possibility for each resident of Whitehorse to consume fresh vegetables once per day during every week of the year. As the yield per square metre and the suggested serving size differ for each fruit and vegetable, the overall size of the greenhouse changes with its produce selection. Tomatoes can have a very high yield per square metre. Therefore it is suggested to add floor space to the greenhouse in order be able to supply fresh tomatoes on a regular basis to the residents of Whitehorse. A growing area of 1200 sqft should suffice to produce over 10 servings of tomatoes per resident each year. An overall size of 12,200 sqft (7,320 sqft growing area) is suggested.

Table 183: Estimated vegetable production for 7,320 sqft of growing space - Whitehorse

Product	Grams per 7,320 sqft	Grams per serving	Total servings per 7,320 sqft
Spinach	1,088,000	32,5	33,477
Tomato	34,000,000	137	251,852
Beets	1,530,000	71	21,549

In cold climates, it is of importance to collect as much sunlight as possible while minimizing the negative effect that shadow has on crop growth. A length to width ratio of at least 2:1 is recommended while orienting the structure in an east-west direction. Due to the high latitude of any location within the Yukon the northern side of a greenhouse will not collect direct sunlight. The outer surfaces that are able to utilize the sun's light and heat will be made of 3-wall polycarbonate as it can withstand high winds and a considerable snow load while offering good insulation values. The surfaces of the greenhouse that will not be in direct contact with the sunlight will be made of an aluminum frame with insulation between the inner and outer walls. This will further minimize heat loss, allowing for a more efficient heat management in the greenhouse. The whole frame of the greenhouse can be made out of aluminum, as it is the dominant material on the market. Aluminum offers multiple advantages over wood or steel, as it is

longer lasting and relatively light. Additionally, the inclination on the south facing roof should be chosen in a way that maximizes the natural solar heat gain. For the Whitehorse Greenhouse, a roof inclination of 45 degrees will be used to allow for this solar heat gain and easy removal of materials that may cover the roof such as snow.

With these design considerations in mind, a preliminary design for the greenhouse can be obtained, allowing for a rough cost estimate to be made. The greenhouse will be a long rectangular prism of 2:1 length to width with a triangular roof. This design coupled with a required floor space of 12,200 sqft produces a greenhouse with the following dimensions.

Table 184: Exemplary greenhouse design – Whitehorse

Dimension	ft
Length	156
Width	78
Height of north/south wall	10
Height of peak	63

Table 185: Exemplary greenhouse design – surface areas - Whitehorse

Dimension	ft
South Wall	1,562
East Wall	3,251
West Wall	3,251
North Wall	1,562
South Roof	11,612
North Roof	11,612
Total	32,850

The east, west and south walls as well as the south facing roof will all be made out of 3-wall polycarbonate as they will be the walls capable of using the sun’s heat and light. The north wall and north facing roof will be made out of aluminum siding/roofing with layers of insulation on the inner walls of the material to reduce heat loss. Prices are averaged prices obtained by selective market research. Real prices in Whitehorse can differ.

Table 186: Exemplary greenhouse design – material cost - Whitehorse

Material	Amount (ft²)	Cost (\$/ft²)	Total cost (\$)
Aluminum framing	2,3131	2.5	5,782
Polycarbonate	19,676	1.99	39,156
Insulation	13,174	1.5	19,761
Aluminum roofing	11,612	3.99	46,332
Total			111,031

In order for the greenhouse to be operational during the whole year, it must be able to maintain an inside temperature of minimum 15 °C while the outside temperature is -20 °C, which is the estimated average low during the coldest month of the year in Whitehorse. In these conditions, a minimum heat rating of 162 kW is required. This could be provided from the power plant outlet stream. A more than sufficient 175 kW diesel generator, on full load would require 48.1 litres of diesel per hour to provide sufficient heating in these harsh conditions. This equates to 1,154 litres of diesel fuel per day, costing roughly \$1,316 at \$1.14 per litre. As temperatures can drop below the estimated average low, a backup heating system can be installed to avoid frost damage.

It is advisable to build the greenhouse in a location close to the binary power plant to ensure the geothermal fluid flowing from the plant to the greenhouse experiences minimal heat loss during the transport. This location should also be in close proximity to the community to allow for easy access and operation. If there is existing infrastructure near a suitable building site in Whitehorse, the greenhouse could be attached to a building, which will reduce the initial construction costs of the greenhouse, as well as to minimize its heat loss.

The next steps in the design of the greenhouse are to decide on lighting and piping. The lighting system and the pipes should be laid out evenly in order to maintain a uniform heat distribution within the greenhouse. Depending on the ground area of the greenhouse, two inflow pipes should be used, which transport the water in alternating directions in order to minimize the effect the heat loss along the piping system has on the uniformity of the temperature distribution within the building. The minimum temperature of the greenhouse should not drop below 0°C. In order to minimize heat

Canadian Geothermal Energy Association
PO Box 1462 Station M, Calgary, Alberta, T2P 2L6, Canada
info@cangea.ca - www.cangea.ca



loss when entering the greenhouse, a heated arctic entry should be considered. When designing the pipe and lighting layout it is important that it is closely linked to the alignment of the crops being grown. Between crop rows, tracks need to be wide enough to ensure effective harvesting and allowing maintenance on the heating and lighting system.

The northern latitude of Whitehorse results in widely varying daylight periods throughout the year. The longest day of the year averages approximately 18 hours long, and the shortest day of the year is roughly 5 hours long. This variation in daylight hours creates challenges for greenhouse operations in Whitehorse, and the greenhouses must have an LED lighting system in place to accommodate for these varying amounts of sun. The lighting systems used in the Alaskan Chena Hot Springs greenhouses are designed specifically for each crop in order to be as energy efficient as possible. Similarly, greenhouses constructed in Whitehorse should be energy conscious with their lighting system, using LED lighting for their energy efficiency, and to accommodate for fluctuating daylight hours throughout the year.

Due to the low soil temperatures in a northern environment like Whitehorse, the use of raised planting beds is advisable. Additionally, raised beds can make harvesting the produce easier as the beds are raised to working level.

As plants need water and fertilizer for their growth, choices on irrigation systems and fertilizer selection have to be made. For Whitehorse a fertigation system would be preferable, which means that a fertilizer water solution is used. This system works on a drip irrigation basis with added root moisture sensors, which ensure an optimal moisture and nutrient level at all times.

Ventilation systems offer effective temperature adjustment with little effort. It is advisable to install an automated system, which regulates the indoor temperature through automated opening and closing of vents.

The remaining temperature after the greenhouse heating process might be used for further cascaded applications such as drying fresh food products, heated storage or

other types of public facilities, district heating and the heating of public swimming pools. These applications that could be beneficial to Whitehorse, in addition to being powered in an affordable and efficient way by geothermal power will be discussed in further detail below.

Drying of Greenhouse products

The drying of food is an application that is can be particularly meaningful to northern communities, since it is a way to preserve fruits and vegetables that are not abundant in these climates for future consumption. Though it is important to note that dried fruits and vegetables cannot replace their fresh versions since there is some nutrient loss caused by dehydration, these products can be used to supplement diets and have a high caloric density with dried fruits and vegetables containing up to five time more calories than their fresh counterparts. A food drying facility in Whitehorse could use the excess heat that is available after heating the greenhouse to heat up the drying chamber. A dehumidifier and an air pump can be electrically powered and should be used in wet weather. Good primary drying conditions require a relative humidity between 20% and 50% and an air velocity of approximately 3 m/s. For perfect results a second drying process with higher temperatures and lower air velocity can be added.

Other applications

Whitehorse is the largest community in the Yukon, with several municipal and provincial government buildings, as well as a public library, community centre and visitor information centre. The dense settlement structure in parts of Whitehorse makes a district heating system a potentially attractive application for the city.

There already exist aquaculture facilities in Whitehorse like the Whitehorse Rapids Fish Hatchery that actually use some geothermal energy in their operations to maintain the water temperature. However, there are other aquaculture facilities like Icy Waters Arctic Char, which could potentially benefit from having geothermal fluids to heat the freshwater in which their fish are grown. The energy requirements and associated costs for aquaculture, even in a city like Whitehorse with a large hydro-electric grid, continues to be daunting for companies like Nutraponics considering the construction and

operations of an aquaponics facility that combines aquaculture and hydroponics in Whitehorse.²⁴⁴ Therefore constructing a system to transport geothermal fluid to aquaculture facilities to fulfill their heat requirements could have an important impact on businesses already in Whitehorse, as well as expanding the aquaculture industry of the city.

Whitehorse could also be home to geothermally heated community buildings that could be used for community social events and storage, among many other potential uses. As many other communities in the Yukon, Whitehorse could also profit from geothermally heated swimming pools, aquaculture, etc.

Cost of Energy

Whitehorse is a part of the main hydroelectric grid.

Table 187: Residential energy prices in Whitehorse

	Residential Service, non-government ²⁴⁵	Residential Service, government ²⁴⁶
Customer charge	\$14.65	\$18.47
Energy charge for the first 1,000 kWh	12.14 ¢/kWh	16.47 ¢/kWh
Energy charge between 1,001 – 2,500 kWh	12.82 ¢/kWh	17.47 ¢/kWh
Energy charge for energy in excess of 2,500 kWh	13.99 ¢/kWh	18.85 ¢/kWh

Table 188: General service energy prices in Whitehorse

	General Service, non-government ²⁴⁷	General Service, government - municipal ²⁴⁸	General Service, government – federal & territorial ²⁴⁹
Demand Charge for all kW of billing demand*	\$7.39 / kW	\$7.39 / kW	\$12.31 / kW
Energy charge for the first 2,000 kWh	10.00 ¢/kWh	10.00 ¢/kWh	13.81 ¢/kWh
Energy charge between 2,001 – 15,000 kWh	12.88 ¢/kWh	12.88 ¢/kWh	15.00 ¢/kWh
Energy charge between 15,001 – 20,000 kWh	15.68 ¢/kWh	15.68 ¢/kWh	20.00 ¢/kWh

Energy charge for energy in excess of 20,000 kWh	12.86 ¢/kWh	12.86 ¢/kWh	12.86 ¢/kWh
---	-------------	-------------	-------------

*where the billing demand may be estimated or measured and will be the greater of the following: A) The highest metered demand during the billing period. B) The highest metered demand during the 12 months ending with the current billing month, excluding the months April through September. C) The estimated demand. D) 5 kilowatts.

Table 189: Whitehorse 2015 residential fuel prices²⁵⁰

Month	Furnace Oil (¢/L)	Arctic Stove Oil (¢/L)	Propane (\$/500 gallon tank)
December	99.1	101.3	71.3
November	101.5	104.3	74.3
October	102.5	105.7	82.4
September	103.2	105.3	81.0
August	106.3	107.7	79.3
July	105.7	106.9	79.3
June	105.5	108.4	82.5
May	106.6	109.1	85.6
April	105.8	108.5	84.9
March	107.4	109.9	84.5
February	107.8	109.0	84.5
January	108.0	109.6	87.7

Infrastructure

Table 190: Whitehorse infrastructure profile

List of Relevant Infrastructure	
Transportation Infrastructure	Tourism infrastructure
Highway access via Alaska Highway Erik Nielsen Whitehorse International Airport Whitehorse Water Aerodrome (floatplane base)	Hotels Restaurants RV park & campground
Communication Infrastructure	Emergency Services
Cell reception: Latitude Wireless High speed internet: NorthwesTel Landline phone service: NorthwesTel	Hospital (24/7 acute care services) Health centre & other services Ambulance (staffed 24 hours) Medevac available 24 hours Fire (staffed 24 hours) RCMP detachment Whitehorse Search and Rescue
Business Infrastructure	Housing Infrastructure
All services to be expected in any major city	9,649 Private dwellings 9,309 Normally occupied dwellings 5,080 Single detached houses

	5 Apartments (5+ storeys)
	1,460 Apartments (<5 storeys)
	925 Movable dwellings
	860 Semi-detached houses
	500 Row houses
	435 Duplexes
Educational Infrastructure	Recreation Infrastructure
11 Primary schools	Canada Games Centre
3 High schools	Takhini Arena
1 K-12 Francophone school	Mount McIntyre Recreation Centre
1 Yukon College Main Campus	Mt. Sima Ski Resort

Economics

Table 191: Whitehorse 2015 Spatial Price Index (Whitehorse = 100)

Meat	100.0	Household Operations	100.0
Dairy/eggs	100.0	Health and Personal Care	100.0
Fruit/vegetables	100.0	Gasoline	100.0
Bread/cereal	100.0	Cigarettes	100.0
Other Foods	100.0	Total Survey Items	100.0

Industries

Whitehorse is the economic centre of the Yukon. With over two-thirds of the entire territory's population, its large population drives most of the territorial economy. Government is the single largest source of economic activity in Whitehorse, followed by trades and goods producing industries. Whitehorse is home to the largest non-industrial electricity consumers of Territory. Some non-industrial noticeable examples include:

- Canada Games Centre
- Main Administration Building (includes legislature)
- Elijah Smith Building (includes many gov't branches/offices)
- Yukon College
- Whitehorse Hospital

Canadian Geothermal Energy Association
PO Box 1462 Station M, Calgary, Alberta, T2P 2L6, Canada
info@cangea.ca - www.cangea.ca



Community Comparison Table

The following matrix entails a comparison for all analyzed communities in the Yukon and displays the key infrastructural indicators that were discussed in the according community chapter.



Cities	Temperature data				Cost of Living				Population	
	T in °C at 1.5 km	T in °C at 2.5 km	T in °C at 3.5 km	T in °C at 4.5 km	CPI (Whitehorse = 100)	Food Prices (vegetables) (Whitehorse=100)	Cost of Electricity (residential) (¢/kWh) (more than 2,500 kWh annually)	Furnace oil (¢/kWh) In Dec 2015	Population in 2011	Population growth from 2006 to 2011
Beaver Creek	37	63	88	112	No data	No data	13.99	107.7	103	-8.0%
Burwash Landing	30	51	71	90	No data	No data	13.99	104.0	95	+30.1%
Carcross	51	85	118	139	No data	No data	13.99	100.9	298	+3.2%
Carmacks	54	92	129	165	112.6	126.9	13.99	101.6	503	+18.4%
Dawson City	30	53	75	96	116.2	121.2	13.99	107.1	1,319	-0.6%
Destruction Bay	29	49	69	88	No data	No data	13.99	100.9	35	-36.4%
Faro	39	65	91	116	113.3	127.1	13.99	101.9	344	+0.9%
Haines Junction	25	43	60	76	116.0	110.6	13.99	98.8	593	+0.7%
Mayo	31	53	73	94	119.4	166.5	13.99	112.2	226	8.9%
Mount Lorne	47	78	96	114	No data	No data	13.99	No data	408	+10.3%
Old Crow	17	30	42	53	180.5	177.8	30.77	No data	245	-3.2%
Ross River	52	78	104	129	120.0	142.0	13.99	102.9	352	+12.5%
Tagish	53	88	109	129	No data	No data	13.99	100.9	391	+21.4%
Teslin	65	109	152	178	113.2	117.6	13.99	101.6	122	-13.5%
Watson Lake	43	72	101	128	108.2	114.2	13.99	100.8	802	-5.2%
Whitehorse	43	72	100	116	100.0	100.0	13.99	99.1	23,276	+13.8%



Case Studies in Northern Communities

Yukon Geothermal Energy Report
2016

Introduction

The following section reviews different cases, which are spread throughout Alaska, the Yukon and the Northwest Territories. The cases differ distinctly from each other. Given their variation, they serve to illustrate some of the essential considerations for a successful project, as well as for economic and technical feasibility.

If appropriate, the project value was assessed by a Net Present Value (NPV) calculation. The NPV method uses a complex conceptual approach to assess the value of a certain project. The two main principles of this method are

- the time value of money – it is more desirable to obtain a certain amount of money earlier than later, and
- the risk premium – the risk of not receiving a certain amount of money depreciates its worth.²⁵¹

The mathematical foundation for the NPV method is the sum of estimated future cash flows, which are discounted with a distinct discount rate.²⁵² The appropriate definition of cash flow is tailored to each individual project and can be found in the project description. The discount rate is chosen in a way that reflects the risk of the cash flows. As the Weighted Average Costs of Capital (WACC) are expected to provide a realistic NPV estimation when used as the discount factor, this approach is suggested when possible. The WACC is a calculative parameter that reflects the average rate that a company has to pay to all its security holders while weighing equity and debt capital appropriately.²⁵³

Case Study: Takhini Hot Springs, Yukon

Introduction

Being located in close proximity to the territory's capital Whitehorse, Takhini Hot Springs serves as a spa destination for Yukon residents and tourists alike. This natural hot spring area is fed by geothermal fluid, which stems from a local aquifer.

Past Geothermal / Energy Developments

Takhini Hot springs has been used as an area for bathing and washing by different Indigenous Peoples for centuries. However, the beginning of commercial use of the area can be dated to the first half to the 20th century. Currently the development includes two hot pools, which operate at different temperatures (42°C and 36°C) and are used for spa treatments. A restaurant and accommodation services, which include a campground and a hostel exist as well. The pools are owned by Andrew Umbrich and Lauren O'Coffey, who welcome the idea of further development of the resource.²⁵⁴

Geothermal Potential

The natural hot spring is not stimulated by any pumping system and supplies geothermal water with an average temperature of 47°C and a flow rate of 6.42l/s. The maximum reservoir temperature is quoted by the owners to be 95°C. With this down hole temperature, further research concerning the possibility of using a binary power plant to produce electricity is strongly suggested. The surface water's chemical composition can be found in Table 192. The mineral-rich water is marketed as healthy.

Table 192: Chemical components of the geothermal surface water at Takhini Hot Springs

SO ₄	1740
CaCO ₃	104
Ca	580
CaI	1.5

F	3.6
Fe ²⁺	0.9
Mg	78.2
Na	36.5
K	8.7
Si	19.8

The water temperature is high enough to allow further use after the bathing and spa application. With a runoff temperature of roughly 38 °C, the water could be used as a source for space heating and horticulture. Both applications would tie in well with the existing infrastructure and business model.

A space heating system for the changing rooms and the restaurant is installed and contributes to lowering the heating cost and reducing greenhouse gas emissions. Plastic pipes are used to direct the runoff water from the pools to the building. Originally designed to account for up to 70% of the yearly heating demand, mineral scalings have reduced the geothermal contribution to only 20%. Currently the whole natural flow from the Hot Spring is used for the spa/bathing application first. In order to stimulate a higher flow rate, pumping systems would be necessary. This would have the advantage of using hotter geothermal water for other applications than bathing and would increase their economical feasibility. As of 2015, four wells have been drilled on the property. The wells' temperature was measured at 35°C at a depth of 61 m. The owners would like to use the water from these wells to create additional pools and intensify the geothermal contribution to space heating on site.

Use for residential heating is limited, as the area is sparsely populated. An assessment of the geothermal potential in this area is underway, but first results indicate enough heat to potentially heat 200 houses, each measuring 2,000ft².

A horticulture application is possibly profitable as the chefs of the local restaurant could use local produce as ingredients for their meals. A focus on local ingredients has been proven successful in tourist restaurants and might be a possible trigger for higher profit as local ingredients bring the possibility to adjust price levels accordingly.²⁵⁵

Economic Assessment

Annually, Takhini Hot Springs is visited by approximately 50,000 people. It is not publicly available information, how many of these visitors are one-time-only visitors and how many purchase passes for multiple visits. The investment and running costs are not available, either. A full quantitative economic assessment is therefore not feasible. Nevertheless, this chapter provides a conceptual approach for the assessment of a business like Takhini Hot Springs.

The economic assessment of the Takhini Hot Springs is focused on the pool and spa application and uses the NPV method, which is explained in the beginning of this chapter.

For Takhini Hot Springs, the cost portion of the cash flow calculation can be assumed as:

$$C = C_i + C_r$$

where C_i are the investment costs and C_r are the running costs. The investment costs are calculated as:

$$C_i = C_{eq} + C_{li} + C_c + C_{la} + C_o$$

where C_{eq} are the equipment costs, C_{li} are the labour costs during the investment phase, C_c are the construction costs for the pools and the changing rooms, C_{la} are the costs for purchasing the land and C_o are other costs. Investment costs appear at the beginning of a project but can also appear in expansion phases.

The running costs for Takhini Hot Springs can be defined as:

$$C_r = C_m + C_e + C_{lr} + C_a$$

where C_m are maintenance and operation costs, C_e are electricity costs, C_{lr} are labour costs during the operation period and C_a are annuity costs. Pumping costs for the distribution of the geothermally heated water are included in the maintenance and operation costs. The annuity costs are calculated as:

$$C_a = C_i \cdot \left(1 - \frac{E_c}{E_v}\right) \cdot \frac{(1+r)^{pb} \cdot r}{(1+r)^{pb} - 1}$$

where E_c is the equity capital, E_v is the book value, r is the interest rate and pb is the payback period.

The revenue of Takhini Hot Spring stems solely from ticket sales. Currently there are 13 different tickets on offer. Three different ticket categories allow 30, 12 or 1 visit. Each category has different prices for adults, seniors, youth and children. A family pass also exists for one-time visitors. Consequently the revenue can be defined as:

$$R_n = \sum_{n=1}^N R_{an} + R_{sn} + R_{yn} + R_{cn} + R_{fn}$$

where R_n is the revenue in period n , R_a is the revenue from adult ticket sales, R_s is the revenue from senior ticket sales, R_y is the revenue from youth ticket sales, R_c is the revenue from children ticket sales and R_f is the revenue from family ticket sales. The revenues for the different ticket categories are calculated as:

$$\begin{aligned} R_a &= T_{30a} \cdot P_{30a} + T_{12a} \cdot P_{12a} + T_{1a} \cdot P_{1a} \\ R_s &= T_{30s} \cdot P_{30s} + T_{12s} \cdot P_{12s} + T_{1s} \cdot P_{1s} \\ R_y &= T_{30y} \cdot P_{30y} + T_{12y} \cdot P_{12y} + T_{1y} \cdot P_{1y} \\ R_c &= T_{30c} \cdot P_{30c} + T_{12c} \cdot P_{12c} + T_{1c} \cdot P_{1c} \\ R_f &= T_{1f} \cdot P_{1f} \end{aligned}$$

where T is the amount of tickets sold (30, 12 and 1 time only passes) and P is the price per ticket.

The profit of a time period n is calculated as:

$$P_n = \sum_{n=1}^N R_n - C_{i_n} - C_{r_n}$$

where N is the operational time of the hot springs.

The cash flow is calculable by correcting the profit for depreciation and taxes:

$$CF_n = (P_n - D_n) \cdot (1 - T_n)$$

where D_n is the depreciation in period n and T_n is the according tax rate in period n .

The periodic cash flow can now be used as an input parameter for the NPV calculation.

This leads to

Canadian Geothermal Energy Association
PO Box 1462 Station M, Calgary, Alberta, T2P 2L6, Canada
info@cangea.ca - www.cangea.ca



$$NPV = \sum_{n=1}^N \frac{CF_n}{(1+r)^n}$$

As described before, the discount factor r is to be calculated with the WACC method. As an approximate value, 0.08 is suggested.

Possible Future Developments

Takhini Hot Springs is run as a very successful business and also features possibilities for future investment. Expansion of the pool and spa area is achievable with the natural flow from the hot springs. Cascaded direct use applications could either use the outflow of the pools or fluid directly from the hot springs if they would be artificially stimulated in order to allow a higher flow rate.²⁵⁶

Case Study: Fort Liard, NWT

Introduction

The hamlet of Fort Liard lies in the Northwest Territories and is accessible by road throughout the year. In 2009, the CPI was 132.5 (Edmonton = 100) and in 2010 the Food Price Index was 142.5 (Edmonton = 100). The average personal income in 2012 was \$35,214, where 32.5% earned below \$15,000 and 22.5% earned higher than \$50,000.²⁵⁷ Main source of electricity is a diesel-powered generator, which is located within the community. Electricity is distributed by the Northwest Territories Power Corporation (NTPC) and is also used for space heating, alongside heating oil, wood and natural gas. In 2009, Borealis GeoPower attempted to develop the region's geothermal resource and construct a geothermal power plant in the community. Negotiations with NTPC failed in 2012.

Demographics

Table 193: Fort Liard demographics²⁵⁸

Classification	Hamlet	Percent of population over 15	53.8%
Population in 2012	568	Total private dwellings	159
Population in 2006	604	Land area	68.38 km ²
2006 to 2012 population change	-5.9%	Population density	8.3 / km ²
Median age	30.9		

Cost of Energy

Table 194: General service energy prices in Fort Liard²⁵⁹

	Residential use	Business use ²⁶⁰
Service Fee	\$18	\$40
Price for the first 1,000 kWh per month	29.73 ¢/kWh	51.60 ¢/kWh (+1.17¢/kWh)
Price for more than 1,000 kWh per month	60.83 ¢/kWh (+1.17¢/kWh)	51.60 ¢/kWh (+1.17¢/kWh)

Infrastructure

Table 195: Fort Liard infrastructure profile

List of Relevant Infrastructure	
Transportation Infrastructure	Tourism infrastructure
Airport	Campground
All weather access road	Motel
Communication Infrastructure	Emergency Services
Cell reception: 4G	Health Centre
High speed internet	Police Station
Landline phone service	
Business Infrastructure	Housing Infrastructure
Post Office	102 Private dwellings (owned)
Gas Services	57 Private dwellings (rented)
Grocery/hardware store	
Educational Infrastructure	Recreation Infrastructure
	Community Hall
	Arena
Grade school up to grade 12	Gymnasium
	Swimming Pool

Past Geothermal / Energy Developments

In 2009, Borealis GeoPower made contact with the Town of Fort Liard and the Acho Dene Koe (ADK), the resident First Nation, the Northwest Territories Power Corporation (NTPC) and Northwest Territories Environment and Natural Resources (NT-E&NR) in order to assess the potential interest in a geothermal power plant for the community.

After positive feedback, the Acho Dene Koe First Nation and Borealis Geopower applied for national funding to develop a geothermal power plant in the vicinity of Fort Liard. The alliance was granted funding from the National Resources Canada's Clean Energy Fund. This was followed by the foundation of a Joint Venture between Borealis Geopower and ADK, Nahendeh Investments in April 2010.

In June 2012 Borealis received the first geothermal land use permit and type A water license in the federal jurisdiction of Canada from the Mackenzie Valley Land and Water Board. The company had fully designed the plant and was ready to send the design to fabrication, expecting to generate between 10 and 30 local jobs.

The project involved the plan to generate 600 kWe from a binary power plant. Two geothermal wells, a production and an injection well at depths of 4,200 meters and 1,500 meters deep were supposed to be drilled. Cooling of the working fluid was ensured by a combined air and water based heat exchanger. The power plant was supposed to be connected to the existing power grid, which is owned and operated by the NTPC.²⁶¹

The reason why the project was never realised, is the failure to achieve a power purchase agreement with the NTPC.

Economic Assessment

For an economic assessment of the Fort Liard project the use of a NPV concept in the form of the Levelized Cost of Electricity (LCOE) is advisable. The LCOE represents the NPV of the cost of a unit of electricity over the lifetime of the power plant and is calculated as:

$$LCOE = \sum_{n=1}^N \frac{C_{i_n} + C_{r_n}}{(1+r)^n} \cdot \frac{E_n}{(1+r)^n}$$

where C_{i_n} are the investment costs, C_{r_n} are the running cost and E_n is the electricity generation in period n . The lifetime of the power plant is displayed as N and the discount rate is displayed as r . The investment costs are calculated as:

$$C_i = C_{eq} + C_{li} + C_c + C_{la} + C_d + C_o$$

where C_{eq} are the equipment costs, C_{li} are the labour costs during the investment phase, C_c are the construction costs, C_{la} are the costs for purchasing the land, C_d are the drilling costs and C_o are other costs. Investment costs appear at the beginning of a project but can also appear in expansion phases.

The running costs for Fort Liard can be defined as:

$$C_r = C_m + C_{lr} + C_t + C_a$$

where C_m are maintenance and operation costs, C_{lr} are labour costs during the operation period, C_t are transportation costs and C_a are annuit costs. The annuity costs are calculated as:

$$C_a = C_i \cdot \left(1 - \frac{E_c}{E_v}\right) \cdot \frac{(1+r)^{pb} \cdot r}{(1+r)^{pb} - 1}$$

where E_c is the equity capital, E_v is the book value, r is the interest rate and pb is the payback period. Funding from the National Resources Canada's Clean Energy Fund is regarded as equity capital.

Assuming investment costs of \$11.4 million, which occur during the first year, a capacity factor of 0.9, the ability to sell all kWh that are produced, an interest rate of 8% a project life time of 50 years and stable running costs of \$0.03/kWh, the calculatory LCOE is \$0.21/kWh.

The LCOE results are only useful for a price comparison between different electricity generating technologies and do not imply economic profitability. In order to assess the profitability of the Fort Liard binary power plant project, a classic NPV calculation is undertaken.

For the NPV calculation, the calculations for running and investment costs apply as well. The revenue of the binary power plant stems from the sale of the produced electricity. NTPC was the only customer and prices are fixed for a distinct period of time. Therefore, the revenue in a certain period n is calculated as:

$$R_n = E_n \cdot P_n$$

where E_n is the generated electricity in kWh per time period n and P_n is the achievable price per kWh and is calculated as:

$$E_n = I_c \cdot f_p$$

where I_c is the installed capacity of the power plant and f_p is its capacity factor. The profit of a time period n is calculated as:

$$B_n = \sum_{n=1}^N R_n - C_i - C_r$$

where N is the operational time of the power plant. The cash flow is calculable by correcting the profit for depreciation and taxes:

$$CF_n = (B_n - D_n) \cdot (1 - T_n)$$

where D_n is the depreciation in period n and T_n is the according tax rate in period n . This leads to

$$NPV = \sum_{n=1}^N \frac{CF_n}{(1+r)^n}$$

Assuming investment costs of \$11.4 million, which occur during the first year, stable running costs of \$0.03/kWh, a project lifetime of 50 years, a discount factor of 8%, a capacity factor of 0.9, the ability to sell all electricity that is produced, stable electricity production throughout the project lifetime and an achievable price per kWh, the NPV is \$5,474,681.

The realism of these calculations can be significantly improved by factoring in price and interest rate development as well as a detailed WACC analysis. This is not scope of this report but advised for any further economical analysis.

Project Feasibility & Future Outlook

In order to increase the economic feasibility of the project, multiple cascaded uses of the geothermal fluid were proposed in Fort Liard. The brine was supposed to be used for a local residential heating system, a spa and horticulture applications. As described in the chapter upon direct-use of geothermal heat, these applications are apt to improve the quality of life in northern communities significantly. Using the geothermal brine to heat greenhouses in the Fort Liard seems possible. This application would help to ensure food security in the community and has the potential to lower the overall high prices for vegetables and fruit.

Recent changes in the political environment and renewed interest in renewable energy development in the North indicate the possibility to reopen negotiations regarding a potential geothermal power plant in the Ft. Liard area.²⁶²

Case Study: Chena Hot Springs, Alaska

Introduction

Chena Hot Springs Resort is located in Alaska, but serves as a good example for geothermal development in northern climates. It is located roughly 91km northeast of Fairbanks and accessible by road. Chena Hot Springs has an over 100 year long history for bathing and balneology. In recent times the area is home to a resort, consisting of a spa, a greenhouse, a museum, a restaurant and a hotel.

Before the geothermal development resulted in a binary power plant, electricity at Chena Hot Springs was available through diesel generators. The cost of electricity came to approximately \$0.30/kWh (US). With the installation of geothermal binary power plants at the hot springs, the cost was reduced to roughly \$0.06/kWh (US). The Chena Hot Springs Resort used about \$1,000/day worth of diesel fuel in 2004, which has been substituted by geothermal energy.²⁶³

The hot springs were initially used for recreational bathing in the early 20th century. However, Chena Hot Springs has now evolved into a resort facility. Today, Chena Hot Springs is a resort, which is served by a geothermal binary power plant.

One of the main attractions in Chena Hot Springs include the Aurora Ice Museum, which is one of the few ice museums in the world which is open all year round. A number of services and activities are provided by Chena Hot Springs during both winter and summer to tourists such as views of the Aurora Borealis, sightseeing by helicopter, glacier tours, etc. Overall, Chena's infrastructure includes forty-four buildings on site and two greenhouses of approximately 6,000 sqft in combined size.

Geothermal Power Plant

In 2006 two 200 kW organic Rankine cycle (ROC) units were installed at Chena Hot Springs. The units use equipment from the HVAC industry in order to reduce the investment costs. The working fluid that is used is R134a. Both units can be either air-

cooled or water-cooled. Air-cooling offers significant advantages when the very low winter temperatures of interior Alaska are considered.

Quartz and Na-K-Ca geothermometry predicts maximum resource temperatures 137°C. The actual surface temperature of the fluid is 73°C. This temperature is high enough to vapourize the working fluid. The geothermal fluid is pumped through 3,000 ft of 8 inch insulated HDPE piping at 500 gpm, from a well that is located 1.2 km from the power plant. The temperature of the geothermal fluid decreases by only 1°C during the coldest months of the winter. The thermal efficiency is quoted to be 8.2%. After the binary fluid has powered the turbine it is condensed using cold water supplied through a steel pipeline, with 2,400 ft of 19 in and 300 ft of 16 in, from a well 2,700 ft away from the power plant. The 33 ft incline from the well of cool water to the plant means that no pump is required to transport 1,500 gpm of water to flow through the condensers at 5 psi. The temperature of the cold water increases by about 6°C as it passes through the condensers, before it is discharged in to Monument Creek. In the winter, the air-cooled condenser is used. ²⁶⁴

Other Geothermal Applications

The geothermal fluid is used in the pools of Chena Hot Springs for bathing and balneology. The average temperature of the geothermal outdoor pools is approximately 41°C. Additional hot tubs and the indoor swimming pool differ in temperature. Optional spa treatments are available at the resort.

The geothermal heat is also used to heat 6,000 sqft of greenhouses, which are able to produce tomatoes and lettuce year-round. These greenhouses are the only commercial scale year-round greenhouse operating in interior or northern Alaska. The initial 1000 ft² greenhouse was expanded after the resort determined that it could operate successfully to maintain an inside temperatures of almost 26°C with outside temperatures dropping down to -49°C. The produce is used in the local restaurant and is sold in the Fairbanks area.

The ice museum, which is located on site, uses an absorption chiller to keep the inside cold. It offers ice sculptures and an ice bar, and is visited by approximately 10,000 visitors each summer.

For the interested visitor, Chena Hot Spring Resort offers geothermal education tours that provide knowledge and a hands-on geothermal experience.

Economic Assessment

Financial information (cost and revenue) of Chena Hot Spring Resort is not publicly available. A full quantitative economic assessment is therefore not feasible. Nevertheless, this chapter provides a conceptual approach for the economical assessment.

An assessment should be based on the NPV method, which is explained in the beginning of this chapter.

For Chena Hot Springs, the cost portion of the cash flow calculation can be assumed as:

$$C = C_i + C_r$$

where C_i are the investment costs and C_r are the running costs. The investment costs are calculated as:

$$C_i = C_{eq} + C_{li} + C_c + C_{la} + C_o$$

where C_{eq} are the equipment costs, C_{li} are the labour costs during the investment phase, C_c are the construction costs for the different buildings and geothermal applications, C_{la} are the costs for purchasing the land and C_o are other costs. Investment costs appear at the beginning of a project but can also appear in expansion phases.

The running costs for Chena Hot Springs can be defined as:

$$C_r = C_m + C_e + C_{lr} + C_a$$

where C_m are maintenance and operation costs, C_e are back up electricity costs, C_{lr} are labour costs during the operation period and C_a are annuity costs. Pumping costs for the

distribution of the geothermally heated water are included in the maintenance and operation costs. The annuity costs are calculated as:

$$C_a = C_i \cdot \left(1 - \frac{E_c}{E_v}\right) \cdot \frac{(1+r)^{pb} \cdot r}{(1+r)^{pb} - 1}$$

where E_c is the equity capital, E_v is the book value, r is the interest rate and pb is the payback period.

The revenue of Chena Hot Springs stems from pool ticket sales, restaurant sales, accommodation, ice museum ticket sales, spa treatments and special tours. Consequently the revenue can be defined as:

$$R_n = \sum_{n=1}^N R_{pn} + R_{rn} + R_{an} + R_{in} + R_{sn} + R_{spn}$$

where R_n is the revenue in period n , R_p is the revenue from pool ticket sales, R_r is the revenue from the restaurant, R_a is the revenue from accommodation, R_i is the revenue from ice museum ticket sales, R_s is the revenue from spa treatments and R_{sp} is the revenue from special tours. The revenues for the different revenue streams are calculated as:

$$R_p = T_s \cdot P_s + T_a \cdot P_a + T_c \cdot P_c + T_f \cdot P_f + T_r \cdot P_r$$

$$R_r = M \cdot P_m + D \cdot P_d$$

$$R_a = T_{ro} \cdot P_{ro}$$

$$R_i = T_i \cdot P_i$$

$$R_s = T_{spa} \cdot P_{spa}$$

$$R_{st} = T_{st} \cdot P_{st}$$

where T_s, T_a, T_c, T_f is the number of sold pool tickets for seniors, adults, children and families, P_s, P_a, P_c, P_f are the according ticket prices. T_r and P_r is the amount and the price of swimwear rentals, M is the amount of meals served in the restaurant and P_m is the price per meal, D is the amount of drinks served in the restaurant and P_d is the price per drink, T_{ro} is the amount of rooms rented and P_{ro} is the price per room, T_i is the amount of ice museum tickets sold and P_i is the price per ticket, T_{spa} is the amount of spa treatments sold and P_{spa} is the price per treatment, and T_{st} is the amount of special tours booked and P_{st} is the price per tour.

The profit of a time period n is calculated as:

$$P_n = \sum_{n=1}^N R_n - C_{i_n} - C_{r_n}$$

where N is the operational time of the resort

The cash flow is calculable by correcting the profit for depreciation and taxes:

$$CF_n = (P_n - D_n) \cdot (1 - T_n)$$

where D_n is the depreciation in period n and T_n is the according tax rate in period n .

The periodic cash flow can now be used as an input parameter for the NPV calculation. This leads to

$$NPV = \sum_{n=1}^N \frac{CF_n}{(1+r)^n}$$

As described before, the discount factor r is to be calculated with the WACC method. As an approximate value, 0.08 is suggested.

Project Feasibility & Future Outlook

Chena Hot Springs is an operational and highly successful resort that showcases the possibilities of geothermal energy development in rural northern regions. It can be stated that some of Chena's applications and the business model can be seen as a role model for future geothermal project development in northern Canada. Chena Hot Springs proves the economic and technical feasibility of low temperature geothermal resource development and cascaded uses of geothermal energy.

Case Study: Yellowknife, NWT

Introduction

Yellowknife is the capital city and largest community of the Northwest Territories, making it the hub of commercial activity for the province. It is located on the northern shore of the Great Slave Lake, 400 km south of Arctic Circle. Yellowknife has a full time operating airport and can be accessed year round. By road it is a 1,496.6 km drive to Edmonton, AB, along the Mackenzie Highway, a 1,791.0 km drive to Calgary, AB, along the Mackenzie Highway, and a 2,377.1 km drive to Vancouver, BC, also along the Mackenzie Highway.

Electricity in Yellowknife is supplied by Northland Utilities. Hydroelectricity produced at the Snare and Bluefish hydro sites, accounts for the majority of the power generation in Yellowknife, while there is a backup diesel generator at the Jackfish plant. As of 2015, residents pay 23.72 ¢/kWh for electricity. In December 2015, the cost of heating fuel for Yellowknife is as quoted as \$0.945/l.²⁶⁵

Past Geothermal / Energy Developments

Geothermally heated fluid can be found in the tunnels located below Con Mine, a gold mine no longer in operation that could potentially be used for energy production in Yellowknife. Con Mine is located about 3.5 km from Yellowknife's city centre. Temperatures greater than 30°C have been recorded in the geothermal fluids flowing within the mine shafts beneath Yellowknife. Research by the University of British Columbia states the theoretical heating capacity to be approximately 20 MWt, which could be enough for half of Yellowknife's population. However, Vito Engineering, a Belgium firm, performed a study on the area and attested that in fact, 1.7 MWt are readily available.²⁶⁶

Canadian Geothermal Energy Association
PO Box 1462 Station M, Calgary, Alberta, T2P 2L6, Canada
info@cangea.ca - www.cangea.ca



Since the community would only require district heating for nine months of the year, it was assumed that the underground water storage would be able to recharge and reheat over the summer months.

Community outreach and geothermal awareness training was at a very limited level prior to a referendum in March 2011. One of CanGEA's primary mandates is to undertake this type of decision maker and citizen education. To date, CanGEA has performed outreach in AB, BC, ON, NT, NS and YT.

The city of Yellowknife held the aforementioned referendum in March 2011 in order to determine whether the city should invest in developing infrastructure to extract the geothermal heat from its abandoned gold mines. The residents voted against the project, (1,362 to 997). Estimated costs of \$49 million would have been needed to complete the Con Mine project.

In June 2011, the city of Yellowknife reportedly found a financial partner in the Vancouver-based company Corix Utilities, for the completion of the Con Mine geothermal project. Unfortunately, further studies indicated that the mine itself did not have the physical layout to extract the needed quantity of geothermal fluid easily. This loss of momentum eventually led to the cancellation of the project.²⁶⁷

Many city officials still support the idea to use the mining system as a geothermal resource. If the Con Mine project was realised, it would be a great example of how to utilize northern Canada's closed mines in a sustainable and unconventional way.



Geothermal Project Considerations

Yukon Geothermal Energy Report
2016

Introduction

There are many factors to consider when developing a geothermal resource. The following chapter gives an overview of the points that are recommended for consideration. This overview is not to be understood as complete. Project specific circumstances might lead to less or more factors to consider.

- Resource Identification
- Resource Rights
- Market Factors
- Resource Exploration and Characterization
- Conceptual Project Design
- Environmental Impact
- Public Acceptance
- Policy Considerations



3 MW power and heating plant in northern Iceland, source: ThinkGeoENERGY

Identification

Prior to launching any project, it is critical to determine the optimal production location. The potential for geothermal energy in the Yukon is considerable (please refer to prior chapters) and the geographic distribution is not uniform. This report provided maps that can be used as a starting point for resource identification purposes. Any project location should be chosen with care and should be in line with the project's geographic demand centres and resulting infrastructure needs. Also, infrastructure development potential, which might be limited by accessibility, terrain, climate or legislature, has to be included in the resource identification process. If limiting factors occur, a monetization of the limiting factor is required in order to adjust the profitability assessment of the project.

Resource Rights & Legislation

The Yukon Energy Strategy, which was developed by the territorial government, set the development of a geothermal policy framework as a priority in 2009.²⁶⁸ As of now, no distinct geothermal legislation or regulation exists for the Yukon. CanGEA strongly suggests and encourages the development of appropriate geothermal legislation in order to enable government responses to geothermal land tenure requests. Tenure is essential for seeking reliable and affordable financing schemes for geothermal project development. Additionally, regulations concerning the technical operations, environmental assessment, royalty schemes and decommissioning are of importance for the development of a local geothermal industry.

Legal framework for the initiation of geothermal development

The Yukon government owns almost all subsurface rights, except for those of Category A First Nations Settlement Lands and federally administered lands. There are also some interim protected lands of Indigenous Peoples, the White Water and Kaska traditional territory, to which ownership has still not yet been ascribed.

In order to obtain tenure of Yukon lands for geothermal development, the bidder would need to show suitability, meaning interest and capacity for development.

The distribution of claims could be organized by officially publishing a public notice of any claim for which interest has been claimed. If uncontested, the permit can be issued directly. Otherwise a bidding process could be initiated.

Legal framework for full development of geothermal

From an industry perspective it is important that the exploration, development and operation of geothermal project is as simple as possible. This starts with the utilization of existing regulations where it is possible and an appropriate definition of geothermal resources, which doesn't exclude hydrocarbons in the geothermal fluid as this creates an artificial and unnecessary division between geothermal resources, which are produced simultaneously with hydrocarbons (co-production) and geothermal resources without hydrocarbon presence. Furthermore a three-tiered temperature unrelated definition into direct use, power production and combined heat and power projects are recommended.

Canadian Geothermal Energy Association
PO Box 1462 Station M, Calgary, Alberta, T2P 2L6, Canada
info@cangea.ca - www.cangea.ca



On a technical level, the drilling and completion of geothermal wells can differ significantly from oil and gas wells. The technical standards for hydrocarbon production are consequently not directly applicable to geothermal development. It is strongly suggested that documents like the “Code of practice for deep geothermal wells (NZS 2403:2015) are reviewed in order to find practical and advisable regulations that apply for the geothermal industry in Canada. NZS 2403:2015 was authored by New Zealand’s geothermal industry, which has a long history of safe practice. Modifications to reflect the Yukon’s expected lower temperatures and use of HSAs should be included.

Furthermore, it is of importance to CanGEA that Pressure Stem Tests (PST’s) and flow testing to the surface are possible from any drilled well without the necessity of converting permits from exploration to production. Pressure Stem Tests (PST’s) provide important, early and necessary insight into a reservoir’s effective permeability, porosity and production response. It is a critical feature of exploration activity, which assists in matching surface facilities to subsurface capabilities. Flow testing and subsequent water analyses provide key datasets necessary for long-term reservoir and power project development.

The Yukon Environmental and Socioeconomic Assessment Board would bear the responsibility of minimizing environmental concerns. Existing general policies might need to be altered to include the unique nature of geothermal energy development. For a non-exhaustive list of environmental assessment issues can be found in the according chapter of this report (Environmental Impact of Power Plants).

CanGEA recommends a royalty holiday for a fixed period of time in order to support initial industry growth. Once the royalty free period has passed, geothermal resources should not be treated like non-renewable hydrocarbon resources. Royalties for land use, similar to other renewable resource rents, are recommended. The BC hydropower royalty regulation is suitable as an inspiration. In order to reflect the market value of the land, a use of zone land values seems reasonable. As a power-participation rent regulation, CanGEA suggests fixed payments per produced and transmitted MWh, which are independent from the plant’s capacity factor.

Some examples for other fiscal incentives include grants for drilling or research, creation of renewable energy targets, tax breaks for unsuccessful wells, feed-in tariffs, production incentives, phased royalties, and low or no fees for land access and/or permits.

Local Market

A local market analysis is necessary in order to ensure an even supply and demand balance of heat and electricity production.

A geographically close local market is of utmost importance for small-scale geothermal projects as infrastructure costs can be a significant portion of the overall project cost. If the local market is satisfied and surplus production is achievable, options to extend the market need to be sought. For example, using geothermal power to heat a greenhouse could extend the growth periods for vegetables by such a long time that the local demand cannot meet the production anymore. This can be mitigated by further processing the vegetables in order to make them easily transportable, which allows reaching different local markets.

Being a base load energy option, geothermal energy runs at relatively constant costs while ensuring a high capacity factor. This is a good condition for Power Purchase Agreements (PPA) or contracts for preferential dispatch into the electric system to be developed. PPAs define the commercial terms for the sale of electricity between suppliers and buyers.

It is important to note that renewable resources offer attractive market contributions beyond standard power and heat generation. Geothermal energy adds unprecedented environmental quality that can make it desirable for buyers. This can lead to higher achievable prices and influence the profitability assessment positively.

Uncertainty

Uncertainty can influence all stages of a geothermal development project. The degree of uncertainty varies between each individual project. Two parts of geothermal projects that can be influenced by uncertainty are economical and geophysical modelling outcomes.

This report used the basic NPV method and derived methods for economical analyses. The two main parameters of this calculation, the cash flow and the discount rate, are both prone to uncertainty. The cash flow is an aggregation of different positive and negative monetary effects, which can vary from time period to time period and from project to project. The discount rate is usually a single parameter, which is able to affect the profitability results tremendously.²⁶⁹ In this report the uncertainty was reduced by using the calculative WACC as the discount factor. Nevertheless, uncertainty concerning the use of the right discount factor exists.

Geological and geophysical models are an important part of geothermal project development as they often determine exploratory and economic success. The model outcome relies on the quality and quantity of the data input. One of the major sources of uncertainty therefore is the lack of reliable data. This report supplies a lot of new information, which is apt to reduce this type of uncertainty for certain regions of the Yukon. Furthermore, geothermal resources are evolving, which means that during the operation of a project, the reservoir response to production might change even though the production might lie well within the sustainable bandwidth.²⁷⁰ Reasons for this can be external factors (e.g. earthquakes influencing local aquifers) or production itself. Further sources of uncertainty are the characteristics of the model. It is only a representation of reality and does not include all information available.²⁷¹

In general, models can be able to produce good results that resemble reality in a lot of cases. Nevertheless it is always important to be aware to the uncertainty involved.

Resource Exploration and Characterization

In the beginning of most geothermal development projects, the resource and reservoir characteristics are not well known. In order to gain knowledge, geological, geophysical and geochemical surface and subsurface analyses are recommended. After these analyses are completed, test drilling is apt to contribute widely to enhancing the knowledge about the local reservoir and resource characteristics.²⁷²

In addition, modeling of the geothermal resource has proven to be beneficial. The idea of modeling is the theoretical simplification of processes in order to make them mathematically and/or graphically describable. Conceptual models are usually the first step in modeling geothermal systems. This is the case, as they are the quickest and easiest to produce since they only give a general graphic overview of the system. A common way to visualize a conceptual model is a cross section of the according field, showing the main geological structures and processes of the reservoir and its surrounding areas. This model should entail enough information to paint a holistic picture of the resource and helps decision makers to concentrate information in order to ensure a successful management of the resource.²⁷³

Is the resource base large and the demand high enough, more detailed modeling is the norm. Lumped-parameter-modeling and detailed numerical modeling help to quantify reservoir response forecasts and can be an integral part for long term development and optimal exploitation strategies of geothermal resources. A detailed numerical model divides a geothermal system into multiple interconnected blocks, which then get assigned individual physical properties. Creating and managing these blocks can require a considerable amount of time. The blocks are usually connected to a two dimensional surface grid, which determines the block distribution throughout the system.²⁷⁴ Due to cost and time consideration, this method is sometimes omitted and the more simple approach of lumped-parameter-modeling is used. It has been proven to successfully simulate various low temperature systems in Iceland and might be considered for use if the data amount available for the reservoir in question is small, or the time or budget are limited.²⁷⁵ The theoretical foundation of lumped parameter modeling is the concept of dividing the geothermal system into two or more individual data tanks. This contrasts the

hundreds or even thousands of modeling blocks of detailed numerical models. Usually, one block represents the production zone of the system, while the other blocks represent recharge zones. The model can either be regarded as open or closed. It is open when geothermal fluid can be exchanged with the surroundings. The properties are uniform within each block. Withdrawal from the production tank will influence all connected tanks, according to the set properties for the individual tanks and connectors.²⁷⁶ Even though, parameter uniformity seems disadvantageous, these models are able to provide important information for the decision makers.²⁷⁷

Conceptual Project Design

An integral part of developing a geothermal resource is the actual design of the necessary system. The equipment varies with the desired application and can therefore not be discussed in detail in this report.

Environmental Impact of Power Plants

The environmental impact of geothermal power depends on its application but is in general very low when compared to fossil fuel based electricity generation or heating. Various possible environmental impacts have to be discussed when geothermal resources are being developed:

- air pollution
- noise pollution
- land usage
- induced seismicity
- water usage
- disturbance of wildlife

Air pollution from geothermal power plants is on extremely low levels and stems from non-condensable gases in the geothermal fluid. Carbon dioxide and hydrogen sulphide are the most prominent ones and can appear as emissions from non-binary power plants. Binary power plants typically do not emit greenhouse gases at all. An average flashing power plant produces 27kg of CO₂ per MWh, whereas a typical coal-fired power

Canadian Geothermal Energy Association
PO Box 1462 Station M, Calgary, Alberta, T2P 2L6, Canada
info@cangea.ca - www.cangea.ca



plant produces 994kg of CO₂ per MWh. Dry steam power plants emissions are usually slightly above those of flashing power plants.²⁷⁸

Noise pollution from geothermal resource development stems mainly from construction and drilling phases of the project. These non-permanent noises are on comparable levels to other large-scale construction projects. During its operational phase a geothermal power plant produces noise on a relatively low level. Considering the usual location amidst a larger geothermal field, the noise level is typically not a source of concern for the population.

The land usage of geothermal power plants depends on the resource type, the topography of the reservoir surface area, the engineering design of the power plant, and the plant type. The power plant itself is usually built within close proximity of the wells as thermodynamic losses intensify with prolonged piping systems. The overall area of suggested power plants for the Yukon are rather small, as the rated power output rarely exceeds 1 MW (with the exception of Whitehorse). The area surrounding the wells can be used for agricultural purposes even when the plant is in operation.

Induced seismicity can occur when geothermal fluid is reinjected into the ground but is usually only a source of substantial concern when enhanced geothermal systems are involved. Enhanced geothermal systems are not suggested for the Yukon.

Water usage of geothermal power plants is on a relatively low level and is highest while drilling wells. During the operational phase, water might be used for water-cooling towers.

Wildlife can be disturbed due to noise pollution from geothermal power plants, although this impact is on a very low scale and does not pose as a foreseeable problem for the Yukon.

The topics listed are to be understood as examples. A full environmental impact assessment should be included in any geothermal project development.

Finances and Funding

It is of great importance to ensure a solid financial basis for exploration, construction, maintenance and operation of geothermal energy projects. Sources for financing include equity, debt and mezzanine capital.

Financing geothermal power projects differs from traditional renewable energy project financing as geothermal by itself is different from other renewable energy sources. Locating and accessing geothermal reservoirs is a costly and lengthy undertaking, which represents upfront costs that exist at a time of relative uncertainty concerning the project's exploratory and financial success. At the same time, geothermal represents a very reliable source for electricity generation with a high capacity factor, minimal operating costs and a comparatively long project lifetime.

For financing purposes it is common practice to divide geothermal projects into their development phases: early stage financing, late development financing and construction and operation financing.²⁷⁹

Early stage financing usually encompasses the stages of resource identification, resource evaluation and test well drilling. These stages are common within the hydrocarbon exploration industries and similar financing mechanisms are relevant for geothermal projects. Private equity funds might be a suitable partner for this stage. Another commonly used investment partner are companies that have expertise in geothermal and are heading towards an Initial Public Offering (IPO). These companies might have a diversified portfolio, which is apt to include the risk of the geothermal development phases. But not only recently listed companies can be a potential partner. Companies with a lot of natural resource exploitation expertise might be able to raise internal funds or corporate debt in order to finance the early stages of a geothermal project. In general, early stage financing requires fairly high returns on investment/equity (ROI/ROE).²⁸⁰

Canadian Geothermal Energy Association
PO Box 1462 Station M, Calgary, Alberta, T2P 2L6, Canada
info@cangea.ca - www.cangea.ca



Late development financing is largely accountable for production well drilling before the construction of the actual power plant begins. Traditionally, the main capital form that is used for financing during this period is mezzanine capital. Mezzanine capital is a hybrid between debt and equity financing and is characterized by the lender taking control of a project equity share if the company faces bankruptcy. The investor does not have recourse to other company assets but traditionally expects a higher ROI than for more secure investments.²⁸¹

During the construction and operation phases resources have traditionally been proven. Hence, the project default risk is lower than before and consequently debt-financing can become a much cheaper option.

Financing direct use geothermal projects usually requires much less upfront investment and is therefore easier. Although, generally, the same statements apply.

Public Acceptance

In order to maximize public acceptance, it is critical that the local community is engaged in the project at an early stage. Giving the local people the opportunity to work with the project developer can clarify possible differences of opinion when land ownership is concerned. It is important to give concerns appropriate consideration in order to maintain a high level of public acceptance. CanGEA can help connecting project managers with the local communities and opinion leaders.

In general, geothermal project proposals receive a widespread positive feedback from local communities and are less prone to opposition than other forms of renewable energy projects. The suspected main reason for this is the minimal environmental impact that geothermal development has in the surrounding communities.

Endnotes

Yukon Geothermal Energy Report
2016

Endnotes

¹ Matek, B. (2015) 2016 Annual U.S. & Global Geothermal Power Production Report. Geothermal Energy Association. Available Online at: <http://www.geothermalenergy.org/reports/2016/2016%20Annual%20US%20Global%20Geothermal%20Power%20Production.pdf>

² Huenges, E., & Ledru, P. (2011). *Geothermal Energy Systems: Exploration, Development, and Utilization*. John Wiley & Sons.

³ Skinner, B. J., & Murck, B. W. (2011). *Blue Planet An Introduction to Earth System Science, 3rd Edition* (3 edition). Hoboken, NJ: Wiley.

⁴ Bjorlykke, K. (2010). *Petroleum Geoscience*. Berlin, Heidelberg: Springer Berlin Heidelberg.

⁵ J.W. Tester, E. M. Drake, and M. J. Driscoll, *Sustainable Energy: Choosing Among Options*. Cambridge, MA: Mit Press, 2012.

⁶ Burke, K., & Kidd, W. S. F. (1978). Were Archean continental geothermal gradients much steeper than those of today? *Nature*, 272, 240–241.

⁷ Lund, J. W. (2001). Balneological use of thermal waters. *International Geothermal Days, Bad Urach, Germany*.

⁸ Quick, H., Michael, J., Huber, H., & Arslan, U. (2010). History of international geothermal power plants and geothermal projects in Germany. In *Proceedings World Geothermal Congress*.

⁹ Tester, J. W., & Herzog, H. J. (1990). Economic predictions for heat mining: a review and analysis of hot dry rock (HDR) geothermal energy technology.

¹⁰ Norton, D. L. (1984). Theory of hydrothermal systems. *Annual Review of Earth and Planetary Sciences*, 12, 155.

¹¹ White, D. E., Muffler, L. J. P., & Truesdell, A. H. (1971). Vapor-dominated hydrothermal systems compared with hot-water systems. *Economic Geology*, 66(1), 75–97.

¹² Gupta, H., & Sukanta, R. (2006). *Geothermal Energy: An Alternative Resource for the 21st Century* (1 edition). Amsterdam ; Boston: Elsevier Science.

¹³ Canadian GeoeXchange Coalition (2015). How GeoeXchange Systems Work. Available online at: http://www.geoeXchange.ca/en/geoeXchange_how_it_works_p49.php

¹⁴ Lund, J. W., Freeston, D. H., & Boyd, T. L. (2005). Direct application of geothermal energy: 2005 Worldwide review. *Geothermics*, 34(6), 691–727.

¹⁵ Rybach, L. (2003). Geothermal energy: sustainability and the environment. *Geothermics*, 32(4), 463–470.

¹⁶ U.S. Energy Information Administration (2015). International Energy Statistics. Available Online at: <http://www.eia.gov/cfapps/ipdbproject/iedindex3.cfm?tid=2&pid=2&aid=12&cid=ww,&syid=2008&eyid=2012&unit=BKWH>

¹⁷ Weber, J. (2015). Geothermal Trend Report 2013. IEA-GIA

¹⁸ Ibid.

¹⁹ Ibid.

²⁰ Ibid.

²¹ Ibid.

²² Ibid.

²³ DiPippo, R. (2012). *Geothermal Power Plants, Third Edition: Principles, Applications, Case Studies and Environmental Impact*. Boston: Butterworth-Heinemann.

²⁴ Ibid.

²⁵ Ibid.

²⁶ Ibid.

²⁷ J.W. Tester, E. M. Drake, and M. J. Driscoll, *Sustainable Energy: Choosing Among Options*. Cambridge, MA: Mit Press, 2012

²⁸ Geo-Heat Cente, (2005). "Combined Geothermal Heat and Power Plants," *Geo-Heat Center Quarterly Bulletin*, 26(2), (June), Oregon Institute of Technology, Klamath Falls, Oregon , 34 p.

²⁹ Lund, J. W. (2005c) "Combined Heat and Power Plant, Neustadt-Glewe, Germany," *Geo-Heat Center Quarterly Bulletin*, 26(2), (June), Oregon Institute of Technology, Klamath Falls, Oregon, pp. 31-34

³⁰ Alterra Power Corp. Power Plants. Available online at:
<http://www.alterrapower.ca/properties/Operation/default.aspx>

³¹ Blue Lagoon Ltd. About us. Available online at: <http://www.bluelagoon.com/about-us/>

³² Haustak hf. Um Okkur. Available online at: <http://haustak.is/index.php/um-haustak>

³³ Canadian Geothermal Energy Association. (2013). Geothermal Technology Roadmap: Global Best Practices Summary

³⁴ Muffler, L. J. P. (ed.) (1978). "Assessment of Geothermal Resources of the United States." U.S. Geological Survey, Circular 790, Arlington, Virginia.

³⁵ Lunis, B. C. and Lund, J. W., 1998. "Examples of Direct-Use Projects, Chapter 2", Geothermal Direct-Use Engineering and Design Guidebook, 3rd edition, Geo-Heat Center, Oregon Institute of Technology, Klamath Falls, OR., p. 7 – 25.

³⁶ Ibid.

³⁷ Ragnarsson, A. (2010). "Geothermal Development in Iceland 2005-2009." Proceedings, World Geothermal Congress 2010, Bali, Indonesia, International Geothermal Association, (CD ROM).

³⁸ Ibid.

³⁹ Lund, J. W., & Boyd, T. L. (2016). Direct utilization of geothermal energy 2015 worldwide review. *Geothermics*, 60, 66–93.

⁴⁰ Ibid.

⁴¹ Ibid.

⁴² Lund, J. W., Freeston, D. H., and Boyd, T. L. (2011). Direct Utilization of Geothermal Energy 2010 Worldwide Review, *Geothermics*, 40, Elsevier, Oxford, United Kingdom, pp. 159-180.

⁴³ Boyd, T. L. (2008). Geothermal Greenhouse Information Package, Geo-Heat Center, Oregon Institute of Technology, Klamath Falls, Oregon, 287 p.

-
- ⁴⁴ Lund, J. W., & Boyd, T. L. (2016). Direct utilization of geothermal energy 2015 worldwide review. *Geothermics*, 60, 66–93.
- ⁴⁵ Ragnarsson, Á., & others. (2014). Geothermal energy in aquaculture. *Short Course VI on Utilization of Low-and Medium-Enthalpy Geothermal Resources and Financial Aspects of Utilization, Santa Tecla, El Salvador*, 23–29.
- ⁴⁶ Lund, J. W., Freeston, D. H., and Boyd, T. L. (2011). Direct Utilization of Geothermal Energy 2010 Worldwide Review, *Geothermics*, 40, Elsevier, Oxford, United Kingdom, pp. 159-180.
- ⁴⁷ Lund, J. W., and Rangel, M. A., (1995). "Pilot Fruit Drier for the Los Azufres Geothermal Field, Mexico," *Proceedings, World Geothermal Congress 1995*, International Geothermal Association, pp. 235-2338.
- ⁴⁸ Andritsos, N., Dalampakis, P., and Kolios, N., (2003). "Use of Geothermal Energy for Tomato Drying," *Geo-Heat Center Quarterly Bulletin*, 24(1), (March), Oregon Institute of Technology, Klamath Falls, Oregon, pp. 9-13.
- ⁴⁹ Lund, J. W., and Lienau, P. J. (1994). "Onion Dehydration," *Geo-Heat Center Quarterly Bulletin*, 15(4), (July), Oregon Institute of Technology, Klamath Falls, Oregon, pp. 15-18.
- ⁵⁰ Lund, J. W. (2003) "Hot Springs Resorts in the Canadian Rockies," *Geo-Heat Quarterly Bulletin*, 24(1), (March), Oregon Institute of Technology, Klamath Falls, Oregon, pp. 17-21.
- ⁵¹ ASHRAE (1999). (American Society of Heating, Refrigeration and Air-Conditioning Engineers) 1999 HVAC Application Handbook, Chapter 48 – General Applications: Swimming Pools/Health Clubs, Atlanta, GA, pp. 48.19 - 48.20.

⁵² ASHRAE (1999). (American Society of Heating, Refrigeration and Air-Conditioning Engineers) 1999 HVAC Application Handbook, Chapter 4 – Comfort Applications: Natatoriums, Atlanta, GA, pp. 4.5 - 4.7.

⁵³ Lund, J. W., Freeston, D. H., and Boyd, T. L. (2011). Direct Utilization of Geothermal Energy 2010 Worldwide Review, *Geothermics*, 40, Elsevier, Oxford, United Kingdom, pp. 159-180.

⁵⁴ Lund, J. W., (1997)“Milk Pasteurization with Geothermal Energy”, *Geo-Heat Center Quarterly Bulletin*, 18(3), (August), Oregon Institute of Technology, Klamath Falls, Oregon, pp. 13-15.

⁵⁵ Trexler, D. T., Flynn, T., and Hendrix J. W. (1990)“Heap Leaching,” *Geo-Heat Center Quarterly Bulletin*, 12(4) (summer), Oregon Institute of Technology, Klamath Falls, Oregon, pp. 1-4.

⁵⁶ Geo-Heat Center, 2007. “Bio-Fuels from Geothermal,” *Geo-Heat Center Quarterly Bulletin*, 28(1), (March), Oregon Institute of Technology, Klamath Falls, Oregon, 18 p.

⁵⁷ Lund, J. W. (2003)“Examples of Industrial Uses of Geothermal Energy in the United States,” *Geo-Heat Center Quarterly Bulletin*, 24(3), (September), Oregon Institute of Technology, Klamath Falls, Oregon, pp. 1-6.

⁵⁸ Rafferty, K. D. (2003)“Industrial Processes and the Potential for Geothermal Applications,” *Geo-Heat Center Quarterly Bulletin*, 24(3), (September), Oregon Institute of Technology, Klamath Falls, Oregon, pp. 7-11.

⁵⁹ Boyd, T. L., and DiPippo R., (2012)“Technical Assessment of the Combined Heat and Power Plant at the Oregon Institute of Technology, Klamath Falls, Oregon,” *Transactions*, Geothermal Resources Council, 36, Davis, California, pp. 1143-1149.

⁶⁰ Culver, G. G., and Lund, J. W., (1999)“Downhole Heat Exchangers,” *Geo-Heat Center Quarterly Bulletin*, 20(3), (September), Oregon Institute of Technology, Klamath Falls, Oregon , pp. 1 – 11.

⁶¹ Lund, J. W. and Lund, T. E. (2010) “Geothermal Heating of Klamath Falls Schools”, in, Individual Space Heating Case Studies, Geo-Heat Center, Klamath Falls, Oregon, pp. 104-112.

⁶² Frimannsson, H. (1991) Hitaveita Reykjavíkur After 60 Years of Operations – Development and Benefits,” *Geo-Heat Center Quarterly Bulletin*, 13(4),(December), Oregon Institute of Technology, Klamath Falls, Oregon, pp. 1-7.

⁶³ Lund, J. W., (2005), (editor)“Hitaveita Reykjavíkur and the Nesjavellir Geothermal Co-Generation Power Plant,” *Geo-Heat Center Quarterly Bulletin*, 26(2), (June), Oregon Institute of Technology, Klamath Falls, Oregon, pp. 19-24

⁶⁴ Gunnlaugsson, E., Gislason, G., Ivarsson, G., & Kjaran, S. P. (2000). Low temperature geothermal fields utilized for district heating in Reykjavik, Iceland. In *Proceedings World Geothermal Congress* (Vol. 74).

⁶⁵ Gunnlaugsson, E. (2004). Geothermal district heating in Reykjavik, Iceland. *International Geothermal Days*, 162–169.

⁶⁶ Ragnarsson, A. (2010). “Geothermal Development in Iceland 2005-2009.” Proceedings, World Geothermal Congress 2010, Bali, Indonesia, International Geothermal Association, (CD ROM).

⁶⁷ Lund, J. W., & Boyd, T. L. (2016). Direct utilization of geothermal energy 2015 worldwide review. *Geothermics*, 60, 66–93.

-
- ⁶⁸ Boissier, F., Desplan, A. and Laplaige, P., (2010)“France Country Update,” Proceedings, World Geothermal Congress 2010, Bali Indonesia, International Geothermal Association, (CD-ROM).
- ⁶⁹ Rafferty, K. D. (2003)“The Economics of Connecting Small Buildings to Geothermal District Heating System, *Geo-Heat Center Quarterly Bulletin*, 24(1), (March), Oregon Institute of Technology, Klamath Falls, Oregon, pp. 4-8.
- ⁷⁰ Lund, J. W., & Boyd, T. L. (2016). Direct utilization of geothermal energy 2015 worldwide review. *Geothermics*, 60, 66–93.
- ⁷¹ Lund, J. W. (2000a)“Taking the Waters - Introduction to Balneology”, *Geo-Heat Center Quarterly Bulletin*, 21(3), (September), Klamath Falls, Oregon, pp. 2-5.
- ⁷² Boyd, T. L., (2003)“New Snow Melt Projects in Klamath Falls, OR,” *Geo-Heat Center Quarterly Bulletin*, 24(3), (September), Oregon Institute of Technology, Klamath Falls, Oregon, pp. 12-15.
- ⁷³ Canadian National Geothermal Databasa. Available Online at:
<http://www.cangea.ca/canadian-national-geothermal-database-and-resource-favourability-maps.html>
- ⁷⁴ Jessop, A. M., Allen, V. S., Bentkowski, W., Burgess, M., Drury, M., Judge, A. S., Taylor, A. (2005). *The Canadian geothermal data compilation*. Geological Survey of Canada.
- ⁷⁵ National Oceanic and Atmospheric Administration (2016). North America: borehole Data and Climate Reconstruction. Available online at:
<http://www.ncdc.noaa.gov/paleo/borehole/nam.html>
- ⁷⁶ Beardsmore, G. R., Rybach, L., Blackwell, D., & Baron, C. (2010). A protocol for estimating and mapping global EGS potential. *GRC Transactions*, 34, 301–312.

⁷⁷ Statistics Canada (2011). Beaver Creek Census Profile. Available online at:
<http://www12.statcan.gc.ca/census-recensement/2011/dp-pd/prof/details/page.cfm?Lang=E&Geo1=CSD&Code1=6001042&Geo2=PR&Code2=60&Data=Count&SearchText=beaver%20creek&SearchType=Begins&SearchPR=01&B1=All&Custom=&TABID=1>

⁷⁸ Statistics Canada (2009). Canadian Community Health Survey 2009

⁷⁹ Yukon Energy (2011). Rate Schedule 1260, Residential Service, Small Diesel, Non-Government. Available Online at:
https://www.yukonenergy.ca/media/site_documents/1039_1260%20Residential%20Service%20Small%20Diesel,%20Non-Government.pdf

⁸⁰ Yukon Energy (2011). Rate Schedule 1280, Residential Service, Small Diesel, Government. Available Online at:
https://www.yukonenergy.ca/media/site_documents/1043_1280%20Residential%20Service%20Small%20Diesel,%20Government.pdf

⁸¹ Yukon Energy (2011). Rate Schedule 2260, General Service, Small Diesel, Non-Government. Available Online at:
https://www.yukonenergy.ca/media/site_documents/1035_2260%20General%20Service%20Small%20Diesel,%20Non-Government.pdf

⁸² Yukon Energy (2011). Rate Schedule 2270, General Service, Small Diesel, Municipal Government. Available Online at:
https://www.yukonenergy.ca/media/site_documents/1032_2270%20General%20Service%20Small%20Diesel,%20Municipal%20Government.pdf

⁸³ Yukon Energy (2011). Rate Schedule 2280, General Service, Small Diesel, Federal & Territorial Government. Available Online at:

https://www.yukonenergy.ca/media/site_documents/1028_2280%20General%20Service%20Small%20Diesel,%20Federal%20and%20Territorial%20Government.pdf

⁸⁴ Government of Yukon Socio Economic Web Portal. (2015). Beaver Creek Residential Fuel Prices. Available Online at:

http://www.sewp.gov.yk.ca/data?regionId=YK.BC&subjectId=ECON&groupId=ECON.PRICE&dataId=YBS_RES_FUEL_PRICES&tab=subject

⁸⁵ Yukon Bureau of Statistics (2014). Yukon Energy Facts 2013. Available online at:

http://www.eco.gov.yk.ca/pdf/energy_2013.pdf

⁸⁶ Statistics Canada (2011). Burwash Landing Census Profile. Available online at:

<http://www12.statcan.gc.ca/census-recensement/2011/dp-pd/prof/details/page.cfm?Lang=E&Geo1=CSD&Code1=6001039&Geo2=PR&Code2=60&Data=Count&SearchText=burwash%20landing&SearchType=Begins&SearchPR=01&B1=All&Custom=&TABID=1>

⁸⁷ Statistics Canada (2009). Canadian Community Health Survey 2009

⁸⁸ Yukon Bureau of Statistics (2014). Yukon Energy Facts 2013. Available online at:

http://www.eco.gov.yk.ca/pdf/energy_2013.pdf

⁸⁹ Yukon Energy (2011). Rate Schedule 1260, Residential Service, Small Diesel, Non-Government. Available Online at:

https://www.yukonenergy.ca/media/site_documents/1039_1260%20Residential%20Service%20Small%20Diesel,%20Non-Government.pdf

⁹⁰ Yukon Energy (2011). Rate Schedule 1280, Residential Service, Small Diesel, Government. Available Online at:

https://www.yukonenergy.ca/media/site_documents/1043_1280%20Residential%20Service%20Small%20Diesel,%20Government.pdf

⁹¹ Yukon Energy (2011). Rate Schedule 2260, General Service, Small Diesel, Non-Government. Available Online at:
https://www.yukonenergy.ca/media/site_documents/1035_2260%20General%20Service%20Small%20Diesel,%20Non-Government.pdf

⁹² Yukon Energy (2011). Rate Schedule 2270, General Service, Small Diesel, Municipal Government. Available Online at:
https://www.yukonenergy.ca/media/site_documents/1032_2270%20General%20Service%20Small%20Diesel,%20Municipal%20Government.pdf

⁹³ Yukon Energy (2011). Rate Schedule 2280, General Service, Small Diesel, Federal & Territorial Government. Available Online at:
https://www.yukonenergy.ca/media/site_documents/1028_2280%20General%20Service%20Small%20Diesel,%20Federal%20and%20Territorial%20Government.pdf

⁹⁴ Government of Yukon Socio Economic Web Portal. (2015). Beaver Creek Residential Fuel Prices. Available Online at:
http://www.sewp.gov.yk.ca/data?regionId=YK.BL&subjectId=ECON&groupId=ECON.PRICE&dataId=YBS_RES_FUEL_PRICES&tab=subject

⁹⁵ Talarico, D. (2014). Kluane First Nation Strategic Plan. Available Online at:
<http://www.kfn.ca/documents/chief-and-council/Kluane%20First%20Nation%20Strategic%20Plan%202013-16.pdf>

⁹⁶ Minister of Indian Affairs and Northern Development. (2004). Sharing The Story, Aboriginal and Northern Energy Experiences. Available Online at:
<http://www.districtenergy.org/assets/CDEA/Case-Studies/Aboriginal-and-Northern-Energy-Experiences-3-22-04.pdf>

⁹⁷ Talarico, D. (2014). Kluane First Nation Strategic Plan. Available Online at:
<http://www.kfn.ca/documents/chief-and-council/Kluane%20First%20Nation%20Strategic%20Plan%202013-16.pdf>

⁹⁸ Wellgreen Platinum Ltd. (2015). 2015 PEA. Available online at:
<http://www.wellgreenplatinum.com/projects/wellgreen/2015-pea>

⁹⁹ Statistics Canada (2011). Carcross Census Profile. Available online at:
<http://www12.statcan.gc.ca/census-recensement/2011/dp-pd/prof/details/page.cfm?Lang=E&Geo1=CSD&Code1=6001048&Geo2=PR&Code2=60&Data=Count&SearchText=carcross&SearchType=Begins&SearchPR=01&B1=All&Custom=&TABID=1>

¹⁰⁰ Statistics Canada (2009). Canadian Community Health Survey 2009

¹⁰¹ Yukon Energy (2011). Rate Schedule 1160, Residential Service, Hydro, Non-Government. Available Online at:
https://www.yukonenergy.ca/media/site_documents/1038_1160%20Residential%20Service%20Hydro,%20Non-Government.pdf

¹⁰² Yukon Energy (2011). Rate Schedule 1180, Residential Service, Hydro, Government. Available Online at:
https://www.yukonenergy.ca/media/site_documents/1042_1180%20Residential%20Service%20Hydro,%20Government.pdf

¹⁰³ Yukon Energy (2011). Rate Schedule 2160, General Service, Hydro, Non-Government. Available Online at:
https://www.yukonenergy.ca/media/site_documents/1037_2160%20General%20Service%20Hydro,%20Non-Government.pdf

¹⁰⁴ Yukon Energy (2011). Rate Schedule 2170, General Service, Hydro, Municipal Government. Available Online at:
https://www.yukonenergy.ca/media/site_documents/1033_2170%20General%20Service%20Hydro,%20Municipal%20Government.pdf

¹⁰⁵ Yukon Energy (2011). Rate Schedule 2180, General Service, Hydro, Federal & Territorial Government. Available Online at:
https://www.yukonenergy.ca/media/site_documents/1029_2180%20General%20Service%20Hydro,%20Federal%20and%20Territorial%20Government.pdf

¹⁰⁶ Government of Yukon Socio Economic Web Portal. (2015). Beaver Creek Residential Fuel Prices. Available Online at:
http://www.sewp.gov.yk.ca/data?regionId=YK.CC&subjectId=ECON&groupId=ECON.PRICE&dataId=YBS_RES_FUEL_PRICES&tab=subject

¹⁰⁷ Statistics Canada (2011). Carmacks Census Profile. Available online at:
<http://www12.statcan.gc.ca/census-recensement/2011/dp-pd/prof/details/page.cfm?Lang=E&Geo1=CSD&Code1=6001012&Geo2=PR&Code2=60&Data=Count&SearchText=Carmacks&SearchType=Begins&SearchPR=01&B1=All&Custom=>

¹⁰⁸ Statistics Canada (2009). Canadian Community Health Survey 2009

¹⁰⁹ Yukon Government Community Services – Sports and Recreation Unit (2005). Carmacks. Available online at: <http://www.community.gov.yk.ca/pdf/carmacks.pdf>

¹¹⁰ Yukon Energy (2011). Rate Schedule 1160, Residential Service, Hydro, Non-Government. Available Online at:
https://www.yukonenergy.ca/media/site_documents/1038_1160%20Residential%20Service%20Hydro,%20Non-Government.pdf

¹¹¹ Yukon Energy (2011). Rate Schedule 1180, Residential Service, Hydro, Government. Available Online at:
https://www.yukonenergy.ca/media/site_documents/1042_1180%20Residential%20Service%20Hydro,%20Government.pdf

¹¹² Yukon Energy (2011). Rate Schedule 2160, General Service, Hydro, Non-Government. Available Online at:
https://www.yukonenergy.ca/media/site_documents/1037_2160%20General%20Service%20Hydro,%20Non-Government.pdf

¹¹³ Yukon Energy (2011). Rate Schedule 2170, General Service, Hydro, Municipal Government. Available Online at:
https://www.yukonenergy.ca/media/site_documents/1033_2170%20General%20Service%20Hydro,%20Municipal%20Government.pdf

¹¹⁴ Yukon Energy (2011). Rate Schedule 2180, General Service, Hydro, Federal & Territorial Government. Available Online at:
https://www.yukonenergy.ca/media/site_documents/1029_2180%20General%20Service%20Hydro,%20Federal%20and%20Territorial%20Government.pdf

¹¹⁵ Government of Yukon Socio Economic Web Portal. (2015). Carmacks Residential Fuel Prices. Available Online at:
http://www.sewp.gov.yk.ca/data?regionId=YK.CM&subjectId=ECON&groupId=ECON.PRICE&dataId=YBS_RES_FUEL_PRICES&tab=subject

¹¹⁶ Government of Yukon Socio Economic Web Portal. (2015). Carmacks Community Spatial Price Index. Available Online at:
http://www.sewp.gov.yk.ca/data?regionId=YK.CM&subjectId=ECON&groupId=ECON.PRICE&dataId=YBS_COMM_SPATIAL_PRICE&tab=subject

¹¹⁷ Copper North Mining Corp. (2014). Carmacks Snapshot. Available Online at:
http://www.coppernorthmining.com/s/Carmacks.asp?ReportID=489055&_Type=Carmacks

¹¹⁸ Casino Mining Corporation (2016). Proposed Mine. Available online at:
<http://casinomining.com/project/proposed-mine/>

¹¹⁹ Kaminak Gold Corporation (2014). Feasibility Study. Available online at:
http://www.kaminak.com/coffee/feasibility_study/

¹²⁰ Rockhaven Resources Ltd. (2015). Technical Report. Available online at:
http://www.rockhavenresources.com/assets/projects/2015-06-19_Klaza_NI-43-101.pdf

¹²¹ Statistics Canada (2011). Dawson Census Profile. Available online at:
<http://www12.statcan.gc.ca/census-recensement/2011/dp-pd/prof/details/page.cfm?Lang=E&Geo1=CSD&Code1=6001029&Geo2=PR&Code2=60&Data=Count&SearchText=Dawson&SearchType=Begins&SearchPR=01&B1=All&Custom=&TABID=1>

¹²² Yukon Energy (2011). Rate Schedule 1160, Residential Service, Hydro, Non-Government. Available Online at:
https://www.yukonenergy.ca/media/site_documents/1038_1160%20Residential%20Service%20Hydro,%20Non-Government.pdf

¹²³ Yukon Energy (2011). Rate Schedule 1180, Residential Service, Hydro, Government. Available Online at:
https://www.yukonenergy.ca/media/site_documents/1042_1180%20Residential%20Service%20Hydro,%20Government.pdf

¹²⁴ Yukon Energy (2011). Rate Schedule 2160, General Service, Hydro, Non-Government. Available Online at:
https://www.yukonenergy.ca/media/site_documents/1037_2160%20General%20Service%20Hydro,%20Non-Government.pdf

¹²⁵ Yukon Energy (2011). Rate Schedule 2170, General Service, Hydro, Municipal Government. Available Online at:
https://www.yukonenergy.ca/media/site_documents/1033_2170%20General%20Service%20Hydro,%20Municipal%20Government.pdf

¹²⁶ Yukon Energy (2011). Rate Schedule 2180, General Service, Hydro, Federal & Territorial Government. Available Online at:
https://www.yukonenergy.ca/media/site_documents/1029_2180%20General%20Service%20Hydro,%20Federal%20and%20Territorial%20Government.pdf

¹²⁷ Government of Yukon Socio Economic Web Portal. (2015). Dawson Residential Fuel Prices. Available Online at:
http://www.sewp.gov.yk.ca/data?regionId=YK.DW&subjectId=ECON&groupId=ECON.PRICE&dataId=YBS_RES_FUEL_PRICES&tab=subject

¹²⁸ Government of Yukon Socio Economic Web Portal. (2015). Dawson Community Spatial Price Index. Available Online at:
http://www.sewp.gov.yk.ca/data?regionId=YK.DW&subjectId=ECON&groupId=ECON.PRICE&dataId=YBS_COMM_SPATIAL_PRICE&tab=subject

¹²⁹ Yukon Government (N.D.) Brewery Creek General Information. Available Online at:
http://www.emr.gov.yk.ca/mining/brewery_creek.html

¹³⁰ Golden Predator Corp. (2015). Brewery Creek. Available online at:
<http://www.goldenpredator.com/brewery-creek-mine.html>

¹³¹ Ibid.

¹³² Statistics Canada (2011). Destruction Bay Census Profile. Available online at:
<http://www12.statcan.gc.ca/census-recensement/2011/dp-pd/prof/details/page.cfm?Lang=E&Geo1=CSD&Code1=6001049&Geo2=PR&Code2=60&Data=Count&SearchText=destruction%20bay&SearchType=Begins&SearchPR=01&B1=All&Custom=&TABID=1>

¹³³ Yukon Energy (2011). Rate Schedule 1260, Residential Service, Small Diesel, Non-Government. Available Online at:

https://www.yukonenergy.ca/media/site_documents/1039_1260%20Residential%20Service%20Small%20Diesel,%20Non-Government.pdf

¹³⁴ Yukon Energy (2011). Rate Schedule 1280, Residential Service, Small Diesel, Government. Available Online at:
https://www.yukonenergy.ca/media/site_documents/1043_1280%20Residential%20Service%20Small%20Diesel,%20Government.pdf

¹³⁵ Yukon Energy (2011). Rate Schedule 2260, General Service, Small Diesel, Non-Government. Available Online at:
https://www.yukonenergy.ca/media/site_documents/1035_2260%20General%20Service%20Small%20Diesel,%20Non-Government.pdf

¹³⁶ Yukon Energy (2011). Rate Schedule 2270, General Service, Small Diesel, Municipal Government. Available Online at:
https://www.yukonenergy.ca/media/site_documents/1032_2270%20General%20Service%20Small%20Diesel,%20Municipal%20Government.pdf

¹³⁷ Yukon Energy (2011). Rate Schedule 2280, General Service, Small Diesel, Federal & Territorial Government. Available Online at:
https://www.yukonenergy.ca/media/site_documents/1028_2280%20General%20Service%20Small%20Diesel,%20Federal%20and%20Territorial%20Government.pdf

¹³⁸ Government of Yukon Socio Economic Web Portal. (2015). Destruction Bay Residential Fuel Prices. Available Online at:
http://www.sewp.gov.yk.ca/data?regionId=YK.DB&subjectId=ECON&groupId=ECON.PRICE&dataId=YBS_RES_FUEL_PRICES&tab=subject

¹³⁹ Statistics Canada (2011). Faro Census Profile. Available online at:
<http://www12.statcan.gc.ca/census-recensement/2011/dp-pd/prof/details/page.cfm?Lang=E&Geo1=CSD&Code1=6001004&Geo2=PR&Code2=60>

[&Data=Count&SearchText=Faro&SearchType=Begins&SearchPR=01&B1=All&Custom=&TABID=1](#)

¹⁴⁰ Yukon Bureau of Statistics (2014). Yukon Energy Facts 2013. Available online at:
http://www.eco.gov.yk.ca/pdf/energy_2013.pdf

¹⁴¹ Statistics Canada (2009). Canadian Community Health Survey 2009

¹⁴² Pembina Institute (2013). Community Energy Plan – Town of Faro, YT. Available
online at: <http://faroyukon.ca/cms-assets/documents/141576-873545.farocep.11.262.pdf>

¹⁴³ Town of Faro (2016). Recreation Centre. Available online at:
<http://www.faroyukon.ca/residents-of-faro/general-info/recreation.cfm>

¹⁴⁴ Yukon Energy (2011). Rate Schedule 1160, Residential Service, Hydro, Non-
Government. Available Online at:
https://www.yukonenergy.ca/media/site_documents/1038_1160%20Residential%20Service%20Hydro,%20Non-Government.pdf

¹⁴⁵ Yukon Energy (2011). Rate Schedule 1180, Residential Service, Hydro, Government.
Available Online at:
https://www.yukonenergy.ca/media/site_documents/1042_1180%20Residential%20Service%20Hydro,%20Government.pdf

¹⁴⁶ Yukon Energy (2011). Rate Schedule 2160, General Service, Hydro, Non-
Government. Available Online at:
https://www.yukonenergy.ca/media/site_documents/1037_2160%20General%20Service%20Hydro,%20Non-Government.pdf

¹⁴⁷ Yukon Energy (2011). Rate Schedule 2170, General Service, Hydro, Municipal
Government. Available Online at:

Canadian Geothermal Energy Association
PO Box 1462 Station M, Calgary, Alberta, T2P 2L6, Canada
info@cangea.ca - www.cangea.ca



https://www.yukonenergy.ca/media/site_documents/1033_2170%20General%20Service%20Hydro,%20Municipal%20Government.pdf

¹⁴⁸ Yukon Energy (2011). Rate Schedule 2180, General Service, Hydro, Federal & Territorial Government. Available Online at:

https://www.yukonenergy.ca/media/site_documents/1029_2180%20General%20Service%20Hydro,%20Federal%20and%20Territorial%20Government.pdf

¹⁴⁹ Government of Yukon Socio Economic Web Portal. (2015). Faro Residential Fuel Prices. Available Online at:

http://www.sewp.gov.yk.ca/data?regionId=YK.FO&subjectId=ECON&groupId=ECON.PRICE&dataId=YBS_RES_FUEL_PRICES&tab=subject

¹⁵⁰ Government of Yukon Socio Economic Web Portal. (2015). Faro Community Spatial Price Index. Available Online at:

http://www.sewp.gov.yk.ca/data?regionId=YK.FO&subjectId=ECON&groupId=ECON.PRICE&dataId=YBS_COMM_SPATIAL_PRICE&tab=subject

¹⁵¹ Statistics Canada (2011). Haines Junction Census Profile. Available online at:

<http://www12.statcan.gc.ca/census-recensement/2011/dp-prof/details/page.cfm?Lang=E&Geo1=CSD&Code1=6001018&Geo2=PR&Code2=60&Data=Count&SearchText=haines%20junction&SearchType=Begins&SearchPR=01&B1=All&Custom=&TABID=1>

¹⁵² Yukon Energy (2011). Rate Schedule 1160, Residential Service, Hydro, Non-Government. Available Online at:

https://www.yukonenergy.ca/media/site_documents/1038_1160%20Residential%20Service%20Hydro,%20Non-Government.pdf

¹⁵³ Yukon Energy (2011). Rate Schedule 1180, Residential Service, Hydro, Government. Available Online at:

https://www.yukonenergy.ca/media/site_documents/1042_1180%20Residential%20Service%20Hydro,%20Government.pdf

¹⁵⁴ Yukon Energy (2011). Rate Schedule 2160, General Service, Hydro, Non-Government. Available Online at:

https://www.yukonenergy.ca/media/site_documents/1037_2160%20General%20Service%20Hydro,%20Non-Government.pdf

¹⁵⁵ Yukon Energy (2011). Rate Schedule 2170, General Service, Hydro, Municipal Government. Available Online at:

https://www.yukonenergy.ca/media/site_documents/1033_2170%20General%20Service%20Hydro,%20Municipal%20Government.pdf

¹⁵⁶ Yukon Energy (2011). Rate Schedule 2180, General Service, Hydro, Federal & Territorial Government. Available Online at:

https://www.yukonenergy.ca/media/site_documents/1029_2180%20General%20Service%20Hydro,%20Federal%20and%20Territorial%20Government.pdf

¹⁵⁷ Government of Yukon Socio Economic Web Portal. (2015). Haines Junction Residential Fuel Prices. Available Online at:

http://www.sewp.gov.yk.ca/data?regionId=YK.HJ&subjectId=ECON&groupId=ECON.PRICE&dataId=YBS_RES_FUEL_PRICES&tab=subject

¹⁵⁸ Government of Yukon Socio Economic Web Portal. (2015). Haines Junction Community Spatial Price Index. Available Online at:

http://www.sewp.gov.yk.ca/data?regionId=YK.HJ&subjectId=ECON&groupId=ECON.PRICE&dataId=YBS_COMM_SPATIAL_PRICE&tab=subject

¹⁵⁹ Village of Haines Junction. (2012). Official Community Plan, Appendix A. Available Online at: <http://www.hainesjunctionyukon.com/index.php/document-list/village-documents/53-2013-ocp/file>

¹⁶⁰ Statistics Canada (2011). Mayo Census Profile. Available online at:

<http://www12.statcan.gc.ca/census-recensement/2011/dp-pd/prof/details/page.cfm?Lang=E&Geo1=CSD&Code1=6001022&Geo2=PR&Code2=60&Data=Count&SearchText=Mayo&SearchType=Begins&SearchPR=01&B1=All&Custom=&TABID=1>

¹⁶¹ Yukon Energy (2011). Rate Schedule 1160, Residential Service, Hydro, Non-Government. Available Online at:

https://www.yukonenergy.ca/media/site_documents/1038_1160%20Residential%20Service%20Hydro,%20Non-Government.pdf

¹⁶² Yukon Energy (2011). Rate Schedule 1180, Residential Service, Hydro, Government. Available Online at:

https://www.yukonenergy.ca/media/site_documents/1042_1180%20Residential%20Service%20Hydro,%20Government.pdf

¹⁶³ Yukon Energy (2011). Rate Schedule 2160, General Service, Hydro, Non-Government. Available Online at:

https://www.yukonenergy.ca/media/site_documents/1037_2160%20General%20Service%20Hydro,%20Non-Government.pdf

¹⁶⁴ Yukon Energy (2011). Rate Schedule 2170, General Service, Hydro, Municipal Government. Available Online at:

https://www.yukonenergy.ca/media/site_documents/1033_2170%20General%20Service%20Hydro,%20Municipal%20Government.pdf

¹⁶⁵ Yukon Energy (2011). Rate Schedule 2180, General Service, Hydro, Federal & Territorial Government. Available Online at:

https://www.yukonenergy.ca/media/site_documents/1029_2180%20General%20Service%20Hydro,%20Federal%20and%20Territorial%20Government.pdf

¹⁶⁶ Government of Yukon Socio Economic Web Portal. (2015). Mayo Residential Fuel Prices. Available Online at:
http://www.sewp.gov.yk.ca/data?regionId=YK.MO&subjectId=ECON&groupId=ECON.PRICE&dataId=YBS_RES_FUEL_PRICES&tab=subject

¹⁶⁷ Government of Yukon Socio Economic Web Portal. (2015). Mayo Community Spatial Price Index. Available Online at:
http://www.sewp.gov.yk.ca/data?regionId=YK.MO&subjectId=ECON&groupId=ECON.PRICE&dataId=YBS_COMM_SPATIAL_PRICE&tab=subject

¹⁶⁸ Copper North Mining Corp. (2014). Carmacks Snapshot. Available Online at:
http://www.coppernorthmining.com/s/Carmacks.asp?ReportID=489055&_Type=Carmacks

¹⁶⁹ Alexco Resource Corporation (2016). Bellekeno Mine. Available online at:
<http://www.alexcoresource.com/s/bellekeno.asp?ReportID=511132>

¹⁷⁰ Statistics Canada (2011). Mount Lorne Census Profile. Available online at:
<http://www12.statcan.gc.ca/census-recensement/2011/dp-prod/prof/details/Page.cfm?Lang=E&Geo1=CSD&Code1=6001044&Geo2=PR&Code2=60&Data=Count&SearchText=mount%20lorne&SearchType=Begins&SearchPR=01&B1=All&Custom=>

¹⁷¹ Statistics Canada (2009). Canadian Community Health Survey 2009

¹⁷² Yukon Energy (2011). Rate Schedule 1160, Residential Service, Hydro, Non-Government. Available Online at:
https://www.yukonenergy.ca/media/site_documents/1038_1160%20Residential%20Service%20Hydro,%20Non-Government.pdf

¹⁷³ Yukon Energy (2011). Rate Schedule 1180, Residential Service, Hydro, Government. Available Online at:

https://www.yukonenergy.ca/media/site_documents/1042_1180%20Residential%20Service%20Hydro,%20Government.pdf

¹⁷⁴ Yukon Energy (2011). Rate Schedule 2160, General Service, Hydro, Non-Government. Available Online at:

https://www.yukonenergy.ca/media/site_documents/1037_2160%20General%20Service%20Hydro,%20Non-Government.pdf

¹⁷⁵ Yukon Energy (2011). Rate Schedule 2170, General Service, Hydro, Municipal Government. Available Online at:

https://www.yukonenergy.ca/media/site_documents/1033_2170%20General%20Service%20Hydro,%20Municipal%20Government.pdf

¹⁷⁶ Yukon Energy (2011). Rate Schedule 2180, General Service, Hydro, Federal & Territorial Government. Available Online at:

https://www.yukonenergy.ca/media/site_documents/1029_2180%20General%20Service%20Hydro,%20Federal%20and%20Territorial%20Government.pdf

¹⁷⁷ Statistics Canada (2011). Old Crow Census Profile. Available online at:

<http://www12.statcan.gc.ca/census-recensement/2011/dp-pd/prof/details/page.cfm?Lang=E&Geo1=CSD&Code1=6001043&Geo2=PR&Code2=60&Data=Count&SearchText=old%20crow&SearchType=Begins&SearchPR=01&B1=All&Custom=&TABID=1>

¹⁷⁸ Vuntut Gwitchin Government. (2013). Old Crow Community Plan. Available Online at:

<http://www.vgfn.ca/pdf/old%20crow%20community%20plan.pdf>

¹⁷⁹ Ronson, J. (2014). Old Crow pushes for renewable power. Yukon News. Available Online at: <http://yukon-news.com/news/old-crow-pushes-for-renewable-power/>

¹⁸⁰ Yukon Energy (2011). Rate Schedule 1460, Residential Service, Old Crow Diesel, Non-Government. Available Online at:

https://www.yukonenergy.ca/media/site_documents/1041_1460%20Residential%20Service%20Old%20Crow%20Diesel,%20Non-Government.pdf

¹⁸¹ Yukon Energy (2011). Rate Schedule 1480, Residential Service, Old Crow Diesel, Government. Available Online at:

https://www.yukonenergy.ca/media/site_documents/1045_1480%20Residential%20Service%20Old%20Crow%20Diesel,%20Government.pdf

¹⁸² Yukon Energy (2011). Rate Schedule 2460, General Service, Old Crow Diesel, Non-Government. Available Online at:

https://www.yukonenergy.ca/media/site_documents/1034_2460%20General%20Service%20Old%20Crow%20Diesel,%20Non-Government.pdf

¹⁸³ Yukon Energy (2011). Rate Schedule 2470, General Service, Old Crow Diesel, Municipal Government. Available Online at:

https://www.yukonenergy.ca/media/site_documents/1030_2470%20General%20Service%20Old%20Crow%20Diesel,%20Municipal%20Government.pdf

¹⁸⁴ Yukon Energy (2011). Rate Schedule 2480, General Service, Old Crow Diesel, Federal & Territorial Government. Available Online at:

https://www.yukonenergy.ca/media/site_documents/1026_2480%20General%20Service%20Old%20Crow%20Diesel,%20Federal%20and%20Territorial%20Government.pdf

¹⁸⁵ Government of Yukon Socio Economic Web Portal. (2015). Old Crow Community Spatial Price Index. Available Online at:

http://www.sewp.gov.yk.ca/data?regionId=YK.OC&subjectId=ECON&groupId=ECON.PRICE&dataId=YBS_COMM_SPATIAL_PRICE&tab=subject

¹⁸⁶ Statistics Canada (2011). Pelly Crossing Census Profile. Available online at:

<http://www12.statcan.gc.ca/census-recensement/2011/dp-prof/prof/details/page.cfm?Lang=E&Geo1=CSD&Code1=6001041&Geo2=PR&Code2=60>

[&Data=Count&SearchText=pelly%20crossing&SearchType=Begins&SearchPR=01&B1=All&Custom=&TABID=1](#)

¹⁸⁷ Yukon Energy (2011). Rate Schedule 1160, Residential Service, Hydro, Non-Government. Available Online at:
https://www.yukonenergy.ca/media/site_documents/1038_1160%20Residential%20Service%20Hydro,%20Non-Government.pdf

¹⁸⁸ Yukon Energy (2011). Rate Schedule 1180, Residential Service, Hydro, Government. Available Online at:
https://www.yukonenergy.ca/media/site_documents/1042_1180%20Residential%20Service%20Hydro,%20Government.pdf

¹⁸⁹ Yukon Energy (2011). Rate Schedule 2160, General Service, Hydro, Non-Government. Available Online at:
https://www.yukonenergy.ca/media/site_documents/1037_2160%20General%20Service%20Hydro,%20Non-Government.pdf

¹⁹⁰ Yukon Energy (2011). Rate Schedule 2170, General Service, Hydro, Municipal Government. Available Online at:
https://www.yukonenergy.ca/media/site_documents/1033_2170%20General%20Service%20Hydro,%20Municipal%20Government.pdf

¹⁹¹ Yukon Energy (2011). Rate Schedule 2180, General Service, Hydro, Federal & Territorial Government. Available Online at:
https://www.yukonenergy.ca/media/site_documents/1029_2180%20General%20Service%20Hydro,%20Federal%20and%20Territorial%20Government.pdf

¹⁹² Government of Yukon Socio Economic Web Portal. (2015). Pelly Crossing Residential Fuel Prices. Available Online at:
http://www.sewp.gov.yk.ca/data?regionId=YK.PC&subjectId=ECON&groupId=ECON.PRICE&dataId=YBS_RES_FUEL_PRICES&tab=subject

¹⁹³ Capstone Mining Corp. (2014). Minto Mine Key Operational Facts. Available Online at: <http://capstonemining.com/operations/minto/overview/default.aspx>

¹⁹⁴ Mercer, B., Sagman, J. (2012). Minto Phase VI Preliminary Feasibility Study Technical Report. Capstone Mining Corp. Available Online at:
http://capstonemining.com/files/doc_downloads/Technical%20Reports/PFS.pdf

¹⁹⁵ Capstone Mining Corp. (2014). Minto. Available online at:
<http://capstonemining.com/operations/minto/overview/default.aspx>

¹⁹⁶ Statistics Canada (2011). Ross River Census Profile. Available online at:
<http://www12.statcan.gc.ca/census-recensement/2011/dp-pd/prof/details/page.cfm?Lang=E&Geo1=CSD&Code1=6001037&Geo2=PR&Code2=60&Data=Count&SearchText=ross%20river&SearchType=Begins&SearchPR=01&B1=All&Custom=&TABID=1>

¹⁹⁷ Statistics Canada (2009). Canadian Community Health Survey 2009

¹⁹⁸ Yukon Government Community Services – Sports and Recreation Unit (2005). Ross River. Available online at: http://www.community.gov.yk.ca/pdf/ross_river.pdf

¹⁹⁹ Yukon Energy (2011). Rate Schedule 1160, Residential Service, Hydro, Non-Government. Available Online at:
https://www.yukonenergy.ca/media/site_documents/1038_1160%20Residential%20Service%20Hydro,%20Non-Government.pdf

²⁰⁰ Yukon Energy (2011). Rate Schedule 1180, Residential Service, Hydro, Government. Available Online at:
https://www.yukonenergy.ca/media/site_documents/1042_1180%20Residential%20Service%20Hydro,%20Government.pdf

²⁰¹ Yukon Energy (2011). Rate Schedule 2160, General Service, Hydro, Non-Government. Available Online at:
https://www.yukonenergy.ca/media/site_documents/1037_2160%20General%20Service%20Hydro,%20Non-Government.pdf

²⁰² Yukon Energy (2011). Rate Schedule 2170, General Service, Hydro, Municipal Government. Available Online at:
https://www.yukonenergy.ca/media/site_documents/1033_2170%20General%20Service%20Hydro,%20Municipal%20Government.pdf

²⁰³ Yukon Energy (2011). Rate Schedule 2180, General Service, Hydro, Federal & Territorial Government. Available Online at:
https://www.yukonenergy.ca/media/site_documents/1029_2180%20General%20Service%20Hydro,%20Federal%20and%20Territorial%20Government.pdf

²⁰⁴ Government of Yukon Socio Economic Web Portal. (2015). Ross River Residential Fuel Prices. Available Online at:
http://www.sewp.gov.yk.ca/data?regionId=YK.RR&subjectId=ECON&groupId=ECON.PRICE&dataId=YBS_RES_FUEL_PRICES&tab=subject

²⁰⁵ Government of Yukon Socio Economic Web Portal. (2015). Ross River Community Spatial Price Index. Available Online at:
http://www.sewp.gov.yk.ca/data?regionId=YK.RR&subjectId=ECON&groupId=ECON.PRICE&dataId=YBS_COMM_SPATIAL_PRICE&tab=subject

²⁰⁶ North American Tungsten Corporation Ltd. (2009). Amended Technical Report On The Macturn Property. Available online at: <http://www.natungsten.com/i/pdf/Tech-Report-Mactung.pdf>

²⁰⁷ Yukon Zinc Corp. (2014). Wolverine Mine. Available online at:
http://www.yukonzinc.com/en/operations_index.cfm

²⁰⁸ Selwyn Chihong Mining Ltd. (2015). Project Overview. Available online at:
<http://selwynchihong.com/project/>

²⁰⁹ Statistics Canada (2011). Tagish Census Profile. Available online at:
<http://www12.statcan.gc.ca/census-recensement/2011/dp-pd/prof/details/page.cfm?Lang=E&Geo1=CSD&Code1=6001036&Geo2=PR&Code2=60&Data=Count&SearchText=Tagish&SearchType=Begins&SearchPR=01&B1=All&Custom=&TABID=1>

²¹⁰ Statistics Canada (2009). Canadian Community Health Survey 2009

²¹¹ Yukon Energy (2011). Rate Schedule 1160, Residential Service, Hydro, Non-Government. Available Online at:
https://www.yukonenergy.ca/media/site_documents/1038_1160%20Residential%20Service%20Hydro,%20Non-Government.pdf

²¹² Yukon Energy (2011). Rate Schedule 1180, Residential Service, Hydro, Government. Available Online at:
https://www.yukonenergy.ca/media/site_documents/1042_1180%20Residential%20Service%20Hydro,%20Government.pdf

²¹³ Yukon Energy (2011). Rate Schedule 2160, General Service, Hydro, Non-Government. Available Online at:
https://www.yukonenergy.ca/media/site_documents/1037_2160%20General%20Service%20Hydro,%20Non-Government.pdf

²¹⁴ Yukon Energy (2011). Rate Schedule 2170, General Service, Hydro, Municipal Government. Available Online at:
https://www.yukonenergy.ca/media/site_documents/1033_2170%20General%20Service%20Hydro,%20Municipal%20Government.pdf

²¹⁵ Yukon Energy (2011). Rate Schedule 2180, General Service, Hydro, Federal & Territorial Government. Available Online at:
https://www.yukonenergy.ca/media/site_documents/1029_2180%20General%20Service%20Hydro,%20Federal%20and%20Territorial%20Government.pdf

²¹⁶ Government of Yukon Socio Economic Web Portal. (2015). Tagish Residential Fuel Prices. Available Online at:
http://www.sewp.gov.yk.ca/data?regionId=YK.TG&subjectId=ECON&groupId=ECON.PRICE&dataId=YBS_RES_FUEL_PRICES&tab=subject

²¹⁷ Statistics Canada (2011). Teslin Census Profile. Available online at:
<http://www12.statcan.gc.ca/census-recensement/2011/dp-pd/prof/details/page.cfm?Lang=E&Geo1=CSD&Code1=6001006&Geo2=PR&Code2=60&Data=Count&SearchText=teslin&SearchType=Begins&SearchPR=01&B1=All&Custom=&TABID=1>

²¹⁸ Yukon Bureau of Statistics (2014). Yukon Energy Facts 2013. Available online at:
http://www.eco.gov.yk.ca/pdf/energy_2013.pdf

²¹⁹ Statistics Canada (2009). Canadian Community Health Survey 2009

²²⁰ Yukon Energy (2011). Rate Schedule 1160, Residential Service, Hydro, Non-Government. Available Online at:
https://www.yukonenergy.ca/media/site_documents/1038_1160%20Residential%20Service%20Hydro,%20Non-Government.pdf

²²¹ Yukon Energy (2011). Rate Schedule 1180, Residential Service, Hydro, Government. Available Online at:
https://www.yukonenergy.ca/media/site_documents/1042_1180%20Residential%20Service%20Hydro,%20Government.pdf

²²² Yukon Energy (2011). Rate Schedule 2160, General Service, Hydro, Non-Government. Available Online at:
https://www.yukonenergy.ca/media/site_documents/1037_2160%20General%20Service%20Hydro,%20Non-Government.pdf

²²³ Yukon Energy (2011). Rate Schedule 2170, General Service, Hydro, Municipal Government. Available Online at:
https://www.yukonenergy.ca/media/site_documents/1033_2170%20General%20Service%20Hydro,%20Municipal%20Government.pdf

²²⁴ Yukon Energy (2011). Rate Schedule 2180, General Service, Hydro, Federal & Territorial Government. Available Online at:
https://www.yukonenergy.ca/media/site_documents/1029_2180%20General%20Service%20Hydro,%20Federal%20and%20Territorial%20Government.pdf

²²⁵ Government of Yukon Socio Economic Web Portal. (2015). Teslin Residential Fuel Prices. Available Online at:
http://www.sewp.gov.yk.ca/data?regionId=YK.TA&subjectId=ECON&groupId=ECON.PRICE&dataId=YBS_RES_FUEL_PRICES&tab=subject

²²⁶ Government of Yukon Socio Economic Web Portal. (2015). Teslin Community Spatial Price Index. Available Online at:
http://www.sewp.gov.yk.ca/data?regionId=YK.TA&subjectId=ECON&groupId=ECON.PRICE&dataId=YBS_COMM_SPATIAL_PRICE&tab=subject

²²⁷ Statistics Canada (2011). Watson Lake Census Profile. Available online at:
<http://www12.statcan.gc.ca/census-recensement/2011/dp-pd/prof/details/page.cfm?Lang=E&Geo1=CSD&Code1=6001003&Geo2=PR&Code2=60&Data=Count&SearchText=watson%20lake&SearchType=Begins&SearchPR=01&B1=All&Custom=&TABID=1>

²²⁸ Statistics Canada (2009). Canadian Community Health Survey 2009

²²⁹ Yukon Government Community Services – Sports and Recreation Unit (2005).
Watson Lake. Available online at: <http://www.community.gov.yk.ca/pdf/wl.pdf>

²³⁰ Yukon Geological Survey (2008). Yukon Mineral Property Update 2008. Available
online at:
http://miningyukon.com/Documents/Why%20Yukon/mineral_property_update_2008.pdf

²³¹ Standing Senate Committee on Energy, the Environment and Natural Resources
(2014). Powering Canada's Territories. Available online at:
<http://www.parl.gc.ca/Content/SEN/Committee/412/enev/rep/rep14jun15-e.pdf>

²³² Ibid.

²³³ Yukon Energy (2011). Rate Schedule 1360, Residential Service, Large Diesel, Non-
Government. Available Online at:
https://www.yukonenergy.ca/media/site_documents/1040_1360%20Residential%20Service%20Large%20Diesel,%20Non-Government.pdf

²³⁴ Yukon Energy (2011). Rate Schedule 1380, Residential Service, Large Diesel,
Government. Available Online at:
https://www.yukonenergy.ca/media/site_documents/1044_1380%20Residential%20Service%20Large%20diesel,%20Government.pdf

²³⁵ Yukon Energy (2011). Rate Schedule 2360, General Service, Large Diesel, Non-
Government. Available Online at:
https://www.yukonenergy.ca/media/site_documents/1036_2360%20General%20Service%20Large%20Diesel,%20Non-Government.pdf

²³⁶ Yukon Energy (2011). Rate Schedule 2370, General Service, Large Diesel, Municipal
Government. Available Online at:

https://www.yukonenergy.ca/media/site_documents/1031_2370%20General%20Service%20Large%20Diesel,%20Municipal%20Government.pdf

²³⁷ Yukon Energy (2011). Rate Schedule 2380, General Service, Large Diesel, Federal & Territorial Government. Available Online at:

https://www.yukonenergy.ca/media/site_documents/1027_2380%20General%20Service%20Large%20Diesel,%20Federal%20and%20Territorial%20Government.pdf

²³⁸ Government of Yukon Socio Economic Web Portal. (2015). Watson Lake Residential Fuel Prices. Available Online at:

http://www.sewp.gov.yk.ca/data?regionId=YK.WLR&subjectId=ECON&groupId=ECON.PRICE&dataId=YBS_RES_FUEL_PRICES&tab=subject

²³⁹ Government of Yukon Socio Economic Web Portal. (2015). Watson Lake Community Spatial Price Index. Available Online at:

http://www.sewp.gov.yk.ca/data?regionId=YK.WLR&subjectId=ECON&groupId=ECON.PRICE&dataId=YBS_COMM_SPATIAL_PRICE&tab=subject

²⁴⁰ Statistics Canada (2011). Whitehorse Census Profile. Available online at:

<http://www12.statcan.gc.ca/census-recensement/2011/dp-pd/prof/details/page.cfm?Lang=E&Geo1=CSD&Code1=6001009&Geo2=PR&Code2=60&Data=Count&SearchText=whitehorse&SearchType=Begins&SearchPR=01&B1=All&Custom=&TABID=1>

²⁴¹ EBA Engineering Consultants Ltd. (2008). Groundwater temperature and geothermal signature assessment – City of Whitehorse – Yukon. Available online at:

[http://www.energy.gov.yk.ca/pdf/geothermal_data_whitehorse\(2\).pdf](http://www.energy.gov.yk.ca/pdf/geothermal_data_whitehorse(2).pdf)

²⁴² Ibid.

²⁴³ Statistics Canada (2009). Canadian Community Health Survey 2009

²⁴⁴ CBC News (2015). NutraPonics wants to build aquaponics test facility in Yukon.

Available Online at: <http://www.cbc.ca/news/canada/north/nutraponics-wants-to-build-aquaponics-test-facility-in-yukon-1.3341733>

²⁴⁵ Yukon Energy (2011). Rate Schedule 1160, Residential Service, Hydro, Non-Government. Available Online at:

https://www.yukonenergy.ca/media/site_documents/1038_1160%20Residential%20Service%20Hydro,%20Non-Government.pdf

²⁴⁶ Yukon Energy (2011). Rate Schedule 1180, Residential Service, Hydro, Government. Available Online at:

https://www.yukonenergy.ca/media/site_documents/1042_1180%20Residential%20Service%20Hydro,%20Government.pdf

²⁴⁷ Yukon Energy (2011). Rate Schedule 2160, General Service, Hydro, Non-Government. Available Online at:

https://www.yukonenergy.ca/media/site_documents/1037_2160%20General%20Service%20Hydro,%20Non-Government.pdf

²⁴⁸ Yukon Energy (2011). Rate Schedule 2170, General Service, Hydro, Municipal Government. Available Online at:

https://www.yukonenergy.ca/media/site_documents/1033_2170%20General%20Service%20Hydro,%20Municipal%20Government.pdf

²⁴⁹ Yukon Energy (2011). Rate Schedule 2180, General Service, Hydro, Federal & Territorial Government. Available Online at:

https://www.yukonenergy.ca/media/site_documents/1029_2180%20General%20Service%20Hydro,%20Federal%20and%20Territorial%20Government.pdf

²⁵⁰ Government of Yukon Socio Economic Web Portal. (2015). Whitehorse Residential Fuel Prices. Available Online at:

http://www.sewp.gov.yk.ca/data?regionId=YK.WH&subjectId=ECON&groupId=ECON.PRICE&dataId=YBS_RES_FUEL_PRICES&tab=subject

²⁵¹ Fabozzi, F. J., Focardi, S. M., & Kolm, P. N. (2006). *Financial Modeling of the Equity Market: From CAPM to Cointegration*. Hoboken, N.J: Wiley.

²⁵² Kaplan, S. N., & Ruback, R. S. (1994). *The Valuation of Cash Flow Forecasts: An Empirical Analysis* (Working Paper No. 4724). National Bureau of Economic Research.

²⁵³ *Financial Management: Theory & Practice*. (2013) (14 edition). Australia: South-Western College Pub.

²⁵⁴ Takhini Hots Springs (2015). Takhini Hot Springs. Available online at: <http://takhinihotpools.com/>

²⁵⁵ Takhini Hot Springs (2015). Takhini Hot Pools. Available online at: <http://takhinihotpools.com/hot-pools>

²⁵⁶ Whitehorse Daily Star (2015). Data suggest complex of hot water pockets. Available online at: <http://www.whitehorsestar.com/News/data-suggest-complex-of-hot-water-pockets>

²⁵⁷ Northwest Territories – Bureau of Statistics (2015). Fort Liard Statistical Profile. Available online at: <http://www.statsnwt.ca/community-data/Profile-PDF/Fort%20Liard.pdf>

²⁵⁸ Statistics Canada (2011). Old Crow Census Profile. Available online at: <http://www12.statcan.gc.ca/census-recensement/2011/dp-pd/prof/details/page.cfm?Lang=E&Geo1=CSD&Code1=6001043&Geo2=PR&Code2=60&Data=Count&SearchText=old%20crow&SearchType=Begins&SearchPR=01&B1=All&Custom=&TABID=1>

²⁵⁹ Northwest Territories Power Company (2015). Residential Electricity Rates. Available online at: <https://www.ntpc.com/customer-service/residential-service/what-is-my-power-rate>

²⁶⁰ Yukon Energy (2011). Rate Schedule 2470, General Service, Old Crow Diesel, Municipal Government. Available Online at:
https://www.yukonenergy.ca/media/site_documents/1030_2470%20General%20Service%20Old%20Crow%20Diesel,%20Municipal%20Government.pdf

²⁶¹ Borealis GeoPower (2016). ADK First Nation/Borealis Geothermal Project Fort Liard, NWT, Canada

²⁶² Ibid.

²⁶³ Holdmann G. (2008) The Chena Hot Springs 400 kW Geothermal Power Plant: Experience Gained During The First Year Of Operation. Available online at:
http://static1.1.sqspcdn.com/static/f/386714/3483652/1246465202447/Experience+Gained.pdf?token=NQkz0DISS%2FOf9f0%2F1_m6DoMF9Rh8%3D

²⁶⁴ Ibid

²⁶⁵ Statistics Canada (2016) Gasoline and fuel oil, average retail prices by urban centre (monthly) (Yellowknife). Available online at: <http://www.statcan.gc.ca/tables-tableaux/sum-som/I01/cst01/econ152r-eng.htm>

²⁶⁶ CBC News (2012) Geothermal heat viable option for Yellowknife, says firm. Available online at: <http://www.cbc.ca/news/canada/north/geothermal-heat-viable-option-for-yellowknife-says-firm-1.1235726>

²⁶⁷ Northern News Service Online (2014) Con geothermal not feasible, says city. Available online at: http://www.nnsi.com/frames/newspapers/2014-11/nov12_14geo.html

²⁶⁸ Yukon Government (2009) Energy Strategy for Yukon. Available online at:
http://www.energy.gov.yk.ca/pdf/energy_strategy.pdf

²⁶⁹ Moyen, N., Slade, M., & Uppal, R. (1996). Valuing risk and flexibility: a comparison of methods. *Resources Policy*, 22(1), 63–74.

²⁷⁰ Franzson, H., Gunnlaugsson, E., Árnason, K., Saemundsson, K., Steingrímsson, B., & Hardarson, B. S. (2010). The Hengill geothermal system, conceptual model and thermal evolution. In *Proceedings World Geothermal Congress* (p. 9).

²⁷¹ Stachowiak, H. (2013). *Allgemeine Modelltheorie* (Softcover reprint of the original 1st ed. 1973). Wien: Springer.

²⁷² DiPippo, R. (2012). *Geothermal Power Plants, Third Edition: Principles, Applications, Case Studies and Environmental Impact*. Boston: Butterworth-Heinemann.

²⁷³ Cumming, W. (2009). Geothermal resource conceptual models using surface exploration data. In *Proceedings, Thirty-Fourth Workshop on Geothermal Reservoir Engineering, Stanford University, Stanford, California*. Citeseer.

²⁷⁴ O’Sullivan, M. J., Pruess, K., & Lippmann, M. J. (2001). State of the art of geothermal reservoir simulation. *Geothermics*, 30(4), 395–429.

²⁷⁵ G. Axelsson, G. Björnsson, and J. E. Quijano (2005). “Reliability of lumped parameter modeling of pressure changes in geothermal reservoirs,” in World Geothermal Congress 2005, Turkey

²⁷⁶ Axelsson, G. (1989). Simulation of pressure response data from geothermal reservoirs by lumped parameter models. In *Proceedings, Fourteenth Workshop on Geothermal Reservoir Engineering, Stanford University, Stanford, California*. Citeseer.

Canadian Geothermal Energy Association
PO Box 1462 Station M, Calgary, Alberta, T2P 2L6, Canada
info@cangea.ca - www.cangea.ca



²⁷⁷ Sarak, H., Onur, M., & Satman, A. (2005). Lumped-parameter models for low-temperature geothermal fields and their application. *Geothermics*, 34(6), 728–755.

²⁷⁸ DiPippo, R. (2012). *Geothermal Power Plants, Third Edition: Principles, Applications, Case Studies and Environmental Impact*. Boston: Butterworth-Heinemann

²⁷⁹ National Renewable Energy Library. Salmon, J. P., Meurice, J., Wobus, N., Stern, F., & Duaiame, M. (2011). *Guidebook to geothermal power finance*. Boulder, Colorado

²⁸⁰ Ibid.

²⁸¹ Ibid.