

A STUDY OF SUB-SEABOTTOM
PERMAFROST IN THE BEAUFORT SEA
MACKENZIE DELTA BY HYDRAULIC
DRILLING METHODS

H.A. MacAulay², A.S. Judge¹, J.A. Hunter²
V.S. Allen¹, R.M. Gagné², M. Burgess¹,
K.G. Neave² and J. Collyer¹

Geological Survey of Canada Open File
Report No. 472

Geothermal Service of Canada Internal Report No. 77-3

¹ Division of Seismology and Geothermal Studies, Earth Physics Branch
and

² Division of Resource Geophysics and Geochemistry, Geological Survey of Canada
Department of Energy, Mines and Resources

SUMMARY

During the six-week period of March 1, to April 16, 1977, twenty-two holes were drilled from the sea-ice to maximum depths of 60 m beneath the sea-bottom of the Beaufort Sea. Each of the holes, drilled with a novel low-cost hydraulic drilling technique was instrumented with several temperature sensors which were subsequently monitored as the thermal disturbance due to the jetting dissipated. Plastic casing was installed in three holes enabling seismic and radioactive logs to be run prior to installation of the temperature cables. Preliminary results show the widespread distribution of permafrost in the sea-bottom but show additionally that it is highly variable in temperature and ice-content.

A STUDY OF SUB-SEABOTTOM PERMAFROST IN THE BEAUFORT SEA-MACKENZIE DELTA BY HYDRAULIC DRILLING METHODS

INTRODUCTION

The increasing pace of development in the Beaufort Sea through the commencement of offshore drilling for hydrocarbons necessitates a corresponding increase in geotechnical research relating not only to the current problems such as emplacement of silos and wellheads and the removal and placement of aggregate for artificial island construction connected with wildcat drilling but also to the eventual placement of oil and gas pipelines to the shoreline, permanent bottom-founded hydrocarbon drilling and production platforms, construction of deep-water harbours, the dredging of shipping channels and the identification and location of shipping hazards. All such developments will require not only information on the conventional engineering and physical properties of the sediments but also information on the current distribution of ice-bonding and ice-lensing in the sediments, local sediment temperatures and thermal properties of sediments sufficient to determine the impact of various structures on those natural conditions. For long-term structures, we will need also to know the rate at which that natural regime is changing. The Federal Government is in the position of having to police such development to achieve a balance between the environmental safeguards and reasonable costs of production to best protect the Canadian people and to provide future energy resources. A scientific understanding of the natural processes active in the subsurface of the Beaufort Sea is central to this role. The work described in this report is offered as a step towards achieving these objectives.

Hydraulic water-jet drilling has been used extensively for water-well drilling in overburden in non-permafrost areas, for very shallow drilling in pile placement and to some extent for shallow drilling in areas of discontinuous permafrost (Cederstrom and Tibbits, 1961). A simple version of the technique was applied to the problem of thermistor installation in onshore permafrost by Judge et al, (1975). Further development of the technique led to the system designed to drill into the sea-bottom from the natural platform of winter ice. Judge et al, (1976) used the system to drill five holes into the sea-bottom of the

Beaufort Sea shelf to depths of up to 60 m into which thermistor cables were installed to investigate the distribution of permafrost. The current drilling programme, using a further improved drilling system, represents the first attempt to achieve high rates of production and to place plastic casing in the holes, thus permitting additional downhole geophysical observations to temperature.

SURVEY AREAS

Two areas were selected for this season's survey, (see Fig. 1), Shallow Bay, in the vicinity of a proposed gas-pipeline crossing, and north of Garry Island, where seismic velocities have indicated anomalous sea-bottom velocities (Hunter et al, 1977).

Two lines were surveyed in the Shallow Bay area, (see Fig. 2), hole-spacing was chosen to delineate the relationship of the top of permafrost and permafrost temperatures with the receding SW shoreline.

Line A was surveyed over the two drill holes of the 1976 (Judge et al, 1976) season at the entrance of the Tiktalik Channel. Two holes on this line adjacent to the 1976 holes were offset to examine lateral variations of permafrost.

Line B was positioned 4100 meters downstream from Line A where rapid coastal recession is also in evidence.

Both lines were surveyed from the present shoreline; angles were turned by sun shots and transit. Estimated survey accuracy is ± 5 m. Line A was tied into Northern Engineering survey control baseline for the pipeline corridor.

The 'Netserk' line, north of Garry Island was positioned from the I.O.L. drilling islands Adgo J-27, Netserk B-44 and Netserk F-40 (Fig. 3). Angles were turned by sun-shooting with a transit at each of the islands and chaining began at Adgo J-27. Estimated survey accuracy is ± 50 m along the line.

ITINERARY

An advance party (Neave and MacAulay) left Ottawa for the Polar Continental Shelf Project base at Tuktoyaktuk on February 28.

Equipment and supplies were assembled at Inuvik and Tuktoyaktuk March 1-3.

Deployment of equipment to Shallow Bay by road began March 4.

Main party (Hunter, Judge, Collyer, Allen, Gagné, Burgess) arrived at Tuk March 5.

Drilling deployed and surveying done in Shallow Bay by March 13.

Drilling, logging and installation completed in Shallow Bay, March 28. (12 holes).

Camp moved to Netserk line by aircraft, March 29 - April 4.

Drilling and thermistor cable installation, April 5 - April 9. (10 holes).

Camp moved back to Tuk and packing up completed, April 15.

Main party returned to Ottawa, April 16. Judge and Burgess remained to monitor installations.

Monitoring and site clean-up completed, April 30.

The Shallow Bay camp was deployed by truck using available ice-roads and was re-supplied by air from Tuk (PCSP Bell 206).

By March 28, all ice-roads in the area were blown in so the camp was moved out by a Single Otter aircraft (casual charter). Because the sea ice along the Netserk line was too rough for landing, the camp was flown to a prepared strip at I.O.L. artificial island site Adgo J-27. From there the equipment was moved by Bell 206 (slinging), snowmobile and sled along the Netserk line. Two camps were set up, one at each of the Netserk drilling islands. On completion of the Netserk line, both camps were moved back to Adgo J-27 by skidoo and sled and from there to Tuk by Twin-Otter aircraft (casual charter).

Air temperatures in the early weeks of the program ranged between -30° and -46°C , but moderated to -15°C towards the latter part of April. Blowing snow and white-outs caused 6 non-flying days, however, since aircraft were not integral to the daily drilling operation only 2 days total delay resulted (during camp moves). Ice conditions limited the seaward extension of the Netserk line as the shear zone (edge of shorefast ice) was found to be unusually near the shoreline - approximately following

the 10 m bathymetric contour. Rough ice was encountered between the two Netserk drilling islands.

DESCRIPTION OF DRILLING EQUIPMENT

Mark 3 Wajax fire pump, 300 p.s.i. shut-off.

Wye valve 1 1/2 inch I.D.

Pressure gauge 0-400 p.s.i.

Longear B 25609 water swivel.

Light weight aluminum tripod, 13 ft (legs in two sections) complete with hoisting sheave and hand winch.

10 foot, 2 inch I.D. suction hose with foot valve.

10 foot, 1 1/2 inch I.D. discharge hose (pump tent to drill tent).

5 foot, 1 1/2 inch I.D. by-pass hose.

15 foot, 1 inch I.D. swivel hose.

L-6 Hurritent (pump shelter).

L-8 Hurritent (drilling shelter) with a tapered rectangular sock which velcros to a roof opening and accommodates that part of the tripod which extends above the roof line. These tents are manufactured by Warner Shelters of Winnipeg.

One 35000 B.T.U. Coleman oil stove to heat the drill shelter.

One General 51 power head with 10" dia. flighted ice cutter and 10" dia. flighted extensions.

Most of the above equipment was available from E.M.R.'s field store.

DRILLING PROCEDURE

At each site two 10 inch diameter holes were drilled through the ice, spaced about 12 feet apart. The pump and drill tents were positioned over these holes and the tripod and stove were installed in the drill tent. To guard against icing, no start-up was attempted until unit, hoses and other accessories were brought to temperatures well above freezing. When warm, the pump unit was removed to the unheated pump tent and all hoses

and accessories quickly connected. The pump was then primed and started with the discharge by-passed into drill hole. After the drill pipe was lowered to the sea floor the swivel was connected, the Wye valve was switched from by-pass to the swivel and jetting (or washing) commenced, adding the 1 inch drill-pipe as required. Slow rotation of the pipe string seems to increase the penetration rate through most material, although if this is not always the case the person doing the rotating may at least experience some sense of achievement.

When jetting through unfrozen material, washed samples are usually obtained from return flow up the pipe immediately after the swivel has been disconnected to add a further length of pipe. This return flow is thought to be due to overpressuring of the formation. If the return flow is not interrupted the pipe string may fill with washed material and circulation may be lost. By sacrificing a large sample this problem can be eliminated by stopping the return flow while a new connection is being made. This was done by one crew member placing his foot over the open pipe. Various bit and jet configurations were tried with no perceptible advantage over the normal open pipe end. For holes drilled to 200 feet pumping pressures ranged from 75 to 225 p.s.i.

During drilling the time taken for each section, or half-section for slow drilling, to advance past a set mark is noted as are comments on the "feel" of the drilling e.g. bouncing of the pipe. The individual drill logs for each hole are given in Appendix B and the drilling rates plotted in Appendix A. A combination of the sample appearance and the drilling information is used to construct the lithological logs shown in Appendix A and summarised as simplified cross-sections in Figs 4 to 6.

CASING PROCEDURE

For thermistor cable installation only the one inch I.D. jetting pipe was left in the hole and served as the casing. To ensure that the pipe string was clean throughout, pumping was stopped and the pipe pushed firmly into the bottom of the hole at the desired total depth. Where geophysical logs were run, two inch I.D. P.V.C. Schedule 40 plastic casing was installed. The P.V.C. casing was installed over the one-inch drill pipe which acted as a casing guide, and the 10 foot sections were connected with slip-on couplings cemented with quick-dry P.V.C. cement. The casing was hand-forced to refusal usually short of the total depth drilled and the one inch pipe pulled. After the logs were run, a thermistor cable was installed.

Dom-X ABS Pumpline drop tube, (2" x 10' threaded sections) later became available but was not used. It is anticipated that this casing could be connected to the pump and washed down over the iron pipe with low pressures down to the total depth drilled.

LOGGING PROCEDURES

The three drill holes which had been successfully cased were logged with seismic uphole shooting and radioactive tools while the heated drilling tent was still available for shelter. For seismic measurements, blasting caps were exploded under the ice in a hole offset 15 feet from the drill hole. Arrival times were recorded on a Nimbus seismograph with stacking capabilities. At each recording station, the three-component geophone was locked to the side of the hole by an air bladder inflated from a battery-operated pump at the surface. For the radioactive logging: a density log (gamma-gamma), a porosity log (neutron), and a natural gamma log; stations at two foot intervals were read to give effectively continuous coverage of the hole.

TEMPERATURE MEASUREMENTS

Upon completion, multithermistor cables were installed in 21 of the drillholes, 12 on the Shallow Bay and 9 on the Netserk line. The cables, a total of 36 which were used, were manufactured prior to the commencement of the project by MacGregor Electronics Ltd., of Carleton Place following construction specifications described by Judge (1973) using YSI 44033 epoxy-coated thermistor beads. Two thermistor configurations were specified; a 100 foot cable with 12 sensors designed for use immediately below the sea-bottom with closer sensor spacing in the upper portion and a 200 foot cable consisting of 100 feet of 10 evenly spaced sensors and 100 feet of blank cable. Deep 200 foot holes were instrumented with two cables strapped together, one above the other, whereas shorter holes were instrumented with 100 foot or 200 foot cables depending on the total depth reached. Spare cable was simply coiled at the surface. Installation was quite straightforward. Upon completion of the hole a 2 foot long, 0.5 inch diameter steel weight was strapped to the end of the cable and the cable lowered hand-over-hand into the casing until either the weight touched the bottom of the hole or all of the sensors were in the hole. The number of sensors in the hole and the depth to the first were noted so that the depth distribution of the temperature measurements was known. The thermistor resistance of each sensor in every cable was measured initially at daily intervals, using a high precision

portable Wheatstone Bridge similar to that described by Judge (1973), and then at progressively longer intervals for periods of up to 6 weeks. During that period, only 3 out of a total of 370 individual sensors failed; however, 4 complete cables on the outer part of the Netserk line failed completely after a major storm from the northwest which presumably moved the sea-ice sufficiently to break each of the cables at the sea-floor. Thermistor resistance was converted to temperature after a small correction for cable resistance using computer-prepared calibration tables. The resulting temperature curves showing the variation with both temperature and time are shown in Appendix A. Variations with time, except near and above the sediment-water interface, are largely due to the dissipation of the thermal disturbance caused by the jetting process itself. This rate of change with time can, however, reveal much information on lithology and ice-content. Once the holes have returned to the natural undisturbed temperatures or sufficient data has been accumulated to predict those temperatures, isothermal sections can be drawn such as those shown in Figs. 7 to 9. Such sections show the spatial variation of temperature and hence the present natural permafrost distribution.

BIBLIOGRAPHY

- Cederstrom, D.J. and G.C. Tibbits 1961 Jet drilling in the Fairbanks Area, Alaska. U.S.G.S. Water Supply Paper 1539-B.
- Hunter, J.A.M., H.A. MacAulay, K.G. Neave and G.D. Hobson 1977 Seismic mapping of sub-seabottom permafrost in the Beaufort Sea: Recent interpretations presented at Geol. Assoc. Can. Ann. Meet., Vancouver (G.A.C. Abstracts 2, p. 26, 1977).
- Judge, A.S., J.A. Hunter, R.L. Good, J. Cowan and G. Robb 1975 Thermistor cable installation in permafrost materials with a water-jet drilling method: Geol. Surv. Can. Paper 76-1A, p. 479-480.
- Judge, A.S., H.A. MacAulay and J.A. Hunter 1976 An application of hydraulic jet drilling techniques to mapping of sub-seabottom permafrost: Geol. Surv. Can. Paper 76-1C, p. 75-82.
- Judge, A.S. 1973 Thermal regime of the Mackenzie Valley Environmental-Social Committee Northern Pipeline. Report 73-38. D.I.N.A.

PROJECT COSTS - SPRING PROGRAMME

Logistics Support

Location Costs	\$ 6,000
Ottawa to Tuktoyaktuk (8 persons)	
Aircraft Support - fixed wing	8,500
- helicopter	24,000
Expenses in transit	<u>800</u>
	\$39,300

Drilling Programme

3000 ft. of 1" i.d. water-pipe	\$ 4,000
1,000 ft. of plastic casing	1,800
36 multithermistor cables	10,000
Incidental equipment purchases	2,000
Food for drill-camp	3,600
Fuel for camp and drill	<u>850</u>
	\$22,250
Total	\$61,550

During the period of 1 March to 16 April a total of 22 holes were drilled and monitored at a cost, excluding salaries, of \$62,000. Excluding the cost of the logistics support the cost of each hole including the temperature installation was \$1,000 per hole exclusive of salaries. Inclusion of the latter increases the per hole cost to \$1,300. A total of 2,950 ft. of hole was drilled at a cost of about \$8 per ft. exclusive of salaries or \$10 per ft. when salaries are included. If logistics support is included the cost of drilling and monitoring the sites rises to \$23 per ft.

Acknowledgements

This project could not have been conducted without very generous logistic support from the Polar Continental Shelf Project and partial funding from the Oil and Mineral Division, Department of Indian and Northern Affairs. To both of these groups we offer our grateful thanks for their confidence in us. Very many individuals from government and industry assisted in various phases of this project and we offer our thanks to them also. No list would be complete without thanking Martin Smith of D.I.N.A. in Inuvik for his continued belief in and support of our programmes.

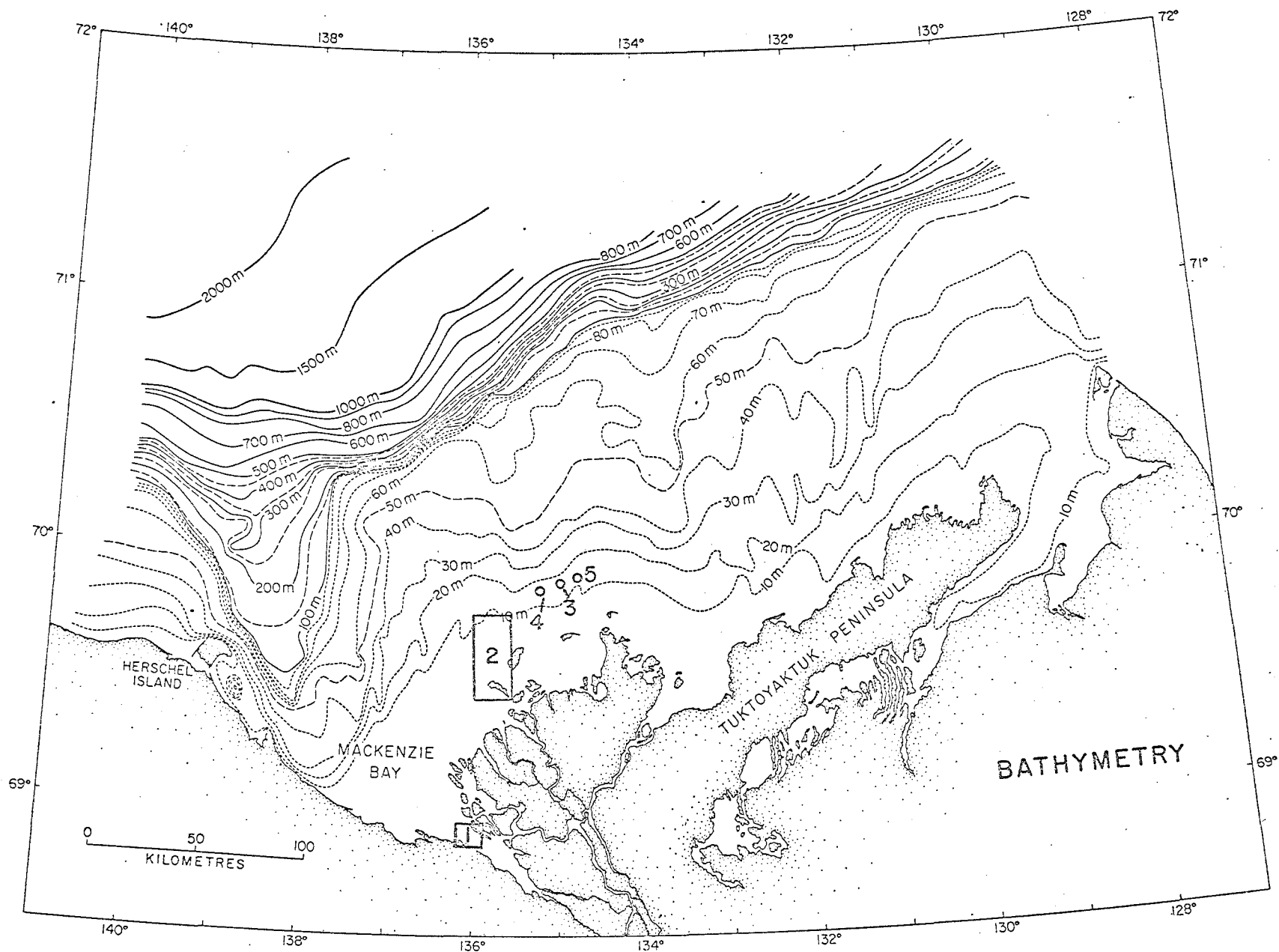

1 - SHALLOW BAY AREA 2 - NETSERK AREA

FIG. 1

3, 4, 5 - 1976 TEST HOLES

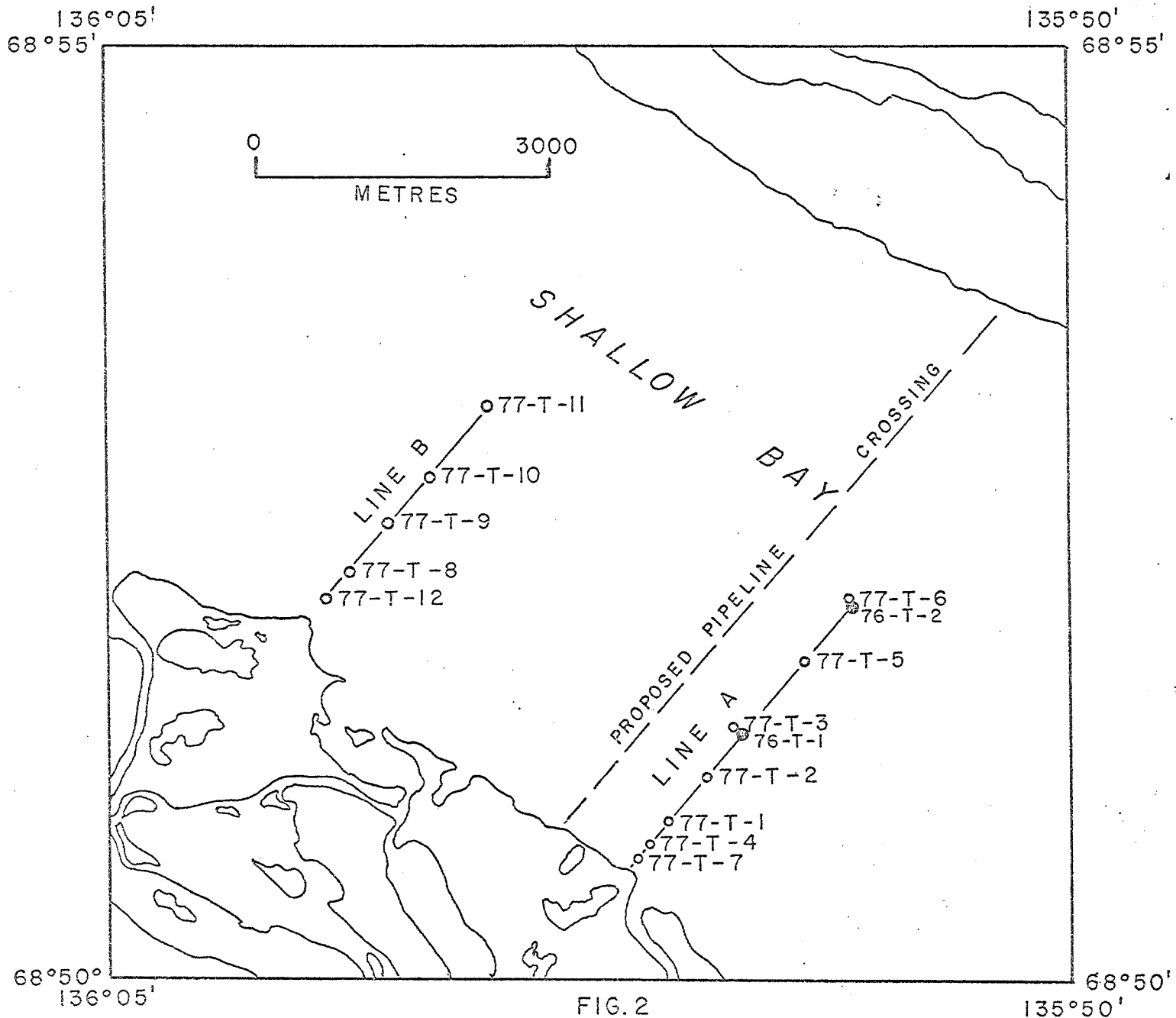

FIG. 2

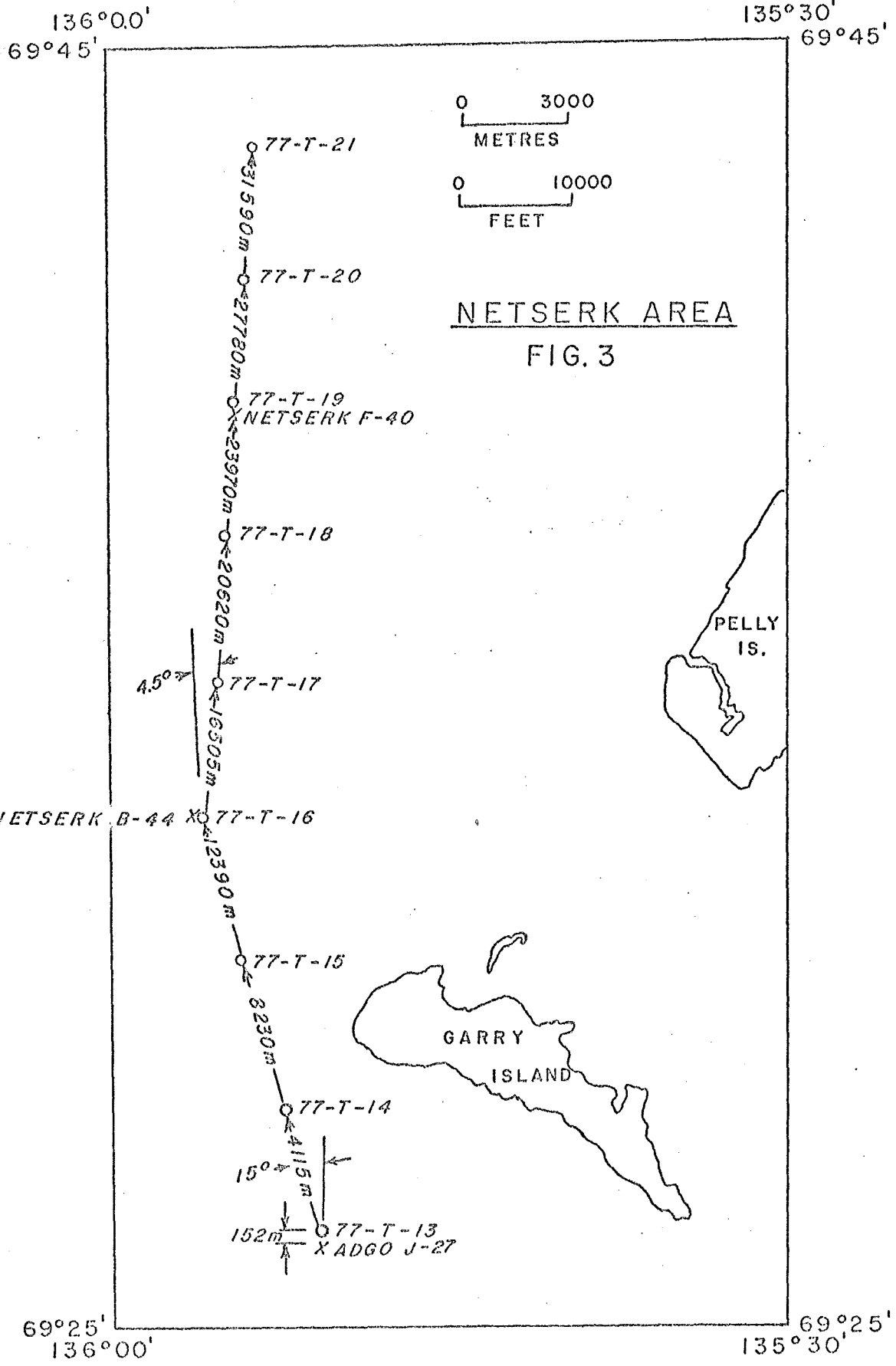
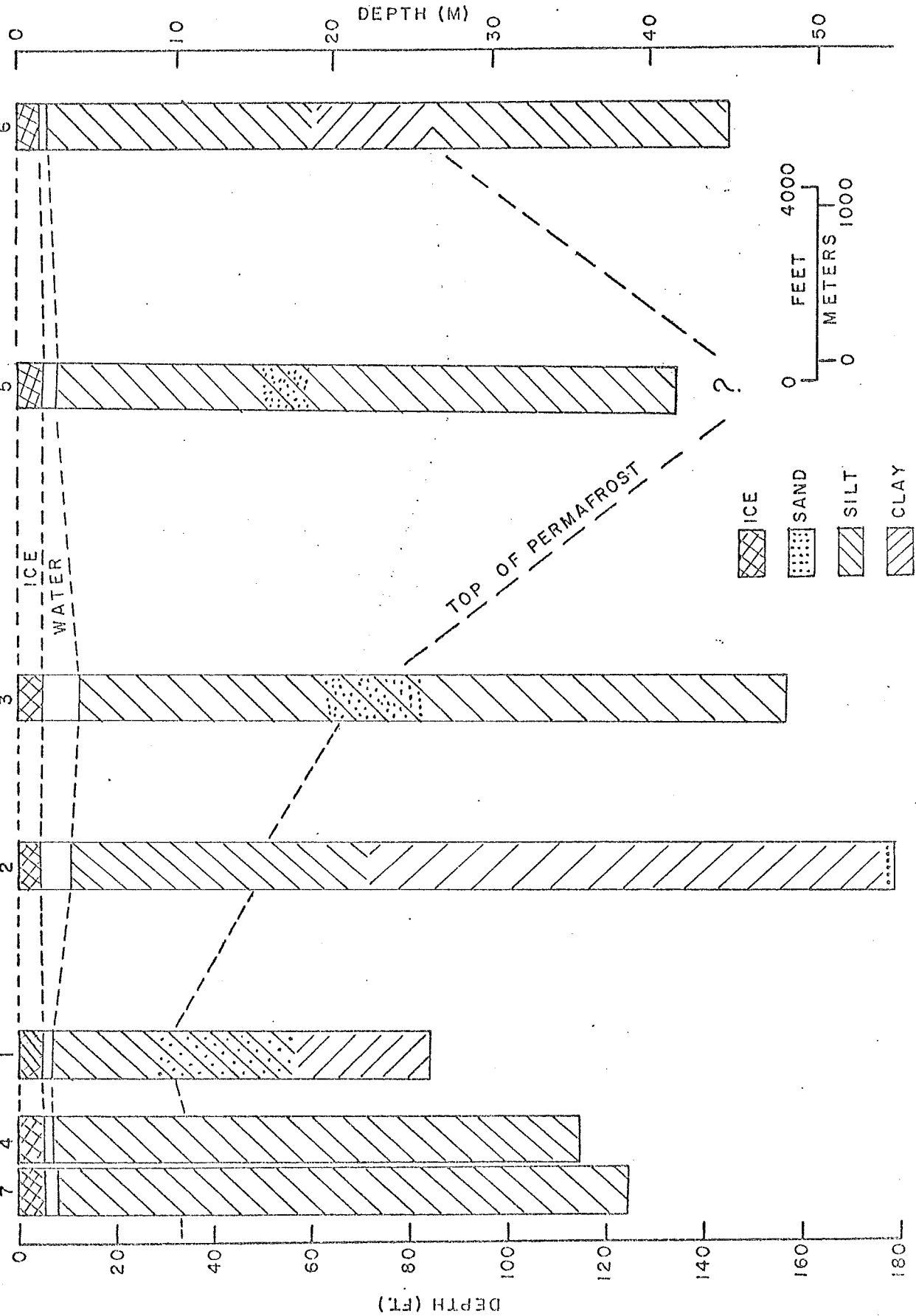

FIG. 4
LINE A

SHALLOW BAY AREA



SHALLOW BAY AREA

FIG. 5
LINE B

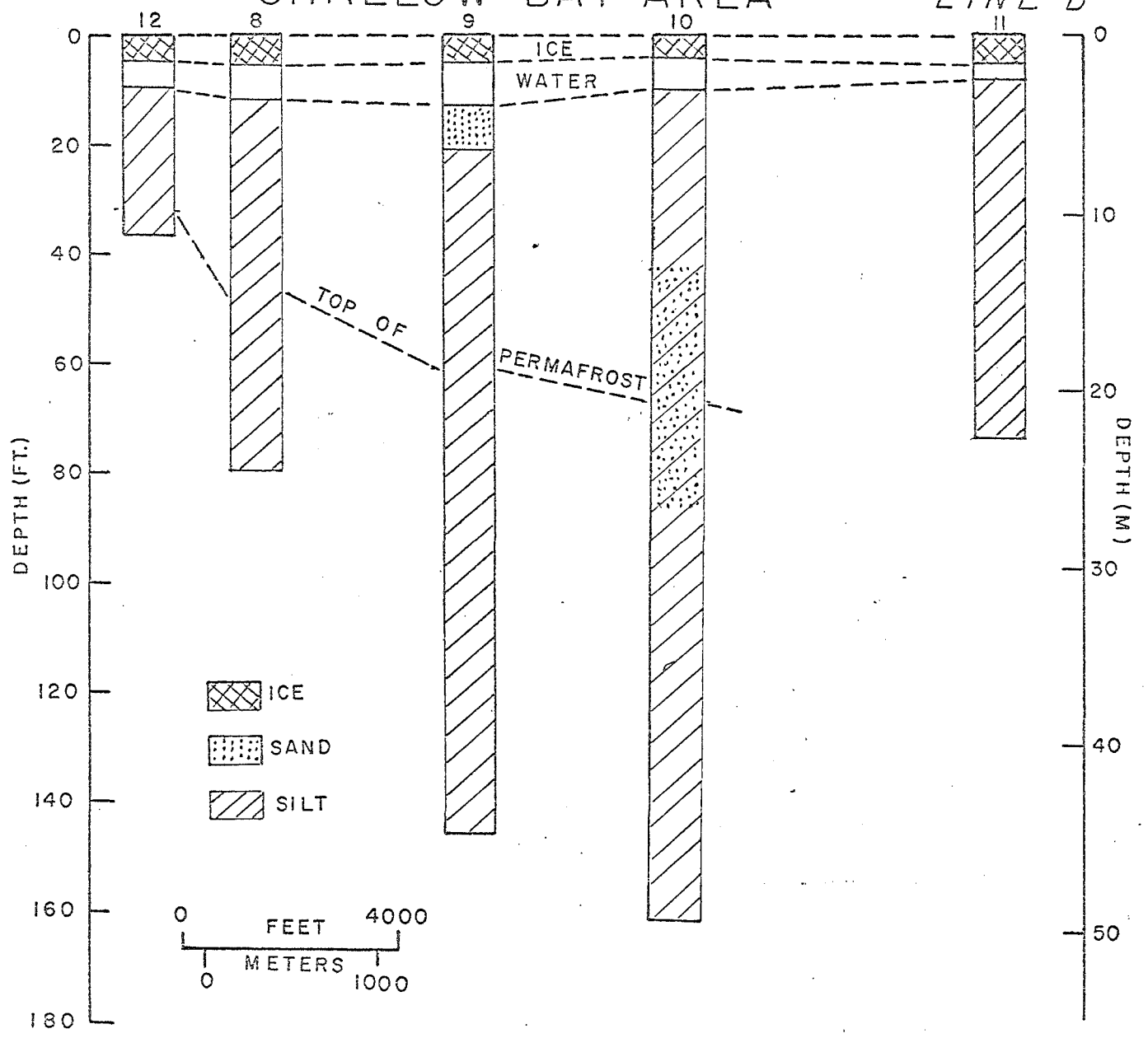

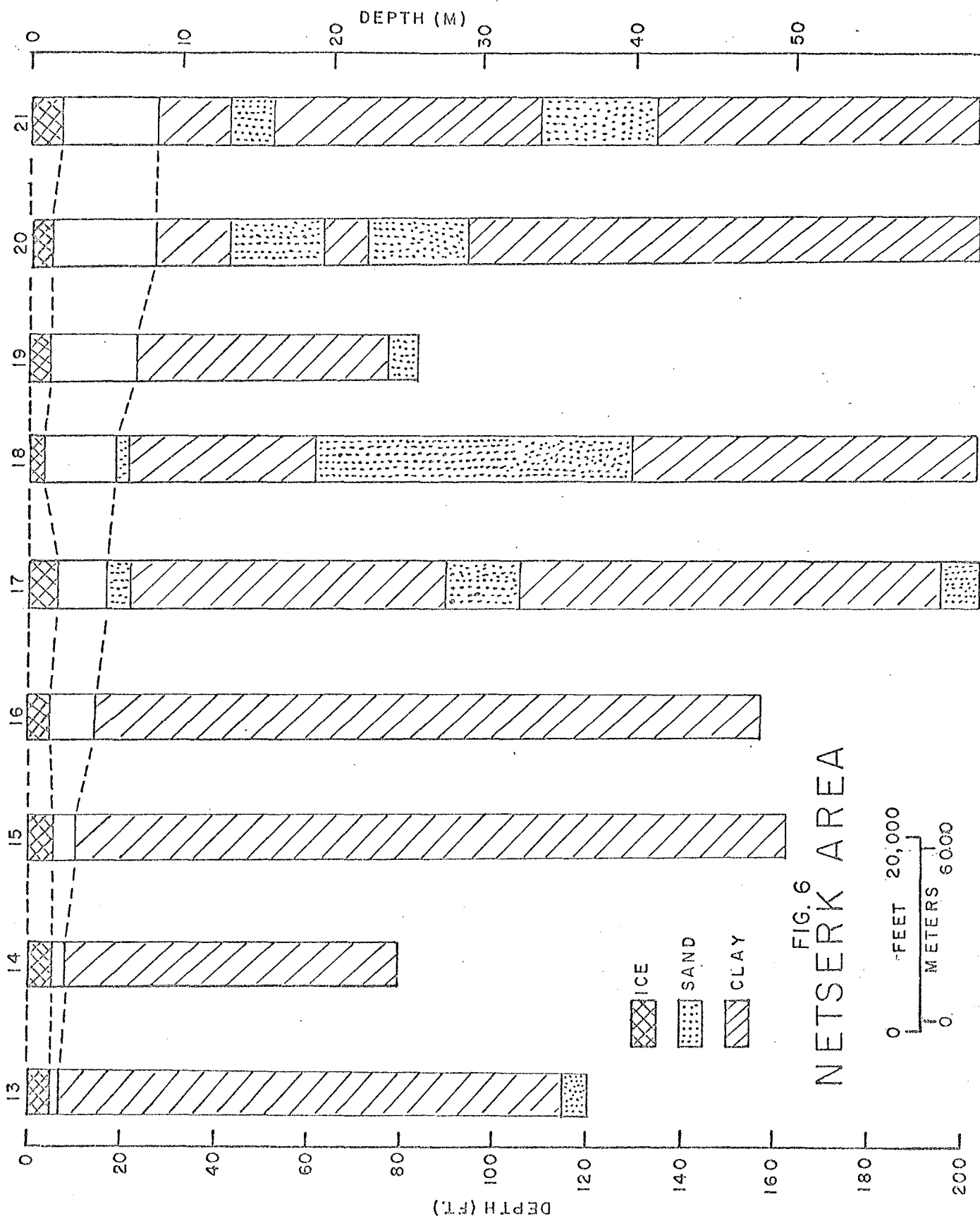
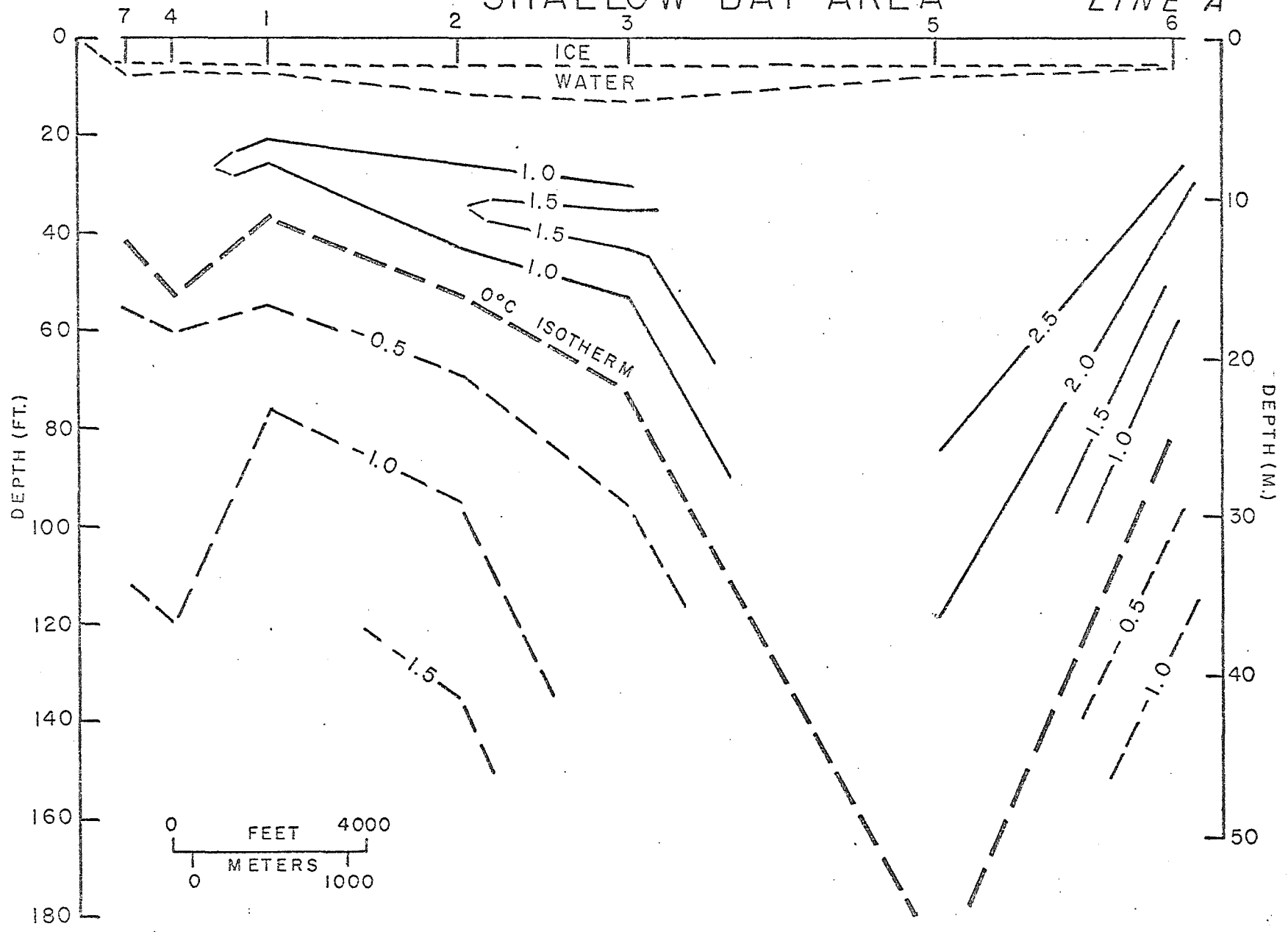

FIG. 6
NETSERK AREA

0 FEET 20,000
0 METERS 6,000

SHALLOW BAY AREA

FIG. 7
LINE A



0 FEET 4000
0 METERS 1000

FIG. 8
LINE B

SHALLOW BAY AREA

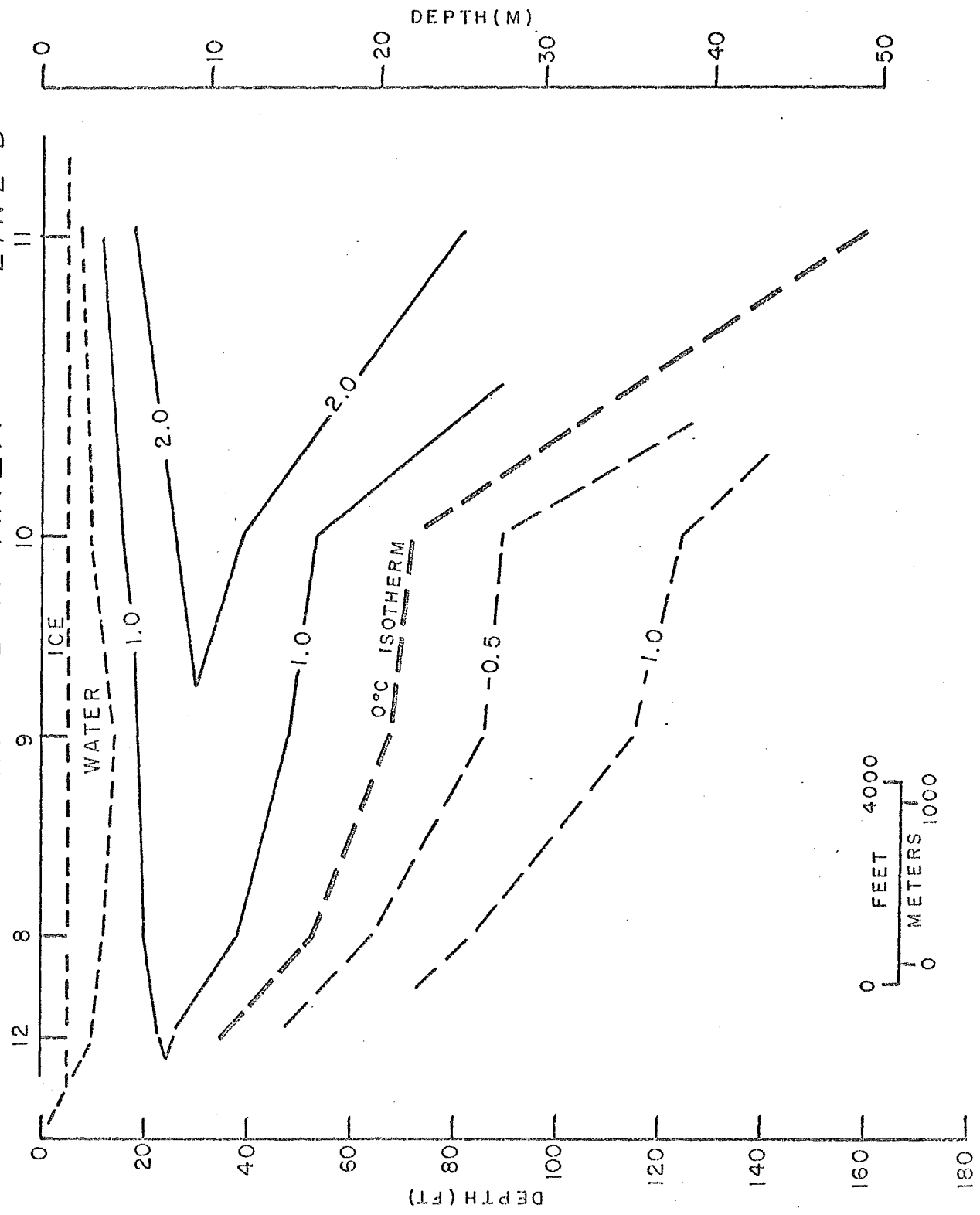

FEET 4000
METERS 1000

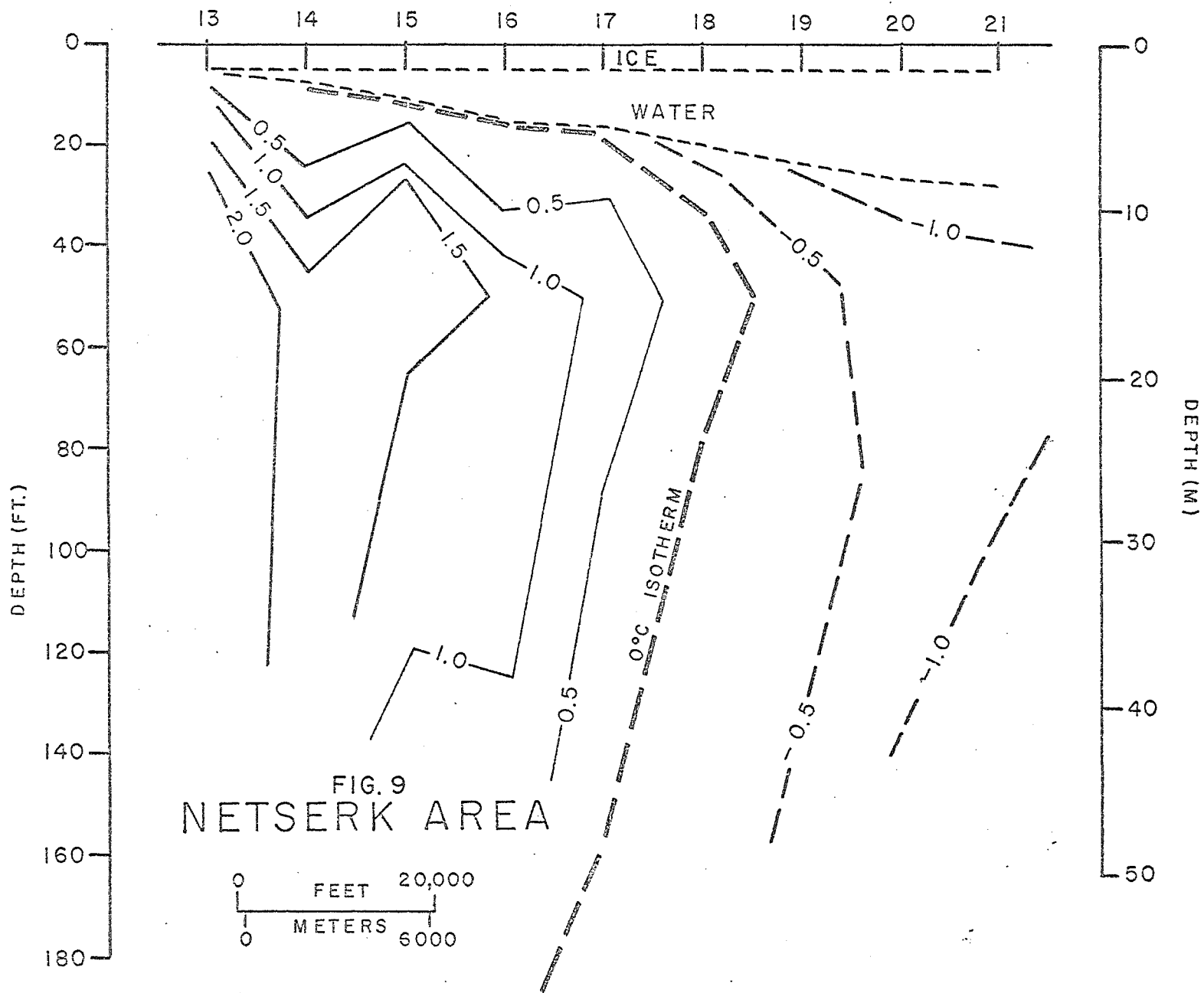

APPENDIX A

Lithologies, Drilling Rates, Temperatures
and Other Geophysics Measurements in
Boreholes

46 1513

1407 15 13 15 13 15 13 15 13

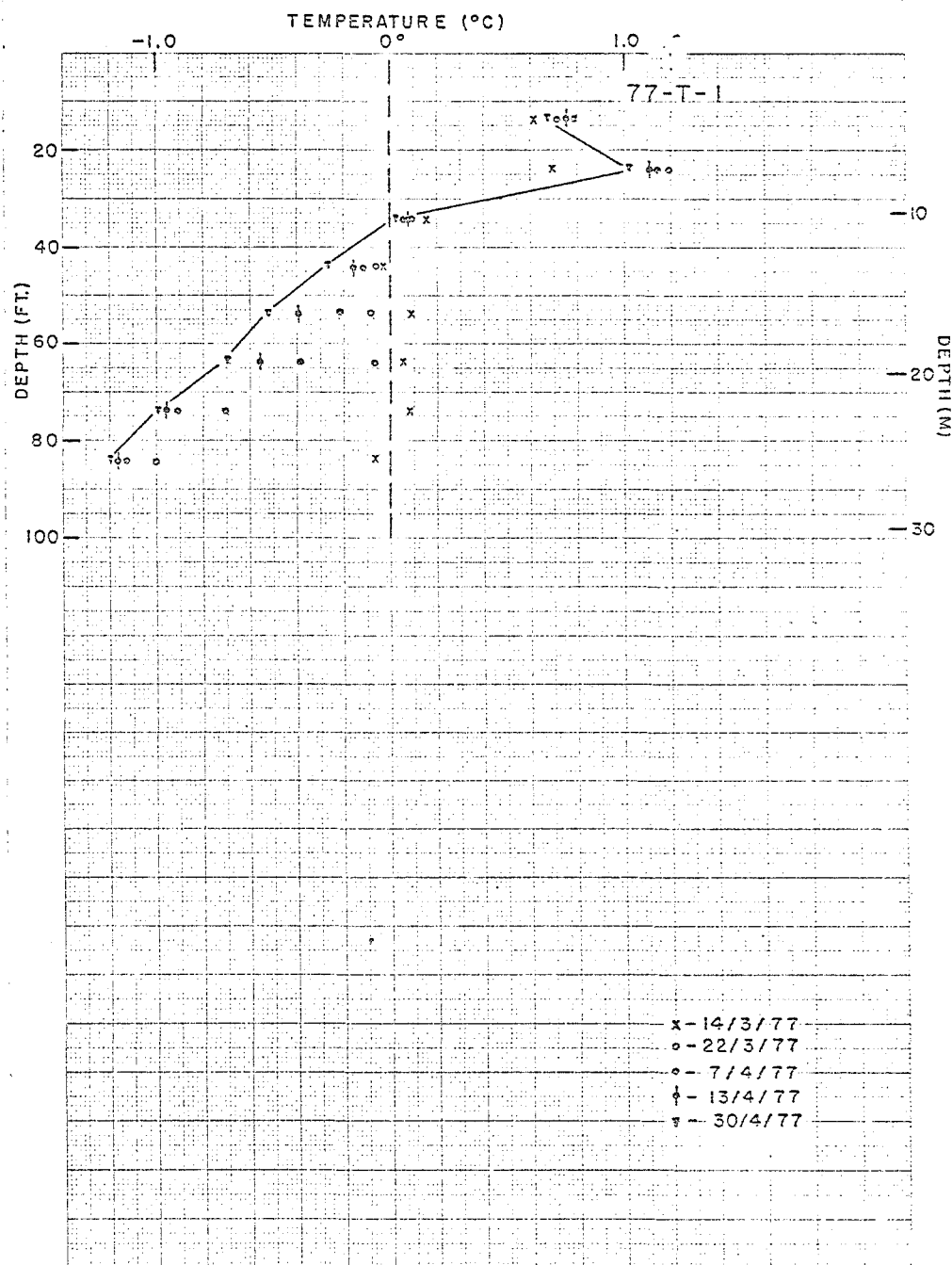
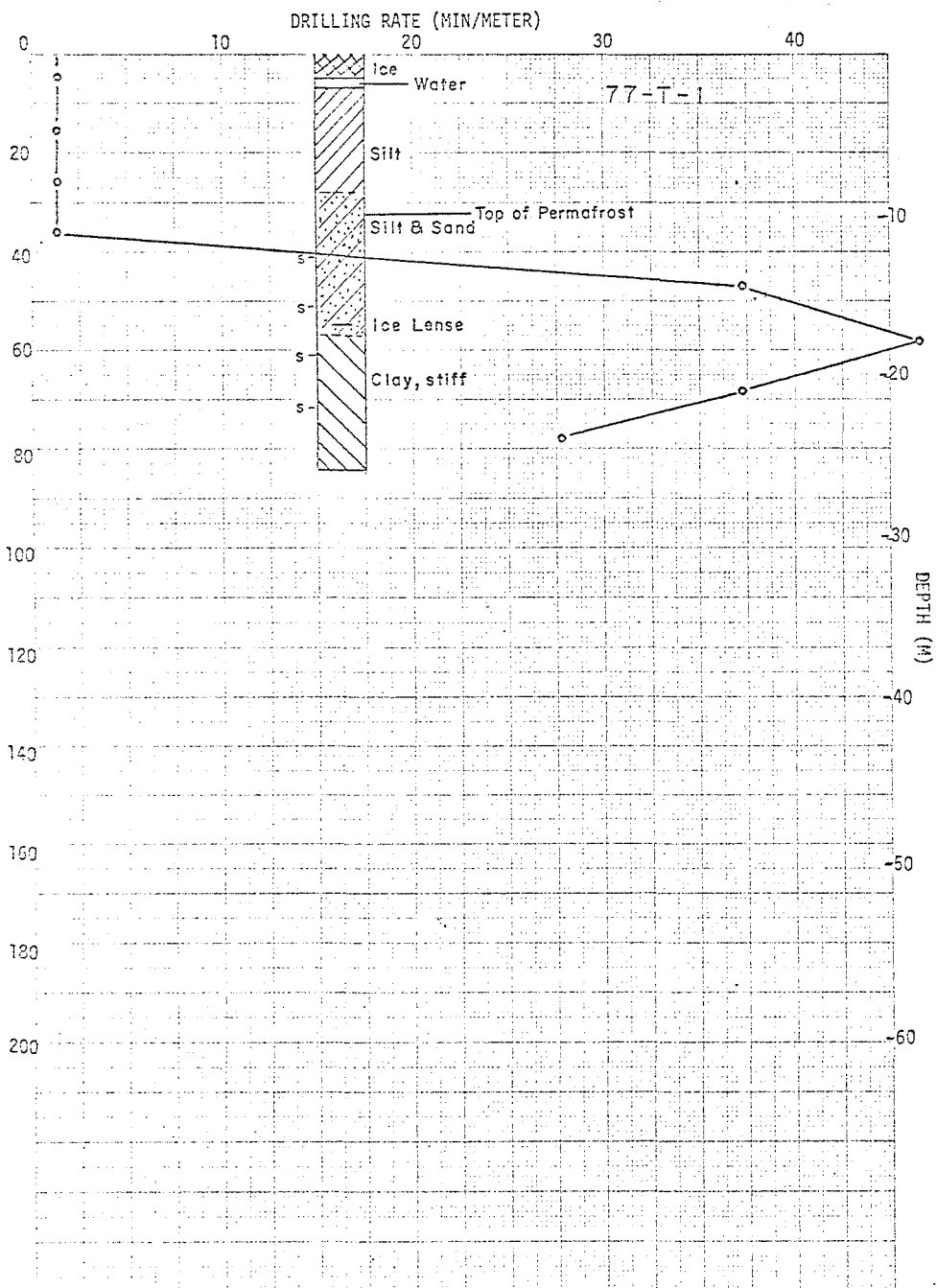

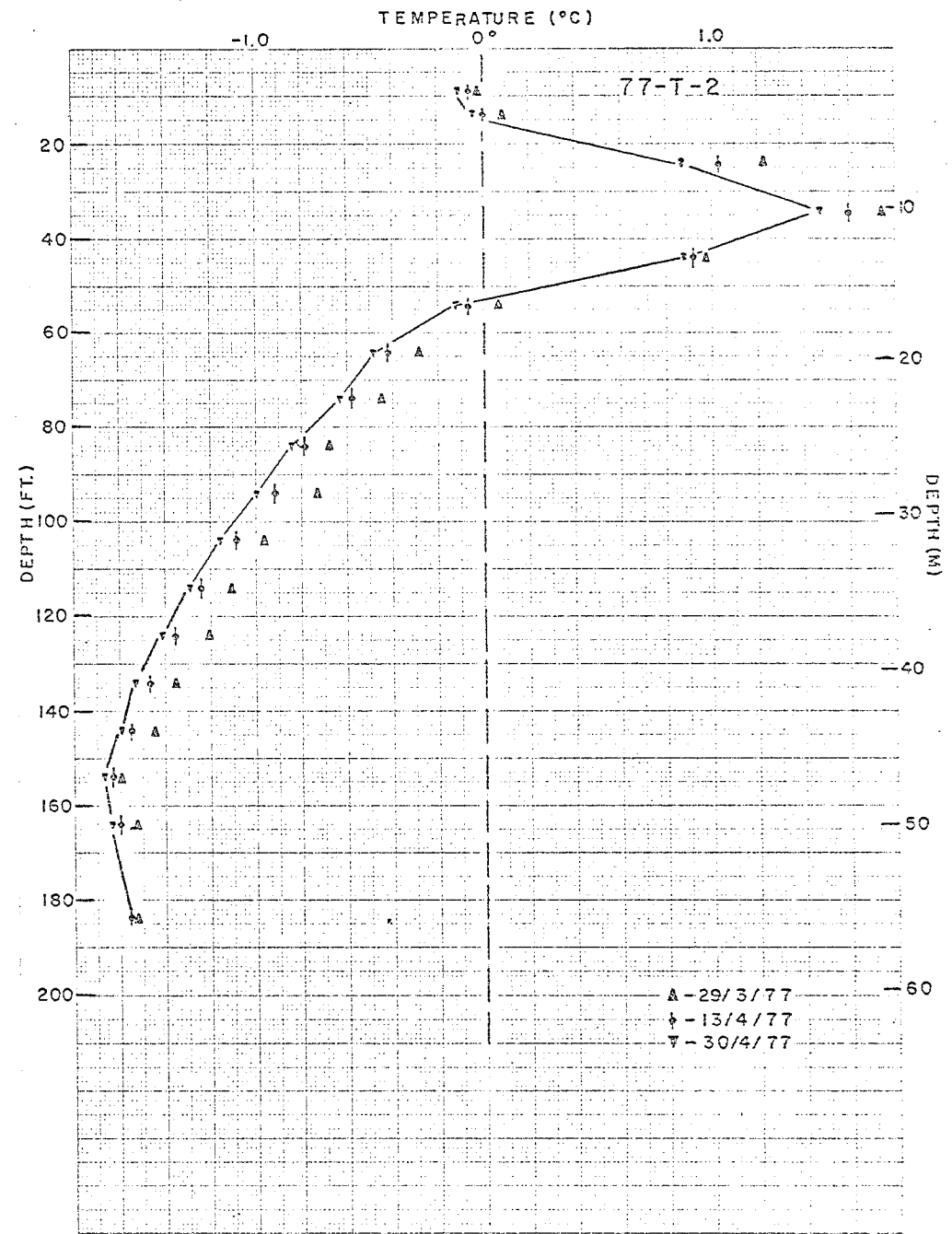
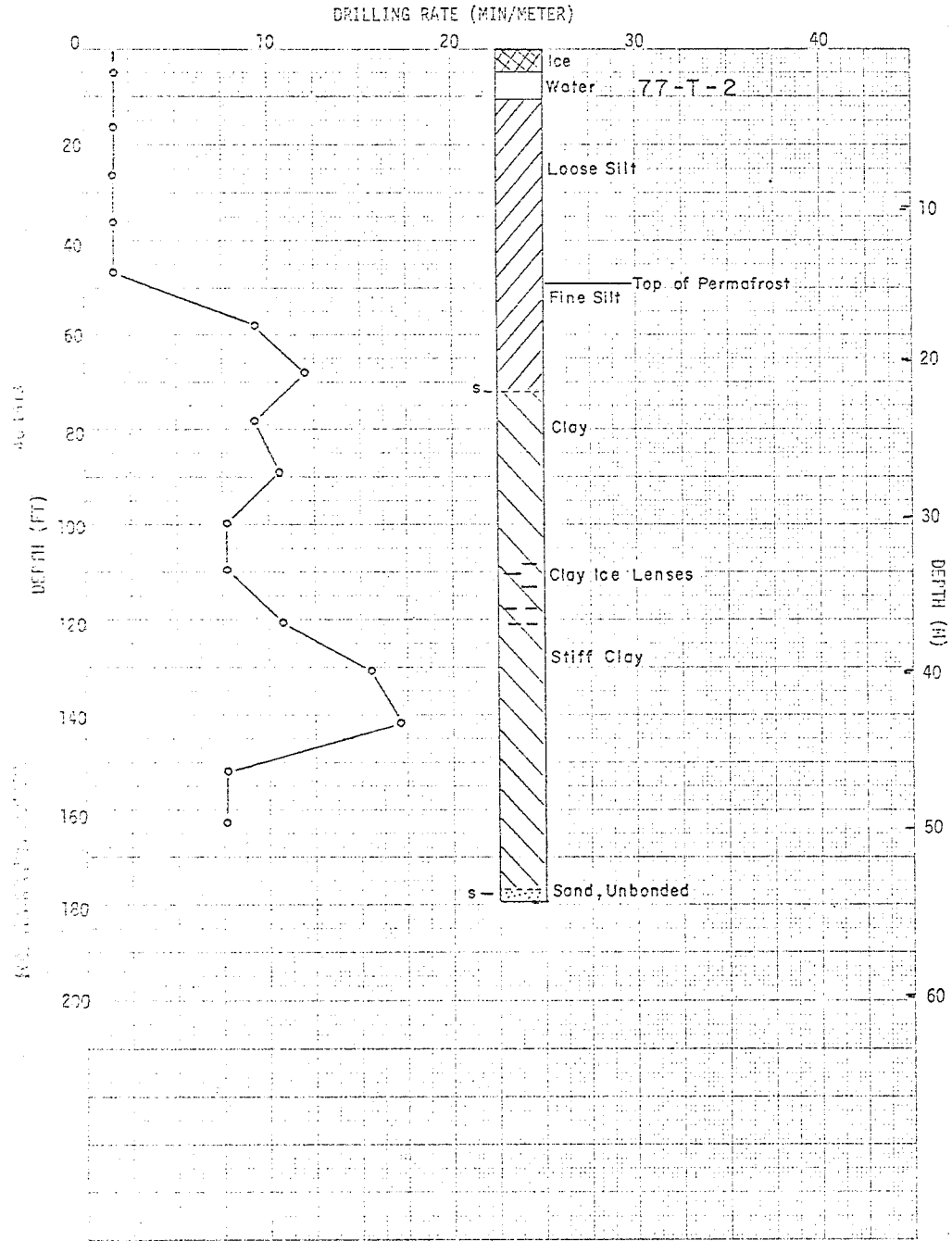

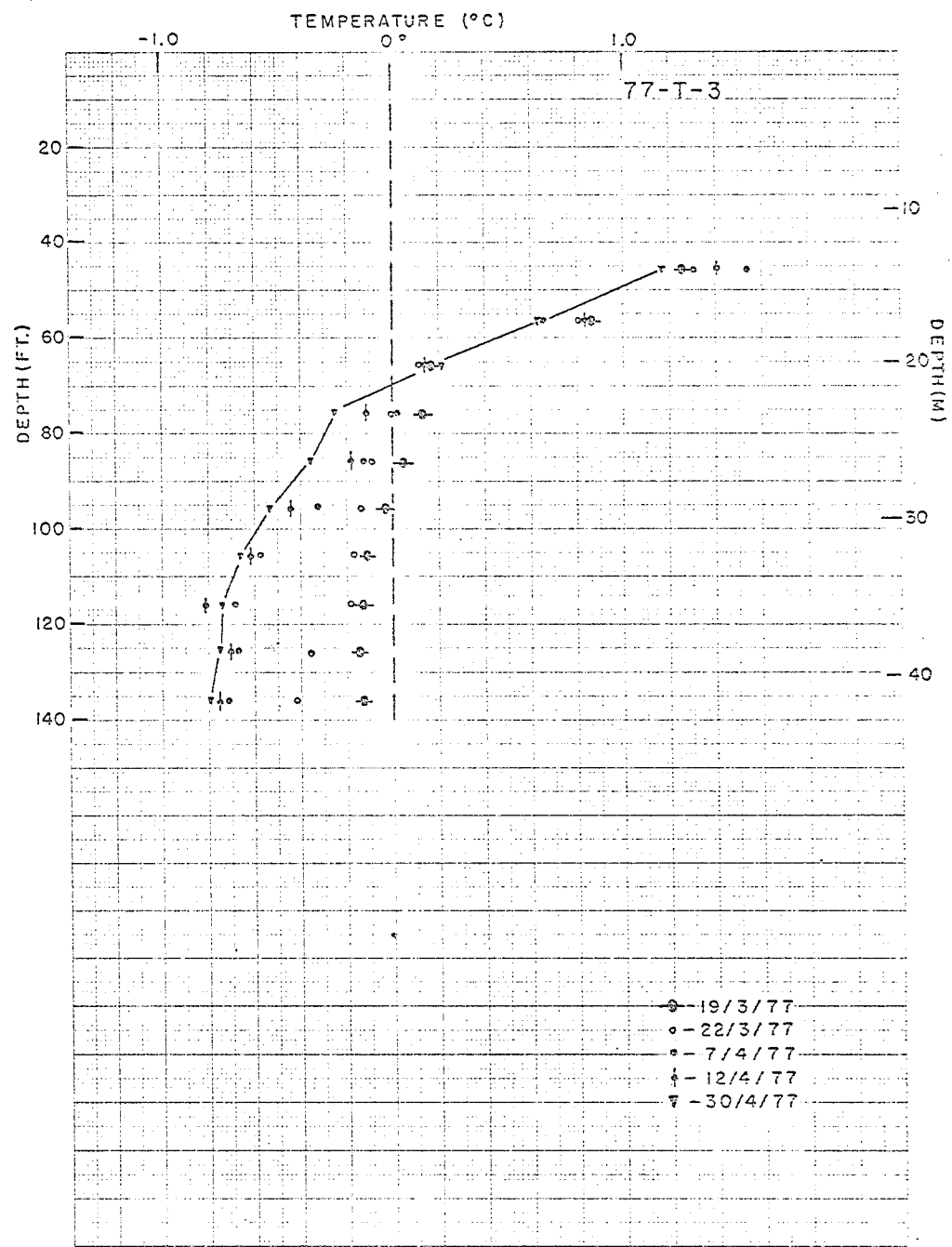
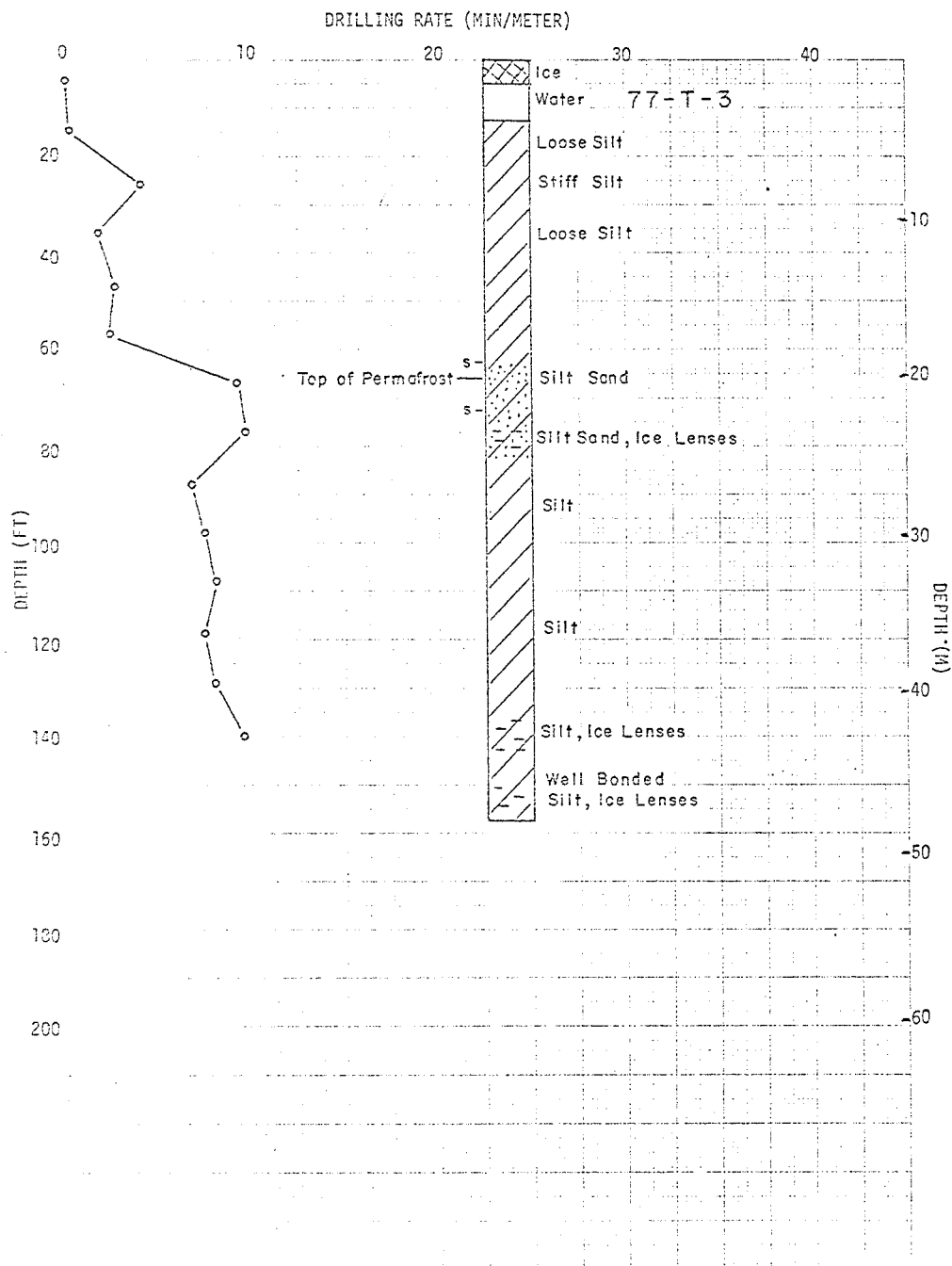

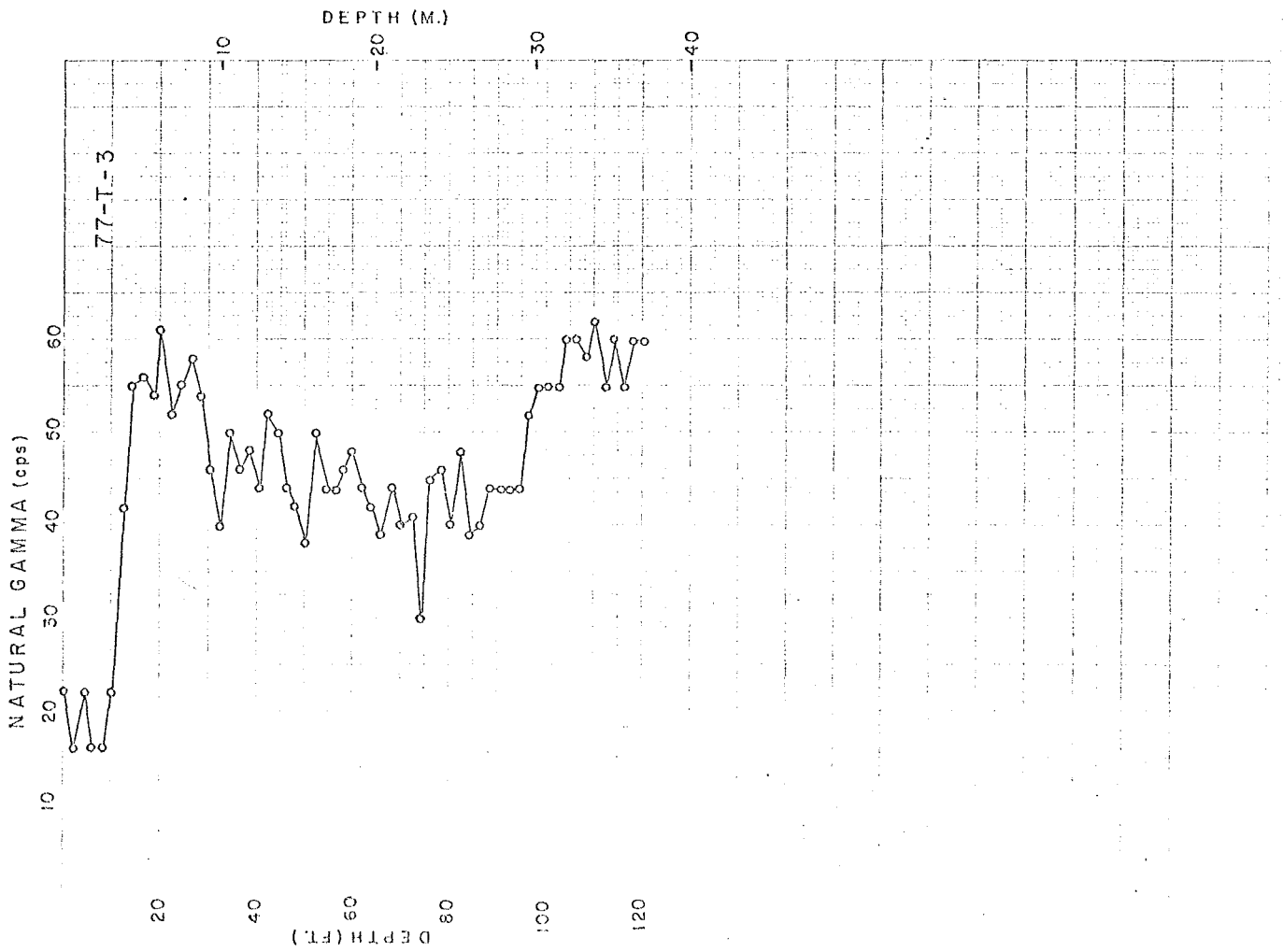

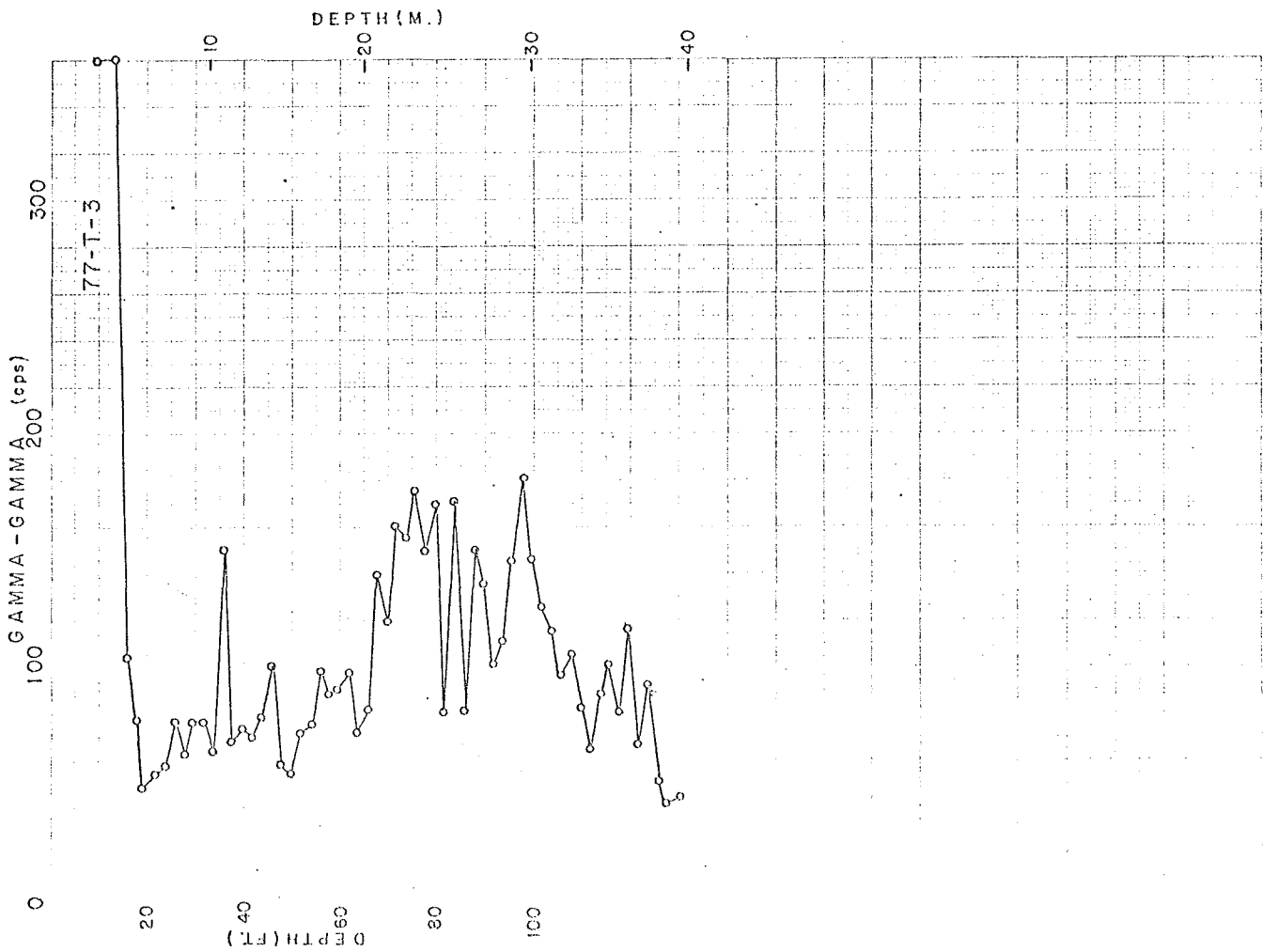

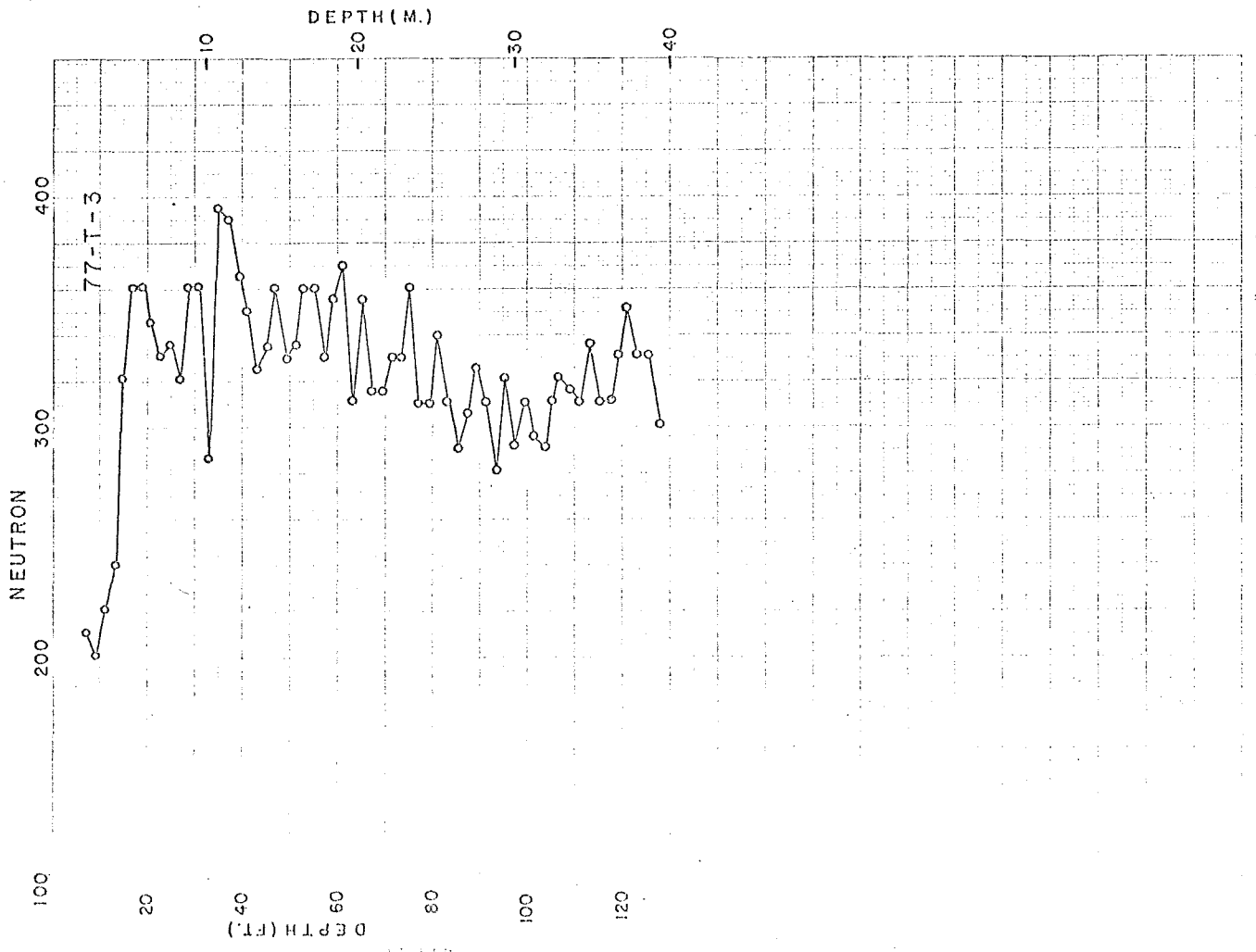

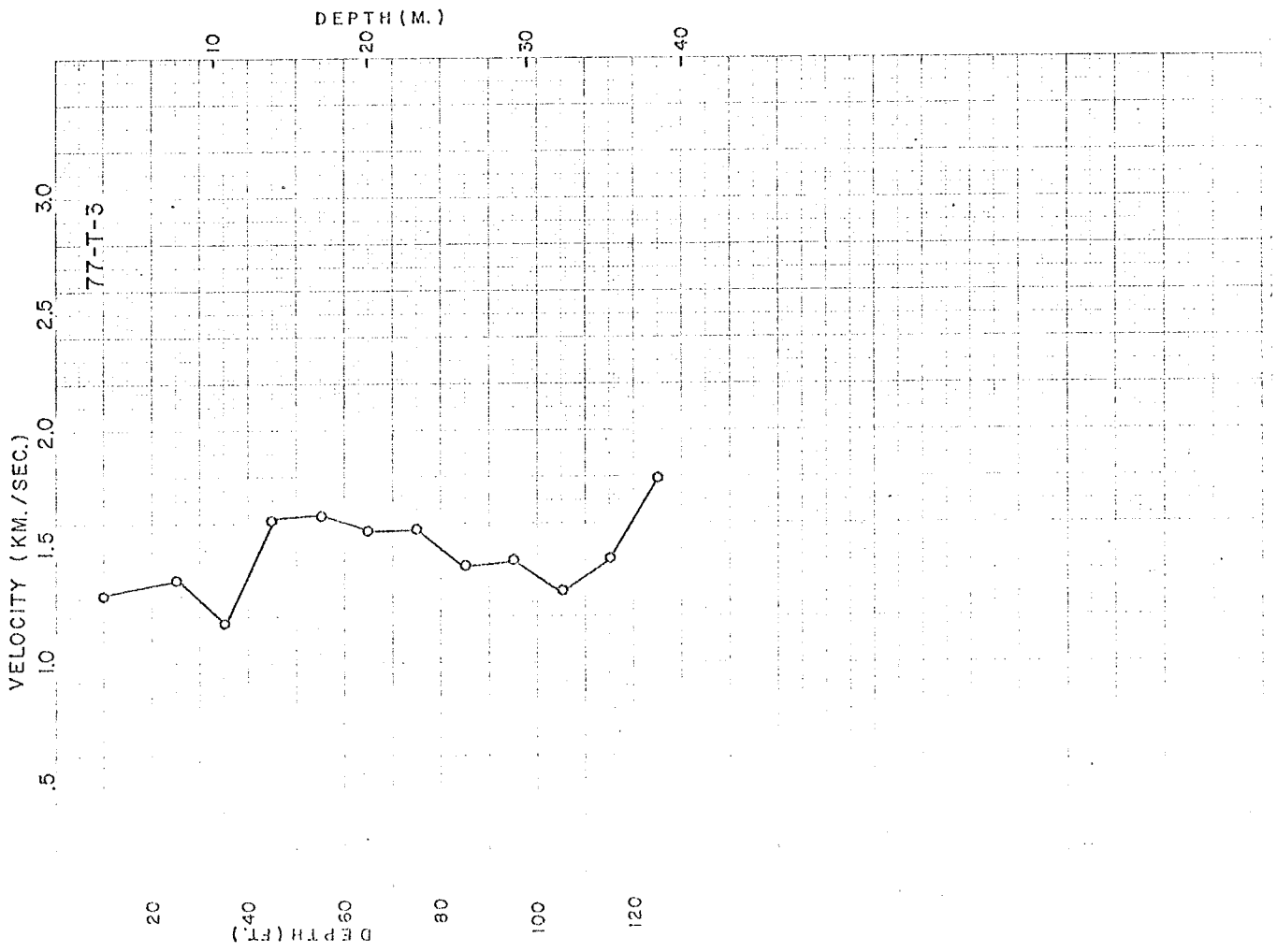

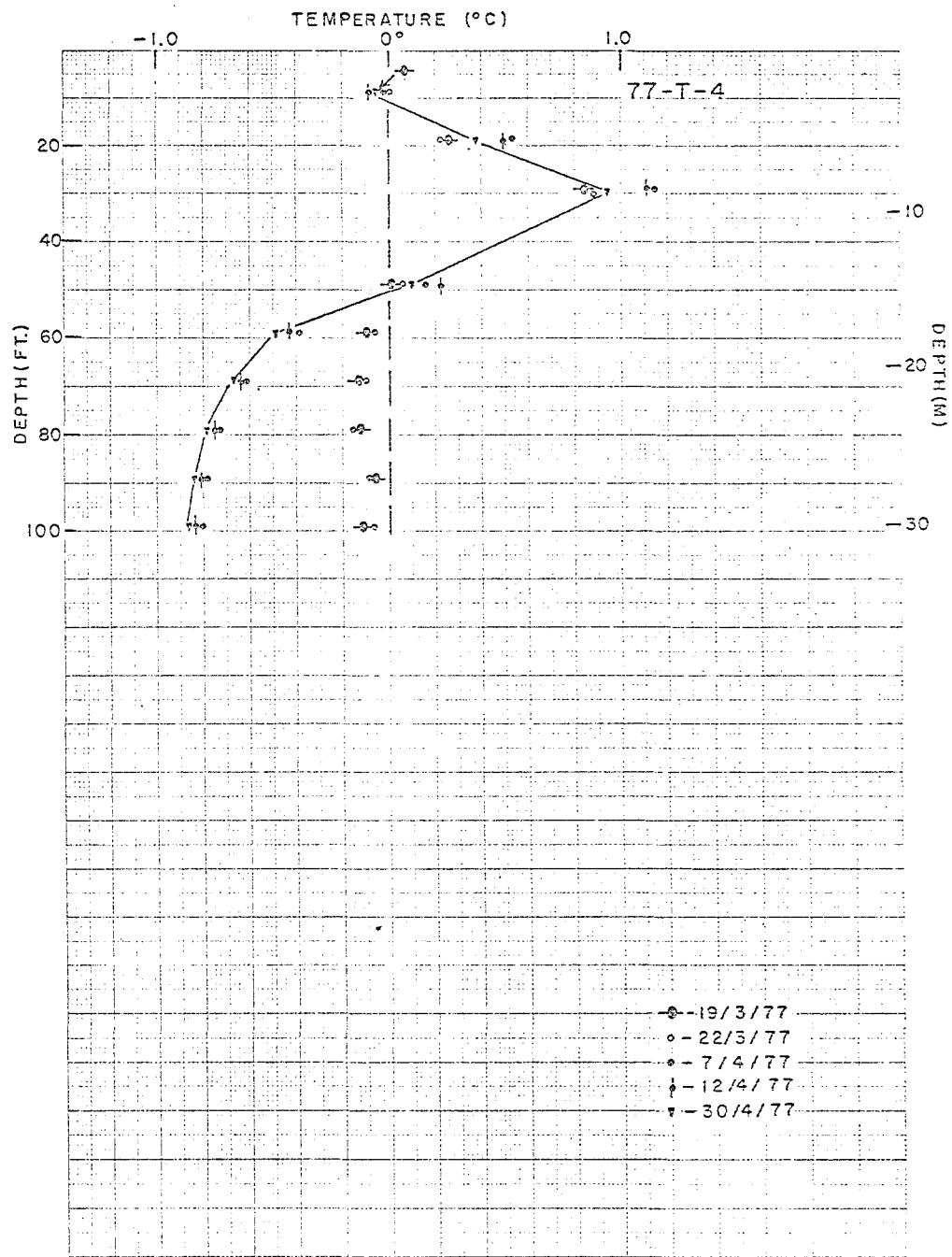
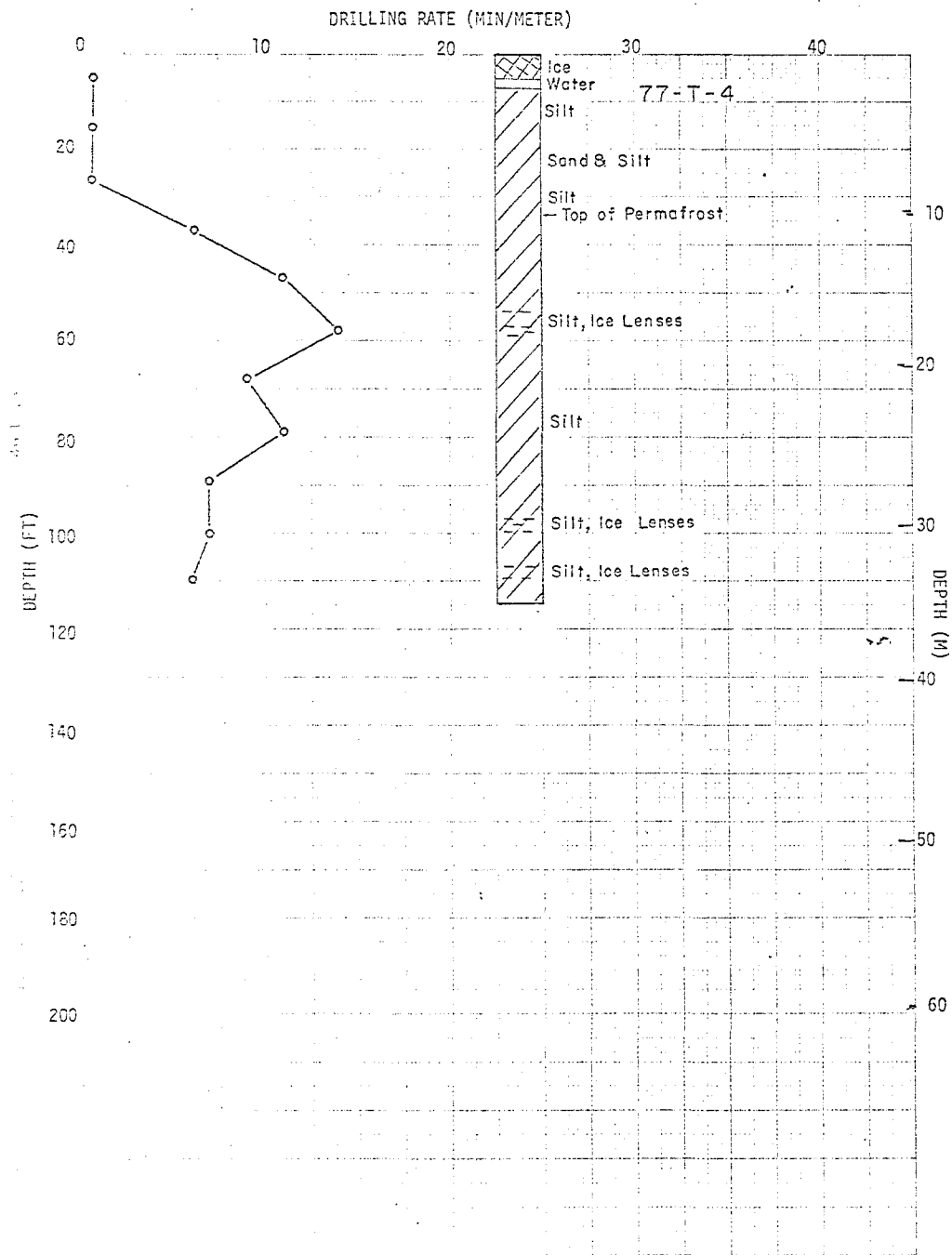

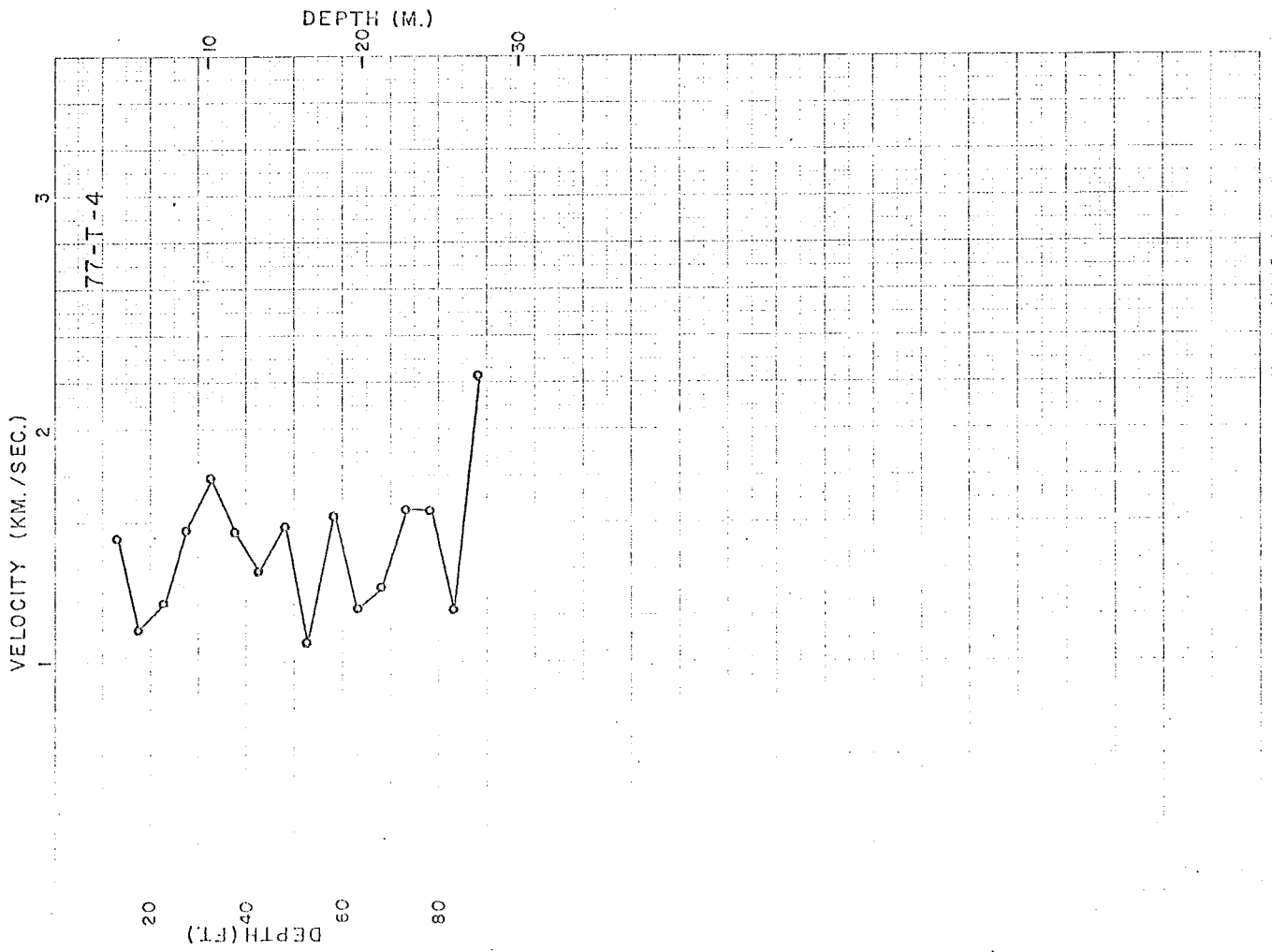

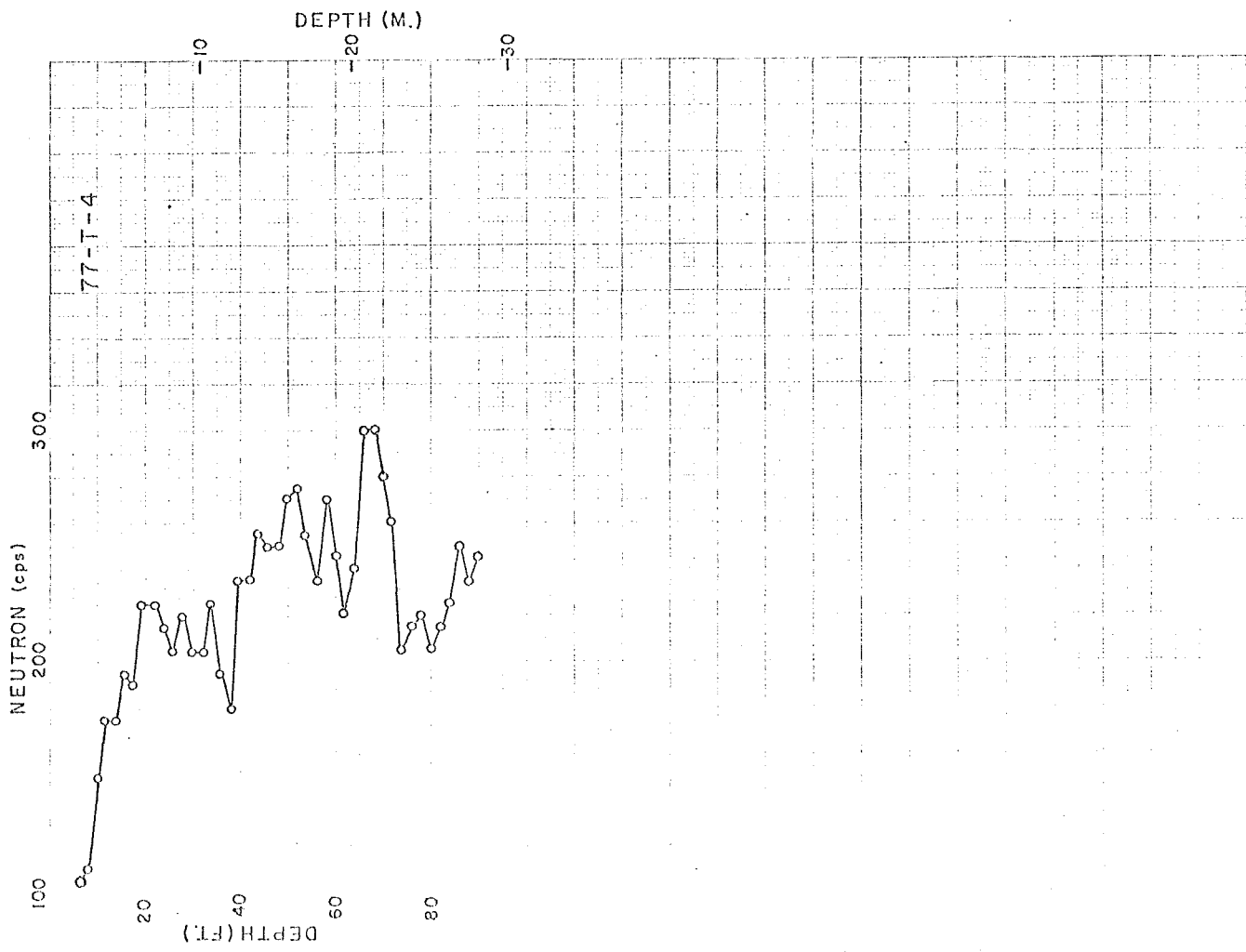

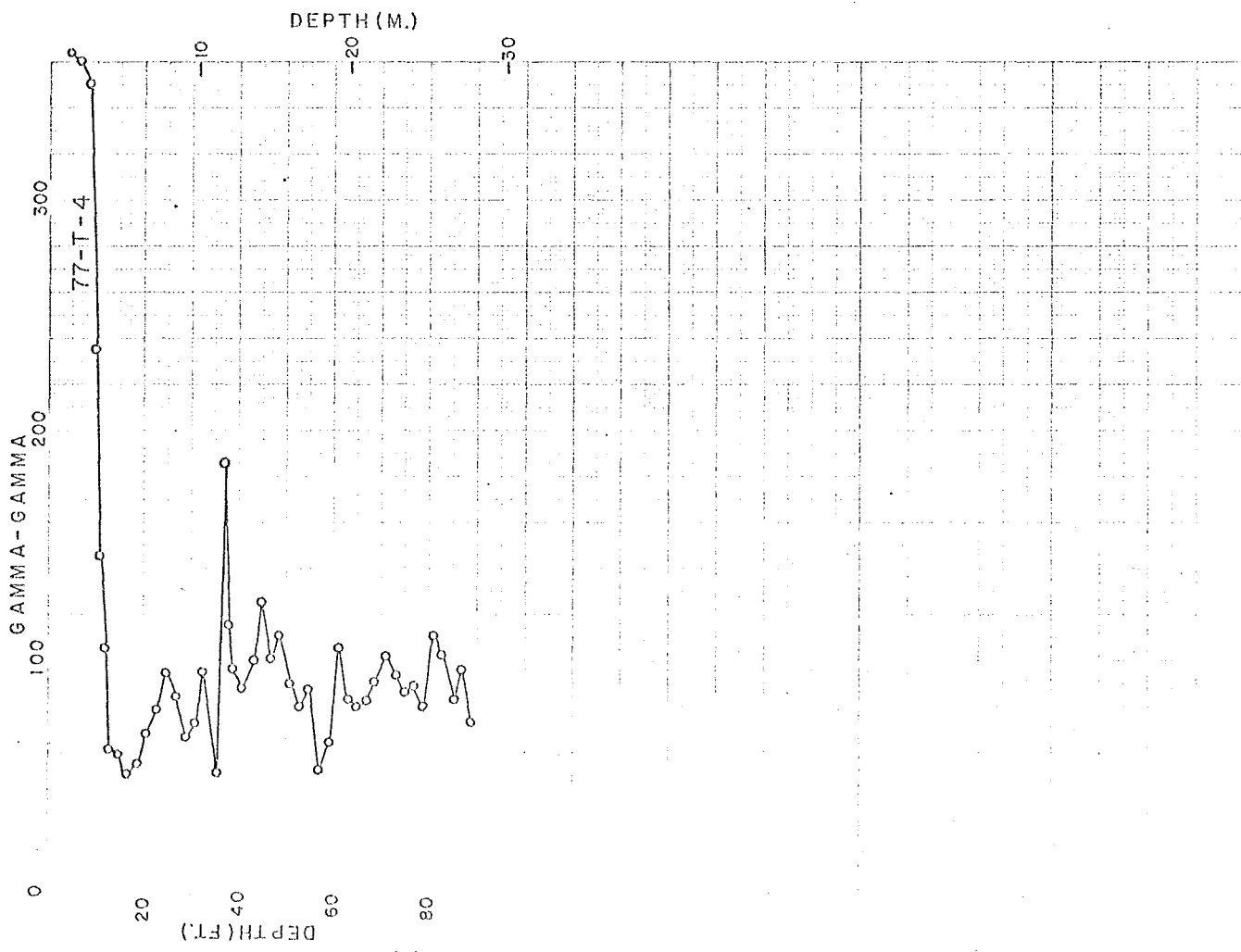

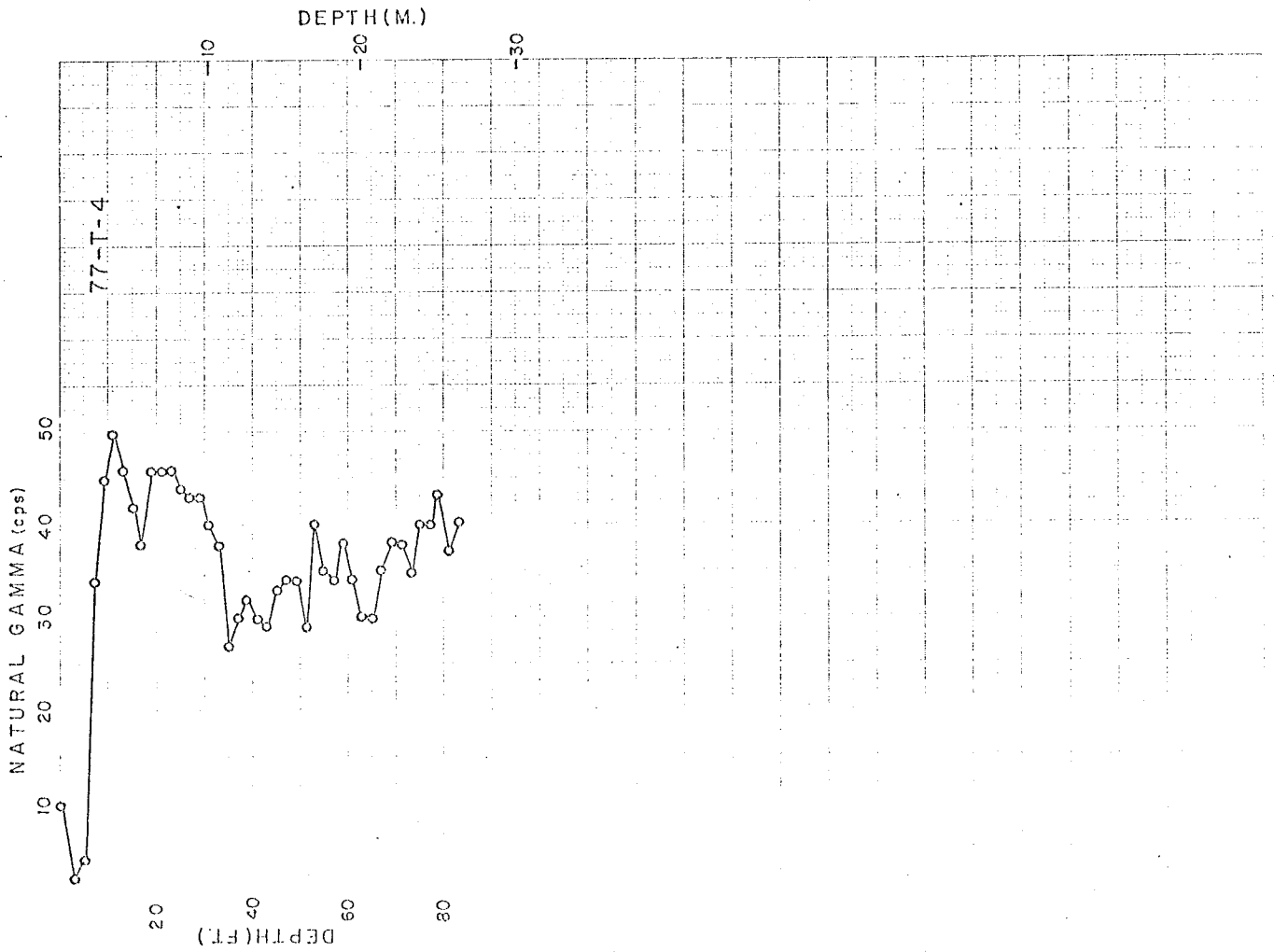

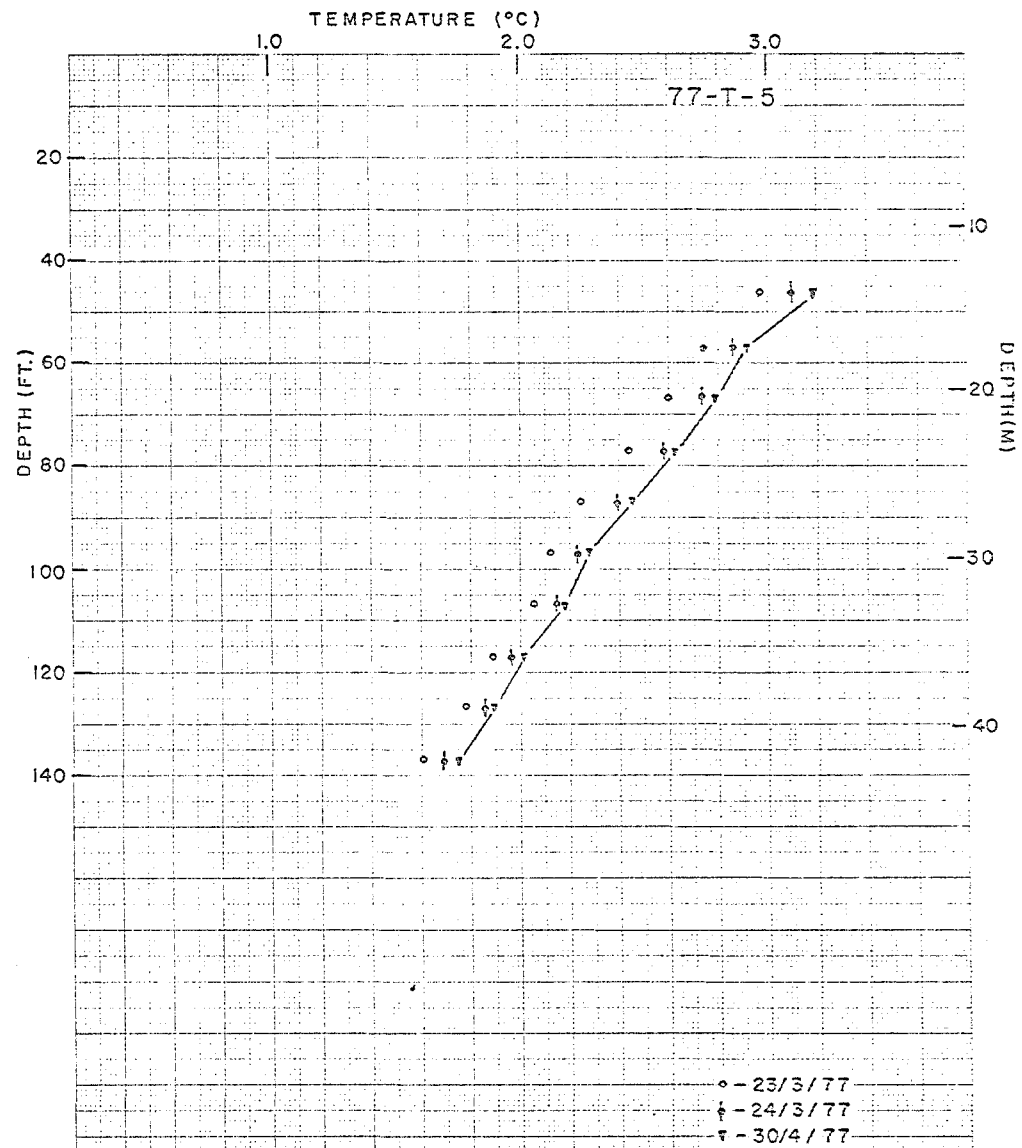
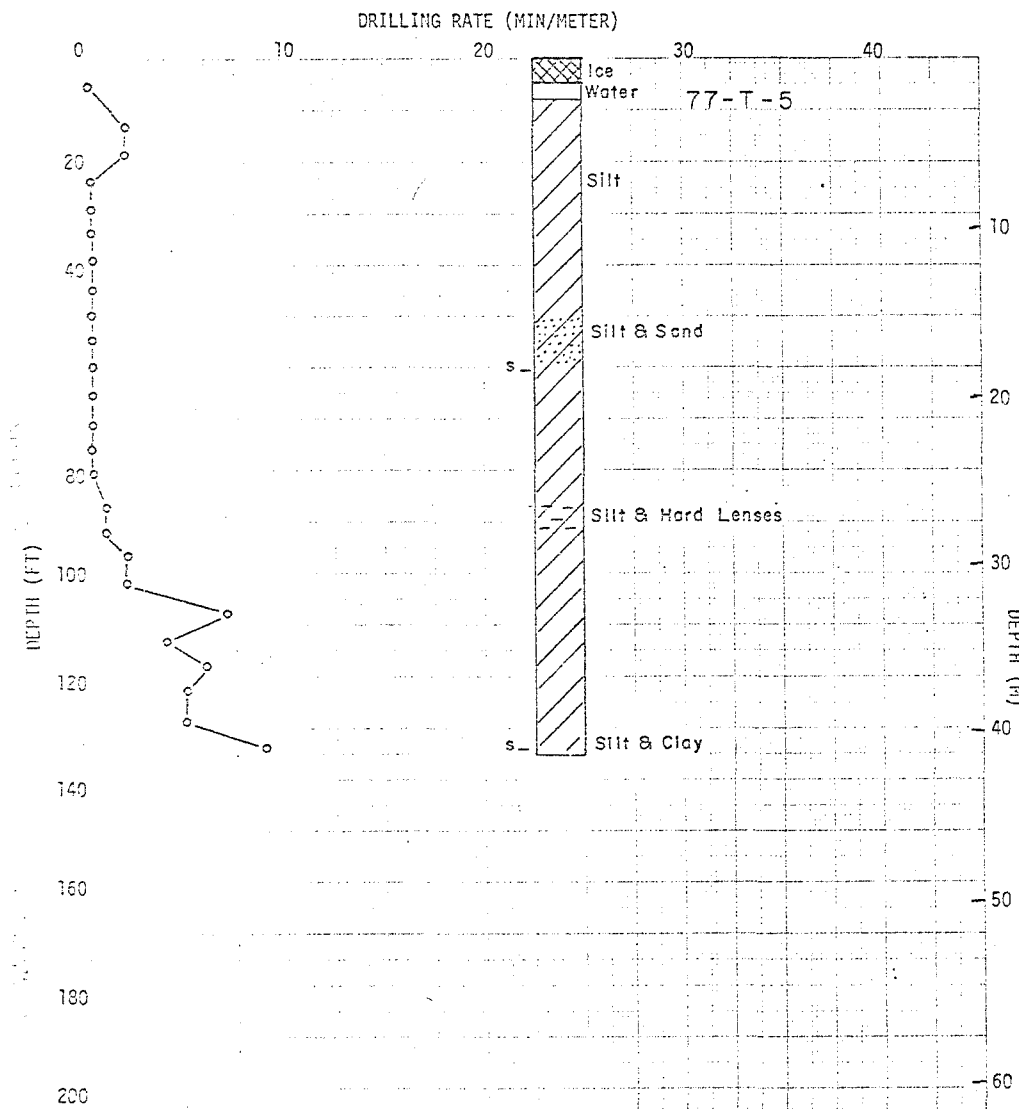

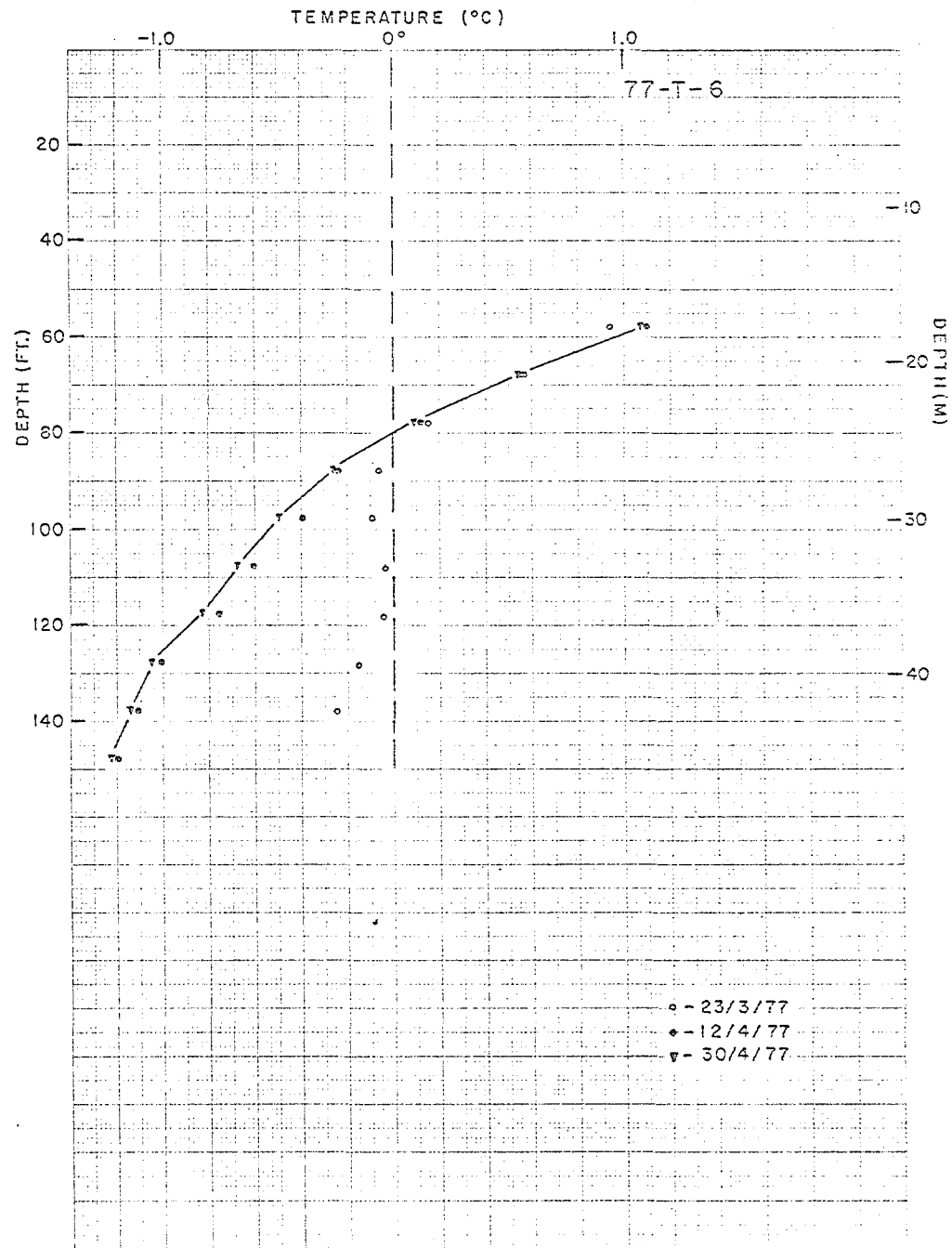
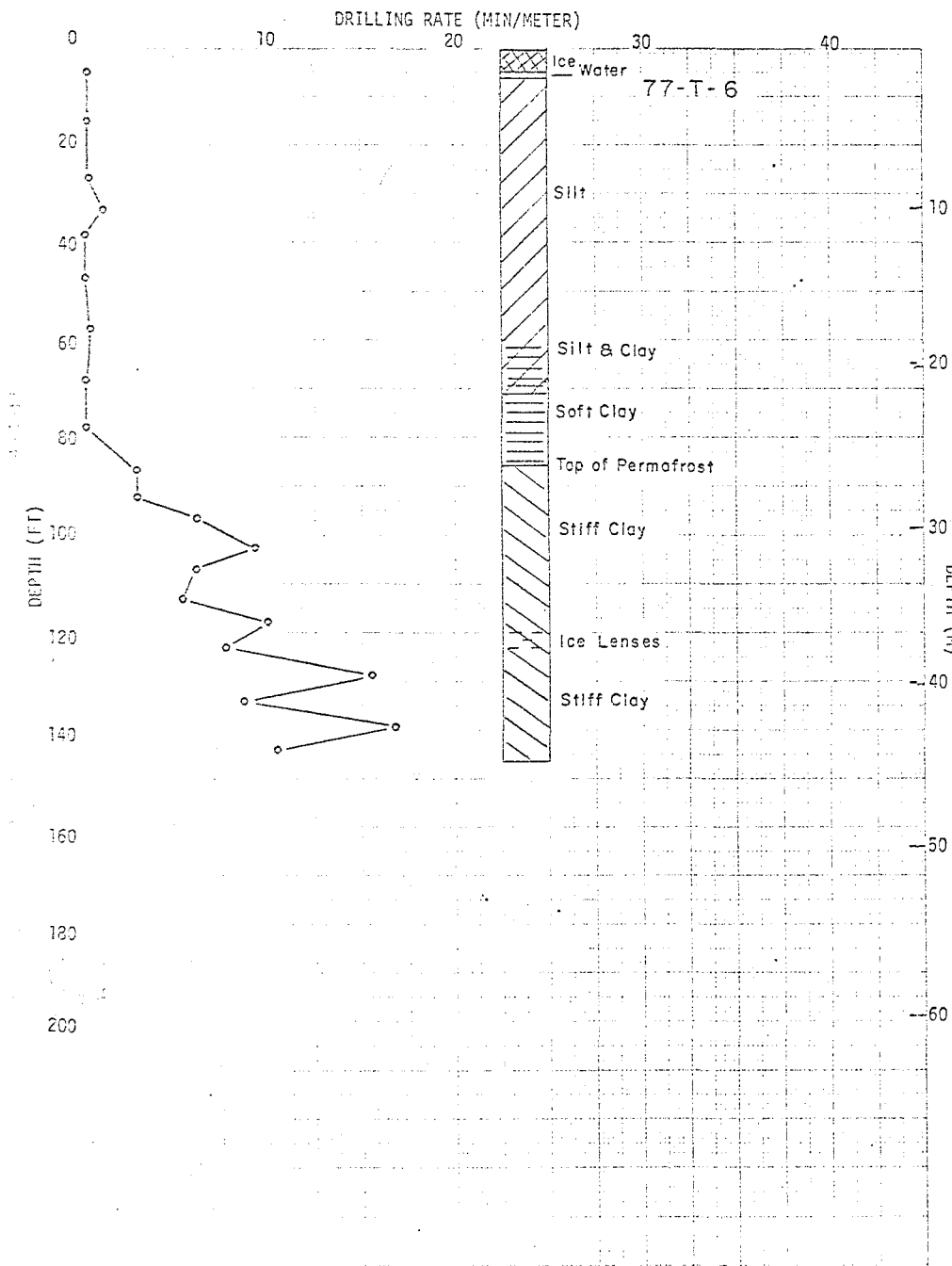

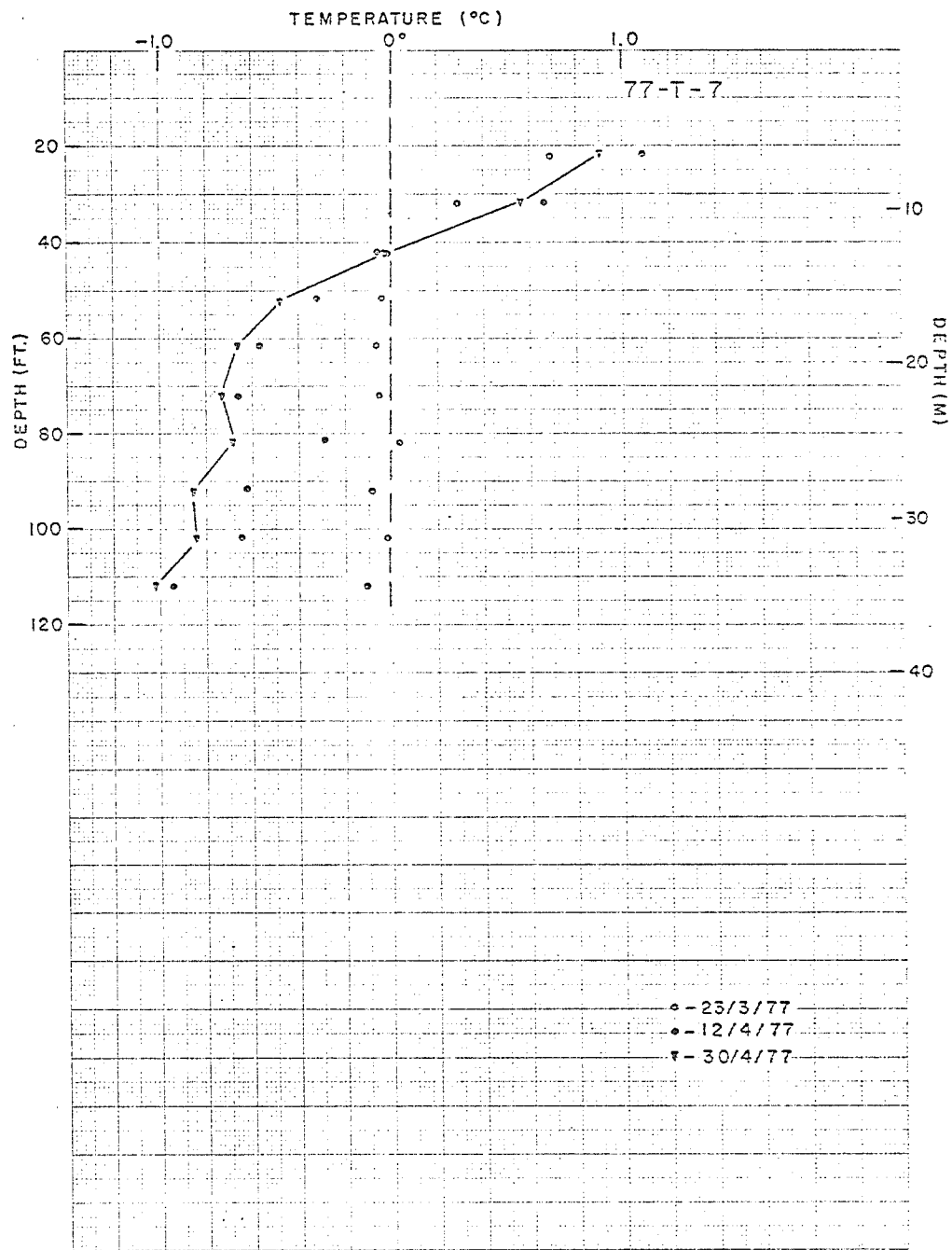
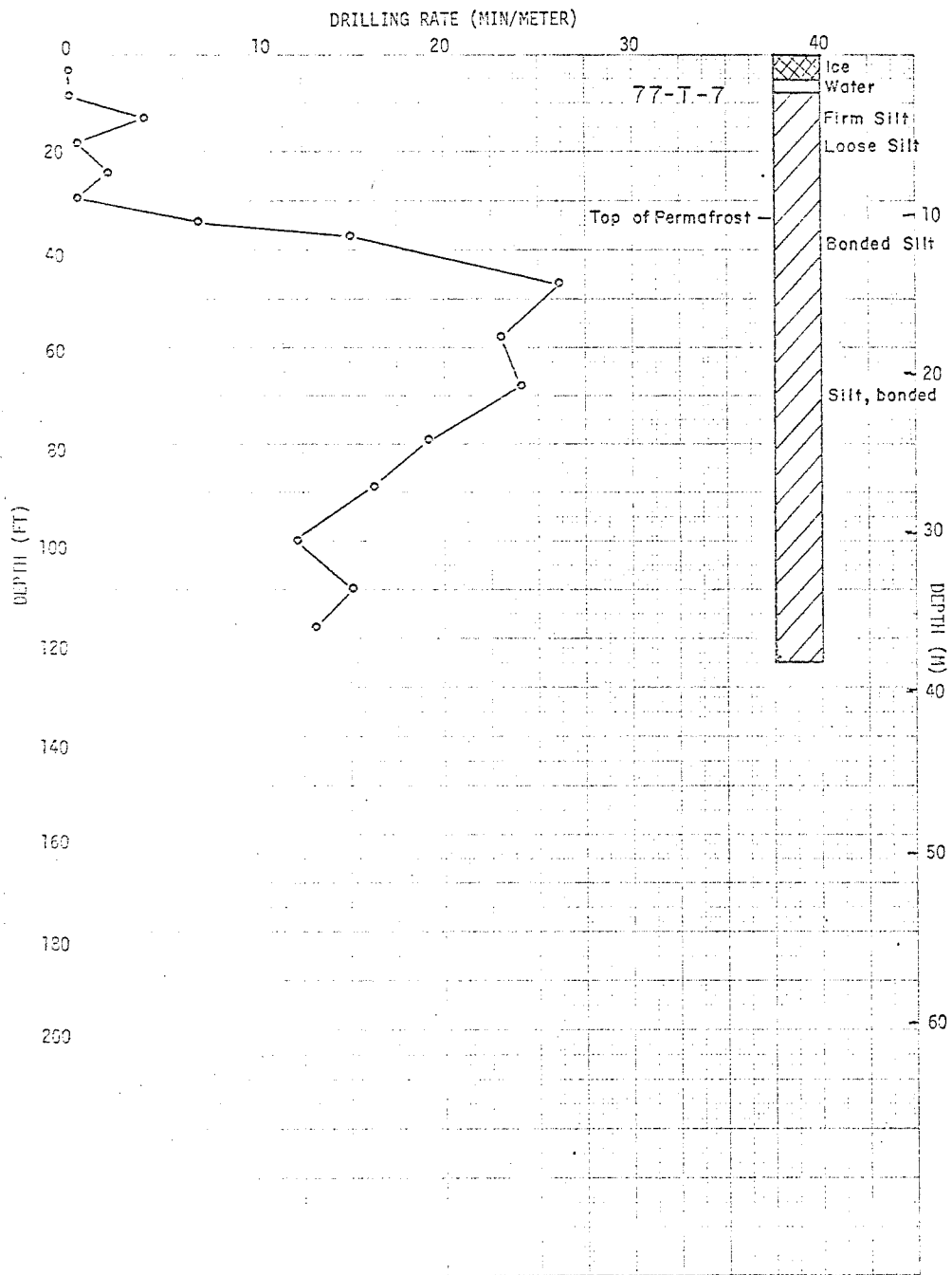

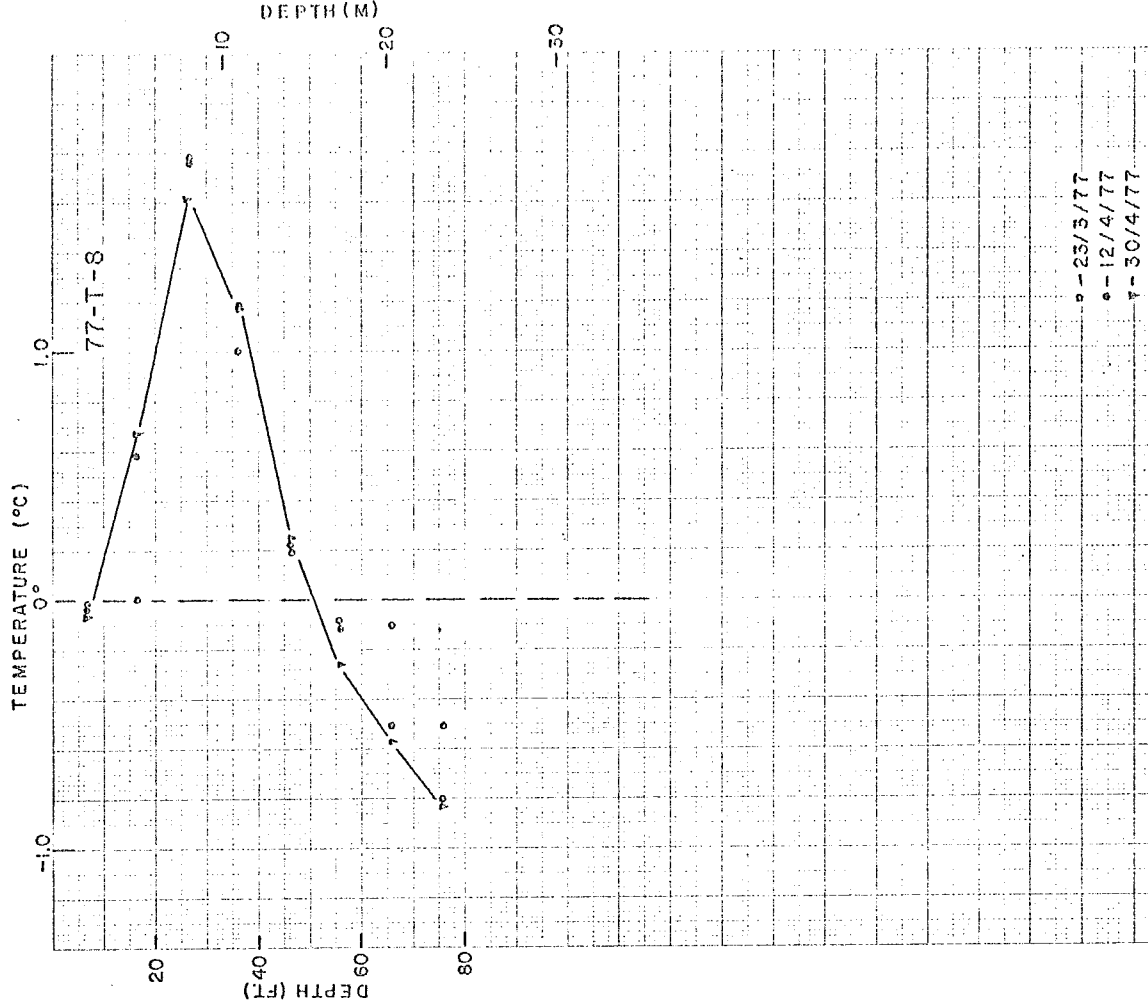
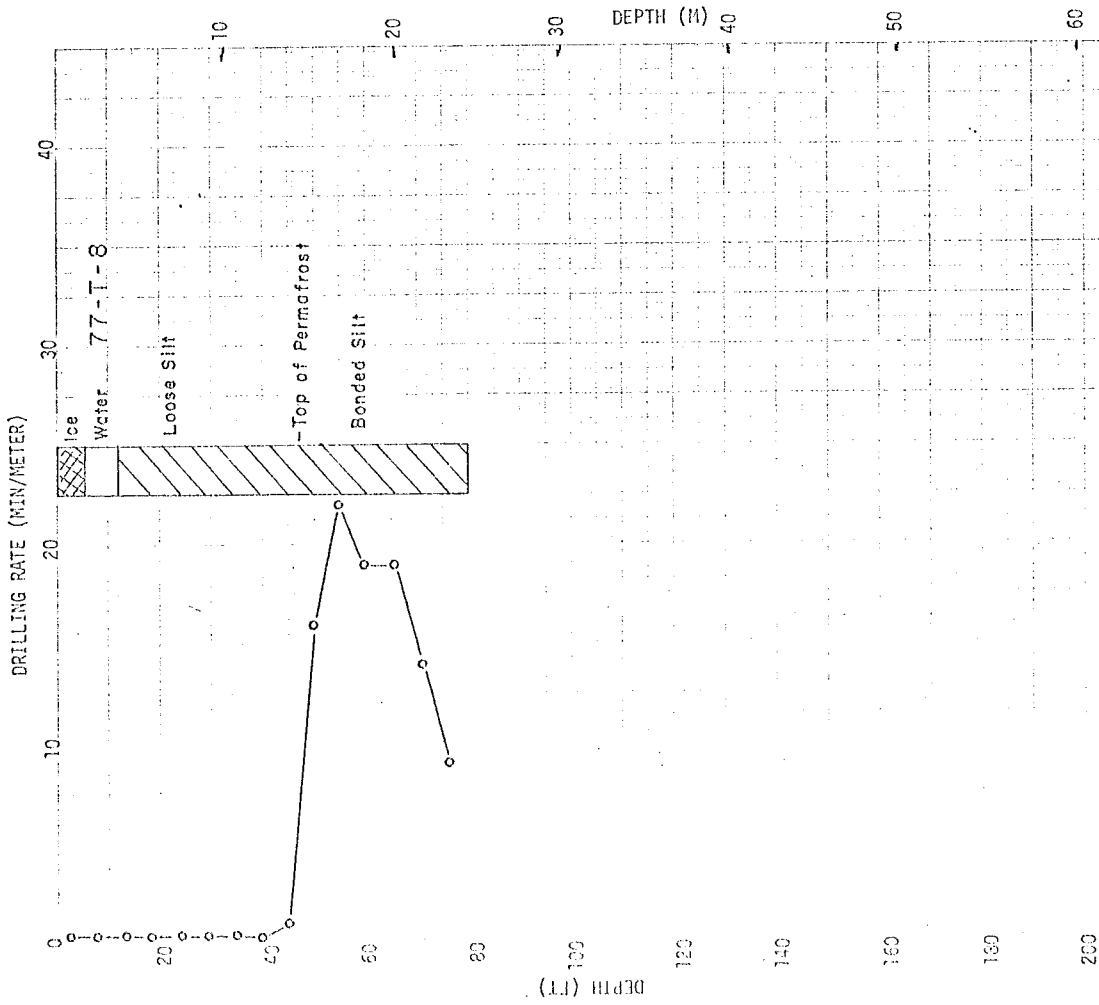

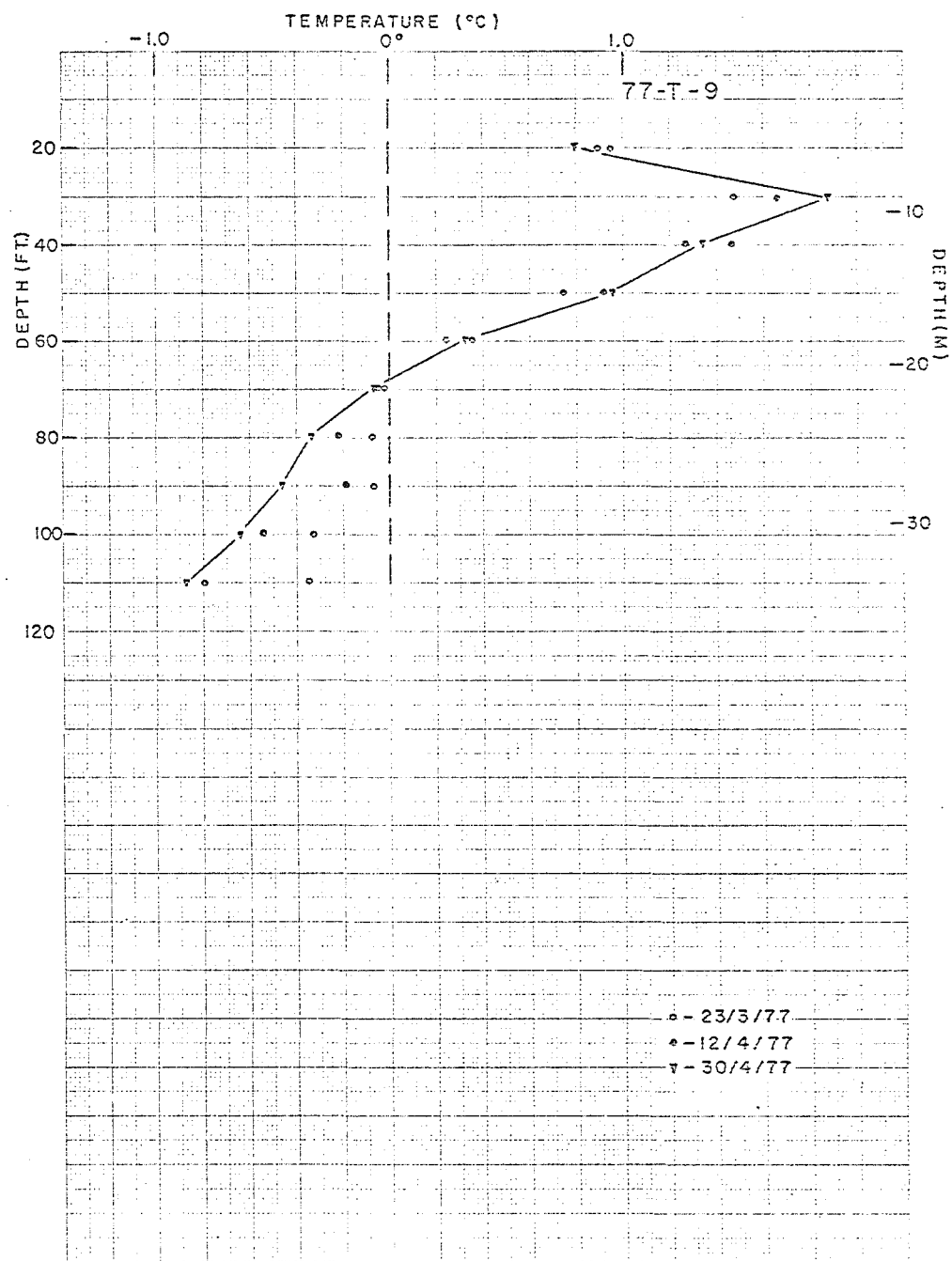
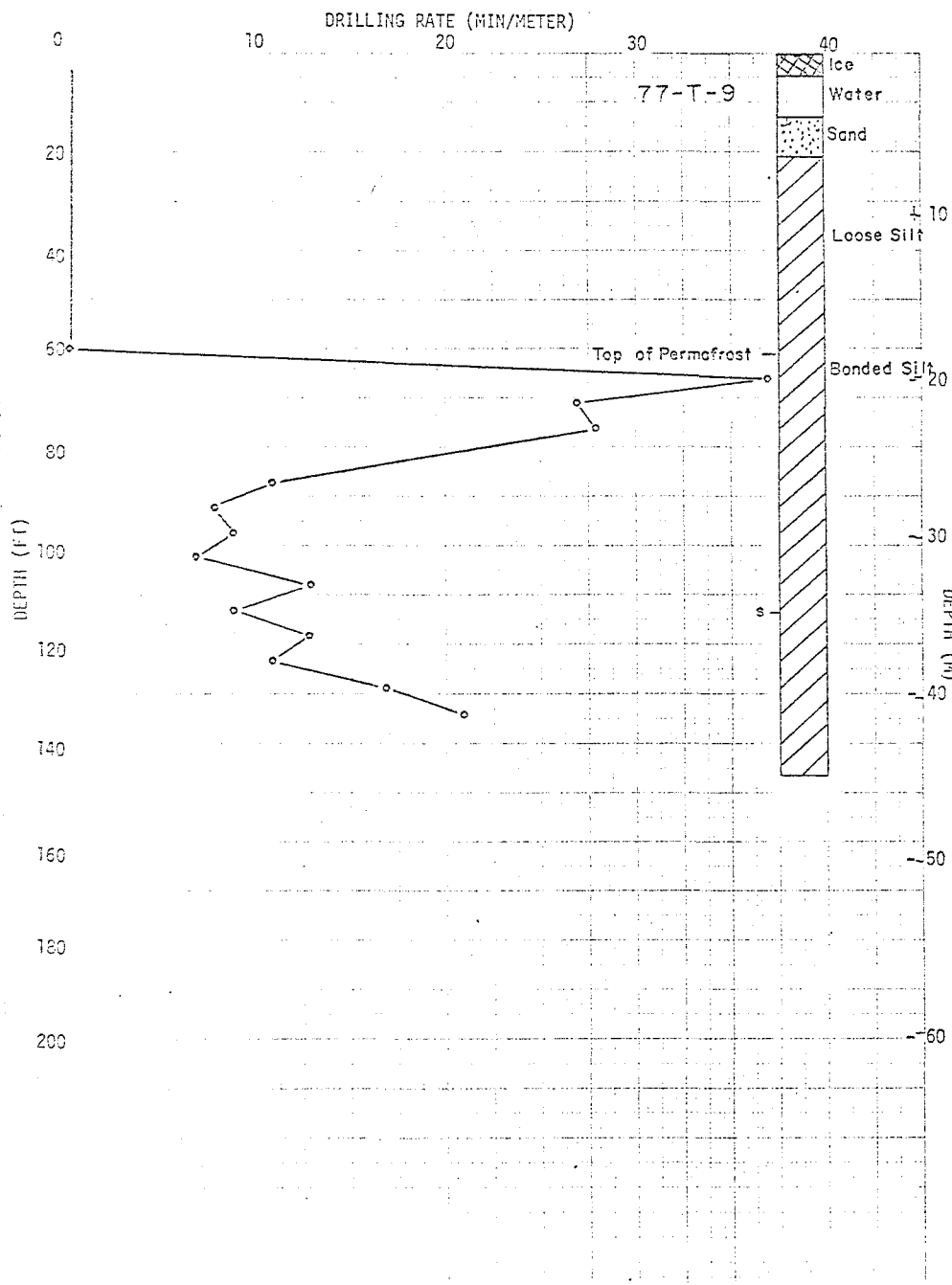

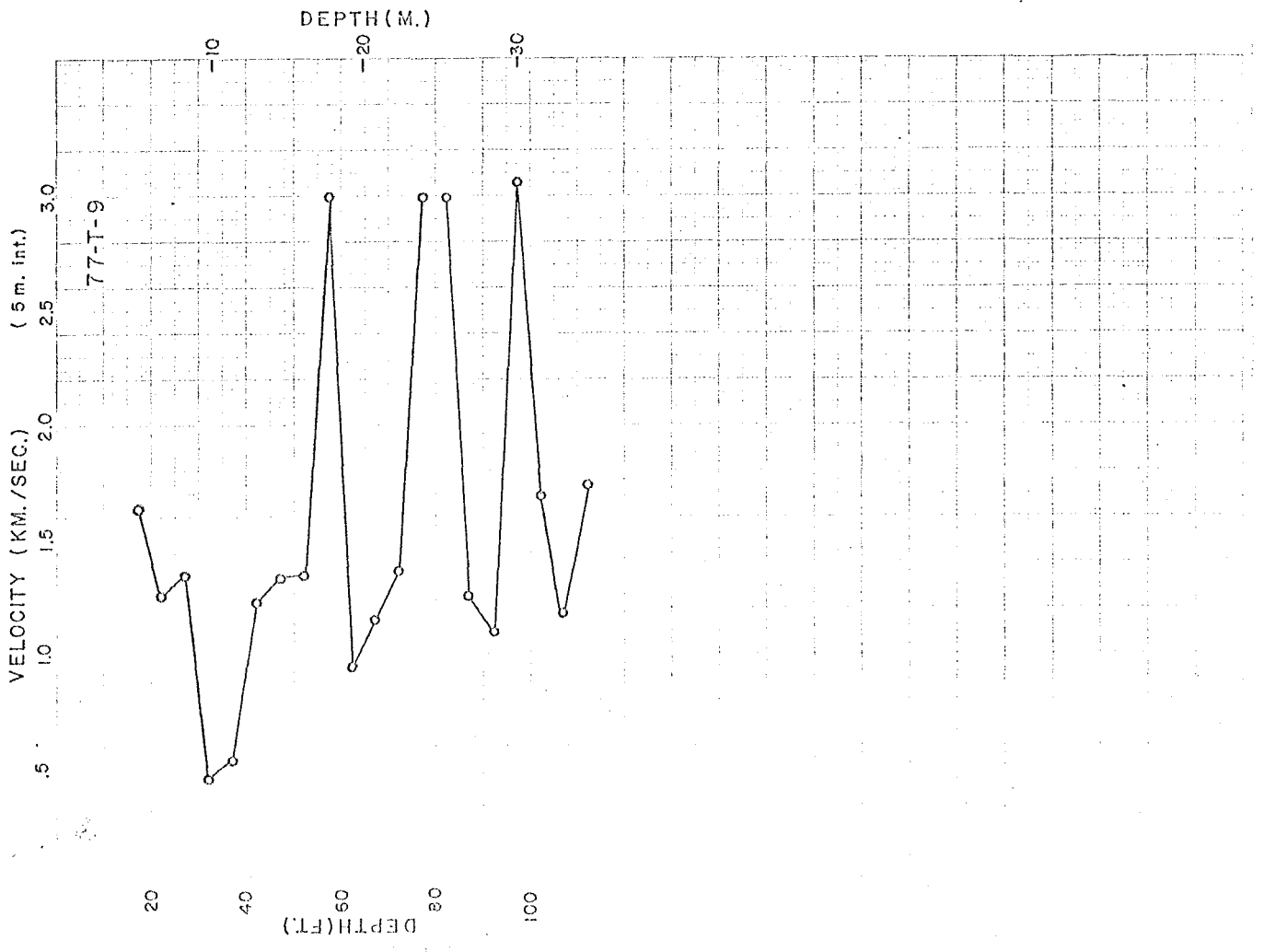

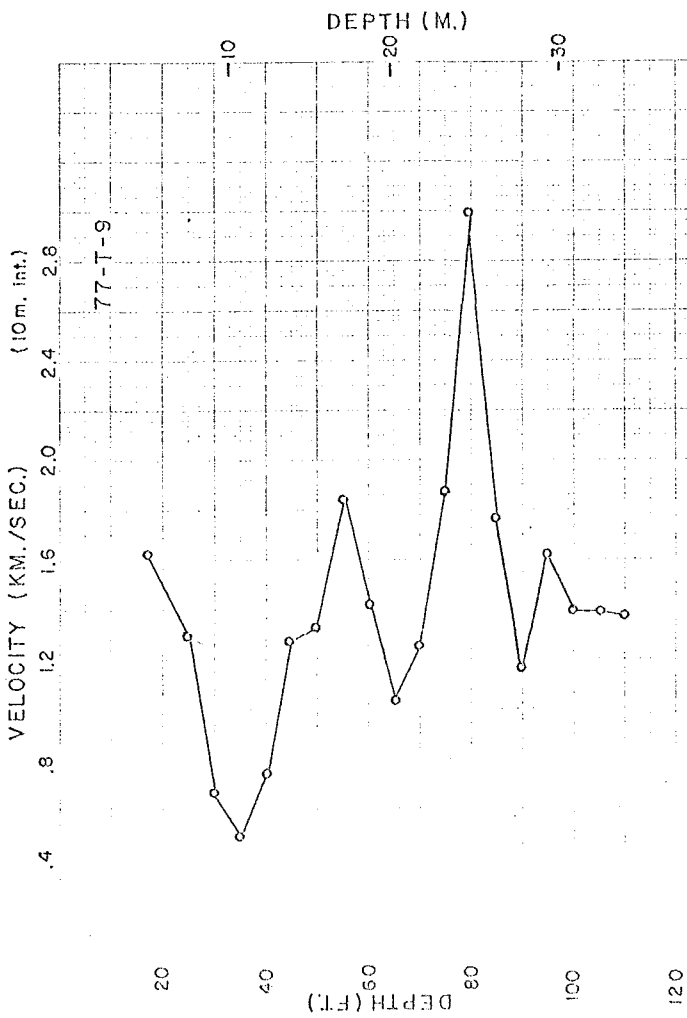

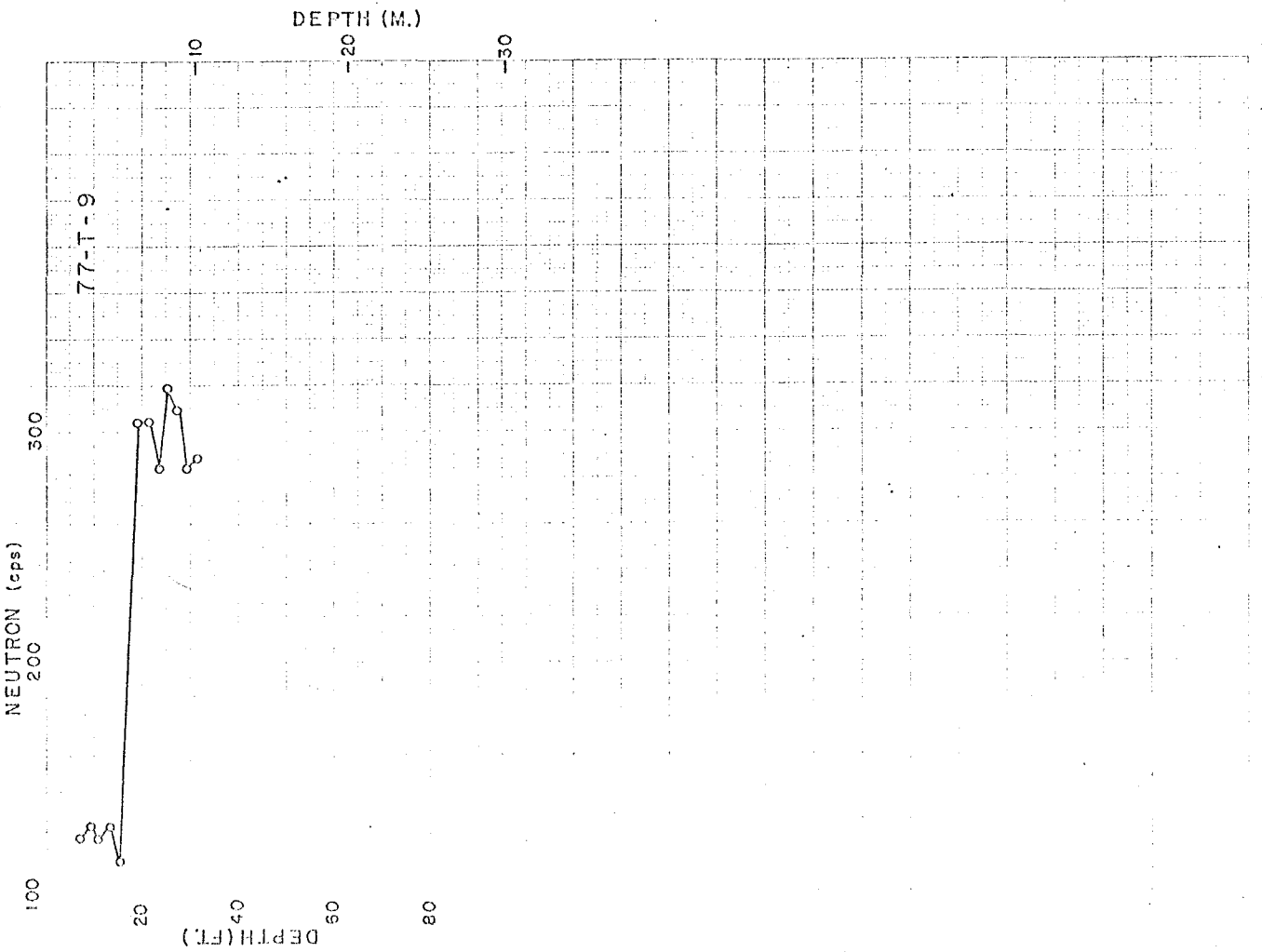

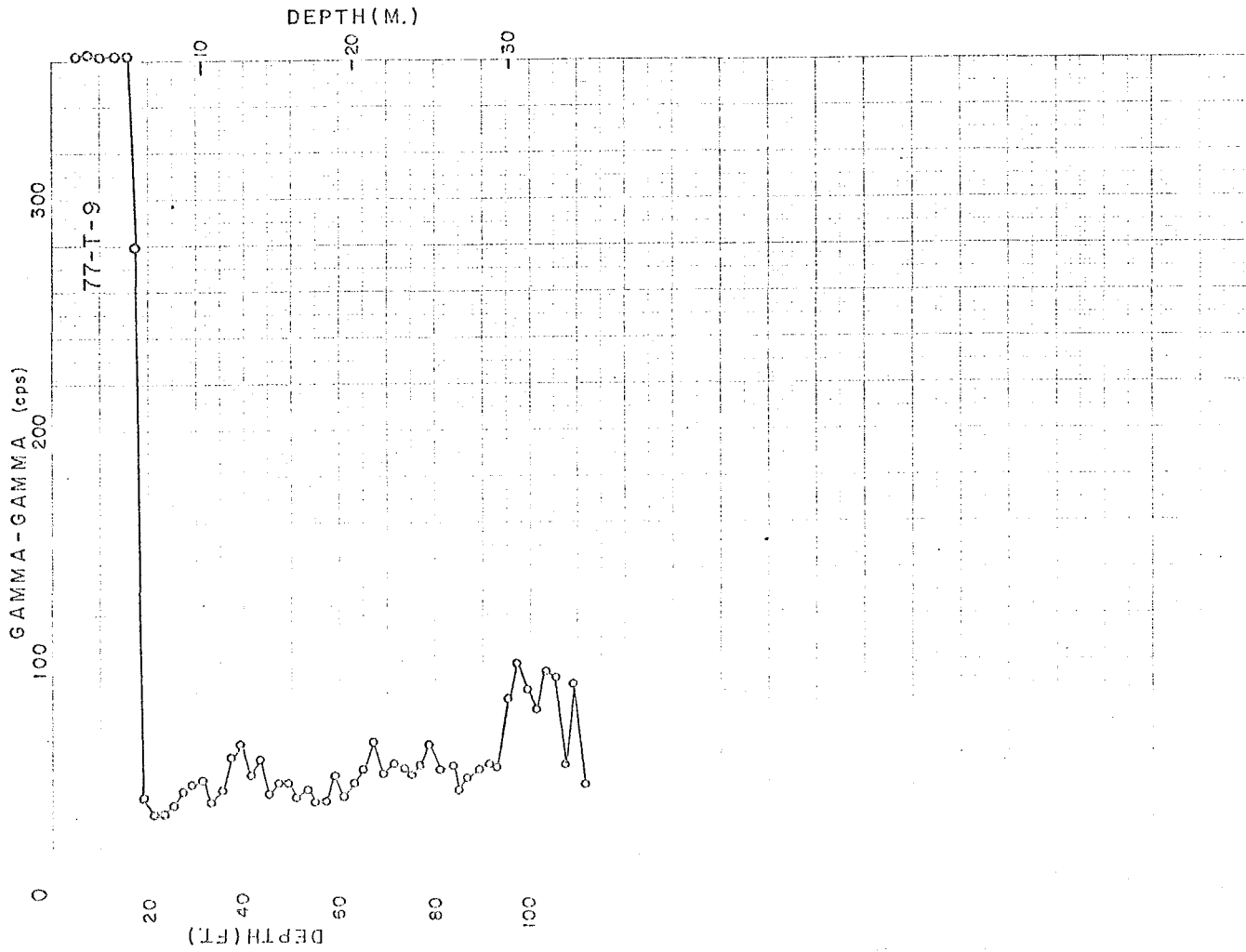

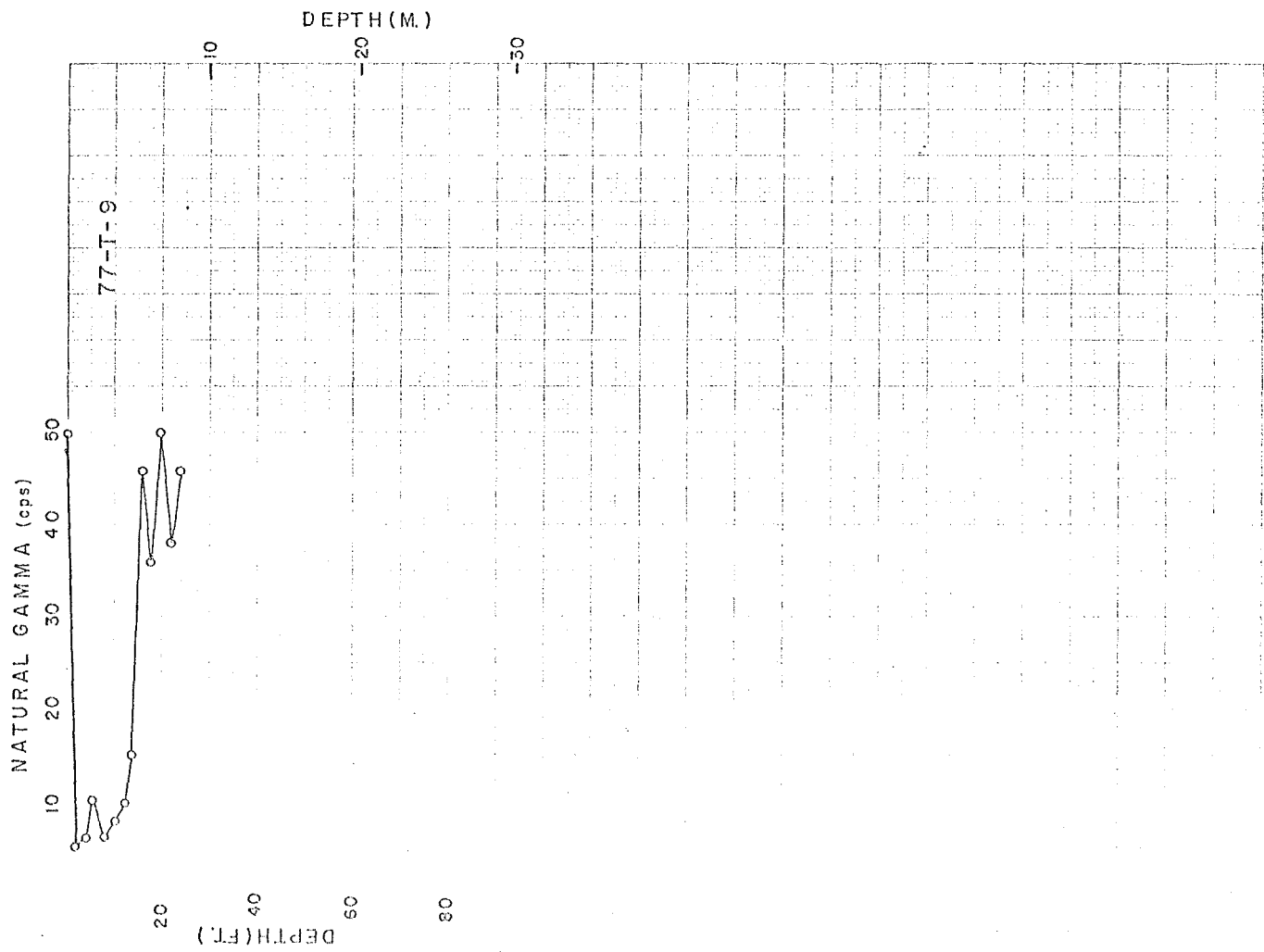

DRILLING RATE (MIN/METER)

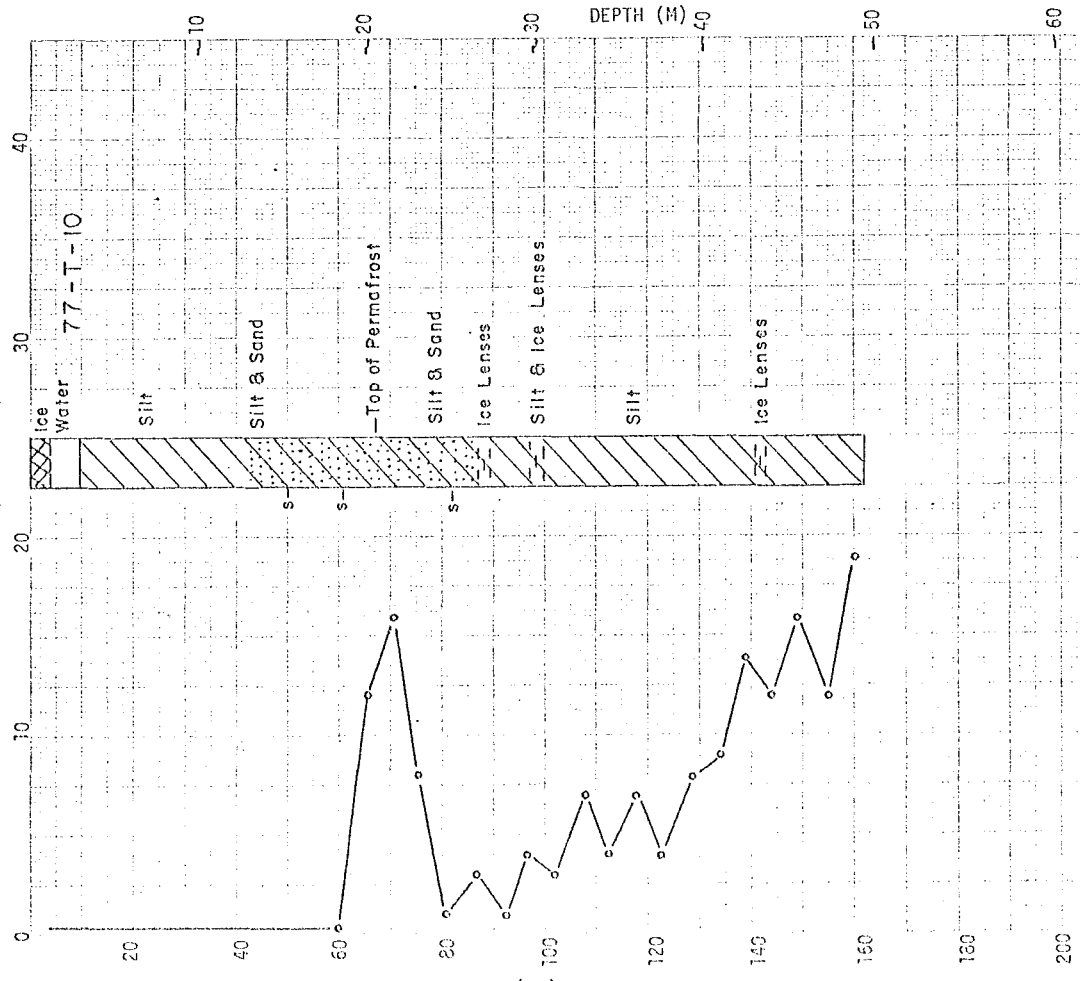

TEMPERATURE (°C)

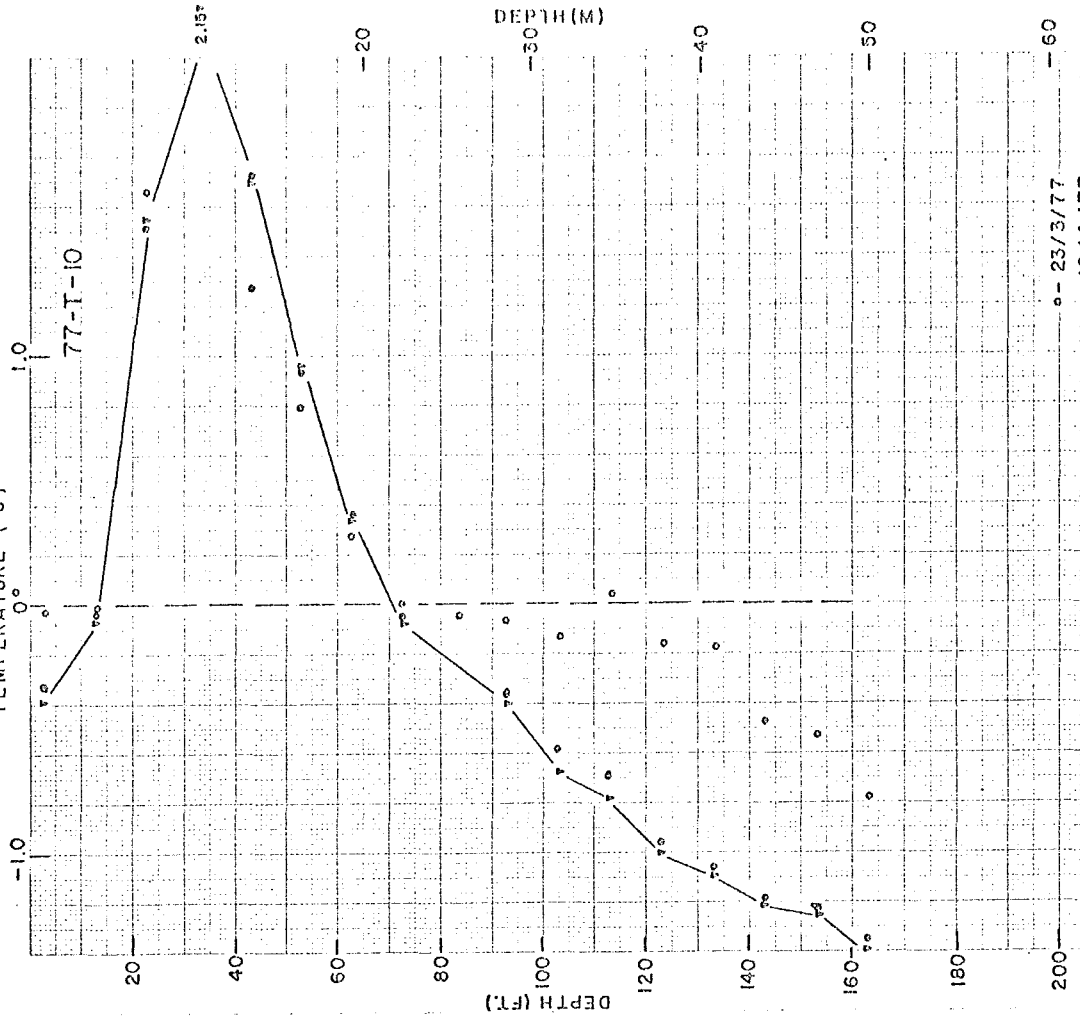

○ - 23/3/77
 ○ - 12/4/77
 ▼ - 30/4/77

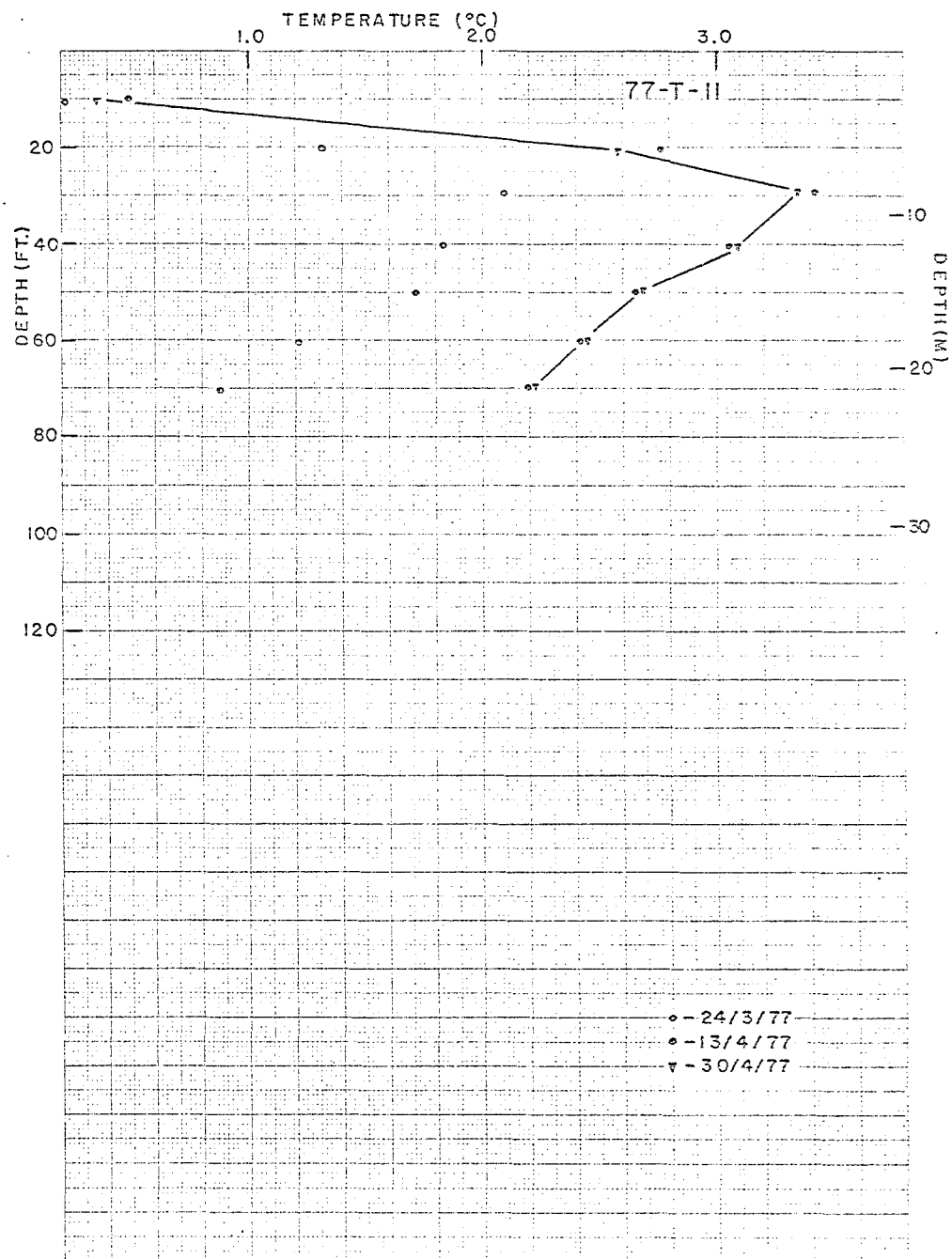
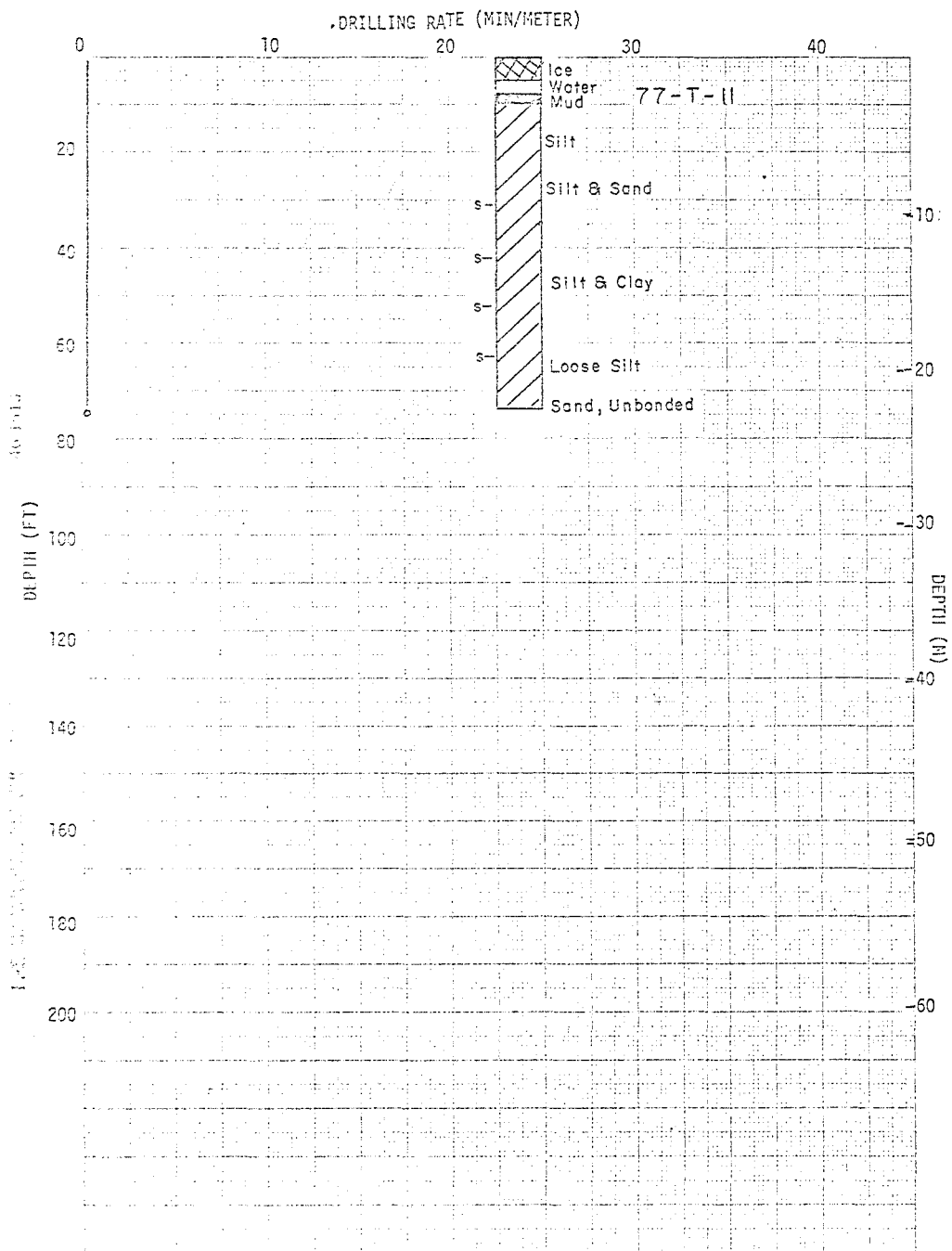

46 1513

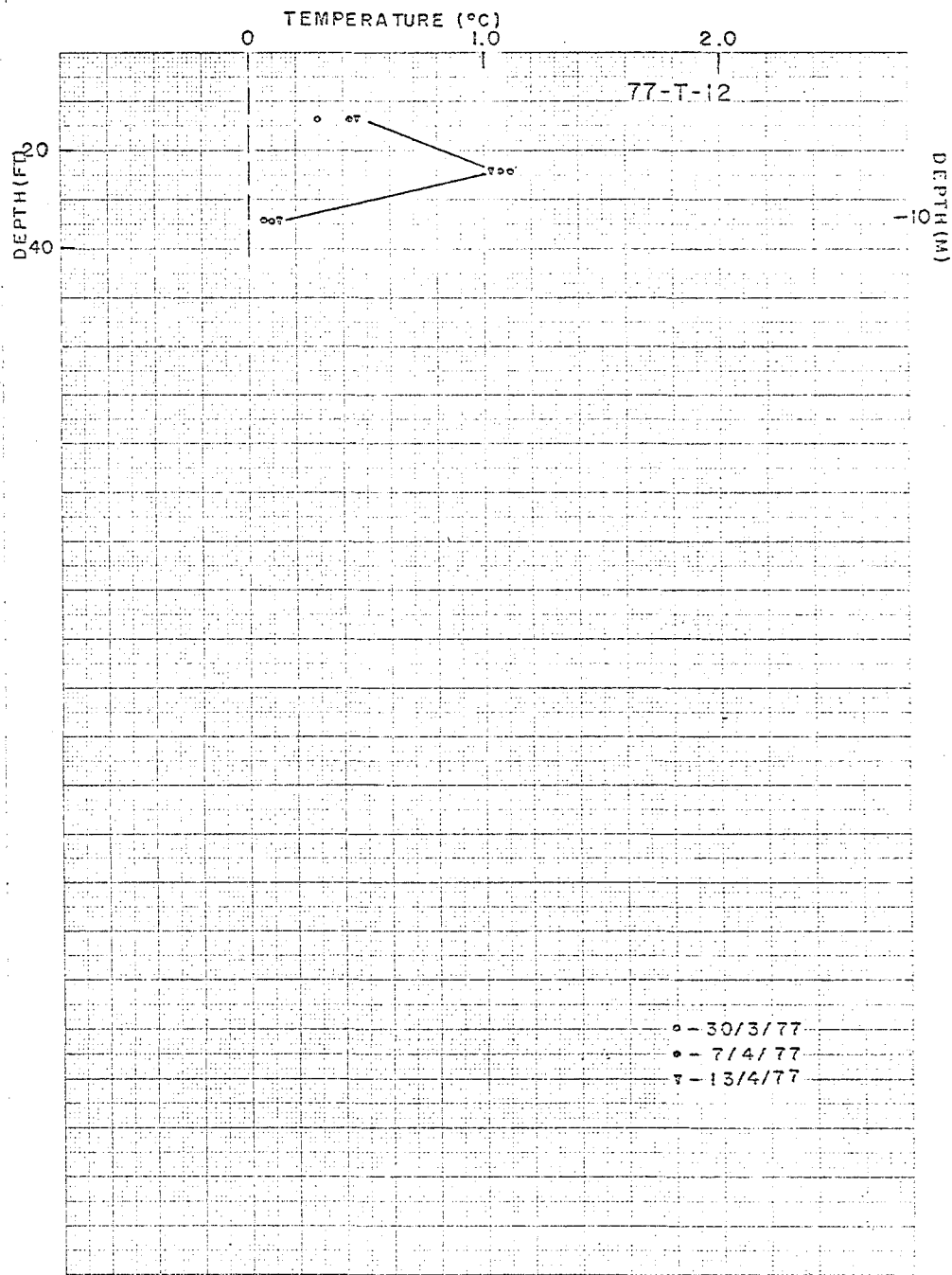
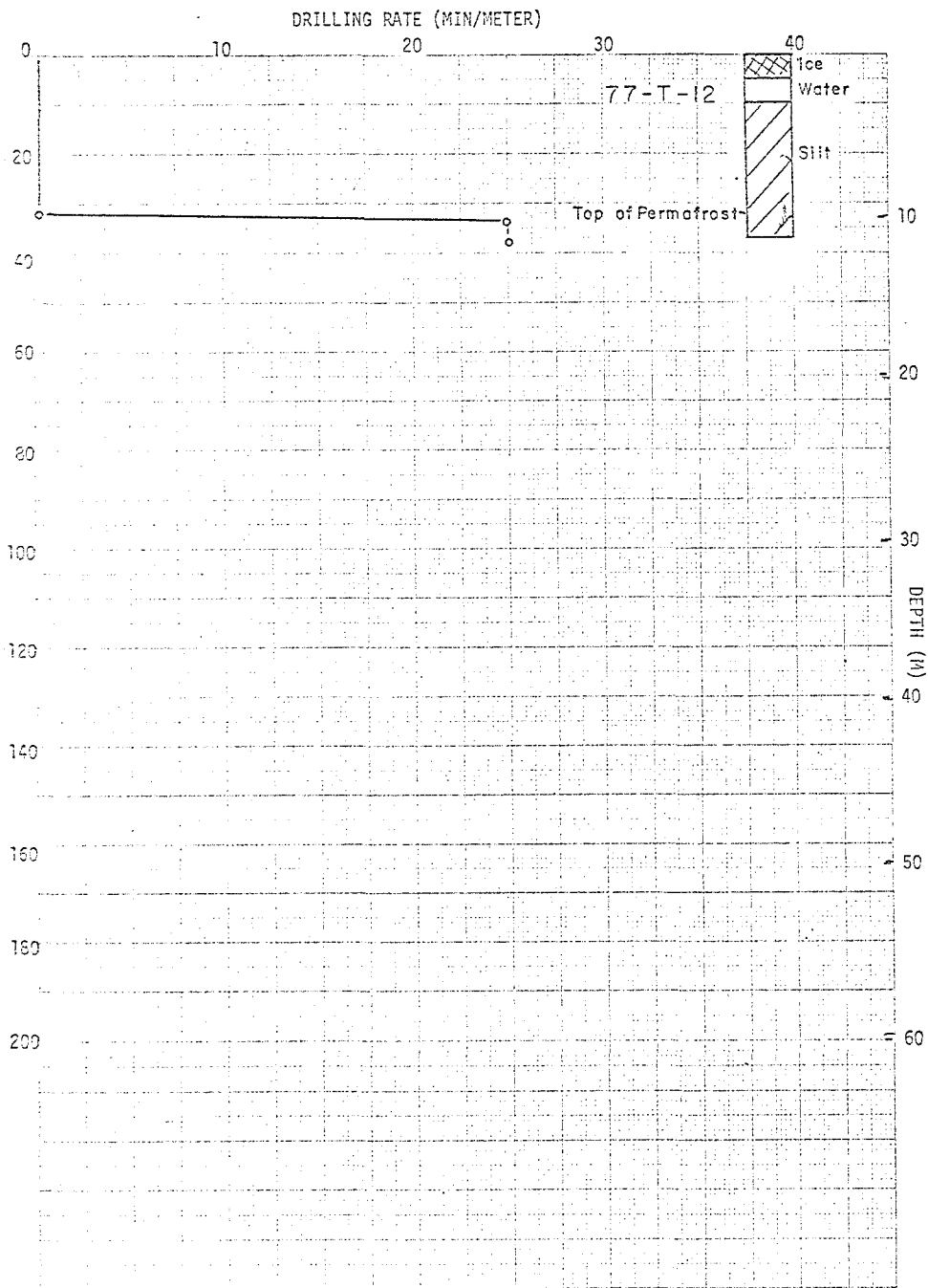

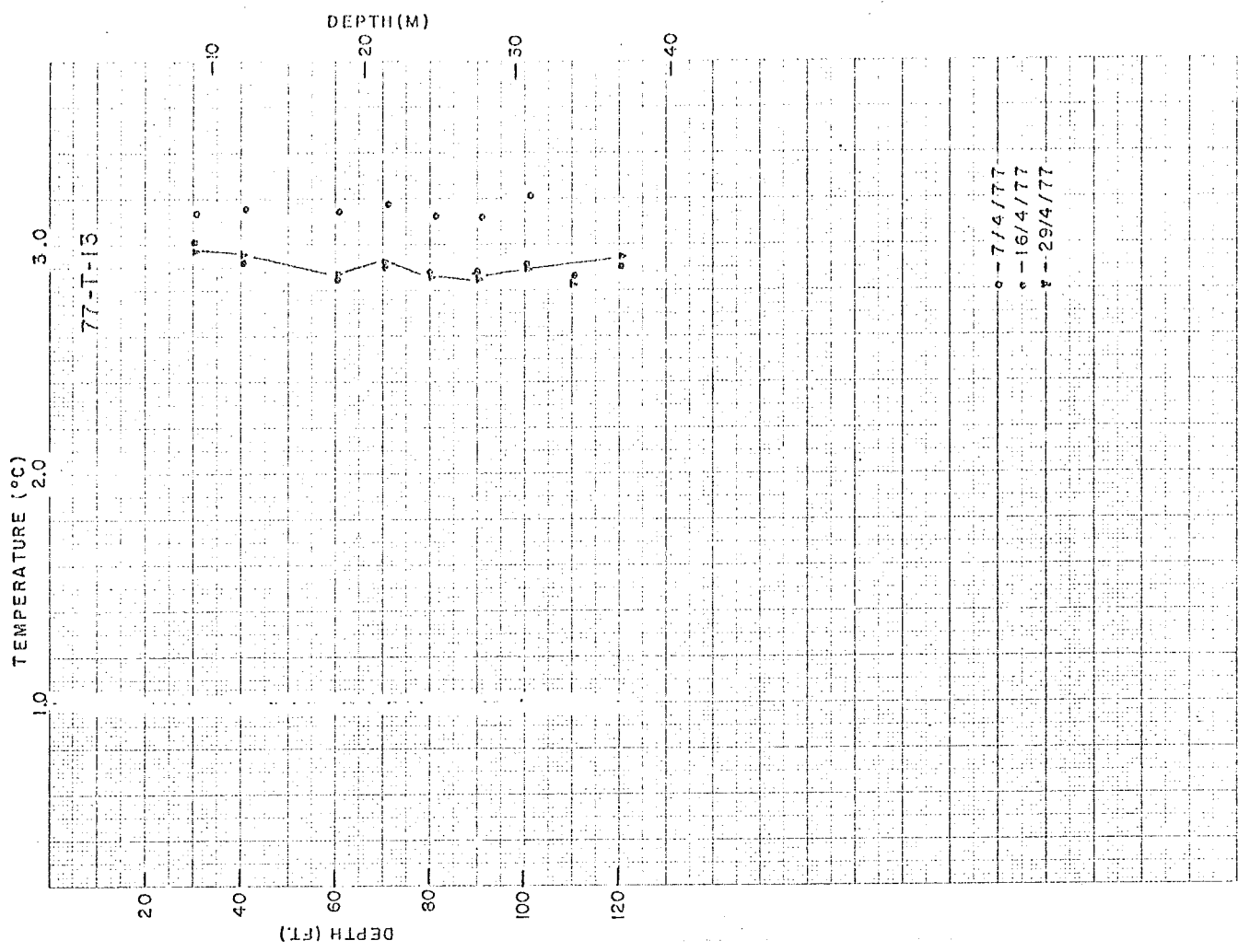
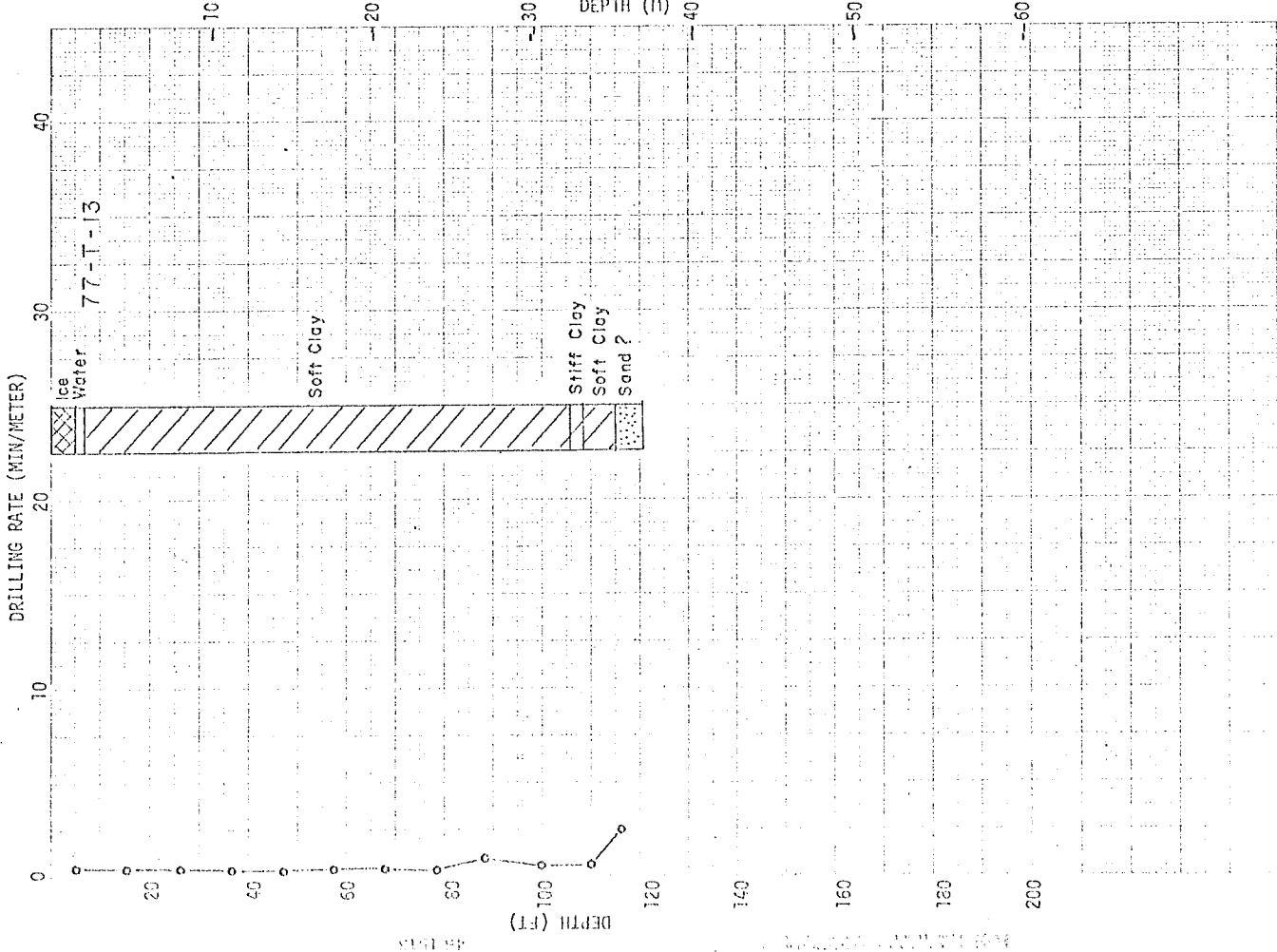

7/4/77
16/4/77
29/4/77

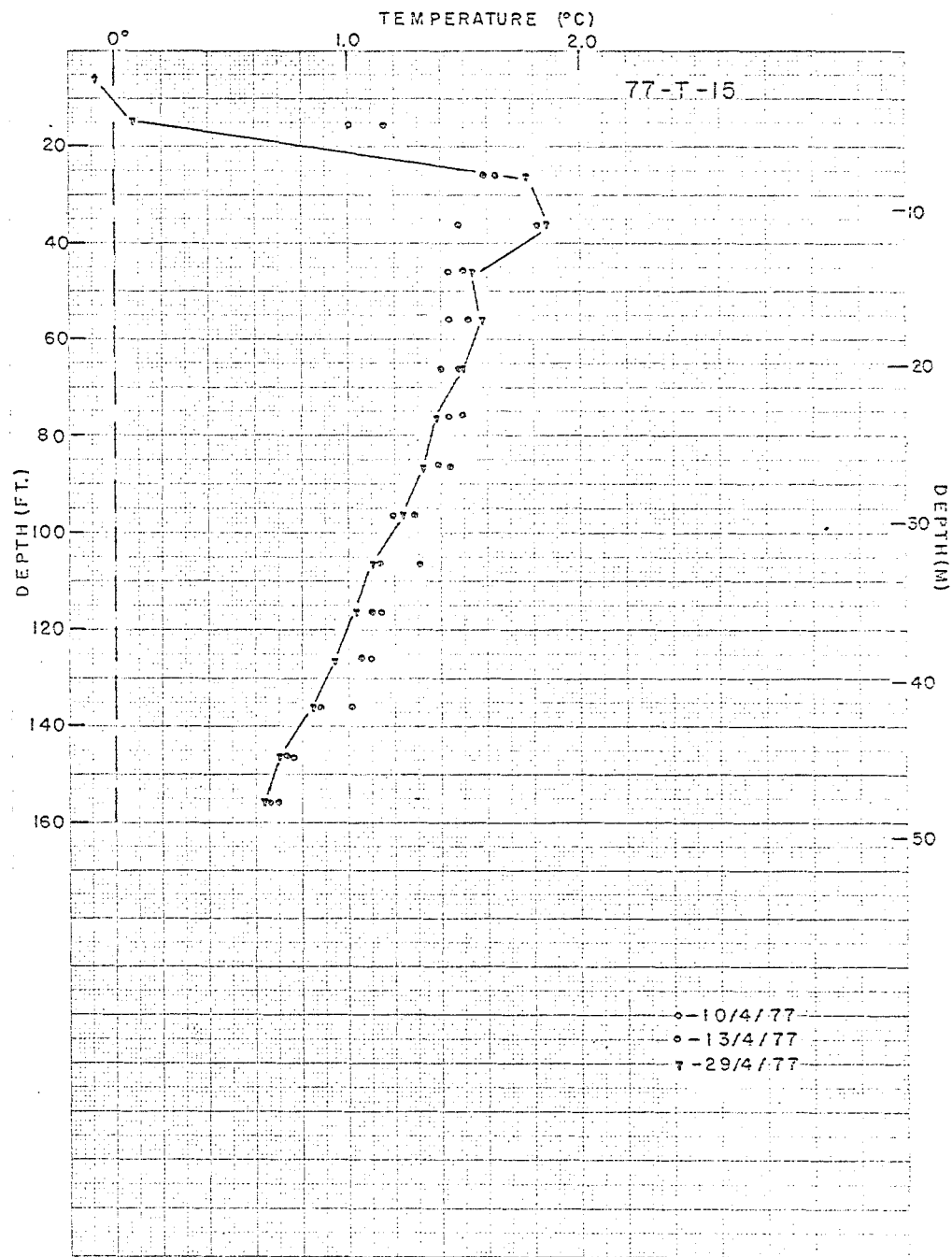
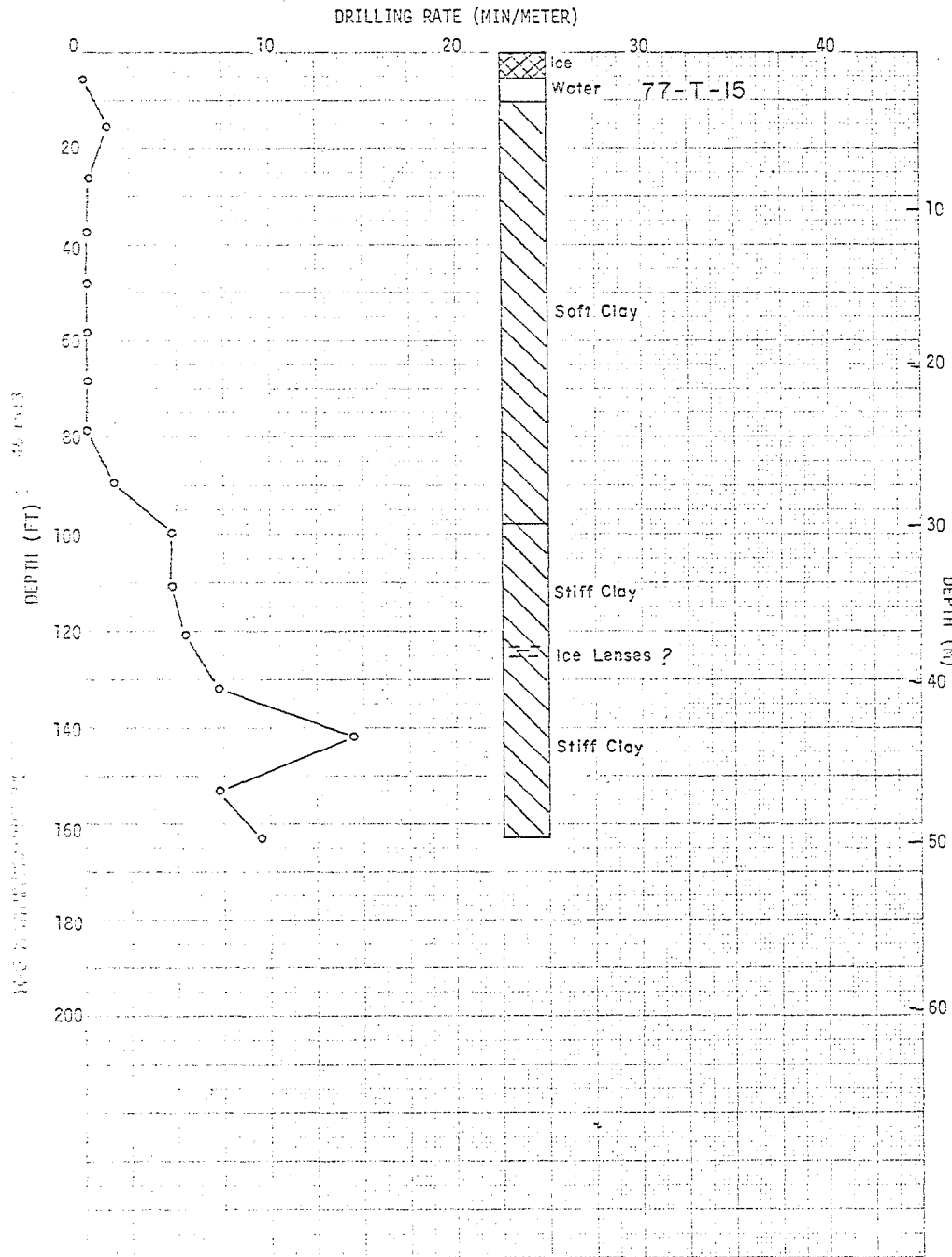

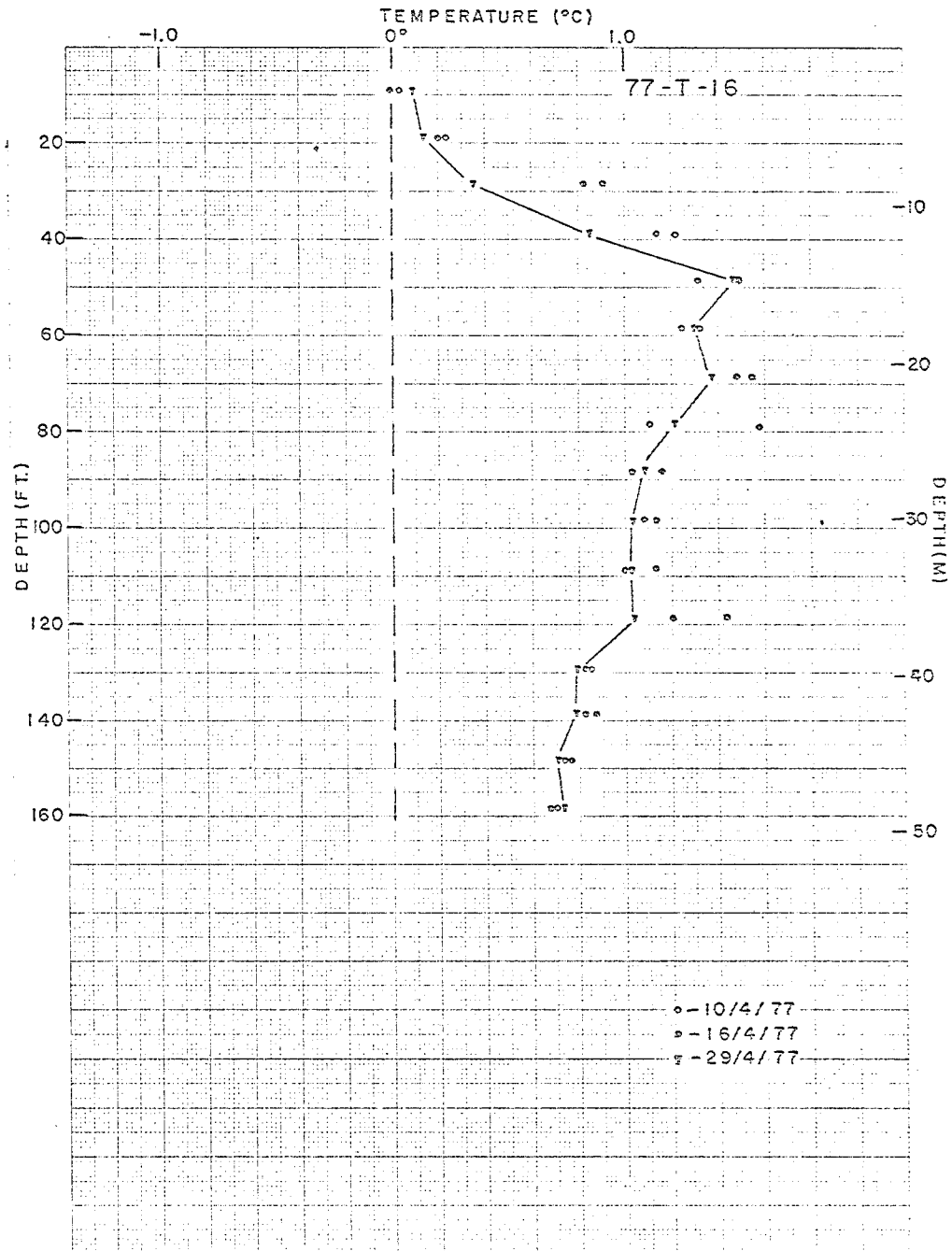
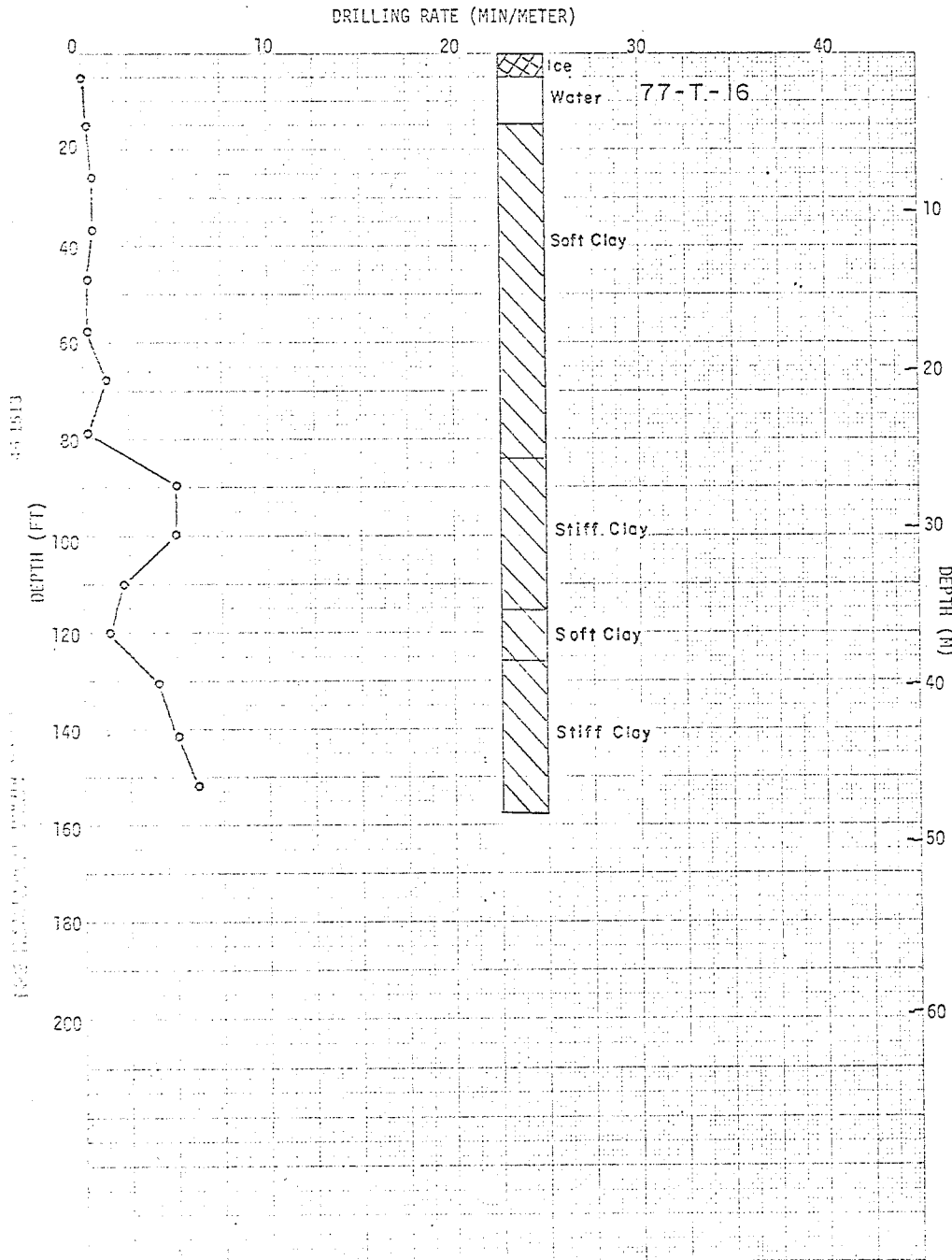

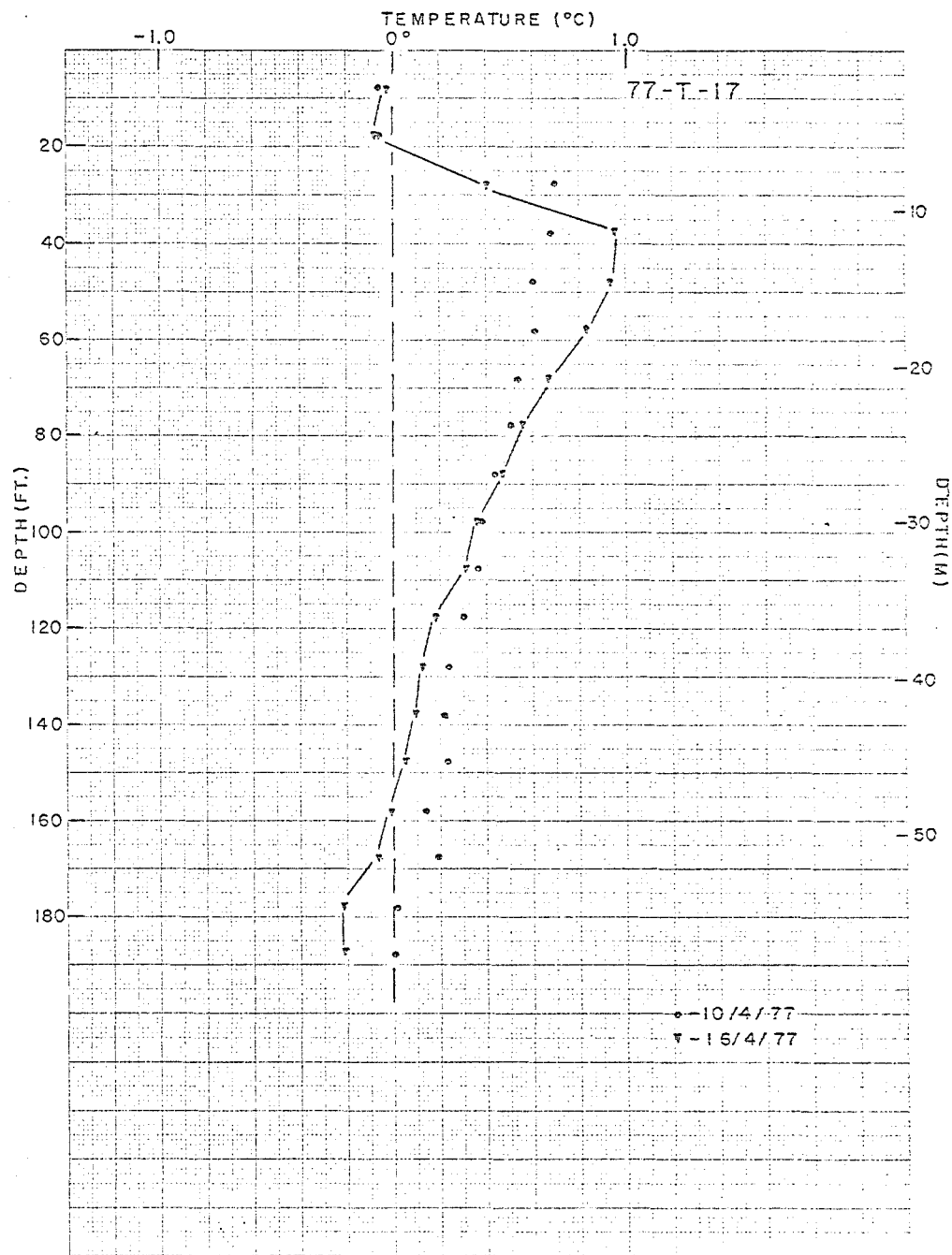
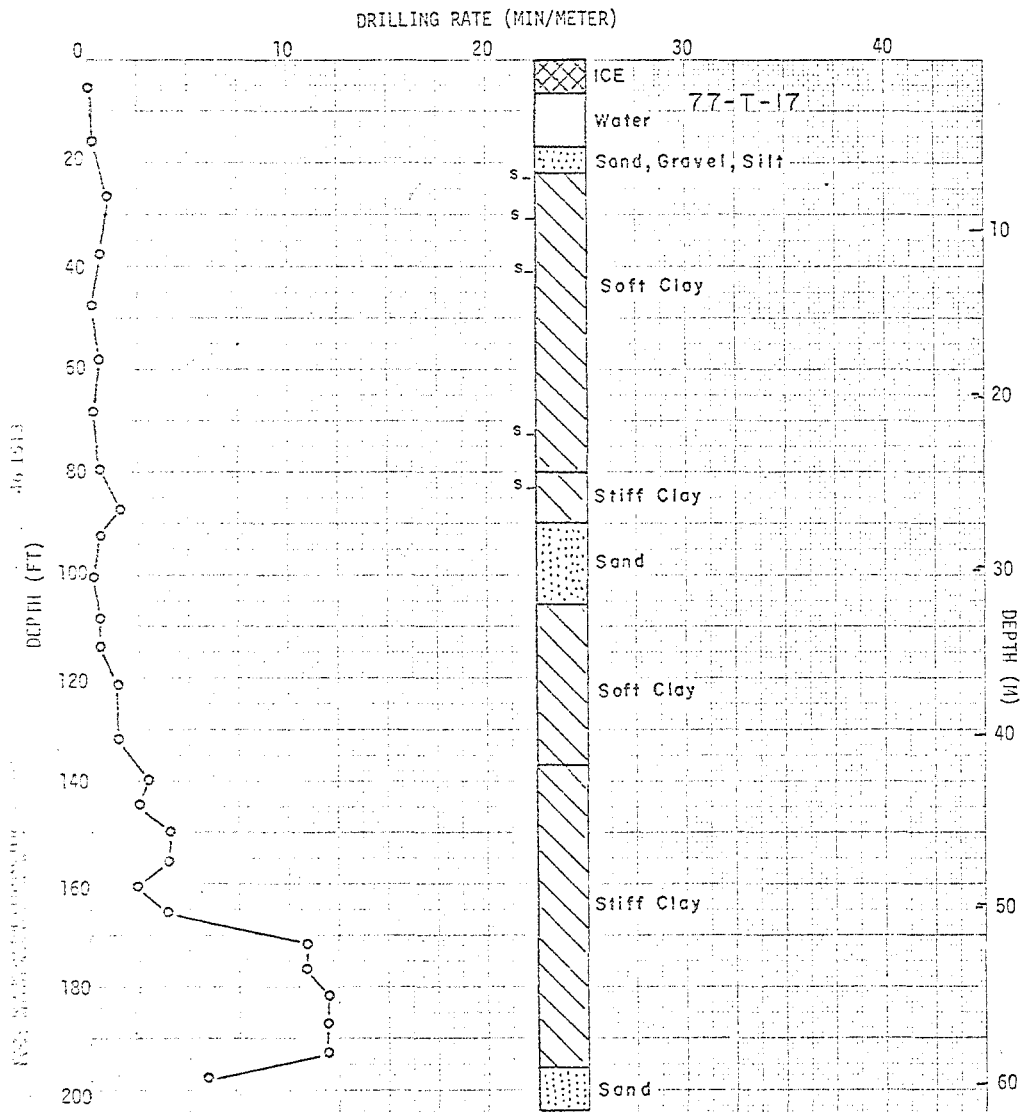

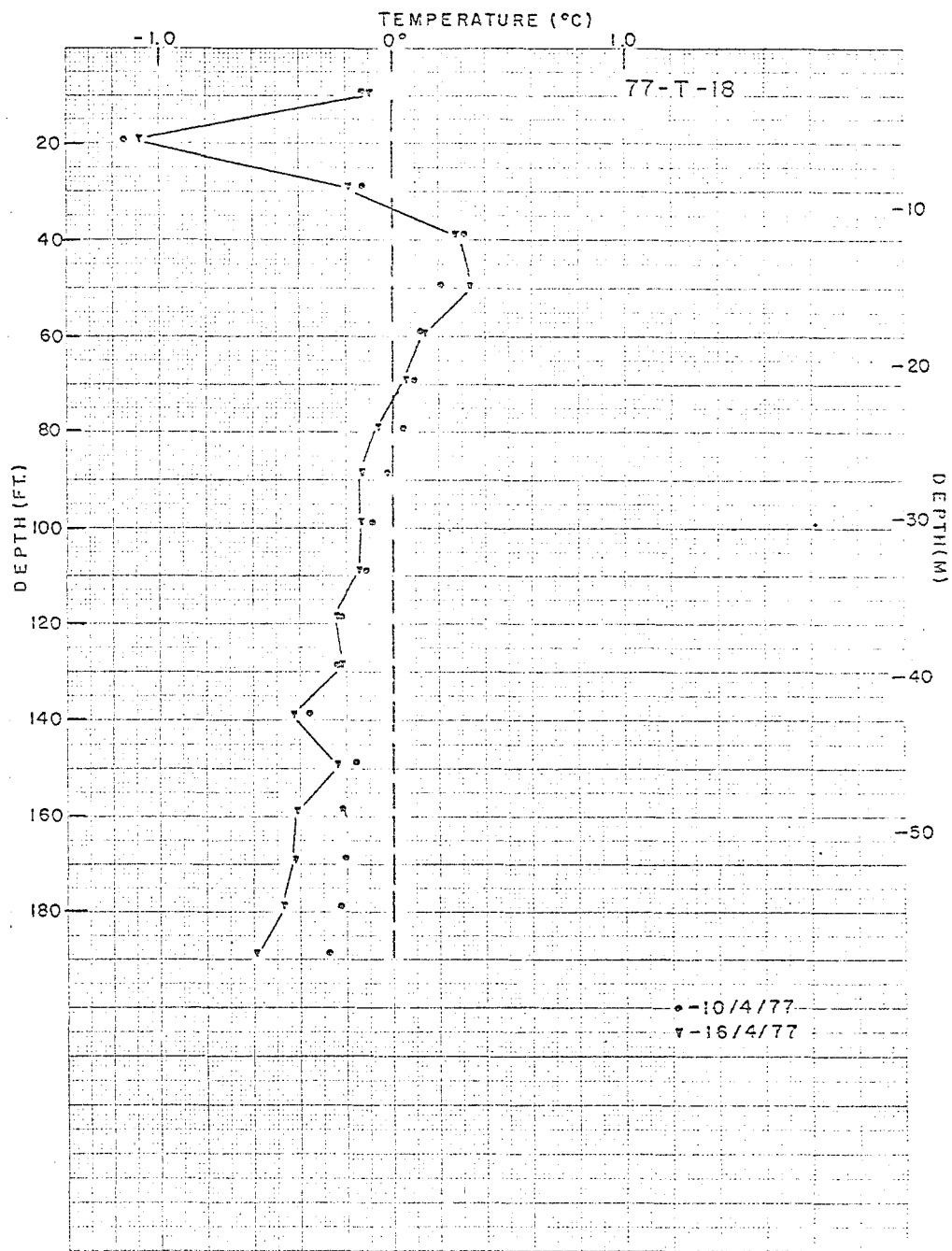
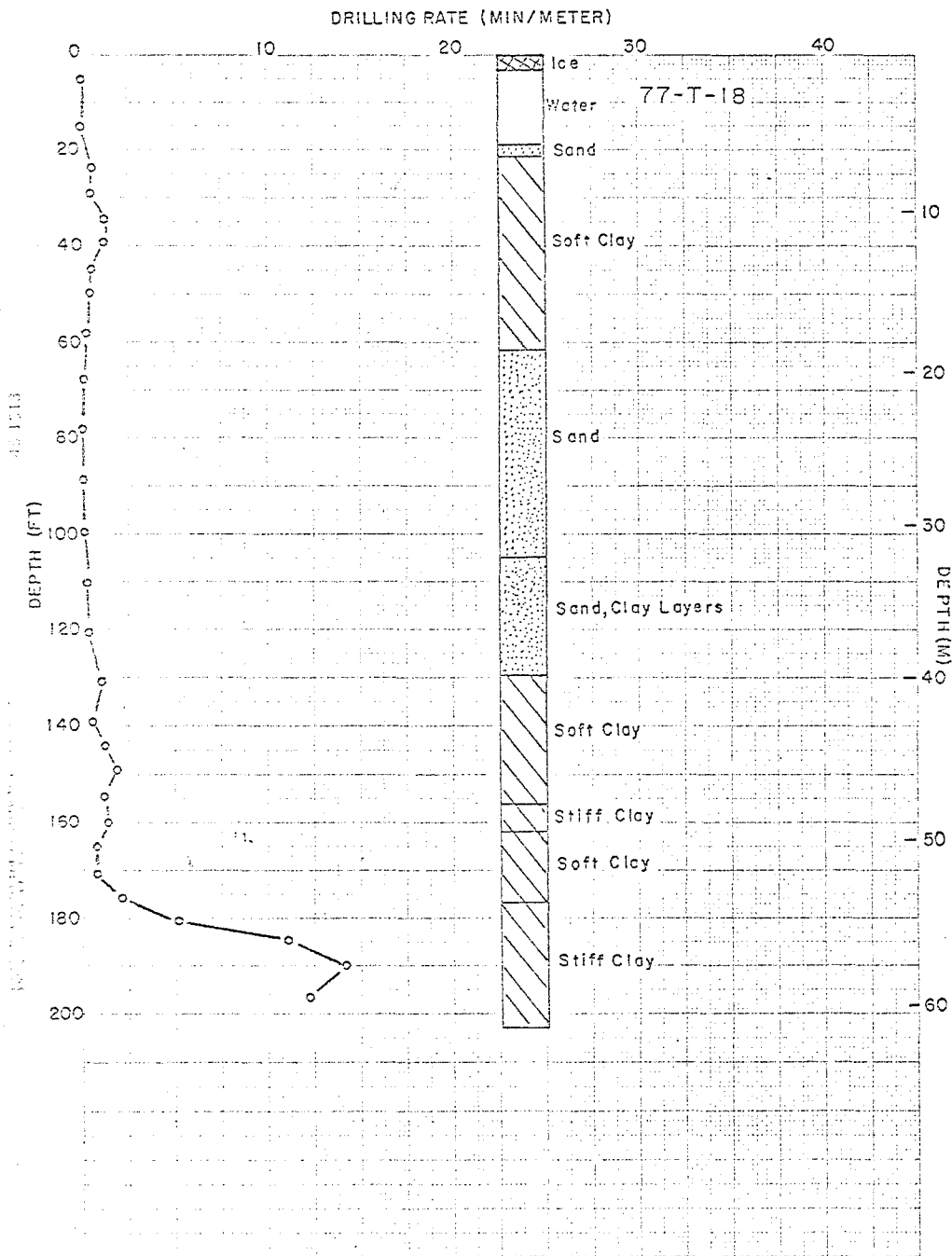

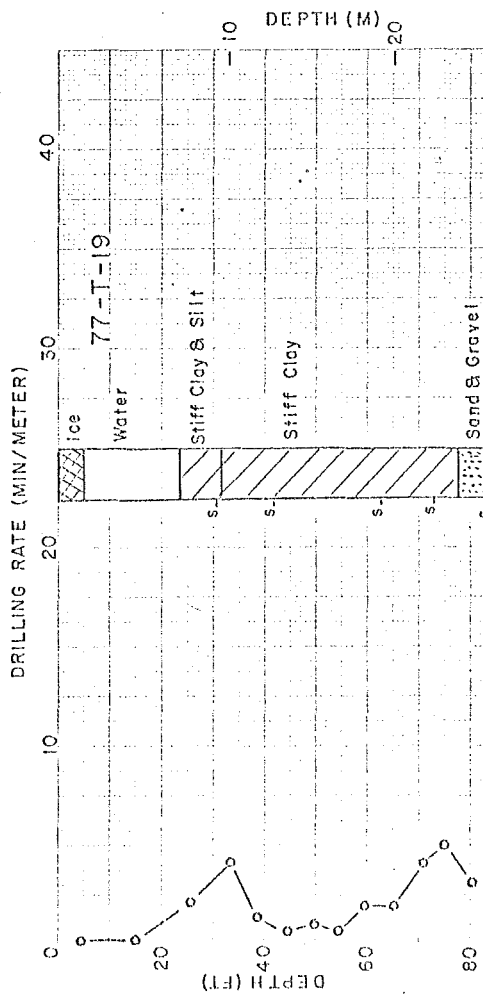
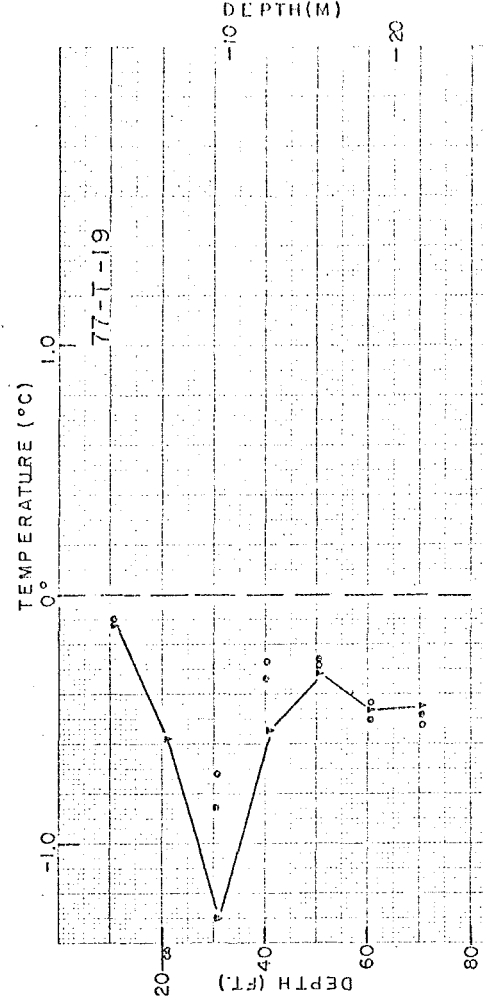

° - 10/4/77
 ° - 16/4/77
 * - 29/4/77

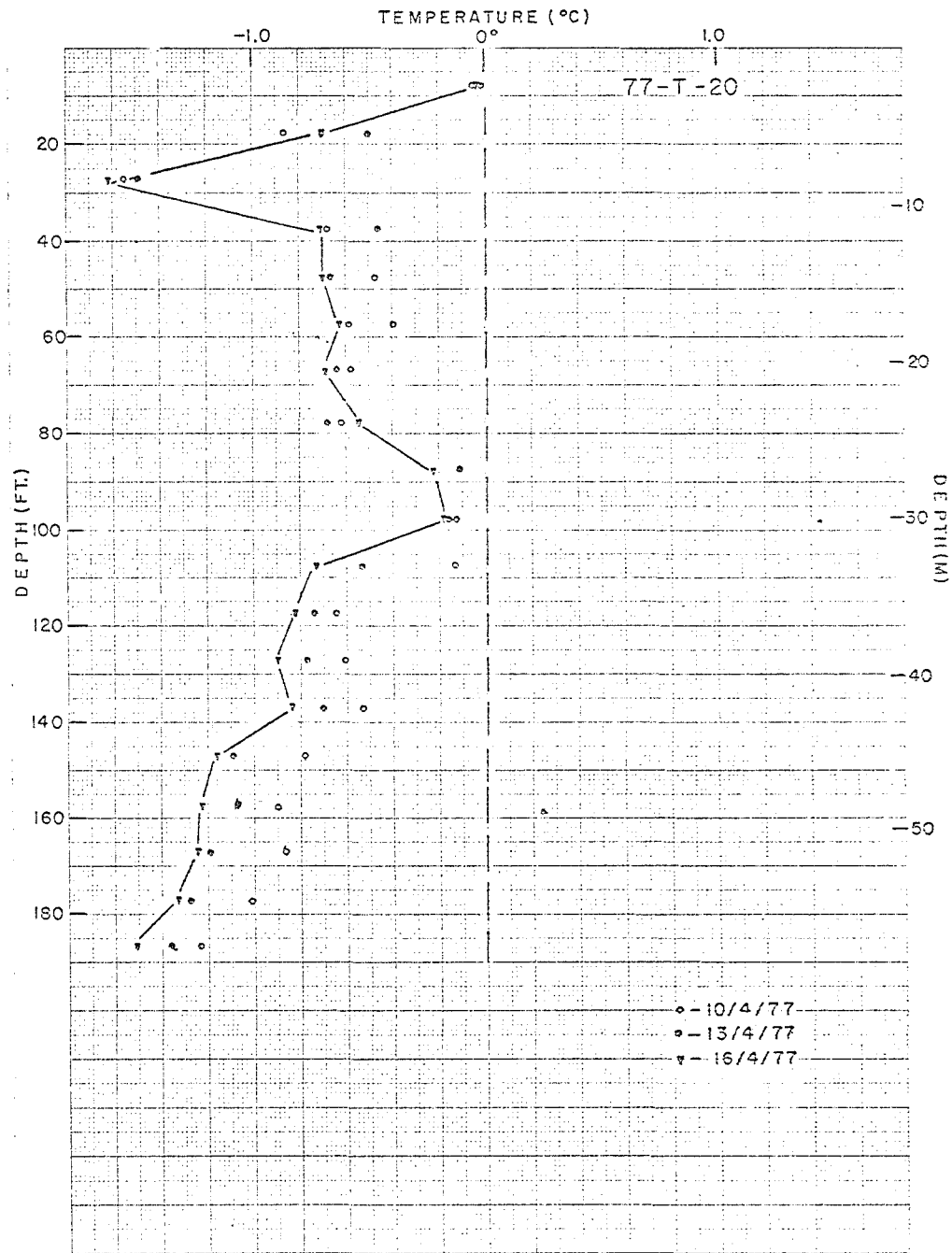
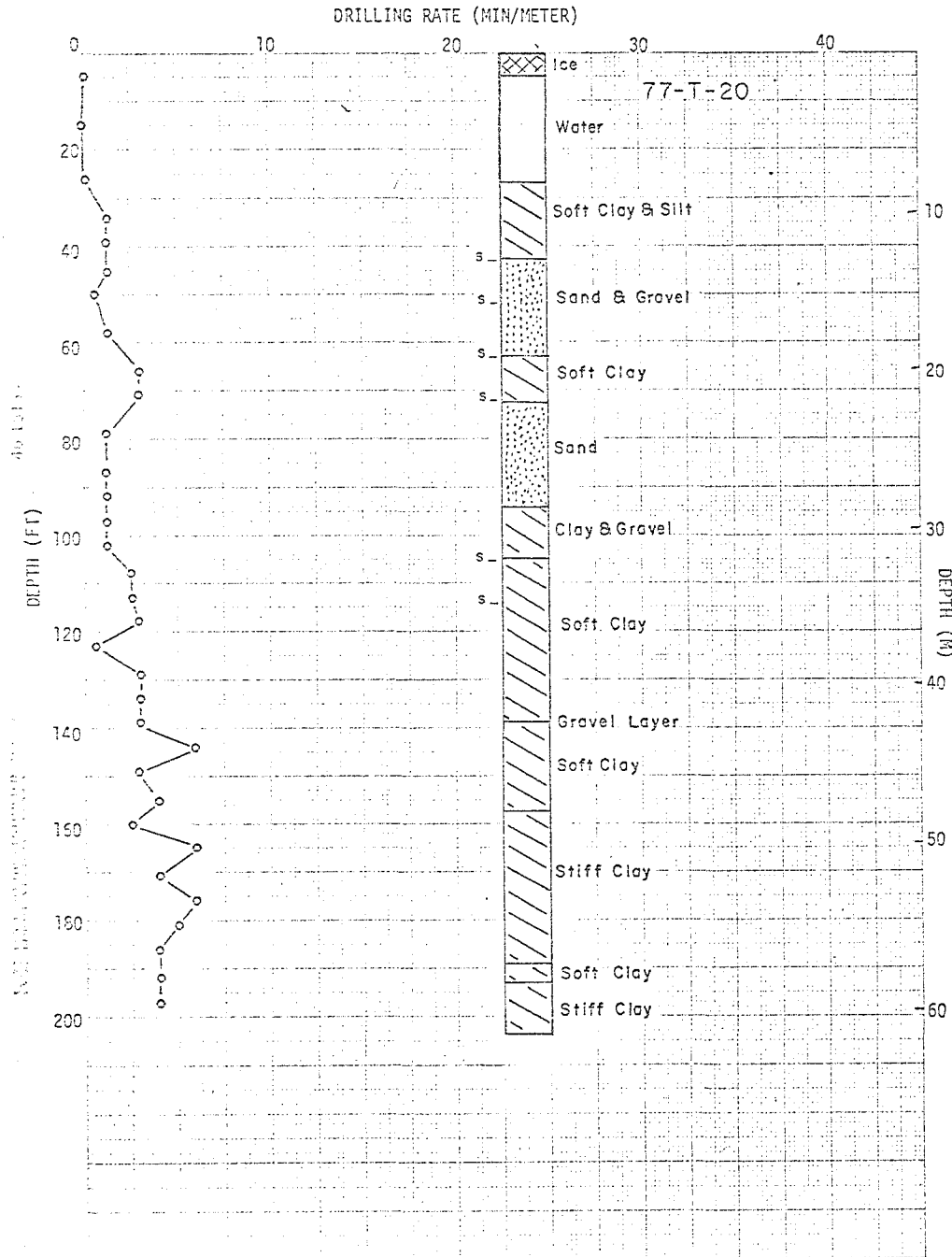

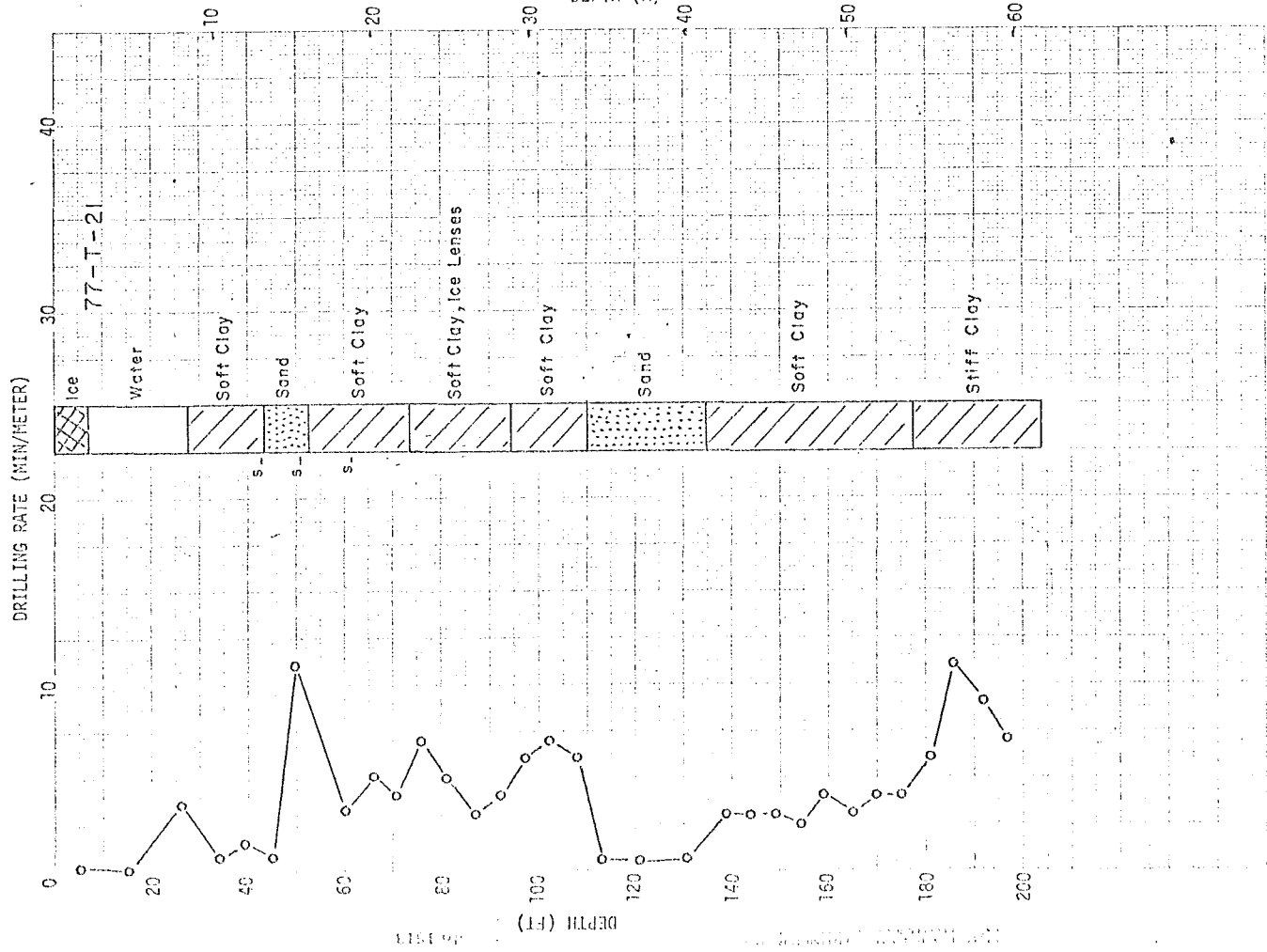
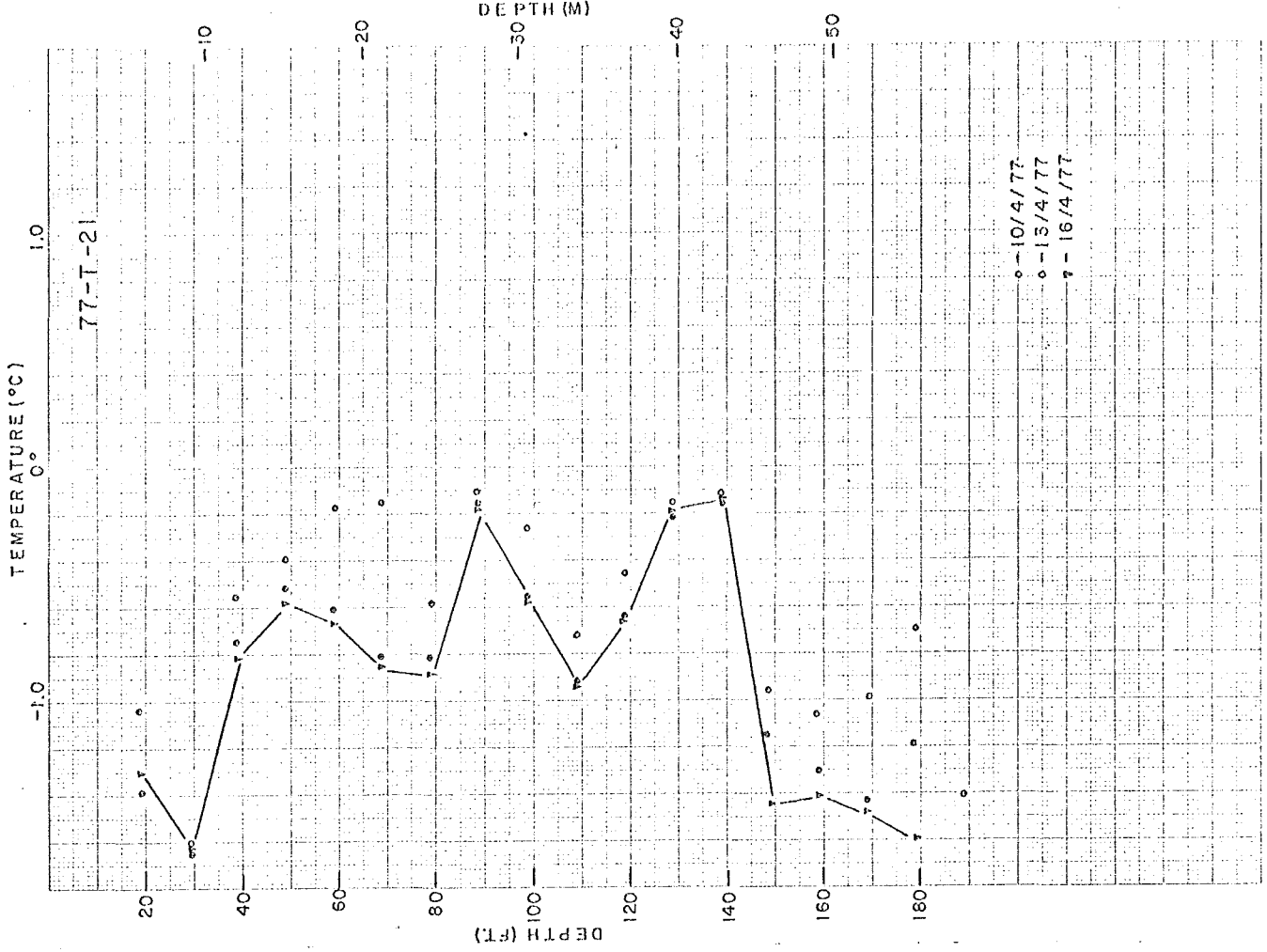

APPENDIX B

Drilling Logs for Boreholes

ENERGY, MINES AND RESOURCES

JET-DRILLING LOG

HOLE NO. 77-T-2 AREA SHALLOW BAY DATE March 15, 1977LINE (A)
4000' from
shoreLAT. 68° 51.09' WATER DEPTH + ICE 11'LONG. 35° 57.77' ICE THICKNESS 5'

PIPE L	DEPTH	TIME MIN	PRESS	REMARKS
1	10.5		-	Start 11:00 a.m.
2	21.0	5	-	Mud
3	31.5	5	-	Mud, some sand and silt
4	42.0	5	-	Mud
5	52.5	5	-	Silt, hard layer (permafrost) at 49.5'
6	63.0	30	-	Ice lenses, silt, 11:30 hose break at 53', start 11:30, hose broke 11:50
7	73.5	40	150	start 12:35
8	84.0	30	150	Stop 13:40 hose repair, restart 14:35 new hose
9	94.5	35	170	Ice lenses sample 72.5' clay wood chips, shell
10	105.0	25	160	Faster Drilling
11	115.5	25	160	Ice lenses
12	126.0	25	160	Clay, ice lenses
13	136.5	35	160	Hard layer at 132.5' - 134.5' (sand?)
14	147.0	50	160	Hard drilling
15	157.5	55	160	sections require spudding
16	168.0	25	180	Easy drilling
17	178.5	25	180	
18	179	5	180	Stopped at 20:0 pipe seized at 179' sample at 179'. Installed thermister cables #151 (100') and #176 (200'). Last thermister of #151 is 10' above first thermister on #176. Top thermister on #151 is 6' above top of ice

ENERGY, MINES AND RESOURCES

JET-DRILLING LOG

HOLE NO. 77-T-3AREA SHALLOW BAYDATE MARCH 17/77

LINE (A)

LAT. _____

WATER DEPTH + ICE 12.5'5760' from
shore
200' offset
downstream
from line

LONG. _____

ICE THICKNESS 5'

PIPE L	DEPTH	TIME	PRESS	REMARKS
1	10.5	10:20	-	Start 10:20 a.m.
2	21	7		Loose silt
3	31.5	13		Stiff silt at 25' lenses of hard material, pump trouble
4	42	16	110	Good drilling, loose silt
5	52.5	5	110	Loose silt
6	63	8	110	Loose silt, sample 62.5' - silt, wood chips
7	73.5	29	75	Hard drilling (permafrost) at 66' sample 72.5' silt, sand, wo
8	84	31	100	Large ice lenses
9	94.5	22	140	
10	105	24	140	
11	115.5	26	150	
12	126	24	U.S.	Large ice lenses, pump pressure increased
13	136.5	26	U.S.	Some ice lenses
14	147	31	U.S.	
15	157.5	39	170	Ice lenses, hard drilling in upper section
				Stopped at 3:15
				Installed 140' plastic pipe
				Pulled steel pipe
				Ran seismic and radioactive logs
				Installed thermister cable # 178
				Top thermister 46' below surface of ice

ENERGY, MINES AND RESOURCES

JET-DRILLING LOG

HOLE NO. 77-T-6 AREA SHALLOW BAY DATE MARCH 21/77
 LAT. _____ WATER DEPTH + ICE 6 feet
 LONG. _____ ICE THICKNESS 4.5 feet

LINE (A)
 11550' from
 shore
 offset 300'
 north from
 line

PIPE L	DEPTH	TIME	PRESS	REMARKS
10.5	10.5	1 min		Silt - starting time: 12:26
10.5	21	1 min		Silt
10.5	31.5	2 min	PRESSURE GAUGE NOT WORKING	Silt
10.5	42	4 min 1 min		2 feet into section hit harder layer (1 foot)
10.5	52.5	1 min		Sample (fine sand and silt) 77-T-6 (5)
10.5	63	2 min		Sample (clayey silt) 77-T-6 (6)
10.5	73.5	1 min		Silt
10.5	84	1 min		Sample (clay) 77-T-6 (8)
10.5	94.5	5 min 5 min		hit permafrost at 87 feet - gradual boundary probably ice lenses above it
10.5	10.5	10 min 15 min		-
10.5	115.5	10 min 9 min		-
10.5	126	16 min 12 min		Ice lenses 6 feet into section
10.5	136.5	25 min 14 min	Very slow rate for first few feet	
10.5	146	27 min 17 min	1 foot of pipe is above surface - installed cable # 179 (200') - first thermister is 58 feet below surface	
				Stopped drilling: 19:32

ENERGY, MINES AND RESOURCES

JET-DRILLING LOG

HOLE NO. 77-T-9AREA SHALLOW BAYDATE MARCH 25/77LINE B
4000' from
shore

LAT. _____

WATER DEPTH + ICE 13.5

LONG. _____

ICE THICKNESS 5'

PIPE L	DEPTH	TIME	PRESS	REMARKS
1	10.5			Start 12:40 p.m.
2	21	2		Sandy, hard
3	31.5	1		Loose silt
4	42	1		Loose silt
5	52.5	1		Loose silt
6	63	1		Permafrost at 62' from water level
7	73.5	60 54		Pipe dropped 1' at 69'
8	84	45 ---		Pump stopped
9	94.5	18 12		
10	105	14 21		Pipe jumping at 100', gas bubbles
11	115.5	20 15		Sample at 114'
12	126	20 17		
13	136.6	18 22		
14	147	27 34		
15		11		Suction hoses frozen, stopped 21:15 p.m.
				Hole depth 147
				Installed 133' of PVC casing
				Pulled steel pipe
				Installed 2.5 gal diesel in casing
				Ran seismic, - and neutron-gamma tools
				Installed thermister cable #172
				Top thermister is 19.5' below ice level

ENERGY, MINES AND RESOURCES

JET-DRILLING LOG

HOLE NO. 77-T-10

AREA SHALLOW BAY
line B - 6000 feet

DATE MARCH 26/77

LAT. _____

WATER DEPTH + ICE 9.5 feet

LONG. _____

ICE THICKNESS 4 feet

PIPE L	DEPTH	TIME	PRESS	REMARKS
				Started drilling 13:10
10.5	10.5			Human pressure
10.5	21	1 min		Water + 1 foot. silt
10.5	31.5	1 min	PRESSURE GAUGE NOT WORKING	Silt none
10.5	42	1 min		Silt none
10.5	52.5	1 min		Sample: fine silty sand at 5.05 ft none
10.5	63	1 min		Sample: fine silty sand at 61 ft none
10.5	73.5	19 min 25 min		Hit permafrost at 67 ft 10 min in
10.5	84	13 min 1.5 min		Sample: finer silty sand at 82 ft second 1
10.5	94.5	5 min 2 min		Ice lenses started around mid 5 min
10.5	105	6 min 5 min		section lenses section
10.5	115.5	11 min 5 min		none
10.5	126	11 min 7 min		none
10.5	136.5	12 min 14 min	none	
10.5	147	22 min 19 min	Some lenses 10 min in	
10.5	157.5	26 min 19 min	last 1/2	
10.5	161.25	30 min	Pipe would not penetrate further last 4 min	
				last 23 min
				Installed 200' cable #166 & taped on 100'
				cable #148 . . . last thermistor of 148
				is 10 ft from first of 166 17 thermistors
				in hole - first is 3 ft from surface
				Stopped drilling: 19:30

ENERGY, MINES AND RESOURCES

JET-DRILLING LOG

HOLE NO. 77-T-13 AREA Adgo J-27 DATE APRIL 5, 1977

LAT. 69° 26' 30" WATER DEPTH + ICE 5.5 feet

LONG. 135° 50' 52" ICE THICKNESS 5 feet

PIPE L	DEPTH	TIME	PRESS	REMARKS
10.5	10.5	1 min	100	Started drilling: 15:10
10.5	21	1 min	100	
10.5	31.5	1 min	100	
10.5	42	1 min	100	
10.5	52.5	1 min	100	
10.5	63	1 min	100-150	
10.5	73.5	1 min	150	
10.5	84	1 min	150-200	
10.5	94.5	3 min	150-200	
10.5	105	1.5 min	200	
10.5	115.5	2 min		Hard layer 2 feet into section 30 secs into section, pressure drop, dead stop
				moved again after V&J sat on it
				sample 114 ft - clay
				pipe seized (another day later?), pump pressure dropped
				total depth 121 feet - installed cable #160 - 31 ft to first thermistor
				Stopped drilling: 17:04

ENERGY, MINES AND RESOURCES

JET-DRILLING LOG

HOLE NO. 77-T-15 AREA 5 mi. N. of Adgo DATE APRIL 8, 1977
 LAT. 69° 30' 46" WATER DEPTH + ICE 6 feet
 LONG. 135° 54' 6" ICE THICKNESS 11/5 feet

PIPE L	DEPTH	TIME	PRESS	REMARKS
10.5	10.5			water Started drilling: 12:24
10.5	21	1 min	100	
10.5	31.5	1 min	100	
10.5	42	40 sec	100	
10.5	52.5	30 sec	100	
10.5	63	30 sec	100-120	
10.5	73.5	25 sec	100	
10.5	84	25 sec	150	
10.5	94.5	5 min	125	
10.5	105	15 min	125	4 feet (few minutes) into section pipe began to slow down drastically - relatively harder layer: permafrost? Extra human pressure, 2 people, for last 3 feet, up to 1
10.5	115.5	15 min	130-150	
10.5	126	18 min	175	
10.5	136.5	23 min	175	bouncing & jumping of pipe in this section - 2 people sitting on it most of time - ice
10.5	147	46 min	200	2 people sitting on pipe - sample tense at 146 feet: lump of very compacted clay, little water content, appear frozen
10.5	157.5	23 min	gage frozen	this section & previous were very hard going had to twist, stand on, sit on, jump on, etc pipe to get it moving. Sample 156-ft clay as before, but mostly in suspension & therefore washed away
10.5	163.5	30 min	gage frozen	No sample, but slight flow, could tell there was clay in suspension Installed 2 cables, #152 & #153 (top) first thermistor is 6 feet (bottom) below surface 16 thermistors in

Stopped drilling: 17:05

ENERGY, MINES AND RESOURCES

JET-DRILLING LOG

HOLE NO. 77-T-16 AREA Natserk South DATE APRIL 9, 1977LAT. 69° 33' 03" WATER DEPTH + ICE 5 feetLONG. 135° 55' 56" ICE THICKNESS 13 ft 10 in

PIPE L	DEPTH	TIME	PRESS Aver	REMARKS
10.5	10.5			Started drilling: 12:15
10.5	21	1 min		Hit bottom 3'4" into section
10.5	31.5	2 min	100	
10.5	42	1.5 min	120	
10.5	52.5	35 sec	105	Slight flow - no sample
10.5	63	40 sec	130	
10.5	73.5	4 min	120	
10.5	84	15 sec	135	
10.5	94.5	16 min	145	Twisting & pushing - sample at 93.5 ft: clay globs, most of it is in suspension & therefore not retained, some silt & fine sand as well
10.5	105	15 min	150	Twisting & pushing
10.5	111.5	7 min	150	Twisting & pushing - slight flow, no sample
10.5	126	5 min	155	lots of twisting & pushing - sample at 124 ft - clay as above, little retained
10.5	136.5	13 min	150	as in previous section, sample at 135.5 ft: clay
10.5	147	15 min	175	Slight flow, no sample
10.5	156	19 min	200	Twisting & pushing sample at 156 ft - clay, burping up hole because of gas which burned when lit.
				Installed 2 cables : #164 bottom
				#165 top
				16 thermistors below surface
				17th is 1 foot above
				Stopped drilling: 15:35

ENERGY, MINES AND RESOURCES

JET-DRILLING LOG

HOLE NO. 77-T-17 AREA NETSERK + 13500' DATE APRIL 10, 1977
SOUTHLAT. 69° 35' 12"WATER DEPTH + ICE 16.5'LONG. 135° 55' 18"ICE THICKNESS 6'

PIPE L	DEPTH	TIME MIN	PRESS	REMARKS
1	10.5			
2	21	1		Start 12:18 Sample 20:5'
3	31.5	3		Sand, gravel and clay Sample 31'
4	42	2		Soft clay Sample 41'
5	52.5	1		Soft clay
6	63	2		Soft clay
7	73.5	1		Soft clay, Sample 73'
8	84	2		Soft clay, hard layer at 82' Sample 83'
9	94.5	3 1		Stiff clay, last half drilled fast
10	105	1		Fast drilling, sand?
11	115.5	1 1		Fast drilling, hard lenses, sand?
12	126	1		Soft clay
13	136.5	5		Soft clay
14	147	5		Stiff clay
15	157.5	5 4		Stiff clay
16	168	6 6		Stiff clay, second half very stiff, ice bonding?
17	178.5	4 5		Very stiff clay
18	189	18 17		Very stiff clay
19	199.5	20 20		Pipe dropped last 31 - sand? Stiff clay, increased pump pressure, gas bubbles
20	204	19 9		Pipe dropped - sand? Bubbles flared stopped 4:23 p.m. Installed thermistor cables #162 (bottom) & #168 (top) Top thermistor is 2' above the ice surface

ENERGY, MINES AND RESOURCES

JET-DRILLING LOG

HOLE NO. 77-T-18AREA NETSERK
+ 27000'DATE APRIL 9, 1977LAT. 69° 37' 24"WATER DEPTH + ICE 20'LONG. 135° 54' 48"ICE THICKNESS 4.5'

PIPE L	DEPTH	TIME	PRESS	REMARKS
1	10.5			
2	21.0			Start 11:27 a.m.
3	31.5	1 1		Gravel and sand on bottom 1' soft clay
4	42	2 2		Silt and clay Sample 41'
5	52.5	1 1		Soft clay
6	63	1		Soft clay Sample 62'
7	73.5	30 sec		Sand, saline water Sample 72.5'
8	84	30 sec		Sand
9	94.5	30 sec		Sand
10	105	30 sec		Sand, gas bubbles
11	115.5	1		Sand, some clay stringers
12	126	1		Sand and clay lenses
13	136.5	3		Sand - upper section, clay lower half
14	147	1 2		Slay with sand, soft clay in lower half
15	157.5	3 2		Soft clay
16	168	2 1		Stiff clay in upper half soft in lower
17	178.5	1 3		Soft clay with few stiff bands
18	189	8 17		Stiff clay, gas bubbles, flared
19	199.5	23 19		Very stiff clay, ice-bonded
20	204			Finish 2:08 p.m.
				Installed thermistor cable #159 (bottom) and #158 (top). Top thermistor is 1' above ice level

ENERGY, MINES AND RESOURCES

JET-DRILLING LOG

HOLE NO. 77-T-20 AREA NETSERK N DATE APRIL 8, 1977
12,500'
 LAT. 69° 41' 53" WATER DEPTH + ICE 26.5'
 LONG. 135° 54' 00" ICE THICKNESS 5'

PIPE L	DEPTH	TIME	PRESS	REMARKS
1	10.5			
2	21			Start Time 12:20
3	31.5	1		Soft bottom, clay
4	42	2		Silty, stiff Sample 41'
5	52.5	2		
		1		Sand gravel, binding pipe Sample 51.5'
6	63	4		Gravel or ice lensing, sand, silt Sample 62.5'
7	73.5	5		Soft clay
8	84	4		Fast drilling, sand?
9	94.5	2		Fast drilling, sand & gravel?
10	105	2		Clay with gravel Sample 104'
11	115.5	4		Soft clay
12	126	5		Clay, soft
13	136.5	1		
		5		Soft clay
14	147	5		Soft clay, gravel lense 1' at 144'
15	157.5	10		
		7		Soft clay
16	168	4		Stiff clay, increased pump pressure
17	178.5	9		Stiff clay
18	189	6		Stiff clay
19	199.5	8		Fast drilling in upper section
		6		Soft clay, stiff clay in lower half
20	204	7		Stiff clay stopped 3:36 p.m.
				Installed thermistor cables #173 (bottom and #170 (top) Top thermistor is 2.5' above ice surface

ENERGY, MINES AND RESOURCES

JET-DRILLING LOG

HOLE NO. 77-T-21

AREA

NETSERK N
+ 25000'DATE APRIL 7, 1977LAT. 69° 43' 27"WATER DEPTH + ICE 27.5'LONG. 135° 53' 30"ICE THICKNESS 7'

PIPE L	DEPTH	TIME MIN	PRESS	REMARKS
1	10.5			
2	21			Start time 12:19 p.m.
3	31.5	11		Stiff bottom, clay soft
4	42	1 2		Clay, soft Sample 41'
5	52.5	1 17		First half fast - sand? Hard layer at 46' gravel, cobbles, broke thru at bottom
6	63	11 5		Soft clay Sample 51.5' Sample 62'
7	73.5	8 7		Soft clay
8	84	11 8		Soft clay, hard lenses (ice?)
9	94.5	5 6		Soft clay, ice lenses?
10	105	9 11		Soft clay
11	115.5	9 1		Upper half soft clay Lower half - sand, pipe dropped
12	126	2		Fast drilling, sand
13	136.5	2 5		Fast drilling - sand Last 2' went slowly
14	147	5 5		Soft clay
15	157.6	5 4		Soft clay
16	168	6 5		Soft clay
17	178.5	7 6		Soft clay
18	189	10 17		Stiff clay
19	199.5	15 12		Stiff clay
20	204			Stiff clay Stopped 4:56 p.m.
				Installed thermistor cables #175 (bottom) and #163 (top). Top thermistor is 1' above ice level

Project 730006

A. S. Judge¹, J. A. Hunter, R. L. Good, J. Cowan and G. Robb
Resource Geophysics and Geochemistry Division

In an attempt to obtain subsurface temperature data in frozen surficial materials of the Tuktoyaktuk Peninsula-Mackenzie Delta Region, we are experimenting with a water-jet drilling technique. Water jetting in permafrost is well known in placer mining and the drilling technique has been used for installing piles in Alaska and northern Canada. Our application involves the installation of thermistor cables at shallow depths in a rapid, inexpensive manner.

With a relatively small water pump connected to a 1-inch I. D. steel pipe, we drilled a number of 3-m holes in frozen and unfrozen silts, sands and gravels during August 1975. No special preparation of the drilling end of the pipe was used. In unfrozen materials drilling rates exceeded 0.5 m/min. whereas in frozen materials drilling rates were in the order of 0.2-0.3 m/min. For these experiments we used sea-water at $\approx 6^{\circ}\text{C}$ as a drilling fluid; the pump used was a WAJAX Mark 26 Centrifugal 2 stage unit capable of developing 150 psi.

Deeper drilling with this unit resulted in a hole to a depth of 20 m, limited only by lack of further drilling pipe. No appreciable change in the drilling rate was observed at depth.

To complete the preliminary experiments, a hole was drilled for a thermistor installation at the Polar Continental Shelf Project base at Tuktoyaktuk. A depth of 20 m was achieved in 55 minutes through frozen sand and silt. The drill-rods were left in place and two thermistors were installed at 8 m and 15 m within 5 minutes of drillhole completion. Temperature readings commenced 30 minutes after cable installation and temperatures were monitored for 1750 minutes. Figure 100.1 shows the return of equilibrium of the drillhole; it is apparent that a "zero curtain" persisted for the first 1000 minutes representing refreezing of the surrounding walls of the drillhole. The apparent refreezing temperature of -0.08°C rather than 0°C falls within the calibration limit of $\pm 0.1^{\circ}\text{C}$ and so the

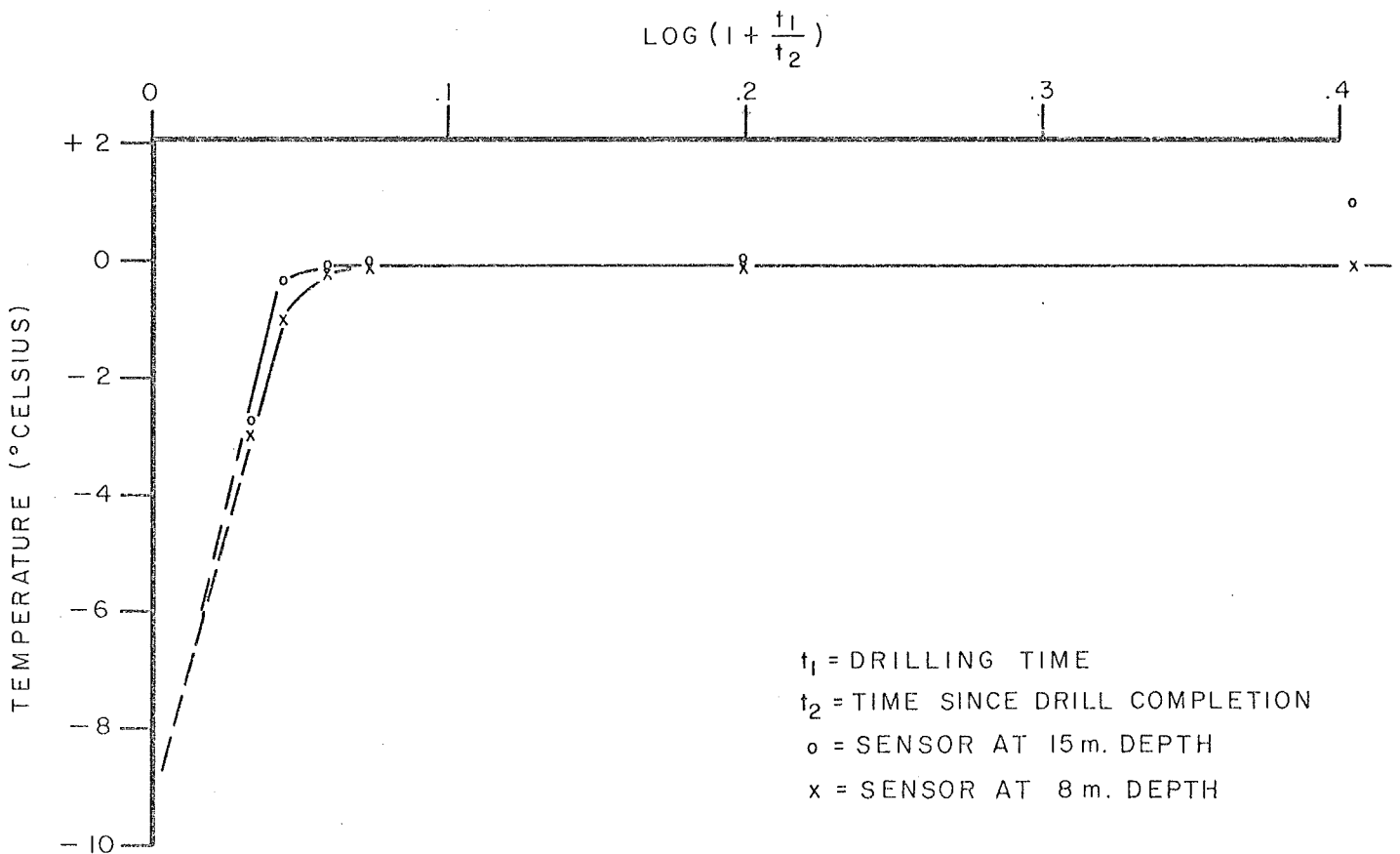

Figure 100.1.

¹Earth Physics Branch.

difference is probably not significant. Once refreezing was complete the temperatures started to fall rapidly at a rate of approximately $0.005^{\circ}\text{C min}^{-1}$. If the logarithmic return to equilibrium is a valid extrapolation, the final equilibrium temperature is -8.8°C to -9.5°C ; these results are consistent with other measurements in the Tuktoyaktuk area. If the extrapolation is valid, a very close approximation to equilibrium temperature is achieved in less than 10 days.

Measurements were again attempted a week later and both thermistor cables had failed. Attempts to recover the pipe and cables were impossible in the time available. The cause of failure is unknown, but may have resulted from differential freezing of the leads, as observed elsewhere. Displacing water in the drill pipe with antifreeze or the use of a stronger cable should overcome this.

The advantages of this technique of drilling lie in the speed of hole completion, the low weight and cost of the equipment, the simplicity of use and the ease of transportation. The major disadvantages are the need for a plentiful supply of water, which is pumped into the hole and surrounding media, and the lack of recovered cores. However, we believe that the water-jet drilling method has great promise as an inexpensive technique to acquire large amounts of shallow subsurface temperature information.

Acknowledgments

We wish to thank Dr. J. Ross Mackay for his support and the use of his water pump. We appreciate the long term loan of 21 m of water pipe made to us by the Polar Continental Shelf Project.

Project 740102

A. S. Judge¹, H. A. MacAulay², and J. A. Hunter²

During April 1976, five experimental holes were drilled into the seabottom of the Beaufort Sea Shelf near the Mackenzie Delta. Thermistor cables were installed in all holes and temperatures were read at periodic intervals during the weeks following installation. Accurate measurements of sub-seabottom temperatures indicated permafrost was present.

Location of Drillholes

Land-fast ice can be found extending as much as 20 miles offshore in the Mackenzie Delta area. In March and April the ice is often greater than 2 m thick and offers an excellent platform for a light-weight drilling operation.

The locations for the five holes were selected on the basis of existing sub-seabottom permafrost anomalies (see Fig. 17. 1). Two holes were drilled in Shallow Bay;

T-1 and T-2 were placed over locations of holes previously drilled by Northern Engineering where indications of ice-bonded permafrost had been found at shallow depths. Holes T-3, T-4 and T-5 were located on an east-west line approximately 32 km north of Hooper Island perpendicular to a seismic boundary delineated by Hunter *et al.* (1976). West of 134°W; the seismic results indicated the absence of ice-bonded permafrost.

Drilling Procedure

Hydraulic water-jet drilling techniques have been used extensively for water-well drilling in overburden in non-permafrost areas and to some extent in permafrost (Cederstrom and Tibbits, 1961). A simplified version of the technique was applied to thermistor cable installation in permafrost by Judge *et al.* (1975). From this experiment a more elaborate technique was designed

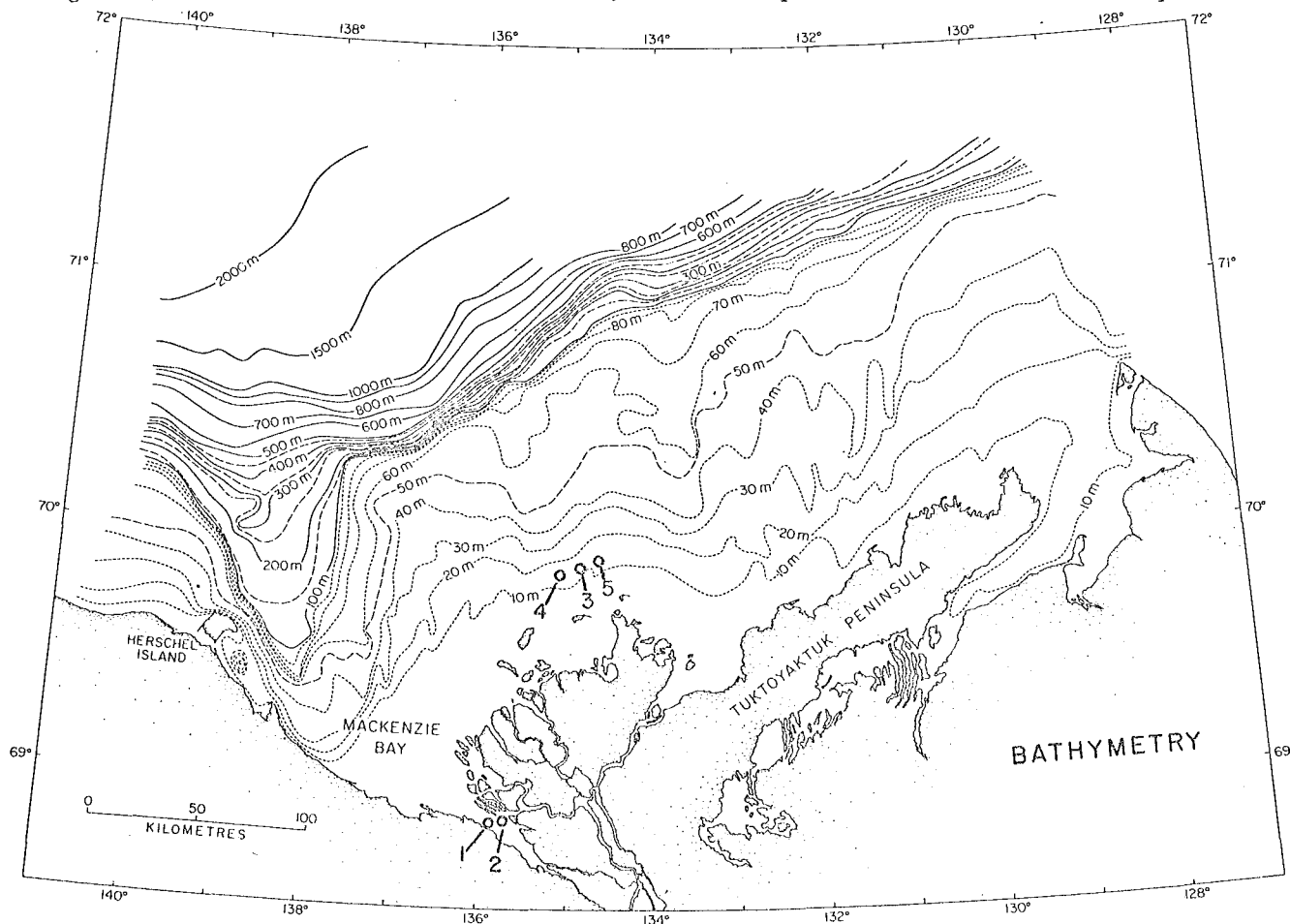

Figure 17. 1. Location of drillholes.

¹Earth Physics Branch

²Resource Geophysics and Geochemistry Division

to drill into seabottom materials from an ice platform. The procedure is shown in Figure 17.2. Jetting is done through a 2.5-cm steel water pipe (3-m sections). The first section contains a bit (cutting teeth fashioned from a 2.5-cm coupling) and 1 m of flighted section.

A water pump system delivering 235 psi (1.74 MPa) shutoff pressure was used. Pressure losses at the bit as a result of frictional losses in the pipe and the hydraulic head are estimated to be 1 psi per foot (.023 MPa/m) depth below sea-surface. Additional frictional losses in connector hoses, couplings and swivel-head could not be accurately estimated but probably result in the loss of a further 5-10 psi (.04 to .08 MPa).

Immediately after disconnecting at the swivel to add sections, washed samples were obtained from return flow up the pipe.

It was found that changes in drilling rates could be correlated with change in type of material washed as well as the degree of ice-bonding. In unfrozen recent muds drilling rates as high as 6 m/min were achieved; however, when drilling in ice-bonded sand, the rate dropped as low as 0.03 m/min.

Holes T-3, T-4, T-5 were drilled to refusal. In all cases temperature cables were installed by lowering through the drill pipe. After cable installation the drill pipe was disconnected at the coupling close to the sea floor, raised up several feet and was allowed to freeze into the surface ice; hence, ice movement could occur

without damage to the installation. Most installations were visited and temperatures were read at least three times during the survey period.

Results

Shallow Bay (Fig. 17.3a, 17.3b)

Two thermistor cables were installed in the Shallow Bay holes to depths of 30 and 50 m and the cables were periodically monitored for more than 500 hours after drill completion. A resulting ratio of settling to monitoring time of 58 on the last log should be sufficient to determine an equilibrium temperature if not to achieve equilibrium conditions.

Both temperature curves shown in Figure 17.3a and 17.3b exhibit the same characteristics of high positive temperatures (maximum of +2.6°C) 6 m below the sediment surface, negative temperature gradients (60 to 260 mK⁻¹) and negative bottom hole temperatures (minimum of -1.4°C). Although no sensors were placed above 5.5 m in T-2 the springtime near-surface sediment temperatures are probably close to 0°C which is similar to T-1.

Since the sensors used had a calibration accuracy of only $\pm 0.1^\circ\text{C}$ there is some uncertainty in the depth of the 0°C isotherm. In T-1 the isotherm lies at 15 ± 2 m below the sediment surface compared with a frozen ground depth determined from drilling of 14 ± 1 m, and in T-2 at 24 ± 2 m compared with 25 ± 1 m. The close correspondence between permafrost depth and the depth of ice-bonding suggests a lithology of fairly pure sand containing fresh water (0 to < 5000 ppm dissolved salts).

The observed temperature profiles can be explained in two fundamentally different ways. One involves essentially an equilibrium or near-equilibrium situation in which the two holes were drilled through topographic lows which locally retain water beneath the ice in winter but are surrounded by a sea bottom to which ice freezes in the winter. In this case permafrost at very shallow depths, and perhaps ice-bonded, would be widespread with talik zones developed in the topographic lows and on a surrounding shallow thaw zone corresponding to a sub-sea summer "active-layer". A second explanation involves non-equilibrium conditions in which the mean temperature at the sediment surface has increased from below freezing to above freezing temperatures and the permafrost is accordingly degrading from the top. This might be explained by a myriad of surface phenomena such as rising sea level, depression of the surface by sediment loading, shifting river channels, etc. The current depths to the top of permafrost suggest an increase which commenced 500 to 1000 years ago, present bottom-hole temperatures suggest that the previous sediment surface temperatures were at least -3°C, and that permafrost thickness may be in excess of 100 m.

To distinguish between these two explanations for the curves requires further geophysical work and drilling in Shallow Bay.

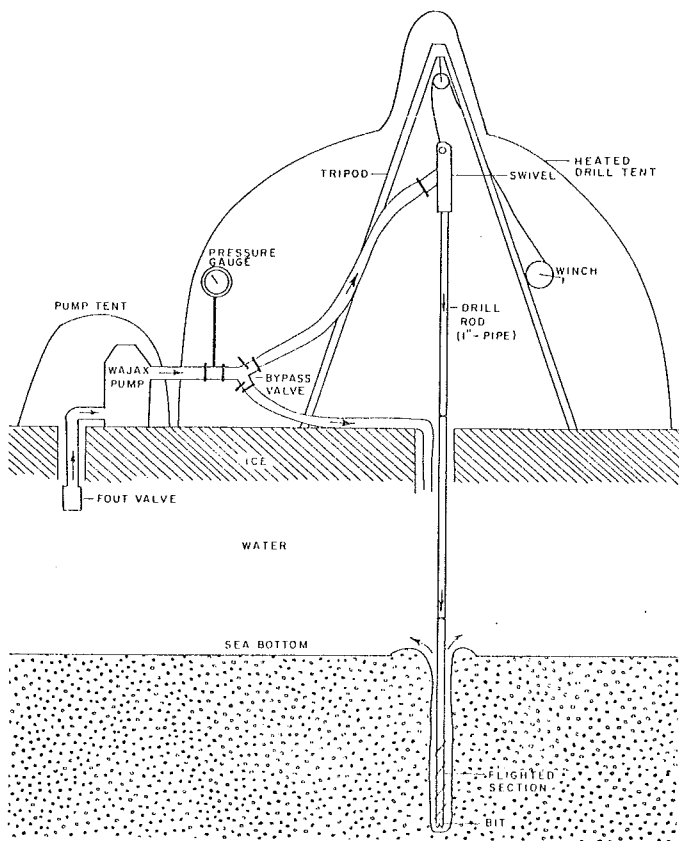

Figure 17.2. Diagrammatic representation of drilling technique.

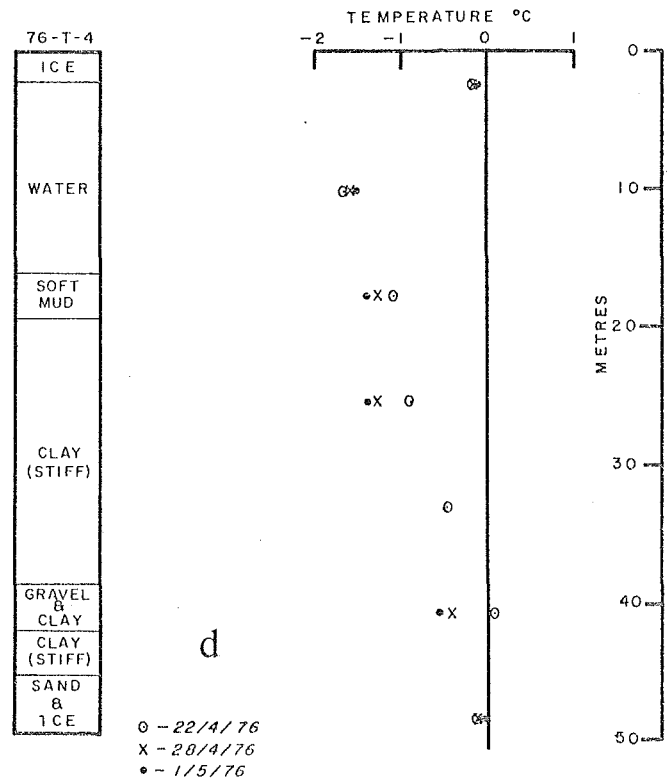
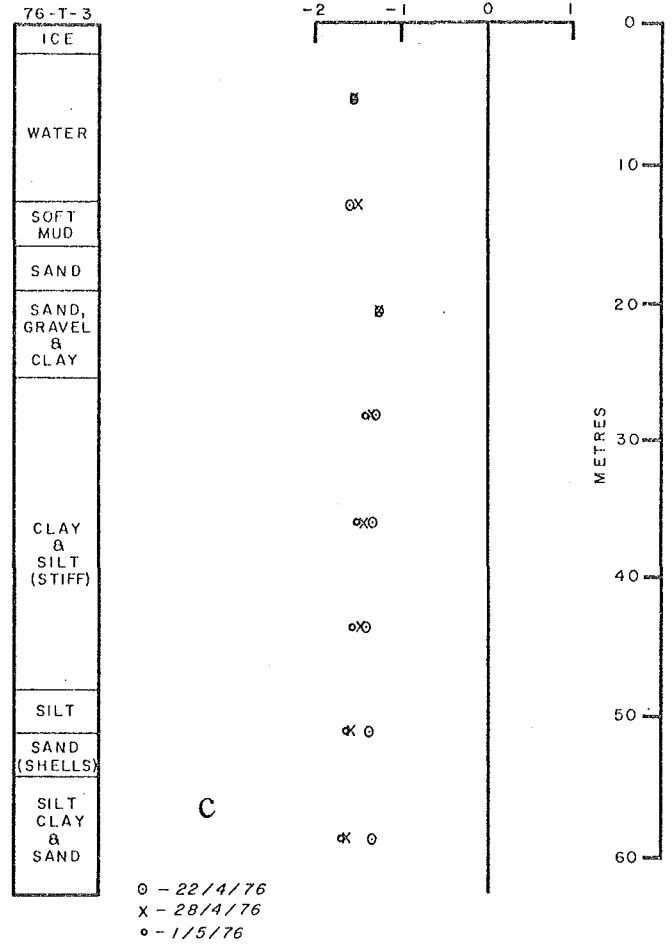
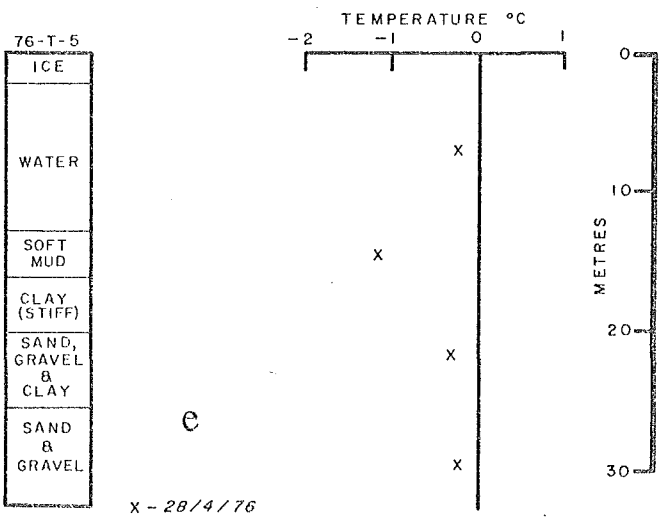
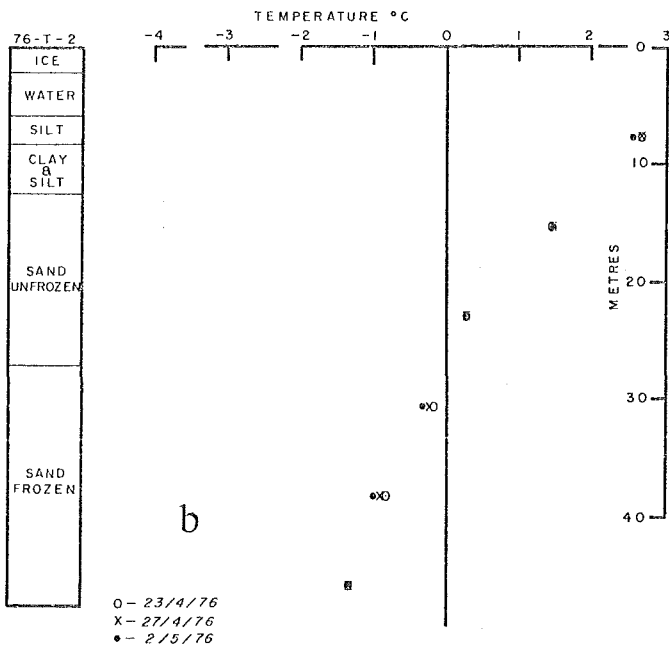
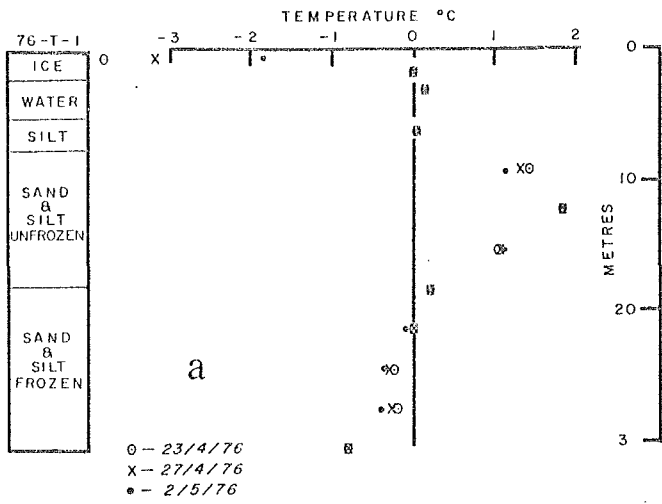

Figure 17. 3a-e. Temperature curves for various locations.

Three further thermistor cables were installed to depths of 30 to 59 m beneath water depths of 13 to 16 m on an east-west line approximately 32 km north of Hooper Island. The cables were monitored for periods of up to 340 hours after completion and since drilling time was somewhat less than in Shallow Bay reasonable ratios of settling to drilling time of 60 to 70 result for two of the holes. At hole T-5 the ice surface shifted between logs breaking the cable at the sea bottom, so that a single log at a time ratio of 77 is the only sub-bottom information obtained.

The appearance of the temperature logs at two of the sites differ dramatically from one another. Although in all three cases the temperatures at the sea bottom are similar at about -1.5°C , T-4 shown in Figure 17.3d exhibits a positive temperature gradient of 57 mK m^{-1} at a depth 10 m below the sediment surface and the temperature rises to 0°C at a depth of 35 m, whereas T-3, shown in Figure 17.3c exhibits a negative temperature gradient of 15 mK m^{-1} at a depth of 6 m below the sediment surface and the temperature falls to -1.9°C at a depth of 44 m. The limited data on T-5, shown in Figure 17.3e, is inconclusive; however negative temperatures were encountered 17 m beneath the sediment surface.

Unlike the Shallow Bay holes no particularly hard boundaries which could be attributed to a frozen to unfrozen interface were encountered during drilling, although ice was encountered in the sand near the base of T-4. Because this sand is at temperatures between -0.3°C and 0°C it must contain fresh water. The presence of ice-bonding or lensing in other horizons in holes T-3 to T-5 is unproven.

The temperature profiles exhibited by T-3 and T-4, sites separated by only 7.6 km, seem to reflect two very different situations. Whereas T-4, the westernmost site, seems to reflect a situation in which permafrost has grown to be observed depth and at present is in equilibrium with the earth's heat flux and the sea bottom temperature, T-3 reflects a non-equilibrium situation in which, similarly to Shallow Bay, the sediment surface temperature has increased from below -3°C to the present seabottom temperature, and permafrost thickness degraded from greater than 110 m. Two sets of results provide insufficient evidence on which to develop regional models; however, T-3 and T-4 are on the east and west sides of a major north-south seismic boundary described by Hunter *et al.* (1976). It is tempting to relate this boundary to the sea level and glacial history of the area. As suggested in Hunter *et al.* (1976) this complex history resulted largely in thin permafrost close to thermal equilibrium beneath sea bottom to the west of 135°W in contrast with the thick, relic, degrading permafrost found to the east. Since the thin permafrost

to the west is mainly in clays, ice-bonding is unlikely to be present and any ice-lensing present may not appear on conventional seismic records. Wherever sands are present at shallow depth intermittent reflections might appear. The thick but warm permafrost to the east incorporates both sands and clays; presumably each sand horizon is ice-bonded if it contains freshwater, will act as a seismic reflector whereas the clays containing ice-lenses only may not, this results in a very complex seismic pattern of refraction, reflection and diffraction below the first refracting horizon.

Obviously an explanation for the regional distribution of permafrost in the Beaufort Sea based on two sub-surface temperature profiles is open to question but the combination of seismic and thermal profiles provide strong supporting evidence. Further thermal profiling and additional geophysical profiling using electrical and more sophisticated seismic systems are required. Part of the thermal profiling should include instrumentation of both offshore island sites and Dome's drillship sites.

Conclusions

Combined thermal and seismic profiling of the offshore areas of northern Canada can provide valuable evidence for present permafrost distribution and character as well as provide some understanding of permafrost genesis and geological history. The jet-drilling technique is a simple and cheap method of drilling holes for thermal profiling to depths of at least 50 m beneath water depth of up to 20 m from a platform of winter ice.

Acknowledgments

The authors thank V. Allen for assistance in drilling, Polar Continental Shelf Project for providing logistics support and C. P. Lewis for donation of a 30 m thermistor cable.

References

- Cederstrom, D. J. and Tibbits, G. C.
1961: Jet Drilling in the Fairbanks Area, Alaska, U. S. Geol. Surv., Water Supply Paper 1539-B.
- Hunter, J. A. M., Judge, A. S., MacAulay, H. A., Good, R. L., Gagne, R. M., and Burns, R. A.
1976: The Occurrence of Permafrost and Frozen Sub-Seabottom Materials in the Southern Beaufort Sea; Beaufort Sea Project Tech. Rep. no. 22.
- Judge, A. S., Hunter, J. A., Good, R. L., Cowan, J., and Robb, G.
1975: Thermistor Cable Installation in Permafrost Materials with a Water-Jet Drilling Method; in Report of Activities, Part A, Geol. Surv. Can., Paper 76-1A, p. 479-480.