

WELL 5653
 N 7 054 513
 E 456 406
 DRILLERS REPORT
 NO.: n/a

Grassy Field

Fence

Airport Apron

MAYO AIRPORT
 TERMINAL
 BUILDING
 BLDG. #5653

Gravel Parking

UST Heating Oil
 Fill & Vent

Standby Diesel
 Generator

Fence

Septic Tank

Likely Location
 of Septic Field

NOT EXACTLY
 AS SHOWN

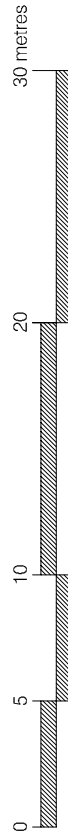

SCALE 1:300

NOTES:

1. UTM COORDINATES OBTAINED WITH A HAND HELD GPS USING NAD83 SYSTEM AND ARE CONSIDERED TO BE ACCURATE TO 10.0 m, APPROXIMATELY.

30 m RADIUS FROM WATER WELL FOR CONSIDERATION OF PROXIMITY TO POTENTIAL CONTAMINANT SOURCES.



EBA Engineering Consultants Ltd.

CLIENT:

DESIGNED BY: R. MARTIN
 DRAWN BY: J. BUICK
 DATE: SEPT. 2005
 SCALE: AS SHOWN
 PROJECT No.: 1260002.004
 ACAD FILENAME: 004-NORTHERN_REGION

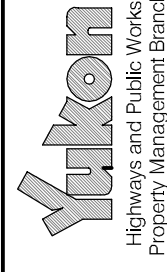

SMALL PUBLIC WATER SYSTEMS ASSESSMENT
 NORTHERN REGION

GOVERNMENT OF YUKON
 HIGHWAYS & PUBLIC WORKS



MAYO TERMINAL BUILDING
 BUILDING # 5653
 SITE LOCATION DIAGRAM

REVISION ISSUE
 0
 FIGURE No.
 WELL ID: 5653-A

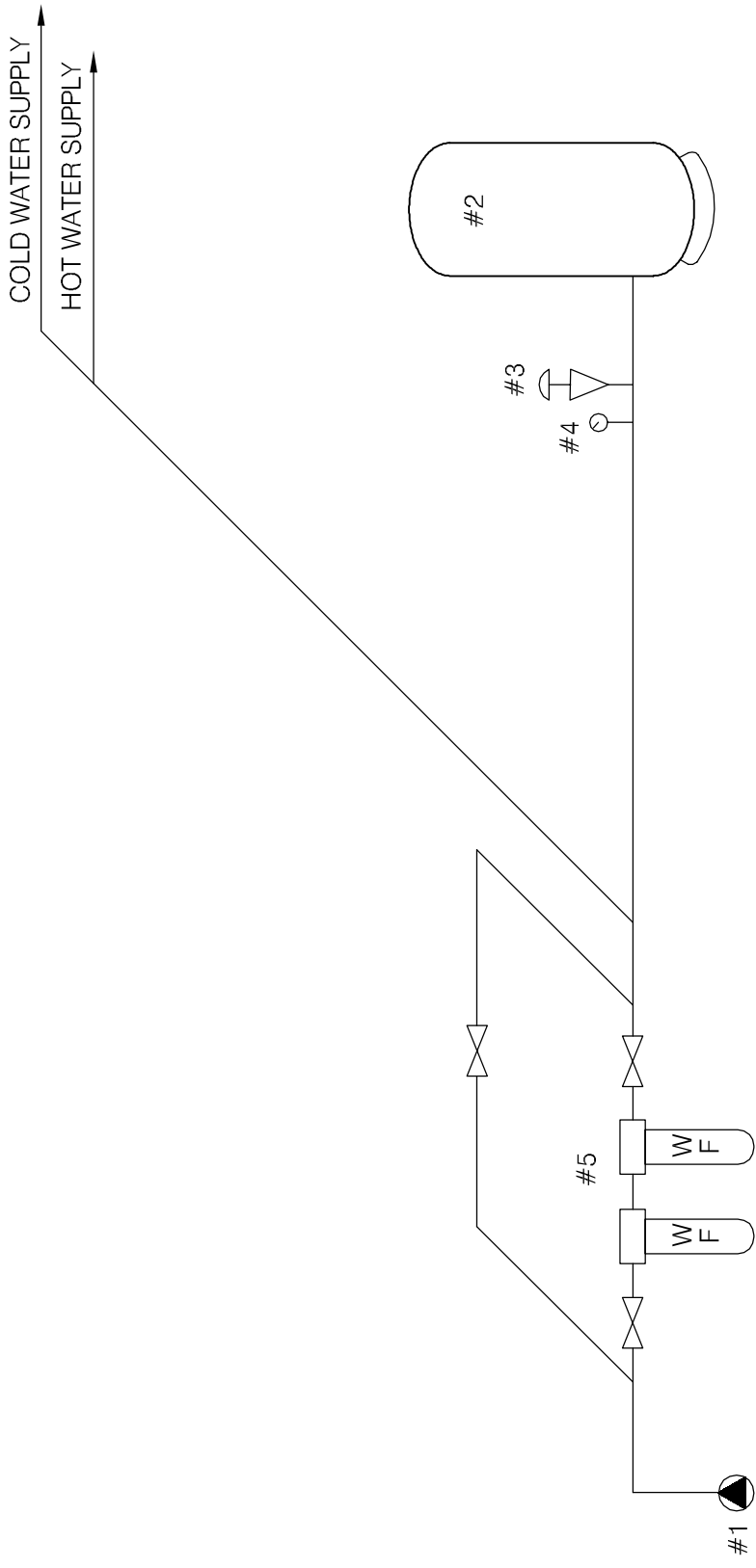
No.	ISSUED FOR CLIENT REVIEW	DATE	APPROVED	REVISION
0				



DRAWING IS BASED UPON SCHEMATIC PROVIDED BY BERT ALBISSER OF AQUA TECH SUPPLIES AND SERVICES LTD.

		PROJECT SMALL PUBLIC WATER SYSTEMS ASSESSMENT NORTHERN REGION	
CLIENT 		TITLE WATER SYSTEM DISTRIBUTION/TREATMENT SCHEMATIC SYSTEM ID.: 5653 AIR TERMINAL BUILDING - MAYO, YT.	
DATE	SEPT., 2005	FILE NO.	1260002.004
	DWN.	CHKD.	RMM
	JSB		DWG.: FIGURE 5653-B

Northern Region – Airport Terminal Building
Building # 5653

DISTRIBUTION & TREATMENT SYSTEM DATA

Item	Description	Manufacturer	Model	Part No.	Serial No.	Size
1	Sub Pump	MONARCH	SBS EX			3/4 HP - 4"
2	Pressure Tank	CHALLENGER	PC66			20 GALLON
3	Pressure Switch	SONARIED	FSG-2			2 HP - 1/4" FIP
4	Pressure Gauge	MARSH	0-100-2"			2" - 1/4 FIP
5	INLINE FILTER	ENVICO GUARD	5 MICRON	SEP 030 MICRON GAC		10" - 3/4"
6						
7						
8						
9						
10						

TABLE 5653- 1: SUMMARY OF BACTERIOLOGICAL RESULTS

Building #	Building Name	Number of Sampling Events	Time Period over which Sampling was Done	Any Positive Total Coliform Results? (yes or no)	Fraction of Positive Total Coliform Results vs. Total Sampling Events	Any positive E. Coli results? (yes or no)	Most Recent Sampling Event Available for EBA Review	Is Most Recent Result Positive?
5653	Mayo Airport Terminal Building	9	Oct-04 to Jun-05	yes	1/9	no	9-Jun-05	no



Table 5653 - 2: Water Quality Results

SOURCE:		Building 5653 - Mayo Airport Terminal Building		GCDWQ Criteria		
Location/ Resident		Mayo				
Address						
Treatment		Filtration				
Disinfection		None				
Source of Water		On-site well				
Purpose of Sampling		Base Line	Additional Sampling			
Sample Location			Washroom faucet			
Date Sampled		27-Sep-04	17-Aug-05	Lower	Upper Limit	
Physical Tests (ALS)				AO	MAC	AO
Colour (CU)		>60	<5.0			15
Conductivity (uS/cm)		388	652			
Total Dissolved Solids		388	436			500
Hardness CaCO3		349	333	AO >200 = poor, > 500 unacceptable ^A		
pH		8.14	8.15	6.5		8.5
Turbidity (NTU)		23.5	65.4		1	5
UV Absorbance			0.027			
% UV Transmittance			94			
Dissolved Anions (ALS)						
Alkalinity-Total CaCO3		313	296			
Chloride Cl		<0.5	<0.50			250
Fluoride F		0.11	0.121		1.5	
Silicate SiO4			11.4			
Sulphate SO4		72.8	85.8			500
Nitrate Nitrogen N		<0.01	<0.10		10	
Nitrite Nitrogen N		<0.005	<0.10		1	
Ammonia Nitrogen N						
Total Phosphate PO4			0.0794			
Total Metals (ALS)						
Aluminum T-Al		<0.005	<0.010		0.1	
Antimony T-Sb		<0.0002	<0.00050		0.006	
Arsenic T-As		0.0756	0.0575		0.025	
Barium T-Ba		0.037	0.033		1	
Boron T-B		0.011	<0.10		5	
Cadmium T-Cd		<0.00001	<0.00020		0.005	
Calcium T-Ca			83			
Chromium T-Cr		0.0019	<0.0020		0.05	
Copper T-Cu		<0.001	<0.0010		1	
Iron T-Fe		2.62	3.77			0.3
Lead T-Pb		<0.0001	<0.0010		0.01	
Magnesium T-Mg			30.7			
Manganese T-Mn		0.272	0.289			0.05
Mercury T-Hg			<0.00020		0.001	
Potassium T-K			2.04			
Selenium T-Se			<0.0010		0.01	
Sodium T-Na		8.7	9.6			200
Uranium T-U		<0.0005	0.00042		0.02	
Vanadium T-V			<0.030			
Zinc T-Zn		0.026	0.196			5
Dissolved Metals						
Arsenic D-As			0.0200		0.025	
Iron D-Fe			<0.030			0.3
Manganese D-Mn			0.273			0.05
Organic Parameters						
Tannin and Lignin			0.41			
Total Organic Carbon C			2.17			
Field Chemistry (EBA)						
pH			8.13	6.5		8.5
TDS (ppm)			324			500
EC (uS/cm)			649			
Temperature (°C)			5.6			
Free Available Chlorine						

Notes:

A. Guidelines indicated for hardness are not CDWQG, rather they are general aesthetic guidelines
 - exceedences are indicated in yellow highlighting.

Italic and underline indicates exceedence of proposed MAC (ie. arsenic)

Bold with Yellow highlighting indicates exceedence of CDWQG Aesthetic Objective (AO)

Bold Underline with Yellow highlighting indicates exceedence of CDWQG MAC

Results are expressed as milligrams per litre except for pH and Colour (CU)

Conductivity (umhos/cm), Temperature (°C) and Turbidity (NTU)

< = Less than the detection limit indicated.

AO = Aesthetic Objective

MAC = Maximum Acceptable Concentration (Health Based)



EBA Engineering Consultants Ltd.

Creating and Delivering Better Solutions

SMALL PUBLIC WATER SYSTEM ASSESSMENT

PART A: EBA Site Inspection

Inspector: Ryan Martin, Luke Lebel

Date August 17, 2005

WELL ID #	Owner	Location Description
5653	YTG	Mayo Airport Terminal Building

1. Well Location and Potential Contaminant Sources

a. General location of well: (Community, Subdivision, etc.)

Mayo

b. Specific location: (Road or street, Building number, name of owner and/, legal description,

Mayo Airport

c. GPS location: N 7054513 E 456406 elev 508m ± 12m

d. Is there electric power? Yes No

e. Is there outside water access? Yes No

f. Does the well system have:

15 or more service connections to a piped distribution system? If so how many _____

Mayo Airport Terminal Building

5 or more delivery sites on a trucked distribution system? If so how many _____

g. Nearest building, specify Terminal building

h. Distance from well to building ~ 3m

i. If there is an effluent disposal field, is its location known? Yes No

j. Distance from well to nearest point of known field: Tank @ ~ 34m, field > 34m (if present)

k. Well location relative to field: upslope downslope lateral

EBA Engineering Consultants Ltd.

Creating and Delivering Better Solutions

l. Is there any part of a sewage disposal system(s) or other potential sources of pollution that may pose a health and safety risk within 30 m? Yes No

Service lines only. Septic tank is pumped once per year. There may be a field, but unknown

m. Is the well located within 300 m from a sewage lagoon or pit? Yes No *unlikely*

n. Is the well located within 120 m from a solid waste site or dump, cemetery? Yes No
~63m from cemetery

o. Is the infrastructure protecting the wellhead, pumphouse, storage tank and/or water treatment plant designed and secured to prevent:

Unauthorized access by humans? Yes No *Unlocked enclosure* Entrance by animals? Yes No *Access possible*

p. Is well site subject to flooding? Yes No

q. Is the well site well drained? Yes No

r. Is there a buried fuel tank on the property? Yes No

If yes, is it in use abandoned

Is the location known? Yes No

Distance from the well to known buried tank *~18 m*

s. Are there any other known contaminant sources on the property?

Yes No Describe _____

If yes, specify the source: dump sewage lagoon cemetery other

Potential Source 1: *Bulk fuel storage*; Distance from well to Potential Source 1: *>60m*

Potential Source 2: _____; Distance from well to Potential Source 2: _____

Potential Source 3: _____; Distance from well to Potential Source 3: _____

Potential Source 4: _____; Distance from well to Potential Source 4: _____

t. Are there other wells on this property? Yes No *unlikely*

How many? _____ in use abandoned require proper sealing

EBA Engineering Consultants Ltd.

Creating and Delivering Better Solutions

2. Well and Wellhead information:

- a. When was well installed? Year unknown Month _____
- b. Type: drilled dug sand point other _____
- c. Is there a drillers log for the well: Yes No
- d. Is there a surface seal to 6 m Yes No unknown unlikely
- e. Surface casing: Yes Diameter _____ No
- f. Well casing: Diameter 15 cm Material: steel plastic concrete
- g. Depth of well: 38.100 m bc ^{could be pump} measured (if possible) reported from log
- h. Static water level below ground: 7.700 m bc
 measured (if possible) reported from log flowing
- i. (If granular) Is the well completed: open end casing with a well screen
 with slotted pipe unknown other _____
- j. (If bedrock) Does the well have a liner? yes No steel plastic
- k. If there is a well screen: length _____ slot size(s) _____
Location of screen: from _____ to _____ from log reported
- l. Is there a sump below the screen? Yes No unknown
- m. Is the well head: in pumphouse in pit pitless adaptor in a building
 in a wooden enclosure other, describe _____
- n. If the well head is located in a wooden enclosure,

EBA Engineering Consultants Ltd.

Creating and Delivering Better Solutions

- i. Is the well head below grade? describe in detail ~ 1.2m bg
- ii. Are there signs of ponding on the enclosure(e.g. water stains, etc.)? Yes No
- iii. Is the wellhead enclosed by fiberglass insulations? Yes No has been removed
- iv. Any evidence of rodents? Specify Access possible
- v. Does the well casing have a proper seal cap? Yes No

If no, describe condition No cap - only garbage bag above well casing

3. Water Supplying This Well:

- a. By definition is the water from a surface water source or under the direct influence of surface water?
 Yes No farther investigation required.

If yes is there treatment or disinfection Yes No

Explain (filtration, disinfection etc...) _____

4. Aquifer Supplying This Well:

- a. The aquifer is: bedrock granular sediment unknown

- b. Does water level and/or well capacity show seasonal fluctuation? Yes No
unlikely

5. Pump Installation:

- a. Is the well equipped with a pump? yes No

- b. Type of pump: hand electric submersible jet

shallow well centrifugal other, _____

- c. Description: Manufacturer _____ Model _____
horsepower _____ capacity _____ voltage _____

EBA Engineering Consultants Ltd.

Creating and Delivering Better Solutions

d. Date installed: _____ By: _____

e. For submersible pump, depth of setting below surface _____

f. Drop pipe for submersible pump: steel plastic

g. Pump delivers water to: pressure tank elevated tank other

h. Are there automatic pump controls: Yes No

i. Is there provision for taking water samples before water reaches storage? Yes No
But directly against floor

j. Is there a water meter on the system? Yes No

k. Is the pump and piping protected from freezing? Yes No

If yes, describe: Has been disconnected/removed

l. Comments on pump installation: _____

6. Conclusions

a. Comments on overall installation:

b. Recommendations: _____

EBA Engineering Consultants Ltd.

Creating and Delivering Better Solutions

PART B: EBA Site Inspection

Inspector: BERT ALBISSER

Date AUG 17 / 05

WELL ID #	Owner	Location Description
5653	YTG	MAYO AIR PORT

6. Water Treatment

a. Is well water treated? Yes No; Type of treatment:

chlorination iron and or manganese removal other _____

b. Is water entering plumbing or piped distribution system treated with chlorine or another treatment that is as effective as chlorine used to achieve disinfection throughout the system?

Yes No If so how _____

c. If treated with chlorine, is the free residual chlorine concentration less than 0.2 mg/L

Yes No _____ reading.

Tested at _____ (location)

d. Is testing for chlorine residual concentration done at the tap (eg. Kitchen faucet) or from representative points in a piped distribution system, including a point from tap at the end line

Yes No If yes how often? _____

e. If the drinking water is being transported by water delivery truck does it have a minimum chlorine free residual of 0.4 mg/L at the time of fill. Yes No

7. Water Quality (observations):

a. Does the water stain plumbing? yes No slight severe

Type of stain: brown red black

b. Does the water contain sediment? Yes No occasional constant

c. Is there an unpleasant odour? Yes No H₂S Other _____

EBA Engineering Consultants Ltd.

Creating and Delivering Better Solutions

- d. Is there an unpleasant taste? Yes No brackish Other _____
- e. Is there a history of bad bacterial analyses? Yes No ?
- f. Is there a chemical analysis? Yes No adequate incomplete
- g. Is there analysis of trihalomethanes (THMs) where the water source is a surface water supply or a well under the direct influence of surface water? Yes No
- h. Is the drinking water tested daily with an accurate reading chlorine test kit capable of reading in the range 0 to 3.5 mg/L of free chlorine residual in increments of 0.1mg/L? Yes No unknown
- i. If yes is the test performed in accordance with manufactures directions? Yes No unknown
- j. Is a record of the date, time, name of person performing the test and results of the drinking water sample kept? Yes No

TANK AND PIPING DETAILS

Tank Room

Is there a water tank? Yes No Details: PRESSURE TANK

Where is it located?

Comments: FURNACE ROOM

Is the room in which the water tank is located heated to maintain an optimum temperature of 4°C for stored water?

YES NO

Comments: _____

Are there windows in the add-on that may allow direct sunlight onto the water holding tank? YES

NO

Comments: _____

Are there other heat sources near the tank? YES NO

Comments: _____

Is there waterproof flooring with a sealed base to contain spills? YES NO

Comments: _____

EBA Engineering Consultants Ltd.

Creating and Delivering Better Solutions

Overall Tank

What are the tank size and dimensions?

What material is the tank constructed of? _____

Is tank and associated piping constructed of safe materials (i.e. CSA approved and material that does not affect the taste of the water)? YES NO

Comments: _____

Tank Inlet, Outlet and Lid

Is there adequate access on the tank for cleaning (i.e. min 15" access lid)? YES NO

Does the lid have a tight seal and is it watertight when closed? YES NO

Does the tank have an overflow or high level whistle? YES NO

Is the water tank drain accessible? YES NO

WATER TANK AND WATER QUALITY CONDITION

Are there signs of staining or biofouling? YES NO

Comments: _____

Is there any sediment or scum in bottom of tank? YES NO

Comments: _____

Is there any odour associated with the water or tank? YES NO

Have there been any bacteriological analyses conducted previously? YES NO

Does the tank appear that it has been cleaned recently? YES NO

Are the tanks easily assessed for the purpose of cleaning and disinfection? YES NO

8. Conclusions

a. Comments on overall installation:

THE WATER SYSTEM IS OLD AND JUDGING BY
SCUM AND RUST-BUILDUP IN JANITORIAL SINK IN
FURNACE ROOM, HEAVILY SCALED UP WITH CALCIUM
& RUST DEPOSIT.

b. Recommendations:

INSTALL COMMERCIAL TREATMENT SYSTEM AS
DICTATED BY THE CHEMICAL ANALYSIS
PAST KNOWLEDGE I WOULD RECOMMEND
DUPLEX SOFTNER SYSTEM, SMALL COMMERCIAL
RO SYSTEM WITH LARGE PRESSURE TANK.



Spill Report Information

Spill #	7613
Jurisdiction	Yukon
Community	Mayo
Address	
Highway	
Milepost	
Feature	Mayo
Location and Cause	WPYR tank farm - failure of loading hose
Latitude	63.6133333333333
Longitude	-135.879166666667
Incident Date	8/26/1976 10:00:00 PM
Lead Agency	Department of Indian Affairs and Northern Development
Other Agency	
Company(s)	White Pass & Yukon Route
Amount	1512
Units	Litres
Quantity	Actual
Release Description	Spilled
Additional Quantit	
Concentration	
Concentration Unit	
Phase	Liquid
Major Contaminant	Furnace Oil
2nd Contaminant	
3rd Contaminant	
4th Contaminant	
Outcome	spill dyked off immediately - contaminated area 15' x 150' - cleaned-up (contaminants removed to Mayo dump)



Spill Report Information

Spill #	7718
Jurisdiction	Yukon
Community	Mayo
Address	
Highway	
Milepost	
Feature	Mayo
Location and Cause	tank farm - tank overfilled
Latitude	63.6133333333333
Longitude	-135.879166666667
Incident Date	8/22/1977 9:00:00 AM
Lead Agency	Environment Canada - Environmental Protection Service
Other Agency	Department of Indian Affairs and Northern Development
Company(s)	White Pass & Yukon Route
Amount	3742
Units	Litres
Quantity	Actual
Release Description	Spilled
Additional Quantitit	
Concentration	
Concentration Unit	
Phase	Liquid
Major Contaminant	Fuel Oil
2nd Contaminant	
3rd Contaminant	
4th Contaminant	
Outcome	no fuel recovered - possible contamination of groundwaters but not known - suggests action be taken as too many spills with no recovery in area



Environment
Canada

Environnement
Canada

Enforcement and Emergencies Section

91782 Alaska Highway, Whitehorse, YT Y1A 5B7

PH: 867.667.3400 FAX: 867.667.7962

Spill Report Information

Spill #	7727
Jurisdiction	Yukon
Community	Mayo
Address	
Highway	
Milepost	
Feature	Mayo
Location and Cause	tank farm - tank overfilled
Latitude	63.6133333333333
Longitude	-135.879166666667
Incident Date	3/28/1977 9:00:00 AM
Lead Agency	Environment Canada - Environmental Protection Service
Other Agency	
Company(s)	White Pass & Yukon Route
Amount	1512
Units	Litres
Quantity	Actual
Release Description	Spilled
Additional Quantitit	
Concentration	
Concentration Unit	
Phase	Liquid
Major Contaminant	Gasoline
2nd Contaminant	
3rd Contaminant	
4th Contaminant	
Outcome	spill within dyke - none reported outside dyke - cleaned-up



Spill Report Information

Spill #	9130
Jurisdiction	Yukon
Community	Mayo
Address	
Highway	
Milepost	
Feature	Mayo
Location and Cause	White Pass yard - garage caught on fire - explosion ensued
Latitude	63.616666666667
Longitude	-135.884444444444
Incident Date	11/26/1991
Lead Agency	Yukon Government - Fire Marshall
Other Agency	
Company(s)	White Pass
Amount	
Units	
Quantity	Unknown
Release Description	Burned
Additional Quantit	
Concentration	
Concentration Unit	
Phase	Liquid
Major Contaminant	Hydrocarbons
2nd Contaminant	
3rd Contaminant	
4th Contaminant	
Outcome	fuel or propane truck exploded inside building - building consumed - used 756,000L water - water runoff contained in ditch - oil and fuel in water



Spill Report Information

Spill #	9703
Jurisdiction	Yukon
Community	Mayo
Address	
Highway	
Milepost	
Feature	Mayo
Location and Cause	North 60 Petroleum Bulk Plant - overfill of bulk storage tank - miscommunication between truck operator and plant operator
Latitude	63.6134
Longitude	-135.8793
Incident Date	1/15/1997 6:40:00 PM
Lead Agency	Yukon Government - Public Safety
Other Agency	Environment Canada - Environmental Protection Service
Company(s)	North 60 Petroleum
Amount	1000
Units	Litres
Quantity	Estimate
Release Description	Spilled
Additional Quantitit	
Concentration	
Concentration Unit	
Phase	Liquid
Major Contaminant	Diesel
2nd Contaminant	
3rd Contaminant	
4th Contaminant	
Outcome	300 L recovered - EC recommended excavation of contaminated soil and installation of monitoring wells - fuel discrepancy of 22,000 L reported by Mayo plant - not verified



Spill Report Information

Spill #	9947
Jurisdiction	Yukon
Community	Mayo
Address	
Highway	
Milepost	
Feature	Mayo
Location and Cause	North 60 Petroleum Tank Farm - overfill of storage tank
Latitude	63.6134
Longitude	-135.8793
Incident Date	12/10/1999 5:10:00 PM
Lead Agency	Environment Canada - Environmental Protection Service
Other Agency	
Company(s)	North 60 Petroleum
Amount	
Units	
Quantity	Unknown
Release Description	Spilled
Additional Quantitit	negligible amount
Concentration	
Concentration Unit	
Phase	Liquid
Major Contaminant	Diesel
2nd Contaminant	
3rd Contaminant	
4th Contaminant	
Outcome	overfill caused product to run down sides of tank and small amount to ground at base of tank within berm - no loss noted in records check - minimal amount spilled - no action

 <p>Photo 0187: 5653 Mayo Airport wellhead enclosure.</p>	 <p>Photo 0189: 5653 Pressure tank and pump controls.</p>
 <p>Photo 027: 5653 Mayo Airport Terminal Building.</p>	 <p>Photo 007: 5653 Septic tank (front) and bulk fuel storage (back).</p>