

LEGEND



PUMP



PRESSURE GAUGE



GATE VALVE



CHECK VALVE



SOLENOID

#2

COMPONENT ID. No.
(SEE TABLE ON FOLLOWING PAGE)



FLOW METER



WATER FILTER
(CARTRIDGE TYPE)

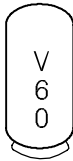

PRESSURE TANK



CL₂

CHLORINE RESERVOIR AND
INJECTION PUMP

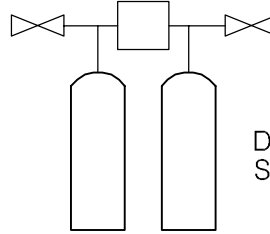

DUPLEX WATER
SOFTENER



SP

WELL WITH
SUBMERSIBLE PUMP

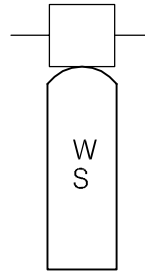

ACTIVATED
CARBON

Z:\0201\Drawings\1260002 Water Assessment YTG\001 - Whitehorse Region\1260002003 Whitehorse Schematic_LEGEND.dwg, 4/11/2006 10:28:07 AM, Adobe PDF, jbuyck



EBA Engineering Consultants Ltd.

PROJECT SMALL PUBLIC WATER SYSTEMS ASSESSMENT
WHITEHORSE REGION

CLIENT



TITLE

**SCHEMATIC SYSTEM
LEGEND**

DATE APRIL 2006

DWN. JSB



CHKD. RMM

FILE NO. 1260002

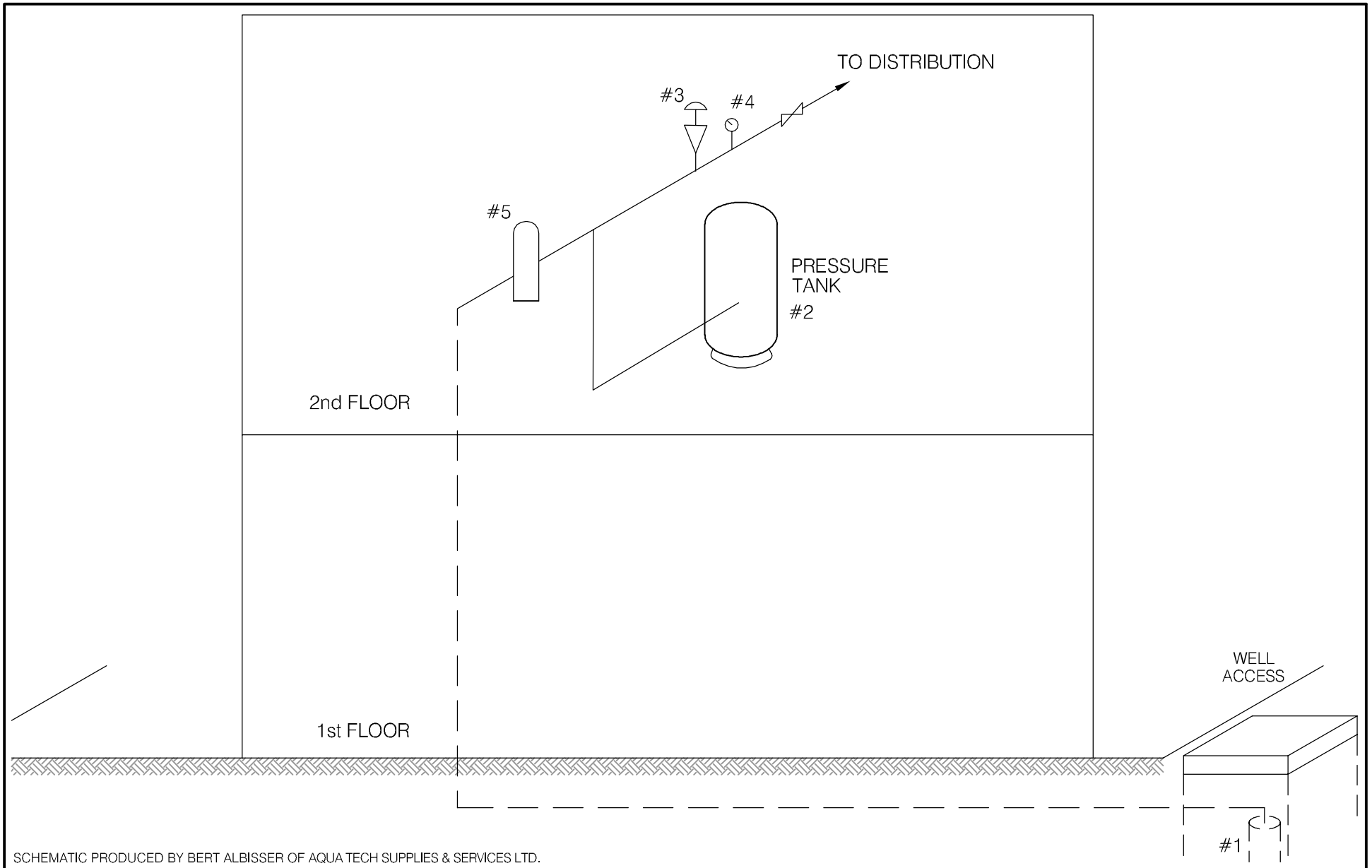
DRWG. LEGEND



SCHEMATIC PRODUCED BY BERT ALBISSER OF AQUA TECH SUPPLIES & SERVICES LTD.

 EBA Engineering Consultants Ltd.	PROJECT SMALL PUBLIC WATER SYSTEMS ASSESSMENT WHITEHORSE REGION			
CLIENT 	TITLE WATER SYSTEM DISTRIBUTION/TREATMENT SCHEMATIC SYSTEM ID.: M0093 CARMACKS RCMP DETACHMENT WELL			
DATE APRIL 2006	DWN. JSB	CHKD. RMM	FILE NO. 1260002.001	DWG.: FIGURE M0093B

Whitehorse Region – R.C.M.P. Detachment
Building # MO093

DISTRIBUTION & TREATMENT SYSTEM DATA

Item	Description	Manufacturer	Model	Part No.	Serial No.	Size
1	4" SUBMERSIBLE	MYERS	3NFL72-12		0593	4" - 3/4 HP.
2	PRESSURE TANK	WELL RITE	WR26002			
3	PRESS SWITCH	SQ. D.	FSG-2			
4	PRESS GAUGE	MARSH	0-100			1/4" FIPT.
5	IN LINE STRAINER	SARCO				1" FIPT
6						
7						
8						
9						
10						

TABLE M0093 - 1: SUMMARY OF BACTERIOLOGICAL RESULTS

		Number of Sampling Events	Time Period over which Sampling was Done	Any Positive Total Coliform Results? (yes or no)	Fraction of Positive Total Coliform Results vs. Total Sampling Events	Any positive E.Coli results? (yes or no)	Most Recent Sampling Event Available for EBA Review	Is Most Recent Result Positive?
Building #	Building Name							
M0093	R.C.M.P. Detachment	7	Sept-04 to Mar-05	no	0/7	no	2-Mar-05	no



Table M0093-2: Water Quality Results

		Building M0093 - SOURCE: R.C.M.P. Detachment		GCDWQ Criteria		
Location/ Resident		Carmacks				
Address		Lot B-12				
Treatment		No				
Source of Water		On-Site Well				
Purpose of Sampling		Baseline	Additional Sampling			
Sample Location		Kitchen Sink				
Date Sampled		5-Oct-04	12-May-05	Lower Limit	Upper Limit	
Physical Tests (ALS)				AO	MAC	AO
Colour (CU)		5				15
Conductivity (uS/cm)		328				
Total Dissolved Solids		216				500
Hardness CaCO3		201		AO >200 = poor, > 500 unacceptable ^A		
pH		7.9		6.5		8.5
Turbidity (NTU)		0.25			1	5
UV Absorbance			<0.0010			
Dissolved Anions (ALS)						
Alkalinity-Total CaCO3		188				
Chloride Cl		3				250
Fluoride F		0.21			1.5	
Sulphate SO4		18.9				500
Nitrate Nitrogen N		0.1			10	
Nitrite Nitrogen N		<0.05			1	
Ammonia Nitrogen N						
Total Metals (ALS)						
Aluminum T-Al		<0.02				
Antimony T-Sb		0.0007			0.006	
Arsenic T-As		0.0004			0.025	
Barium T-Ba		0.0583			1	
Boron T-B		<0.02			5	
Cadmium T-Cd		<0.0002			0.005	
Calcium T-Ca		57.9				
Chromium T-Cr		0.0016			0.05	
Copper T-Cu		0.045			1	
Iron T-Fe		0.052				0.3
Lead T-Pb		0.0036			0.01	
Magnesium T-Mg		12.1				
Manganese T-Mn		<0.001				0.05
Mercury T-Hg		<0.0002			0.001	
Potassium T-K		2.2				
Selenium T-Se		<0.0004			0.01	
Sodium T-Na		7				200
Uranium T-U		0.0011			0.02	
Zinc T-Zn		0.008				5
Field Chemistry (EBA)						
pH			7.77	6.5		8.5
TDS			181			500
EC (uS/cm)			356			
Temperature			7.8			
Free Available Chlorine						250

Notes:

A. Guidelines indicated for hardness are not CDWQG, rather they are general aesthetic guidelines - exceedences are indicated in yellow highlighting.

Shading indicates exceedence of Proposed MAC guideline (arsenic).

Bold Underline with Yellow shading indicates exceedence of CDWQG MAC

Results are expressed as milligrams per litre except for pH and Colour (CU), Conductivity (umhos/cm), Temperature (°C) and Turbidity (NTU)

< = Less than the detection limit indicated.

AO = Aesthetic Objective

MAC = Maximum Acceptable Concentration (Health Based)



**Table M0093-3: Summary of Well Assessment Results
SMALL PUBLIC DRINKING WATER SYSTEMS**

Well Identification and Location					
Building #	Building Name	Location	Northing (+/- 10 m)	Easting (+/- 10 m)	Grade Elevation (+/- 10 m)
MOO93	R.C.M.P. Detachment	Carmacks	6884845	432680	528

Well Details							
Well Casing Diameter (mm)	Year Well Installed	Well Log?	Well Depth (m bg)	Reported Low Permeabilty Protective Layer?	Pump Setting (m bg)	Well Capacity - Tested, or Reported by User	Static Water Level Below Ground (m-btwc)
150	?	No	16.080	No, shallow well	?	3/4hp submersible pump Size of pump meets needs	?

Well Construction Details				
Wellhead Above ground (m)	Well Cap	Well Screen	Surface Seal	Apron Grading
1.14 below grade	Split Cap Gasket	?	Unlikely	No, ground is even



**Table M0093-4: Potential Contaminant Sources
Building: M0093 - RCMP Detachment**

Potential Contaminant Source	Potential Contaminants	Distance from Water Source	Northing	Easting
Dump or Landfill	<i>Organic</i> and inorganic chemicals.	1300 m		
Cemetery	<i>Biological</i> ¹ , inorganic ² and organic parameters.	350 m		
Sewage lagoon	<i>Biological</i> , inorganic and organic parameters.	>300 m		
Sewage lines, tanks and lift stations	<i>Biological</i> , inorganic and organic parameters.	<20 m to service lines and <30 to main		
Septic fields	<i>Biological and Inorganic</i> parameters.	>150 m		
Gas stations	<i>Organic and Inorganic</i> parameters.	250 m		
Undergrounds Fuel Storage Tanks (USTs)	<i>Organic</i> parameters.	>30 m		
Above ground storage tanks (ASTs)	<i>Organic parameters.</i>	(2) 9 m and (2) 40 m	6884850 6884810	432688 432685
Naturally occurring sources of contamination	<i>Radionuclides, Bacteria and Viruses from surfacewater sources.</i>	75 m		

Notes: *Bold highlighting of distances indicates non-compliance with proposed guidelines*

1- Biological parameters include: bacteria, viruses, protozoa (parasitic organisms), helminthes (intestinal worms), and bio aerosols (inhalable moulds and fungi).

2 – Inorganic contaminants could include arsenic in embalming chemicals (prior to early 1900’s), and heavy metals in caskets.

Required Setback Distances Draft Guidelines for Part III – Small Public Drinking Water Systems:

300 m (1,000 ft) from a sewage lagoon or pit and manure heaps

120 m (400 ft) from a solid waste dump or a cemetery

30 m (100 ft) from any other potential source of contamination

SMALL PUBLIC WATER SYSTEM ASSESSMENT

PART A: EBA Site Inspection

Inspector: Ryan Martin
Luke Lebel

Date May 12, 2005

WELL ID #	Owner	Location Description
M0093	RCMP	Carmacks RCMP Detachment

1. Well Location and Potential Contaminant Sources

a. General location of well: (Community, Subdivision, etc.)

Carmacks

b. Specific location: (Road or street, Building number, name of owner and/, legal description,

Carmack RCMP detachment

c. GPS location: 432680 Easting 6884845 Northing 528m elevation ±11m

d. Is there electric power? Yes No

e. Does the well system have:

15 or more service connections to a piped distribution system? If so how many _____
Carmacks RCMP Detachment only

5 or more delivery sites on a trucked distribution system? If so how many _____

f. Nearest building, specify Carmacks RCMP Detachment

g. Distance from well to building 2m

h. If there is an effluent disposal field, is its location known? Yes No

i. Distance from well to nearest point of known field: _____

j. Well location relative to field: upslope downslope lateral

EBA Engineering Consultants Ltd.

Creating and Delivering Better Solutions

k. Is there any part of a sewage disposal system(s) or other potential sources of pollution that may pose a health and safety risk within 30 m? Yes No

Sewage line within 30m

l. Is the well located within 300 m from a sewage lagoon or pit? Yes No

m. Is the well located within 120 m from a solid waste site or dump, cemetery? Yes No
~1km away from solid waste dump

n. Is the infrastructure protecting the wellhead, pumphouse, storage tank and/or water treatment plant designed and secured to prevent:

Unauthorized access by humans? Yes No *only a manhole cover, no lock. Can be accessed with a pick or crowbar* Entrance by animals? Yes No *Not completely (some traces of animals) but in concrete encasing w/ manhole cover*

o. Is well site subject to flooding? Yes No *it's underground and there is evidence of water entering the well pit*

p. Is the well site well drained? Yes No

q. Is there a buried fuel tank on the property? Yes No *unlikely*

If yes, is it in use abandoned

Is the location known? Yes No

Distance from the well to known buried tank _____

r. Are there any other known contaminant sources on the property?

Yes No Describe _____

If yes, specify the source: dump sewage lagoon cemetery other

Potential Source 1: AST 1 + AST 2; Distance from well to Potential Source 1: ~9m

Potential Source 2: AST 3 + AST 4; Distance from well to Potential Source 2: ~40m

Potential Source 3: _____; Distance from well to Potential Source 3: _____

Potential Source 4: _____; Distance from well to Potential Source 4: _____

s. Are there other wells on this property? Yes No

How many? MOO 94 in use abandoned require proper sealing

EBA Engineering Consultants Ltd.

Creating and Delivering Better Solutions

2. Well and Wellhead information:

- *a. When was well installed? Year _____ Month _____
- b. Type: drilled dug sand point other _____
- *c. Is there a drillers log for the well: Yes No
- d. Is there a surface seal to 6 m Yes No unknown unlikely
- e. Surface casing: Yes Diameter 61 cm No
Steel manhole cover
- f. Well casing: Diameter 15 cm Material: steel plastic concrete
- g. Depth of well: 14.940m measured (if possible) reported from log
bc
- *h. Static water level below ground: _____
 measured (if possible) reported from log flowing
- *i. (If granular) Is the well completed: open end casing with a well screen
 with slotted pipe unknown other _____
- *j. (If bedrock) Does the well have a liner? yes No steel plastic
- *k. If there is a well screen: length _____ slot size(s) _____
Location of screen: from _____ to _____ from log reported
- l. Is there a sump below the screen? Yes No unlikely
- m. Is the well head: in pumphouse in pit pitless adaptor in a building
concrete walls w/ steel manhole cover
 in a wooden enclosure other, describe _____
- n. If the well head is located in a wooden enclosure,

EBA Engineering Consultants Ltd.

Creating and Delivering Better Solutions

- i. Is the well head below grade? describe in detail 114cm below grade
- ii. Are there signs of ponding on the enclosure(e.g. water stains, etc.)? Yes No
There is some moisture and evidence of water seeping into the enclosure
- iii. Is the wellhead enclosed by fiberglass insulations? Yes No
The enclosure is filled with loose fiberglass insulation pieces
- iv. Any evidence of rodents? Specify very little
- v. Does the well casing have a proper seal cap? Yes No

If no, describe condition _____

3. Water Supplying This Well:

- a. By definition is the water from a surface water source or under the direct influence of surface water?
 Yes No farther investigation required.

If yes is there treatment Yes No

Explain (filtration, disinfection etc...) _____

4. Aquifer Supplying This Well:

- a. The aquifer is: bedrock granular sediment unknown
- b. Does water level and/or well capacity show seasonal fluctuation? Yes No
unknown

5. Pump Installation:

- a. Is the well equipped with a pump? yes No
- b. Type of pump: hand electric submersible jet
 shallow well centrifugal other, _____
- c. Description: Manufacturer _____ Model _____
horsepower _____ capacity _____ voltage _____

EBA Engineering Consultants Ltd.

Creating and Delivering Better Solutions

- d. Date installed: _____ By: _____
- e. For submersible pump, depth of setting below surface _____
- f. Drop pipe for submersible pump: steel plastic
- g. Pump delivers water to: pressure tank elevated tank other
- h. Are there automatic pump controls: Yes No
- i. Is there provision for taking water samples before water reaches storage? Yes No
- j. Is there a water meter on the system? Yes No
- k. Is the pump and piping protected from freezing? Yes No
There is heat trace and fibreglass insulation within the well enclosure
If yes, describe: _____
- l. Comments on pump installation: _____

6. Conclusions

a. Comments on overall installation:

b. Recommendations:



Location: RCMP Detachment Well Lot B-12 CRMK

NAD 83 Zone 8 Easting 432679.74 Northing 6884827.8 Elevation ASL 1 m.

Location Accuracy: Horizontal 30-100 (topo) Purpose of well: Commercial - not fabrication or manufacturing
 Vertical unknown or unreliable

Permafrost encountered? No

LOG OF OVERBURDEN AND BEDROCK MATERIALS

Layer	From	To	General Colour	Most Common Material	Secondary Material	General Description
1	0	4.88 m.		SAND and gravel		
2	4.88	5.49 m.		SILT, clay, sand		
3	5.49	8.84 m.		GRAVEL, sand		
4	8.84	14.94 m.		SILT		

WELL CONSTRUCTION

Well No. 1090100321 Completion date [] Drilling method [] Well type []

Casing: OS Diameter [] mm. Material [] Wall thickness [] mm. Depth to [] m.

Comments []

Surface/Env'l seal: Material [] Diameter [] mm. Depth from [] to [] m. Volume [] cu. m.

Gravel Pack ? Material [] Diameter [] mm. Depth from [] to []

Well Screen Information

OS Diameter	Material	Screen Type	Comments
[]	[]	[]	[]

Screen Sections

Section	From	to	Slot size/ perforation diameter
1	[]	[]	[]

WELL DEVELOPMENT AND STATUS

Well ID 1090100321 Developed by [] Wellhead completion [] Adapter depth [] m. Static water level [] m. Yield Estimate [] Lps Estimate method []

Final Status New, in use for intended purpose

No

GROUNDWATER QUALITY

Well No. 1090100321 Field Measurement Date 10-Dec-02

Electrical Conductivity 385 μ S
 pH 7.35
 Temperature 5.5 $^{\circ}$ C

Groundwater Type []
 Turbidity/sand content []

Well disinfection
 Was the well disinfected on completion of pump installation?

Bacterial testing done? Lab [] Date []
 Chemical testing done? Lab [] Date []

EBA Engineering Consultants Ltd.

Creating and Delivering Better Solutions

PART B: EBA Site Inspection

Inspector: _____

Date _____

WELL ID #	Owner	Location Description
M0093	YTG	CERMAICS DETACHMENT

6. Water Treatment

a. Is well water treated? Yes No; Type of treatment:

chlorination iron and or manganese removal other _____

b. Is water entering plumbing or piped distribution system treated with chlorine or another treatment that is as effective as chlorine used to achieve disinfection throughout the system?

Yes No If so how _____

c. If treated with chlorine, is the free residual chlorine concentration less than 0.2 mg/L

Yes No _____ reading.

Tested at _____ (location)

d. Is testing for chlorine residual concentration done at the tap (eg. Kitchen faucet) or from representative points in a piped distribution system, including a point from tap at the end line

Yes No If yes how often? _____

e. If the drinking water is being transported by water delivery truck does it have a minimum chlorine free residual of 0.4 mg/L at the time of fill. Yes No

7. Water Quality (observations):

a. Does the water stain plumbing? yes No slight severe

Type of stain: brown red black

b. Does the water contain sediment? Yes No occasional constant

c. Is there an unpleasant odour? Yes No H₂S Other _____

EBA Engineering Consultants Ltd.

Creating and Delivering Better Solutions

- d. Is there an unpleasant taste? Yes No brackish Other _____
- e. Is there a history of bad bacterial analyses? Yes No *N/A.*
- f. Is there a chemical analysis? Yes No adequate incomplete *N/A.*
- g. Is there analysis of trihalomethanes (THMs) where the water source is a surface water supply or a well under the direct influence of surface water? Yes No
- h. Is the drinking water tested daily with an accurate reading chlorine test kit capable of reading in the range 0 to 3.5 mg/L of free chlorine residual in increments of 0.1mg/L? Yes No unknown
- i. If yes is the test performed in accordance with manufactures directions? Yes No unknown
- j. Is a record of the date, time, name of person performing the test and results of the drinking water sample kept? Yes No

TANK AND PIPING DETAILS

Tank Room

Is there a water tank? Yes No Details: *PRESSURE TANK.*

Where is it located?

Comments: *BASEMENT.*

Is the room in which the water tank is located heated to maintain an optimum temperature of 4°C for stored water?

YES NO

Comments: _____

Are there windows in the add-on that may allow direct sunlight onto the water holding tank? YES

NO

Comments: _____

Are there other heat sources near the tank? YES NO

Comments: _____

Is there waterproof flooring with a sealed base to contain spills? YES NO

Comments: _____

8. Conclusions

a. Comments on overall installation:

PROFESSIONAL INSTALLATION. NO DEFICIENCIES.

b. Recommendations:

INSTALL IRON SOFTENER & UV SYSTEM
CONSISTING OF PROPER PREFILTER
& UV SYSTEM.

EBA Engineering Consultants Ltd.

Creating and Delivering Better Solutions

Overall Tank

What are the tank size and dimensions?

What material is the tank constructed of? _____

Is tank and associated piping constructed of safe materials (i.e. CSA approved and material that does not affect the taste of the water)? YES NO

Comments: _____

Tank Inlet, Outlet and Lid

Is there adequate access on the tank for cleaning (i.e. min 15" access lid)? YES NO

Does the lid have a tight seal and is it watertight when closed? YES NO

Does the tank have an overflow or high level whistle? YES NO

Is the water tank drain accessible? YES NO

WATER TANK AND WATER QUALITY CONDITION

Are there signs of staining or biofouling? YES NO

Comments: _____

Is there any sediment or scum in bottom of tank? YES NO

Comments: _____

Is there any odour associated with the water or tank? YES NO

Have there been any bacteriological analyses conducted previously? YES NO

Does the tank appear that it has been cleaned recently? YES NO

Are the tanks easily assessed for the purpose of cleaning and disinfection? YES NO



Photo 0144: M0093 Wellhead in Pit



Photo 0146: M0093 Two Above Ground Storage Tanks



Photo 0008: M0093 Pressure Tank



Photo 0010: M0093 Pump Control Panel