



Bellekeno Preliminary Economic Assessment Technical Report

Keno Hill Mining District, Yukon

Prepared for:

Alexco Resource Corp.
Suite 1150, 200 Granville Street
Vancouver, BC V6C 1S4

Prepared by:



Project No. 2CA017.000

June 2008

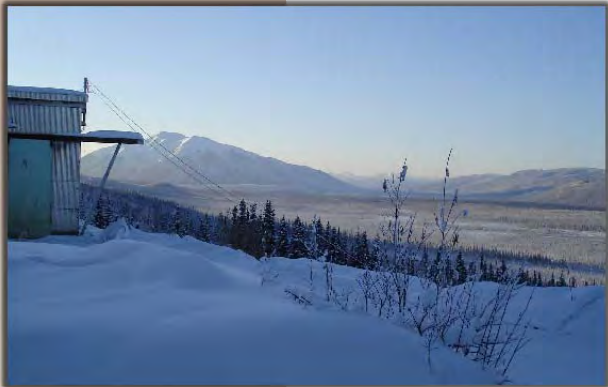

Bellekeno Technical Report

Keno Hill Mining District, Yukon

Alexco Resource Corp.

SRK Consulting (Canada) Inc.
Suite 2200, 1066 West Hastings Street
Vancouver, BC V6E 3X2

Tel: 604.681.4196 Fax: 604.687.5532
E-mail: vancouver@srk.com Web site: www.srk.com

SRK Project Number 2CA017.000

June 30, 2008

The Qualified Persons for this report are:

Dave Keller, P.Geo. SRK
Joe Sedlacek, P. Eng. SRK
Gordon Doerksen, P. Eng. SRK
Hassan Ghaffari, P. Eng. Wardrop
Diane Lister, P.Eng. Altura

Table of Contents

1	Executive Summary	1
2	Introduction	8
3	Reliance on Other Experts	10
4	Property Description and Location	11
5	Accessibility, Climate, Local Resources, Infrastructure and Physiography	12
6	History	13
7	Geological Setting	14
8	Deposit Types	15
9	Mineralization	16
10	Exploration	17
11	Drilling	18
	11.1 Historical Drilling	18
	11.2 2006/2007 Alexco Drilling	19
12	Sample Method and Approach	21
	12.1 Historical Exploration and Sampling	21
	12.2 Alexco 2006 and 2007 Exploration and Sampling Programs	22
13	Sample Preparation, Analyses and Security	24
	13.1 Historical Samples	24
	13.2 Alexco 2006 – 2007 Exploration Programs	24
	13.3 Quality Assurance and Quality Control Programs.....	25
	13.3.1 Historical Exploration.....	25
	13.3.2 Alexco 2006 and 2007 Exploration Programs.....	25
14	Data Verification	27
	14.1 Verifications by Alexco	27
	14.1.1 Site Visit.....	27
	14.1.2 Verification of Historical Data	28
	14.1.3 Verification of Alexco Data	28
15	Adjacent Properties	30
16	Mineral Processing and Metallurgical Testing	31
	16.1 Testwork Review.....	31
	16.1.1 Background	31

16.1.2 Testwork Programs	31
16.1.3 Test Samples	32
16.1.6 Filtration and Thickening Test	39
16.2 Design Criteria	39
16.3 Flowsheet Development.....	41
16.4 Process Description	41
16.4.1 Crushing and Screening.....	41
16.4.2 Grinding Circuit.....	43
16.4.3 Silver-Lead Flotation	43
16.4.4 Zinc Flotation.....	44
16.4.5 Pyrite Flotation	44
16.4.6 Concentrate Dewatering.....	45
16.4.7 Tailings and Pyrite Concentrate Dewatering and Handling	45
16.4.8 Reagent Handling and Storage.....	46
16.4.9 Instrumentation and Process Control.....	46
16.4.10 General Plant Location	46
16.5 Process Options.....	48
16.5.1 Potential Mill Locations.....	48
16.5.2 Portable vs. Stationary Mill.....	49
16.5.3 Concentrate Shipment Options	49
16.5.4 Tailings Handling (Hydraulic Tails or Dry Stack).....	49
16.5.5 Mill Infrastructure.....	50
17 Mineral Resource and Mineral Reserve Estimates.....	51
17.1 Introduction	51
17.2 Bellekeno Historical Resource Estimate	51
17.2.1 Historical Polygon Estimate Procedures	51
17.2.2 Alexco Audit of Historical Resources	52
17.2.3 SRK Audit of Historical Resources.....	53
17.3 Bellekeno Southwest and East Zone Resource Estimates	54
17.3.1 Specific Gravity Measurements.....	54
17.3.2 Data	55
17.3.3 Geological Interpretation	56
17.3.4 Drill Hole Database	58
17.3.5 Specific Gravity Data.....	59
17.3.6 Statistical Analysis and Compositing	61
17.3.7 Grade Capping	68
17.3.8 Variography	72
17.3.9 Block Model.....	73
17.3.10 Estimation	75
17.3.11 Estimation Validation	77
17.3.12 Sensitivity Analysis	78
17.3.13 Mineral Resource Classification	81
17.3.14 Bellekeno Southwest and East Mineral Resource Statement.....	82
17.4 Consolidated Mineral Resource Statement for the Bellekeno Deposit.....	83
17.4.1 Bellekeno Resource Model	84
17.5 Life of Mine Plan Resource Estimate	85
17.5.1 Recovery and Dilution	85
17.5.2 LOM Plan Tonnes	85
18 Other Relevant Data and Information.....	86
18.1 General Site Infrastructure	86
18.1.1 Water Supply and Distribution.....	86
18.1.2 Assay Laboratory	87
18.1.3 Temporary Construction Facilities.....	87
18.1.4 Electrical Power.....	87

18.1.5 Housing	90
18.1.6 Medical Facilities and First Aid.....	90
18.1.7 Communications.....	91
18.1.8 Access Roads	91
18.1.9 Transportation and Shipping	91
19 Additional Requirements for Technical Reports on Development Properties and Production Properties	93
19.1 Proposed Mining Operations.....	93
19.1.1 Mining Context	93
19.1.2 Mining Method Selection	102
19.1.3 Mine Access	105
19.1.4 Stopping	109
19.1.5 Drilling.....	112
19.1.6 Blasting.....	112
19.1.7 Mucking	113
19.1.8 Grade Control.....	113
19.1.9 Backfill	113
19.1.10 Development and Development Schedule	115
19.1.11 Production Rate and Schedule.....	116
19.1.12 Equipment Requirement and Schedule.....	117
19.1.13 Material Handling.....	120
19.1.14 Ventilation	122
19.1.15 Mine Infrastructure.....	125
19.2 Recoverability.....	127
19.3 Markets	127
19.4 Contracts.....	128
19.5 Environmental Considerations	128
19.5.1 Environmental Setting	128
19.5.2 Environmental Studies	130
19.5.3 Regulatory Regime.....	131
19.5.4 Project Permitting	131
19.5.5 Closure	132
19.6 Taxes 133	
19.7 Capital and Operating Cost Estimates	134
19.7.1 Operating Cost Estimate	134
19.7.2 Capital Cost Estimate.....	136
19.8 Economic Analysis	140
19.8.1 Introduction.....	140
19.8.2 NPV and IRR Summary	141
19.8.3 Sensitivity Analysis.....	143
19.9 Payback	144
19.10 Mine Life	144
20 Interpretations and Conclusions	145
20.1.1 Conclusions.....	145
20.1.2 Risks and Opportunities	145
21 Recommendations.....	147
22 Acronyms and Abbreviations	149
23 References.....	150

24 Date and Signature Page.....	151
25 Illustrations.....	152
APPENDIX A.....	153
Cash Flow Models (Wardrop).....	153
APPENDIX B.....	154
Geostatistical Data	154

List of Tables

Table 1.1: Summary of Metallurgical Recoveries.....	2
Table 1.2: Consolidated Mineral Resource Statement* for the Bellekeno Deposit, (SRK Consulting, January 2008, 2008).....	3
Table 1.3: LOM Tonnes by Mining Method	3
Table 1.4: LOM Production Schedule	4
Table 1.5: Bellekeno Project Unit Operating Cost Summary (\$/t milled).....	4
Table 1.6: PEA Capital Cost Summary (\$'000)	5
Table 1.7: Economic Evaluation at Various Metal Prices.....	6
Table 2.1: List of Qualified Persons	8
Table 3.1: Non-Qualified Person Contributors	10
Table 13.1: Commercial Standard Reference Material Used by Alexco for the 2006 and 2007 Drilling Programs.	26
Table 14.1: Quality Control Data Produced by Alexco in 2006 and 2007.....	29
Table 16.1: Historical Operation Data	31
Table 16.2: Head Assays – 1996 Test Samples	33
Table 16.3: Head Assay – 2007 Test Sample	33
Table 16.4: Regrind Test Results – 1996 Test Program	36
Table 16.5: Locked Cycle Test Results - Lakefield	38
Table 16.6: Locked Cycle Test Results (PRA)	39
Table 16.7: Settling Test Results	39
Table 16.8: Process Design Criteria.....	40
Table 17.1: Bellekeno Historical Resource Calculation Audit - Alexco Calculations Compared to UKHM Calculations.....	53
Table 17.2: Mineral Resource Statement* for the Bellekeno 99 Zone, SRK Consulting, November 10, 2007.....	54
Table 17.3: Summary of Database Used For Modelling the Bellekeno Southwest Zone.....	55
Table 17.4: Summary of Database Used for Modelling the Bellekeno East Zone	55
Table 17.5: Statistics for Core Specific Gravity Measurements Southwest and East Zones	59
Table 17.6: Summary Statistics for Southwest Zone Chip and Core Samples.	62
Table 17.7: Summary Statistics for Southwest Zone Core Samples.....	62
Table 17.8: Summary Statistics for East Zone Chip and Core Samples	63
Table 17.9: Summary Statistics for East Zone Core Samples	63
Table 17.10: Summary Statistics for the Southwest Zone Drill Core Composites	67
Table 17.11: Summary statistics for the East Zone Drill Core Composites.....	68
Table 17.12: Datamine Variogram Orientation.....	72
Table 17.13: Variogram Ranges	73
Table 17.14: Characteristic of the Bellekeno Block Models.	73
Table 17.15: Tonnage and Grade Sensitivity Results for Southwest Zone, Percentage of Resource Model*	79
Table 17.16: Tonnage and Grade Sensitivity Results for Southwest Zone*	80
Table 17.17: Tonnage and Grade Sensitivity Results for East Zone, Percentage of Resource Model*	80
Table 17.18: Tonnage and Grade Sensitivity Results for East Zone*	81
Table 17.19: Mineral Resource Statement* for the Bellekeno Southwest and East Zones (SRK Consulting, January 28, 2008).....	83
Table 17.20: Tonnage and Grade at Various Cut-off Grades Southwest Zone	83
Table 17.21 Tonnage and Grade at Various Cut-off Grades East Zone	83

Table 17.22: Consolidated Mineral Resource Statement* for the Bellekeno Deposit, (SRK Consulting, January 28, 2008).....	84
Table 17.23: Bellekeno Life of Mine Plan Diluted Tonnes and Grade.....	85
Table 19.1: Mining Method Selection.....	102
Table 19.2: Development Schedule.....	115
Table 19.3: Production Schedule by Mining Method.....	117
Table 19.4: Production Schedule by Zones and Grade.....	117
Table 19.5: Equipment Requirements (No. of units).....	118
Table 19.6: Labour Requirements.....	119
Table 19.7: Management and Technical Staff.....	119
Table 19.8: Waste Rock Tonnage Estimates and AML Classification.....	121
Table 19.9: Average Temperatures for Mayo, YT (°C).....	124
Table 19.10: Assumed PEA Metallurgical Performance.....	127
Table 19.11: Mine Unit Operating Cost (\$/t milled).....	134
Table 19.12: Summary of Unit Mine Operating Costs by Activity (\$/t milled).....	134
Table 19.13: Process Operating Cost Summary – Initial Two Years.....	135
Table 19.14: Process Operating Cost Summary – Full Operation.....	136
Table 19.15: Total Unit Operating Cost (\$/t milled).....	136
Table 19.16: Mining Capital Cost Estimate (\$'000).....	137
Table 19.17: Capital Cost Equipment (\$'000).....	138
Table 19.18: Process Capital Cost Summary.....	139
Table 19.19: Bellekeno Project Capital Estimate (\$'000).....	140
Table 19.20: Economic Evaluation at Various Metal Prices.....	141
Table 19.21: Base Case Cash Flow Analysis.....	142

List of Figures

Figure 16.1: Lead and Zinc Recovery at Lead Rougher Flotation vs. Mass Pull.....	34
Figure 16.2: Effect of Collectors on Lead, Zinc, and Silver Recovery at Lead Rougher Flotation ..	35
Figure 16.3: Locked Cycle Test Flowsheet - Lakefield.....	38
Figure 16.4: Simplified Bellekeno Process Flow Sheet.....	42
Figure 16.5: General Overview Map.....	47
Figure 17.1: Southwest Zone Geological Boundaries Looking Northwest. Schist Unit Lower Contact (blue), Greenstone Unit Upper Contact (green), Bellekeno Southwest Zone Model (red)56	
Figure 17.2: East Zone Geological Boundaries Looking Northwest. Northeast Bounding Fault (brown), Bellekeno East Model (red) and High Grade Shoot (light blue).....	57
Figure 17.3: Linear Regression between Lead Grades and Pulp Specific Gravity Southwest Zone60	
Figure 17.4: Q-Q Plots Comparing Chip and Core Samples for the Southwest Zone. Top Left: Silver Grade, Top Right: Lead Grade, Bottom: Zinc Grade.....	65
Figure 17.5: Top. Q-Q plots Comparing Chip and Core Samples East Zone. Top Left: Silver Grade, Top Right: Lead Grade, Bottom: Zinc Grade.....	66
Figure 17.6: Cumulative Probability Plots for Southwest Zone Drill Core Composite Samples.....	70
Figure 17.7: Cumulative Probability Plots for East Zone Drill Core Composite Samples.....	71
Figure 17.8: Variograms Modelled by SRK for the Silver Composites. Top: Parallel to Strike. Bottom: Parallel to the Dip Direction.....	74
Figure 17.9: Linear Regression Relationship between Core and Pulp Specific Gravity Determinations.....	76
Figure 17.10: Relationship between Estimated Block Specific Gravity (DENSITY) and Block Lead Grade in Percent (PPBPCT).....	77

Figure 17.11: Longitudinal View of Bellekeno Deposit showing AgEq Block Model Values	85
Figure 18.1: Bellekeno Electrical Single-line Diagram	88
Figure 19.1 Bellekeno Schematic: Historic and Proposed Development, and Geological Contacts	95
Figure 19.2: Joint Measurements from Historical UG Mapping at Bellekeno Mine	97
Figure 19.3: Bedding Measurements from Historical UG Mapping at Bellekeno	97
Figure 19.4: Geotechnical Assessment of Southwest Zone: Domains and Width	99
Figure 19.5: Geotechnical Assessment of the East Zone: Domains and Width	100
Figure 19.6: K-07-0083 Mineralized Zone (yellow) and Immediate Hangingwall (red) with Poor Ground Conditions.....	101
Figure 19.7: K-07-0092 Mineralized Zone (yellow) and Immediate Hangingwall (red) with Good Ground Conditions.....	101
Figure 19.8: Overhand, Mechanized Cut & Fill Mining Method (from Atlas Copco).....	103
Figure 19.9: Long Hole Mining Method (source: Atlas Copco).....	104
Figure 19.10: Shrinkage Mining Method (source: Atlas Copco).....	105
Figure 19.11: Proposed Bellekeno East Decline.....	106
Figure 19.12: Wedge Failure Diagram in the Middle Quartzite Unit.....	107
Figure 19.13: Bellekeno 625 Level Charging Station	107
Figure 19.14: Span and Support Evaluations Based on the Q-System: SW Zone	110
Figure 19.15: Span and Support Evaluations Based on the Q-System: East Zone	111
Figure 19.16: Schematic Ventilation flow	124
Figure 19.17: NPV Sensitivity Analysis	143
Figure 19.18: IRR Sensitivity Analysis	144

APPENDICES

- Appendix A Cash Flow Models (Wardrop)**
- Appendix B Geostatistical Data**
- Appendix C Underground Geotechnical Information**

1 Executive Summary

Introduction

This preliminary economic assessment technical report (“PEA”) was prepared for Alexco Resource Corp. (“Alexco”) by SRK Consulting (Canada) Inc. (“SRK”) to provide an initial overview of the economic potential of extracting and processing mineralized material from the Bellekeno polymetallic deposits.

Wardrop Engineering Inc. (“Wardrop”) completed the metallurgical, mineral processing and economic analysis sections of this report with input contributions from SRK and Alexco. Numerous Alexco personnel, particularly Tim Hall, Manager Project Development, provided significant information and technical input into the report. Diane Lister of Altura Environmental Consulting produced the environmental section of the report.

Location and Land Holdings

The Bellekeno deposit is located in the historic Keno Hill Mining District that envelopes the villages of Elsa and Keno City (63° 55’N, 135° 29’W), in central Yukon Territory. The region has been mined intermittently for over 90 years. The closest town is Mayo, approximately 55 kilometres to the south of the project via an all-weather road. Whitehorse is approximately 460 km south of Mayo.

The land controlled by Alexco, following the issuance of a Care and Maintenance Water License in late November 2007, comprises 713 surveyed quartz mining leases, 794 unsurveyed quartz mining claims and two crown grants. The total area is approximately 23,350 hectares. Mineral exploration at Keno Hill is permitted under the terms and conditions set out by the Yukon Government in a Class IV Quartz Mining Land Use Permit – LQ-00240, issued in June 2008, and governs all exploration activities on the property including advanced exploration for the Bellekeno deposit. The permit supersedes the earlier mining land use permits for the property. The mineral resources and the underground infrastructure of the Bellekeno Project reported herein are all located within six contiguous Quartz claims inside the large Keno Hill property.

The climate of the Bellekeno area is characterized by a sub-arctic continental climate with cold winters and warm summers. Average temperatures in the winter are between -15° and -20° C while summer temperatures average around 15° C. Exploration and mining can be conducted year-round. The landscape around the Bellekeno project is characterized by rolling hills and mountains up to 1,200 metres in elevation. Vegetation is abundant.

Exploration

On June 19, 2008, Alexco announced it was granted a Class IV Quartz Mining Land Use Permit – LQ0024, allowing the development of an exploration decline in the central portion of the Bellekeno deposit. Procon Mining and Tunnelling Ltd. (“Procon”) was awarded a contract to drive approximately 650 m of decline and ancillary development that will access old workings and establish diamond drilling locations for a 10,000 m exploration and definition diamond drilling program. The Bellekeno exploration program also includes the mining of a bulk sample for metallurgical testing and the rehabilitation of the old 625 portal workings. A “Type B” water license is being pursued by Alexco to allow for mine dewatering.

Metallurgy and Mineral Processing

Test results indicate that the mineralization of the Bellekeno deposit responds well to a lead and zinc differential flotation process using a cyanide-free zinc mineral suppression regime. Silver minerals are intimately associated with lead minerals and will be recovered as a silver-lead concentrate. A separate zinc concentrate will also be produced from the Bellekeno operation.

The design capacity of the process plant will be 408 tonnes per day (“t/d”). Overall plant availability is estimated to be 92%. Run-of-mine (ROM) material from different mineralized zones is planned to be processed by conventional crushing, grinding, and flotation followed by concentrate dewatering. The estimated power requirement for the surface plant and facilities is approximately 1.3 MW. As a part of the scope of work, Wardrop assessed the opportunity to reuse the existing mill facilities near the town of Elsa. The study also shows a preliminary assessment of potential process plant locations and a comparison of concentrate haulage routes.

Metallurgical performance estimated from test work and assumed for this report is based on test work completed by SGS Lakefield in 2007 and by Process Research Associates (“PRA”) in 1996. Table 1.1 shows the assumed metallurgical recoveries used in this report.

Table 1.1: Summary of Metallurgical Recoveries

Mineralization Zone	Product	Grade				Recovery			
		Ag (g/t)	Pb (%)	Zn (%)	Au (g/t)	Ag (%)	Pb (%)	Zn (%)	Au (%)
99 and Southwest Zones	Pb/Ag Conc	4,782	72.0	1.5	0.6	87.1	96.5	6.9	50.0
	Zn Conc	1,159	2.6	52.0	0.5	8.0	1.3	90.2	17.0
	Tailing	87	0.5	0.2	0.1	4.9	2.2	2.9	33.0
	Feed	1,221	16.6	4.9	0.3	100.0	100.0	100.0	100.0
East Zone	Pb/Ag Conc	7,021	60.0	6.0	10.5	72.2	80.0	0.8	41.5
	Zn Conc	60	0.4	55.0	0.3	8.5	7.4	96.0	18.1
	Tailing	69	0.3	1.0	0.4	19.3	12.6	3.2	40.4
	Feed	232	1.8	19.0	0.6	100.0	100.0	100.0	100.0

Resources

The resources used in the mine plan and subsequent economic analysis in this report are all in the inferred mineral resource category. The 99 and Southwest zones are similar in high silver and lead content. The East zone varies from 99 and Southwest with significantly lower silver and lead grades but much higher zinc grades. Table 1.2 summarizes the Bellekeno mineral resource statement.

Table 1.2: Consolidated Mineral Resource Statement* for the Bellekeno Deposit, (SRK Consulting, January 2008, 2008)

Category	Zone	Tonnage [t]	Ag [g/t]	Pb [%]	Zn [%]	Au [g/t]	AgEq [g/t]
Inferred	99 [†]	55,700	1,593	11.1	5.5	0.0	2,375
	Southwest ^{†**}	302,100	1,357	20.4	5.5	0.4	2,494
	East ^{†**}	179,600	263	2.0	21.3	0.6	1,698
Total Inferred		537,400	1,016	13.5	10.7	0.4	2,216

* Mineral resources are not mineral reserves and do not have demonstrated economic viability. All figures have been rounded to reflect the relative accuracy of the estimates.

† Reported at a cut-off of 15 troy ounces per ton silver. Silver grades capped at 100 troy ounces per ton.

‡ Reported at a cut-off of 1000 grams per tonne silver equivalent. Grades not capped.

** Metal price and recovery factor assumptions for resource are: US\$8.00 Silver troy ounce, US\$1.00/kg (US\$0.45 per pound) Lead, US\$1.65/kg (US\$0.75 per pound) Zinc, metallurgical recovery factors have been assumed to be 100%. Gold was not used in silver equivalent calculation.

Mining

The Bellekeno project is comprised of a series of at least 11 veins in the Southwest, 99 and East zones. Most of the historical mining at Bellekeno occurred in the 99 zone. The veins have variable dip, strike and thickness. Dips range from 60° to 80° to the east or west. The average strike direction is approximately 030 azimuth. Vein thickness varies from a few centimetres to several metres.

Based on the preliminary geotechnical and physical characteristics of the veins, a mining method review was conducted and cut and fill, shrinkage stoping and long hole mining methods were considered the most appropriate at Bellekeno. Cut and fill and shrinkage stoping methods typically offer a high degree of selectivity that generally translates into high mineralization extraction and low waste dilution. Long hole mining is planned only for pillar extraction in certain areas. The percent of total life of mine (“LOM”) tonnes by mining method are shown in Table 1.3.

Table 1.3: LOM Tonnes by Mining Method

Mining Method	Percent of Total Tonnes
Cut & Fill	78 %
Shrinkage	20 %
Long Hole (pillar recovery)	2 %
Total	100 %

The LOM planned tonnes and grades were estimated using a 14% dilution factor and a 100% extraction of the resource above the cut-off grade. These factors were applied universally for all mining methods and mining areas as there is not enough information currently available to do a

detailed extraction and dilution analysis. The factors used, increase the resource tonnage in the mine plan by 14% and decrease the resource grade by 12%.

Mine production is planned to be 250 t/d in the first two years of operation with mill feed coming from the SW and 99 zones. Planned production increases to 400 t/d when 150 t/d is added in years 3, 4 and 5 when mining in the East zone is scheduled. Table 1.4 shows the LOM production schedule.

Table 1.4: LOM Production Schedule

Source	Unit	Production Year					Total
		1	2	3	4	5	
SW and 99 Zone production	t	91,000	91,000	91,000	91,000	44,000	408,000
East Zone production	t	0	0	55,000	55,000	95,000	205,000
Total Mine production	t	91,000	91,000	146,000	146,000	139,000	613,000
Mill Head Grades							Average
Zinc mill head grade	%	4.9%	4.9%	10.2%	10.2%	14.6%	9.6%
Lead mill head grade	%	16.6%	16.6%	11.1%	11.1%	6.4%	11.7%
Gold mill head grade	g/t	0.22	0.22	0.34	0.34	0.45	0.33
Silver mill head grade	g/t	1,221	1,221	850	850	542	890

The mine will be accessed from a new decline currently being driven and from the 625 portal (currently being rehabilitated). Personnel and material will be transported in and out of the mine using either the decline or the 625 level.

Economic Analysis

Operating costs on a \$/tonne milled basis are presented in Table 1.5. The project operating costs were estimated from a number of sources including cost estimating guides, contractor and vendor quotes, previous studies and experience. Unit costs for the mill and general and administration (“G&A”) reduce in years 3 to 5 as planned production increases and economies of scale are realized.

Table 1.5: Bellekeno Project Unit Operating Cost Summary (\$/t milled)

Operation (\$/tonne milled)	Year				
	1	2	3	4	5
Mine Operating	79.26	79.26	79.26	79.26	79.26
Mine Development	32.19	52.73	41.18	32.96	34.51
Processing	64.67	64.67	45.91	45.91	45.91
General & Administrative	36.93	36.93	23.08	23.08	23.08
Total Unit Operating Costs	213.05	233.60	189.43	181.21	183.84

Capital costs estimates for the project are shown in Table 1.6. Indirect capital costs for construction were assumed to be 17% of total construction capital. A contingency rate of 25% of total construction capital was also applied. Using these factors, the total construction capital cost was estimated to be \$56.3M. Construction capital costs included associated earthworks, concrete, structural steel, power supply and water supplies. Sustaining capital, made up of mine equipment,

closure costs and exploration development, was estimated to equal \$14.3M. The total capital cost of the project was estimated to be \$70.6M.

Table 1.6: PEA Capital Cost Summary (\$'000)

Capital Costs (\$'000)	Year							Total
	-2	-1	1	2	3	4	5	
Construction Capital								
Mine Equipment		6,768						6,768
Mine Development		2,825						2,825
BK East Advanced Exploration	10,000							10,000
Process Plant & Infrastructure		18,850						18,850
Total Direct	10,000	28,443						38,443
Indirect		6,625						6,625
Contingency (25%)	2,500	8,767						11,267
Initial Working Capital			4,860				-4,860	0
Total Construction Capital	12,500	43,835	4,860				-4,860	56,335
Sustaining Capital								
Mine Equipment			1,020	2,780	676			4,476
Closure Cost		500	250	250	250	250	250	1,750
Exploration Development		1,320	1,360	2,680	2,680			8,040
Total Sustaining Capital		1,820	2,630	5,710	3,606	250	250	14,266
TOTAL CAPITAL	12,500	45,655	7,490	5,710	3,606	250	-4,610	70,601

The pre-tax base case financial model was calculated using the following parameters:

- Mine and mill construction start in 2009 with commissioning in 2010;
- Current advanced exploration costs for Bellekeno of \$10 million included in the initial capital;
- Base case metals pricing is three-year rolling average metal prices;
- Base case three-year average US/Canadian exchange rate;
- Assumed current net smelter terms;
- Five-year mine life;
- SW+99 Zone to commence in Year 1 and East Zone comes on line in Year 3;
- 1.5% NSR royalty capped at \$4.0 million, commencing after payback of capital;
- Resources as per SRK Technical Report dated January 28, 2008;
- Closure and reclamation costs included;
- The model was prepared on a pre-tax basis;
- Working capital recovered in year 5;
- Depreciation costs are not calculated.

The economic evaluation indicates a base case pre-tax internal rate of return (“IRR”) of 55.5% and a pre-tax net present value (“NPV”) of US\$87 million at a discount rate of 8.0% for the Bellekeno deposit. The summary of pricing scenarios and project economics is presented in Table 1.7.

It must be noted that the economic evaluation of the Bellekeno property uses 100% inferred mineral resources. Inferred mineral resources are considered too speculative geologically to have the economic considerations applied to them that would enable them to be categorized as mineral reserves. There is no guarantee that the inferred mineral resources will be upgraded to a higher resource category and there is no certainty that the economic results of this PEA will be realized.

Table 1.7: Economic Evaluation at Various Metal Prices

Parameter	Units	Base Case 3 Year Average ¹	Current Metal Prices ²	Forward Looking Metal Prices and Exchange Rates ³		
Payback Period	years	1.6	1.3	1.4		
IRR (pre-tax)	%	55.5	64	48.5		
NPV at 8% (pre-tax)	US\$Million	87	106.7	57.1		
Prices				2010	2011	2012 and Beyond
Lead	US\$/lb	0.81	0.78	0.70	0.50	0.50
Zinc	US\$/lb	1.24	0.84	1.00	0.90	0.75
Silver	US\$/oz	11.69	17.92	16.00	14.50	12.25
Gold	US\$/oz	625.60	935.25	890.00	780.00	700.00
Exchange Rate	US\$/C\$	0.89	0.98	0.95	0.93	0.90

NOTE:

1. Prices are quoted from London Metal Exchange and are rolling averages through May 2008.
2. Current metal prices as of July 2, 2008
3. Based on Alexco-compiled consensus long-term commodity price and exchange forecasts as of June 19, 2008 as published publicly by a basket of independent Canadian and US investment analysts

The payback period is defined as the time required after revenue is first received in Year 1 to achieve break-even cumulative cash flow. For this project, the payback period for the base case is 1.6 years. The payback period is based on the annual un-discounted cash flows. There is no consideration for inflation, interest, or depreciation in this calculation.

Conclusions

Based on this preliminary economic assessment:

- The testwork results indicate that the tested mineralization responded well to the conventional lead/zinc differential flotation process with a cyanide-free zinc mineral suppression regime.
- Silver and lead minerals associate intimately and will be recovered together to produce a silver-lead bulk concentrate, and zinc minerals will be concentrated into a separate zinc concentrate.

- Narrow-vein mining methods are applicable to the deposit with the final mining modalities requiring geotechnical confirmation.
- Providing that the set out design criteria and assumptions are satisfied, there is a strong indication that the project could be commercially viable.

Recommendations

It is recommended, based on the preliminary positive economic results, that a feasibility study (FS) be conducted on the Bellekeno Project.

The following general recommendations are required to carry the project to a feasibility level:

- Continue to develop underground access for drilling, bulk sampling and mining method testing.
 - Geotechnical recommendations for the development of the access ramp and exploration drifts must be followed.
- Conduct a definition diamond drilling program to attempt to upgrade resources, obtain metallurgical samples and test geotechnical and hydrogeological conditions.
- Conduct trial mining and bulk sampling in the main mineralized zones
- Conduct the necessary feasibility study-level testwork.
- Upgrade all project engineering and costs estimation to a FS level.

It is estimated that the cost to complete the necessary underground development and rehabilitation, drilling and sampling, testing and analysis and the compilation of a feasibility study will be approximately \$12M.

It is also recommended that exploration targets in the Bellekeno area be further explored to determine if additional mineralized zones could be added to the property resources.

2 Introduction

This preliminary economic assessment technical report was prepared for Alexco Resource Corp. by SRK Consulting (Canada) Inc. to provide a preliminary review of the potential economic viability of mining and processing resources from the Bellekeno deposit.

This PEA was compiled by an integrated team of SRK, Alexco and Wardrop personnel with the main non-QP contributors listed in Table 3.1. QPs are shown in Table 2.1. Wardrop’s primary responsibility was the preliminary design and costing of infrastructure, mineral processing and cash flow analyses. SRK’s responsibility was for the resource estimate and mining components. Tim Hall, Manager of Project Development for Alexco provided significant support and information for the mining aspects of the project. Diane Lister of Altura Environmental Consulting (“Altura”), retained by Alexco late 2007 for environmental technical oversight and waste rock management studies, is the QP responsible for section 19.5, Environmental Considerations.

SRK completed a 43-101-compliant mineral resource estimate for the Bellekeno deposit entitled “Mineral Resource Estimation, Bellekeno Project, Yukon Territory, Canada” dated January 28, 2008. The January 2008 SRK report serves as the foundation for this report both in terms of the mineral resource estimate utilized in mine planning and the content of the background information.

The Qualified Persons (“QPs”) responsible for this report inspected the project site on the following dates:

Table 2.1: List of Qualified Persons

Consultant	Company	Site Visit Date
David Keller, P.Geo.	SRK	March 2005 and August 2007
Joe Sedlacek, P.Eng.	SRK	no inspection
Gordon Doerksen, P.Eng.	SRK	January 28 and 29, 2008
Hassan Ghaffari, P.Eng.	Wardrop	April 1, 2008
Diane Lister, P.Eng.	Altura	February 27 and 28, 2008

Ross Greenwood, a non-QP SRK geotechnical consultant accompanied G. Doerksen on the January site visit. The visit included a general tour of the property, inspection of representative diamond drill core, inspection of the Bellekeno 625 level portal (both surface and underground), inspection of the Elsa Mill and review of documentation.

All units in this report are based on the International System of Units (“SI”), except for some units which are deemed industry standards such as troy ounces (oz) for precious metals and pounds (“lb”) for base metals. All currency values are Canadian dollars (“\$”) unless otherwise noted.

This report uses many abbreviations and acronyms common in the mining industry, most of which are defined in the body of the text. Further explanations are located in Section 22.

The economic analysis conducted in this report uses Inferred Mineral Resources exclusively. Inferred Mineral Resources are considered too speculative geologically to have the economic considerations applied to them to be categorized as mineral reserves, and there is no certainty that the inferred resources will be upgraded to a higher resource category or that the results of this preliminary economic assessment will be realized.

3 Reliance on Other Experts

This report relies upon the following information supplied by non-QP experts.

Table 3.1: Non-Qualified Person Contributors

Name and Company	Information
Rob McIntyre, CCEP, Alexco Resource Corp.	Environmental Overview (Section 19.5)

Mr. McIntyre is a Canadian Certified Environmental Practitioner and a Registered Engineering Technologist (Alberta). He has worked for 26 years in northern land and resource development, the past ten years as a Principal of Access Consulting Group. While at Access, Mr. McIntyre developed expertise in environmental management issues in a variety of industrial applications. Mr. McIntyre is a past President and Director of the Yukon Chamber of Mines and is a Member of the Yukon Mineral Advisory Board. Mr. McIntyre's environmental expertise was used for Section 19.5 in which he provides an overview of the main environmental considerations for the project.

SRK and the other qualified persons who have prepared or supervised the preparation of this report have relied on the information provided by Mr. McIntyre in his capacity as a non-QP expert, and do not take responsibility for its accuracy or completeness.

4 Property Description and Location

Information on the property description and location can be found in Section 3 of the report entitled “Mineral Resource Estimation, Bellekeno Project, Yukon Territory, Canada”, January 28, 2008, SRK Consulting (Canada) Inc. filed on the SEDAR website (www.sedar.com). No material change has occurred since the disclosure of the January 28, 2008 SRK report.

5 Accessibility, Climate, Local Resources, Infrastructure and Physiography

Information on the property accessibility, climate, local resources, infrastructure and physiography can be found in Section 4 of the report entitled “Mineral Resource Estimation, Bellekeno Project, Yukon Territory, Canada”, January 28, 2008, SRK Consulting (Canada) Inc. filed on the SEDAR website (www.sedar.com). No material change has occurred since the disclosure of the January 28, 2008 SRK report.

This was actually updated January 28, 2008 to include East Ore. The dates should be changed down the line.

6 History

Information on the property history can be found in Section 5 of the report entitled “Mineral Resource Estimation, Bellekeno Project, Yukon Territory, Canada”, January 28, 2008, SRK Consulting (Canada) Inc. filed on the SEDAR website (www.sedar.com). No material change has occurred since the disclosure of the January 28, 2008 SRK report.

7 Geological Setting

Information on the geological setting can be found in Section 6 of the report entitled “Mineral Resource Estimation, Bellekeno Project, Yukon Territory, Canada”, January 28, 2008, SRK Consulting (Canada) Inc. filed on the SEDAR website (www.sedar.com). No material change has occurred since the disclosure of the January 28, 2008 SRK report.

8 Deposit Types

Information on the deposit type can be found in Section 7 of the report entitled “Mineral Resource Estimation, Bellekeno Project, Yukon Territory, Canada”, January 28, 2008, SRK Consulting (Canada) Inc. filed on the SEDAR website (www.sedar.com). No material change has occurred since the disclosure of the January 28, 2008 SRK report.

9 Mineralization

Information on mineralization can be found in Section 8 of the report entitled “Mineral Resource Estimation, Bellekeno Project, Yukon Territory, Canada”, January 28, 2008, SRK Consulting (Canada) Inc. filed on the SEDAR website (www.sedar.com). No material change has occurred since the disclosure of the January 28, 2008 SRK report.

10 Exploration

Most of the past exploration work in the Keno Hill district was conducted as support to the mining activities until the mines closed in 1989. A good summary of the early exploration work is provided by Cathro (2006). This historic work involved surface and underground drilling designed to explore areas surrounding the main underground working areas. It is beyond the scope of this report to describe all historical exploration work completed in the Keno Hill district. Only the relevant historical work completed at properties of current interest to Alexco is included below.

Alexco's program is the first comprehensive exploration effort in the district since 1997. During the initial phase of Alexco's involvement at Keno Hill, a program of geologic data compilation, aerogeophysical surveying (conducted by McPhar Geophysics) and surface diamond drilling was completed.

Past operator, Untied Keno Hill Mining ("UKHM"), accumulated a huge number of paper maps and documents relating to nearly seventy years of district mining, but the documentation and data were never assembled into a coherent database that could be used to decipher the geology on a district scale. Beginning in late 2005 and continuing throughout 2006 and 2007, Alexco has converted over 100 gigabytes of this historic data to digital form by scanning and data entry.

Two diamond drilling rigs were initially mobilized to the district during the summer of 2006 and forty-two drill holes were completed for the season totalling 11,180 metres. The holes were primarily directed toward verification and extension of historic resources at Bellekeno, Husky SW and Silver King. A few widely spaced holes were also drilled on other targets considered promising such as Silver King East and Lucky Queen. As a routine procedure, all diamond drill core sampled was analyzed for thirty-three elements with analyses of these geochemical data being used to gain a better understanding of the distribution of mineralizing fluids on both a district and local scale.

Diamond drilling resumed in March of 2007 with emphasis again being placed on Bellekeno, Husky SW and the Silver King/Silver King East areas. In addition, targets were drilled on several under-explored veins in the vicinity of Elsa town site. Lucky Queen was revisited and the Onek mine area saw substantial amounts of work. During 2007, approximately 21,754 metres of drilling was completed on the Keno Hill project in eighty-five boreholes. Forty of those boreholes (12,944 metres) were drilled to explore the Bellekeno Southwest and East Zones.

Three geophysical techniques have been used over parts of the property; aeromagnetic, aeroelectromagnetic and ground IP (induced potential). The high quality results generated by these surveys were successful in helping to identify possible hidden structures and covered stratigraphy. There is, however, no obvious signature unique to known mineralization. During 2007, a ground IP geophysical survey was completed on the Husky SW to Silver King trend by contractor Aurora Geoscience.

11 Drilling

11.1 Historical Drilling

Available information about historical drilling is probably incomplete but reaches back to 1974 for the Husky SW area and to 1975 for the Bellekeno area.

For the Bellekeno area, historical drilling information is available from 1975 onwards. UKHM and Watts Griffis McQuat (“WGM”) drilled a total of 13,006 metres, consisting of underground and surface holes. Both companies drilled diamond drill holes as well as percussion or reverse circulation holes. Very little information is available about azimuths and dips of these historical holes. Hence, no information about intersected mineralization and its true thickness is available.

SRK briefly reviewed and discussed with former UKHM staff drill core sampling procedures that had been undertaken during mine operations. Surface and underground diamond and percussion drilling was completed by UKHM for the Bellekeno deposit. Chip sampling was conducted along mining drifts and raise for the Bellekeno East and 99 veins and to a limited extent in the Southwest Zone.

Diamond drilling procedures used by UKHM appear to be reasonable based on limited information about historical procedures. UKHM reported significant losses of silver mineralization in the course of drilling as finely mineralized sulphosalts were washed out of core material by drilling fluids. To accommodate this problem, drill hole assays were augmented by sludge samples to adjust for this loss during the estimation of historical resources. Sludge samples are affected by many factors from drilling technique to mud density and the size, shape and weight of drill cuttings. SRK considers sludge samples as poor quantitative indicator of metal losses.

Historical percussion drilling drill cuttings were assayed and analysed to determine grade and contacts of mineralization. UHKM used procedures such as:

- Logging of penetration rates and drill fluid colour to assist identification of mineralized zones;
- Flushing of hole after each 4-foot sample interval to reduce “run-on” contamination; and
- Careful analysis of chip samples under binocular microscope to identify first appearance of mineralized and unmineralized lithologies.

Despite the procedures, percussion samples are considered by SRK to be fundamentally biased because they do not represent a continuous and regular volume of rock. Sample contamination from percussion hole sidewalls remain a possibility despite flushing the hole between 4-foot samples.

Historical chip sampling has been established in the mining industry as a sampling procedure prone to bias. Bias in chip sampling can result from many sources but the primary bias results from a discontinuous and irregular volume of rock taken along the sampled surface. Other sources of error

may result from sampler bias where only mineralized surfaces or surfaces that are easy to chip are sampled.

11.2 2006/2007 Alexco Drilling

Alexco conducted surface diamond drilling programs in 2006 and 2007. The 2006 campaign, starting in July and ending in December, consisted of forty-two drill holes totalling 11,180 metres. The 2007 campaign consists of eighty-five boreholes totalling 21,754 metres.

At the Bellekeno Mine, nine (3,727 m) and thirty-one (9,217 m) core boreholes targeted the Number 48 vein structure in 2006 and 2007, respectively. Other core boreholes were drilled in the Bellekeno area during 2007 but they are not relevant for this technical report.

In 2006, diamond drilling was performed by Peak Diamond Drilling based out of Courtney, British Columbia utilizing two skid mounted drill rigs, a LF-70 drill and an EF-90 drill. Drilling was done by the wireline method using N- size equipment (NQ2). In 2007 diamond drilling was performed by Quest Diamond Drilling based out of Abbotsford, British Columbia utilizing four skid mounted drill rigs, two LF-70 drills and two LF-90 drills. Drilling was done by the wireline method using H-size equipment (HQ). For both campaigns the drilling was well supervised, the drill sites were clean and safe, and the work was efficiently done. Diamond drill operational safety inspections were conducted on each drill rig at various times throughout the drilling programs.

For the majority of the drill program, roads and trails constructed by previous mining and exploration programs were utilized to access drill sites. Approximately 1,000 m of new access roads were constructed to reach drill sites.

Drill hole collars were located respective to UTM coordinates. Proposed drill hole collars were located using a Garmin GPS. Final and completed collars were surveyed with an Ashtech GPS utilizing post-processing software for +/- 0.1 metre accuracy. Final coordinates were also recorded in the UTM coordinate system.

Drill holes ranged in length from 67 m to 600 m, averaging 259 m. Most holes were drilled on a north westerly azimuth with a declination of between 40° and 90°. In most cases the drill holes were designed to intercept the mineralized zones perpendicular to the strike direction to give as close as possible a true thickness to the mineralized interval. Down hole surveys were taken approximately every 60 m (2006) or 30 m (2007) using a reflex survey tool.

Standard logging and sampling conventions were used to capture information from the drill core. The core was logged in detail using paper forms with the resulting data entered into a commercial computerized logging program either by the logging geologist or a technician. Four sets of data were captured in separate tables: lithology and structure, mineralization, alteration and geotechnical. Any remarks were also captured. Lithology was documented by a 1 to 4- letter alphanumeric code with additional modifiers. Structural data consisting of type of structure and measurements relative to core axis were recorded within the lithology table. The mineral table captured visual percentage

veining (by type), sulphide (galena, sphalerite, pyrite, arsenopyrite, stibnite, chalcopyrite, freibergite and native silver), and oxide (limonite, sulphosalts and wad). Specific alteration features including silica, carbonate and FeO_x alteration were also captured using a qualitative weak to strong scale. The geotechnical table records percentage recovery and rock quality determination for the entire hole and fracture intensity where warranted. Specific gravity, magnetic susceptibility and point load test were performed on selected holes.

Drill core was found to be well handled and maintained. Data collection was competently done and found to be consistent from hole to hole and between different core loggers.

12 Sample Method and Approach

12.1 Historical Exploration and Sampling

Information about the historical sampling approach, methodology and quality control is limited but some information could be retrieved from old documents. SRK believes that, in most cases, data and documentation suffice to verify assay results in order to include these historical data in this resource estimation.

A 1965 UKHM document outlines the sampling procedures for a newly purchased percussion drill. It was found that in most cases the frozen ground gave sufficient support for the drill hole without additional casing. In a few cases where the ground was not frozen, casing was advanced with the drill bit.

Drill cuttings were collected using a locally designed cone-shaped deflector with a catch pan shaped to fit around the casing. During drilling operations, cuttings were blown upwards between the drill rod and the casing, hit the deflector and were caught by the catch pan. Runs were 1.5 metres in length, and provided 4.5 to 6.8 kg of sample material. At the end of each shift several hundred grams were split from each sample in the geochemical laboratory; the remainder of the sample material was screened to -14 mesh. Constituents of the fine and coarse fraction were identified separately.

Two separate documents dated 1974 and 1994 by WGM outline sampling procedures for the reverse circulation drilling. Two samples were to be collected for each 1.5 m interval. One sample was sent to the laboratory while the other sample stayed at the drill for reference. The samples were collected in porous plastic bags and were dried prior to analysis. The document stresses cleanliness during the sampling procedure in order to avoid contamination.

A 1996 UKHM "Geological Procedure" manual outlines the core sampling procedure. Once the core was logged, the geologist was to mark sample intervals on the core with a crayon and blue flagging. The core was then photographed with footage tags clearly visible and lithological contacts clearly marked by flagging. Sample bags were marked with the sample tag number and two sample tags were to be placed in the bag (one tag stayed with the reject the other with the pulp). Following sample bag preparation the core was split so that half of the core could be retained. All samples from one hole were listed on a sampling record sheet of which copies were distributed to the Chief Geologist and the bucking room.

The manual also contains underground chip sampling guidelines. Geologists were urged to sample all active faces of advancing workings that contained vein material in order to obtain a complete record of grade distribution. Individual chip sample length was not to exceed 0.90 m but no minimum length was listed. If possible vein material was to be sampled separately from wall rock. Total sample length had to be at least 1.5 m, representing the minimum mining width. In case of

small parallel veins, wall rock between individual veins was sampled separately to a minimum width of 0.3 m. A typical sample size was approximately 2 kg.

An undated UKHM document outlines underground chip sample procedures as well. In addition to the above information, emphasis is put on clean faces in order to prevent sample contamination from previous blasting activities. Samples were to be taken within a 0.5 m wide area across the rock face. In addition to separate samples per rock type, this undated document requires separate samples for a change in structure. The sample location was to be measured from the nearest survey station; the resulting distance measurement was used to plot the samples (and assay results) on level plans. More detailed information was listed regarding the direction in which samples were to be taken for various kinds of underground openings.

Historical silver assays were primarily analysed using XRF techniques. Quality control procedures described for the lab included routine submission of blanks, duplicates, and spike samples. Independent tests with outside labs are noted in documents starting in the 1980s but cannot be substantiated by SRK. A document details procedures for the preparation of samples for atomic absorption assaying. A sample amount of 200 mg was used to analyze for silver, lead, zinc, cadmium, and copper. Very limited historical re-assay data for diamond drill core and chip samples indicate a reasonable correlation for silver analysis. Reviewed quality control data includes re-assay data reported until the 1980s.

After review and analysis of historical diamond drill hole data, SRK is of the opinion that the historical diamond drilling sample data are generally reliable for the purpose of estimating mineral resources. However chip sample assay data are considered to be appropriate for use in variography but not for grade estimation. SRK considers that percussion drilling data are inappropriate for resource estimation because of the unreliable and biased nature of this type of sampling.

12.2 Alexco 2006 and 2007 Exploration and Sampling Programs

Alexco surveys all borehole collars as well as the borehole path. Surveying data is acquired using differential GPS and stored in both mine grid and UTM grid systems. Downhole surveys are acquired using standard Easy Shot readings on thirty to sixty-meter intervals. For the current program, downhole surveys suggest that in general borehole trajectories deviate much more than initially anticipated. It may be wise to test the downhole deviation data with another monitoring device to ensure that the Easy Shot readings provide a reliable estimate of the borehole trajectories, especially for the longer course drill holes.

The sampling protocol for both the 2006 and 2007 Alexco programs has been the same. The logging geologist marks the sample intervals on the core. Samples are typically 2 m in length within major rock types. Sample intervals are broken at lithological contacts and at significant mineralization changes. Sample intervals within mineralized zones range from 0.10 m to 1.0 m, based on consistency of mineralization. In 2006, boreholes were sampled top to bottom, while in 2007 some

intervals of barren material were not sampled for holes in close proximity to boreholes that were sampled continuously.

After logging, the core is digitally photographed and sawn in half lengthwise with a diamond saw. Attention is paid to core orientation. One half is returned to the core box for storage at site and the other bagged for sample shipment. No further on-site processing is performed. Alexco inserts blank, duplicate and standard control samples into the general sample stream. The location of control samples in the sample stream is defined by the logging geologist. Control samples consist of commercial Standard Reference Material (“SRM”), a blank and a duplicate for each batch of twenty samples submitted for assaying.

13 Sample Preparation, Analyses and Security

13.1 Historical Samples

Information regarding historical assay procedures reviewed by SRK was limited. Reviewed reports and documents provide only a general description of assay techniques and procedures. Equipment at the mine laboratory in Elsa included two atomic absorption instruments, a fire assay unit and a colorimetric wet lab. SRK understands that only gold was fire assayed. Silver was analysed by XRF analysis with lead and zinc analyses conducted using titration methods.

13.2 Alexco 2006 – 2007 Exploration Programs

The sample shipment procedure for 2006 and 2007 is generally the same except where noted. Approximately four to five individual samples are placed in rice bags (grain sacks) for shipment. Beginning in 2007 each rice bag was sealed with a numbered security tag. Bags are then placed on pallets and wrapped for shipping. In 2006 samples were sent to Whitehorse, Yukon via Kluane Transport then to the ALS Chemex facility in North Vancouver, British Columbia for preparation and analysis via Manitoulin Transport. In 2007 samples were transported to the Canadian Freightways facility in Whitehorse, Yukon by Alexco personnel. Canadian Freightways then trucked the samples to the ALS Chemex facility in Terrace, British Columbia for preparation. Pulverized sub-sample splits were then sent to the ALS Chemex facility in North Vancouver, British Columbia for analysis.

The ALS Chemex North Vancouver laboratory is accredited to ISO 17025 by Standards Council of Canada for a number of specific test procedures, including fire assay for gold and silver with atomic absorption and gravimetric finish, multi-element inductively coupled plasma optical emission spectroscopy and atomic absorption assays for silver, copper, lead and zinc. ALS-Chemex laboratories also participate in a number of international proficiency tests, such as those managed by CANMET and Geostats.

Sample preparation and analyses is consistent for both the 2006 and the 2007 Alexco programs.

Sample preparation (method code Prep-31) consists of initial fine crushing of the sample to better than seventy percent passing two millimetres. A nominal 250 g split of this material is then pulverized to greater than eighty-five percent passing seventy-five micron for analyses. Duplicate samples are prepared by preparation facility by collecting a second 250 g split from the crushed material taken from the preceding sample when noted.

Samples are analyzed for gold by fire assay and atomic absorption spectrometry (method code Au-AA25) on thirty gram sub-samples and for a suite of twenty-seven elements by four acid digestion and inductively coupled plasma atomic emission spectroscopy (“ICP-AES”; method code ME-ICP61) on 0.5 g sub-samples. Elements exceeding concentration limits of ICPAES were re-assayed

by single element four acid digestion and atomic emission spectroscopy (method code element-AA62). Silver results exceeding ICP-AES limits are re-assayed by fire assay and gravimetric finish (method code Ag-Grav21) on thirty grams sub-samples.

13.3 Quality Assurance and Quality Control Programs

Quality control measures are typically set in place to ensure the reliability and trustworthiness of exploration data. This includes written field procedures and independent verifications of aspects such as drilling, surveying, sampling and assaying, data management and database integrity. Appropriate documentation of quality control measures and regular analysis of quality control data are important as a safeguard for project data and form the basis for the quality assurance program implement during exploration.

Analytical control measures typically involve internal and external laboratory control measures implemented to monitor the precision and accuracy of the sampling, preparation and assaying. They are also important to prevent sample mix-up and monitor the voluntary or inadvertent contamination of samples. Assaying protocols typically involve regular duplicate and replicate assays and insertion of quality control samples to monitor the reliability of assaying results throughout the sampling and assaying process. Check assaying is typically performed as an additional reliability test of assaying results. This typically involves re-assaying a set number of sample rejects and pulps at a secondary umpire laboratory.

13.3.1 Historical Exploration

Historical silver assays were primarily analyzed using XRF techniques. Quality control procedures described for the lab included routine submission of blanks, duplicates, and spike samples. Independent tests with outside labs are noted in documents starting in the 1980s but cannot be substantiated by SRK. A document details procedures for the preparation of samples for atomic absorption assaying. A sample amount of 200 milligram was used to analyze for silver, lead, zinc, cadmium, and copper. Very limited historical re-assay data for diamond drill core and chip samples indicate a reasonable correlation for silver analysis. Reviewed quality control data includes re-assay data reported until the 1980s.

After review and analysis of historical diamond drill hole data, SRK is of the opinion that the historical diamond drilling sample data are generally reliable for the purpose of estimating mineral resources. However chip sample assay data are considered to be appropriate for use in variography but not for grade estimation. SRK considers that percussion drilling data are inappropriate for resource estimation because of the unreliable and biased nature of this type of sampling.

13.3.2 Alexco 2006 and 2007 Exploration Programs

Alexco surveys all borehole collars as well as the borehole trajectory. Surveying data is acquired using differential GPS and stored in both mine grid and UTM grid systems. Downhole surveys are acquired using standard Easy Shot readings on thirty to sixty- meter intervals. For the current

program, downhole surveys suggest that in general borehole trajectories deviate much more than initially anticipated. Downhole deviation data should be tested with another monitoring device to ensure that the Easy Shot readings provide a reliable estimate of the borehole trajectories, especially for the longer course drill holes.

Alexco inserts blank, duplicate and standard control samples into the general sample stream. The location of control samples in the sample stream is defined by the logging geologist. Control samples consist of commercial Standard Reference Material (“SRM”), a blank and a duplicate for each batch of twenty samples submitted for assaying.

Alexco used one of seven SRM (Table 13.1) purchased from WCM Sales Limited of Burnaby, British Columbia: three polymetallic copper, lead, zinc and silver reference material (PB112, PB113 and PB116) and four silver reference materials (PM1107, PM1108, PM1116 and PM1117) for inclusion of each twenty sample batch.

Table 13.1: Commercial Standard Reference Material Used by Alexco for the 2006 and 2007 Drilling Programs.

SRM		Cu (%)	Pb (%)	Zn (%)	Ag (g/t)	Ag (oz/t)
PB112	Recommended	0.85	0.92	1.27	222	
	std. deviation	0.01	0.02	0.03	2	
PB113	Recommended	0.47	1.11	1.40	22	
	std. deviation	0.01	0.02	0.05	1	
PB116	Recommended	0.43	1.40	0.85	22	
	std. deviation	0.01	0.06	0.02	1	
PM1107	Recommended				1194	38.39
	std. deviation				34	1.1
PM1108	Recommended				658	21.16
	std. deviation				10	.33
PM1116	Recommended				22.4	.72
	std. deviation				0.7	0.02
PM1117	Recommended				11.3	.36
	std. deviation				0.5	0.1

Control samples were inserted when the core is sawn. The SRM is already processed to a pulp and is inserted as ~50-100 gram amounts. The blank is commercially purchased “landscape rock”, either dolomite or basalt. Approximately 350 grams to 1.5 kilograms of this material is inserted. An empty sample bag is inserted at the location of the duplicate which is prepared during sample preparation at the ALS Chemex prep facility. The duplicate consists of a coarse reject split of the preceding sample.

The quality control program developed by Alexco is mature and overseen by appropriately qualified geologists. In the opinion of SRK, the exploration data collected by Alexco on the Keno Hill project was acquired using adequate quality control procedures that generally meet or exceed industry best practices for a resource delineation stage exploration property.

14 Data Verification

14.1 Verifications by Alexco

During almost 100 years of exploration and mining in the Keno Hill area a large amount of data and documents were produced; much of this material is accessible to Alexco.

All accessible diamond drill hole logs were transcribed onto a standardized spreadsheets as close to verbatim as possible; the original logs were scanned and file names and numbers were recorded in the new spreadsheets as well. These first spreadsheets were then inspected by geologists for consistency. The next step was to “normalize” the original transcribed data in order to match current nomenclature; data verification was ongoing. Collar information, as well as survey, assay and recovery data were then verified by a person other than the original data entry person; the final step was to amalgamate separate spreadsheet into one global database.

Large amounts of data were scanned by Alexco; however, documents were labelled with the location (e.g. file cabinet number and drawer) before being moved from the storage sites to the scanning facility. The scans of large maps and sections are stored as image files (jpeg format) where the file name contains original title block information. Individual files are stored in directories that mimic the physical storage location. Smaller maps and reports were scanned and saved as Adobe® pdf files. Naming convention and file hierarchy are the same as for the large maps. Each file is also given a five digit number that is added in front of the file name. These numbers are listed in an Excel spreadsheet that also contains the file name, the file extension, the file size, the scanning date as well as the directory location. Finally, scans are reviewed and a key word index is created for each file.

14.1.1 Site Visit

In accordance with NI43-101 guidelines, SRK visited the Keno Hill project on several occasions between March 2005 and August 2007 while active drilling was ongoing. The purpose of the site visits was to inspect and ascertain the geological setting for the Bellekeno and other projects, witness the extent of exploration work carried out on the property and assess logistical aspects and other constraints relating to conducting exploration work in this area. SRK visited several active and recent drilling sites.

SRK reviewed with Alexco personnel the historical work carried out at Bellekeno, including archived drawings, drill logs and assay sheets. SRK also reviewed the methodology used by former Bellekeno mine personnel to estimate mineral resources.

SRK examined core from selected boreholes drilled by Alexco at Bellekeno. SRK also interviewed NovaGold personnel about field procedures and geological interpretation derived from the exploration drilling.

SRK was given full access to project data. In the opinion of SRK, the exploration work carried out by Alexco is conducted under the supervision of appropriately qualified personnel using procedures that meet or exceed industry best practices.

14.1.2 Verification of Historical Data

SRK did not conduct extensive verifications of historical data because of the extent of the verifications completed by Alexco as part of the digitization of the archived paper records. By nature much of this information is difficult to verify, but SRK has no reason to believe that this information is unreliable.

SRK has reviewed the limited quality control data available for the historical assays, as made available by Alexco.

Quality control data exists for underground sample duplicate assays collected between 1984 and 1988. Duplicate assays were performed at a rate of 12% (1 in 8.5 samples) for the chip samples and at a rate of 5% (1 in 20 samples) for grab samples. The duplicate sample database contains 319 chip samples silver assay pairs that were analyzed by SRK using bias charts (see November 2007 technical report). Except for a small number of outliers, reproducibility from the chip samples is acceptable as the majority of duplicate samples are within ten percent of the original assay value.

14.1.3 Verification of Alexco Data

Alexco made available to SRK the complete electronic data accumulated on the Bellekeno project in the form of a Microsoft Access® database. This database contains the drilling data for seventy-one core boreholes drilled in the Bellekeno Mine, including twenty-five boreholes drilled in 1995 and 1996 and forty-nine boreholes drilled by Alexco in 2006 and 2007.

SRK conducted a series of routine verifications to ensure the reliability of the electronic data provided by Alexco. SRK audited assay results for two boreholes (K06-016 and K07-037) against original assay certificates. Approximately ten percent of the 2006 and 2007 assay data were also checked at random against original assay certificates. This audit uncovered a low level of data entry errors. These errors were corrected. Other minor labelling issues uncovered by SRK were also fixed by Alexco personnel. In the opinion of SRK, the electronic data are reliable, appropriately documented and exhaustive.

The quality external analytical quality control data produced by Alexco during 2006 and 2007 is summarized in Table 14.1.

Table 14.1: Quality Control Data Produced by Alexco in 2006 and 2007.

Quality Control Type	Count	Ratio
Core Samples (2006-2007)	7,338	
Blanks	455	6%
Standard Reference Material	456	6%
Coarse Reject Duplicate	457	6%
Pulp Replicate	567	8%

Between January 2007 and January 2008, SRK periodically reviewed the analytical quality control data produced by Alexco. SRK aggregated the assay results for the external quality control samples and pulp replicate assay pairs. Time series, bias charts and relative precision plots were constructed by SRK for silver, zinc and lead assay pairs. The charts are presented in Appendix B.

SRK uncovered a number of potential failures of quality control samples (see Appendix B). Each potential failure was investigated by Alexco and appropriate remedy action were taken, including the re-assaying of batches containing abnormal quality control samples. In some instances the potential failures occurred in batches of samples outside potentially mineralized areas. In such cases no remedy actions were taken.

Analysis of bias charts and precision plots (Appendix B) suggest that silver, lead and zinc grades can be reasonably reproduced from the same pulp of the coarse reject samples with no apparent bias. Duplicate and replicate sample pairs examined exhibit reasonable precision as measured as a percentage of the half relative deviation from the mean of the pair (“HRD”). Pairs with HRD number greater than twenty or thirty percent are generally from samples assaying close to the detection limit for that metal (Appendix B).

In the opinion of SRK, the quality control data collected by Alexco is comprehensive and despite the difficulties with some standards used, the assaying results delivered by ALS-Chemex is generally reliable for the purpose of resource estimation.

15 Adjacent Properties

As of February 13, 2008 Alexco has an agreement with Bardusan Placer Ltd. to construct and use a temporary road for activities related to Alexco Claims in the area that overlaps Bardusan owned placer claims.

There are no other adjacent properties considered relevant to this technical report.

16 Mineral Processing and Metallurgical Testing

16.1 Testwork Review

16.1.1 Background

Although there is a long history of operation with the processing of ores from different mines at the Elsa Mill, including that of the Bellekeno deposit, historical testwork related to Bellekeno mineralization prior to 1996 could not be located. An earlier Feasibility Study by Rescan Engineering Ltd. (Rescan) summarized historical operation data.

The Elsa Mill operated between 1949 and 1989 to process various ores from many different mines in the Keno Hill District. Mineralogy of mill feeds varied substantially due to different types of mineralization throughout the district. Before the closure of the Hector-Calumet Mine in October 1972, the Elsa Mill produced both a silver-lead concentrate and a zinc concentrate. In the later operation period, the mill produced silver-lead concentrate only due to much lower zinc feed grades and lower metal prices.

16.1.2 Testwork Programs

The historical operation data are summarized in Table 16.1.

Table 16.1: Historical Operation Data

Period	Concentrate	Assayed Concentrate Grades			Recovery (Total metal recovery % reporting to each concentrate)		
		Ag (g/t)	Pb (%)	Zn (%)	Ag (%)	Pb (%)	Zn (%)
1950s	Silver-Lead	9,454	71.3	3.6	89	93	5
	Zinc	404	0.8	56.3	5	1	88
1970s	Silver-Lead	16,950	60.6	7.3	92	88	37
	Zinc	1431	1.4	48.9	1	-	38
1980s	Silver-Lead	7,122	42	4.2	85	75	40
	Zinc	-	-	-	-	-	-
Average # 1936-1986	Silver-Lead	-	-	-	*	85.2	-
		-	-	-	*	47.2-96.8	-
	Zinc	-	-	-	*		85.7
		-	-	-	*		32.2-96.0

* Overall silver recovery averaged 91.4%, ranging 79.0% to 98.3%.

From various historical reports provided by Alexco

An earlier Rescan Feasibility Study listed six metallurgical test work reports:

- Microscopic Examination of Zinc Concentrate, Lakefield Research (1973);
- Investigation of Recovery of Lead and Silver from 'Shamrock' Ore Sample, Lakefield Research (1975);
- Investigation of Recovery of Lead and Silver from UKHM Ore Sample, Lakefield Research (1976);
- Investigation of the Filtration Characteristics of a Lead-Silver Concentrate from UKHM, Lakefield Research (1978);
- Investigation of Recovery of Silver from UKHM, Lakefield Research (1979);
- Metallurgical Testing on the Bellekeno and Silver King Ores, Process Research Associates Ltd. (PRA) (1996).

Two of the above reports, prepared in 1979 and 1996, were available for the review.

The 1996 test work by PRA was used as the basis for the Rescan Feasibility Study. The test program focused on a blend composite sample consisting of 85% Bellekeno and 15% Silver King ore. The testing also investigated the metallurgical responses of individual Bellekeno and Silver King samples.

The most recent test program was conducted in 2007 by SGS-Lakefield Research (Lakefield). The tests evaluated the metallurgical performance of a composite representing Bellekeno mineralization. Process mineralogical examination was also performed on a head sample using the QEMSCAN™ technique.

Since the mineralization for the currently proposed process plant may differ from the samples used for the test work prior to 1986, the review focuses on the 1996 PRA and 2007 SGS test programs only.

16.1.3 Test Samples

1996 Test Samples

In 1996, three samples; Bellekeno (BK), Silver King (SK) and BK/SK (85%/15%) composites were generated for metallurgical testing. The blended BK/SK composite was used for preliminary process condition optimization tests.

The head assays of the composites are shown in Table 16.2. The overall grades of the 1996 PRA test work samples are consistent with the SW and 99 zones in the Bellekeno deposit.

Table 16.2: Head Assays – 1996 Test Samples

Sample	Au (g/t)	Ag (g/t)	Cu (%)	Fe (%)	Pb (%)	Zn (%)	S (%)	C (%)
BK Comp	0.40	990	0.092	6.81	14.6	6.48	7.19	0.11
SK Comp	0.70	1,219	0.048	4.27	4.46	0.041	4.84	0.74
BK/SK Comp	0.55	1,119	0.084	5.86	13.6	4.51	6.32	0.25

2007 Test Samples

The 2007 composite sample was produced from 31 drill core samples from recent 2006-2007 Alexco core drilling at the Bellekeno deposit. More details on the sample description are provided in the 2007 test work report by SGS. Chemical analysis on the master sample is provided in Table 16.3. Compared to the 1996 samples, the sample contained a significantly high amount of zinc.

Table 16.3: Head Assay – 2007 Test Sample

Sample	Au (g/t)	Ag (g/t)	Cu (%)	Fe (%)	Pb (%)	Zn (%)	S (%)	S ² (%)
BK Comp	0.96	1,152	-	12.7	11.8	11.2	9.69	9.62
BK Comp (dup)	1.15	1,210						

The QEMSCAN™ mineralogical examination indicated that lead occurred as galena (PbS) and zinc as sphalerite ((Zn, Fe)S). Pyrite was identified as a minor sulphide (3.8% of total mass) and trace sulphide minerals included chalcopyrite, bornite, chalcocite, tetrahedrite, and arsenopyrite. Non-sulphide minerals were mainly quartz (30.5% of total mass) and manganese-bearing siderite (27.6% of total mass). Other non-sulphide minerals identified include micas, feldspars, chlorites, and clays.

16.1.4 Grindability Tests

Both test programs conducted in 1996 and 2007 determined sample hardness. The test results from Lakefield indicated that the standard Bond ball mill work index at the closing mesh size of 106 µm was 9.5 kWh/t for the Bellekeno composite. The hardness was within soft to medium-soft range according to the SGS database.

PRA measured the material hardness of the BK and SK composites as well as four individual samples. At the closing mesh size of 150 µm, the obtained Bond ball mill work indices were 9.3 kWh/t for the BK composite and 10.3 kWh/t for the SK composite.

Both sphalerite and galena liberated at a relative coarse grind size. At a grind size of P₈₀ 170 µm, 96.5% of the sphalerite and 95.4% of galena were present as liberated phases. It appears that some of the sphalerite and galena associated closely with siderite.

16.1.5 Flotation

Bench Open Cycle Tests

Primary Grind Size

The 2007 test work investigated the effect of primary grind size on metallurgical performance. The relationship between lead and zinc recoveries and mass recovery at the lead rougher flotation stage are summarized in Figure 16.1. Although finer primary grind size would slightly improve lead and zinc metallurgical performance, the effect of primary grind size was not significant. Lakefield used 80% passing 175 μm as the primary grind size for the locked cycle tests.

Figure 16.1: Lead and Zinc Recovery at Lead Rougher Flotation vs. Mass Pull

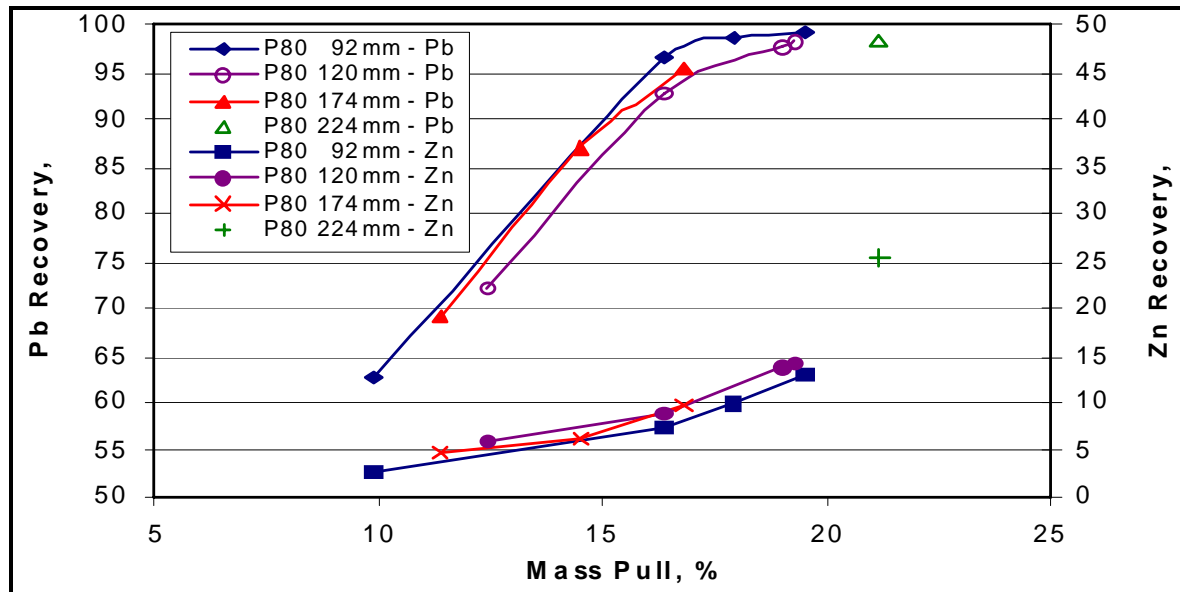

For zinc flotation, Lakefield indicated that zinc rougher flotation recovery was not affected by primary grind size (up to 80% passing 174 μm).

In the 1996 test work, no primary grind size was optimized. All tests were conducted at a relatively coarse primary grind size, targeting 45% passing 74 μm .

Collector – Lead Flotation

The 2007 test program investigated the effect of mineral collectors on lead flotation. The tested collectors included 3418A, A242, and sodium isopropyl xanthate (SIPX). The tests were conducted at the primary grind size of 80% passing 92 μm using 400 g/t soda ash (Na_2CO_3) to control pH and 200 g/t ZnSO_4 and sodium cyanide (NaCN) complex (150 g/t ZnSO_4 and 50 g/t NaCN) to suppress zinc minerals. The test results are summarized in Figure 16.2.

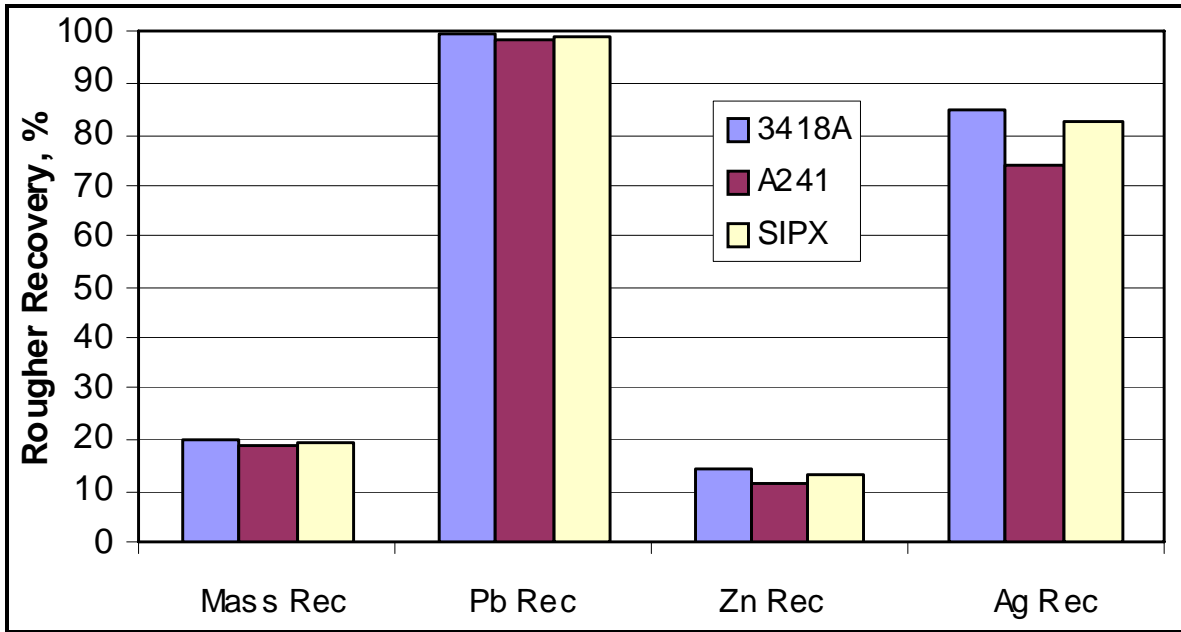

Figure 16.2: Effect of Collectors on Lead, Zinc, and Silver Recovery at Lead Rougher Flotation

The collector screening tests generated very similar metallurgical responses for lead and zinc. However, it appears that silver did not respond well to A241 compared to 3418A and SIPX. Lakefield selected SIPX as lead mineral collector for further testing because the reagent is inexpensive compared to the other two reagents.

The test program in 1996 employed 3418A or 3418A in conjunction with sodium ethyl xanthate (SEX) as lead mineral collectors. The test results showed no benefit to lead recovery by using the combined collector regime.

Collector – Zinc Flotation

Both test programs employed conventional collectors for zinc flotation. The 1996 test program used PAX for zinc flotation, while the 2007 test program employed SIPX. It appears that zinc flotation responded well and similarly to the reagents.

Zinc Mineral Suppressants

The 2007 test program investigated the effect of two zinc mineral suppression regimes on lead rougher flotation. One was zinc sulphate (ZnSO₄, 150 g/t) alone and the other was zinc sulphate in conjunction with NaCN (150 g/t ZnSO₄ + 50 g/t NaCN).

The test results indicated over 25% of the zinc reported to lead rougher flotation concentrate when using ZnSO₄ alone, compared to approximately 10% of the zinc in the lead rougher concentrate with adding the ZnSO₄/NaCN complex. According to the test results, Lakefield employed the ZnSO₄/NaCN complex for further testing.

It appears that further tests should be conducted to optimize zinc suppression by cyanide-free regimes. Normally ZnSO₄ in conjunction with sodium sulphite (Na₂SO₃) or sodium metabisulphite (Na₂S₂O₅, MBS) would produce an effective separation between lead and zinc minerals.

The 1996 test program used a combination of ZnSO₄/Na₂SO₃ for zinc mineral suppression during lead flotation. The test results indicated that the suppression regime could effectively depress the flotation of zinc minerals. The reagent dosage was 600 grams per tonne for ZnSO₄ and Na₂SO₃, respectively.

Regrind – Lead Cleaner Flotation

Both of the test programs investigated the effect of regrind particle size on lead cleaner flotation. The 2007 test program appeared to show that regrinding lead rougher concentrate down to 80% passing 15 µm did not significantly improve the metallurgical performance, compared to a regrind particle size of 80% passing 32 µm.

The 1996 test program also studied the effect of regrind size on the metallurgical response of lead rougher flotation. The regrinding test results of the lead flotation circuit are presented in Table 16.4. The results clearly show that regrinding of the lead rougher concentrate substantially improves lead and silver recoveries and concentrate quality. Mineralogical examinations indicated that 92% of the zinc minerals in the lead cleaner scavenger concentrate was associated with other minerals when not reground (Test 7).

The particle size of the lead cleaner concentrate from Test 8 was 96.8% passing 37 µm; this might not be the optimum regrind size for lead and zinc mineral liberation. Further tests to optimize regrind size should be undertaken.

Table 16.4: Regrind Test Results – 1996 Test Program

Test	Product	Mass Recovery (%)	Grade		Recovery		
			Pb (%)	Zn (%)	Pb (%)	Zn (%)	Ag (%)
Test 7 without regrind	1st Cl. Conc.	11.1	58.6	6.5	55.8	17.7	68.7
	1st Cl. + Sc. Conc.	17.4	60.9	5.9	90.8	25.2	91.3
	Pb Rougher Conc.	19.2	58.8	5.6	96.9	26.4	96.4
Test 6 with regrind	1st Cl. Conc.	16.2	72.0	1.9	93.7	7.0	93.7
	1st Cl. + Sc. Conc.	18.5	65.1	3.0	95.6	12.8	95.6
	Pb Rougher Conc.	22.6	54.4	3.5	97.0	18.6	97.0
Test 8 with regrind	2nd Cl. Conc.	14.9	74.8	1.0	87.5	3.1	90.6
	1st Cl. Conc.	15.9	72.3	1.4	90.3	4.7	92.4
	Pb Rougher Conc.	19.3	63.5	2.8	96.0	11.3	95.6
Test 9 with regrind	2nd Cl. Conc.	19.0	71.4	1.8	91.4	6.1	93.3
	1st Cl. Conc.	20.5	68.4	2.7	94.2	9.8	94.9
	Pb Rougher Conc.	24.9	58.2	6.1	97.4	26.6	96.8

Regrind – Zinc Cleaner Flotation

Both test programs from 1996 and 2007 investigated the effect of regrinding on zinc cleaner flotation.

The test results from Lakefield appeared to show that the regrinding of rougher concentrate would improve zinc concentrate grade and over-grinding (finer than 80% passing 65 µm) might cause a detrimental effect on zinc recovery.

However, PRA test results concluded that regrinding zinc rougher concentrate from 35% passing 74 µm to 99.6% passing 74 µm did not improve zinc concentrate quality.

Zinc Mineral Activation

Both test programs used copper sulphate (CuSO₄) as a zinc mineral activator in the zinc flotation circuit. Again, no test optimized the reagent dosage. The Lakefield tests used 700 g/t CuSO₄ (g/t of flotation feed) for all the tests. The PRA tests employed slightly lower dosages, ranging from 400 to 600 g/t CuSO₄. It concluded that the lower dosage did not cause a decrease in zinc recovery.

Flash Flotation

In 1996, PRA performed an exploratory test to investigate the metallurgical response of the BK/SK composite to flash flotation. The results obtained were encouraging; flash flotation produced a 65% lead concentrate recovering 26% of the silver and 14% of the lead.

Other Flotation Tests

The 1996 test program also conducted tests on the BK and SK composites separately using the flow sheet developed from the BK/SK composite. The BK composite responded well to the flow sheet. However, the concentrate grade from the SK composite was inferior compared to the BK composite.

The suppression of graphite was also tested in 1996. Carboxymethyl cellulose (CMC) was used to depress graphite carbon. It appears that the addition of CMC could not effectively reject the graphite carbon.

Bench Locked Cycle Tests

The 2007 test program conducted a locked cycle test to explore the effect of the circulation of middlings on metal recovery and concentrate quality. The test used the process conditions developed during the open cycle testing. The flow sheet is shown in Figure 16.3.

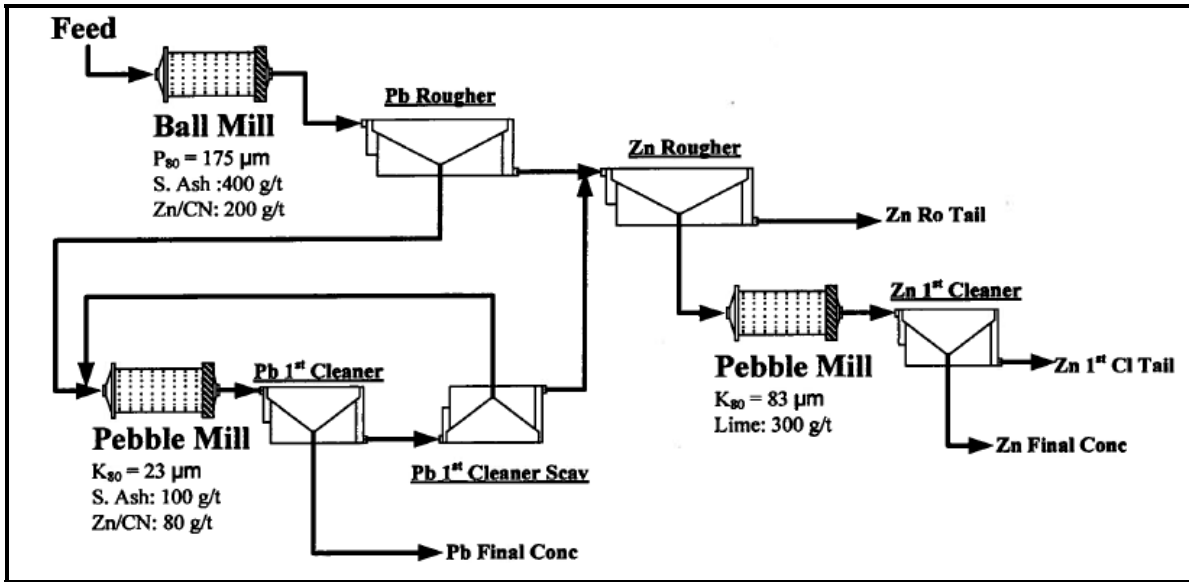

Figure 16.3: Locked Cycle Test Flowsheet - Lakefield

The test results, as summarized in Table 16.5, indicate that 97.6% of the lead was concentrated into a lead concentrate grading 72.5% Pb with 78.4% of the silver and 49.1% of the gold also reporting to the silver/lead concentrate. Zinc recovery was 71.7% at a grade of 56.0% Zn.

Table 16.5: Locked Cycle Test Results - Lakefield

Product	Weight (%)	Grade				Recovery (%)			
		Pb (%)	Zn (%)	Au (g/t)	Ag (g/t)	Pb	Zn	Au	Ag
Silver/Lead Concentrate	16.4	72.5	5.37	3.0	5864	97.6	7.6	49.1	78.4
Zinc Concentrate	14.9	0.45	56.0	1.2	750	0.6	71.7	18.2	9.1
Zinc Cleaner Tailings	5.6	0.87	38.8	0.95	1111	0.4	18.4	5.3	5.0
Zinc Rougher Tailings	62.9	0.24	0.44	0.433	142	1.3	2.4	27.2	7.3
Head	100	12.2	11.6	1.0	1227	100	100	100	100

The zinc loss to the zinc cleaner tailing was 18.4%. Zinc grade in the tailings was high, assaying at 38.8% Zn. This indicates that zinc cleaner flotation required additional reagents and scavenger flotation to improve metal recovery.

Two additional open cycle tests after the locked cycle tests confirmed that with further process optimization, metallurgical performance would improve, in particular, the recovery of the zinc minerals.

PRA performed a locked cycle test on the BK/SK composite to simulate potential metallurgical performance in industrial operation. The average results were obtained from the last three cycle tests and are presented in Table 16.6. Improved metallurgical performance was attained in the tests when compared to Lakefield’s test results, in particular for silver and zinc. A total of 95.3% lead was recovered to the lead concentrate along with 95.7% silver. Very little zinc reported to the silver/lead

concentrate and 94.3% zinc was recovered in the zinc concentrate. Lead and zinc concentrate grades were high, reaching 77.6% Pb in the lead concentrate and 52.1% Zn in the zinc concentrate.

Table 16.6: Locked Cycle Test Results (PRA)

Product	Weight (%)	Grade			Recovery		
		Pb (%)	Zn (%)	Ag (g/t)	Pb (%)	Zn (%)	Ag (%)
Silver/Lead Concentrate	15.6	77.6	0.88	6253	95.3	3.1	95.7
Zinc Concentrate	8.2	2.56	52.1	233	1.6	94.3	1.9
Zinc Rougher/Scavenger Tailings	76.2	0.51	0.16	33.0	3.0	2.7	2.5
Head	100.0	12.73	4.51	1022	100.0	100.0	100.0

16.1.6 Filtration and Thickening Test

PRA conducted settling tests on BK/SK flotation feed, silver/lead concentrate, and zinc concentrate; Percol 156 was used as a flocculent. The test results are given in Table 16.7.

Table 16.7: Settling Test Results

Sample	Percol 156 (g/t)	Unit Thickener Area (m ² /t/d)
BK/SK Comp (Fl. Feed)	0	0.09
	10	0.03
Silver/Lead Concentrate	0	0.09
	10	0.01
Zinc Concentrate	0	0.07
	10	0.01

Larox Inc. conducted pressure filtration tests on silver-lead and zinc concentrate; however, no report is available for review.

16.1.7 Further Test Work Recommendations

Further test work is recommended, including optimizing the reagent scheme, primary grind size and regrind size, and confirming a cyanide-free reagent scheme for lead/zinc separation. The test program should also include the investigation of the metallurgical responses of mineralization from various deposit zones to the developed flow sheet.

As well, the resistance to ball mill grinding should be confirmed.

16.2 Design Criteria

The design criteria used for this study are based on an average process rate of 408 t/d or 149,000 t/y. The key design criteria are shown in Table 16.8.

Table 16.8: Process Design Criteria

Description	Unit	Value	Source
Type Of Deposit	Silver/Lead/Zinc sulphide mineralization		
Ore Characteristics			
Specific Gravity	g/cm ³	3.46	6
Bulk Density	t/m ³	1.6	TBD
Moisture Content	%	5.0	1
Abrasion Index (Average)	g	0.046	6
Operating Schedule			
Crusher Plant			
Shift/Day		1	1
Hours/Shift	h	8	1
Hours/Day	h	8	1
Grinding and Flotation Plant			
Shift(s)/Day		2	1
Hours/Shift	h	12	1
Hours/Day	h	24	1
Days/Year	day	365	1
Plant Availability/Utilization			
Overall Plant Feed	t/a	149,000	3
Overall Plant Feed	t/d	408	1
Crusher Plant Availability	%	80.0	1
Grinding and Flotation Plant Availability	%	92.0	1
Crushing Process Rate	t/h	63.8	3
Grinding/Flotation Process Rate	t/h	18.5	3
Head Grades (LOM)	% Pb	11.60	1
	% Zn	9.60	1
	g/t Au	0.30	1
	g/t Ag	890	1
Recovery (LOM)	% Pb	95.6	6
	% Zn	94.0	6
Recovery (LOM) including in Pb & Zn concentrates	% Au	63.0	6
Recovery (LOM) including in Pb & Zn concentrates	% Ag	93.8	6
Silver-Lead Concentrate Grade (LOM)	% Pb	71.4	6
	% Zn	1.7	6
	g/t Au	1.0	6
	g/t Ag	4,442	6
Zinc Concentrate Grade (LOM)	% Pb	1.1	6
	% Zn	54.0	6
	g/t Au	0.4	6
	g/t Ag	390	6
Silver-Lead Concentrate Mass Recovery (LOM)	%	15.53	3
Silver-Lead Concentrate Production (LOM)	t/a	23,143	3
Zinc Concentrate Mass Recovery (LOM)	%	16.71	3
Zinc Concentrate Production (LOM)	t/a	24,900	3
Source Legend: 1 = Client, 2 = Industry, 3 = Calculation, 4 = Mass Balance 5 = Rescan, 6 = Test Reports, 7 = Suppliers 8 = Others			

16.3 Flowsheet Development

The process flowsheet design is based on the preliminary testwork results of PRA and Lakefield as well as information collected from a site visit that Wardrop conducted in March 2008.

The proposed process will employ conventional crushing, grinding, flotation, and dewatering processes.

Main valuable sulphides in the mill feed will be recovered by conventional differential flotation with a cyanide-free zinc suppressing regime. The flotation process will eliminate the potential environmental concerns of using cyanide in the process flow sheet. Silver and lead minerals will be recovered together to produce a silver-lead bulk concentrate and zinc minerals will be recovered to a separate zinc concentrate.

The final tailings from the zinc flotation circuit will be further floated to remove pyrite before being dewatered and backfilled in the underground mine or stored on the surface. The pyrite concentrate will be backfilled underground with the final tailings.

The process flow sheet will include the following main unit operations:

- A mobile crushing unit consisting of a jaw crusher, cone crusher, and screen;
- Primary grinding circuit;
- Silver-lead flotation and concentrate regrinding circuit;
- Zinc flotation circuit;
- Pyrite flotation unit;
- Concentrate dewatering circuit;
- Tailings dewatering and storage including paste backfill storage or dry stacking storage.

The simplified process flow sheet is presented in Figure 16.4.

16.4 Process Description

16.4.1 Crushing and Screening

ROM mill feed will be delivered by haul trucks from the mine sites and dumped directly into a mobile crushing unit or ROM stockpile. This crushing unit will consist of one jaw crusher, one cone crusher, and one vibrating screen in a closed circuit. The crushed material (-13 mm) will be conveyed to a fine mill feed storage bin with 500 tonnes live capacity. The crushed material from the fine mill feed bin will be withdrawn through a vibrating feeder onto a ball mill feed conveyor.

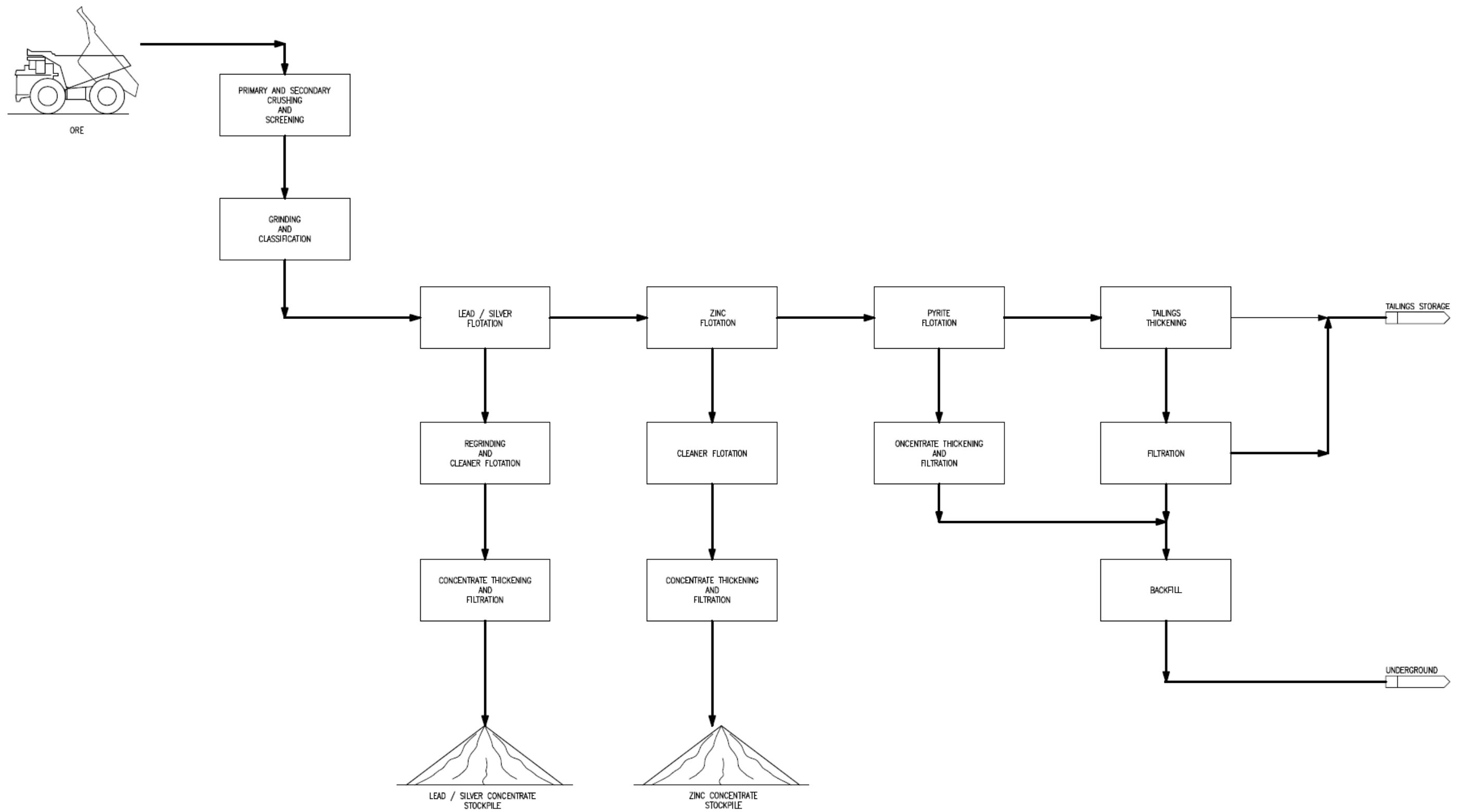

Figure 16.4 Simplified Flow Sheet

The crushing unit will be operated 8 hours per day at a process rate of 63.8 tonnes per hour.

The study recommends using a mobile crusher facility to crush ROM mill feed so that the crushing facility can be relocated to adjoining deposits.

16.4.2 Grinding Circuit

The crushed mill feed from the fine mill feed bin will be conveyed to the primary grinding circuit at a rate of 18.5 tonnes per hour. The circuit will consist of a ball mill and hydrocyclones in a closed circuit. The grinding mill is a ball mill, 2,134 mm in diameter and 2,743 mm long, with an installed power of 186 kW. The ball mill is currently available in the existing process plant at the Elsa Mill.

The mill discharge will be pumped to classification hydrocyclones. The underflow of the cyclones with 70% solids will return to the ball mill. The overflow, with a particle size of 80% passing 174 µm, will gravity-flow to flotation circuit.

Sodium sulphite and zinc sulphite will be added to the ball mill feed to suppress zinc minerals during lead mineral flotation.

16.4.3 Silver-Lead Flotation

Silver-Lead Rougher and Scavenger Flotation

The cyclone overflow from the primary grinding circuit will be further conditioned in an agitated tank with lime (to a pH of 8.5) and lead collectors (namely Aero 3418A and SIPX).

The conditioned slurry will flow by gravity to the silver-lead rougher/scavenger flotation circuit consisting of six 8-m³ flotation cells. Silver-lead rougher concentrate and scavenger concentrate will be pumped to the silver-lead regrind circuit. Silver-lead rougher scavenger tailings will be pumped to zinc flotation circuit.

Silver-Lead Rougher and Scavenger Concentrate Regrind

Silver-lead bulk rougher concentrate and scavenger concentrate will be reground in a 112 kW regrind ball mill operating in a closed circuit with two 150-mm cyclones. Cyclone overflow will flow by gravity to the first lead cleaner flotation cells. The regrinding prior to cleaner flotation will further liberate silver and lead minerals from gangues and other sulphide minerals to improve product quality and metal recovery. The target regrind particle size will be 80% passing 20 µm. The regrinding mill is currently available in the existing process plant at the Elsa Mill.

Zinc sulphate will be added to the circuit to improve the rejection of zinc minerals in subsequent upgrading processes.

Silver-Lead Cleaner Flotation

The rougher/scavenger concentrates will be upgraded in three stages of cleaner flotation. The first cleaner tailings will return to the silver-lead rougher flotation conditioning tank, while the second and third cleaner flotation tailings will recycle to the preceding cleaner stages.

The final silver-lead concentrate from the third lead cleaner flotation will be pumped to the lead concentrate thickener for dewatering.

The major equipment used in the lead flotation circuit will include the following:

- Six 8-m³ conventional flotation cells for rougher and scavenger flotation
- Three 3-m³ conventional flotation cells for first cleaner flotation
- Two 3-m³ conventional flotation cells for second and third cleaner flotation
- One 112-kW regrind ball mill.

16.4.4 Zinc Flotation

Zinc Rougher Flotation

Prior to zinc flotation, lead flotation tailings will be conditioned with copper sulphate to activate depressed zinc minerals, and lime to suppress pyrite. The flotation will generate a zinc rougher concentrate in four 8-m³ flotation cells and subsequently rougher scavengers concentrate in one same size cell. SIPX will be used as zinc mineral collector.

The scavenger concentrate will return to the zinc circuit head conditioning tank while the scavenger flotation tailings will feed to the pyrite flotation circuit.

Zinc Cleaner Flotation

The rougher flotation concentrate will be further upgraded by three stages of cleaner flotation in six 3-m³ conventional flotation cells. The first cleaner flotation tailings will be pumped back to the zinc circuit head conditioning tank. The second and third cleaner tailings will be recycled to the preceding cleaning stages. The third cleaner concentrate will be the final zinc concentrate, which will be dewatered prior to shipping.

Zinc flotation reagents will include lime, copper sulphite, SIPX, and DF250.

16.4.5 Pyrite Flotation

The current flow sheet conservatively assumes that a pyrite flotation circuit is incorporated in the flow sheet. Zinc flotation tailings will be conditioned with sulphuric acid, followed by pyrite flotation with SIPX. The pyrite concentrate will be stored underground by paste backfill together with a portion of the final tailings.

16.4.6 Concentrate Dewatering

Silver-Lead Concentrate Dewatering

The silver-lead concentrate will be pumped to a 3 m diameter high rate thickener. The underflow of the thickener will have a solid density of approximately 60%. A 23 m³ holding tank will hold the thickener underflow concentrate prior to dewatering to approximately 8% moisture by a pressure filter. The dewatered concentrate will discharge to the lead concentrate stockpile, which will have a storage capacity for 7 days of lead concentrate production.

Filtrate from the pressure filter will be pumped back to thickener feed well as dilution water. The concentrate thickener overflow will be distributed to the lead flotation circuit as process water.

Zinc Concentrate Dewatering

The zinc concentrate will be pumped to a 3 m diameter separate high rate thickener. The underflow of the thickener, with a solid density of 60%, will be further dewatered to approximately 8% moisture by a pressure filter. Prior to the filtration, a 23 m³ holding tank will retain the thickened concentrate in order to reduce potential interruption of filtration operation. The dewatered concentrate will be discharged onto the zinc concentrate stockpile, which will have a 7-day storage capacity.

16.4.7 Tailings and Pyrite Concentrate Dewatering and Handling

Final tailings will be thickened in a 5 m diameter high-rate thickener. Thickener underflow will be further dewatered by a 45 m² vacuum disc filter; filtrate will return to the tailings thickener feed well. Thickener overflow will be pumped to water polish pond, together with surface run-off water, mine water, and overflows from the two concentrate thickeners.

Pyrite concentrate will be dewatered by a 1 m thickener and stored in a holding tank prior to further dewatering by the 45 m² vacuum disc filter, which will be used for final tailings filtration.

The dewatered pyrite flotation concentrate and a portion of the dewatered tailings will be trucked to mine site and mixed with binder (cement) and water to generate backfill paste with approximately 77% solids. Variable speed positive displacement pumps will pump the paste to underground.

The rest of the dewatered tailings, with 10 to 12% moisture, will be transported by trucks to tailings storage sites.

The major equipment for tailings management includes:

- 5.0 m diameter tailings thickener;
- 1 m diameter pyrite concentrate thickener;
- 45 m² disc filter;
- Cement silo with dust collector;

- Twin screw paste mixer;
- Variable speed positive displacement paste pumps.

16.4.8 Reagent Handling and Storage

The collectors used in the process will include SIPX and 3418A. Sodium sulphite, zinc sulphate, lime, copper sulphate, and sulphuric acid will be used as regulators. D250 will be employed as frother for flotation. Flocculent will be added to thickeners to assist concentrates and tailings settlement.

All the reagents will be prepared in a separate reagent preparation and storage facility in a containment area. The reagent storage tanks will be equipped with level indicators and instrumentation to ensure that spills do not occur during normal operation. Appropriate ventilation and fire and safety protection will be provided at the facility.

All solid reagents such as copper sulphate, zinc sulphate, sodium sulphite, and SIPX will be dissolved, mixed, and diluted prior to being transferred into separate holding tanks from where the reagents will be distributed to various addition points.

Lime will be stored in a dedicated silo. It will be retrieved from the silo by a screw conveyor and mixed with water to produce 20% solid lime slurry. The slurry will be stored in a 3 m diameter by 3.5 m high agitated tank and distributed to addition points via a pressurized lime loop.

Liquid collectors and frother will be stored in separate holding tanks prior to being pumped in undiluted form to various addition points.

Anti-scale chemicals may be required to minimize scale build-up in the reclaim or recycle water lines. This reagent will be delivered in liquid form and metered directly into the reclaim water tank.

16.4.9 Instrumentation and Process Control

The plant control system will consist of a Distributed Control System (DCS) with PC-based Operator Interface Stations (OIS). The plant control rooms will be staffed by trained personnel 24 hours per day. The process control will be detailed in future studies.

16.4.10 General Plant Location

A general plant location map is shown in Figure 16.5.

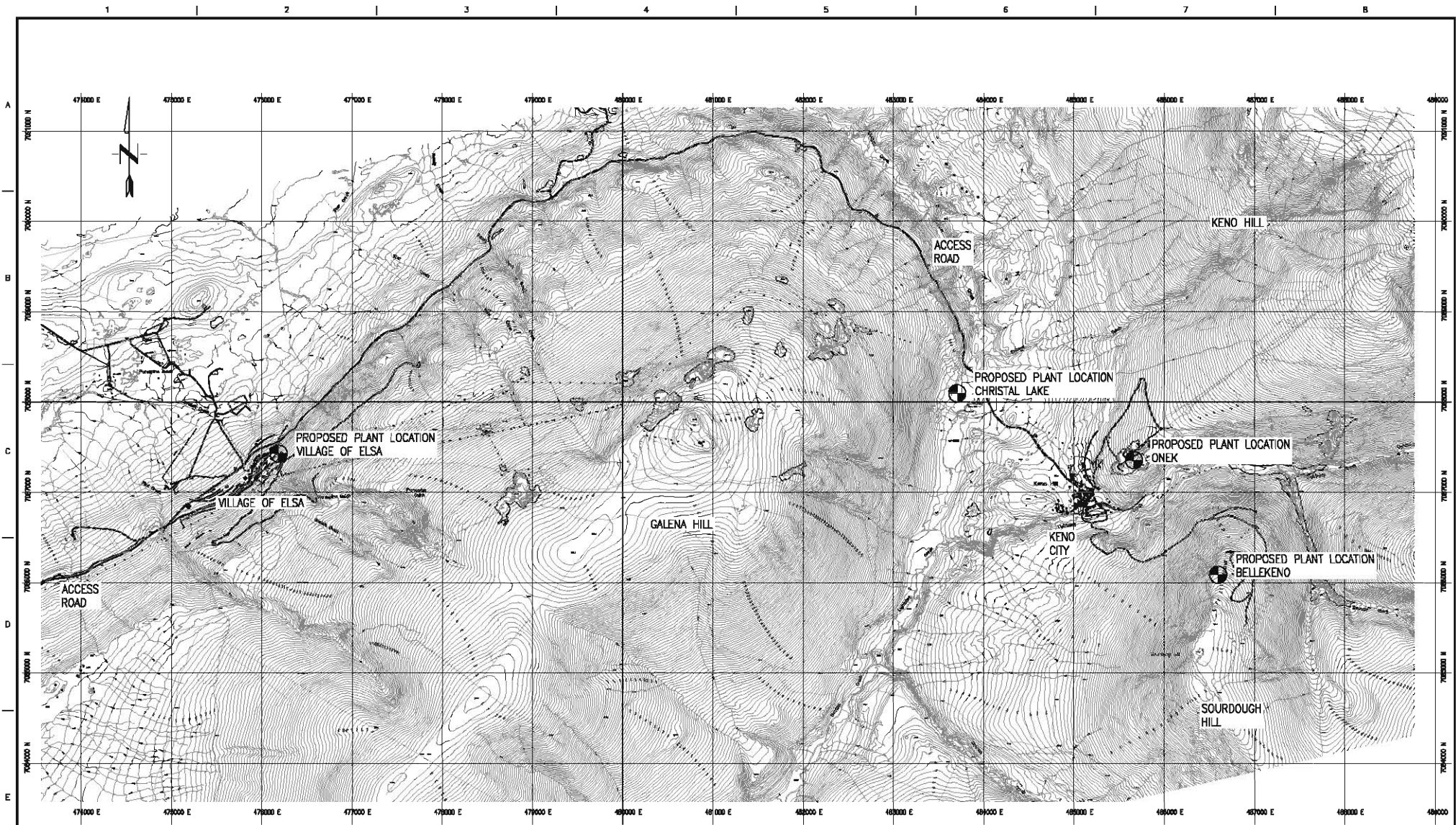

MILL SITE - PROPOSED LOCATIONS
PLAN

PROGRESS PRINT



THE INFORMATION CONTAINED ON THIS DRAWING HAS BEEN PROVIDED SOLELY FOR THE OWNER FOR USE ON THIS PROJECT AND IS NOT TO BE REPRODUCED, COPIED, OR TRANSMITTED IN ANY FORM OR BY ANY MEANS, ELECTRONIC OR MECHANICAL, INCLUDING PHOTOCOPYING, RECORDING, OR BY ANY INFORMATION STORAGE AND RETRIEVAL SYSTEM, WITHOUT THE WRITTEN PERMISSION OF ALEXCO. ANY REPRODUCTION OR TRANSMISSION OF THIS DRAWING IN WHOLE OR IN PART OTHER THAN FOR THE INTENDED PURPOSE IS AT THE SOLE RISK OF THE USER.			SECTION: LAYOUT SCALE: 1:20,000 DESIGN BY: HG DRAWN BY: AK CHECK BY:			YUKON TERRITORY 		TITLE: BELLEKENO PROJECT (SCOPING STUDY) MILL SITE PROPOSED LOCATIONS OVERALL ARRANGEMENT		
DWG. NO. REFERENCE DRAWINGS			DATE BY					FILENAME: A010001.DWG PROJECT NUMBER: 09539801.00 DRAWING NUMBER: A0-10-001 REV. A		
REV. NO. ISSUE No.			DESCRIPTION			DATE BY		REV. A		

ENVIRONMENTAL RESOURCE GROUP - 0365_000007.00 - BELLEKENO PROJECT (99-0855)-10-LEVEL/09/10-00-001.DWG

16.5 Process Options

The following four items have been investigated for the scoping study:

- Potential mill locations;
- Portable vs. permanent mill;
- Concentrate shipment options;
- Tailings handling (hydraulic tailings storage vs. dry stacking storage).

16.5.1 Potential Mill Locations

Wardrop conducted an investigation into potential mill locations. The following four options for potential mill locations were considered:

1. Existing Elsa Process Plant: The plant is located close to the town of Elsa and an existing tailings pond. After visiting the site, Wardrop concluded that only a minimal amount of equipment could be salvaged from the existing plant. This equipment includes two ball mills, seven OK flotation cells, and four diesel generators. The location would allow for some capital savings in infrastructure and operating savings in tailings disposal. Using the existing plant, however, will require long distance haulage of ROM mill feed from the mine to the plant since the existing plant is 13 km from the Bellekeno deposit. In addition, the plant building needs to be rebuilt.

2. Bellekeno Mine Site: This potential new plant location is situated <2 km south of the city of Keno. The location has the benefit of a short haulage distance for mill feed, however, it will require the development of new infrastructure and a new tailings storage site. The tailings may be stored by dry stacking but the location of the storage site still has to be identified.

3. Onek Mine Site: This potential new plant site is about 0.3 km north of the city of Keno. The major benefit of this location is a short ROM haulage distance between the mine and the process plant. However, the proposed new facility may be too close to Keno and the plant noise may disturb the city. Another disadvantage is the requirement of new infrastructure. Again, the option would require a new tailings storage site, which has not been identified but the current Onek pit offers a potential location for the storage of dry stacked tailings.

4. Chrystal Lake Site: This potential new plant location is approximately 1 km north-east of the city of Keno. The major benefit of this location is a short ROM haulage distance between site and the process plant, 3 km. The disadvantages of this location are the same as above – it will require new infrastructure and a new tailings storage site, which has not yet been identified.

Although there are existing infrastructure facilities at the Elsa process plant, Wardrop recommends option 2, the Bellekeno Mine Site, be used as the location of the new mill facility. This location has been selected based on a lower operating cost and because of its close proximity to the mining facilities.

16.5.2 Portable vs. Stationary Mill

Wardrop studied the construction of a portable mill in comparison to a stationary mill. A portable mill will require permitting for a new tailings disposal area and plant location. The benefit of having a portable mill would be the reduced operational costs due to a shortened ROM mill feed transport distance. Each time the portable mill is relocated it will require additional permitting and approval. This will have to be considered against the increased haulage distance for ROM material as potential future deposits are located further away from the stationary mill.

The stationary mill is the recommended option at this time but additional investigation should continue with the portable mill option.

16.5.3 Concentrate Shipment Options

The average annual concentrate production is estimated to be approximately 25,500 tonnes per year for the initial two years of operation and 48,500 tonnes per year, including 8% moisture, for the rest of the life of mine operation. The shipping cost of the concentrate will vary from year to year. The results of the study show that the cost of hauling and loading concentrate to a smelter in Trail, BC is estimated to be \$56.98 /t milled for the first two years of operation and \$60.43 /t milled for subsequent years.

Three potential destinations for concentrate shipment from Elsa were investigated:

Option 1: overseas smelters via Skagway;

Option 2: Trail, BC via Skagway and Seattle;

Option 3: Trail, BC via Fort Nelson.

The comparison study showed that Option 2 is the best option in terms of economics with an overall shipment cost (including loading and hauling) of \$60.43 /t milled or \$185.00 /t concentrate shipped. The overall operating cost for Options 1 and 3 are \$61.92 and \$66.99 /t milled, respectively. Accordingly, Option 2 is used as base case in the study.

16.5.4 Tailings Handling (Hydraulic Tails or Dry Stack)

There are three potential options for final tailings disposal:

Option 1: 100% of final flotation tailings to be stored in tailings ponds without dewatering.

Option 2: 100% of final flotation tailings to be dewatered and dry stacked.

Option 3: Approximately 50% of final flotation tailings are to be stored on surface by dry stacking and 50% (together with all pyrite concentrate) are to be stored underground as paste backfill.

Option 3 is recommended for the study in order to utilize pyrite concentrate and final flotation tailings as paste backfill, which provides support for the excavated underground and reduces surface environmental impact from the operations.

16.5.5 Mill Infrastructure

Mill Building

The majority of buildings at the existing Elsa Mill Site displayed signs of settlement and deformation with excessive wear due to weathering and, in some cases, collapse of structural components. These buildings are considered unsalvageable.

Four buildings identified on site to be salvaged are as follows:

- Thaw shed;
- Refining furnace building;
- Warehouse/truck shop; and
- Administration building.

The administration building is currently being used and requires no further upgrade for continued use. Upgrades and maintenance are required to bring the other buildings to up-to-date operational conditions. The warehouse/truck shop and administration building can be used with any of the mill location options but the thaw shed and refining furnace building are only suitable for the option of locating the potential mill at Elsa. New facilities are to be considered for other sites.

Plant Services

Air Supply and Distribution

Plant and instrument air will be provided from the plant air compressors and air blowers. The air service systems will supply air to the following areas:

Flotation: low pressure air for flotation cells will be provided by air blowers.

Filtering: high pressure air for filter pressing and drying of concentrate, provided by dedicated air compressors.

Crushing: high pressure air will be provided for required services in the crushing facility.

Instrumentation: instrument air will come from the plant air compressors and will be dried and stored in a dedicated air receiver.

17 Mineral Resource and Mineral Reserve Estimates

17.1 Introduction

In its initial exploration efforts on the Keno Hill project, Alexco has targeted the historical resources documented at the Bellekeno deposit by validating and confirming the existence of the polymetallic silver mineralization, particularly around the areas where previous operators have reported historical resources.

Alexco and SRK have audited the UHKM historical estimate for the Bellekeno Zones for the purposes of providing an interim resource estimate for the 99 Zone. The geological model for the Southwest and East Zones is complete allowing estimating mineral resources with confidence. The resource model for the Southwest and East Zones replace the previous November 10, 2007 estimates prepared by SRK. The 99 zone geological model is still under development and until completed the current resource statement for this zone has not changed.

17.2 Bellekeno Historical Resource Estimate

17.2.1 Historical Polygon Estimate Procedures

In March 1997, the remaining resources at Bellekeno Southwest, 99 and East Zones were published by UKHM mine staff. The estimate is based on underground diamond drill core, chip samples and percussion drilling samples. A manual polygonal method was used to estimate silver, lead, zinc and gold grades for each block.

Comprehensive UKHM procedures and standards for estimating resource blocks have not been located by Alexco in the mine archives. Ancillary data was used to determine the approximate methodology from the 11080-UKHM Elsa Mine Project Feasibility Study (Rescan, 1996) and various reports authored by D. Tenney in 1997.

Alexco understands that the polygonal estimates were based on using individual drill holes or face samples composited into a length and width weighted average grade for the face. Drill hole intersections or sampled faces were located in plan, longitudinal section, detailed stope and raise maps. Detailed geologic face maps were produced coincident with face sampling and plotted as a face record. Samples were sent to the lab, analyzed and recorded onto a daily assay sheet. Composites grades for each face were calculated using length weighted averages for the width of mineralization and a minimum width where the width of mineralization was limited. Minimum mining widths used by UHKM were:

- 1.5 m for shrink stopes;
- 2.1 m for square set and mechanized drift and fill stopes.

Final composites were plotted on longitudinal sections for the mine. The range of influence of each chip, drill hole or percussion hole samples was based on half the horizontal distance to next sample or geologic cut-off both in plan and section. The total block was calculated by summing up each composite in cubic metres and multiplying by density of 3.2 t/m³. Contained silver, lead and zinc were then divided by the total tonnes (tons) to derive the overall average grade for each metal.

17.2.2 Alexco Audit of Historical Resources

Alexco audited the UHKM polygon estimate by recalculating 38 polygon blocks for mining levels 600, 500 and 400 using only blocks historically classified as “probable” and “proven” by UKHM. These polygons represent approximately 14 percent of the total historic resource. Assay data used for this audit comprised principally of UHKM chip sample daily log sheets recovered by Alexco. Daily log sheet composites were checked by re-compositing intervals from original assay data contained in mine assay certificates where available. Chip sample locations on UHKM plans and long sections were also confirmed by locating sample location from survey points, timber sets and other points. Minimum compositing widths used by UKHM were also used by Alexco.

Polygon tonnages for each block were calculated by summing composite tonnages in or adjacent to the block. Composite tonnages were calculated by multiplying the following: the distance of mid-points to adjacent samples or block boundaries (area of influence), with composite length (width), and the vertical block height at the composite point.

Polygon grades were calculated using a tonnage weighting procedure. Metal grades for each composite were multiplied by the composite tonnage (as calculated above) and summed to arrive at a contained metal value for the entire polygon. The contained metal values for silver, lead and zinc were then divided by the total tonnage calculated for the polygon block resulting in averaged grades for each polygon block.

Tonnages for each zone were calculated by summing polygon tonnages. Block grades were calculated tonnage weighted average metal grades of polygon blocks.

In the course of the audit, Alexco found minor transcription, calculation and measurement errors in the UKHM polygonal tonnes and grade calculation that were corrected. Errors uncovered by Alexco are considered minor and not believed to affect the tonnage and grade estimates significantly. A comparison of historical to Alexco recalculated polygon tonnage and grade for three levels of the Bellekeno mine is shown in Table 17.1.

The audit establishes that while tonnage estimates are close, grade estimates vary from less than 1 percent to 25 percent with an average silver grade about 6 percent higher in the UHKM estimate and zinc grades significantly underestimated by UKHM by an average of 11 percent (Table 17.1). The differences in the two calculations may not be solely attributable to errors found by Alexco. Some differences may result from changes in the UKHM calculation procedures or assay data that has not been recovered by Alexco.

Table 17.1: Bellekeno Historical Resource Calculation Audit - Alexco Calculations Compared to UKHM Calculations

Level	Relative difference in calculation			
	Tonnage	Silver Grade	Lead Grade	Zinc Grade
548	0.00%	1.69%	12.65%	-25.38%
648	0.00%	16.62%	7.40%	-13.37%
748	0.00%	0.78%	-21.15%	4.28%
Average	0.00%	6.36%	-0.37%	-11.49%

Negative indicates Alexco recalculation is higher than UKHM calculation.

17.2.3 SRK Audit of Historical Resources

To validate Alexco audit findings, SRK chose to review and attempt to replicate calculations for 14 polygons re-calculated by Alexco. SRK used the same procedures and data used by Alexco. SRK found 20 calculations errors in a database that exceeds 1,500 checked calculations. Errors ranged from minor transcription errors, composite grade and composite width errors. Re-calculation of tonnages and grades suggest no significant change in tonnage and grade changes not exceeding 6 percent when compared to the Alexco audit.

The confidence level of the UHKM estimate is limited by the following factors:

- Bulk of estimate is based on chip sampling that may be biased because the sample is not a continuous volume of rock;
- Polygon estimates are prone to some level of error due to transcription errors, rounding, manual calculations and measurements;
- Percussion hole sampling often results in smearing of grade and represents a significant potential for biased sampling;
- Representation of a curvilinear vein as a linear vein or block may result in the overestimation of tonnages.

The possible bias of chip samples is reduced by limiting grade interpolation to distinct polygon blocks with horizontal ranges from 2 to 10 metres and vertical ranges up to from 20 to 50 metres. Errors inherent to manual polygon methods have been found but considered not to have a major effect on the calculation of tonnages and grades. Percussion data is likely to be unsuitable for polygon estimates and therefore should be excluded. In SRK’s experience, manual errors can have a partial cancelling effect on deposit scale. Similarly differences in the Alexco and UHKM estimates while significant at level to level basis, average lower over three levels and presumably would follow the same trend over the entire deposit. This contention is supported by Alexco and SRK not finding systematic errors in auditing the polygon estimate.

SRK has established that a portion of historical resources for the Bellekeno 99 Zone meet the CIM definition guidelines and therefore can be reclassified as mineral resources. The basis of this conversion is that:

- Two audits of the UKHM polygon estimate for the Bellekeno 99 Zone;
- The silver polymetallic mineralization exhibits good geological continuity;
- There is a high density of sampling for the UKHM historical resource blocks classified as “probable” and “proven”.

However, in converting the historical resource blocks, any blocks estimated using percussion drilling samples and those not classified as “probable” or “proven” were omitted. Historical polygon blocks located in the upper three levels of the 99 Zone have also been excluded because accessibility may be problematic due to extensive mining by UKHM in the area. The historical resource estimates for the 99 Zone can be reclassified as an Inferred Mineral Resources under the CIM Definition Standards for Mineral Resources and Mineral Reserves (December 2005). The mineral resource statement for the 99 Zone is presented in Table 17.2.

Table 17.2: Mineral Resource Statement* for the Bellekeno 99 Zone, SRK Consulting, November 10, 2007

Category	Zone	Tonnage [tonnes]	Ag [g/t]	Pb [%]	Zn [%]	Au [g/t]
Inferred (SI)	99	55,700	1,593	11.1	5.5	0.0

* Reported at a cut-off of 514 g/t silver. Mineral resources are not mineral reserves and do not have demonstrated economic viability. All figures have been rounded to reflect the relative accuracy of the estimates. Audited by Alexco and SRK and converted to the metric system using conventional conversion factors. Silver grade capped at 3.43 kg/t .

17.3 Bellekeno Southwest and East Zone Resource Estimates

For the Bellekeno Southwest and East Zones, Alexco completed sufficient drilling to interpret with confidence the geology of the silver-lead-zinc polymetallic mineralization and there is sufficient new reliable assaying data to support re-estimating the mineral resources using a geostatistical approach constrained by wireframes. The sections below summarize the resource models constructed by SRK.

As an aid to modelling, all Bellekeno data was rotated to align the general strike of the deposit along an east-west axis. Datamine rotation parameters are:

- Rotation about Z-axis: -52.5 degrees;
- Translation Coordinates: X = 486,600, Y = 7,086,150, Z = 0.0 in both unrotated and rotated coordinate systems.

17.3.1 Specific Gravity Measurements

Alexco systematically measures core specific gravity for all drill core. Specific gravity is measured using a balance and measuring the weight of core pieces in air and in water. Core weighted in water is not covered by wax or plastic film. Core volume is determined by measuring the length of each core sample and multiplying by core diameter. Specific gravity measurements are taken systematically over entire drilled interval and are not restricted to mineralized areas. Some

mineralized intervals consist of friable “galena sands” that cannot be measured. Alexco has taken 312 core specific gravity measurements during the 2006 and 2007 drilling programs at Bellekeno.

The specific gravity database also contains 297 determinations made by ALS-Chemex on pulverized assay samples by pycnometry. Pulp specific gravity measurements were made by ALS-Chemex using assay pulps from Alexco drill core within the Bellekeno Southwest and East Zones. No pulp specific gravities were taken by UKHM.

17.3.2 Data

The drill hole databases used in the preparation of the updated Southwest Zone interpretation included thirty-one diamond core drill holes, 147 chip samples and forty-three percussion holes, details are listed in Table 17.3. Changes from the previous estimate reflect additional drilling by Alexco and modifications of the previous interpretation.

Table 17.3: Summary of Database Used For Modelling the Bellekeno Southwest Zone

Sample Type	Number of Boreholes	Number of Samples
Percussion	43	191
Chips	147	429
Historical Core	17	62
Alexco Core	11	128

The preparation of the East Zone interpretation included 28 diamond core drill holes, and 105 chip samples. No percussion holes were drilled in the east zone. Details for the east zone are listed in Table 17.4. The database included assays for silver, gold, lead and zinc for all Alexco holes. UKHM diamond and percussion holes contained silver, lead and zinc assays but not all intervals were assayed for gold. UKHM chip samples were assayed silver, lead and zinc only.

Table 17.4: Summary of Database Used for Modelling the Bellekeno East Zone

Sample Type	Number of Boreholes	Number of Samples
Chips	105	152
Historical Core	9	29
Alexco Core	19	87

Geological data in the drill hole databases used in the interpretation of zone contacts consisted of vein mineralogy data for Alexco holes only. Limited and vein geology data was available for UKHM holes diamond holes. No geological data was available for percussion and chip samples.

The databases contained core recovery data for Alexco diamond drill holes and UKHM diamond drill holes. Recovery data is not relevant for chip and percussion holes. Alexco recovery data was based on drilling runs with an average run length of 3-metres. Recovery was not measured for each sampled interval. Recovery is calculated by core recovered over run length. The basis of UKHM recovery data could not be established from historical data. In the database all recoveries are expressed as a percentage.

17.3.3 Geological Interpretation

Alexco provided SRK with a geological interpretation of the Southwest and East Zones of the Bellekeno vein. The Southwest Zone mineralization is bounded on top by the lower contact of the Schist unit and at the bottom by the upper contact of the Greenstone unit (Figure 17.2). The East Zone is bounded to the northeast by a fault and by topography. Alexco has also interpreted a high grade shoot for the East Zone. These elements of the East Zone are shown in Figure 17.3.

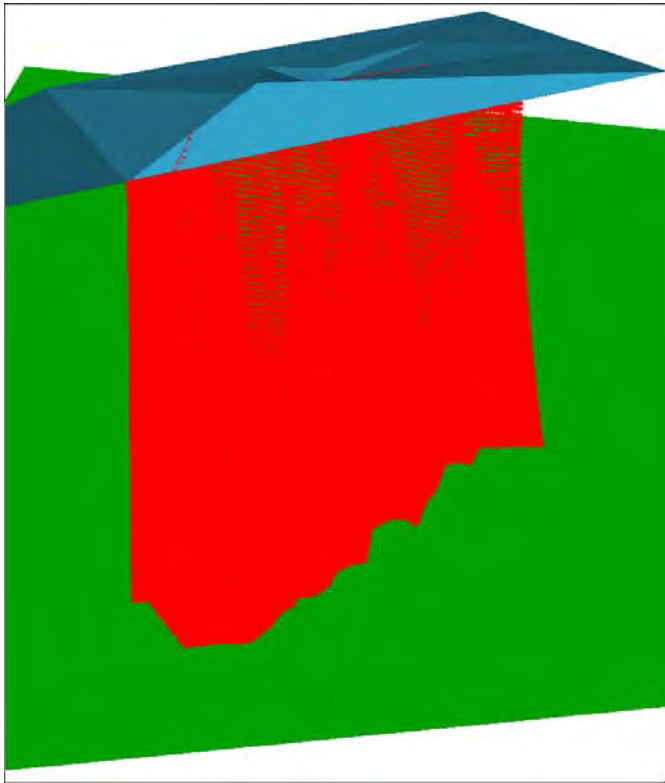

Figure 17.1: Southwest Zone Geological Boundaries Looking Northwest. Schist Unit Lower Contact (blue), Greenstone Unit Upper Contact (green), Bellekeno Southwest Zone Model (red)

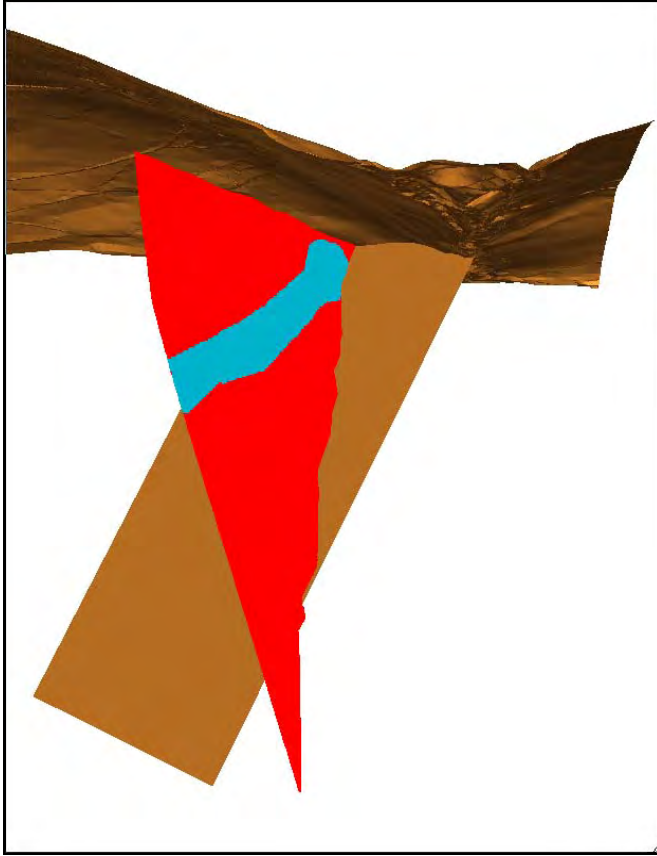

Figure 17.2: East Zone Geological Boundaries Looking Northwest. Northeast Bounding Fault (brown), Bellekeno East Model (red) and High Grade Shoot (light blue)

The Alexco interpretations consisted of sectional outlines of each of the zones spaced at approximately 10-metre intervals. The interpretation was restricted to the main Bellekeno vein and did not include any stringer mineralization in the footwall, vein splays, and veins sub-parallel to the Bellekeno vein as data spacing was not sufficient to define these features. The interpretation was based on UHKM and Alexco drill holes, chip samples and percussion holes. UKHM chip sample data was converted to drill hole data by Alexco. Good geological data was available for Alexco holes but limited geological information was available for UKHM diamond and percussion holes. No geological data was available for chip samples.

As the Alexco interpretation was not snapped to drill holes, SRK modified the Alexco outlines by snapping sectional strings to drill hole data and in some cases adding additional sectional strings. SRK sectional strings were then wireframed using Datamine to create a three dimensional solid representing the Southwest and East Zones of the Bellekeno vein.

For both of the zones SRK inferred vein footwall and hanging wall contacts for the Alexco drill holes on the basis of a combination of geological and assay criteria noted below:

- Appearance of siderite in mineralogy data;

- Sharp increases in zinc grades;
- Significant silver and lead grades;
- Alexco gross metal value variable greater than US\$20.

The gross metal value is calculated by multiplying metal grades by assumed metal prices. Metal price assumptions are US\$10 troy ounce silver, US\$600 troy ounce gold, US\$1.32 kg (US\$0.60 pound) lead, and US\$2.2 kg (US\$1.00 pound) zinc.

The resolution of interpreted sections was not sufficient to capture chip sample contacts spaced at small intervals from 1 to 3 metres. In these areas, chip sample contacts were approximated over distances of 5 to 10 metres.

Percussion holes, drilled only in the Southwest zone, were found to have limited utility in defining geological boundaries. Some percussion hole collars were located outside of existing underground development and therefore considered not valid. A comparison of correctly located percussion holes with diamond drill hole and chip sampling data indicates a substantial smearing of percussion metal grades beyond vein boundaries determined by diamond drilling.

17.3.4 Drill Hole Database

SRK considered the percussion drill hole samples not suitable for metal grade analysis or resource estimation because this type of drilling is always associated with some degree of sample contamination from drill hole walls and other sources. Although UKHM appears to have taken measures to minimize this contamination SRK considers these samples biased. As noted above, percussion holes often smeared the grades beyond the confines of the vein mineralization.

Using the SRK drill hole intervals that intersected the wireframe solid for the Southwest Zone two drill hole databases for each of the two zones were generated. One data set was comprised of chip sample data and drill core data and a second data set comprised of drill hole data only (including both Alexco and UHKM holes).

Blank grade intervals, primarily in the UKHM drill core data were represent missing or un-assayed intervals. Some of these intervals were not assayed because of the absence of silver mineralization. As the reason for absent assays is difficult to determine, SRK chose to take a conservative approach in assigning blank assay low metal grades as below:

- Silver: 1.00 g/t;
- Gold: 0.02 g/t;
- Lead: 10.00 ppm;
- Zinc: 30.00 ppm;

Assays results for all Alexco diamond drill holes were received by SRK.

Core recovery data for diamond drill holes were reported as percentages in the drill hole database. Alexco core recovery was measured on a run length basis. Core recovery for each sample interval was not determined by Alexco. UKHM core recovery data is largely complete. SRK set all undefined core recovery values and those exceeding 100 percent to a value of 100. All core recovery values less than 0 % were set to 0.

17.3.5 Specific Gravity Data

The Bellekeno Southwest Zone has very significant specific gravity changes that can occur over small distances (less than 5 metres). The primary source of this variation is the presence of galena mineralization than can be localized to massive veins over 1 metre long. Core specific gravity measurements range from 2.56 to 7.07 (Table 17.5). In deposits of this nature, it is important to model specific gravity changes within these ranges. Measuring core specific gravities can have limited utility in this deposit because highly mineralized sections of the zone may be comprised of highly broken or friable sections of massive galena that cannot be used in core measurements. As an alternative, specific gravity of sample pulps can be readily analysed for assayed intervals. Pulp specific gravity cannot replace core specific gravity measurements because they do not account for voids, fractures or vugs in core. However, as a measure of density variations these specific gravity measurements are useful.

Table 17.5: Statistics for Core Specific Gravity Measurements Southwest and East Zones

STATISTICS	Southwest Zone	East Zone
TOTAL NUMBER OF RECORDS		
NUMBER OF SAMPLES	29	25
NUMBER OF MISSING VALUES	0	0
NUMBER OF VALUES > TRACE	29	25
MAXIMUM	7.07	5.59
MINIMUM	2.7	1.31
RANGE	4.37	4.28
TOTAL	124.76	90.7
MEAN	4.3021	3.65
VARIANCE	1.476	0.7683
STANDARD DEVIATION	1.215	0.8765
STANDARD ERROR	0.2256	0.1753
COEFFICIENT OF VARIATION	0.28	0.24
SKEWNESS	0.7571	-3.97E-02
KURTOSIS	-0.6642	0.9415
GEOMETRIC MEAN	4.1451	3.5058
SUM OF LOGS	41.236	31.3607
MEAN OF LOGS	1.4219	1.2544
LOGARITHMIC VARIANCE	0.072	0.0773
LOG ESTIMATE OF MEAN	4.297	3.6439

*Blank values assigned 100%, values above 100 set to 100%

The existing pulp specific gravity data is insufficient to factor grades or give an indication of possible variations of specific gravity for the deposit. Using a regression analysis of metal grades versus pulp specific gravity SRK found that a reasonable correlation between silver and lead grades with pulp specific gravity. Lead grades were slightly better correlated than silver grades, with correlation coefficients of 0.92 compared to 0.86. Because of the higher correlation the linear regression formula for lead and pulp specific gravity was used to estimate pulp specific gravity for intervals without this measurement. The regression plot is presented in Figure 17.3. The regression formula used to estimate pulp specific gravities (“PSG”) is:

$$PSG=0.000004*PB+3.312095, \text{ where PB is interval lead grade.}$$

The regression estimate was capped at the upper and lower limits of correlation at 6.8 and 2.7 respectively.

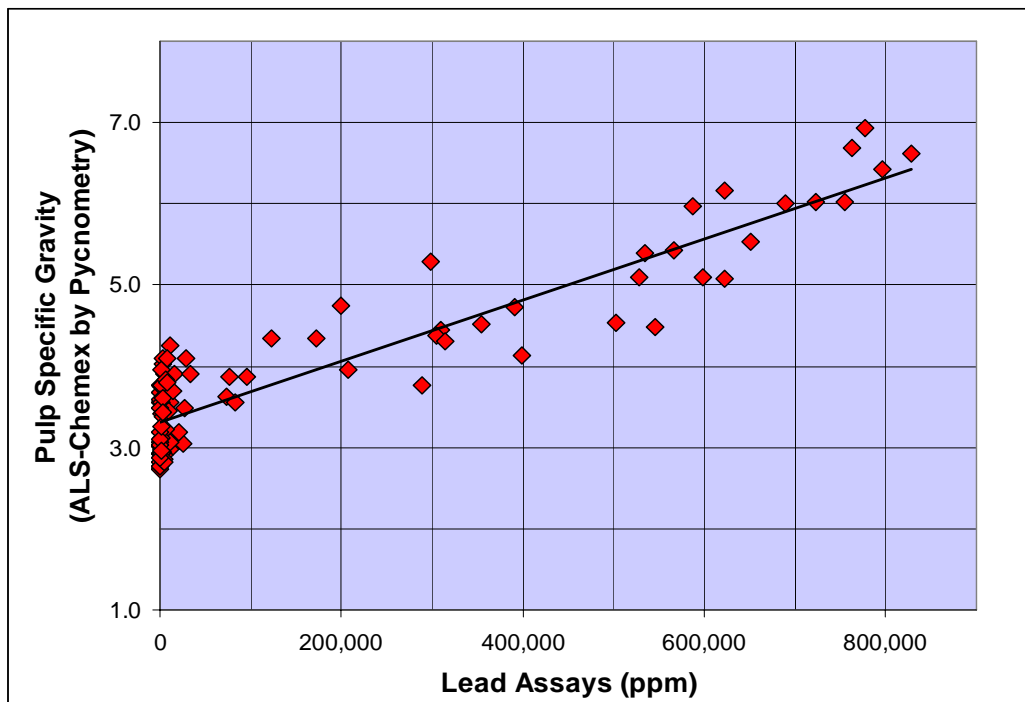

Figure 17.3: Linear Regression between Lead Grades and Pulp Specific Gravity Southwest Zone

The East Zone is characterized by a smaller range in specific gravity and slightly lower variability than the Southwest Zone. Core specific gravity measurements range from 5.59 to 1.31, and pulp specific gravities range from 4.12 to 2.66. Similar to the Southwest Zone, it is important to consider modelling specific gravity for resource estimation. Limited data for both core and pulp specific gravity measurements, 14% and 56% of assayed intervals respectively, do not allow composite weighting or estimation of specific gravity. Correlation analysis of pulp and specific gravity and silver or lead grade show correlation coefficients of less than 0.45. This poor correlation does not allow the calculation of pulp specific gravities using linear regression. SRK believes the lack of a

good correlation between grade and specific gravity may be related East Zone mineralization being different from the Southwest zone. Because of limited data and poor correlation of variables, density weighting of composites and estimates of block grades are not feasible for the East Zone model.

17.3.6 Statistical Analysis and Compositing

Metal assay statistics for the Southwest Zone chip with drill core and drill core only are presented in Table 17.6 and Table 17.7. These data sets represent data that has been processed according to the previous section. That is blank assay values have been replaced with low values, missing recovery numbers have been set to 100%, values less than zero have been set to 0% and values above 100% have been set to 100%. Statistics indicate a highly skewed distribution for gold and silver that is typical of precious metal deposits. Lead and zinc follow a similar grade distribution. A high dispersion of grades is quite evident in both data sets with a particularly high dispersion of silver grades occurring in the chip plus core sample data set. Silver assay means range from approximately 916 g/t in the chip plus core data set and to a lower value of 731 g/t in the core only data set. In either case, this indicates a relatively high grade distribution of silver assays. Gold assays are relatively low with means ranging from 0.2 g/t to 0.5 g/t. Average lead grades are approximately 10% in data sets with and without chip samples. Zinc grades range from five and six percent in the combined and core only data sets.

Core recovery for the Southwest zone averages at about 86% with a minimum of 0% recovery. As core recovery was measured by run lengths these estimates are considered conservative.

Metal assay statistics for the East Zone chip with drill core and drill core only are presented in Table 17.8 and Table 17.9. These data sets represent data that has been processed according to the previous section. That is, blank assay values have been replaced with low values, missing recovery numbers have been replaced or set to lower and upper bounds. Statistics indicate a highly skewed distribution for gold and silver that is typical of precious metal deposits. Lead and zinc follow a similar grade distribution. A high dispersion of grades is quite evident in both data sets with a particularly high dispersion of silver grades occurring in the chip plus core sample data set. Silver assay means range from approximately 337 g/t in the chip plus core data set and to a slightly higher value of 353 g/t in the core only data set. In either case, silver grades are significantly lower than the southwest zone. Gold assays are relatively low with means ranging from about 0.2 g/t to 0.3 g/t. Average lead grades are similar about 2% and significantly lower than Southwest Zone averages. Zinc grades are generally higher than the East Zone, and vary from about seven to nine percent for the two data sets.

Core recovery for the Southwest zone averages at about 83% with a minimum of 24% recovery. As core recovery was measured by run lengths, these estimates are considered conservative.

Table 17.6: Summary Statistics for Southwest Zone Chip and Core Samples.

STATISTIC	Ag [g/t]	Au [g/t]	Pb [ppm]	Zn [ppm]
TOTAL NUMBER OF RECORDS				
NUMBER OF SAMPLES	764	764	764	764
NUMBER OF MISSING VALUES	0	0	0	0
NUMBER OF VALUES > TRACE	764	764	764	764
MAXIMUM	12041.28	8.32	828300.00	416000.00
MINIMUM	0.03	0.00	1.00	30.00
RANGE	12041.25	8.32	8.2830E+05	4.1597E+05
TOTAL	700411.75	176.14	7.7198E+07	3.4292E+07
MEAN	916.77	0.23	101044.55	44884.37
VARIANCE	2.7570E+06	0.52	4.0140E+10	5.3480E+09
STANDARD DEVIATION	1660.00	0.72	200300.00	73130.00
STANDARD ERROR	60.07	0.03	7248.00	2646.00
COEFFICIENT OF VARIATION	1.81	3.12	1.98	1.63
SKEWNESS	2.53	7.23	2.15	2.73
KURTOSIS	7.69	68.63	3.44	8.00
GEOMETRIC MEAN	98.63	0.01	6277.70	11067.12
SUM OF LOGS	3507.81	-3226.03	6681.00	7114.16
MEAN OF LOGS	4.59	-4.22	8.74	9.31
LOGARITHMIC VARIANCE	7.22	5.06	8.48	4.31
LOG ESTIMATE OF MEAN	3651.21	0.18	436300.24	95714.85

*Blank values assigned 100%, values above 100 set to 100%

Table 17.7: Summary Statistics for Southwest Zone Core Samples

STATISTIC	Ag [g/t]	Au [g/t]	Pb [ppm]	Zn [ppm]	PSG	Recovery [%]
NUMBER OF SAMPLES	334	334	334	334	170	334
NUMBER OF MISSING VALUES	0	0	0.00	0	164	0
NUMBER OF VALUES > TRACE	334	334	334	334	170	332
MAXIMUM	7770.00	8.32	828300.00	404100.00	6.93	100.00
MINIMUM	0.03	0.01	1.00	30.00	2.73	0.00
RANGE	7769.97	8.32	8.2830E+05	4.0407E+05	4.20	100.00
TOTAL	244456.51	174.83	3.2046E+07	1.8877E+07	680.09	28732.92
MEAN	731.91	0.52	95946.91	56517.16	4.00	86.03
VARIANCE	1.9210E+06	1.03	4.3260E+10	8.1830E+09	1.20	387.80
STANDARD DEVIATION	1386.00	1.01	2.0800E+05	9.0460E+04	1.10	19.69
STANDARD ERROR	75.85	0.06	11380.00	4950.00	0.08	1.08
COEFFICIENT OF VARIATION	1.89	1.94	2.17	1.60	0.27	0.23
SKEWNESS	2.23	5.01	2.25	2.16	1.12	-2.05
KURTOSIS	4.97	31.99	3.74	4.05	0.38	4.12
GEOMETRIC MEAN	36.95	0.11	2590.68	9274.19	3.87	83.21
SUM OF LOGS	1205.57	-730.00	2625.13	3051.09	230.03	1467.88
MEAN OF LOGS	3.61	-2.19	7.86	9.14	1.35	4.42
LOGARITHMIC VARIANCE	9.72	4.18	11.12	6.51	0.06	0.11
LOG ESTIMATE OF MEAN	4768.69	0.91	672751.64	239946.08	3.99	87.86

Table 17.8: Summary Statistics for East Zone Chip and Core Samples

STATISTICS	Ag [g/t]	Au [g/t]	Pb [ppm]	Zn [ppm]
NUMBER OF SAMPLES	329	329	329	329
NUMBER OF MISSING VALUES	0	0	0	0
NUMBER OF VALUES > TRACE	329	329	329	329
MAXIMUM	4265.68	4.28	425000.00	522000.00
MINIMUM	0.25	0.00	8.00	27.00
RANGE	4265.43	4.28	4.2499E+05	5.2197E+05
TOTAL	1.1094E+05	52.12	6.4033E+06	2.1958E+07
MEAN	337.21	0.16	19463.02	66742.43
VARIANCE	5.4570E+05	0.20	3.6080E+09	1.2260E+10
STANDARD DEVIATION	738.70	0.44	6.0060E+04	1.1070E+05
STANDARD ERROR	40.73	0.02	3311.00	6103.00
COEFFICIENT OF VARIATION	2.19	2.81	3.09	1.66
SKEWNESS	3.10	4.80	4.40	2.00
KURTOSIS	10.16	29.82	19.82	3.22
GEOMETRIC MEAN	36.90	0.01	1350.25	11092.15
SUM OF LOGS	1187.13	-1391.74	2371.45	3064.30
MEAN OF LOGS	3.61	-4.23	7.21	9.31
LOGARITHMIC VARIANCE	5.62	4.14	5.42	4.98
LOG ESTIMATE OF MEAN	613.21	0.12	20324.09	133937.51

*Absent values replaced with nominal low grade values. **Blank values assigned 100%, values above 100 set to 100%.

Table 17.9: Summary Statistics for East Zone Core Samples

STATISTICS	Ag [g/t]	Au [g/t]	Pb [ppm]	Zn [ppm]	PSG	Recovery [%]
NUMBER OF SAMPLES	177	177	177	177	98	177
NUMBER OF MISSING VALUES	0	0	0	0	79	0
NUMBER OF VALUES > TRACE	177	177	177	177	98	177
MAXIMUM	4083.25	4.28	329600.00	522000.00	4.12	100.00
MINIMUM	0.25	0.01	8.00	27.00	2.66	24.00
RANGE	4083.00	4.28	3.2959E+05	5.2197E+05	1.46	76.00
TOTAL	62610.87	51.67	3.8697E+06	1.5259E+07	336.71	14680.06
MEAN	353.73	0.29	21862.90	86210.50	3.44	82.94
VARIANCE	5.2220E+05	0.33	3.8570E+09	1.6950E+10	0.16	308.30
STANDARD DEVIATION	722.60	0.57	6.2110E+04	1.3020E+05	0.41	17.56
STANDARD ERROR	54.32	0.04	4668.00	9786.00	0.04	1.32
COEFFICIENT OF VARIATION	2.04	1.96	2.84	1.51	0.12	0.21
SKEWNESS	2.70	3.47	4.02	1.61	-0.34	-1.35
KURTOSIS	7.36	15.48	16.00	1.43	-1.15	1.30
GEOMETRIC MEAN	26.29	0.06	1167.31	11741.08	3.41	80.41
SUM OF LOGS	578.68	-508.75	1250.05	1658.64	120.25	776.52
MEAN OF LOGS	3.27	-2.87	7.06	9.37	1.23	4.39
LOGARITHMIC VARIANCE	7.40	3.71	6.94	6.51	0.01	0.07
LOG ESTIMATE OF MEAN	1063.77	0.36	37500.45	304142.24	3.44	83.46

Statistical analysis and geostatistical analysis of grade distributions require that the sample data sets have common support. This is often undertaken by compositing drill holes to a common interval length. The underlying premise is that each composited interval represents approximately an assay from a similar and continuous volume of samples. For core samples, common support is straight forward. Although core size for this project ranges from HQ to NQ and BQ for the historical boreholes, this difference is not considered to be significant in particular with the large drill spacing. Chip samples do not represent a continuous volume of sample and therefore may not provide common support when compared to drill core samples. Chip sampling can also be biased because by nature, this sampling technique will have a tendency to sample preferentially soft or loose rock relative to hard wall rock. Problems with chip sample bias has been extensively documented and researched.

As a test of this contention SRK has used quantile-quantile (“Q-Q”) plots to compare grade distributions of chip and core samples for both Southwest and East zones, these plots are presented in Figure 17.4 and Figure 17.5. Southwest zone Q-Q plots for silver indicate a significant over estimation of chip silver grades ranging up to 1000 g/t. Similarly, significant overestimating of lead grades by chip sampling is indicated up to approximately 1,000,000ppm. Interestingly, the zinc Q-Q plot shows a fairly similar grade distribution for chip and core samples with a slight underestimation of chip zinc grades compared to core grades around 100,000 ppm.

East Zone Q-Q plots for silver indicate a significant under estimation of chip silver grades ranging from 100 g/t to 1,000 g/t with similar grades above 1,000 g/t silver. Lead grades show an underestimation of chip samples up to about 1,000 ppm, trending to similar grades from 1,000 ppm to 4,000 ppm and a general under estimation for grades greater than 4,000 ppm. Similarly, significant overestimating of lead grades by chip sampling is indicated up to approximately 10,000 ppm and underestimation above 10,000 ppm. Zinc chip samples appear to be over estimated up to approximately 5,000 ppm and underestimated above 5,000 ppm.

Potential bias of chip samples metal grades are inherent in the sampling technique and is indicated by Q-Q plots for silver, lead and zinc grades. Consequently the chip sample for both Southwest and East Zone data sets are considered not appropriate for grade estimation.

SRK considers that full intersection width is the most appropriate method for compositing both Southwest and East zones as:

- Vein widths range from 1 to 10 metres with an average of about 5 metres;
- Some of the mineralized vein material is very friable and may cause support problems if selective mining within the vein is used;
- Variability of mineralization assemblages is much smaller than the current data resolution of the vein mineralization.

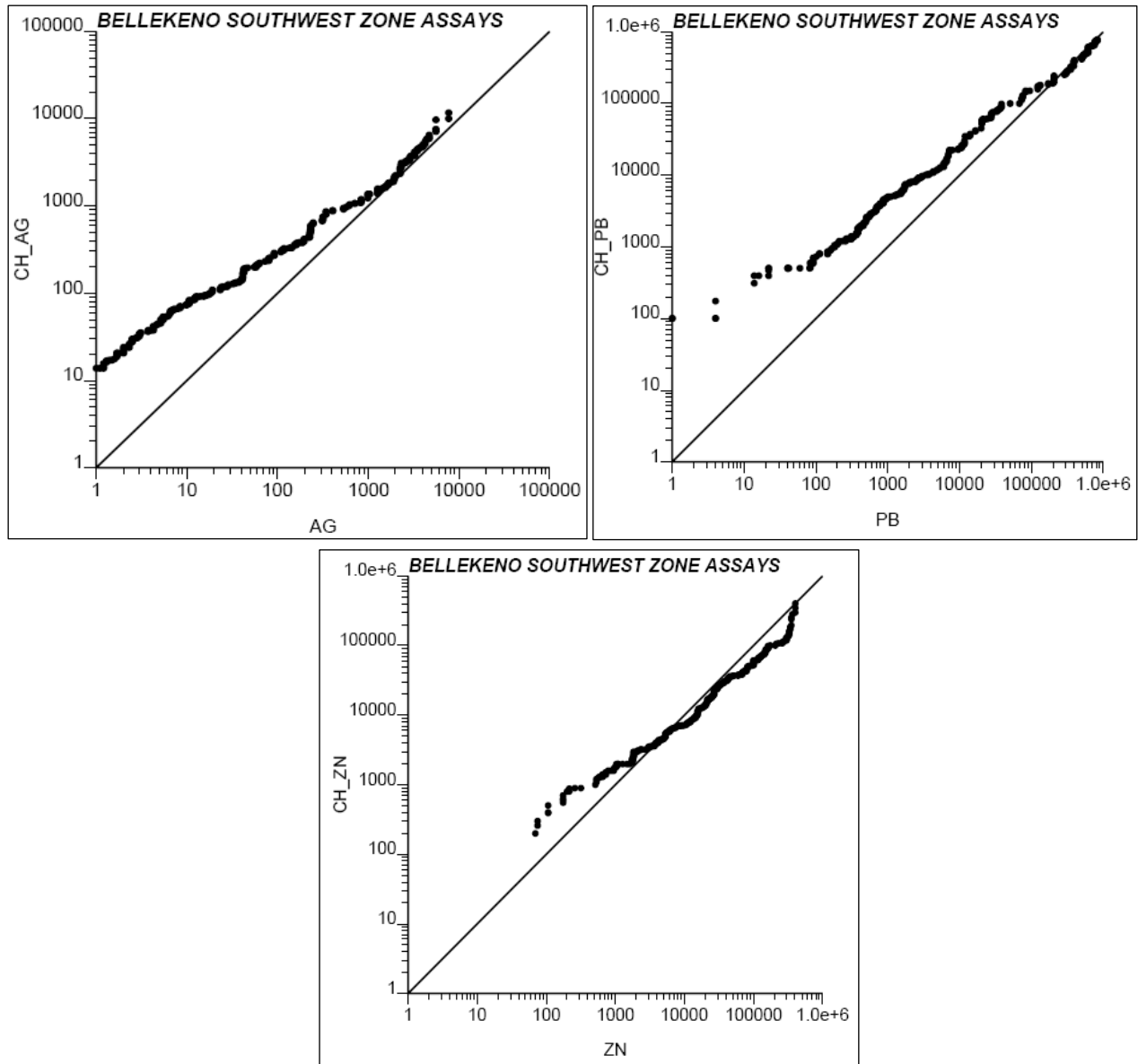

**Figure 17.4: Q-Q Plots Comparing Chip and Core Samples for the Southwest Zone.
Top Left: Silver Grade, Top Right: Lead Grade, Bottom: Zinc Grade**

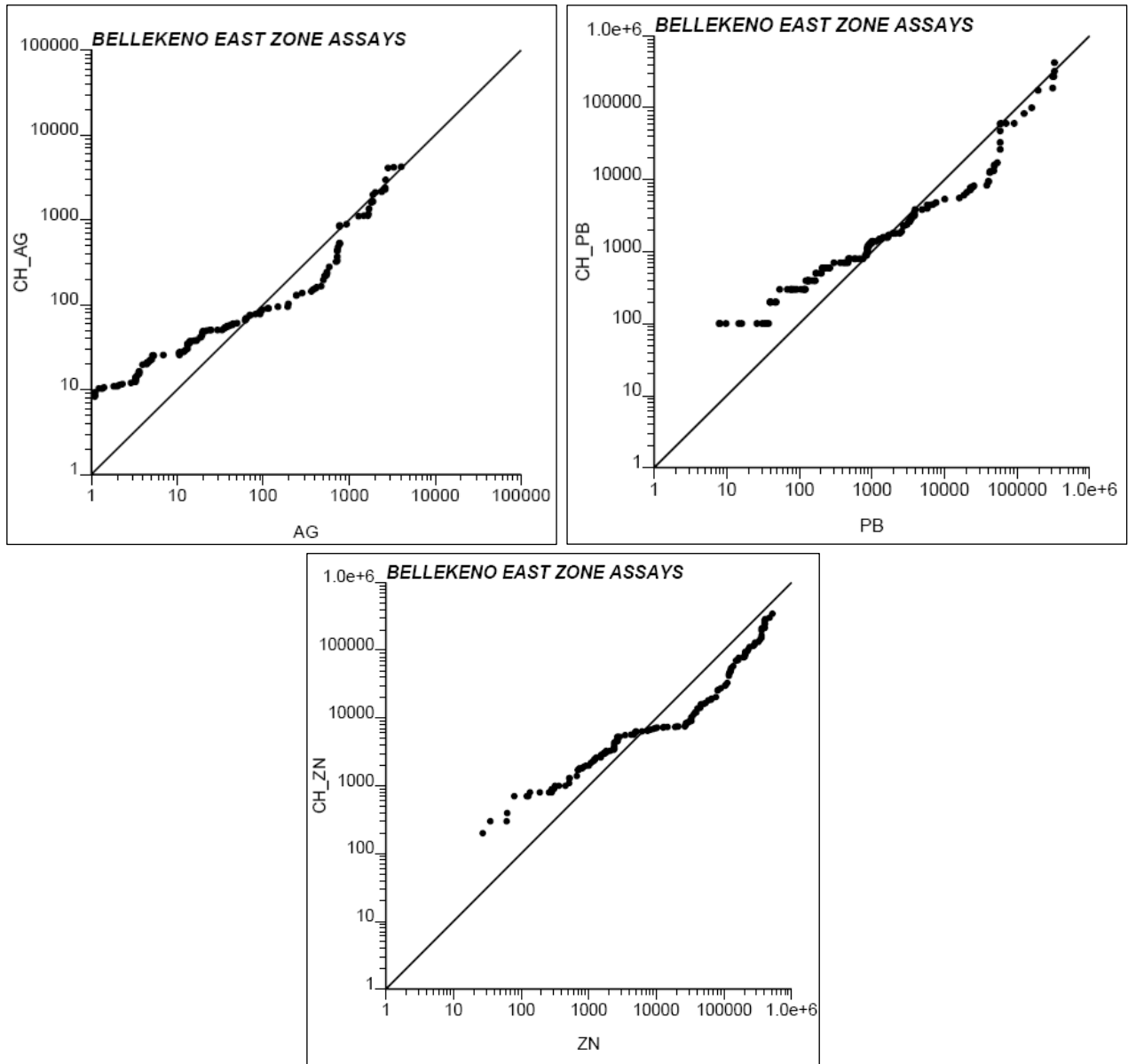

Figure 17.5: Top. Q-Q plots Comparing Chip and Core Samples East Zone. Top Left: Silver Grade, Top Right: Lead Grade, Bottom: Zinc Grade

In the compositing the Southwest zone, each interval was weighted by core recovery, length of sample and pulp specific gravity. Core recovery weighting resulted in sample grades being reduced by the core recovery value for each drill run, where missing core was assumed to be at zero metal grades. This weighting produced a negative weighting on intervals with missing core. Length weighting adjusts for the different length of samples in each composite. Pulp specific gravity weighting result in intervals with higher specific gravity values being assigned a higher grade weighting factor for the particular interval when composite grades are calculated. A separate composite file was created for calculating pulp specific gravity values. These composites were

weighted by interval length only. These values for pulp specific gravity were added to the composite after the compositing of metal grades. Full intersection width composites statistics for the Southwest Zone drill core is presented in Table 17.10.

East Zone composites were restricted to weighting of core intervals by sample length and core recovery only as specific gravity weighing was not possible because of limited data values. Core recovery weighting resulted in sample grades being reduced by the core recovery value for each drill run, where missing core was assumed to be at zero metal grades. Full intersection width composites statistics for the East Zone drill core is presented in Table 17.11.

Table 17.10: Summary Statistics for the Southwest Zone Drill Core Composites

STATISTIC	Ag [g/t]	Au [g/t]	Pb [ppm]	Zn [ppm]
NUMBER OF SAMPLES	31	31	31	31
NUMBER OF MISSING VALUES	0	0	0	0
NUMBER OF VALUES > TRACE	31	31	31	31
MAXIMUM	3350.92	1.09	457989.87	155960.88
MINIMUM	0.24	0.00	6.97	26.00
RANGE	3350.68	1.08	457982.90	155934.88
TOTAL	14140.46	8.58	758069.29	75784.80
MEAN	456.14	0.28	56711.91	34702.74
VARIANCE	560100	0.09	1271000000	1670000000
STANDARD DEVIATION	748.40	0.30	112800.00	40860.00
STANDARD ERROR	134.40	0.05	20250.00	7339.00
COEFFICIENT OF VARIATION	1.64	1.07	1.99	1.18
SKEWNESS	2.33	1.12	2.35	1.60
KURTOSIS	5.39	0.37	4.49	2.29
GEOMETRIC MEAN	52.60	0.10	2833.12	7860.04
SUM OF LOGS	122.84	-70.96	246.42	278.06
MEAN OF LOGS	3.96	-2.29	7.95	8.97
LOGARITHMIC VARIANCE	7.75	3.16	11.12	6.49
LOG ESTIMATE OF MEAN	2535.83	0.49	734858.62	202008.27

Table 17.11: Summary statistics for the East Zone Drill Core Composites

STATISTICS	Ag [g/t]	Au [g/t]	Pb [ppm]	Zn [ppm]
NUMBER OF SAMPLES	28	28	28	28
NUMBER OF MISSING VALUES	0	0	0	0
NUMBER OF VALUES > TRACE	28	28	28	28
MAXIMUM	1281.88	1.08	67131.23	295682.04
MINIMUM	0.23	0.00	9.02	58.08
RANGE	1281.65	1.07	6.7122E+04	2.9562E+05
TOTAL	4510.95	5.45	2.2543E+05	1.1957E+06
MEAN	161.11	0.19	8.0511E+03	42702.20
VARIANCE	7.8930E+04	0.09	2.2840E+08	5.8170E+09
STANDARD DEVIATION	280.90	0.31	15110.00	76270.00
STANDARD ERROR	53.09	0.06	2856.00	14410.00
COEFFICIENT OF VARIATION	1.74	1.57	1.88	1.79
SKEWNESS	2.51	1.81	2.45	2.43
KURTOSIS	6.65	2.21	6.00	5.04
GEOMETRIC MEAN	17.21	0.04	940.75	6320.46
SUM OF LOGS	79.68	-88.94	191.71	245.04
MEAN OF LOGS	2.85	-3.18	6.85	8.75
LOGARITHMIC VARIANCE	6.90	3.74	5.85	5.53
LOG ESTIMATE OF MEAN	542.17	0.27	17500.06	100186.20

17.3.7 Grade Capping

Southwest zone compositing has significantly reduced the variability of grade distributions for Southwest Zone metal assays. However, variability remains relatively high for lead at a coefficient of variation (“COV”) of 1.99 for lead. Cumulative probability plots of silver and lead grade distributions for the drill composites are presented in Figure 17.6. These plots do not indicate a strong high grade trend sub-domain for silver grades but lead composites showing a weak but not well defined trend high grade trend. An examination of the spatial distribution of high grade silver and lead values in composited and non-composited drill hole plots within the Southwest Zone shows that the highest silver grades in the data sets define a high grade zone that is essentially defined by four Alexco drill holes:

- K-06-0011;
- K-07-0090;
- K-07-0101;
- K-07-0106.

These four drill holes occur adjacent to each other defining a high grade domain or mineralized shoot. High grade silver values for these drill holes are associated with high grade lead values and to a lesser extent elevated zinc and gold values. Based on this information, SRK does not consider these high grade values as outliers. As such capping is not considered appropriate to the Southwest

Zone composite data set. This contention is supported by the historical capping of silver at approximately 3,428 g/t (100 troy oz/short ton). Gold and zinc grade variability is considered low enough not to require capping.

Compositing for the East Zone data set has also significantly reduced the variability of metal grade distributions. Grade variability for composites is generally slightly higher than the Southwest data set. Cumulative probability plots of silver and lead grade distributions composites are presented in Figures 17.6 and 17.7. These plots indicate a weak but significant high grade trend defined by three silver composites above the 90th percentile. Similarly, a weak but significant high grade lead trend is defined roughly above the 90th percentile. An examination of the spatial distribution of high grade silver and zinc values shows that all high grade intersections occur within a high grade shoot defined by Alexco. Similar to the Southwest zone, silver and lead grades correlate well with the higher grade results. Zinc grades show a weaker correlation. SRK concludes that high grade intercepts are not statistical outliers but are spatially distinct and define a high grade shoot or domain.

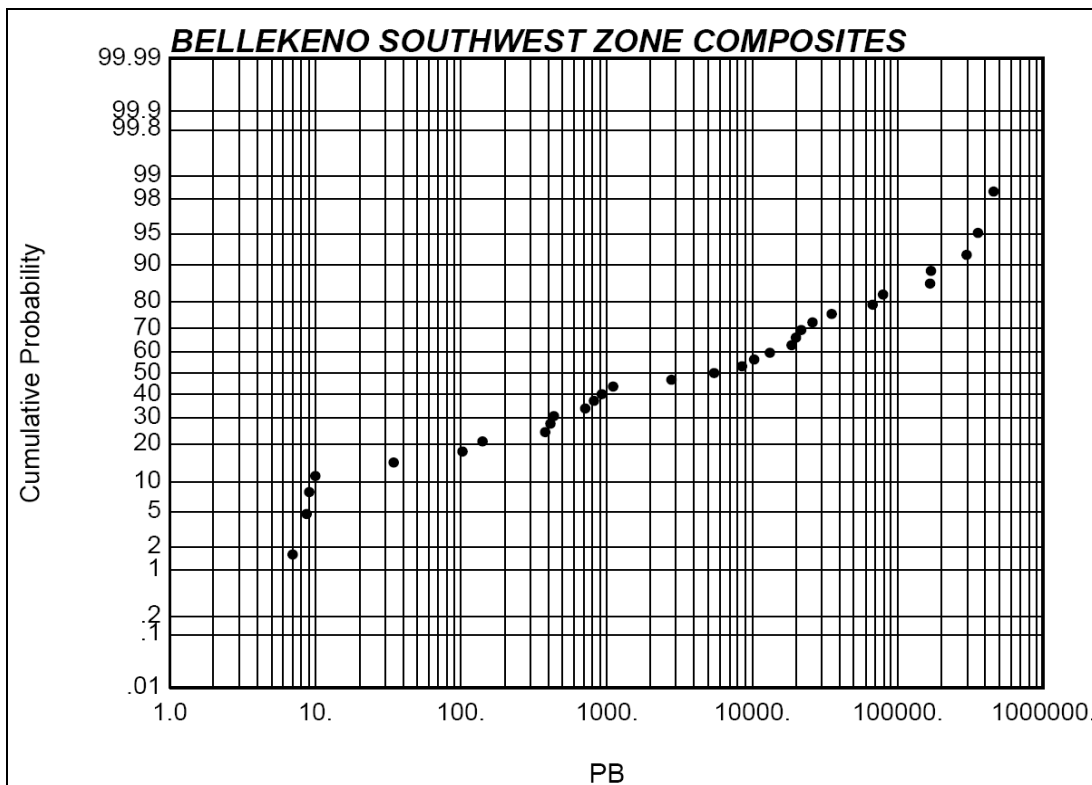
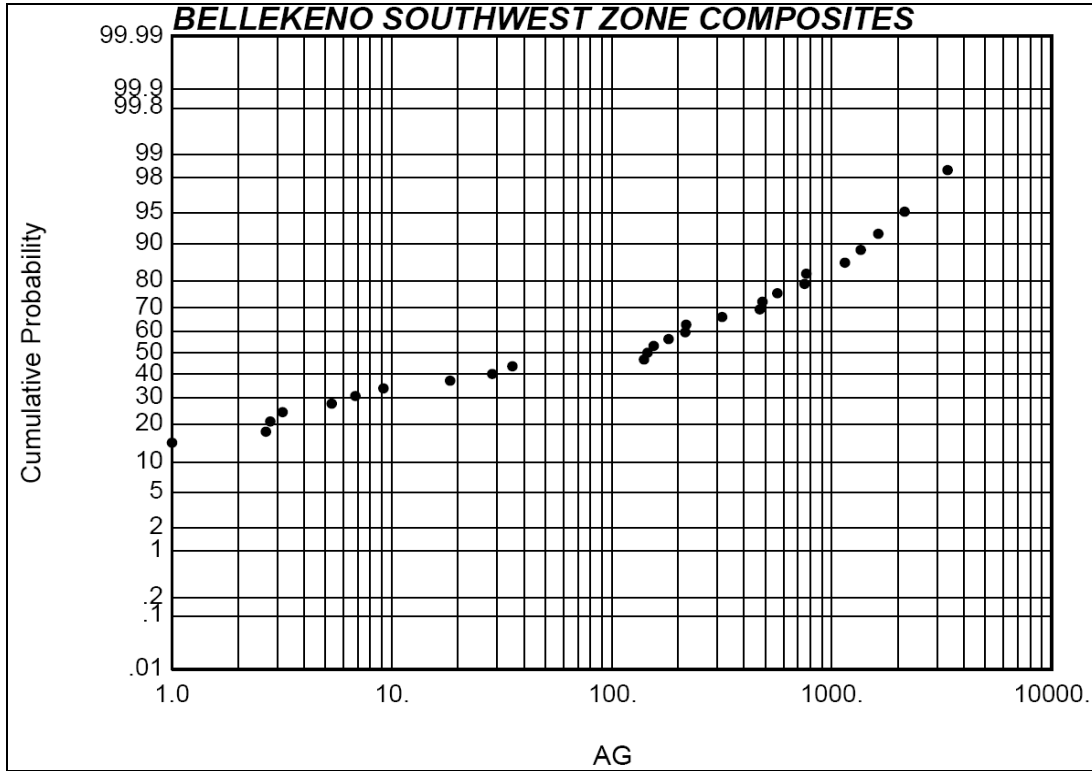

Figure 17.6: Cumulative Probability Plots for Southwest Zone Drill Core Composite Samples

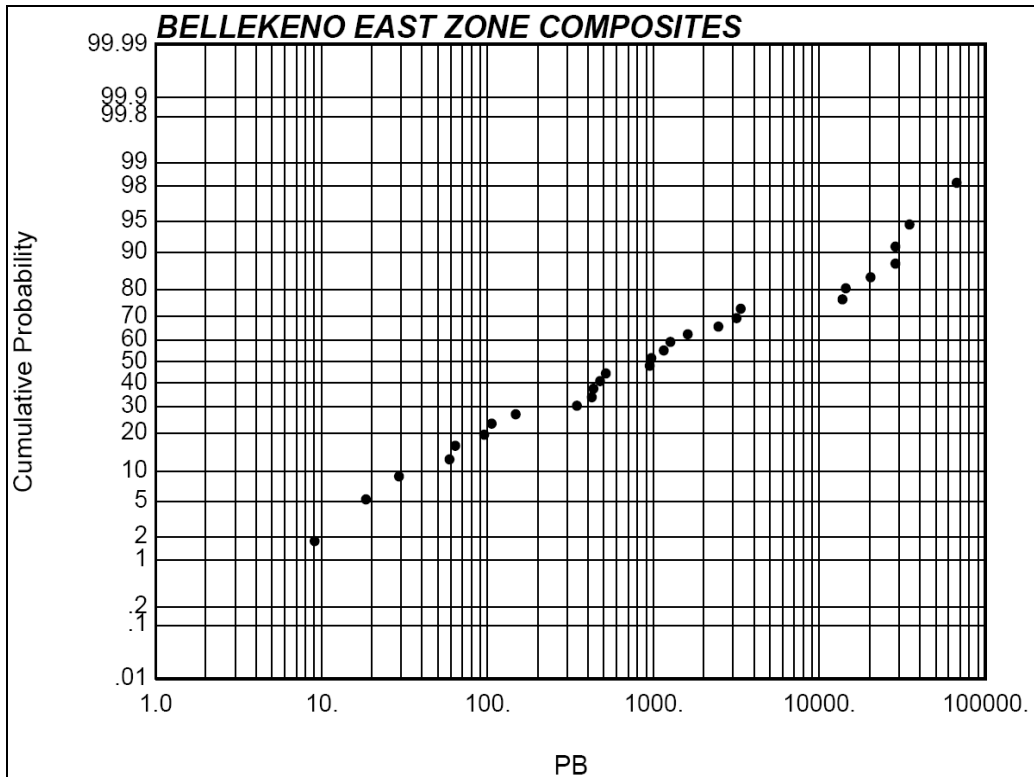
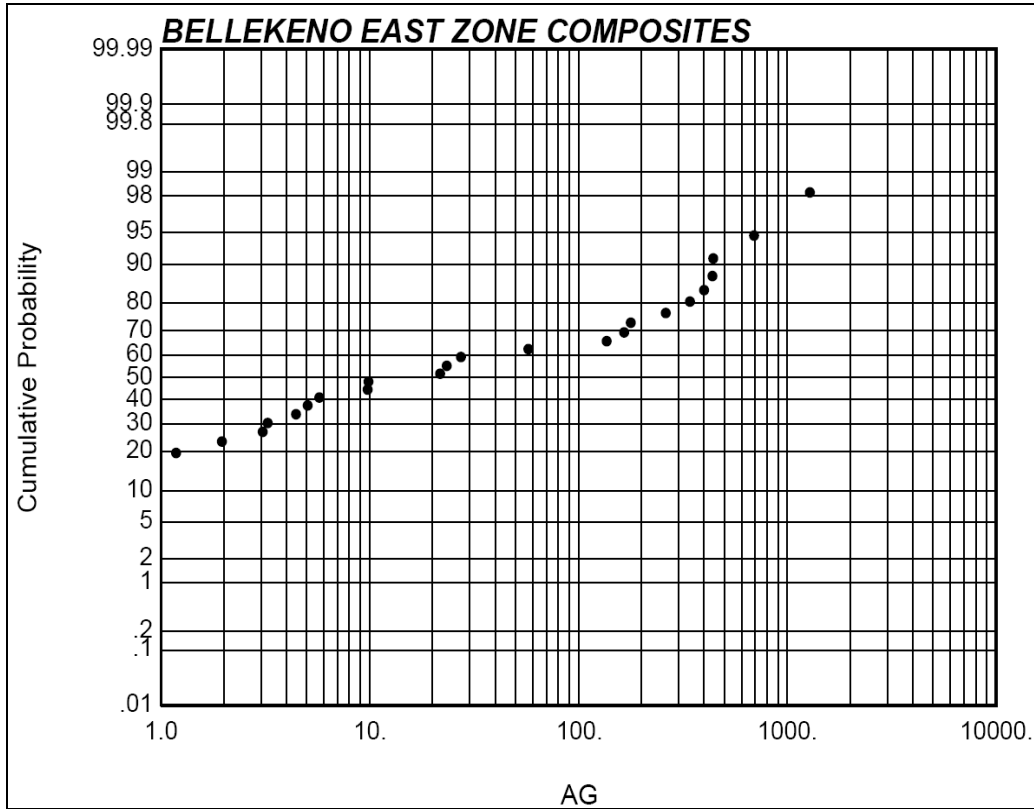

Figure 17.7: Cumulative Probability Plots for East Zone Drill Core Composite Samples

17.3.8 Variography

Composited drill data provides only 31 data points for the Southwest Zone and 28 data points for the East Zone, both are insufficient for generating usable variograms for each zone. SRK next considered using a combination of chip and drill core composites with a total of 175 composites for the Southwest zone and 124 composites for the East Zone. SRK was unable to define any readable variograms using these data sets separately. SRK next used a combined data set of all available drill hole and chip sample composites (full intersection composited) for the entire Bellekeno vein including Zones 99, East and Southwest with better variogram results. Data sets for the 99 Zone were limited to composites within a preliminary outline of the contiguous Bellekeno vein.

With the combined set of composites, SRK was able to develop variogram models using pair-wise relative variograms. Variography indicated spatial continuity oriented sub-parallel to the general strike of 085° and dip of 70° and a plunge of 20° using rotated coordinates. Datamine rotation parameters for the variogram are given in Table 17.12.

Variography for this data set was weakly sensitive to plunge directions. Strike and dip-direction variography did not show any significant difference in spatial continuity. Continuity in the perpendicular or “thickness” direction was poorly defined in some variography and therefore the range in this direction was assumed to be 15 metres.

Table 17.12: Datamine Variogram Orientation

Rotation Axis	Rotation Angle [°]
Z Axis	-5
X Axis	-75
Y Axis	-20

Gold variography did not provide any readable variograms. Single structure silver variograms for the strike dip direction are presented in Figure 17.10. Lead variograms consisted of two structure spherical variograms, first structure ranges of 9 and 15 metres were not considered as these ranges were significantly less than the average diamond drill hole spacing for the Southwest and East Zones. Zinc variograms also consisted of two structure spherical models with first structure ranges of 6 metres (strike direction) and 22 metres (dip-direction). In the former case the range was considered two small in comparison to average composite spacing and in the later case the first structure was considered near enough to the primary range that that an extra estimation range in one direction would not make a significant difference in the resource estimate. Lead and zinc variogram models are presented in Appendix B. Variogram ranges determined from variography are summarized in Table 17.13.

Variogram parameters were checked against possible bias that may be introduced by using 99 zone data. Variograms were determined independently using only chip and core data from the Southwest and East zones. This check resulted in single structure spherical variogram models that confirmed

the above variogram ranges. Additionally, variography indicated a better sensitivity to a plunge of 20°. Variograms used in this check are presented in Appendix B.

Table 17.13: Variogram Ranges

Metal	Variogram Direction Ranges [m]		
	Strike	Dip Direction	Normal
Silver	30	30	15
Lead	30	30	15
Zinc	35	35	15

17.3.9 Block Model

Two separate block models were developed based on the wireframe solid for the Southwest and East Zones. Block model parameters are given in Table 17.14. The block model size was based primarily on likely smallest mining unit for the deposit and a block sized that models the vein dimensions in a reasonable manner. The block model was developed with three levels of sub-blocks to ensure that the volume of the vein volume is accurately represented. All models were terminated by topography were applicable.

Table 17.14: Characteristic of the Bellekeno Block Models.

Type	X Direction	Y Direction	Z Direction
Origin	486,200	7,085,400	0
Block Size [m]	5	3	5
Number of Blocks	280	333	280

Alexco provided SRK with wireframes of underground development and stoped out areas for the Southwest and East Zones. SRK modified these wireframes into wireframe solids representing mined out areas for each of the zones. These wireframe solids were then used to remove mined out areas from the respective block model.

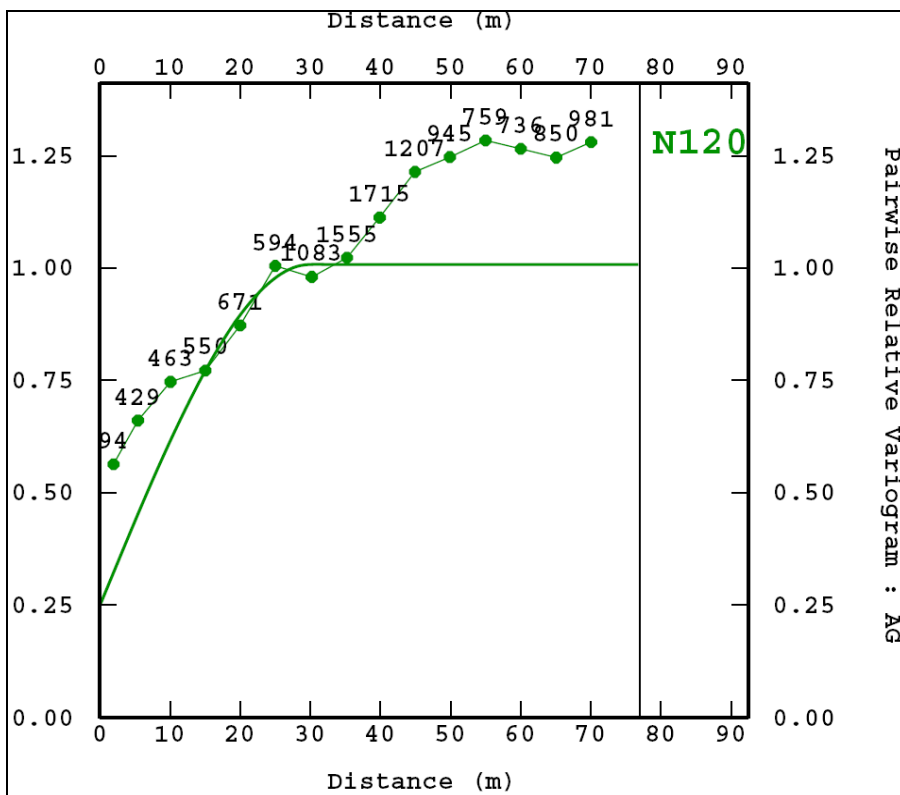
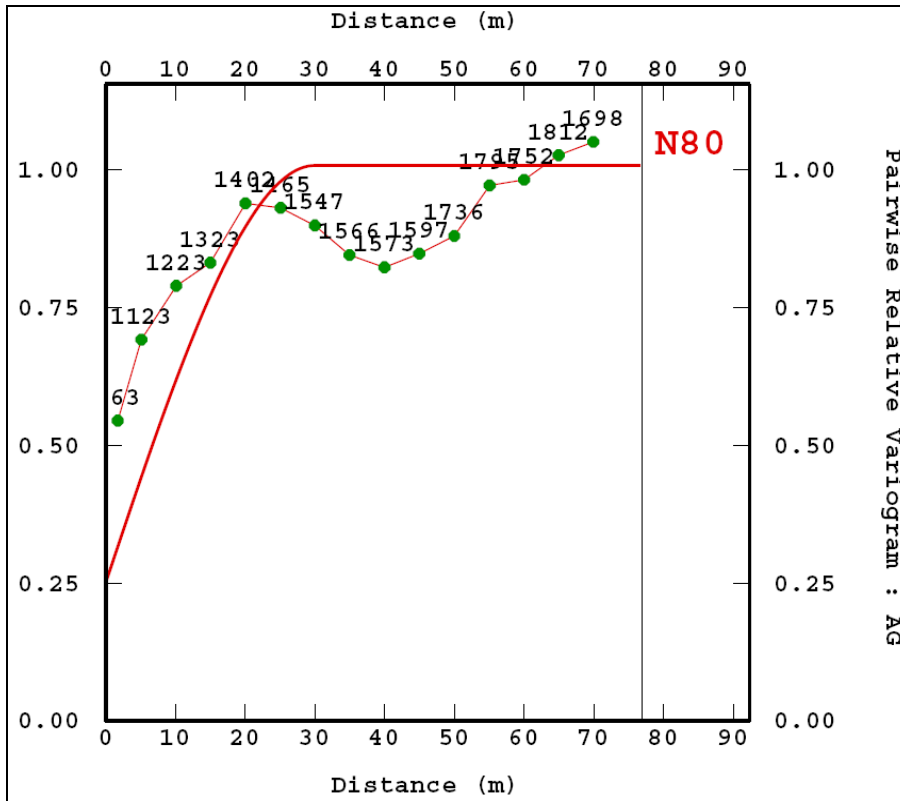

Figure 17.8: Variograms Modelled by SRK for the Silver Composites. Top: Parallel to Strike. Bottom: Parallel to the Dip Direction

17.3.10 Estimation

SRK considers the inverse distance approach a robust estimation methodology that is appropriate for estimating grades for the Bellekeno Southwest and East Zones. Silver, lead, and zinc grades only from drill core composites within the each solid were used for estimating grades. Estimation ranges for gold were assumed to be the same as gold and lead ranges (shortest). Estimation ranges for PSG were assumed to be the same as zinc ranges (longest).

For the East zone, a high grade “shoot structure” modelled by Alexco was used as a hard boundary in grade estimation; only composites inside the “shoot structure” were used to estimate grades for blocks in this structure. Composites outside of the structure but inside the East zone were used to estimate blocks outside of the structure.

Estimation strategy for both Southwest and East Zones consisted of two estimation runs. The first estimation run utilized an estimation ellipse based on variogram ranges and orientations. Estimation ranges in the normal or “thickness” direction were assumed to be fifteen metres for all metals and PSG. A minimum of two composites were required to estimate a block grade with a maximum of eight composites for this run. Octant search parameters were not used. Estimation ranges for length weighted pulp specific gravity values were assumed to the same as silver estimation ranges.

The second estimation run consisted of using twice the variogram ranges with the same orientations; only blocks that were not estimated in the previous run were updated. A minimum of one composite was required to make an estimate with a maximum of eight composites. Octant search parameters were not used.

SRK has established that core specific gravity varies significantly in the Southwest Zone. The distribution of core specific gravity measurements is not sufficient to estimate specific gravity values directly for each block. SRK assumed that a relationship exists between pulp specific gravity and core specific gravity measurements, based on twenty-nine intervals where both core specific gravity and pulp specific gravity measurements are available. This linear regression has a correlation coefficient of 0.70. This regression relationship (Figure 17.9) was used to estimate specific gravity values for each block with a pulp specific gravity value. The regression line equation used to estimate block specific gravity (“SG”) is:

$$SG = PSG * 0.675089 + 0.1.2953614, \text{ where PSG is pulp specific gravity.}$$

As a check of block specific gravity estimates, a scatter plot was used to check if a reasonable linear relationship between the two variables was maintained in the block estimation process. Correlation between the two estimated variables is about 0.95. The plot (Figure 17.10) indicates that a reasonable linear relationship between lead and block specific gravity has been maintained in the estimation process.

An average core specific gravity of 3.65 was assumed for the East Zone grade block model.

Areas mined out by UKHM were excluded from the block model used for the final estimation of the mineral resources in the Southwest Zone.

Mineralization at Bellekeno is zoned from the southwest to the northeast of the deposit. Southwest Zone mineralization is dominated by silver and lead mineralization. Correspondingly, East Zone mineralization is dominated by zinc with subordinate silver and lead mineralization. Reporting resources for both deposits using silver cut-off grades used in the previous SRK (2007) resource estimate would understate the potential of the East zone. Reporting mineral resource using silver equivalent grades is more appropriate for zoned polymetallic deposits like Bellekeno.

SRK calculated silver equivalent grades (“AgEq”) using the following assumptions:

- Metal prices: US\$8.00 silver per troy ounce, US\$1.00 per kg (\$0.45 per pound) lead, US\$1.65 per kg (\$0.75per pound) zinc;
- Metallurgical recovery factors have been assumed to be 100%;
- Gold was not used in silver equivalent calculation as it adds minor value and has not been assayed for all intervals.

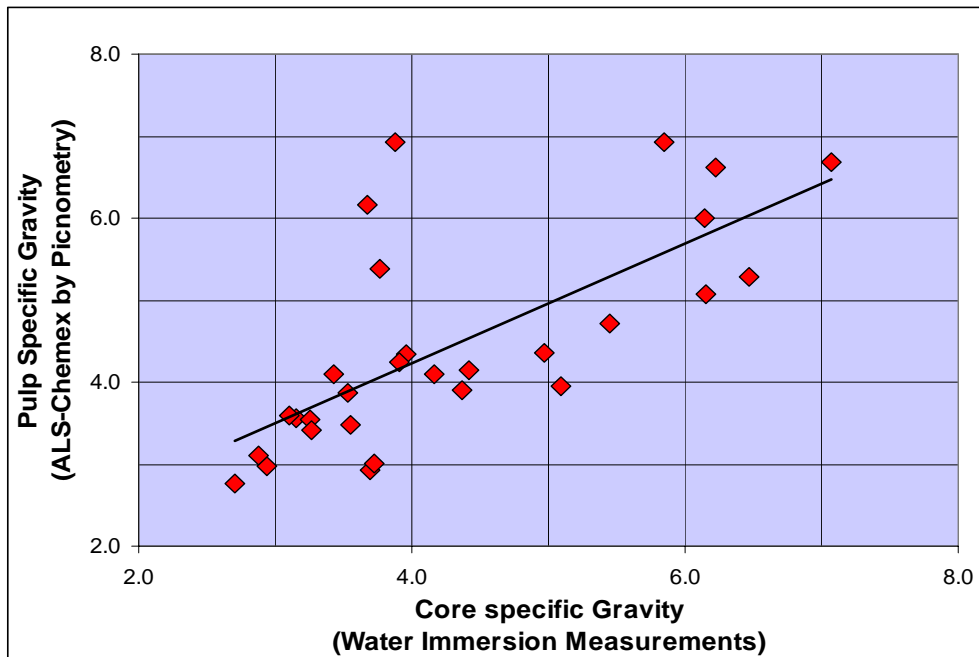

Figure 17.9: Linear Regression Relationship between Core and Pulp Specific Gravity Determinations.

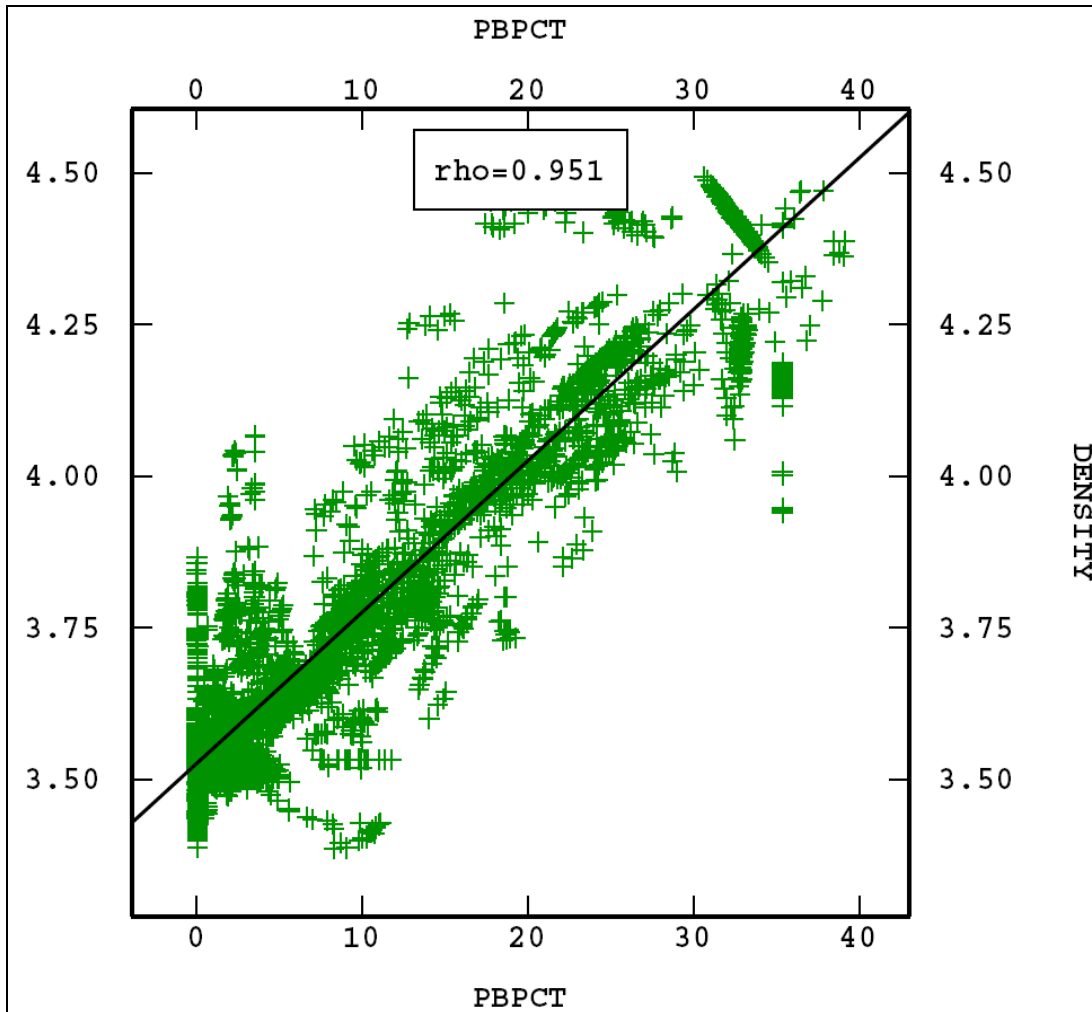

Figure 17.10: Relationship between Estimated Block Specific Gravity (DENSITY) and Block Lead Grade in Percent (PPBPCT).

17.3.11 Estimation Validation

Estimation methodology was validated by visually comparing block grades to composite drill holes and uncomposited drill holes. Block grades were found to correlate reasonably with composites and generally with uncomposited grades for both Southwest and East Zone estimates.

As an additional check of estimation methodology, the block model was estimated with nearest neighbour and inverse distance squared techniques using the same estimation parameters. The nearest neighbour estimator is a theoretically unbiased estimator at no cut-off grade and therefore, is a good check of the global estimate. The nearest neighbour estimate for the Southwest Zone at no cut-off grade had grade differences ranging from 13% for zinc and 7% for silver. The East zone nearest neighbour comparison results in a maximum grade range of 5% or less.

The inverse distance squared estimator for the Southwest zone estimated the same tonnage, along with grade variations of less than 5% at an AgEq cut-off of 1,000 g/t, as the resource estimate. For the East zone tonnage was underestimated by 11% and grades varied by less than 11%.

Validation methods indicate that the estimation method used by SRK is appropriate and delivers reasonable estimates for the silver, gold, lead and zinc grades and tonnages for the Southwest Zone of the Bellekeno deposit.

17.3.12 Sensitivity Analysis

A sensitivity analysis on the current (January 28, 2008) resource estimate for the Bellekeno East and Southeast zones has been completed to investigate the impact of the assumptions considered for construction of the mineral resource model and to assist in identifying alternative assumptions to be taken into consideration for future resource estimation work. This analysis is not intended to provide an alternate mineral resource model for the Bellekeno Southwest and East zones. The analysis focuses on the estimated metal grades for silver, lead and zinc. Gold was not considered.

Significant uncertainties in the mineral resource estimate for the East and Southeast zones exist. For these reasons, all the mineral resources have been classified as Inferred according to the CIM Definition Standards for Mineral Resources and Mineral Reserves (December 2005). The main uncertainties are derived from the following factors:

- Widely spaced drill holes;
- Bulk of resources are defined by only a few drill holes;
- Density estimates for the deposit are based on limited data and require larger data sets;
- Limited reliable data for variography;
- Limited geological data for each zone.

Changes to any these factors with additional exploration drilling and underground development are likely to result in significant changes to the mineral resource model for the Southwest and East zones. Such changes are likely to have a much greater impact than the effect of any estimation assumptions discussed in this sensitivity analysis. In light of this, the sensitivity analysis results should be considered as a qualitative analysis of the robustness of the current mineral resource statement, and not a quantitative analysis.

In developing the Southwest Zone grade model, SRK identified that core recovery and specific gravity are of critical importance, because they impact directly on the tonnage, grade and metal content of the estimates. SRK considered each parameter as additional weighting factors and generated full intersection length composites for the deposit. Missing pulp specific gravity values in historical and Alexco data were estimated based on a linear regression relationship established between lead and pulp specific gravity. The effect of each of these variables was modeled by generating composite data sets that were weighted separately by specific gravity and core recovery

in addition to the required length weighting. These composites were then used to generate separate block models using the same estimation parameters as for the stated mineral resource model. To analyze the effect of estimating block specific gravity from estimated pulp specific gravity, SRK also estimated a block model using only length weighted composites and assigning to each block an average of specific gravity based on an average of all core specific gravity measurements.

For the East Zone model, only core recovery and length weighting was used because there is no clear relationship between specific gravity and grade. Pulp specific gravity measurements are not available for all assayed intervals and the correlation between grade and pulp specific gravity is poor, preventing the calculation of missing values based on a linear regression relationship. The effect of core recovery was investigated by generating a length weighted composite data set and estimating a separate grade block model using the same estimation parameters as for the stated mineral resource model (without considering core recovery).

The sensitivity of the resource model for the Southwest zone to core recovery and specific gravity weighting is summarized in Table 17.15 as a percentage variation between the two estimates expressed at a cut-off grade of 500 g/t silver. The quantities and grades for each model are presented in Table 17.16. Density weighted composites show significant increases in grade from 18% to 24% as may be expected in material with a higher density. Tonnage differences are minor with an increase of only 3%. Recovery weighted composites, as may be expected, have a generally negative effect on grades and tonnage ranging from 12% decrease in grades and 8% decrease in tonnages. Minor lower grades increases of 2% and 5% for gold and zinc respectively reported at the 500 g/t silver cut-off grade do not reflect the general decreasing grade for these variables when the full range of cut-off grades are considered. The estimates based on length weighted composites using an average specific gravity for the entire zone deliver generally higher grades ranging from 9% to 27%, but with a significant reduction in tonnage of about 15%.

Table 17.15: Tonnage and Grade Sensitivity Results for Southwest Zone, Percentage of Resource Model*

Composite and Estimate Type	Sensitivity (%)				
	Tonnage	Ag Grade	Pb Grade	Zn Grade	Au Grade
Density and Length Weighting, Block Density Estimate [†]	3%	24%	26%	18%	22%
Core Recovery and Length Weighting, Block Density Estimate [†]	-8%	-12%	-12%	5%	2%
Length Weighting, Average Density [†]	-15%	9%	10%	24%	27%

*Tonnage and grade estimate for sensitivity analysis not a statement of mineral resources. All figures have been rounded to reflect the relative accuracy of the estimates.

[†]Cut-off of 500 grams per tonne silver. Grades not capped. Mined out material not removed from model.

Table 17.16: Tonnage and Grade Sensitivity Results for Southwest Zone*

Composite and Estimate Type	Sensitivity				
	Tonnage (t)	Ag Grade (g/t)	Pb Grade (%)	Zn Grade (%)	Au Grade (g/t)
Resource Model [†]	315,000	1,330	20.0	5.2	0.4
Density and Length Weighting, Block Density Estimate [†]	324,800	1,652	25.2	6.2	0.5
Core Recovery and Length Weighting, Block Density Estimate [†]	288,200	1,176	17.5	5.5	0.4
Length Weighting, Average Density [†]	267,400	1,451	21.9	6.4	0.5

*Tonnage and grade estimate for sensitivity analysis not a statement of mineral resources. All figures have been rounded to reflect the relative accuracy of the estimates.

[†]Cut-off of 500 grams per tonne silver. Grades not capped. Mined out material not removed from model.

The sensitivity analysis shows that for the Southwest Zone the overall effect of combining the positive impact of density weighting and the negative impact of recovery weighting is an estimate that is between these two extremes. The analysis also shows that the mineral resource estimate derived from the combined density and core recovery weighting does not contrast significantly from an estimate based on length weighting and average specific gravity value (about 15%). SRK concludes it is very appropriate to consider specific gravity and core recovery weighting for estimating the mineral resources for the Southwest Zone. The sensitivity analysis provides additional comfort on the robustness of the assumptions considered, giving the uncertainty levels expected for an inferred mineral resource estimate.

The sensitivity of resource model for the East Zone to core recovery weighting is summarized in Table 17.17 as percentage changes from the mineral resource model at a cut-off grade of 500 g/t silver. The quantities and grades estimates are presented in Table 17.18. The analysis shows that core recovery weighting has a general negative impact on both tonnage and grade, as expected. The impact is an increase in grades from 2% to 18% and an increase in tonnage by 48% when core recovery is not considered as a composite weighting factor. The large contrast in tonnage between the two estimates is probably accentuated by the fact that the East Zone is more a high grade zinc deposit rather than a high grade silver-lead deposit like the Southwest Zone. These differences are apparent at all silver cut-off grades considered.

Table 17.17: Tonnage and Grade Sensitivity Results for East Zone, Percentage of Resource Model*

Composite Type	Sensitivity				
	Tonnage	Ag Grade	Pb Grade	Zn Grade	Au Grade
Length Weighting [†]	42%	2%	4%	13%	18%

*Tonnage and grade estimate for sensitivity analysis not a statement of mineral resources. All figures have been rounded to reflect the relative accuracy of the estimates.

[†]Cut-off of 500 grams per tonne silver. Grades not capped. Mined out material not removed from model

Table 17.18: Tonnage and Grade Sensitivity Results for East Zone*

Composite and Estimate Type	Sensitivity				
	Tonnage [t]	Ag Grade [g/t]	Pb Grade [%]	Zn Grade [%]	Au Grade [g/t]
Resource Model [†]	32,900	708	3.7	6.2	0.3
Length Weighting [†]	46,700	722	3.8	7.0	0.3

*Tonnage and grade estimate for sensitivity analysis not a statement of mineral resources. All figures have been rounded to reflect the relative accuracy of the estimates.

[†]Cut-off of 500 grams per tonne silver. Grades not capped. Mined out material not removed from model

The sensitivity analysis shows that for the East zone core recovery weighting will provide a conservative estimate if not combined with specific gravity weighting. SRK notes that the magnitude of the differences outlined in this study may arise from differences in deposit mineralogy rather than from the estimation parameters only.

SRK concludes that resource estimation for the Bellekeno deposit can benefit from better drilling practices that will improve the core recovery, better resolution in core recovery measurements and with additional pulp specific gravity measurements. In the latter case, SRK strongly recommends that pulp specific gravity be routinely acquired from the laboratory for each sample submitted for assaying within and at the peripheries of the vein mineralization.

Most of the core recovery data used for resource estimation is derived from measurements taken for each core run, at approximately 3 m intervals. Core recovery should be measured for each sampling interval separately to allow core losses to be attributed directly each assay interval. SRK believes that this may result in a less aggressive weighting of assays in the compositing process. As well, by attributing core loss to specific intervals it may be possible to differentiate real core losses due to voids in the mineralization from those arising from drilling problems or mineralization characteristics. In the later case, mineralization occurring as “galena sands” could be flagged separately and considered as having a high or low core recovery.

Pulp specific gravity measurements should continue to be measured for the Bellekeno and other similar deposits in the Keno Hill district. Although available data for the East zone suggests a poor relationship between grade and specific gravity, SRK believes that this should not preclude specific gravity weighing. SRK suggests that pulp specific gravity measurements for available historical drill core should also be considered. Specific gravity for various mineralization types needs to be examined as part of the underground exploration program.

17.3.13 Mineral Resource Classification

Mineral resources have been estimated in conformity with generally accepted CIM “Estimation of Mineral Resource and Mineral Reserves Best Practices” Guidelines. Mineral resources are not mineral reserves and do not have demonstrated economic viability.

The mineral resources estimated for the Bellekeno Southwest Zone and East Zone were classified according to “CIM Definition Standards for Mineral Resources and Mineral Reserves” (December 2005) by G. David Keller, P. Geo. a Qualified Person as defined by NI 43-101.

In classifying the mineral resources for the Southwest Zone, SRK considered that:

- Drill hole spacing over the deposit varies widely from 10 m to 50 m and is not evenly spaced over the deposit area;
- The bulk of the Southwest Zone estimated silver resources are supported by only four drill holes spaced approximately 50 m and 15 m apart;
- Density variations of the deposit are critical to this type of deposit, density estimates for this deposit are based on limited data sets and assumptions that need to be demonstrated with greater confidence from large data sets;
- Because of limited data for the zone, variography is based on the entire Bellekeno vein. There are significant variations in grade characteristics (particularly lead and zinc) in the Bellekeno vein across strike and possibly with depth across the deposit. The effect of these large scale variations on variography of the southwest may be positively or negatively significant;
- Limited geological information was used in the delineation of the zone.

Considering these parameters, SRK is of the opinion that the mineral resources for the Bellekeno Southwest Zone are appropriately classified as Inferred Mineral Resources.

17.3.14 Bellekeno Southwest and East Mineral Resource Statement

Mineral resources for the Bellekeno East Zone have been estimated at 179,600 tonnes at 263 g/t silver, 0.4 g/t Au, 2.0 percent lead, and 21.3 % zinc using a silver equivalent cut-off grade of 1,000 g/t. In addition, resources for the Bellekeno Southwest Zone have been re-estimated and restated in terms of a silver equivalent cut-off grade. Mineral resources for this zone are estimated at 302,100 tonnes at 1,357 g/t silver, 0.4 g/t gold, 20.4 percent lead and 5.5 percent zinc using a silver equivalent cut-off grade of 1,000 g/t. These resources are classified as Inferred Mineral Resources following the CIM Definition Standards for Mineral Resources and Mineral Reserves (December 2005) guidelines.

The revised mineral resource statement for the Bellekeno Southwest and East zones are tabulated in Table 17.19.

Table 17.19: Mineral Resource Statement* for the Bellekeno Southwest and East Zones (SRK Consulting, January 28, 2008)

Category	Zone	Tonnage (t)	Ag (g/t)	Pb (%)	Zn (%)	Au (g/t)	AgEq (g/t)
Inferred	Southwest ^{†‡}	302,100	1,357	20.4	5.5	0.4	2,494
Inferred	East ^{†‡}	179,600	263	2.0	21.3	0.6	1,698

* Mineral resources are not mineral reserves and do not have demonstrated economic viability. All figures have been rounded to reflect the relative accuracy of the estimates.

† Reported at a cut-off of 1000 grams per tonne silver equivalent. Grades not capped.

** Metal price and recovery factor assumptions for resource are: US\$8.00 Silver troy ounce, US\$1.00/kg (US\$0.45 per pound) Lead, US\$1.65/kg (US\$0.75 per pound) Zinc, metallurgical recovery factors have been assumed to be 100%. Gold was not used in silver equivalent calculation.

The mineral resources at various silver equivalent cut-off grades for the Bellekeno Southwest and East Zone are presented in Table 17.20 and Table 17.21.

Table 17.20: Tonnage and Grade at Various Cut-off Grades Southwest Zone

AgEq Cut-Off (g/t)	Ag (g/t)	Tonnage (t)	Au (g/t)	Tonnage (t)	Pb (%)	Tonnage (t)	Zn (%)	Tonnage (t)	AgEq (g/t)	Tonnage (t)
800.00	1,215	358,000	0.4	358,000	17.9	358,000	5.3	358,000	2,242	358,000
1000.00	1,357	302,100	0.4	302,100	20.4	302,100	5.5	302,100	2,494	302,100
1200.00	1,407	283,900	0.4	283,900	21.3	283,900	5.5	283,900	2,585	283,900

Table 17.21 Tonnage and Grade at Various Cut-off Grades East Zone

AgEq Cut-Off (g/t)	Ag (g/t)	Tonnage (t)	Au (g/t)	Tonnage (t)	Pb (%)	Tonnage (t)	Zn (%)	Tonnage (t)	AgEq (g/t)	Tonnage (t)
800.00	274	219,800	0.5	208,900	2.1	208,900	18.8	219,800	1,552	219,800
1000.00	263	179,600	1.0	168,700	2.0	168,700	21.0	179,600	1,698	179,600
1200.00	246	154,700	0.6	144,800	1.9	144,800	23.2	154,700	1,797	154,700

17.4 Consolidated Mineral Resource Statement for the Bellekeno Deposit

Combined mineral resources for the Bellekeno deposit, including previously disclosed mineral resources for the Bellekeno 99 zone, total 537,400 tonnes grading 1,016 g/t silver, 13.5 % lead and 10.7 % zinc for 17.6 Moz of contained silver or 38.3 Moz contained silver equivalent. This represents a 51 % increase in tonnes (181,400 tonnes) and a 19 % increase in silver equivalent ounces (6.1 million silver equivalent ounces) compared to the prior SRK resource estimates in January 28, 2008. The consolidated mineral resource statement is presented in Table 17.22.

Table 17.22: Consolidated Mineral Resource Statement* for the Bellekeno Deposit, (SRK Consulting, January 28, 2008)

Category	Zone	Tonnage (t)	Ag (g/t)	Pb (%)	Zn (%)	Au (g/t)	AgEq (g/t)
Inferred	99 [†]	55,700	1,593	11.1	5.5	0.0	2,375
	Southwest ^{†**}	302,100	1,357	20.4	5.5	0.4	2,494
	East ^{†**}	179,600	263	2.0	21.3	0.6	1,698
Total Inferred		537,400	1,016	13.5	10.7	0.4	2,216

* Mineral resources are not mineral reserves and do not have demonstrated economic viability. All figures have been rounded to reflect the relative accuracy of the estimates.

† Reported at a cut-off of 15 troy ounces per ton silver. Silver grades capped at 100 troy ounces per ton.

‡ Reported at a cut-off of 1000 grams per tonne silver equivalent. Grades not capped.

** Metal price and recovery factor assumptions for resource are: US\$8.00 Silver troy ounce, US\$1.00/kg (US\$0.45 per pound) Lead, US\$1.65/kg (US\$0.75 per pound) Zinc, metallurgical recovery factors have been assumed to be 100%. Gold was not used in silver equivalent calculation.

The economic analysis explained in this report uses inferred mineral resources exclusively. Inferred mineral resources are considered too speculative geologically to have the economic considerations applied to them to be categorized as mineral reserves, and there is no certainty that the preliminary assessment will be realized.

17.4.1 Bellekeno Resource Model

SRK has provided a new Bellekeno resource model based on recent drilling in the Bellekeno Southwest and East mineralized zones. In addition, SRK audited Alexco Resource’s in-house audit of the polygonal blocks in the 99 zone. As a result of SRK’s work, a NI 43-101 compliant inferred mineral resource estimate was published in December of 2007 and revised January 28, 2008 and revised again March 13, 2008 to include the East zone mineralized material. Table 17.22 is the compliant NI 43-101 estimate. For documentation of resource estimation methodology please refer to the SRK Report (Mineral Resource Estimation, Bellekeno Project, Yukon Territory, Canada, SRK Consulting, November 10th, 2007).

Figure 17.11 is an SRK silver equivalent (AgEq) block model long section of the new Bellekeno model. The AgEq values are ranked with highest values depicted as the “hottest” magenta color. The current cut off grade (“COG”) is >1,000 g/t AgEq. In contrast, the centrally located historic 99 zone was tabulated using a 514 g/t Ag COG as validated by SRK.

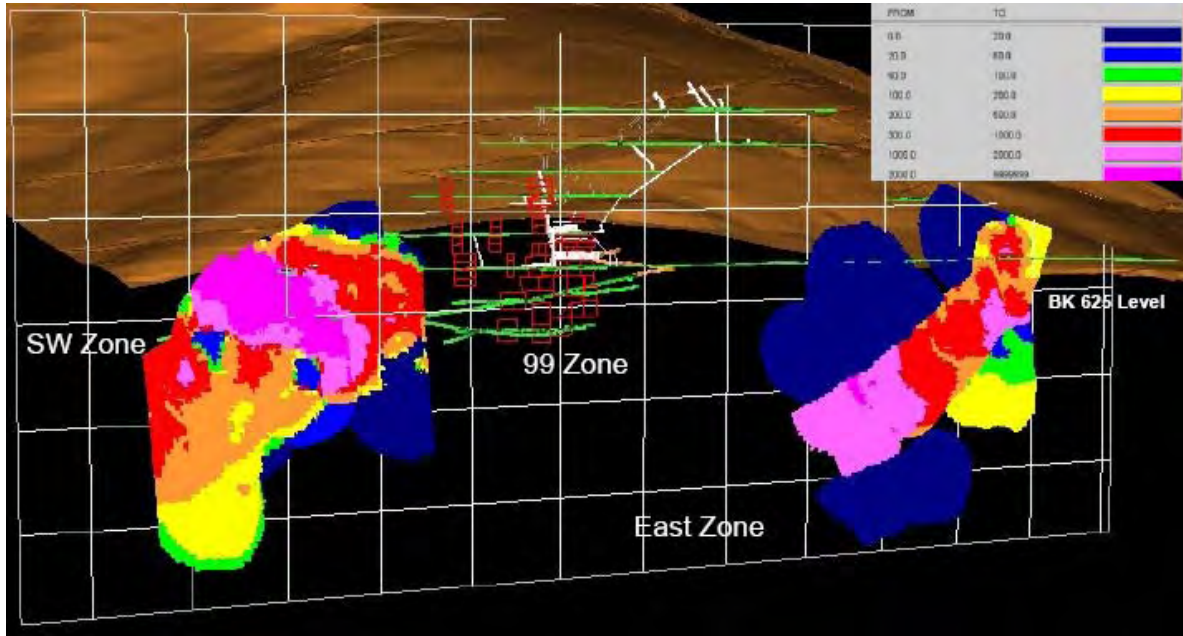

Figure 17.11: Longitudinal View of Bellekeno Deposit showing AgEq Block Model Values

17.5 Life of Mine Plan Resource Estimate

17.5.1 Recovery and Dilution

To develop a PEA-level LOM plan, mining dilution (over-break and backfill dilution) was applied to the mineral resource estimate blocks. Over-break dilution for Bellekeno is calculated at 12%. The mining at Bellekeno will utilize backfill and fill dilution was calculated at 2%. Overall mining recovery is assumed to be 100%.

17.5.2 LOM Plan Tonnes

The LOM plan for Bellekeno has been enhanced by grade and tonnage estimates from recent drilling (2007). Specifically, the East Zone of the Bellekeno deposit has demonstrated down plunge and down dip continuity (Figure 3.1). After being adjusted for 14% dilution (lower grade and higher tonnage), the LOM plan resource at Bellekeno is as shown in Table 17.23

Table 17.23: Bellekeno Life of Mine Plan Diluted Tonnes and Grade

Category	Zone	Tonnage	Ag	Pb	Zn	Au
		(t)	(g/t)	(%)	(%)	(g/t)
Inferred	99	64,000	1,397	9.7	4.8	0.0
	Southwest	344,000	1,190	17.9	4.8	0.4
	East	205,000	231	1.8	18.7	0.5
Total Tonnes, Ave. Grades		613,000	890	11.6	9.6	0.3

18 Other Relevant Data and Information

18.1 General Site Infrastructure

Most of the main infrastructure, services, and facilities for the project are available at the existing Elsa Mill site. The additional ancillary facilities that will be required should mine and mill construction go ahead are:

- Water supply and distribution;
- Assay laboratory;
- Temporary construction facilities;
- Electrical (additional power supply and distribution).

Specific mine and mill infrastructure are described in Sections 19.1.17 and 16.5.5, respectively.

18.1.1 Water Supply and Distribution

Domestic water is currently pumped from a cistern buried in Flat Creek via insulated-heat traced pipeline to a water treatment facility about 100 metres to the north. The treatment plant consists of 5,000 litres of storage, a water softener, UV treatment and chlorination. Monthly samples are submitted for analyses for toxic metals, bacteria and hydrocarbons.

Alexco has two sewer permits at Elsa; one for the Flat Creek Camp and one for the four houses. Waste water is treated in septic tanks and released via drain fields.

There is currently a permit to store sewage in holding tanks at the Administration Building. These tanks are periodically pumped and transported to the Mayo waste water treatment plant for disposal.

Fresh Water Supply System

Fresh and potable water for the mill will be supplied to a 10 m diameter by 10 m high storage tank from two ground water wells.

Fresh water will be used primarily for the following:

- Firewater for emergency use;
- Cooling water for mill lubrication system;
- General mill water supply.

By design, the fresh water tank will be full at all times and will provide at least two hours of firewater in an emergency.

The potable water from the fresh water source will be treated (by chlorination and filtration) and stored in a 2 m diameter by 2 m high tank prior to delivery to various service points.

Process Water Supply System

Process water will consist primarily of reclaim water from the water polishing pond, as well as fresh water, concentrate thickener overflow, and water from the underground mine. The reclaimed water will be directed to a 7 m diameter by 7 m high process water storage tank, from where the water will be dispersed to the distribution lines in the process plant. Approximately 49 m³/h of water will be necessary for the process operation including water from thickener overflow.

18.1.2 Assay Laboratory

A metallurgical & assay laboratory will conduct daily mine, mill and environmental quality control and optimize process performance.

The assay laboratory will be equipped with necessary analytical instruments to provide all routine assays for the mine, the plant, and environmental monitoring. The main analytical tool will be an atomic absorption spectrophotometer (AAS).

The metallurgical laboratory will undertake all basic test work to monitor metallurgical performance and to improve process flow sheet and efficiency. The laboratory will be equipped with laboratory crushers, ball mills, particle size analysis devices, flotation cells, filtering devices, balances, and pH metres.

18.1.3 Temporary Construction Facilities

A construction office complex supplied with temporary power, water supply, and sewage disposal will be used at the plant site to support construction for the project.

A construction lay down area, a contract aggregate screening plant, and a batch plant will be required. A suitable amount of aggregate material to supply construction is available from nearby sources.

18.1.4 Electrical Power

At the present time, the Keno Hill district obtains electrical power from a hydroelectric plant near Mayo. In the past, this facility had sufficient capacity to supply electricity to the mill and all of the various mines. However, after the closure of UKHM, Yukon Energy built a transmission line from Mayo to Dawson City and now the hydroelectric plant has only one megawatt surplus. It is estimated that one megawatt will not be enough electrical power to support the proposed mill and mine.

Yukon Energy stated that they could increase the generating capacity at the Mayo powerhouse by installing another pelton wheel/turbine, but this upgrade would take approximately two years to

complete, once the decision is made to do so. Supplemental diesel generated power at the Bellekeno mine site would have to be used in the interim.

As an alternate source of energy, in 2008, Yukon Energy plans to extend the power line from Carmacks to Pelly Crossing (106 kilometres) and Sherwood Copper Corporation’s Minto Mine. This extension will put Pelly Crossing and the Minto Mine on the main power grid connected to Whitehorse. An further extension from Pelly Crossing to Stewart Crossing would only be 72 km at which point a connection to the Mayo to Dawson City transmission line could be made, tying Elsa and Keno City into the main Yukon grid.

A single-line diagram of the electrical system is shown in Figure 18.1.

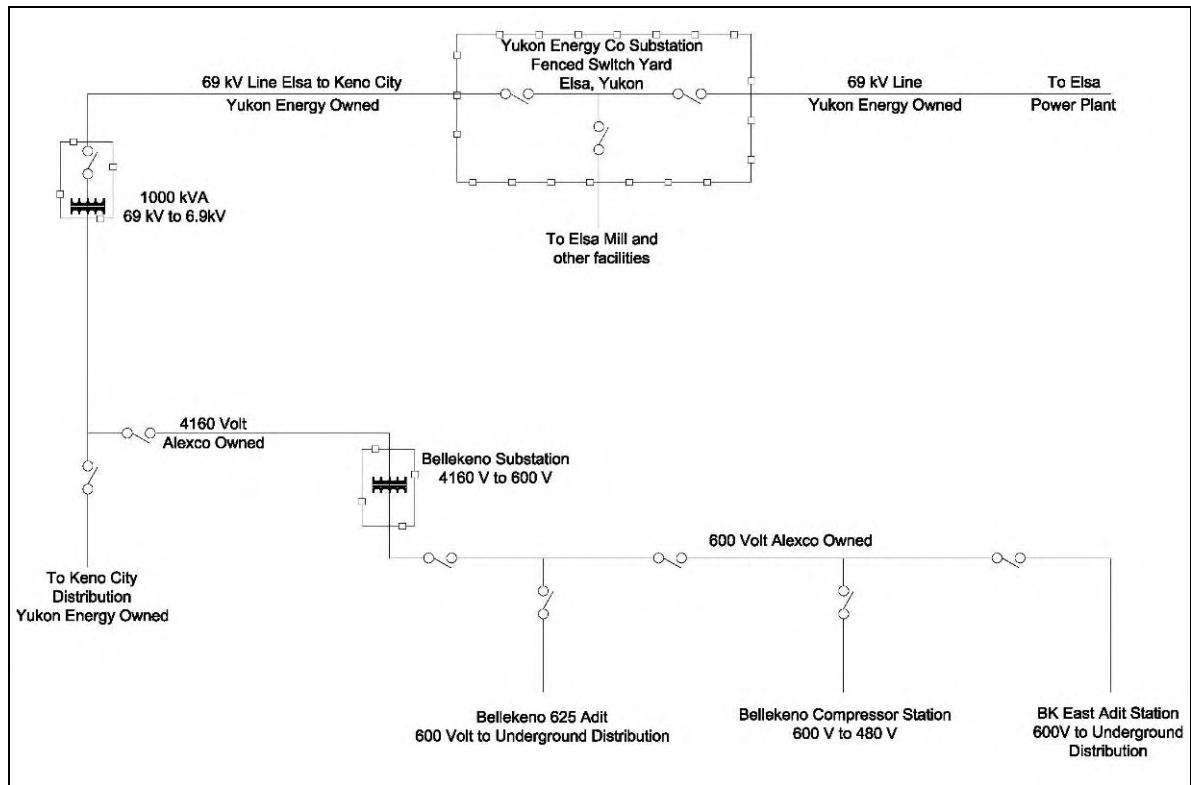

Figure 18.1: Bellekeno Electrical Single-line Diagram

Alexco owns several substations in the district, including the Elsa Substation, the Onek Substation, and the Bellekeno 625 Portal Substation. It also owns the transmission line connecting the latter two. All substations, especially the Onek Substation, will require thorough inspections and assessments before any substantial use is made of them. Much of the equipment in these substations is probably 1950 vintage, and may need to be replaced. Reportedly, some of the components are overheating and causing power outages, especially during the winter.

The line between the Onek substation and the Bellekeno 625 Portal substation will require examination of poles to determine their stability. Two poles were replaced in 2007. The poles had rotted and snapped off during a windstorm.

Diesel powered generators will be used as a source of power at the BK East Portal and the new underground workings until the road is completed to the Bellekeno 625 Portal. A 600 volt “tech” cable, reclaimed from Alexco’s Brewery Creek Mine, will be laid from Bellekeno substation to the BK East portal, following the route of the new road. The portal is expected to have grid power in Q3 2008.

Power Loads

It is anticipated that approximately a maximum 2.5 MW of power will be needed for operations. The distribution breakdown is estimated to be:

- Bellekeno Mine 0.75 MW
- Mill, Camp and Surface 1.5 MW

Current cost for grid power at the Elsa town site is \$.15/kWhr. It is expected that diesel-generated power will be in the order of \$0.25 to \$0.35/kWhr.

Backup Power

The Hamlet of Elsa has diesel capable backup power generation consisting of:

- 1 ea. 400 kW, 500 kW and 600 kW in 2-1940 vintage Rustons generators and a 500kW Caterpillar genset.
- In addition there are three smaller gensets 2-350 kW, 1-325 kW and 1-250 kW.

Mine Electrical Power Distribution

The Bellekeno East decline will initially be powered by a 350 kW Caterpillar portable genset. Another 350 kW genset will be available as back-up during service or alternating service. If power loads exceed the two 350 kW gensets a 500 kW genset from the Elsa power building will be relocated to the Bellekeno East portal site. When Bellekeno is eventually put into production it will have a redundant 4,160 V distribution system, fed from the portal or possibly a ventilation borehole.

The underground feeds from surface to the main underground substation are sized for full mine loads with redundancy. The main underground substation will distribute power to the upper and lower levels of the mine via ramps or dedicated boreholes. Mobile 750 kVA transformers will be placed strategically throughout the mine and equipped with breaker feed to individual levels with the capability to isolate incoming and outgoing power to other levels. The power is required to feed ventilation, electro-hydraulic loads, pumps, possible CRF or paste plant, electric slushers, etc.

The calculated maximum running load for the underground operations at Bellekeno is less than 1 MW.

With the projected operating power load identified during the study represents surpassing the 1 MW of grid power currently available, interim electrical power will come from diesel generators. This will lead to a short-term increase in power costs until additional grid power can be brought on line from the Mayo hydro-electric facility.

If the mine's electrical power needs are fully met with grid power, back-up diesel generators will still be maintained to ensure the continuity of critical items (camp facilities, heat tracing, ventilation fans, pumps, etc.).

A complete electrical power plan will need to be developed during the feasibility study.

18.1.5 Housing

Alexco owns a modern 72-person trailer camp at Flat Creek, located approximately one kilometre southwest of Elsa. This facility has individual rooms, male and female washroom facilities, a laundry room and a TV-recreation room. The kitchen/dining/storage facility is are equipped to feed approximately 120 persons. The dining facility will seat approximately 35 persons at one time. The Flat Creek facility is sufficient for the exploration program, including the decline development, and can be expanded for the Bellekeno operations.

Four five-bedroom houses located in Elsa were remodelled in 2007. These houses are used for professionals and more permanent staff. Each house is equipped with a full kitchen and laundry facility. A total of 20 persons can be comfortably accommodated in these houses, with a maximum occupancy of about 28.

Alexco has entered into a contract with ESS/NND (a joint venture between Compass Canada and Na-cho Nyak Dun Development Corporation) to provide catering services to the people working on the project. They are responsible for ordering supplies, preparing and serving three meals per day and housekeeping in the Flat Creek Camp. Workers who live in either Mayo or Keno City are able to eat at this facility.

18.1.6 Medical Facilities and First Aid

A Nursing Station is located in Mayo, approximately 57 kilometres from the Bellekeno Mine. This facility is staffed by two full-time nurses and an occasional physician/specialist. There is an ambulance at the nurse's station that is staffed by volunteers. All serious accidents/illness are stabilized in Mayo, and then taken by Air Ambulance to Whitehorse for further treatment.

At the present time, Alexco employs three Level 3 first aid attendants on rotating shifts to provide 24 hour per day first aid coverage. Alexco owns an ambulance that is stationed at Elsa. This ambulance is staffed by the first aid attendants and driven by Alexco employee volunteers. Patients are stabilized, and then transported to Mayo in Alexco's ambulance. For serious accidents/illnesses, dispatch of the ambulances are coordinated so that there is a transfer from the Alexco ambulance to the Mayo ambulance (if available) about halfway between Mayo and Elsa.

As the size of the project increases, first aid facilities will be upgraded at Elsa and higher levels of staffing will be retained.

18.1.7 Communications

Telephone communications at Elsa are via NorthWesTel “land” line. The system connects Elsa to a microwave station at the top of Galena Hill. Two lines are available on this system.

VOIP (Voice Over Internet Protocol) is available in Elsa. This system is reasonably portable and can be moved to locations that have power and a good “view” of the southern sky. It is possible that a VOIP system will operate at Bellekeno, but this has not confirmed.

A satellite telephone is available for emergency communications. This system is unreliable in northern latitudes and mountainous terrain.

FM radio communications are fair in the Keno Hill District. The FM facilities are being upgraded to include two repeaters which will allow a more consistent radio link between Elsa and Bellekeno and other parts of the district.

Internet is available via the VOIP system. Reasonable quality internet service is available at Elsa, and if VOIP service is established at the Bellekeno Mine, both phone and internet will be available at the mine site.

18.1.8 Access Roads

Access to the Keno Hill Mining District is very good. A paved highway connects Whitehorse to Mayo. Approximately five kilometres beyond Mayo, a publicly maintained, two-lane, all weather gravel road connects to Elsa and Keno City (53 kilometres). From Keno City, the Bellekeno Mine is reached via a private gravel road approximately 3.2 kilometres long. The mine road will be upgraded as the project advances. A new road will be constructed from the 625 Portal to the new BK East portal. This road will be approximately 800 m long and will be constructed from rock from the decline as it is driven.

18.1.9 Transportation and Shipping

Given the relatively good road network, transportation of goods and personnel is relatively straight forward, however, there are few transportation contractors operating between Whitehorse to Elsa.

All personnel working on the Keno Hill Project are on various rotation schedules. No attempt has been made to standardize the rotations and coordinate transportation accordingly. Currently, personnel living in Whitehorse (and southern Yukon) and out-of-Territory are flown via charter aircraft between Whitehorse and Mayo every fifth day. These flights, (approximately 70 minutes one-way), are scheduled to meet in-coming-out-going commercial flights to Whitehorse. The rotating crews then drive company vehicles to/from Elsa (45 minutes one-way). During the winter

and inclement weather, rotating crews drive between Elsa and Whitehorse (approximately 5 hours one way).

Alexco is negotiating with Na-cho Nyak Dun Development Corporation (NNDDC) to provide personnel transportation between Mayo and Elsa. This contract has not been finalized, but it is a priority issue that will be settled soon. Initially, it is envisioned that NNDDC will utilize a 24-passenger bus to transport local workers between Mayo and Elsa. This service will expand to meeting charter aircraft and possibly beyond.

As the project expands, additional schedules will be arranged as required and to other towns if the need arises.

Although many freight lines operate through Whitehorse, only one provides scheduled freight service to Mayo. During the summer months, this is a daily service, but during the winter, service is limited to packages with heavy items delivered on a fortnightly schedule.

Blindheim Trucking offers “on-request” freight service, and is used quite regularly to haul “less-than-truckload” and full loads between Elsa and Vancouver and elsewhere.

Alexco has an expeditor who brings freight from Whitehorse to Elsa twice a week and hauls core samples and other freight from Elsa to Whitehorse. Core samples are shipped via Canadian Freightways to Terrace BC.

Warehouse

Current warehouse facilities located at Elsa are adequate for future use.

19 Additional Requirements for Technical Reports on Development Properties and Production Properties

19.1 Proposed Mining Operations

19.1.1 Mining Context

Geotechnical Evaluation

A preliminary geotechnical evaluation was conducted to assess and characterize the East and Southwest zones, and the associated hanging and foot-wall zones for the proposed mining development. Based on this review, recommendations for mining type and stope design have been provided.

Information used for the geotechnical evaluation included:

- Microsoft Access drillhole database with all 2006 and 2007 drillholes from across the Bellekeno deposit (with RQD and recovery data);
- Core photographs for all 2006 – 2007 diamond drillholes;
- Gemcom geotechnical database with all drillholes (historic and recent), modeled zones, body shapes, and historic and proposed development;
- Rock strength and quality information provided by Alexco Resources including laboratory UCS testing, point load strength testing, and RQD histograms.
- SRK site visit information and mapping
- Geotech logging of the decline cover holes (Feb and March 2008)

All geotechnical descriptions have been interpreted from drillhole intersections of the zones and surrounding rockmass at the Bellekeno project.

District Scale Structure

District Faulting

High-angle faulting with dominantly northeast trends host most of the mineralized veins in the district. The vein structures are in turn faulted and displaced by late high-angle crosscutting faults trending northwest-southeast. In addition, there are numerous bedding plane slips primarily along the graphitic schist units. There have been low-angle faults, thrust or bedding plane faults documented in historical workings but their occurrence is low.

District Folding

The Keno district has undergone broad isoclinal folding and it appears to be single phase (F1). The broad folds are not significant in terms of rock quality or stability; however, there may be a coincidence to axial planer failure and the north-northeast trending mineralized veins.

Vein Faulting and Cross Faults

The 48 Vein and other veins at Bellekeno contain gouge and brecciated rock healed by siderite, quartz, sulphides and sulpho-salts.

The younger non-mineralized cross faults commonly contain gouge with quartz and carbonate infill and are considered poor ground. Large cross faults can be water bearing and when tapped can create hazardous and damaging inflows of water (when mining tapped the Brefalt Creek fault it nearly compromised the Husky shaft). To date no large cross faults have been identified in the immediate Bellekeno area.

Geological/Geotechnical Description

The Bellekeno mine is situated within three main lithological units consisting of schist, quartzite, and greenstone. Mineralization is vein hosted primarily within the quartzite unit. Figure 19.1 shows the proposed and historic Bellekeno development along with the lithological contacts. A brief description of each unit is given below.

Quartzite

The primary host for mineralized veins at Keno Hill is a fine grained, thin to thick bedded quartzite. The rock is often inter-layered with bands of dark coloured graphitic schist which ranges in thickness from knife-edge to a few metres. It is estimated that the proposed decline and drill lateral will be driven in quartzite approximately 60 to 70% of the time.

Schist

A variety of schistose rocks occur at Bellekeno mine, although all show similar geo-mechanical properties. Graphitic schist is the most abundant followed by sericitic schist and chloritic schist. Micaceous minerals form a large portion of this rock type along with fine grained quartz and occasional carbonate minerals. Schists are inter-banded with quartzite in both a rhythmic and sporadic manner throughout the lithologic section. Many of the larger schist bands show contorted foliation and even local tight isoclinal folding. Prediction of the location of schist bands is problematic as individual bands tend to pinch and swell along strike and dip. Schist is often the locus of minor or moderate fault movement producing gouge and generally incompetent ground conditions. It is estimated that the proposed decline and lateral will contain 15 to 20% schist mainly as narrow bands occasionally inter-layered with massive quartzite.

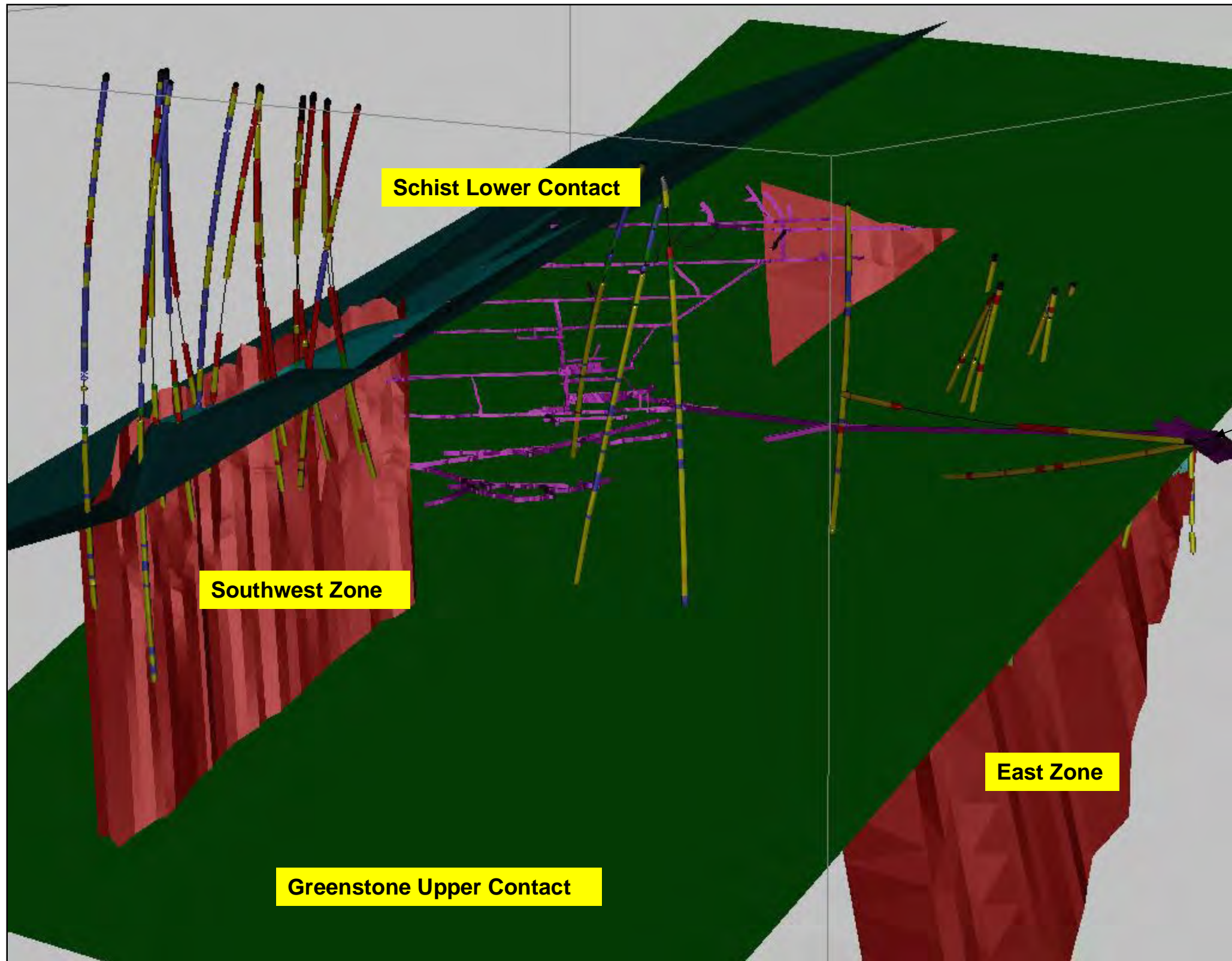

New Portal and Decline

Schist Lower Contact

Southwest Zone

East Zone

Greenstone Upper Contact



Bellekeno Project Geotechnical Evaluation			
Bellekeno Schematic: Historic and Proposed Development			
PROJECT: 2CA017.000	DATE: June 2008	APPROVED:	FIGURE: 19.1

Greenstone

A dark green igneous greenstone unit is occasionally inter-banded with both quartzite and schist at Bellekeno. In particular, a large tabular body approximately 90 m thick will be traversed by the proposed drill lateral for about 175 m. Where fresh, the greenstone is a compact, fine to medium grained rock showing an indistinct foliation and random jointing. Adjacent to mineralized veins the greenstone can be clay altered and less competent.

Geotechnical Domains

The geotechnical domain evaluation focused on data collected from the 2006 and 2007 diamond drilling campaign. All 128 drillholes from this program have RQD and recovery data, as logged by Alexco Resources personnel. Two decline pilot drillholes have detailed geotechnical data including RQD, recovery, fracture frequency (FF/m), intact rock strength (IRS), joint conditions, and oriented defect data.

From this data, 14 and 15 drillholes, intersecting the Southwest zone and East zone respectively, were selected for a more detailed geotechnical review. The details of this review are presented as Appendix C, and include RQD and core recovery plots, mineralization locations, and representative core photos for each drillhole reviewed. The location of the mineralized zones has been directly interpreted from the intersection of the geological solids (as modelled by SRK). It should be noted that in most locations this is the apparent thickness of mineralization.

Appendix C also provides section and plan views through each zone with the 2006 – 2007 geotechnical drillhole data (RQD and FF/m). Figures 19.2 and 19.3 show joint and bedding stereo nets from historic underground mapping at Bellekeno.

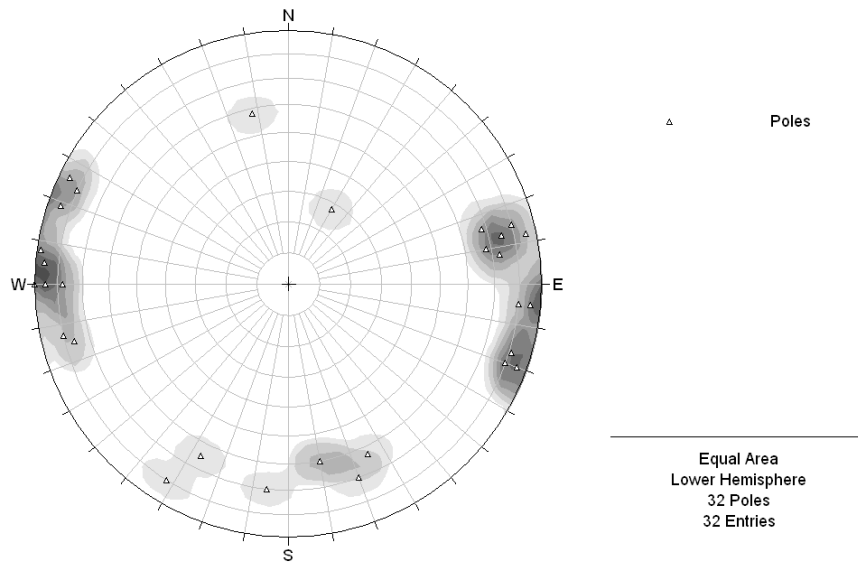

Figure 19.2: Joint Measurements from Historical UG Mapping at Bellekeno Mine

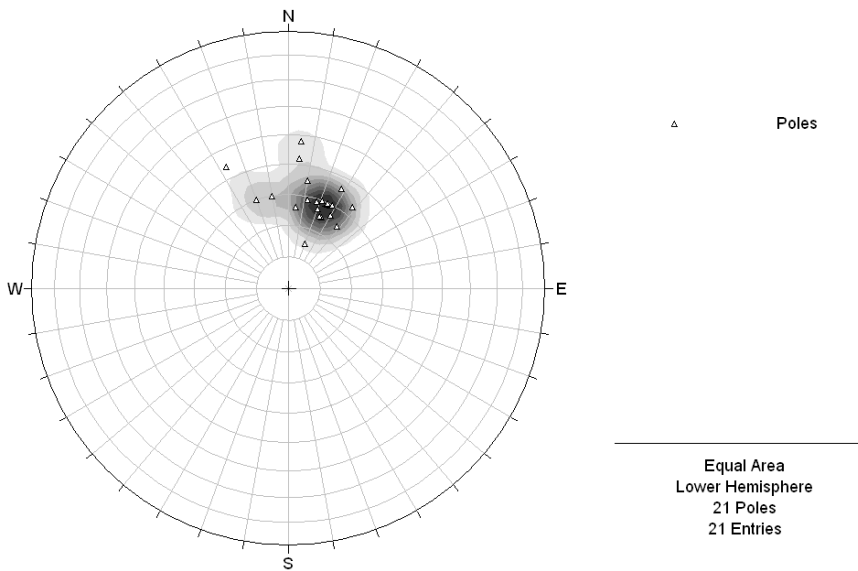
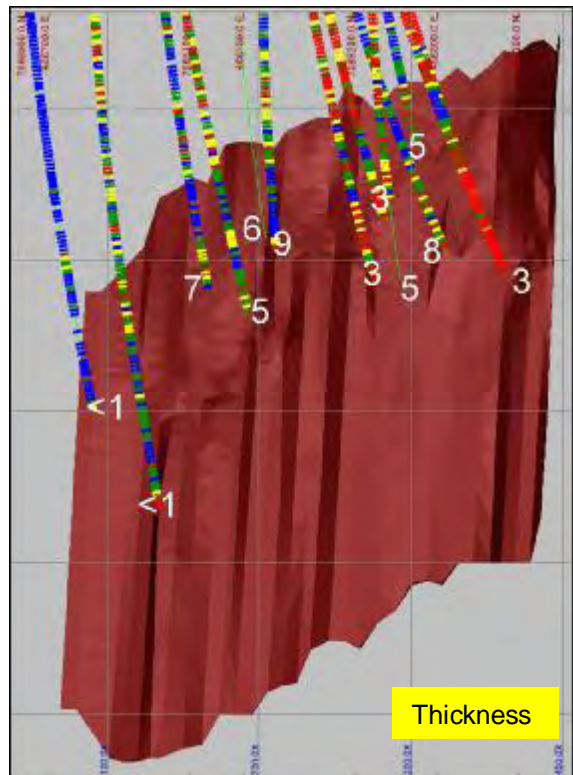
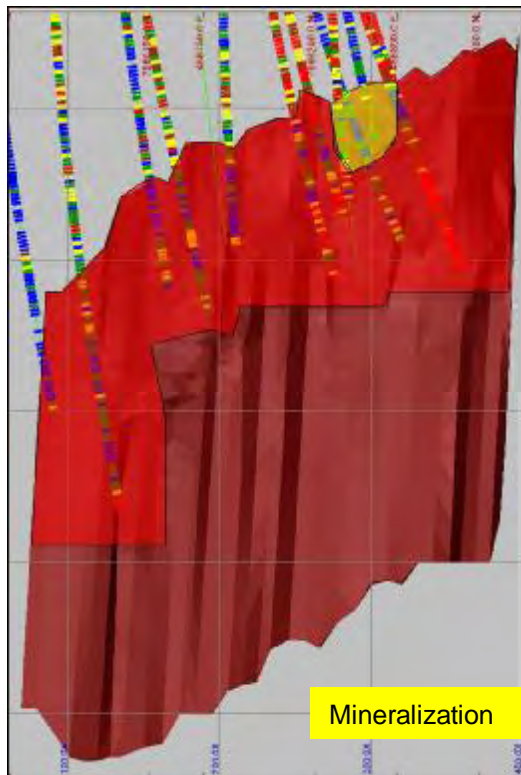
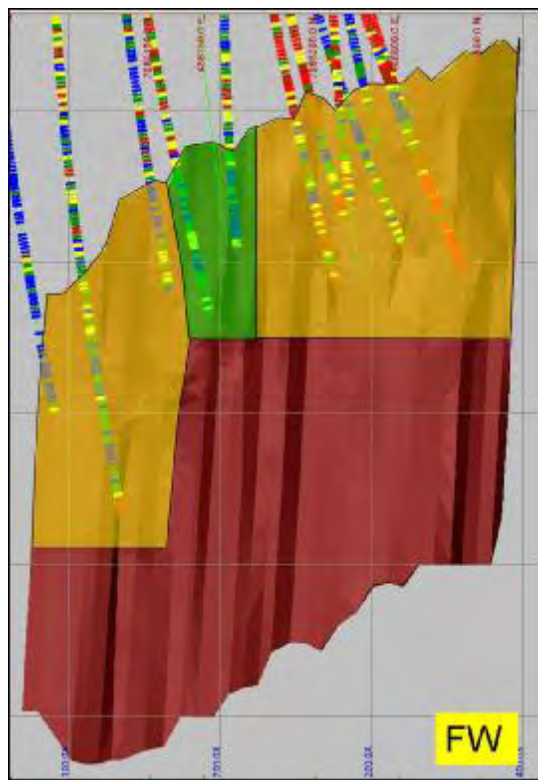
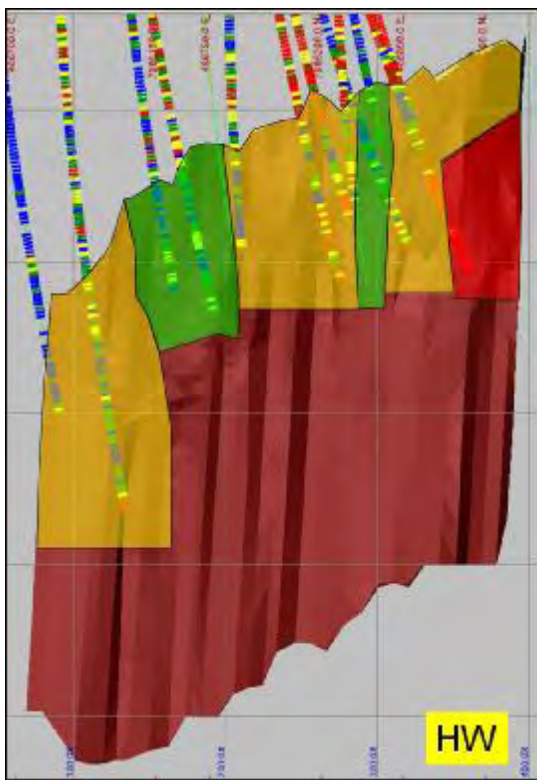

Figure 19.3: Bedding Measurements from Historical UG Mapping at Bellekeno

The results of the geotechnical domain review for the Southwest and East zones are presented as figures 19.4 and 19.5. The rockmass was separated into hanging wall, mineralized zone, and footwall zones, and then domained in terms of ‘poor’, ‘fair’, or ‘good’ rock mass conditions. Areas of the mineralized zone with no drillholes were not assigned domains.

The domains assigned reflect the quality of the rockmass relative to the mining methods proposed. In some areas, the hanging and foot wall rocks immediately adjacent to the mineralized zone (~1 m in most situations) are of lower rockmass quality than generally encountered. Figures 19.5 and 19.6 show examples of the variable HW ground conditions in the East zone. In these areas, the mining of the mineralized zone may result in instability in the hangingwall, resulting in increased dilution. This situation appears to occur in approximately 20% of the drillholes reviewed, and dilution may be significantly more than planned. Similarly, sub-parallel jointing indicated by underground mapping (if common) to the mineralized zone will form wedges which may also create additional unplanned dilution

Several fault and bedding shear structures are anticipated to intersect the Bellekeno mineralized zones and associated development. It is expected that these zones will have an impact on the local ground conditions and may require extra support when intersected.



Legend
■ Poor
■ Fair
■ Good



Bellekeno Project
Geotechnical Assessment

Geotechnical Assessment of Southwest Zone: Domains & Width

PROJECT: 2CA017.000	DATE: June 2008	APPROVED:	FIGURE: 19.4
------------------------	--------------------	-----------	------------------------

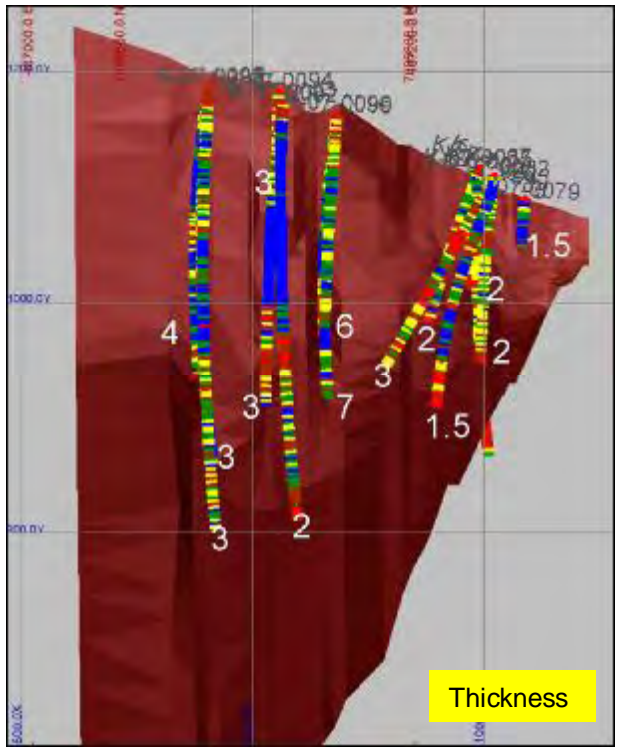
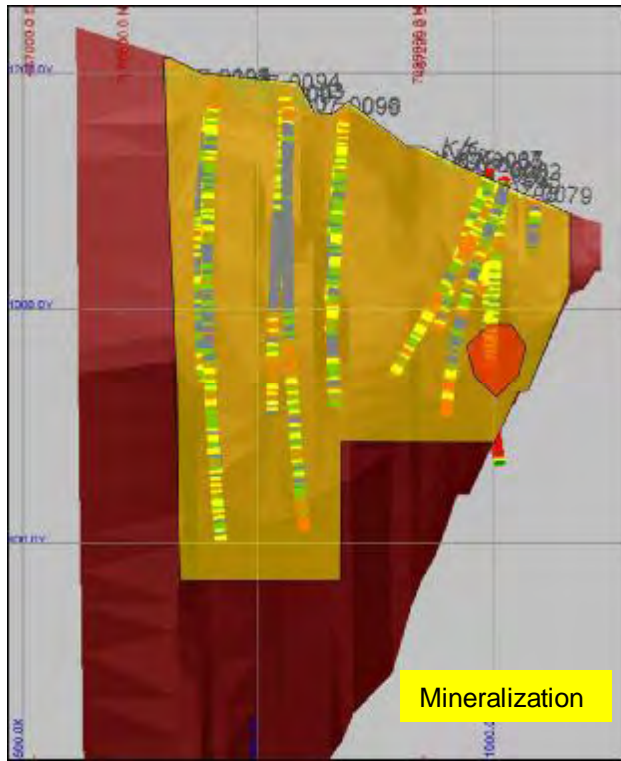
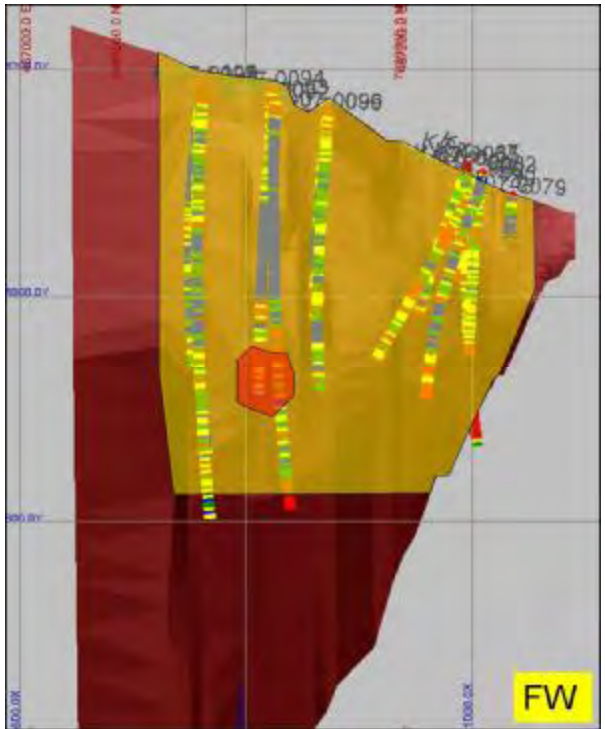
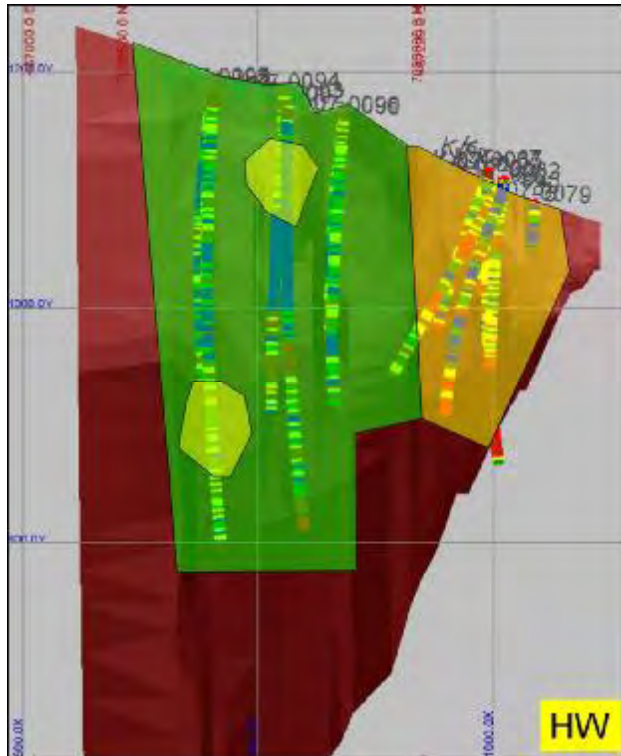

Legend	
■	Poor
■	Fair
■	Good



Bellekeno Project Geotechnical Assessment			
Geotechnical Assessment of East Zone: Domains & Width			
PROJECT: 2CA017.000	DATE: June 2008	APPROVED:	FIGURE: 19.5

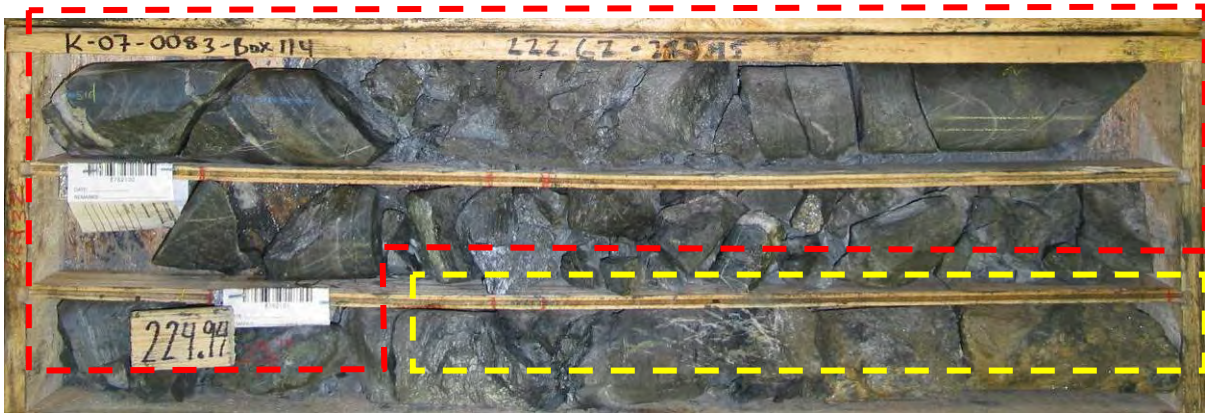

Figure 19.6: K-07-0083 Mineralized Zone (yellow) and Immediate Hangingwall (red) with Poor Ground Conditions



Figure 19.7: K-07-0092 Mineralized Zone (yellow) and Immediate Hangingwall (red) with Good Ground Conditions

19.1.2 Mining Method Selection

Mining method selection for Bellekeno is contingent on the characteristics of the deposit and must take into account, deposit geometry, geology, geotechnical characteristics, hydrogeology, and other variables.

Upon preliminary review of the deposit characteristics, three main mining methods were deemed suitable for different parts of the deposit. These methods consist of cut and fill (“C&F”), shrinkage stoping and longhole (“LH”) stoping for pillar recovery. The actual methods used, and variations of the methods applied, will depend on site specific conditions in each area of the deposit and more data is needed to finalize the selection. A summary of the proposed methods is shown in Table 19.1.

Table 19.1: Mining Method Selection

Selected Mining Methods	Justification
Overhand or Underhand Cut and Fill	Selected for less competent rock, limited dilution and to allow for easier extraction of the remaining pillars
Shrinkage	Selected for the narrow vein sections with reasonably competent rock
Long Hole	Selected to extract the remaining C&F pillars towards the end of the mine life

A brief description of each main mining method is given in the following pages.

Cut and Fill mining is a method of short hole mining used in a wide range of deposit geometries. There are two main methods of cut and fill mining; overhand cut and fill (“OCF”) and underhand cut and fill (“UCF”).

OCF typically uses uncemented fill and mining begins at the bottom of a mining block and advances in “slices” of “lifts” upwards. Stopping begins from an access ramp driven off the main level to the bottom of the mineralized zone to be accessed. Using development mining techniques, a drift is driven through the mineralized zone to the defined limit of mining. Upon completion, the drift (or "cut") is filled with cemented or uncemented back-fill. Once filled, another drift is driven on top of filled cut. This process continues until the top of the stope is reached. See Figure 19.8 for a typical C&F schematic.

UCF mining will be used when the backs and ribs of stopes are deemed not competent enough to economically allow OCF mining. UCF utilizes engineered, cemented backfill with mining beginning at the top of a mining block and advances downwards underneath the competent backfill. Each completed cut is filled with cemented backfill and then mining of the next lower cut proceeds under the cemented backfill once it has cured.

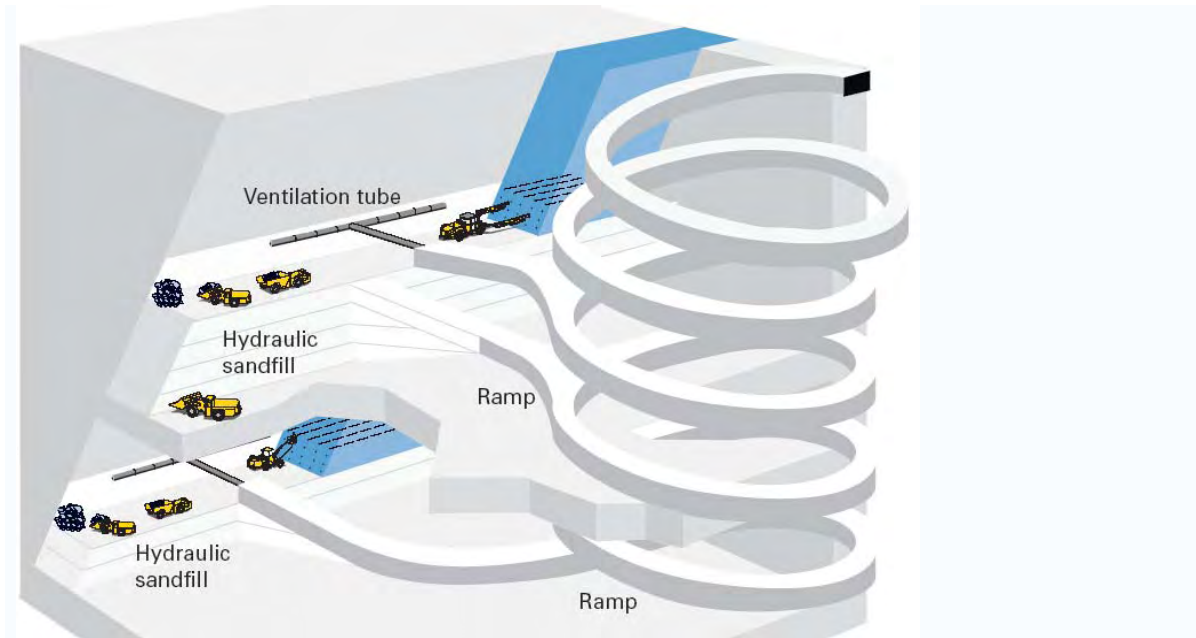

Figure 19.8: Overhand, Mechanized Cut & Fill Mining Method (from Atlas Copco)

Both UCF and OCF will be mechanized where mineralized envelopes are in excess of 2.1 metres wide and stopes can support capitalized development to access multiple lifts. The proposed layout for CF mining will be to use 20 m vertical spacing between sill cuts. Each lift will be approximately 4 m vertical for a total of 5 lifts but will depend on vein thickness.

Long hole stoping (“LH”) is normally used where large blocks of continuous mineralization can be identified and the surrounding rock is reasonably strong (Figure 19.9). Access to the top and bottom of the mineralized block is provided with drifts. A vertical opening (slot raise) is created within the stope block from the top of the block to the bottom. Long holes are drilled to blast vertical slabs off the mineralized block which is then scooped from a lower drawpoint by and LHD.

In the Bellekeno application, LH stoping will be used to recover pillars left behind from previous mining in the 99 zone. The depth on blast holes in the production sequence will be approximately 12-15 metres long. Blind raises or slot raises will be drilled with the LH drill unit, blasted and the stope block will be retreated out by drilling and blasting successive rings. The current plan assumes full to partial fill. Typically LH blocks will be pulled last unless they are in an area that would not conflict with ongoing operations. They could also be filled if they are located too close to mine infrastructure.

Only 2% of the total tonnes from the mine are planned to come from this pillar recovery. Pillar recovery can be a challenging exercise and can lead to excessive dilution and low extraction if ground or fill conditions are poor as is often the case.

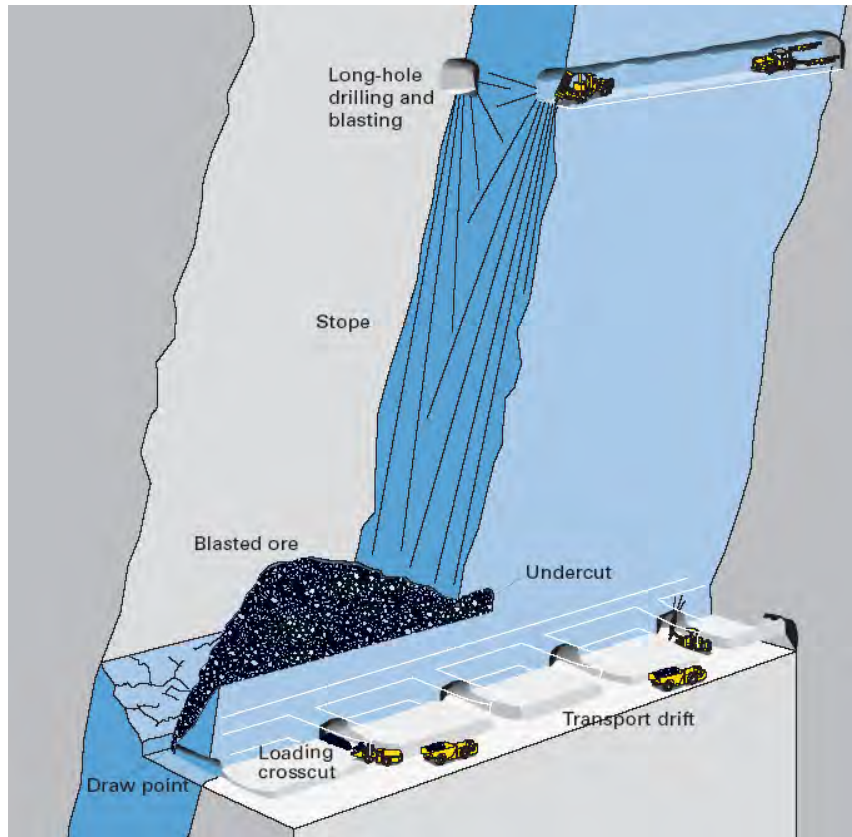

Figure 19.9: Long Hole Mining Method (source: Atlas Copco)

Shrinkage stoping (Figure 19.10) is used mainly in steeply dipping, relatively narrow mineralization with regular boundaries. Mineralized material and waste (both the hanging wall and the footwall) should be competent, and the mineralized rock should not be affected by storage in the stope. It is a flexible mining method that does not require backfill during stoping. Successive horizontal slices of ore, usually about 3 metres high, are taken along the length of a stope, in a manner similar to cut-and-fill. The broken rock is removed from the stope through drawpoints at the bottom horizon spaced about every 7.5 metres along strike. Only the swell after blasting is drawn from the stope to leave enough broken material in place to provide a floor for the next lift.

Shrinkage mining will be done on narrow <2 m wide veins where dilution is a concern. Typically the stope will be supported by an outside scram for mucking, then by a central raise through the zone for ingress-egress and ventilation. During the mining sequence approximately 40% of the rock will be mucked as swell. Stopes may be left open after draw down or the void utilized for waste deposition. An alternative to shrinkage is a modified shrinkage/conventional C & F scenario utilizing fill and mechanized access. Lifts are accessed via rubber tired equipment to the vein intersection. Once the vein is exposed conventional mining of the stopes will be done utilizing jacklegs, stopers and slushers. Broken muck is then slushed to the stope access where a scoop completes the mucking cycle. Stopes could be filled prior to taking the next lift with either paste or hydraulic fill.

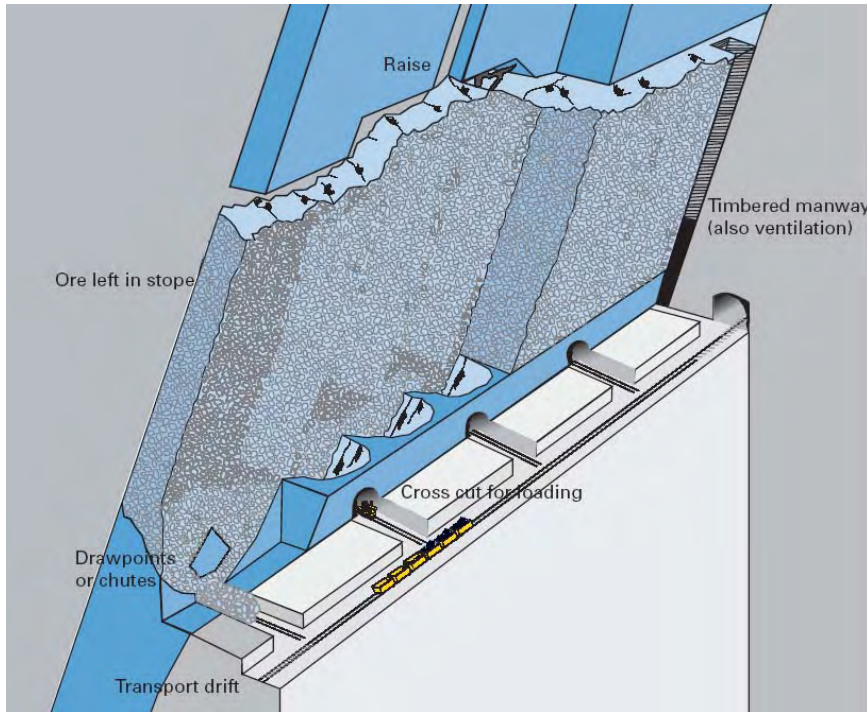

Figure 19.10: Shrinkage Mining Method (source: Atlas Copco)

19.1.3 Mine Access

Access to underground mine will be accomplished via the new Bellekeno East decline driven at a grade of approximately -12.5%. (Figure 19.11) The main decline will intersect the Bellekeno historical ramp at the 625 level. From this intersection of this ramp, the historical ramp will be accessed (99 and SW zones) and rehabilitated. To the north a new exploration ramp will be developed and extended contingent on depth definition of the East Ore. Secondary access will initially be to the north through the rehabilitated Bellekeno 625 level track drift.

Main development headings and associated cross-section dimensions are provided below.

- East Main New Decline 4.6 m W x 4.6 m H.
- Historical Ramp 4.0 m W x 4.0 m H.
- Ore Access 4.0 m W x 4.0 m H
- Track Drift 2.7 m W x 2.7 m H
- Misc. Development 5.0 m W x 4.0 m H includes sumps, re-muck bays, substations, truck loop, LHD access, explosive magazine, etc.).

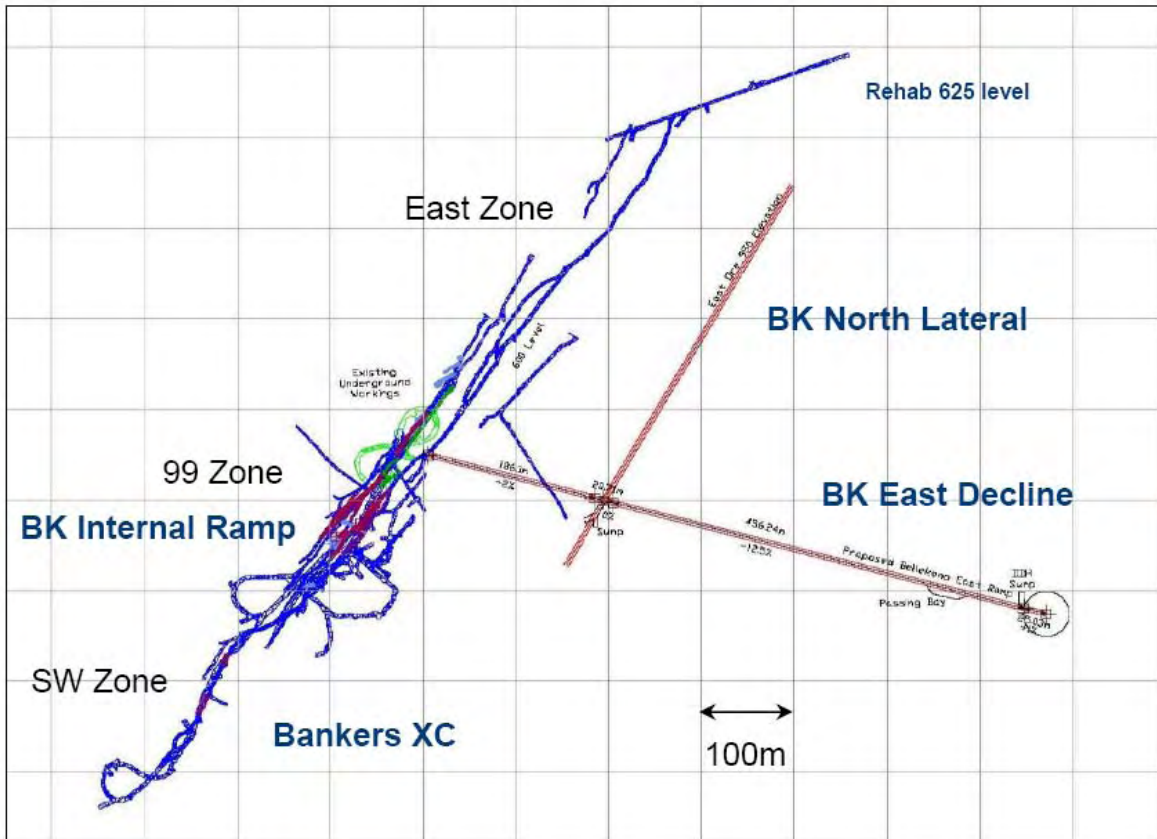

Figure 19.11: Proposed Bellekeno East Decline

Development Ground Control

Decline Characterization

Detailed in Figure 19.12 is a wedge failure diagram constructed using a photo taken at the Dixie Mine portal. Wedge failure modes are depicted forming along inter-banded graphitic schist units, inter-banded quartzite units and steeply dipping joints. The shallow bedding dip is also evident in the Bellekeno 625 drive as depicted in Figure 19.11. The drift photo shows inter-banded quartzites and graphitic schist in the Middle Quartzite, with L1 bands in red and joints in green.

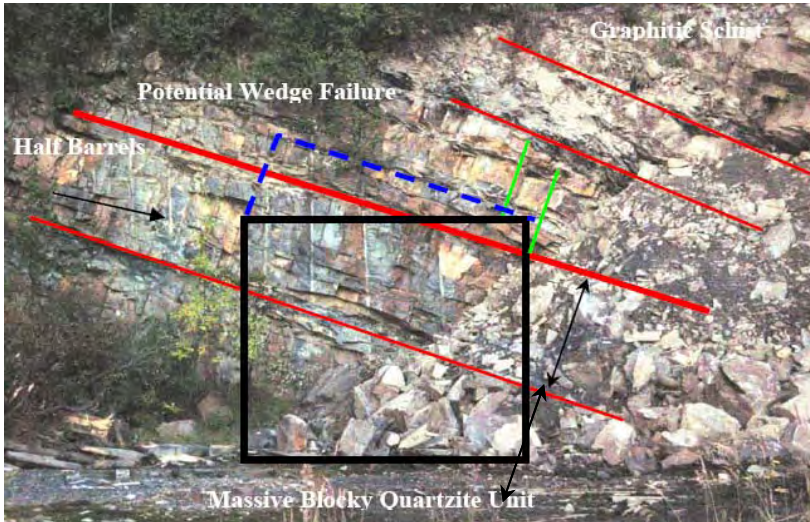

Figure 19.12: Wedge Failure Diagram in the Middle Quartzite Unit

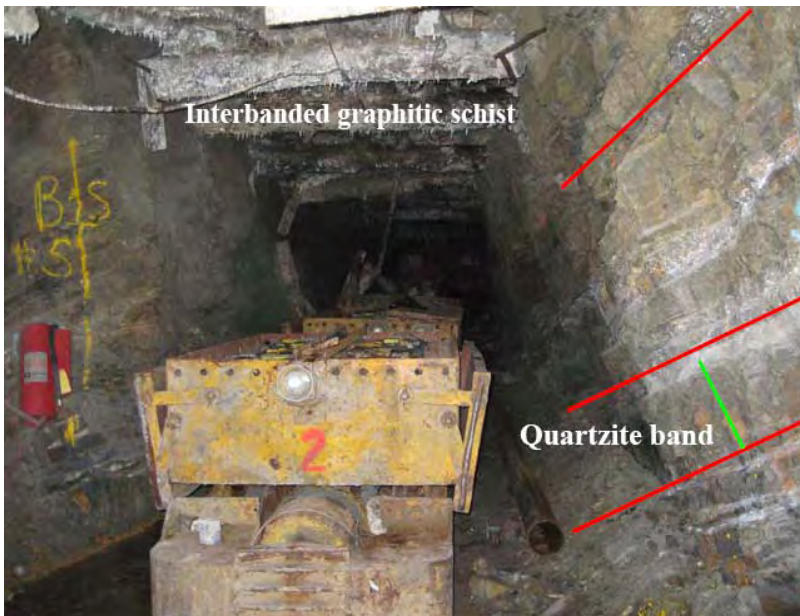

Figure 19.13: Bellekeno 625 Level Charging Station

Support Recommendations – Development

The decline and mine headings are considered to be permanent manway excavations and are planned to be in operation for a several years. Support for this type of access is generally designed to be of a higher quality with a longer life span than for short term openings or non-man access openings. Split sets/friction anchors, as a result of the risk of corrosion and lower performance capabilities, are not recommended as the primary support method in long term openings.

In general, SRK recommends that support be installed to within 1 m of the face. This is especially important when excavating in poor ground conditions, and where bedding and joint sets form wedges as previously depicted.

All pattern and spot bolts should be installed with 6" square ¼" thick domed bearing plates with domed nuts.

Mine Development Headings

The planned mine development headings are 4.6 m wide x 4.6 m high to accommodate mobile equipment and the selected ventilation tubing. Based on historic development and mining practices at Bellekeno, SRK recommends that the development headings are sized, where possible, to the minimum dimensions possible to facilitate self-support and reduce the need for heavy additional passive support.

Three types of support are recommended to control the anticipated ground conditions in the HW and FW rockmass. Appendix C contains schematics of the support types described below.

Type 1 Support: 9 x 2.4 m long 19 mm (#7) diameter resin-grouted rebar installed on a 1.2 m inter-ring and 1.5 m intra-ring bolt spacing. #6 welded wire mesh (0.1m square) to be installed across the back and walls to 2.3 m above floor.

Type 2 Support: 11 x 2.4 m long 19 mm (#7) diameter resin-grouted rebar installed on a 1.2 m inter-ring and 1.5 m intra-ring bolt spacing. #6 welded wire mesh to be installed across the back and walls to floor level.

Type 3 Support: 15 x 2.4 m long 19 mm (#7) diameter resin-grouted rebar installed on a 1.0 m inter-ring and 1.2 m intra-ring bolt spacing. #6 welded wire mesh to be installed across back and walls to floor level. A 25 mm flash-coat of shotcrete to be applied to the back and walls immediately following blast, with an additional 25 – 50 mm of shotcrete to be applied following support installation.

Drift Intersections - Normal Ground Conditions: Where two or more headings are planned to intersect, it is recommended that 3.0 m long resin-grouted rebar should be installed in the area of the intersection during the advance. #6 welded wire mesh should be installed according to the support requirements described previously.

In poor ground conditions, the mining sequence will become critical to the overall stability of the development.

Drift Intersections - Poor Ground Conditions: Ideally, drift crosscuts will not be located when coming into, or near shear zones or other zones of poor ground quality. Should intersections be required in areas of poor ground, pre- and post-breakaway support will be installed.

19.1.4 Stopping

Stope Design (Stability Graph Method)

The Stability Graph Method for Open-Stope Design was used to calculate the design span of the long-hole open-stopes in each orebody. This method requires the use of the NGI modified tunnelling quality index (Q') to calculate the stability index (N') where:

$$N' = Q' \times A \times B \times C$$

A = stress factor

B = joint orientation factor

C = gravity factor

Using the calculated N' values, the Potvin stability graph (1998) was used to provide the stable situation hydraulic radius (HR). The HR was then used in calculating the maximum stope span using the design stope heights. For further details regarding the Potvin stability graph, the reader should refer to the “*Stability Graph Method for Open-Stope Design*”.

Stope lengths for design vertical stope heights of 12 meters (for longhole) were calculated for each domain in each orebody. Figures 19.14 and 19.15 provide details and design recommendations for the stopes at the Bellekeno project. The Q support chart (Grimstead and Barton, 1993) is also presented as a guideline for support in open areas.

In the wider areas of the mineralization zone, the spans in this design have been limited in width due to the possibility of shears within the spans and at the contacts. On-dip stope heights (in brackets) are used in the calculations.

Pillar Sizes

Design recommendations for the various pillars between levels and stopes are based on orebody thickness and are noted below. Rib pillars and crown pillars have been designed to accommodate the potential for poor ground as indicated by current exploration drilling, and pillars placed in these areas may have stability issues.

Rib pillars should be 1:1 ratio provided that fill is used and crown and closure pillar areas should be 1.5 – 2.0 times the mineralization width depending on the ground conditions.

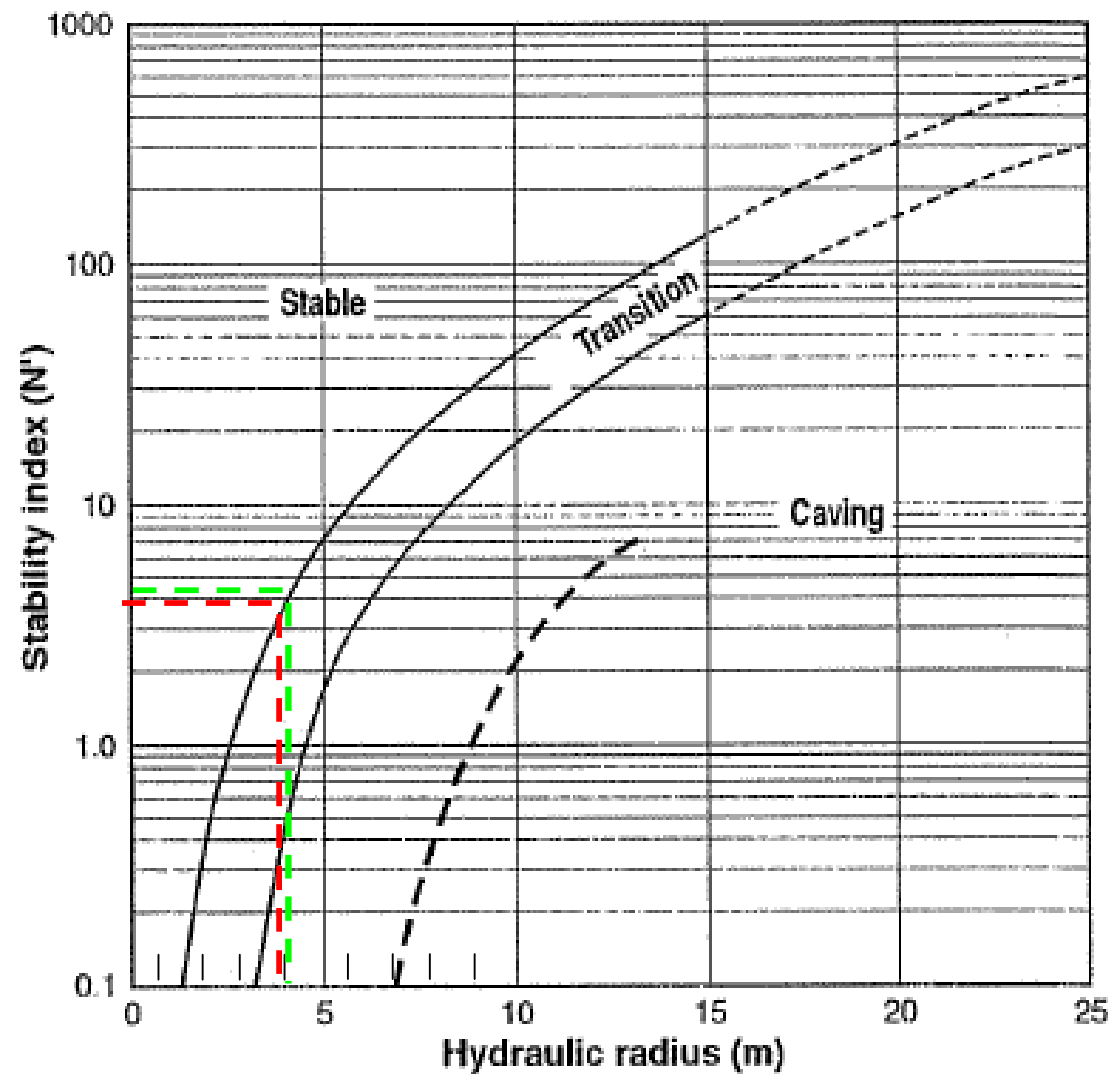

Potvin and Hadjigeorgiou (1998)

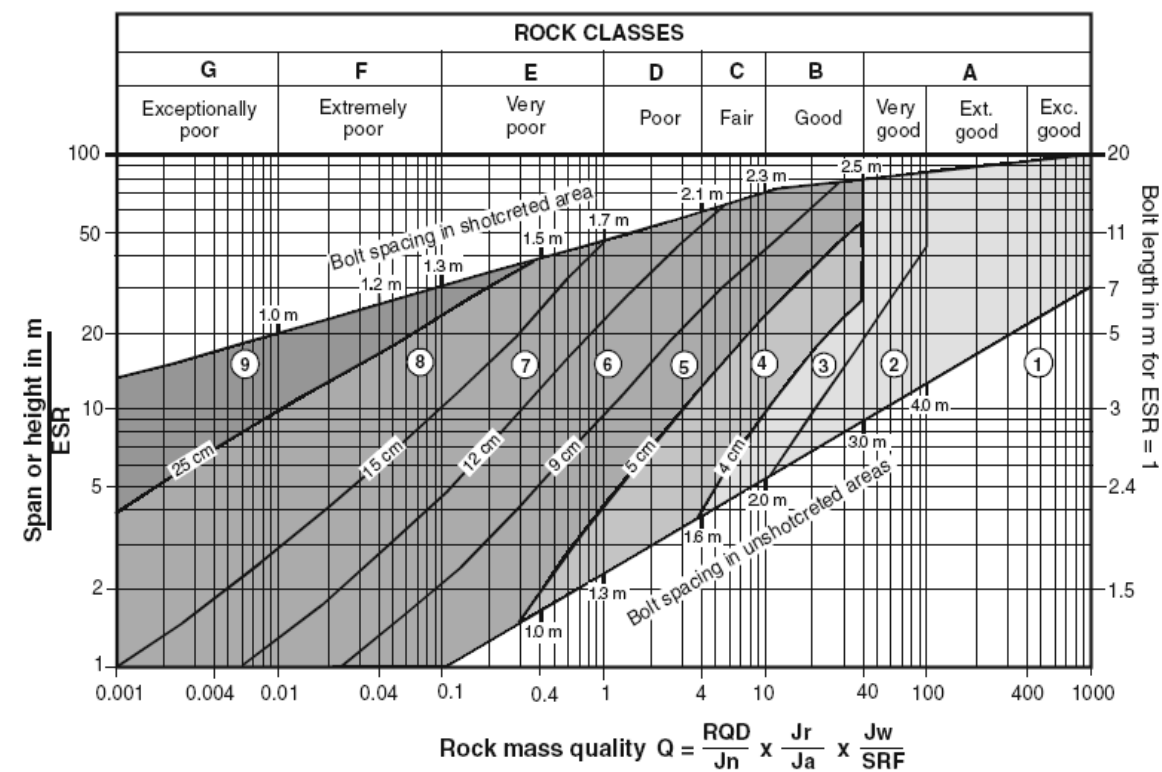
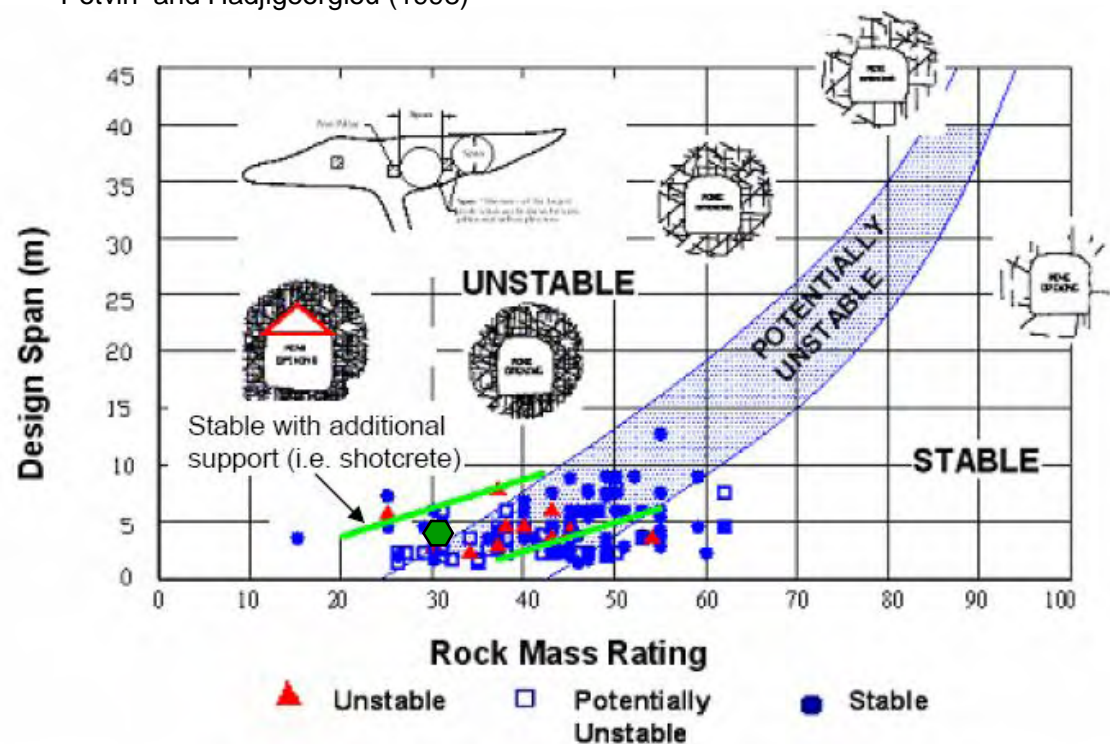

$$\text{Rock mass quality } Q = \frac{RQD}{J_n} \times \frac{J_r}{J_a} \times \frac{J_w}{SRF}$$

REINFORCEMENT CATEGORIES:

- 1) Unsupported
- 2) Spot bolting
- 3) Systematic bolting
- 4) Systematic bolting, (and unreinforced shotcrete, 4 - 10 cm)
- 5) Fibre reinforced shotcrete and bolting, 5 - 9 cm
- 6) Fibre reinforced shotcrete and bolting, 9 - 12 cm
- 7) Fibre reinforced shotcrete and bolting, 12 - 15 cm
- 8) Fibre reinforced shotcrete, > 15 cm, reinforced ribs of shotcrete and bolting
- 9) Cast concrete lining

Area	Zone	Q'		N'		N' Plot	HR
		Lower	Upper	Lower	Upper		
SW	HW	2.65	3.46	3.71	4.84	4.1	4.2
	MIN	0.93	1.8				
	FW	1.13	3.55	1.582	4.97	3.9	3.9

Area	Zone	Stope Height (1)	Stope Height (2)	Stope Height (3)	Span (1)	Span (2)	Span (3)	RMR Plot	Graphical Span Man Entry	Recommended Span Max. (m)
SW	HW	12.4	18.6	24.8	26.0	15.3	12.7			
	MIN	-	-	-	-	-	-	28 - 34	4	3
	FW	12.4	18.6	24.8	21.0	13.4	11.4			

Notes:

- All distances given in Meters



Bellekeno Project
Geotechnical Evaluation

Span and Support Evaluations
Based on the Q-System: SW Zone

PROJECT: 2CA017.000	DATE: June 2008	APPROVED:	FIGURE: 19.14
------------------------	--------------------	-----------	------------------

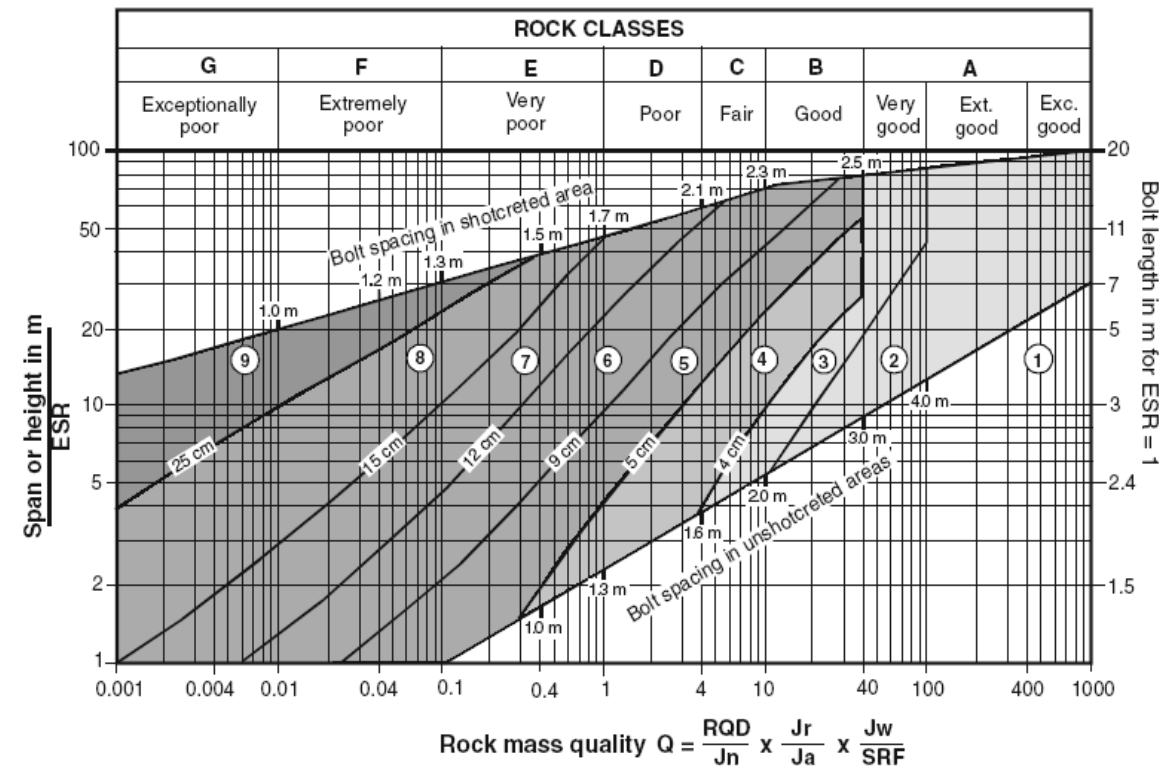
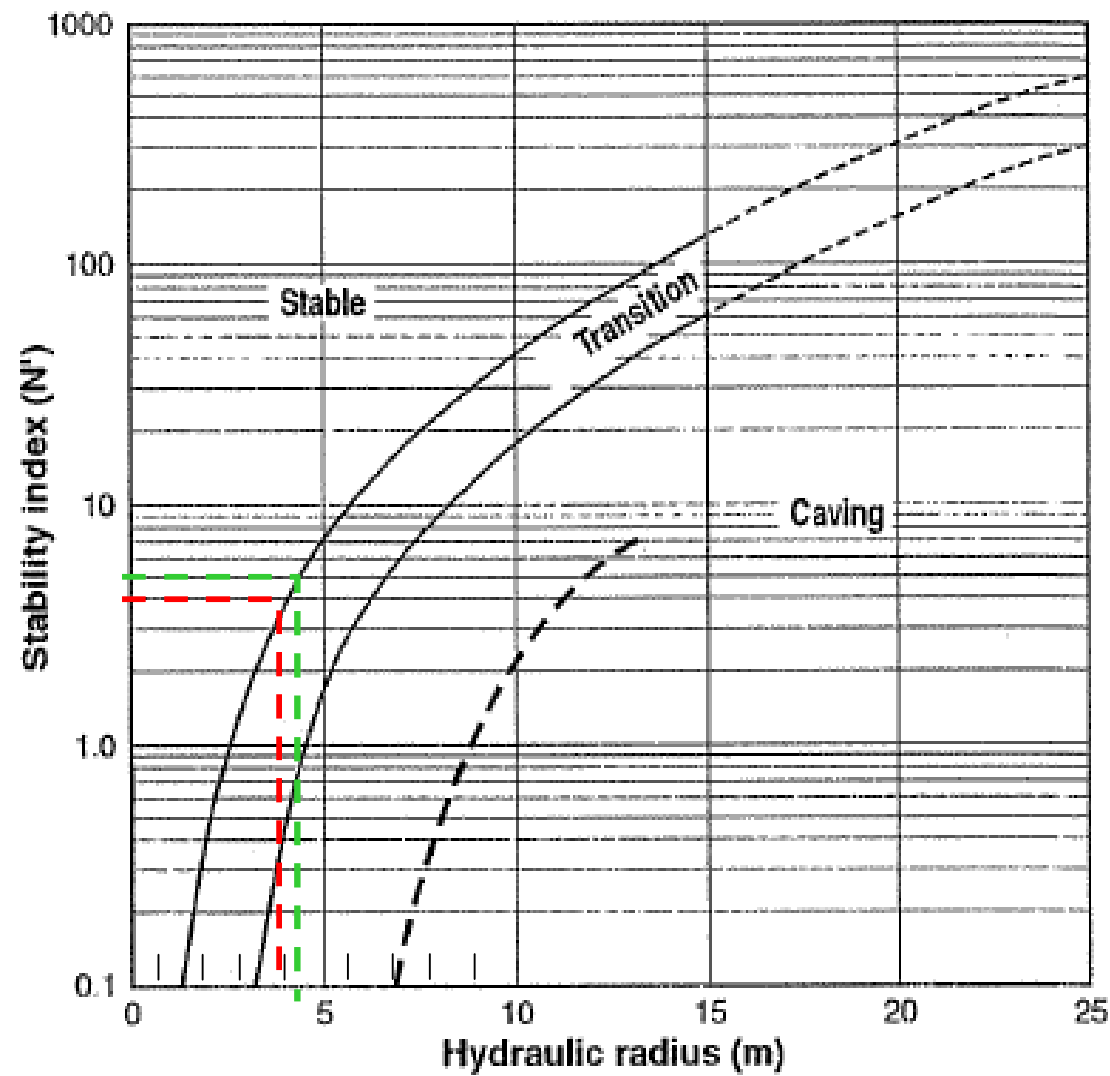

$$\text{Rock mass quality } Q = \frac{RQD}{J_n} \times \frac{J_r}{J_a} \times \frac{J_w}{SRF}$$

REINFORCEMENT CATEGORIES:

- 1) Unsupported
- 2) Spot bolting
- 3) Systematic bolting
- 4) Systematic bolting, (and unreinforced shotcrete, 4 - 10 cm)
- 5) Fibre reinforced shotcrete and bolting, 5 - 9 cm
- 6) Fibre reinforced shotcrete and bolting, 9 - 12 cm
- 7) Fibre reinforced shotcrete and bolting, 12 - 15 cm
- 8) Fibre reinforced shotcrete, > 15 cm, reinforced ribs of shotcrete and bolting
- 9) Cast concrete lining

Potvin and Hadjigeorgiou (1998)

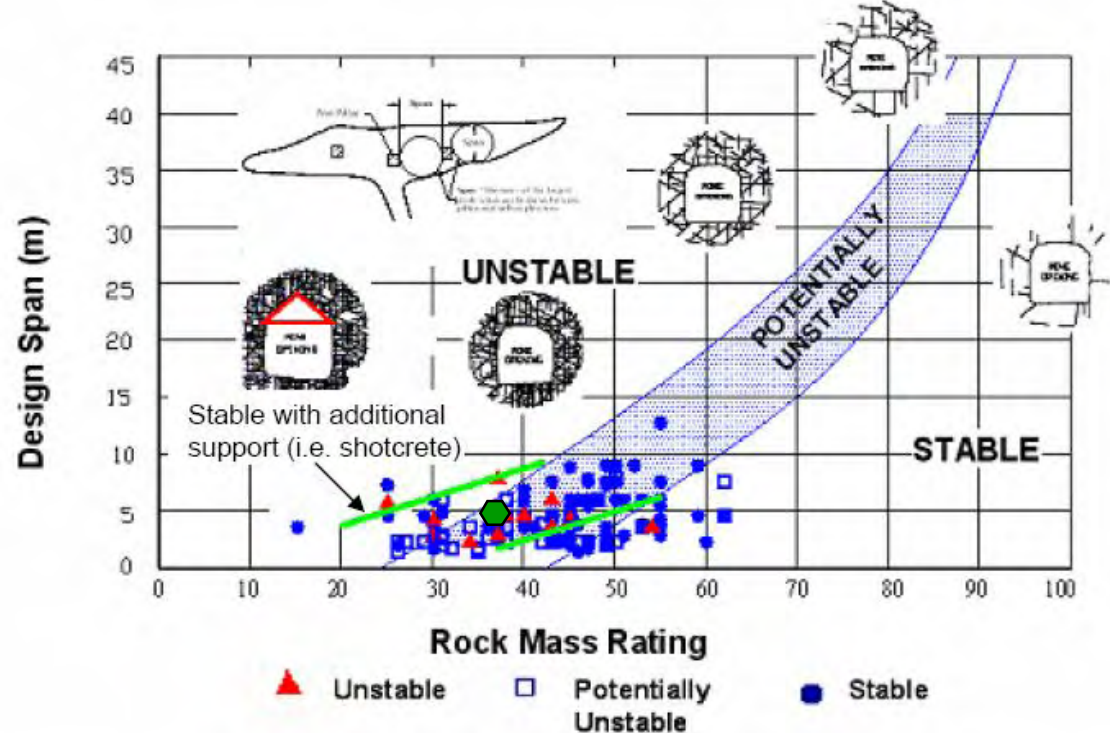

Area	Zone	Q'		N'		N' Plot	HR
		Lower	Upper	Lower	Upper		
EAST	HW	3.5	4.42	4.9	6.188	5	4.4
	MIN	2.33	3.83				
	FW	1.3	3.49	1.82	4.886	3.8	3.9

Area	Zone	Stope Height (1)	Stope Height (2)	Stope Height (3)	Span (1)	Span (2)	Span (3)	RMR Plot	Graphical Span Man Entry	Recommended Span Max. (m)
EAST	HW	12.4	18.6	24.8	30.3	16.7	13.6			
	MIN	-	-	-	-	-	-	30 - 38	5.5	4.5
	FW	12.4	18.6	24.8	21.0	13.4	11.4			

Notes:

- 1. All distances given in Meters



Bellekeno Project
Geotechnical Evaluation

**Span and Support Evaluations
Based on the Q-System: East Zone**

PROJECT: 2CA017.000	DATE: June 2008	APPROVED:	FIGURE: 19.16
------------------------	--------------------	-----------	------------------

Support Recommendations – Production Areas

Historically, ground conditions were considered poor with extensive use of timber being required in production areas. Typical stopes utilized square set timbering in wide sections of vein and stulls in shrink stopes. The square sets were pre-cut to 1.8 m squares so production was restricted to 1.8 m rounds. Use of square sets did not allow the vein hanging wall to be tightly contoured which resulted in undercutting that contributed to hanging wall failures.

A compounding factor was the occurrence of fairly large quantities of water along many of the veins. The presence of water in production areas acted as a lubricant, exacerbating ground problems.

Support for the development in-stopes is based on the Grimstead and Barton Q support chart (1993). Using Q-values developed for the Bellekeno project, it is recommended that support in-stope should be as follows:

Orebody (SW): Grouted rebar or Swellex (dependent on ground conditions) on a 1.2 m x 1.2 m spacing with wire mesh screen and shotcrete. Length of rebar will vary from 1.8 m – 2.4 m depending on the excavation span.

Orebody (EAST): Grouted rebar or Swellex (dependent on ground conditions) on a 1.2 m x 1.5 m (ring) spacing with wire mesh screen and shotcrete if required. Length of rebar will vary from 1.8 m – 2.4 m depending on the excavation span.

The use of friction anchors in can be further investigated during trial mining.

19.1.5 Drilling

A minimum of 2 jumbos will be necessary to meet production targets. One jumbo will be dedicated to development of new ramps and accesses and the second jumbo will be dedicated to drilling in the cut and fill stopes. A third, smaller, micro jumbo will be used in small headings and as a back-up for when a jumbo is broken down.

For the relatively small tonnage of LH stopes (16,000 t planned), the contracting of a drill and skilled operator will be considered. Sill development and mined slot raises can be completed in advance of the LH drilling to minimize the contract cost.

19.1.6 Blasting

Due to the weak nature of the mineralized rock, a powder factor of 0.25 kg/t for shrinkage or CF mining was assumed. The LH method would use up to 0.4 kg per broken tonne. These factors must be verified with trial mining. The blasting product will be ANFO and augmented with stick powder where needed. Detonators will be non-electric and tied in with detonator cord. Powder and cap magazines will be located on surface and proximal to the Bellekeno East portal. Explosives and detonators will be conveyed to the working headings on as need basis in transported via approved

day boxes. Excess explosives will be returned to the magazine at the end of the shift. A log book will be maintained in the magazine as required by YT OH&S.

19.1.7 Mucking

One 4.6 m³ LHD and two 2.5 m³ LHDs will be able to meet production targets. The 4.6 m³ LHD will be used for primary development as well as fill placement. One 2.5 m³ LHD will be dedicated to production from the stopes and fill placement. The second 2.5 m³ LHD will be used for mineralized and waste rock mucking and fill placement when the other LHDs are unavailable. A 1 m³ LHD will be used where mechanized mucking in narrow veins is needed.

19.1.8 Grade Control

Grade control will be absolutely critical to the success of the Bellekeno operation and will be done as described in the waste rock management plan. Mineralized and waste contours will be painted on the face and random chip samples taken within the various mineralized and waste units. A digital photo will be taken of the face and digitized in AutoCAD. Tonnes will be calculated from the square metre face area and assigned a predetermined bulk density and round length. Assays will be processed on site in the lab. Daily assay sheets along with geologist's directives will be posted daily. The onsite assay lab will assay for Ag, Au, Pb, Zn and Fe. It is anticipated that the lab will be capable of 12 hr rush turnover on a dozen samples. A QA/QC program will be in place to ensure quality control.

19.1.9 Backfill

For the purpose of the scoping study, a detailed ground control management plan has not been established for stoping methods. A detailed plan will be included in the next level of study. However, it is anticipated that ground control in the stopes will be critical based on historic observations and data. Keno Hill is renowned for poor ground and it is anticipated that a combination of CF mining methods, screen, shotcrete and split bolts will key in holding ground and mine backfill.

There are several alternatives available for mine backfill at Bellekeno including:

- Hydraulic backfill;
- Paste backfill;
- Waste backfill – Cemented Rock Fill (CRF);
- Conventional cemented dry fill.

The only fill method actually used historically at Bellekeno was cemented run of mine waste placed with mechanized equipment and levelled with a blowpipe and packer. Fill from surface can be hauled on the return trips of both mill feed and waste hauls. Waste when not used to fill the mine voids will be hauled to surface by 20 t trucks and placed into the waste storage.

Hydraulic Fill (HF)

This is the least favoured type of fill because of the requirement of decanting, collecting and pumping of water. There is, however, an existing mobile hydraulic fill plant on the property. In its current configuration it is not underground compatible. It may be possible to reconfigure the plant for underground use or convert it to a paste or CRF plant. The best use of the existing plant would be as a delivery mechanism of historical tails into mined out voids within any number of abandoned mines in the district. An assessment would have to be made as to what future resources might be compromised by hydraulic fill.

Paste Fill (PF)

Delivery of PF is proposed utilizing a small portable pump and mixer set up in the stope access ramp, fed by either a truck or scoop. It is envisioned that the portable plant will be capable of pumping 18 to 36 tonnes (20 to 40 tons) per hour. In-stope delivery will be via HDPE pipe or equivalent pressure rated pipe. In parallel to the HDPE delivery pipe, a 50mm (2 in) HDPE breather pipe will be installed to ensure tight fill. Waste rock barricades or timbered barricades would be constructed in the stope access ramp to contain the fill. PF could be placed in sequence: potentially a 1-1.5m floor could be poured with 6% cement and allowed to cure then the remainder of the stope could be poured with 2-3% cement for hydration and wall rock stability.

Cemented Rock Fill (CRF)

As an alternative to PF, cemented rock fill (CRF) might be used. Delivery would be via rubber tired equipment from a plant located either underground or on surface. This is a relatively simple method and the aggregate (possibly dry, coarse tailings) material is readily available nearby. Stope delivery would be via small scoops or trucks and then ram-fill the stope. CRF would be applicable to mechanized stopes that can be accessed with rubber tire equipment; it would not be applicable to narrow stopes unless it could be levelled and compacted.

Detailed studies will be required to determine the most efficient method of future backfill placement at Bellekeno. Multiple types or combinations of fill methods may to be employed. It is anticipated that the preferred mining method for SW, 99 and East zones will be underhand cut and fill which would necessitate higher cement content (>6%).

Operating Cost Estimates for Various Fill

An operating cost per tonne has been estimated at CA\$10/tonne and not differentiated between fill types.

19.1.10 Development and Development Schedule

Ramp Development (Primary)

In order to sustain six production faces, ramp development rates must achieve 15 metres per month or 180 metres per year, resulting in 20 metres of vertical height. This does not include crosscut or mineralized zone access. Typically, a minimum standoff from the vein of 45 metres is required to repeatedly breast down and alter the access for the next lift (secondary development). Therefore 645 m/yr or 55 m/month must be sustained in accesses.

Ore Access Development (Secondary Development)

As previously stated, a new block needs to be accessed approximately every 50 days. Each block will sustain two faces, therefore, in the replacement scenario approximately eight (breast downs) of the access need to be achieved each year. Each access is approximately 50 m in length at various grades. A total of 400 m/yr or 33 m/mo will be necessary to sustain the planned rate of production.

Raise Development

Shrinkage stopes require a raise for ingress/egress and ventilation. Currently Bellekeno has levels every 33 m. At a replacement or augment ratio of 3 shrinkage stopes to one CF stope, three shrink stopes will have to be placed in production at start-up. Thus three 33 m raises need to be driven during the pre-production stage. On a sustained basis, the average block size for a shrink stope will be 1,089 tonnes, with a block being mined every 60 days. Therefore six, 33 m raises need to be driven each year for a total of 200 metres per year or 17 m/mo of raise development. Some refinement to this scenario will be made once a block model is complete as blocks may be strung together resulting in increased tons per meter of raise development.

Development Schedule

Table 19.2 indicates the timing for the different phases of the development to sustain the yearly tonnage requirement of 81,531 tonnes. The schedule takes into consideration the ramp up time necessary to achieve sustainable monthly advances.

Table 19.2: Development Schedule

	Units	Year						Total
		-1	1	2	3	4	5	
East Decline	m	150	150	-	300	-	-	600
Ramp Development & O/A	m	400	428	828	828	828	828	4,140
Exploration Development	m	330	340	670	670	-	-	2,010
Ore Access (Secondary)	m	200	200	400	400	400	400	2,000
Raises	m	50	50	200	200	200	200	900
Total Development	m	1,130	1,168	2,098	2,398	1,428	1,428	9,650

19.1.11 Production Rate and Schedule

Production Rates

LH stopes make up 2% of the mine production and will be extracted late in the mine plan. Shrinkage stopes represent 20% of the mined tonnes and will be mined concurrently with CF stopes, which make up 78% of the production base.

Based on average round sizes for each mining method, in order to sustain 250 tonnes per day an average of 2.5 rounds in cut and fill need to be mined each day and supplemented, at times, with shrinkage material. Assuming an average of 100 tonnes per round for CF mining, 4 to 6 CF production faces will be required to sustain production. This assumes that 2 to 3 CF rounds will be blasted each day with 2 to 3 ends unproductive due to grade control, bolting, survey, ground conditions, modeling variability, equipment availability, manpower etc.

In order to sustain six faces of CF ore, six other faces will be in the fill cycle and another six faces will be in access development. This requirement will be partially offset by buffering with shrinkage mining tonnes. An average breast round in a shrinkage stope will be approximately 30 tonnes of which approximately 12 tonnes will be available immediately to be mucked as swell. The material remaining in the stope will be mucked at the stope's completion and will provide a inventory of broken muck.

Detailed scheduling of stopes was not conducted and will be done at the next level of study.

Production Schedule

The first stage of the project will consist of driving the East decline and rehabilitating the 625 level with dedicated crew and equipment. When the rehabilitation on the 625 level is finished, this crew will begin developing raises, ramps and access drifts required to start production.

The second stage will begin once the East Decline is completed and larger equipment can access the 625 level. The second stage will start production from the CF and shrinkage stopes which will be mined will be mined at constant rates until well into the Q3 of the forth year, when long hole stopes mining will commence. These stopes are left until near the end of the planned mine life as they form pillars around the 99 raise.

For the first two years, only 99 and southwest zones will be mined at the rate of 250 t/day. In year three, an additional 150 t/d will be mined from the East until the end of the mining activity. Table 19.3 shows the estimated tonnes mined by each mining method while Table 19.4 indicates the scheduled tonnes by the particular mining zones.

Table 19.3: Production Schedule by Mining Method

Mining Method	Units	Year					Total	
		-1	1	2	3	4		5
Cut & Fill	t		73,000	73,000	117,000	117,000	101,000	481,000
Shrinkage	t		18,000	18,000	29,000	29,000	28,000	122,000
Long Hole	t		-	-	-	-	10,000	10,000
Total/year	t		91,000	91,000	146,000	146,000	140,000	613,000

Table 19.4: Production Schedule by Zones and Grade

Source	Unit	Year					Total Tonnes
		1	2	3	4	5	
SW and 99 Zone production	t	91,000	91,000	91,000	91,000	44,000	408,000
Zn grade	%	4.9%	4.9%	4.9%	4.9%	4.9%	4.9%
Pb grade	%	16.6%	16.6%	16.6%	16.6%	16.6%	16.6%
Gold grade	g/t	0.22	0.22	0.22	0.22	0.22	0.22
Silver grade	g/t	1,221	1,221	1,221	1,221	1,221	1,221
East Zone production	t	0	0	54,750	54,750	95,700	205,000
Zn grade	%	19%	19%	19%	19%	19%	19.0%
Pb grade	%	1.8%	1.8%	1.8%	1.8%	1.8%	1.8%
Gold grade	g/t	0.55	0.55	0.55	0.55	0.55	0.55
Silver grade	g/t	231	231	231	231	231	231
Total Mine production	t	91,000	91,000	145,750	145,750	139,700	613,000
Zinc mill head grade	%	4.9%	4.9%	10.2%	10.2%	14.6%	9.6%
Lead mill head grade	%	16.6%	16.6%	11.0%	11.0%	6.5%	11.7%
Gold mill head grade	g/t	0.22	0.22	0.34	0.34	0.45	0.33
Silver mill head grade	g/t	1,221	1,221	849	849	543	890

19.1.12 Equipment Requirement and Schedule

The estimated equipment requirements for the mine, by year, are shown in Table 19.5.

Ramp Service

The East Decline will be the primary haulage for all material out of and into the mine. It will be maintained to a level that will minimize the strain on operators and the wear on tires and equipment. Although an LHD can be used for grading the ramp, a small grader would be best suited for this job and would prevent production requirements from taking precedence over ramp maintenance. If water is expected in the declines and drifts then a ditches will be maintained to prevent washouts on the ramps and reduce tire damage from wet conditions.

Personnel Transport

Light service underground vehicles will be required to transport employees within the mine. Tractors converted to underground standards will be used to transport personnel and heavy equipment. Lighter vehicles such as Kubota RTVs will also be used for the transportation of personal and light equipment.

Three tractors in total will be used and allocated to electricians, mechanics, and supervisors.

An RTV will be available for the mine survey/geology/engineering. Two other RTVs will be available for management and longhole drilling crews

Table 19.5: Equipment Requirements (No. of units)

Equipment	Year				Total Item
	-1	1	2	3	
2-Boom Jumbo Drill	1	-	-	-	1
1x- single Boom Jumbo	1	-	1	-	2
3.5 m ³ LHD	1	-	1	-	2
2.0 m ³ LHD	1	-	1	-	2
0.75 m ³ LHD	1	-	-	-	1
20 – Tonne Truck	1	-	1	-	2
10 - Tonne Truck	1	-	1	-	2
Diesel electric Jumbo	1	-	-	-	1
Long Hole Bench Drill	-	-	-	1	1
Bolter	1	-	-	-	1
Scissor Lift	1	-	-	-	1
Flat bed Crane Truck	1	-	-	-	1
Service Truck	1	-	-	-	1
U/G Tractors	1	2	2	1	6
Small Dozer (D4)	-	1	-	-	1
U/G Grader	1	-	-	-	1
Utility Vehicle	1	-	-	-	1
Communication System	1	-	-	-	1
Shotcrete System	1	-	-	-	1
Personal Carriers	-	1	-	-	1

Labour Requirements

Table 19.6 outlines the underground workers required to staff a single shift with the equipment outlined in Section 19.1.14. A minimum of three crews are required if a 4 weeks in, 2 weeks out rotation is used.

In addition there will be up to 24 people associated with managerial and technical duties for the mining operation as indicated in the Table 19.7.

Table 19.6: Labour Requirements

Department/Job	Year						
	-1	1	2	3	4	5	6
Development							
Development Crew including Stope Accesses		9	9	9	9	9	9
Longhole Drill & Blast Crew		-	-	-	-	-	-
Waste Truck Drivers		-	-	-	-	-	-
Construction Crew		3	3	3	3	3	3
Subtotal Labour – Development		12	12	12	12	12	12
Backfill							
Stope Prep Crew		3	3	4	4	4	3
Pump Crew		3	3	3	3	3	3
Subtotal Labour – Backfill		6	6	7	7	7	6
Production							
Stope Crew		9	12	12	12	12	9
Scram Level Loader Operators		-	-	-	-	-	-
Haulage Level Loader Operators		-	-	-	-	-	-
Ore / Waste Truck Drivers		3	3	3	3	3	3
Service Crew		3	3	3	3	3	3
Subtotal Labour – Production		15	18	18	18	18	15
Maintenance							
Fixed Plant Mechanics		3	3	3	3	3	3
Mobile Mechanics		6	6	6	6	6	6
Electricians & Instrumentations		3	3	3	3	3	3
Subtotal Labour – Maintenance		12	12	12	12	12	12
TOTAL LABOUR		42	45	45	45	45	42

Table 19.7: Management and Technical Staff

Department/Job	Year						
	-1	1	2	3	4	5	6
Mine Management							
Mine Manager	1	1	1	1	1	1	1
Mine Tech / Recorder		1	1	1	1	1	1
Mine Superintendent - Production		1	1	1	1	1	1
Mine Shift Supervisors		3	3	3	3	3	3
Safety and Training Superintendent	1	1	1	2	1	1	1
Maintenance Management							
Maintenance Superintendent / Foreman		1	1	1	1	1	1
Maintenance Administration Officer		-	-	-	-	-	-
Maintenance Planner -Electro-mechanical		2	2	2	2	2	2
Maintenance Supervisor		3	3	3	3	3	3
Technical Services							
Chief Mine Engineer	1	1	1	1	1	1	1
Senior Mining Engineer		-	-	-	-	-	-
Mining Engineer		2	2	2	2	2	2
Surveyor		2	2	2	2	2	2
Geotechnical Engineer		-	-	-	-	-	-
Senior Geologist		1	1	1	1	1	1
Geologist		2	2	2	2	2	2
Mine Technicians		2	2	2	2	2	2
Total - Mine Management & Technical	3	23	23	24	23	23	23

19.1.13 Material Handling

Mucking and Hauling

The extracted mineralized rock will be loaded onto 10 t or 20 t trucks and hauled via the decline to surface. Waste, when not used for backfill, will be hauled to surface by 20 t trucks and placed into the waste storage area according to the waste rock management plan.

The anticipated mineralized rock and waste handling system is as follows:

- Waste will be mucked from development headings with a 4 m³ to 6 m³ ejector LHD to either a short term muck bay or loaded directly into 20 t trucks for transport to the surface waste site. Where applicable waste muck will be utilized to fill voids.
- Ore from MCF stopes will be mucked by a 2.5 m³ ejector LHD to re-muck bays or again directly loaded into either 20 t or 10 t trucks depending on stope size.
- Ore from shrinkage stopes will be mucked through a mucking scam utilizing a 2.5 m³ ejector LHD and trucks for surface transport.
- Ore from narrow or modified shrink CF stopes not accessed with rubber tired equipment will be slushed to a drawpoint, followed by LHD and truck transport.
- Ore produced from LH stopes will be mucked by 2.5-4 m³ EOD LHDs with remote control capability. Muck will be placed in muck bays or directly loaded into trucks.

Currently there is no plan to move muck to a transfer pass and chute load into trucks. However, mining above the 625 level may utilize such a scenario.

Ore will be stockpiled on surface in a contained bin or lined pad. A surface loader will load surface haul trucks for transport to the mill. In the case of Bellekeno, there is an opportunity to direct-ship high-grade galena-silver mineralization to a smelter. A typical scenario may be to sort mineralized rock and load sea van containers for direct shipping. Concentrate production is also expected to be containerized.

Crushing

There is no plan for underground crushing. All crushing and screening will be done on surface.

Waste Rock Characterization

For Bellekeno underground exploration and preliminary development it is estimated that 118,500 tonnes of rock will be brought to surface during initial years. It is also estimated that an additional 130,000 tonnes of waste rock may be produced during future underground exploration at Bellekeno at an approximate rate of 30,000 tonnes per year for the next four years.

The property has been subject to extensive geochemical testing over the years and this information has been used to develop onsite criteria for sorting and managing waste rock according to rock characteristics. Table 19.8 shows estimations and classifications of waste rock according to Acidic and/or Metal Leaching potential (AML / non-AML) that have been calculated for initial decline development and exploration over a five year period.

Table 19.8: Waste Rock Tonnage Estimates and AML Classification

Basic Rock Type	Total Estimated Tonnage [t]	Percentage of Unit estimated to be characterized as potentially AML producing	Tonnes AML (approx)	Placement of AML Materials	Tonnage non-AML (for general site construction purposes)
Phase 1: New decline development and rehabilitation – Year -1					
Greenstone	13,500	2%	300	Onek Pit	13,200
Quartzite	95,000	22%	20,900	Onek Pit	74,100
Mineralized (vein) material	5,000	100%	5,000	Temporary Stockpile at 625	0
BK 625 Rehab material	5,000	100%	5,000	Temporary Stockpile at 625	0
TOTAL Phase 1	118,500		31,200		87,300
Phase 2: Annual underground exploration – Years 2 to 5*					
Greenstone	18,000	2%	400	Onek Pit	17,600
Quartzite	102,000	22%	22,400	Onek Pit	79,600
Bulk sample mineralized rock	10,000	100%	10,000	Shipped off site	0
TOTAL Phase 2	130,000		32,800		97,200
TOTAL PROGRAM	248,500		64,000		184,500
*30,000 tonnes per year for years 2 to 5 = 120,000 tonnes					

In total, it is estimated that 248,500 t of waste rock will be produced during the Bellekeno underground exploration and preliminary development program. Approximately 5,000 t may be mineralized / vein material that would be segregated at the Bellekeno 625 portal for future processing or return underground. Another 5,000 t of material is anticipated to be brought to surface during rehabilitation of Bellekeno 625 and will also be stored in this location. Potential AML waste rock will be placed adjacent to the Onek open pit on an existing waste rock dump and covered. The majority of waste rock (74% or 184,500 tonnes) is expected to fall within the non-AML classification and will be primarily used as road fill.

Waste rock is to be field assessed for its geochemical characteristics to determine the waste rock’s potential to generate net acidity and/or elevated levels of soluble metals, so that decisions about placement and use of the material, as well as reclamation measures, can be made on a technically sound basis to protect the environment. Criteria based on easily recognizable characteristics of the waste rock have been developed so that a field classification can be reliably made. These criteria resulted from a review of acid-base accounting analytical data and multi-element analyses of

approximately 6,500 drill core samples from recent Sourdough Hill/Bellekeno drilling, plus samples from nearly 50 other sites for geochemical characterization of the waste rock that will be produced in this program.

The Waste Rock Management Program calls for the site geologist to first map the rock face and sample each rock unit identified before every round is blasted. The boundaries of the units will be spray painted and photographed for later sample result weighting (i.e. weighting is given to the results of each rock unit as a percentage of the constituents of the rock face). Simple visual and hand testing rules, to be undertaken at the geological/engineering office trailer located at the portal site, have been developed in order to make the determination of whether the rock is geochemically benign or not. These tests include fizz tests for carbonate content, visual estimation of sulphide mineralization, and paste pH. In all cases, this testing and determination will be made on a conservative basis.

Based on this determination, directions will be given to the surface crew for hauling and use of the waste rock as follows: rock that is not potentially acidic or metal leaching, or “non-AML” will be used for general construction, principally in building a new access road between Bellekeno East new portal and Bellekeno 625, and some in repairs and surface capping of the existing ‘power line road’ that runs along the north slope of Sourdough Hill, above the left limit of Lightning Creek. Rock brought to surface that is considered potentially AML will be trucked on existing haul roads across Lightning Creek onto Keno Hill, for deposit in a designated area adjacent to the Onek Pit on an impermeable base and covered to prevent infiltration.

19.1.14 Ventilation

Ventilation will be governed by the Yukon Occupational Health and Safety Regulations pertaining to mining and supplemented with regulations from other provinces or the United States to ensure a robust ventilation system design.

At this level of study, a detailed ventilation network is not appropriate and will be developed as more refinement to the mining equipment and systems are completed.

Ventilation Criteria

Ventilation will be designed to meet at a minimum 400-500 $\mu\text{g}/\text{m}^3$ of diesel particulate matter, as is currently in use in the United States but not yet mandated in Canada. In addition, a minimum criteria of 0.06 m^3/s of fresh air for every working kW of diesel power will be used. The velocities in the access drives will be kept around 6 m/s while in the dedicated airways the velocity will increase up to 15 m/s.

Ventilation Allocations

The ventilation allocation will be based on the total diesel equipment kilowatts with additional allocation for underground facilities and number of active workings. It is estimated that the total ventilation volume should not exceed 120 m³/s.

Primary Ventilation Circuit

Initially ventilation will be in-cast into the new Bellekeno East portal through a 75 kW fan with a variable speed drive. Upon breakthrough into the 625 level, air will then be routed down the 99, SW and BK north declines. As new development advances below the existing declines, exhaust ventilation / secondary escape raises will connect the decline to the 625 level. From the 625 level exhaust will be routed up through the 99 raises and eventually exhaust out the 200 level. As an alternative, pending inspection of the 99 raise on breakthrough, exhaust may have to be routed and exhausted through the 525 portal (Figure 19.16). A ventilation door will have to be installed with a fan to exhaust air through the portal.

As development transitions into production the ventilation will change from a forced air system to an exhausting system. An exhaust fan will be installed at the 200 level and the fresh air will be drawn into the mine via the new Bellekeno East ramp. The final number of fans and their sizes will be determined as manpower and diesel equipment becomes more detailed.

The development ventilation system installed initially at the Bellekeno East portal will become a permanent supply ventilation installation when the project advances into the production stage.

Auxiliary Ventilation

Production headings will be ventilated with auxiliary axial flow fans and duct depending on the specific requirements of each area. It is estimated that there will be a requirement for a total of 10-12 auxiliary fans.

Once the through flow ventilation circuit is established on the level, the ventilation flow will be controlled by either regulators or ventilation doors, depending on the level arrangement.

Secondary ingress/egress will be maintained via the original 625 level tracked drift and portal. The exhaust raises in the 99 zone, SW and North ramp will also serve the dual purpose of exhaust and secondary escape way. The raise will be inclined at >60° and equipped with steel ladders and cage. Located in the ramps at approximately 500 m intervals will be refuge chambers equipped with mine page phones, plumbed air and water, potable water, cylinder air, sealant, first aid and CO₂ purge valve.

All underground equipment will be fitted with oxygen-generating self rescuers (SCSR's). All underground personnel will be equipped with W-65 self rescuers.

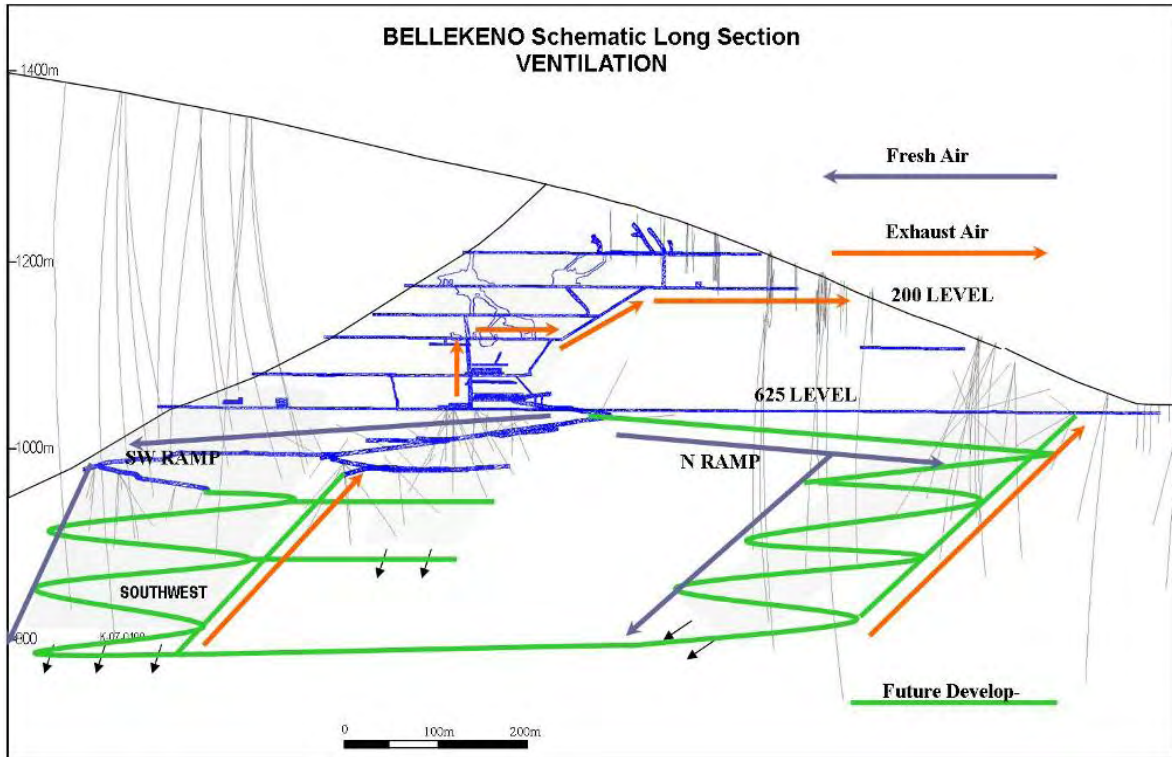

Figure 19.16: Schematic Ventilation flow

Mine Air Heating

The purpose of the mine air heating system will be to raise the temperature of the mine intake air entering the decline portal to 2°C during the winter months. The basis for heating the mine air to above freezing is to:

- Prevent the mine services from freezing including compressed air (condensation), mine water and water discharge;
- Keep the decline road free of ice;
- Improve ergonomics and reduce cold related stress.

Table 19.9 has the average, minimum and maximum temperature ranges for Mayo, YT. In six months of the year the average daily temperature dips below 0°C and the average daily minimum temperature is -26.2°C.

Table 19.9: Average Temperatures for Mayo, YT (°C)

Temperature	Jan	Feb	Mar	Apr	May	Jun	Jul	Aug	Sep	Oct	Nov	Dec	Year
Daily Average	-26	-19	-9.6	0.9	8.4	14	16	13	6.4	-3	-16	-22	-3.1
Daily Maximum	-21	-13	-2.8	6.8	14.8	21	23	20	12	1.1	-11	-17	2.8
Daily Minimum	-31	-25	-16	-5	2	7.1	9.3	6.4	0.8	-7	-21	-28	-8.9

Mine air heat sources for mine portal heat include propane fired heaters of which Alexco has two 4.6 Mbtu heaters. An additional 4.6 Mbtu heater will be needed for full production. All services (air, water and discharge) will be heat traced and insulated.

19.1.15 Mine Infrastructure

Mine Water

For the Bellekeno East decline advanced exploration and development program, water for drilling purposes and dust suppression will be sourced from either Thunder Gulch or Lightning Creek using either infiltration wells or via a direct screened pump intake in the creek. The pump intake will be screened to prevent fish entrainment in accordance with DFO specifications.

For the decline development, water will be piped or trucked to the Bellekeno East portal for use. Where possible, water would be recycled from the underground sumps or the temporary sediment ponds to supplement drill water use. Once the decline has intercepted the historic Bellekeno 625 workings water will be piped via the Bellekeno 625 adit from the water sources.

Total Water Usage

This project will require water use for the exploration camp and underground development and drilling. Water use for these purposes was estimated to be approximately 100 m³/day.

Dewatering Bellekeno

When the Bellekeno East ramp breaks into the 625 level, and dewatering is initiated ahead of rehabilitation of the historic 99 and SW ramps, it is estimated that a total of 17,400 m³ of water will have to be pumped and treated by the existing lime treatment facility located at Bellekeno 625. The pumping rate is contingent on water treatment (lime) capacity and advance rate of the underground rehabilitation.

At a pumping rate of 4 to 5 l/s it would take approximately 40 to 50 days of continuous pumping to dewater the entire mine. Taking into account possible breaks in pumping, dewatering would likely span over two months.

Water Discharge

Four identical pump skids will be located at various elevations in the Bellekeno East decline, 99, SW and North ramp. Water will be lifted to the pump/sump location(s) and re-pumped to the final sump.

Each unitized skid is equipped with two pumps (one operating and one stand-by), controls, and an agitated holding tank or sump with 30,000 l of storage capacity. In the development heading, and finally at the sump arrangement on the 600 m Level, submersible pumps will deliver to the series of sumps. All levels are equipped with level sumps and drain holes.

Water Treatment

From the final sump water will be pumped out to the 625 portal where it will be treated for zinc and released.

Mine Compressed Air

Initially the Bellekeno East decline will be serviced by two portable compressors: Gardner Denver Roto-Screw 800 and 750. One compressor will be online while the other is on standby. Once the rehabilitation is complete and the ramp broken through, the mine will be serviced by electric compressors located at the Bellekeno compressor shed.

The shed currently has one Twistair 750 / 110 PSIG electric compressor. A second, similar compressor will be moved from the Silver King site.

Compressed air will be delivered via 102 mm schedule 10 steel pipe reduced to 51 mm steel pipe and hose in the production headings.

Mine Equipment Workshop

An existing surface workshop consisting of two service bays will be used and extended if required.

Fuel Bays

Fuel bays may not be required as trucks will fuel on surface and underground LHDs will be serviced by fuel truck

Underground Refuge Stations

There would be a portable underground refuge station about 3 mW x 6 mL equipped with potable water, compressed air and breathing apparatus.

Mine Offices

Mine offices will be located within the surface structures.

Underground Communications

A two-way underground communication (a Wi-Fi system or a leaky feeder system) will be installed.

A secondary communications system comprised of self-contained battery operated Femco Mine Telephones will be installed.

Site Layout and Ancillary Facilities

The proposed portal at BK East is located on a steep slope above Thunder Gulch, a narrow tributary of Lightning Creek. The lack of space at the portal site will necessitate that the mine surface plant will have to be laid out in a long, narrow manner. There will be road access to the portal, with the road being widened near the portal by using sand and aggregate from the adjacent placer mine. This area will accommodate the dry/first aid station/office, generators and compressor sheds, several sea-cans to be used for storage, mine air heater, ventilation fan and other equipment. Fuel storage will be kept at the Bellekeno 625 portal and delivered to the BK East in small environmental tanks.

Approximately 150 m up the valley, a sump/settling pond will be built in the placer waste material. This sump will be used to settle cuttings and other solids contained in water pumped from the decline. If the water quality meets release standards, it will be allowed to overflow into Thunder Gulch. If not, it will be sent via pipeline to the treatment facility located at the Bellekeno 625 portal.

19.2 Recoverability

The results from the 1996 Process Research Associates and 2007 SGS Lakefield locked cycle tests were used for the preliminary estimate of metallurgical performances. Table 19.10 shows the assumed metallurgical performance.

Table 19.10: Assumed PEA Metallurgical Performance

Mineralization Zone	Product	Grade				Recovery			
		Ag (g/t)	Pb (%)	Zn (%)	Au (g/t)	Ag (%)	Pb (%)	Zn (%)	Au (%)
99 and Southwest Zones	Pb/Ag Conc	4,782	72.0	1.5	0.6	87.1	96.5	6.9	50.0
	Zn Conc	1,159	2.6	52.0	0.5	8.0	1.3	90.2	17.0
	Tailing	87	0.5	0.2	0.1	4.9	2.2	2.9	33.0
	Feed	1,221	16.6	4.9	0.3	100.0	100.0	100.0	100.0
East Zone	Pb/Ag Conc	7,021	60.0	6.0	10.5	72.2	80.0	0.8	41.5
	Zn Conc	60	0.4	55.0	0.3	8.5	7.4	96.0	18.1
	Tailing	69	0.3	1.0	0.4	19.3	12.6	3.2	40.4
	Feed	232	1.8	19.0	0.6	100.0	100.0	100.0	100.0

19.3 Markets

The Bellekeno project will produce a lead concentrate containing the majority of the recovered silver as well as a separate zinc concentrate. The high silver grade of the lead concentrate will make it a desirable concentrate for smelters. Historically, the lead and zinc concentrates produced from the Keno Hill Silver District were transported and further refined at the Cominco smelter in Trail, BC. Containerized road, rail and ocean (barge) transportation options are available to access the Trail smelter and points beyond. Given the relatively low volumes of concentrate anticipated to be produced (~28,000 tonnes/year combined lead and zinc concentrates), deliveries to overseas smelters would necessarily be infrequent as large ocean vessels will require larger minimum volumes per sailing, and may require modification of vessel loading facilities in Skagway, Alaska,

the nearest suitable port. The use of the port of Skagway may result in higher initial and working capital requirements.

For this study, it was assumed that the concentrates will be transported to trail. Concentrate transportation will be via 20' ocean containers trucked from Elsa to the port of Skagway, ocean barge to Seattle, WA and then transported by truck to Trail, BC.

The assumed smelter terms are:

- \$140 US/dmt treatment charge for lead concentrate
- \$225 US/dmt treatment charge for zinc concentrate
- Payment of 95% of the lead content in the lead concentrate
- Payment of 90% of the silver content in the lead concentrate
- Payment of 65% of the silver content in the zinc concentrate
- Payment of 85% of the zinc content in the zinc concentrate
- \$0.35 US/ounce treatment charge for silver

In addition to the treatment charges, there would be additional penalties if deleterious elements including antimony, arsenic, cadmium and selenium are present above certain penalty thresholds. Based on the metallurgical test results, antimony in the lead concentrate and cadmium in the zinc concentrate are above potential threshold levels and penalty charges have been included in the financial model.

19.4 Contracts

There are no established contracts of significance currently in place for the Bellekeno project except for the development of the exploration decline and the rehabilitation of the 625 adit by Procon Mining and Tunnelling. The terms of the contract with Procon are within industry norms.

19.5 Environmental Considerations

19.5.1 Environmental Setting

The United Keno Hill Mine property including the Bellekeno mine has been a site of active mining activity, (both placer and hardrock) for over 90 years. Although no active hardrock mining is currently occurring, active placer operations are located adjacent to the Bellekeno mine.

As described in section 4 of the "Mineral Resource Estimation, Bellekeno Project, Yukon Territory, Canada"(January 28, 2008, prepared by SRK Consulting (Canada) Inc.), the United Keno Hill Mine property is located in central Yukon Territory and is characterized by a sub-arctic continental climate with cold winters and warm summers. Average temperatures in the winter are between minus fifteen and minus twenty degrees Celsius but can reach as low as minus sixty degrees Celsius.

Annual precipitation averages 280 mm; half of this amount falls as snow, which starts to accumulate in October and remains into May or early June. Evapotranspiration is estimated to be in the order of 200 mm. The landscape around the project area is characterized by rolling hills and mountains with a relief of up to 1200 masl. The highest elevation is Keno Hill with 1975 masl. Vegetation is abundant with northern boreal forests occupying lower slopes and valley bottoms, and open and forest fringe areas of willow and scrub birch near hilltops. The hamlet of Keno City, a community with population of 15, is located approximately 2.5 km to the east of the Bellekeno project area. The town of Mayo is located approximately 60 road kilometres to the southwest, and has a population of approximately 250.

The region has been valuable to First Nations in the region for centuries for hunting and gathering and it also accommodates a variety of anthropogenic activities. Active trapping still occurs in the area and it is known and used for recreational pursuits.

The entire district supports a wide variety of wildlife including a unique population of butterflies. In spite of a long history of mining in the region the area supports wildlife resource utilization/exploitation by the local community and First Nations. Local knowledge and observations indicate that wildlife habitat is regenerating and wildlife populations are being sustained. Species at risk whose ranges may or do extend into the Keno Hill Silver District include peregrine falcon, grizzly bear, wolverine, short-eared owl, mule deer, elk and cougar.

The Keno Hill property is located in the traditional territory of the Nä-cho N'yak Dun First Nation (NNDFN). Alexco/ERDC and NNDFN have in place a Cooperation and Benefits Agreement. This agreement will be expanded once a production decision is made at Bellekeno. The agreement provides that ERDC and NNDFN will work collaboratively in good faith to ensure meaningful participation of NNDFN in the regulatory processes related to mining development in the region.

Alexco's wholly owned subsidiary, Elsa Reclamation and Development Company Ltd (ERDC) currently holds a type 'B' water license (QZ06-074) to conduct Care and Maintenance on the site, including continuous water treatment at four adit sites and seasonal treatment at the Valley tailings location. A key environmental issue with respect to the Bellekeno mine site is surface water quality. Free draining water from the existing Bellekeno 625 level adit is of neutral pH however has elevated levels of metals, in particular zinc. Zinc, which has been shown to be an indicator of water quality in the region, is soluble over a wide range of pH conditions. Water flowing from the Bellekeno 625 adit ranges in flow rates from 1 to 10 l/s is captured and treated in a simple lime precipitation treatment system and discharged to the local receiving environment. Water license QZ06-074 outlines the discharge criteria and compliance conditions for operation of the Bellekeno treatment system.

Studies to date indicate that the majority of Bellekeno waste rock has minimal potential for generation of net acidity and/or metal leaching. Nonetheless, analyses both at Bellekeno and in the district indicate that some rock, particularly rock occurring close to mineralized systems, has

slightly elevated sulphide and metals and will require segregation and appropriate storage in order to minimize effects to the receiving environment.

19.5.2 Environmental Studies

Several in-depth environmental studies have been completed in the Keno Hill area. A comprehensive Site Characterization Report for the Keno Hill Silver Mining District was prepared by Access Consulting Group (now a wholly owned subsidiary to Alexco Resource Corp.) in 1996 (Access Mining Consultants Ltd., June 3, 1996. United Keno Hill Mines Limited, Report No. UKH/96/01, Site Characterization) and describes in detail all environmental aspects of the area including:

- Historic information on development in the region;
- Regional description of the environment;
- Detailed geochemical description of the area;
- Site wide detailed description of water quality; and
- Environmental impact assessment

Additional studies were also completed by Public Works and Government Services Canada (PWGSC) in a report entitled “Keno Valley/Dublin Gulch Environmental Baseline Assessment”, March 2000. As part of the condition for the purchase of the assets of the UKHM property, Alexco Resource Corp. commissioned a Baseline Environmental Assessment of the property. SRK Consulting was contracted by Alexco Resource Corp. to conduct site inspections as part of this assessment. SRK completed a final report in 2007 entitled “Baseline Environmental Report, United Keno Hill Mines Property”, April 2007.

As described in Section 16.5.1, several potential areas for construction of the processing facilities have been identified. Section 19.1.13 describes key aspects of the Waste Rock Management Plan has been developed for the advanced underground exploration program at Bellekeno and it will serve as the basis for future management of underground waste material during operations. Environmental and socioeconomic issues associated with tailings will be identified and addressed in a future tailings management plan and attendant environmental assessment and permitting. The 1996 Site Characterization Report, described above, contains detailed geochemical description of waste rock and tailings at the site (from previous operations); further to this, additional analyses for the Bellekeno waste and mineralized rock were conducted in late 2007. This information will serve to expedite the development of both Waste Rock and Tailings Management Plans required for production planning at the site. Further geotechnical investigations will be required prior to determining final location of the mill, tailings and waste rock dumps. A reconnaissance-level hydrogeological study will be required to identify the preferred locations for the process water supply wells.

19.5.3 Regulatory Regime

A major hard rock mining project in the Yukon moving to development and/or production requires a detailed environmental and socio-economic assessment and various regulatory approvals, including but not limited to a Type A or B Water License and a Quartz Mining License. Future production at the Bellekeno mine will require both a Type A Water License and a Quartz Mining Licence.

There are two distinct stages that a project goes through before mining activity can commence. First, an assessment identifies environmental and socio-economic effects, their significance, and related mitigation measures. Secondly, there is the regulatory stage where regulators issue their respective permits, licenses or other authorizations as the case may be.

Environmental assessments in the Yukon are governed by the Yukon Environmental and Socio-economic and Assessment Act (YESAA). YESAA sets out how assessments will be done for a variety of activities, including projects, existing projects and plans. Assessments look at the environmental and socio-economic effects (positive and negative) of activities and integrate scientific information, traditional knowledge and other local knowledge in all assessments. The assessment process incorporates principles that include recognizing and enhancing traditional First Nation economies and providing participation opportunities for interested persons.

In general, assessors will look at the potential environmental and socio-economic effects of proposed activities and recommend whether the activities should proceed, proceed with terms and conditions, or not proceed. When assessments are complete, recommendations with reasons will be forwarded to the relevant decision bodies. The federal government, territorial government or First Nations, as decision bodies for the activities, will receive the recommendations from the assessor with all relevant project information. The decision body (or bodies) will then decide whether to accept, reject or vary the recommendations of the assessor, and will issue a decision document. Once a decision document is issued, both the water licence and quartz mining licence can be obtained. Water licences are issued by the Yukon Water Board. The Board has specific responsibilities under YESA. The Board cannot issue a water use licence, or set terms of a licence, that are contrary to a decision document issued under that legislation. For this reason, an application for a water use licence must be accompanied by a decision document issued under YESAA. Quartz Mining Licences are issued by the Energy Mines and Resources branch of the Yukon Government. The Quartz Mining License will contain terms and conditions regarding reclamation of mining activities as well as financial security for reclamation and closure activities. Reclamation under the Quartz Mining License includes terrestrial impacts of the mining operation. Activities related to the use of water or deposit of waste into water will continue to be covered under the mine's Water Licence.

19.5.4 Project Permitting

Existing Permits. The ongoing advanced exploration activities for the Bellekeno project are conducted under a Mining Land Use Permit recently issued by the Energy Mines and Resources

branch of the Yukon Government, which replaced the previous mining land use permit. This updated permit grants Alexco approval to complete an advanced underground exploration program, extract a bulk sample from the silver rich Southwest Zone, and rehabilitate the historic workings in preparation for a production decision in early 2009. Permitting for a Type B Water Use Licence required for mine dewatering is well underway.

Construction and Production Permitting. An application including the project description with assessment of associated environmental impacts and mitigation will be submitted to the Yukon Environmental and Socio-economic and Assessment Board. As a condition of the production Water and Quartz Mining Licences, a comprehensive reclamation and closure plan will be developed. The plan will address final closure of the Bellekeno mine including reclamation objectives, progressive reclamation plans, removal of facilities and structures, closure of tailings and waste rock storage areas, reclamation and re-vegetation of the surface disturbances, protection of water resources and a cost estimate to close and reclaim the mine. Financial security to implement the reclamation and closure plan will be posted with the appropriate regulatory agency. Financial security can be posted in a number of fashions but the most common is cash or a letter of credit.

19.5.5 Closure

The Bellekeno Mine development is a brownfields project located within a historic mining area. While development of the Bellekeno project will mainly affect previously impacted sites, there is expected to be some disturbance to new areas.

Progressive reclamation will be incorporated into the operating plans and used and credited to offset future closure liabilities and cost estimates. The project plan as considered in this report incorporates several important mitigation features that serve to substantially minimize both surface disturbance and end-of-mine closure obligations, including:

- Dewatering tailings to produce a 'dry-stackable' product;
- Minimizing sulphide content in tailings by production of a pyrite concentrate;
- Paste backfilling of approximately 50 percent of tailings, and
- Utilizing waste rock as underground backfill where possible.

Studies to further optimize tailings and waste rock handling are expected to continue during the next 18 months.

Alexco's senior management team has a demonstrated track record for reclamation and closure performance at the Brewery Creek mine site in the Yukon, which received the Department of Indian Affairs and Northern Development Robert E. Leckie Award for Outstanding Reclamation Practices in both 1999 and 2002. In 2003, industry and government representatives praised the work completed at Brewery Creek for leadership and innovation in mine reclamation technology.

The economic analysis in Section 19.7 includes closure costs to complete reclamation using best practices including dismantling of facilities, sealing the Bellekeno adit, re-vegetation of waste rock storage areas and remediation of any contaminated areas.

19.6 Taxes

The economic analysis has been done on a pre-tax basis.

The Canadian mining taxation regime is essentially a three-tiered tax system:

- Federal income tax is levied on a mining operation's taxable income (generally being net of operating expenses, depreciation allowance on capital assets and the deduction of exploration and pre-production development costs);
- Provincial and territorial income taxes are based on the same (or similar) taxable income; and
- Provincial and territorial mining taxes, duties, or royalties are levied on a separate measure of production profits or revenues.

Federal and Yukon Incomes Taxes

The current Federal corporate income tax rate for 2008 is 19.5% and will be decreasing in phases to 15% by 2012 under mandated reductions. The Yukon income tax rate is 15%, levied on taxable income as calculated for Federal purposes.

Yukon Mining Taxes

Yukon mines are taxed under the Quartz Mining Act, legislation that originally dates from the 1800s. Under this legislation, mining taxes in the Yukon are based on gross mining profit (NSR less operating costs) but the taxable basis differs from the Federal calculations. Specifically, the annual depreciation for Yukon purposes is calculated as 15% on a straight-line basis and royalties and interest expense are non-deductible; however, Federal and Yukon corporate income taxes paid are deductible.

Annual royalties are payable with respect to mines based in the Yukon if the combined annual taxable mining profits of all Yukon-based mines under common management for a calendar year exceed \$10,000. The annual royalty is calculated as follows:

- 3% on combined annual profits in excess of \$10,000 and up to \$1 million;
- 5% on combined annual profits in excess of \$1 million and up to \$5 million;
- 6% on combined annual profits in excess of \$5 million and up to \$10 million;
- A proportional increase of 1% for each additional \$5 million of combined annual profits in excess of \$10 million (no maximum).

19.7 Capital and Operating Cost Estimates

19.7.1 Operating Cost Estimate

Mine Operation Cost Estimate

Operating cost estimates have been collected from number of sources including:

- Mine Cost Service 2007 (InfoMine);
- Rescan Engineering, 1996 Feasibility study;
- SRK Consulting, 2005 Ken Reipas;
- Procon Mining and Tunneling 2007;
- Industry Peers and Associates; personal communication;
- Quotes from contractors and vendors.

In some cases where costs were historical they were adjusted for inflation and escalated by CPI (Consumer Price Index) formulas to bring them to the present. The best source of data has been the InfoMine – Mine Cost Service ver. 2007 and direct quotes from vendors.

The annual estimated unit mine operating costs are shown in Table 19.11 divided into mine operation and mine development. Table 19.12 shows a summary of the average unit mine operating costs by activity.

Table 19.11: Mine Unit Operating Cost (\$/t milled)

Operation	Year				
	1	2	3	4	5
Mine Operating	79.26	79.26	79.26	79.26	79.26
Mine Development	32.19	52.73	41.18	32.96	34.51
Total Unit Mine Operating Costs	111.45	131.99	120.44	112.22	113.77

Table 19.12: Summary of Unit Mine Operating Costs by Activity (\$/t milled)

Activity	\$/tonne
Stopes	17.45
(Re-Access) Drifts	9.59
Cross cuts	9.58
Draw Points	2.76
Access Raises	2.65
Ventilation Raises	0.94
Services	11.94
Ventilation	0.97
Maintenance	1.82
Administration	14.61
Miscellaneous	6.95
Total Unit Mine Opex	\$ 79.26

Mineral Processing Operating Cost Estimate

The average annual processing cost for the process plant is estimated to be approximately \$6.8 million or \$46/t milled during full operation at a 408 t/d processing rate. The operating cost will be higher during initial operation with a 227 t/d processing rate. The unit cost at this stage will be approximately \$5.4 million or \$64/t of processed ore.

This estimate includes:

- Staffing and salary/wage level estimates, based on manpower requirements for the plant; also, a 50% burden is added to the base salary for pension plan, CPP, EI, WCB, insurance, and tool allowance costs.
- Power consumption estimates, based on the Bond work index (Wi) equation for ball and regrind mills, and equipment load list power draw estimates for the rest of the concentrator equipment.
- A unit power cost of \$0.15/kWh, as provided by Alexco.
- Major consumables estimates, based on the abrasion index for steel consumption and laboratory preliminary dosages for reagents.
- Maintenance cost estimates, based on approximately 5% of major equipment capital costs.
- Major consumables unit prices, based on estimated market prices.
- General and administration expense estimates are based on potential labour requirements, and administration service and supplies have been provided by Alexco.

Table 19.13 and Table 19.14 show the labour requirement and operating cost summary for both initial and full operation for the mineral processing plant while Table 19.15 shows the total estimated operating cost per tonne milled.

Table 19.13: Process Operating Cost Summary – Initial Two Years

Description	Labour	Annual Cost (\$/year)	Unit Cost (\$/tonne ore)
Process Work Force			
Supervision	9	1,136,610	13.73
Operation	18	1,603,080	19.37
Maintenance	10	946,080	11.43
Sub-total	37	3,685,770	44.52
Supplies			
Consumables		453,833	5.48
Maintenance/Operating Supplies		400,000	4.83
Power Supply		785,772	9.49
Others		27,778	0.34
Sub-total		1,667,383	20.14
Total Process – Initial Years	37	\$5,353,153	\$64.67

Table 19.14: Process Operating Cost Summary – Full Operation

Description	Labour	Annual Cost (\$/year)	Unit Cost (\$/tonne ore)
Process Work Force			
Supervision	9	1,136,610	7.63
Operation	18	1,603,080	10.76
Maintenance	10	946,080	6.35
Sub-total	37	3,685,770	24.74
Supplies			
Consumables		813,592	5.46
Maintenance/Operating Supplies		720,000	4.83
Power Supply		1,571,544	10.55
Others		50,000	0.34
Sub-total		3,155,136	21.17
Total Process – Full Operation	37	\$6,840,906	\$45.91

Table 19.15: Total Unit Operating Cost (\$/t milled)

Operating Costs	Year 1	Year 2	Year 3	Year 4	Year 5
Mine Operating	79.26	79.26	79.26	79.26	79.26
Mine Development	32.19	52.73	41.18	32.96	34.51
Processing	64.67	64.67	45.91	45.91	45.91
G&A	36.93	36.93	23.08	23.08	24.17
Total Unit Operating Costs	213.05	233.60	189.43	181.21	183.84

The total operating cost estimate per tonne is exclusive of:

- Surface and Underground Exploration, but includes definition, pre-production and mine operations diamond drilling. Underground exploration development is included in sustaining capital.
- Contingency;
- Contributions to the reclamation fund;
- Yukon royalties; and
- Depreciation and amortization.

19.7.2 Capital Cost Estimate

Mine Capital Cost Estimate

Capital Cost for mining has been derived from costs at similar operations, “Mine Cost Services and quotes from manufacturers. The costs comprise of mine equipment and advanced development as indicated in Tables 19.16 and 19.17.

Table 19.16: Mining Capital Cost Estimate (\$'000)

Capital Costs (\$'000)	Year					Total
	-2	-1	1	2	3	
Mine Equipment		6,768	1,020	2,780	676	11,244
Mine Development		2,825				2,825
Exploration Development		1,320	1,360	2,680	2,680	8,040
BK East Advanced Exploration	10,000					10,000
Total Capital Mining	10,000	10,913	2,380	5,460	3,356	32,109

Table 19.17: Capital Cost Equipment (\$'000)

Item	\$'000/Unit	Year				Total Item
		-1	1	2	3	
COSTS (Mine)						
East Decline	4	-	-	-	-	-
Ventilation Primary (Inc. main fan)	630	315	315	-	-	630
Heating Plant	150	150	-	-	-	150
Compressors (Portable)	70	-	-	-	70	70
Sump/Pump Station	95	-	-	95	-	95
Explosive Storage	50	-	-	50	-	50
Sub-Total		465	315	145	70	995
Machinery & Equipment – COSTS						
2-Boom Jumbo Drill	750	750	-	-	-	750
1x- single Boom Jumbo	400	400	-	400	-	800
3.5 m ³ LHD	685	685	-	685	-	1,370
2.0 m ³ LHD	425	425	-	425	-	850
0.75 m ³ LHD	260	260	-	-	-	260
20 – Tonne Truck	520	520	-	520	-	1,040
10 - Tonne Truck	230	230	-	230	-	460
Diesel-electric Jumbo	430	430	-	-	-	430
Long Hole Bench Drill	350	-	-	-	350	350
Bolter	450	450	-	-	-	450
Scissor Lift	220	220	-	-	-	220
Flat bed Crane Truck	200	220	-	-	-	220
Service Truck	240	240	-	-	-	240
U/G Tractors	40	40	80	80	40	240
Small Dozer	50	-	50	-	-	50
U/G Grader	350	350	-	-	-	350
Utility Vehicle	300	300	-	-	-	300
Communication System	25	25	-	-	-	25
Shotcrete System	260	260	-	-	-	260
Personal Carriers	200	-	200	-	-	200
Jacklegs	6	36	-	36	24	96
Stoppers	7	42	-	42	28	112
3 drum electric slushers	34	-	-	34	68	102
2 – 2 x drum slushers	28	-	-	28	56	84
Sump sucker	25	25	-	-	-	25
37 kW fans	15	30	-	30	-	60
55 kW Fans	20	40	-	40	-	80
Electric pumps various sizes from 10 hp to 50 hp	20	40	40	-	40	120
Mine rescue units and parts (\$100K)	10	80	-	-	-	80
4160 power cable 3000m	120	120	-	-	-	120
Sub stations 75 KVA	85	85	85	85	-	255
Switch gear room	250	-	250	-	-	250
Sub-Total Equipment/year		6,303	705	2,635	606	10,249
TOTAL Mine		6,768	1,020	2,780	676	11,244

Plant and Infrastructure Capital Cost Estimate

The capital cost estimate for the Bellekeno Project scoping study was developed based on the mobile crushing circuit, primary grinding mill, flotation plant, ancillary facilities, and infrastructure as previously defined.

The capital cost estimate is based on general arrangements, scoping, and quantity takeoffs, as well as supplier quotations. The accuracy of the scoping study estimate is in the range of $\pm 35\%$. Table 19.18 shows the capital cost summary for process circuit.

Table 19.18: Process Capital Cost Summary

Description	Total Costs (\$'000)
Direct Costs	
Civil Works	1,960
Concrete	958
Structural and Miscellaneous Steel	803
Architectural/Building Services	2,487
Process Equipment Mechanical	8,098
Process Piping	1,255
Process Electrical	2,537
Process Instrumentation	752
Total Direct Cost	18,850
Indirect Costs	
Construction Indirect	1,319
Freight	1,076
Spares/Initial Fills	418
EP	1,544
CM	1,118
Commissioning	250
Owner's Cost	750
Insurance	150
Total Indirect Cost	6,625
Total Directs & Indirect Cost	25,475

A summary of the direct and sustaining capital through the LOM is presented in Table 19.19.

Table 19.19: Bellekeno Project Capital Estimate (\$'000)

Capital Costs (\$'000)	Year							Total
	-2	-1	1	2	3	4	5	
Construction Capital								
Mine Equipment		6,768						6,768
Mine Development		2,825						2,825
BK East Advanced Exploration	10,000							10,000
Process Plant & Infrastructure		18,850						18,850
Total Direct	10,000	28,443						38,443
Indirect		6,625						6,625
Contingency (25%)	2,500	8,767						11,267
Initial Working Capital			4,860				-4,860	0
Total Construction Capital	12,500	43,835	4,860				-4,860	56,335
Sustaining Capital								
Mine Equipment			1,020	2,780	676			4,476
Closure Cost		500	250	250	250	250	250	1,750
Exploration Development		1,320	1,360	2,680	2,680			8,040
Total Sustaining Capital		1,820	2,630	5,710	3,606	250	250	14,266
TOTAL CAPITAL	12,500	45,655	7,490	5,710	3,606	250	-4,610	70,601

Not included in the estimate are: taxes and depreciation.

19.8 Economic Analysis

19.8.1 Introduction

The economic evaluation indicates a base case pre-tax internal rate of return of 55.5% and a pre-tax net present value of US\$87 million at a discount rate of 8.0% for the Bellekeno deposit. Detailed financial evaluation worksheets can be found in Appendix A.

The pre-tax base case financial model is calculated within the following parameters:

- mine and mill construction will start in 2009 with commissioning in 2010
- current advanced exploration costs for Bellekeno of \$10 million included in the initial capital
- base case metals pricing is three-year rolling average metal prices
- base case three-year average US/Canadian exchange rate
- assumed current net smelter terms
- five-year mine life
- SW+99 Zone to commence in Year 1 and East Zone comes on line in Year 3
- 1.5% NSR royalty capped at \$4.0 million, commencing after payback of capital

- resources as per SRK Technical Report dated January 28, 2008
- closure and reclamation costs included
- the model was prepared on a pre-tax basis
- Working capital recovered in year 5
- Depreciation costs are not calculated.

19.8.2 NPV and IRR Summary

This study presents the predicted NPV and IRR for the project and a sensitivity analysis of key variables including metal prices, exchange rates, capital and operating costs and production tonnes. Initial and sustaining capital has been assumed on a year-by-year basis for the life of the Project.

The initial capital includes all capital expenditure prior to first production of mineral concentrate from the process plant; sustaining capital includes all subsequent capital expenditure, including equipment replacement based on predicted equipment life. Contingency varies by project area, depending on the predicted level of risk. An overall 25% contingency is included in the construction capital costs. A working capital of \$4.86 M (3-months operating cost) is included in Year 1 and is recovered in Year 5. A discounted cash flow rate of 8.0% was assumed.

The net revenue is defined as the gross revenue less costs incurred subsequent to concentrating, which includes transportation, insurance, and refining. No provision is made for deducting mine operating costs for this calculation. Operating cash flow is defined as the net revenue less mine operating costs. The summary of pricing scenarios is in Table 19.20. The cash flow analysis is presented in Table 19.22.

Table 19.20: Economic Evaluation at Various Metal Prices

Parameter	Units	Base Case 3 Year Average ¹	Current Metal Prices ²	Forward Looking Metal Prices and Exchange Rates ³		
				2010	2011	2012 and Beyond
Payback Period	years	1.6	1.3	1.4		
IRR (pre-tax)	%	55.5	64	48.5		
NPV at 8% (pre-tax)	US\$Million	87	106.7	57.1		
Prices				2010	2011	2012 and Beyond
Lead	US\$/lb	0.81	0.78	0.70	0.50	0.50
Zinc	US\$/lb	1.24	0.84	1.00	0.90	0.75
Silver	US\$/oz	11.69	17.92	16.00	14.50	12.25
Gold	US\$/oz	625.60	935.25	890.00	780.00	700.00
Exchange Rate	US\$/C\$	0.89	0.98	0.95	0.93	0.90

NOTE:

1. Prices are quoted from London Metal Exchange and are rolling averages through May 2008.
2. Current metal prices as of July 2, 2008
3. Based on Alexco-compiled consensus long-term commodity price and exchange forecasts as of June 19, 2008 as published publicly by a basket of independent Canadian and US investment analysts

Table 19.21: Base Case Cash Flow Analysis

Cash Flow	Units	Year						
		-2	-1	1	2	3	4	5
Summary SW + 99								
Net Revenue	US\$M	\$ -	\$ -	\$ 55.9	\$55.9	\$55.9	\$ 55.9	\$ 26.8
Royalty Payments	US\$M	\$ -	\$ -	\$ -	\$ 0.3	\$ 0.8	\$ 0.8	\$ 0.4
Operating Cost	US\$M	\$ -	\$ -	\$ 17.3	\$19.0	\$15.4	\$ 14.7	\$ 7.2
Capital Costs	US\$M	\$ 11.1	\$ 40.7	\$ 6.7	\$ 5.1	\$ 3.2	\$ 0.2	\$ (4.1)
Summary East Zone								
Net Revenue	US\$M	\$ -	\$ -	\$ -	\$ -	\$18.2	\$ 18.2	\$ 31.8
Royalty Payments	US\$M	\$ -	\$ -	\$ -	\$ -	\$ 0.3	\$ 0.3	\$ 0.5
Operating Cost	US\$M	\$ -	\$ -	\$ -	\$ -	\$ 9.2	\$ 8.8	\$ 15.7
Capital Costs	US\$M	\$ -	\$ -	\$ -	\$ -	\$ -	\$ -	\$ -
Summary All Zones								
Net Revenue	US\$M	\$ -	\$ -	\$ 55.9	\$55.9	\$74.1	\$ 74.1	\$ 58.6
Royalty Payments	US\$M	\$ -	\$ -	\$ -	\$ 0.3	\$ 1.1	\$ 1.1	\$ 0.9
Operating Costs	US\$M	\$ -	\$ -	\$ 17.3	\$19.0	\$24.7	\$ 23.6	\$ 22.9
Capital Costs Pre-Production and Sustaining	US\$M	\$ 11.1	\$ 40.7	\$ 6.7	\$ 5.1	\$ 3.2	\$ 0.2	\$ (4.1)
Pre-Tax Cash Flow	US\$M	\$(11.1)	\$(40.7)	\$ 31.9	\$31.5	\$44.8	\$ 48.9	\$ 38.5
Pre-tax Cash Flow	C\$M	\$(12.5)	\$(45.7)	\$ 35.7	\$35.3	\$50.2	\$ 54.8	\$ 43.1
Pre-tax Accumulated Cash Flow	US\$M	\$(11.1)	\$(51.9)	\$(20.0)	\$ 11.5	\$56.3	\$105.2	\$143.7
Pre-tax Discounted Cash Flow	US\$M	\$(10.3)	\$(34.9)	\$ 25.3	\$23.2	\$30.5	\$ 30.8	\$ 22.4
Pre-tax Accumulated Discounted Cash Flow	US\$M	\$(10.3)	\$(45.2)	\$(19.9)	\$ 3.2	\$33.7	\$ 64.5	\$ 87.0

19.8.3 Sensitivity Analysis

Sensitivities to metal prices, exchange rate, capital and operating costs and production tonnage on the IRR and NPV were conducted. Spider charts for the sensitivity cases are presented in Figures 19.2 to 19.4. It is observed that NPV is most sensitive to exchange rate, tonnes and silver price. IRR is most sensitive to exchange rate, initial capital expense, and operating cost.

It must be noted that concentrate grades and metal recoveries are related to feed grades but the model does not provide clear connection to the relationship between the head grade and metal recoveries due to using the fixed average head grades. The model is calculated based on concentrate grades from locked cycle metallurgical test works.

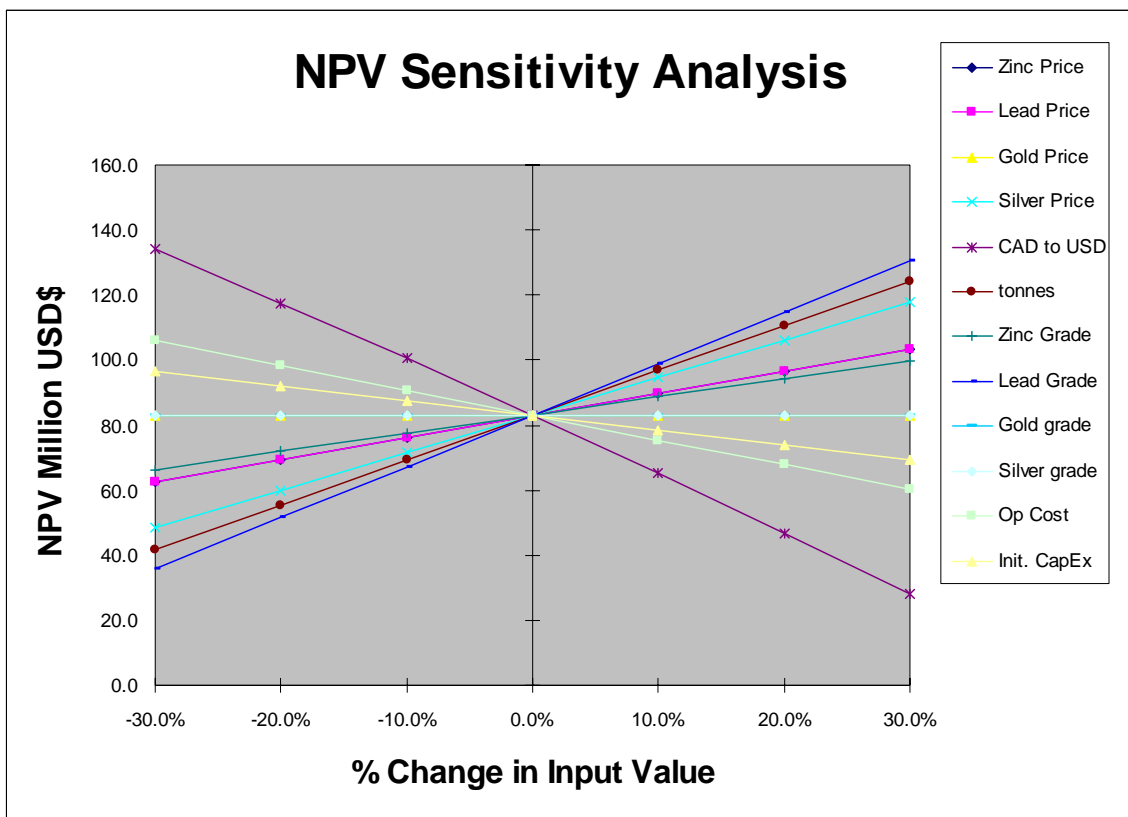

Figure 19.17: NPV Sensitivity Analysis

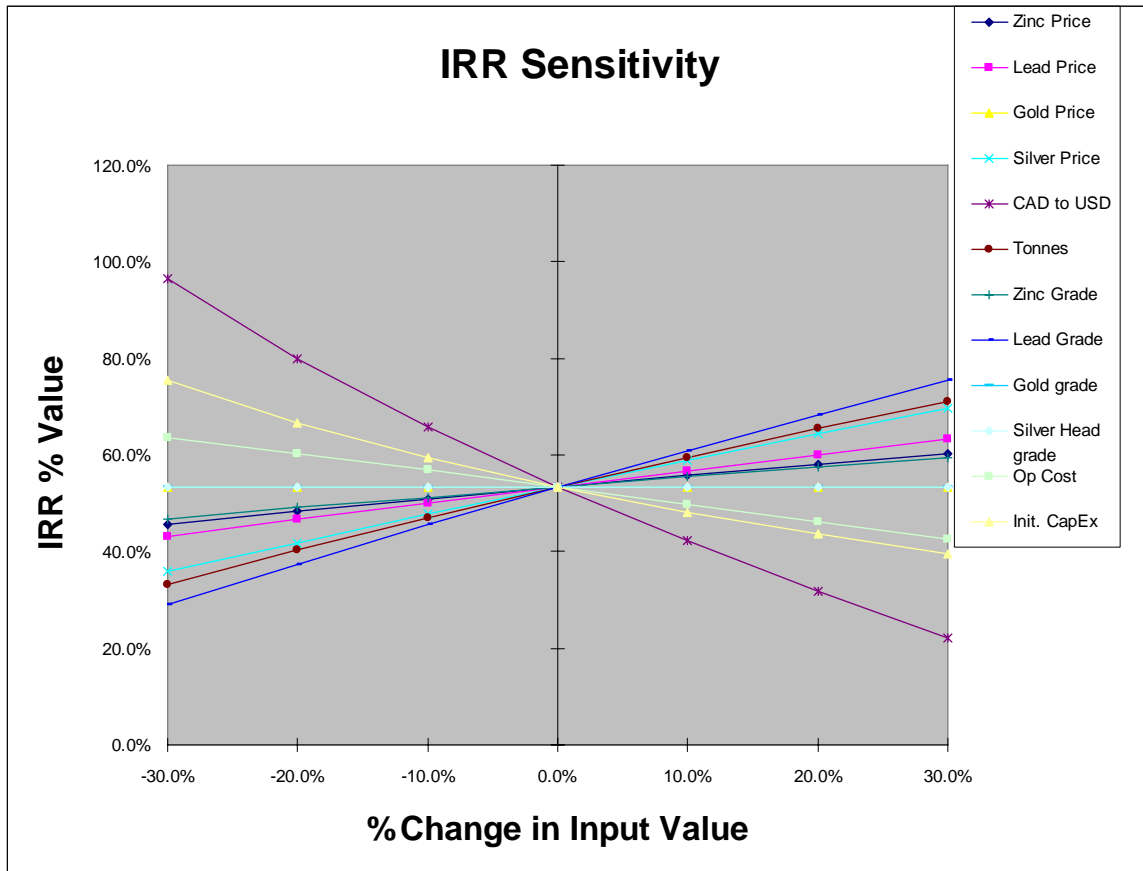

Figure 19.18: IRR Sensitivity Analysis

19.9 Payback

The payback period is defined as the time required after revenue is first received in Year 1 to achieve break-even cumulative cash flow. For this project, the payback period for the base case is 1.6 years. The payback period is based on the annual un-discounted cash flows. There is no consideration for inflation, interest, or depreciation in this calculation.

19.10 Mine Life

The mine life is estimated to be 5 years based on the currently defined inferred resources and adjusted for dilution. There is no guarantee that inferred mineral resources will be converted to indicated or measured resources required for the next level of study.

Exploration potential exists on the property both in the Bellekeno area and in other historical mining locations. The potential of these targets to increase mine life is not known at the present time.

20 Interpretations and Conclusions

20.1.1 Conclusions

Based on this preliminary economic assessment:

- The testwork results indicate that the tested mineralization responded well to the conventional lead/zinc differential flotation process with a cyanide-free zinc mineral suppression regime.
- Silver and lead minerals associate intimately and will be recovered together to produce a silver-lead bulk concentrate, and zinc minerals will be concentrated into a separate zinc concentrate.
- Narrow-vein mining methods will be applicable to the deposit with the final mining modalities based on geotechnical conditions.
- Providing that the set out design criteria and assumptions are satisfied, there is a strong indication that the project could be commercially viable.

20.1.2 Risks and Opportunities

Risks

There are normally a large number of risks associated with a mineral property at this level of development. Most of the risks come from a lack of data and further work on the property will add information that will better define the risks specific to Bellekeno and the ways the risks might be mitigated. Based on this study, the main Bellekeno project risks are estimated to be:

- Metal prices and exchange rates: The biggest risk to the project, as defined by the sensitivity analysis, is the US\$:C\$ exchange rate and metal prices.
- Permitting: A mining permit has not been granted for the project and is not guaranteed. A delay in permitting could delay the project schedule.
- Personnel: The timely recruitment of professional staff following a delay in permitting could be considered a risk, although support from contractors and consultants could reduce this risk.
- Mineral Resources: There is no guarantee the inferred resources currently estimated at Bellekeno will be able to be upgraded to an indicated or measured category.

- **Mining Dilution:** The mining dilution estimate in this report is based on industry best practice ground control, grade control and drill/blast operations. Failure to follow strict dilution-control practices could seriously impact the economic results of the project.

Opportunities

- **Exploration:** Additional resources from Bellekeno or other mineralized areas could be added to the project, if exploration work is successful.
- **Metal price:** Continued strong metal prices or a devaluing of the Canadian dollar versus the US dollar could offer a more favourable economic outcome. Using hedged of metal sales could reduce some of project risk but could also limit opportunities depending on the future, unpredictable price of metals.

21 Recommendations

It is recommended based on the preliminary positive results of this PEA that a feasibility study (PFS) be conducted on the Bellekeno Project.

The following general recommendations are required to carry the project to a feasibility level:

- Continue to develop underground access for drilling, bulk sampling and mining method testing
- Conduct a definition diamond drilling program to:
 - Upgrade the inferred mineral resources to an indicated or measured category. The current mineral resource estimate identified only inferred resources, which have no guarantee of being able to be upgraded to an indicated or measured classification.
 - Obtain improved metallurgical samples in areas not tested with a bulk sample.
 - Obtain improved geotechnical and groundwater information to allow more detailed review of dilution, mining methods, recovery, water inflows, etc.
- Conduct trial mining and bulk sampling in the main mineralized zones
- Conduct the following testwork on representative samples:
 - Metallurgy/mineral processing:
 - Optimize reagent scheme, primary grind size, and regrind size
 - Confirm cyanide-free reagent scheme for lead/zinc separation
 - Investigate of the metallurgical responses of various mineralization from various deposit zones to the developed flowsheet
 - Investigate the possibility of removing pyrite by flotation from the final tailings for backfill
 - Confirm the resistance to ball mill grinding.
 - Geotechnical
 - Laboratory testing of rock qualities
 - Hydrogeology
 - Pump and packer testing to provide input into a hydrogeological model both for underground water inflow and for well water production
- Upgrade all project engineering and costs estimation to a PFS level

The following recommendations apply to the mining of the access ramp and exploration drifts.

- Mining conditions in the SW zone are expected to be more adverse than those in the East zone. In certain areas the rockmass in the immediate vicinity of the mineralization zone HW is also of poor quality.
- Mining areas should be dewatered prior to stoping to avoid the compounding factor of large quantities of water along many of the veins. The presence of water in production areas will act as a lubricant, exacerbating poor ground conditions and have a negative impact on effectiveness and life time of the mining equipment.
- Access development should be maintained in the HW or FW to avoid adverse ground conditions in the mineralized zone. Multiple accesses will be required along the mineralization zone to generate shorter panel lengths. Bulk sampling panel lengths should be limited to a *maximum* of 25 m to either side of the access depending on ground conditions.

It is estimated that the cost to complete the necessary underground development and rehabilitation, drilling and sampling, testing and analysis and the compilation of a feasibility study will be approximately \$12M.

It is also recommended that exploration targets in the Bellekeno area be further explored to determine if additional mineralized zones could be added to the property resources.

22 Acronyms and Abbreviations

Distance	
µm	micron (micrometer)
mm	millimetre
cm	centimetre
m	meter
km	kilometre
"	inch
in	inch
'	foot
ft	foot
Area	
m ²	square meter
km ²	square kilometre
ac	acre
Ha	hectare
Volume	
l	litre
m ³	cubic meter
ft ³	cubic foot
usg	US gallon
lcm	loose cubic meter
bcm	bank cubic meter
Mbcm	Million bcm
Mass	
kg	kilogram
g	gram
t	metric tonne
Kt	Kilotonne
lb	pound
Mt	Megatonne
oz	troy ounce
wmt	wet metric tonne
dmt	dry metric tonne
Pressure	
psi	pounds per square inch
Pa	Pascal
kPa	kilopascal
MPa	megapascal
Elements and Compounds	
Au	gold
Ag	silver
Cu	copper
Hg	lead
Zn	zinc
CaCO ₃	Calcium carbonate
ANFO	Ammonium Nitrate/Fuel Oil

Other	
°C	degree Celsius
°F	degree Fahrenheit
Btu	British thermal unit
cfm	cubic feet per minute
elev	elevation above sea level
masl	metres above sea level
hp	horsepower
hr	hour
kW	kilowatt
kWh	kilowatt hour
M	Million
mph	miles per hour
ppb	parts per billion
ppm	parts per million
s	second
s.g.	specific gravity
usgpm	US gallon per minute
V	volt
W	watt
Ω	ohm
A	ampere
tph	tonnes per hour
tpd	tonnes per day
Ø	diameter
Acronyms	
SRK	SRK Consulting (Canada) Inc.
CIM	Canadian Institute of Mining
NI 43-101	National Instrument 43-101
AML	Acidic and/or Metal Leaching
Conversion Factors	
1 tonne	2,204.62 lb
1 oz	31.1035 g

23 References

- Franklin, R. 2007. *Whistler Project Synopsis*. Kennecott Exploration Company, unpublished internal report. 52 pages.
- Cathro, R.J. (2006) *The History and Geology of the Keno Hill Silver Camp, Yukon Territory*, Geoscience Canada, v. 33, No. 3, 103 – 134
- Dusel-Bacon, C., Lanphere, M.A., Sharp, W.D., Layer, P.W., and Hansen, V.L. (2002) *Mesozoic thermal history and timing of structural events for the Yukon–Tanana Upland, east-central Alaska: ⁴⁰Ar/³⁹Ar data from metamorphic and plutonic rocks*, Can. J. Earth Sci. 39: 1013–1051
- Lynch, J.V.G. (1989) *Large-scale hydrothermal zoning reflected in the tetrahedrite-freibergite solid solution, Keno Hill Ag-Pb-Zn district, Yukon*, Canadian Mineralogist, v. 27, p. 383-400.
- Murphy, D. C. (1997) *Geology of the McQueston River Region, Northern McQueston and Mayo Map Areas, Yukon Territory (115P/14, 15, 16/105M/13, 14)*, Exploration and Geological Services Division, Yukon, Indian and Northern Affairs Canada, Bulletin 6, 122 p.
- Roots, C.F. (1997) *Geology of the Mayo Map Area, Yukon Territory (105M)*, Geological Survey of Canada, Bulletin 7, 82 p.
- Sack, R.O., Lynch, J.V.G., and Foit, Jr, F.(2003) *Fahlore as a petrogenetic indicator, Keno Hill Ag-Pb-Zn district, Yukon, Canada*, Mineralogical Magazine, v. 67, p.1023-1038.
- SRK Consulting (Canada) Inc. 2007. *Mineral Resource Estimation, Bellekeno Project, Yukon Territory, Canada*, Independent technical report prepared for Alexco Resource Corporation and filed on SEDAR (www.sedar.com), 108 pages

24 Date and Signature Page

The effective date of this report is June 30, 2008. This report was compiled by:

Original signed and stamped

David Keller, P.Geo. SRK

Date

Josef Sedlacek, P.Eng. SRK

Date

Gordon Doerksen, P.Eng. SRK

Date

Hassan Ghaffari, P.Eng. Wardrop

Date

Diane Lister, P. Eng. Altura

Date

25 Illustrations

There are no additional illustrations.

CERTIFICATE of AUTHOR

I, Hassan Ghaffari, do hereby certify that:

1. I am a Manager of Metallurgy with the firm of Wardrop Engineering Inc. with an office at Suite 800, 555 West Hastings St., Vancouver, BC, V6B 1M1;
2. I am a graduate of the University of Tehran with a M.A.Sc. in Mining Engineering (1998) and the University of British Columbia with a M.A.Sc. in Mineral Process Engineering (2004). I have practiced my profession continuously since 1998;
3. I am a member in good standing of the Association of Professional Engineers and Geoscientists of the Province of British Columbia (#30408);
4. I have not received, nor do I expect to receive, any interest, directly or indirectly, in the subject property or securities of Alexco Resource Corp;
5. That, as of the date of this certificate, to the best of my knowledge, information and belief, this technical report contains all scientific and technical information that is required to be disclosed to make the technical report not misleading;
6. I have read National Instrument 43-101 and Form 43-101F1 and I am a Qualified Person for the purpose of NI 43-101 and this technical report has been prepared in compliance with National Instrument 43-101 and Form 43-101F1;
7. I, as the qualified person, am independent of the issuer as defined in Section 1.4 of National Instrument 43-101;
8. I visited the Bellekeno project site on March 31 to April 2, 2008.
9. I have had no prior involvement with the Bellekeno Project.
10. I am not aware of any material fact or material change with respect to the subject matter of the Preliminary Economic Assessment ("PEA") that is not reflected in the PEA, the omission to disclose which makes the PEA misleading.
11. I consent to the filing of the PEA with any stock exchange and other regulatory authority and any publication by them for regulatory purposes, including electronic publication in the public company files on their websites accessible by the public, of the PEA.
12. I am responsible for Sections 16, 19.2, 19.6, 19.8, 19.9 and parts of 19.7 of this report entitled "Bellekeno Preliminary Economic Assessment Technical Report" dated June 30, 2008 ("Technical Report").

ORIGINAL SIGNED AND STAMPED

555 West Hastings Street, Suite 800
Vancouver, British Columbia V6B 1M1
Canada
Phone: 604-408-3788
Fax: 604-408-3722
E-mail: vancouver@wardrop.com
Internet: www.wardrop.com



Diane Lister, P.Eng.
18 Michie Place, Marsh Lake, Yukon Y0B 1Y2

CERTIFICATE of AUTHOR

I, Diane Lister, do hereby certify that:

- 1) I am a consulting environmental engineer and principal of Altura Environmental Consulting with a business address at 18 Michie Place, Marsh Lake, Yukon.;
- 2) I am a graduate of the University of British Columbia (B.A.Sc. Geological Engineering, 1989, M.A.Sc. Mining Engineering, 1994). I have practiced my profession continuously since graduation in 1994;
- 3) I am a Professional Environmental Engineer and member in good standing with the Association of Professional Engineers and Geoscientists of British Columbia (License #25689) and the Association of Professional Engineers of Yukon (License #1552);
- 4) I have not received, nor do I expect to receive, any interest, directly or indirectly, in the subject property or securities of Alexco Resource Corp;
- 5) That, as of the date of this certificate, to the best of my knowledge, information and belief, this technical report contains all scientific and technical information that is required to be disclosed to make the technical report not misleading;
- 6) I have read National Instrument 43-101 and Form 43-101F1 and I am a Qualified Person for the purpose of NI 43-101 and this technical report has been prepared in compliance with National Instrument 43-101 and Form 43-101F1;
- 7) I, as the qualified person, am independent of the issuer as defined in Section 1.4 of National Instrument 43-101;
- 8) I visited the Bellekeno project site on February 27 and 28, 2008.
- 9) I have had prior involvement with the Bellekeno Project. I was retained by Alexco Resource Corp. in November 2007 to assist with development of the Bellekeno Waste Rock Management Plan and assist in compilation of permit application documentation, and continue to provide ongoing consulting services to the project.
- 10) I am not aware of any material fact or material change with respect to the subject matter of the Preliminary Economic Assessment ("PEA") that is not reflected in the PEA, the omission to disclose which makes the PEA misleading.
- 11) I consent to the filing of the Preliminary Economic Assessment with any stock exchange and other regulatory authority and any publication by them for regulatory purposes, including electronic publication in the public company files on their websites accessible by the public, of the Pre-feasibility Report.
- 12) I am responsible for Section 19.5 Environmental Considerations of this report entitled "Bellekeno Preliminary Economic Assessment Technical Report" dated June 30, 2008 ("Technical Report").

ORIGINAL SIGNED AND STAMPED

CERTIFICATE of AUTHOR

I, Gordon Doerksen, do hereby certify that:

- 1) I am a Principal Consultant - Mining with SRK Consulting (Canada) Inc.;
- 2) I am a graduate of Montana College of Mineral Science and Technology with a BS degree in Mining Engineering (1990). I have practiced my profession continuously since graduation;
- 3) I am a Professional Engineer (Mining) in good standing in British Columbia (#32273);
- 4) I am a member of the Canadian Institute of Mining and a Founding Registered Member of the Society of Mining Engineers of the AIME;
- 5) I have not received, nor do I expect to receive, any interest, directly or indirectly, in the subject property or securities of Alexco Resource Corp;
- 6) As of the date of this certificate, to the best of my knowledge, information and belief, this technical report contains all scientific and technical information that is required to be disclosed to make the technical report not misleading;
- 7) I have read National Instrument 43-101 and Form 43-101F1 and I am a Qualified Person for the purpose of NI 43-101 and this technical report has been prepared in compliance with National Instrument 43-101 and Form 43-101F1;
- 8) I, as the qualified person, am independent of the issuer as defined in Section 1.4 of National Instrument 43-101;
- 9) I visited the Bellekeno project site on January 28 and 29, 2008.
- 10) I am not aware of any material fact or material change with respect to the subject matter of the Preliminary Economic Assessment (“PEA”) that is not reflected in the PEA, the omission to disclose which makes the PEA misleading.
- 11) I consent to the filing of the PEA Study with any stock exchange and other regulatory authority and any publication by them for regulatory purposes, including electronic publication in the public company files on their websites accessible by the public, of the PEA.
- 12) I am responsible for the overall compilation of the report “Bellekeno Preliminary Economic Assessment Technical Report” dated June 30, 2008 (“Technical Report”) and for all Sections of the report not signed-off by the other QPs.

ORIGINAL SIGNED AND STAMPED

QP Letter - Bellekeno.doc



Group Offices:

Africa
Asia
Australia
Europe
North America
South America

Canadian Offices:

Saskatoon 306.955.4778
Sudbury 705.682.3270
Toronto 416.601.1445
Vancouver 604.681.4196
Yellowknife 867.445.8670

U.S. Offices:

Anchorage 907.677.3520
Denver 303.985.1333
Elko 775.753.4151
Fort Collins 970.407.8302
Reno 775.828.6800
Tucson 520.544.3688

CERTIFICATE of AUTHOR

I, Josef Sedlacek, do hereby certify that:

- 1) I am a Principal Consultant with the firm of SRK Consulting (Canada) Inc. with an office at Suite 2200-1066 West Hastings Street, Vancouver, Canada;
- 2) I am a graduate of the Mining University of Ostrava, Czech Republic with a Masters Degree in Mine Engineering. I have practiced my profession most of the time since 1964;
- 3) I am a Professional in good standing in the Province of Ontario #41407016;
- 4) I have not received, nor do I expect to receive, any interest, directly or indirectly, in the subject property or securities of Alexco Resource Corp;
- 5) That, as of the date of this certificate, to the best of my knowledge, information and belief, this technical report contains all scientific and technical information that is required to be disclosed to make the technical report not misleading;
- 6) I have read National Instrument 43-101 and Form 43-101F1 and I am a Qualified Person for the purpose of NI 43-101 and this technical report has been prepared in compliance with National Instrument 43-101 and Form 43-101F1;
- 7) I, as the qualified person, am independent of the issuer as defined in Section 1.4 of National Instrument 43-101;
- 8) I have not had prior involvement with the Bellekeno Project.
- 9) I am not aware of any material fact or material change with respect to the subject matter of the Preliminary Economic Assessment (“PEA”) that is not reflected in the PEA, the omission to disclose which makes the PEA misleading.
- 10) I consent to the filing of the Pre-feasibility Study with any stock exchange and other regulatory authority and any publication by them for regulatory purposes, including electronic publication in the public company files on their websites accessible by the public, of the Pre-feasibility Report.
- 11) I am in part responsible for Sections 1, 2, 3, 18, 19, 20 and 21 of this report entitled “Bellekeno Preliminary Economic Assessment Technical Report” dated June 30, 2008 (“Technical Report”).

ORIGINAL SIGNED AND STAMPED

Josef Sedlacek

2008-07-08
Vancouver, BC, Canada

CERTIFICATE of AUTHOR

I, G. David Keller, do hereby certify that:

- 1) I am a Principal Resource Geologist with the firm of SRK Consulting (Canada) Inc. with an office at 1000 25 Adelaide Street East, Toronto, Ontario;
- 2) I am a graduate of the University of Alberta with a B. Sc, 1986. I have practiced my profession continuously since 1986;
- 3) I am a Professional Geologist in good standing in the Ontario (#1235);
- 4) I am a member of the Association of Professional Geoscientists of Ontario;
- 5) I have not received, nor do I expect to receive, any interest, directly or indirectly, in the subject property or securities of Alexco Resource Corp;
- 6) That, as of the date of this certificate, to the best of my knowledge, information and belief, this technical report contains all scientific and technical information that is required to be disclosed to make the technical report not misleading;
- 7) I have read National Instrument 43-101 and Form 43-101F1 and I am a Qualified Person for the purpose of NI 43-101 and this technical report has been prepared in compliance with National Instrument 43-101 and Form 43-101F1;
- 8) I, as the qualified person, am independent of the issuer as defined in Section 1.4 of National Instrument 43-101;
- 9) I visited the Bellekeno project site on March 22 to 23, 2005 and August 30 to September 6, 2007.
- 10) I am not aware of any material fact or material change with respect to the subject matter of the Preliminary Economic Assessment (“PEA”) that is not reflected in the PEA, the omission to disclose which makes the PEA misleading.
- 11) I consent to the filing of the PEA with any stock exchange and other regulatory authority and any publication by them for regulatory purposes, including electronic publication in the public company files on their websites accessible by the public, of the Pre-feasibility Report.
- 12) I am responsible for Section 17.1 to 17.4 of this report entitled “Bellekeno Preliminary Economic Assessment Technical Report” dated June 30, 2008 (“Technical Report”).

ORIGINAL SIGNED AND STAMPED

APPENDIX A

Cash Flow Models (Wardrop)

Instructions

GLOSSARY							
dmt	dry metric tonne						
wmt	wet metric tonne (includes moisture in concentrate)						
acc	accountable						
NIV	Net Invoice Value - Gross Value less Treatment Terms						
NSR	Net Smelter Return - Net Invoice Value less Transportation Costs, Losses, Insurance, and Representation						
STANDARD CONVERSIONS							
22.046	% grade to pounds	34.2857	1 Oz/Short Ton= 34.2857 gpt				
2.2046	pounds per kg	0.9071847	Short Tons to Tonnes				
31.10352	grams per ounce						
METAL PRICE FOR MODEL		as of 4/9/2008	LME Cash Price official				
as at 9 April 2008 from LME (www.metalprices.com)							
	Current - July 2, 2008	2 yr Average	3 yr Average	4yr Average	5 yr Average	Forecast	Unit
Zinc Price	0.84	1.49	1.24	1.06	0.93	1.00	USD\$/lb
Lead	0.7802	0.9831	0.8125	0.7148	0.6278		USD\$/lb
Gold Price	935.25	699.42	625.59	572.73	533.95	500.00	USD\$/oz
Silver Price	17.92	13.51	11.69	10.45	9.45	10.00	USD\$/oz
Exchange Rate	0.99	0.92	0.89	0.86	0.83	0.85	source : Bank of Canda
Assumptions and Comments :							
- As per Alexco: Royalties are 1.5% NSR after All initial Capital Paid Back and Accumulated CF turns positive and Capped at \$ 4M CAD							
- Resources as per SRK Report							
- Mining Operating costs as per SRK							
- Capital costs as per SRK							
- SW+ 99 Zone and East zone each have their own evaluation model. The East Zone's Cash Flow is added to SW+99 Model							
- NPV and IRR for both projects is calculated in the SW+99 Zone							
- Penalties and Payabilities to be reviewed and finalized ; estimates only							
- Mining, site, and exploration Capital Costs and expenditures to be reviewed and finalized; estimates only							
- Gold and Silver Grade in Concentrate as per Client Feasibility Report							
- Working Capital is reversed on year 5							
- Depreciation Costs not Calculated							
- Concentrate grades and metal recoveries are related to feed grades but the model does not provide clear connection to the relationship between the head grade and metal recoveries due to using the fixed average head grades.							
- The model is calculated based on concentrate grades from carried out locked cycle metallurgical test works.							

WARDROP

Client		Alexco										
Project		Bellekeno										
Version		006										
Version Date		7-Jul-08										
			3 YEAR AVERAGE PRICES									
			Source	Units	Y-2	Y-1	Y1	Y2	Y3	Y4	Y5	TOTAL
					2008	2009	2010	2011	2012	2013	2014	
Metal Prices												
	Zinc		LME	US\$/lb			1.24	1.24	1.24	1.24	1.24	
	Gold		LME	US\$/oz			625.59	625.59	625.59	625.59	625.59	
	Lead		LME	US\$/lb			0.81	0.81	0.81	0.81	0.81	
	Silver		LME	US\$/oz			11.69	11.69	11.69	11.69	11.69	
Mining Production												
	Tonnes Ore Mined & Milled SW+99			000's tonnes			91	91	91	91	44	409
	Combined Ore Mined & Milled SW+99 & East Zone			000's tonnes			91	91	146	146	139	614
	Lead Grade			%			16.6%	16.6%	16.6%	16.6%	16.6%	
	Zinc Grade			%			4.90%	4.90%	4.90%	4.90%	4.90%	
	Gold Grade			g/t			0.220	0.220	0.220	0.220	0.220	
	Silver Grade			g/t			1221.36	1221.36	1221.36	1221.36	1221.36	
Lead Concentrate												
	Tonnage			dmt			20,302	20,302	20,302	20,302	9,734	90,941
Concentrate Grade												
	Zinc			%			1.50%	1.50%	1.50%	1.50%	1.50%	
	Lead			%			72.00%	72.00%	72.00%	72.00%	72.00%	
	Silver			g/t			4782.929	4782.929	4782.929	4782.929	4782.929	
Metallurgical Recovery												
	Lead			%			96.50%	96.50%	96.50%	96.50%	96.50%	
	Silver			%			87.10%	87.10%	87.10%	87.10%	87.10%	
Recovered Metal												
	Lead			million lb			32.2	32.2	32.2	32.2	15.5	
	Silver			oz			3,121,908	3,121,908	3,121,908	3,121,908	1,496,840	13,984,474
Accountable Metal												
	Lead			million lb			30.6	30.6	30.6	30.6	14.7	
	Silver			oz			2,809,717.6	2,809,717.6	2,809,717.6	2,809,717.6	1,347,155.7	12,586,026
Gross Revenue by Metal												
	Lead			000's US\$			\$24,874	\$24,874	\$24,874	\$24,874	\$11,926	
	Silver			000's US\$			\$32,848	\$32,848	\$32,848	\$32,848	\$15,750	
	Total Lead Gross Revenue		W	000's US\$		\$0	\$57,941	\$57,941	\$57,941	\$57,941	\$27,780	259,543
Zinc Concentrate												
	Tonnage			dmt			7,756	7,756	7,756	7,756	3,719	34,742
Concentrate Grade												
	Zinc			%			52.00%	52.00%	52.00%	52.00%	52.00%	
	Silver			g/t			1158.529	1158.529	1158.529	1158.529	1158.529	
Metallurgical Recovery												
	Zinc			%			90.20%	90.20%	90.20%	90.20%	90.20%	
	Silver			%			8.00%	8.00%	8.00%	8.00%	8.00%	
Recovered Metal												
	Zinc			million lb			8.9	8.9	8.9	8.9	4.3	39.8
	Silver			oz			288,888	288,888	288,888	288,888	138,511	1,294,063
Accountable Metal												
	Zinc			million lb			7.6	7.6	7.6	7.6	3.6	33.9
	Silver			oz			187,777	187,777	187,777	187,777	90,032	841,141
Gross Revenue by Metal												
	Zinc			000's US\$			\$9,364	\$9,364	\$9,364	\$9,364	\$4,490	41,945
	Silver			000's US\$			\$2,195	\$2,195	\$2,195	\$2,195	\$1,053	9,834
	Total Zinc Gross Revenue		W	000's US\$		\$0	\$11,643	\$11,643	\$11,643	\$11,643	\$5,582	52,152

	Source	Units	Y-2	Y-1	Y1	Y2	Y3	Y4	Y5	TOTAL
Zinc Concentrate										
Total Zinc		000's US\$			\$9,364	\$9,364	\$9,364	\$9,364	\$4,490	41,945
Total Lead		000's US\$			\$24,874	\$24,874	\$24,874	\$24,874	\$11,926	111,422
Total Silver		000's US\$			\$35,044	\$35,044	\$35,044	\$35,044	\$16,802	156,977
Total Gross Revenue		000's US\$	\$0	\$0	\$69,583	\$69,583	\$69,583	\$69,583	\$33,363	311,696
Lead Concentrate										
Smelting & Refining & Price Participation		000's US\$			\$5,906	\$5,906	\$5,906	\$5,906	\$2,832	
Metal Penalties		000's US\$			\$149	\$149	\$149	\$149	\$72	
Transportation		000's US\$			\$3,590	\$3,590	\$3,590	\$3,590	\$1,721	
Total		000's US\$			\$9,645	\$9,645	\$9,645	\$9,645	\$4,624	43,204
Lead Net Smelter Return	W	000's US\$			\$48,296	\$48,296	\$48,296	\$48,296	\$23,156	216,339
Zinc Concentrate										
Smelting & Refining & Price Participation		000's US\$			\$2,542	\$2,542	\$2,542	\$2,542	\$1,219	
Metal Penalties		000's US\$			\$28	\$28	\$28	\$28	\$13	
Transportation		000's US\$			\$1,371	\$1,371	\$1,371	\$1,371	\$658	
Total		000's US\$	\$0	\$0	\$3,941	\$3,941	\$3,941	\$3,941	\$1,890	17,655
Zinc Net Smelter Return	W	000's US\$	\$0	\$0	\$7,701	\$7,701	\$7,701	\$7,701	\$3,692	34,497
Lead and Zinc Concentrate										
Smelting & Refining & Price Participation		000's US\$			\$8,448	\$8,448	\$8,448	\$8,448	\$4,050	37,841
Metal Penalties		000's US\$			\$177	\$177	\$177	\$177	\$85	793
Transportation		000's US\$			\$4,961	\$4,961	\$4,961	\$4,961	\$2,379	22,225
Total		000's US\$	\$0	\$0	\$13,586	\$13,586	\$13,586	\$13,586	\$6,514	60,859
Net Revenue by Metal										
Total Zinc		000's US\$			\$6,099	\$6,099	\$6,099	\$6,099	\$2,924	27,320
Total Lead		000's US\$			\$20,035	\$20,035	\$20,035	\$20,035	\$9,606	89,745
Total Silver		000's US\$			\$29,760	\$29,760	\$29,760	\$29,760	\$14,269	133,310
Net Revenue		000's US\$	\$0	\$0	\$55,894	\$55,894	\$55,894	\$55,894	\$26,799	250,375
1.5% NSR Royalty Capped at \$4M Royalty Begins when Cumulative CF starts positive										
Royalty Payments SW+99 Zone	AL	000's US\$	\$0	\$0	\$0	\$277	\$838	\$838	\$402	2,356
Royalty Payments East Zone	AL	000's US\$			\$0	\$0	\$273	\$273	\$476	
Operating Cost -SW+99 Zones										
Underground Mining		000's CAD\$			\$10,170	\$12,044	\$10,990	\$10,240	\$4,978	48,422
Milling		000's CAD\$			\$5,901	\$5,901	\$4,189	\$4,189	\$2,009	22,189
General & Administration		000's CAD\$			\$3,370	\$3,370	\$2,106	\$2,106	\$1,057	12,009
SubTotal Operating Cost - SW+99 Zones	SRK + W	000's CAD\$			\$19,441	\$21,315	\$17,285	\$16,535	\$8,044	
SubTotal Operating Cost - SW+99 Zones	SRK + W	000's US\$	\$0	\$0	\$17,337	\$19,008	\$15,415	\$14,746	\$7,173	73,679
Capital Costs - All Zones										
Pre-production Capital	SRK+ W	000's US\$	\$11,147	\$40,714						51,861
Working Capital		000's US\$			\$4,334	\$0	\$0	\$0	(\$4,334)	0
Sustaining Capital										
Exploration Development		000's CAD\$	\$0	\$1,320	\$1,360	\$2,680	\$2,680	\$0	\$0	8,040
Mine Development		000's CAD\$	\$0	\$0	\$0	\$0	\$0	\$0	\$0	0
Mine Equipment		000's CAD\$	\$0	\$0	\$1,020	\$2,780	\$676	\$0	\$0	4,476
Closure and Salvage costs at Mine End		000's CAD\$	\$0	\$500	\$250	\$250	\$250	\$250	\$250	1,750
SubTotal Sustaining Capital	SRK + W	000's CAD\$	\$0	\$1,820	\$2,630	\$5,710	\$3,606	\$250	\$250	
SubTotal Sustaining Capital	SRK + W	000's US\$	\$0	\$1,623	\$2,345	\$5,092	\$3,216	\$223	\$223	12,722
Total Capital Cost - All Zones	SRK + W	000's US\$	11,147	40,714	6,680	5,092	3,216	223	-4,111	62,961
Summary SW + 99										
Net Revenue		000's US\$	0	0	55,894	55,894	55,894	55,894	26,799	250,375
Royalty Payments		000's US\$	0	0	0	277	838	838	402	2,356

Pre-Tax DCF

	Source	Units	Y-2	Y-1	Y1	Y2	Y3	Y4	Y5	TOTAL
Operating Cost		000's US\$	0	0	17,337	19,008	15,415	14,746	7,173	73,679
Capital Costs		000's US\$	11,147	40,714	6,680	5,092	3,216	223	-4,111	62,961
Summary East Zone										
Net Revenue		000's US\$	0	0	0	0	18,173	18,173	31,766	68,112
Royalty Payments		000's US\$	0	0	0	0	273	273	476	1,022
Operating Cost		000's US\$	0	0	0	0	9,249	8,848	15,691	33,788
Summary All Zones										
Net Revenue		000's US\$	0	0	55,894	55,894	74,067	74,067	58,565	318,487
Royalty Payments		000's US\$	0	0	0	277	1,111	1,111	878	3,378
Operating Costs		000's US\$	0	0	17,337	19,008	24,664	23,594	22,864	107,467
Capital Costs Pre-Production and Sustaining		000's US\$	11,147	40,714	6,680	5,092	3,216	223	-4,111	62,961
Pre-Tax Cash Flow - All Zones										
Cash Flow From SW+ 99 and East Zones		000's US\$	-11,147	-40,714	31,877	31,516	44,804	48,867	38,458	143,660
Cash Flow From SW+ 99 and East Zones		000's CAD\$	-12,500	-45,655	35,746	35,341	50,241	54,797	43,124	161,093
Accumulated Cash Flow From SW+ 99 and East Zones		000's US\$	-11,147	-51,861	-19,984	11,532	56,336	105,202	143,660	233,737
Discounted Cash Flow		000's US\$	-10,322	-34,906	25,305	23,165	30,493	30,794	22,440	86,970
Accumulated Discounted Cash Flow		000's US\$	-10,322	-45,227	-19,922	3,243	33,736	64,530	86,970	
NSR										
NSR All Zones per Tonne		CAD/ Tonne Ore			\$ 687	\$ 687	\$ 569	\$ 569	\$ 471	LOM Average \$ 596
Cost per Tonne		CAD/ Tonne Ore			\$ 213	\$ 237	\$ 198	\$ 190	\$ 191	\$ 206
Operating Margin per Tonne		CAD/ Tonne Ore			\$ 474	\$ 450	\$ 371	\$ 379	\$ 280	\$ 391
Discount Rate										
		%	8.0%							
Pre-Income Tax Net Present Value (NPV)										
		Million USD\$	87.0							
Pre-Income Tax Net Present Value (NPV)										
		Million CAD\$	97.5							
Pre-Income Tax Internal Rate of Return (IRR)										
		%	55.5%							
Initial Capital										
		million Cdn\$	51.9							
Average Operating Cost LOM										
		Cdn\$/t	200.23							
Mine Life										
		Yrs	5.0							
Payback Period										
		Yrs	1.6							
Legend										
W - Wardrop										
LME - London Metal Exchange										
AL- Alexco Resources										
SRK - SRK Consulting										

Input

				Units		Input	Year -2	Year -1	Year 1	Year 2	Year 3	Year 4	Year 5
x		Silver		%		90.00			90.00	90.00	90.00	90.00	90.00
		Silver in Zinc		%		65.00			65.00	65.00	65.00	65.00	65.00
		TREATMENT TERMS											
		Lead Concentrate											
x		Smelting		US\$/dmt		\$140.00			140.00	140.00	140.00	140.00	140.00
		Refining											
x		Zinc		US\$/acc lb		\$0.000			\$0.000	\$0.000	\$0.000	\$0.000	\$0.000
x		Lead				\$0.000			\$0.000	\$0.000	\$0.000	\$0.000	\$0.000
x		Gold		US\$/acc oz		\$6.000			\$6.000	\$6.000	\$6.000	\$6.000	\$6.000
x		Silver		US\$/acc oz		\$0.350			\$0.350	\$0.350	\$0.350	\$0.350	\$0.350
x		Price Escalation				15.0%			15.0%	15.0%	15.0%	15.0%	15.0%
x		Base Price \$US/lb				\$0.36			0.36	0.36	0.36	0.36	0.36
		Zinc Concentrate											
x		Smelting		US\$/dmt		\$225.00			225.00	225.00	225.00	225.00	225.00
		Refining											
x		Zinc		US\$/acc lb		\$0.000			\$0.000	\$0.000	\$0.000	\$0.000	\$0.000
x		Gold		US\$/acc oz		\$5.000			\$5.000	\$5.000	\$5.000	\$5.000	\$5.000
x		Silver		US\$/acc oz		\$0.400			\$0.400	\$0.400	\$0.400	\$0.400	\$0.400
x		Price Escalation (above base)				16.0%			16.0%	16.0%	16.0%	16.0%	16.0%
x		Price Escalation (below base)				13.0%			13.0%	13.0%	13.0%	13.0%	13.0%
x		Base Zinc Price \$US/lb				\$0.635			0.64	0.64	0.64	0.64	0.64
		Net Smelter Return (NSR)											
		TRANSPORTATION											
x		Mine to Port		Cdn\$/wmt		\$181.86			181.86	181.86	181.86	181.86	181.86
x		Storage and Vessel Loading		Cdn\$/wmt		\$0.00			-	-	-	-	-
		Land + Ocean Freight		US\$/wmt		\$0.00			-	-	-	-	-
x		Representation		US\$/wmt		\$0.50			0.50	0.50	0.50	0.50	0.50
x		Insurance		% NIV		0.15%			0.15%	0.15%	0.15%	0.15%	0.15%
x		Losses		% NIV		0.50%			0.50%	0.50%	0.50%	0.50%	0.50%
x		Moisture		%		8%			8.0%	8.0%	8.0%	8.0%	8.0%
		Penalties											
		Lead Concentrate Penalties - Lakefield											
x		Antimony	Penalty Charge	US\$/dmt		\$ 1.50			\$1.50	\$1.50	\$1.50	\$1.50	\$1.50
x			Grade in Concentration	ppm		5900			5900	5900	5900	5900	5900
x			Penalty Increment	ppm		1000			1000	1000	1000	1000	1000
x			Threshold	ppm		1000			1000	1000	1000	1000	1000
x		Arsenic	Penalty Charge	US\$/dmt		\$ 1.50			\$1.50	\$1.50	\$1.50	\$1.50	\$1.50
x			Grade in Concentration	ppm		270			270	270	270	270	270
x			Penalty Increment	ppm		1000.0			1000	1000	1000	1000	1000
x			Threshold	ppm		5000.0			5000	5000	5000	5000	5000
x		Lead	Penalty Charge	US\$/dmt		\$ -			\$0.00	\$0.00	\$0.00	\$0.00	\$0.00

Input

				Units		Input	Year -2	Year -1	Year 1	Year 2	Year 3	Year 4	Year 5
x			Grade in Concentration	%		0.00%			0.00%	0.00%	0.00%	0.00%	0.00%
x			Penalty Increment	%		0%			0%	0%	0%	0%	0%
x			Threshold	%		0%			0%	0%	0%	0%	0%
x		Mercury	Penalty Charge	US\$/dmt		\$ 1.00			\$1.00	\$1.00	\$1.00	\$1.00	\$1.00
x			Grade in Concentration	ppm		2			2	2	2	2	2
x			Penalty Increment	ppm		10			10	10	10	10	10
x			Threshold	ppm		50			50	50	50	50	50
x		Selenium	Penalty Charge	US\$/dmt	No Data	\$ -			\$0.00	\$0.00	\$0.00	\$0.00	\$0.00
x			Grade in Concentration	ppm		30			30	30	30	30	30
x			Penalty Increment	ppm		1			1	1	1	1	1
x			Threshold	ppm		0			0	0	0	0	0
x		Zinc	Penalty Charge	US\$/dmt		\$ 1.00			\$1.00	\$1.00	\$1.00	\$1.00	\$1.00
x			Grade in Concentration	%		4.87%			4.87%	4.87%	4.87%	4.87%	4.87%
x			Penalty Increment	%		1%			1%	1%	1%	1%	1%
x			Threshold	%		8%			8%	8%	8%	8%	8%
			Zinc Concentrate Penalties - Lakefield										
x		Antimony	Penalty Charge	US\$/dmt		\$ 3.00			\$3.00	\$3.00	\$3.00	\$3.00	\$3.00
x			Grade in Concentration	ppm		680			680	680	680	680	680
x			Penalty Increment	ppm		1000			1000	1000	1000	1000	1000
x			Threshold	ppm		1000			1000	1000	1000	1000	1000
x		Arsenic	Penalty Charge	US\$/dmt		\$ 2.00			\$2.00	\$2.00	\$2.00	\$2.00	\$2.00
x			Grade in Concentration	ppm		140			140	140	140	140	140
x			Penalty Increment	ppm		1000			1000	1000	1000	1000	1000
x			Threshold	ppm		1000			1000	1000	1000	1000	1000
x		Cadmium	Penalty Charge	US\$/dmt		\$ 1.00			\$1.00	\$1.00	\$1.00	\$1.00	\$1.00
x			Grade in Concentration	ppm		6600			6600	6600	6600	6600	6600
x			Penalty Increment	ppm	Assume	1000			1000	1000	1000	1000	1000
x			Threshold	ppm		3000			3000	3000	3000	3000	3000
x		Fluorine	Penalty Charge	US\$/dmt		1			\$1.00	\$1.00	\$1.00	\$1.00	\$1.00
x			Grade in Concentration	ppm		50			50	50	50	50	50
x			Penalty Increment	ppm		120			120	120	120	120	120
x			Threshold	ppm		150			150	150	150	150	150
x		Iron	Penalty Charge	US\$/dmt		\$ 1.50			\$1.50	\$1.50	\$1.50	\$1.50	\$1.50
x			Grade in Concentration	%		8.00%			8.00%	8.00%	8.00%	8.00%	8.00%
x			Penalty Increment	%		1%			1%	1%	1%	1%	1%
x			Threshold	%		8.00%			8%	8%	8%	8%	8%
x		Mercury	Penalty Charge	US\$/dmt		\$ 3.50			\$3.50	\$3.50	\$3.50	\$3.50	\$3.50
x			Grade in Concentration	ppm		13			13	13	13	13	13
x			Penalty Increment	ppm		125			125	125	125	125	125
x			Threshold	ppm		30			30	30	30	30	30
x			Penalty Charge	US\$/dmt		\$ 4.25			\$4.25	\$4.25	\$4.25	\$4.25	\$4.25

Input

			Units		Input	Year -2	Year -1	Year 1	Year 2	Year 3	Year 4	Year 5
			Grade in Concentration	ppm	Assume	13		13	13	13	13	13
x			Penalty Increment	ppm		55		55	55	55	55	55
x			Threshold	ppm		100		100	100	100	100	100
x		Selenium	Penalty Charge	US\$/dmt	\$	1.00		\$1.00	\$1.00	\$1.00	\$1.00	\$1.00
x			Grade in Concentration	ppm		30		30	30	30	30	30
x			Penalty Increment	ppm		100		100	100	100	100	100
x			Threshold	ppm		300		300	300	300	300	300
		Capital Cost Estimate										
		SUSTAINING										
		Exploration Development		Cdn\$000's		8,040	1,320	1,360	2,680	2,680	-	-
		Mine Development		Cdn\$000's		-						
		Mine Equipment		Cdn\$000's		4,476		1,020	2,780	676		
		Closure and Salvage costs at Mine End		Cdn\$000's		1,750	-	250	250	250	250	250
		Subtotal		Cdn\$000's		14,266	-	2,630	5,710	3,606	250	250
		INITIAL										
		BK East Advanced Exploration		Cdn\$000's		10,000	10,000	-				
		Mining Equipment		Cdn\$000's		6,768	-	6,768				
		Mining Development		Cdn\$000's		2,825	-	2,825				
		Processing Plant		Cdn\$000's		18,850	-	18,850				
		Tailings		Cdn\$000's			-	-				
		Total Directs				38,443	10,000	28,443				
		Project Indirects		Cdn\$000's		5,725	-	5,725				
		Owners Cost + Insurance		Cdn\$000's		900	-	900				
		Contingency		Cdn\$000's			-	-				
		Total Indirects				6,625	-	6,625				
		Directs + Indirects				45,068	10,000	35,068				
		Contingency ==>	25%	(See above)		11,267	2,500	8,767				
		TOTAL INITIAL CAPITAL		Cdn\$000's		56,335	12,500	43,835				
		Cdn\$000's	Working Capital	3	(months of first yr OpCost)	4,860		4,860				(4,860)
		USD\$000's	TOTAL INITIAL CAPITAL			67,295	11,147	40,714	6,680	5,092	3,216	223
												(4,111)
		USD\$000's	TOTAL CAPITAL LOM			62,961						

LEAD CONCENTRATE CALCULATIONS									
	Unit	Year -2	Year -1	Year 1	Year 2	Year 3	Year 4	Year 5	TOTAL
MILL PRODUCTION									
Tonnes Ore Mined & Milled	000's t			91	91	91	91	44	409
Zinc Grade	%			4.900%	4.900%	4.900%	4.900%	4.900%	
Lead Grade	%			16.600%	16.600%	16.600%	16.600%	16.600%	
Gold Grade	g/t			0.220	0.220	0.220	0.220	0.220	
Silver Grade	g/t			1221.361	1221.361	1221.361	1221.361	1221.361	
Lead Recovery									
Recovered Lead	000's lbs			32,225	32,225	32,225	32,225	15,451	
Recovered Lead	000's t			14.617	14.617	14.617	14.617	7.008	
Zinc Recovery									
Recovered Zinc	000's lbs			680	680	680	680	326	3,047
Recovered Zinc	000's t			0.309	0.309	0.309	0.309	0.148	1.38
Silver Recovery									
Recovered Silver	000's oz			3,120.9	3,120.9	3,120.9	3,120.9	1,496.4	
Gold Recovery									
Recovered Gold	000's oz			0.3	0.3	0.3	0.3	0.2	1.45
CONCENTRATE GRADE									
Lead	%			72.00%	72.00%	72.00%	72.00%	72.00%	
Zinc	%			1.50%	1.50%	1.50%	1.50%	1.50%	
Silver	g/t			4782.929	4782.929	4782.929	4782.929	4782.929	
Gold	g/t			0.551	0.551	0.551	0.551	0.551	
Concentrate Moisture Content	%			8.0%	8.0%	8.0%	8.0%	8.0%	
DRY CONCENTRATE TONNAGE									
	dmt			20,302	20,302	20,302	20,302	9,734	90,941
RATIO OF CONCENTRATION									
				4.49	4.49	4.49	4.49	4.49	
WET CONCENTRATE TONNAGE									
	wmt			22,067	22,067	22,067	22,067	10,580	98,849

NET INVOICE VALUE (NIV) - Gross Value less Treatment Terms								
	Unit	Year -2	Year -1	Year 1	Year 2	Year 3	Year 4	Year 5
MILL PRODUCTION								
DRY CONCENTRATE TONNAGE	dmt			20,302	20,302	20,302	20,302	9,734
Head Grades								
Zinc	%			4.900%	4.900%	4.900%	4.900%	4.900%
Lead	%			16.600%	16.600%	16.600%	16.600%	16.600%
Gold	g/t			0.220	0.220	0.220	0.220	0.220
Silver	g/t			1221.361	1221.361	1221.361	1221.361	1221.361
Recoveries								
Zinc	%			6.90%	6.90%	6.90%	6.90%	6.90%
Lead	%			96.50%	96.50%	96.50%	96.50%	96.50%
Gold	%			50.00%	50.00%	50.00%	50.00%	50.00%
Silver	%			87.10%	87.10%	87.10%	87.10%	87.10%
CONCENTRATE GRADE								
Zinc	%			1.50%	1.50%	1.50%	1.50%	1.50%
Lead	%			72.00%	72.00%	72.00%	72.00%	72.00%
Gold	g/t			0.551	0.551	0.551	0.551	0.551
Silver	g/t			4782.929	4782.929	4782.929	4782.929	4782.929
CONTAINED METAL								
Zinc	lbs/dmt			33.069	33.069	33.069	33.069	33.069
Lead	lbs/dmt			1587.312	1587.312	1587.312	1587.312	1587.312
Gold	oz/dmt			0.018	0.018	0.018	0.018	0.018
Silver	oz/dmt			153.775	153.775	153.775	153.775	153.775
ACCOUNTABLE METAL								
Zinc	lbs/dmt			0.000	0.000	0.000	0.000	0.000
Lead	lbs/dmt			1507.946	1507.946	1507.946	1507.946	1507.946
Gold	oz/dmt			0.017	0.017	0.017	0.017	0.017
Silver	oz/dmt			138.397	138.397	138.397	138.397	138.397
METAL PRICES								
Zinc	US\$/lb			1.24	1.24	1.24	1.24	1.24
Lead	US\$/lb			0.81	0.81	0.81	0.81	0.81
Gold	US\$/oz			625.59	625.59	625.59	625.59	625.59
Silver	US\$/oz			11.69	11.69	11.69	11.69	11.69
GROSS CONCENTRATE VALUE								
Zinc	US\$/dmt			0.00	0.00	0.00	0.00	0.00
Lead	US\$/dmt			1,225.21	1,225.21	1,225.21	1,225.21	1,225.21
Gold	US\$/dmt			10.75	10.75	10.75	10.75	10.75
Silver	US\$/dmt			1,618.00	1,618.00	1,618.00	1,618.00	1,618.00
SUBTOTAL	US\$/dmt			2,853.96	2,853.96	2,853.96	2,853.96	2,853.96
TREATMENT TERMS								

NIV (Pb)

Smelting								
Zinc	US\$/dmt		0.00	0.00	0.00	0.00	0.00	0.00
Lead	US\$/dmt		60.10	60.10	60.10	60.10	60.10	60.10
Gold	US\$/dmt		0.53	0.53	0.53	0.53	0.53	0.53
Silver	US\$/dmt		79.37	79.37	79.37	79.37	79.37	79.37
Total Smelting	US\$/dmt		140.00	140.00	140.00	140.00	140.00	140.00
Refining								
Zinc	US\$/dmt		0.00	0.00	0.00	0.00	0.00	0.00
Gold	US\$/dmt		0.10	0.10	0.10	0.10	0.10	0.10
Silver	US\$/dmt		48.44	48.44	48.44	48.44	48.44	48.44
Price Escalation (Lead)	US\$/dmt		102.35	102.35	102.35	102.35	102.35	102.35
Subtotal Zinc	US\$/dmt		0.00	0.00	0.00	0.00	0.00	0.00
Subtotal Lead	US\$/dmt		162.45	162.45	162.45	162.45	162.45	162.45
Subtotal Gold	US\$/dmt		0.63	0.63	0.63	0.63	0.63	0.63
Subtotal Silver	US\$/dmt		127.81	127.81	127.81	127.81	127.81	127.81
Total Treatment Terms	US\$/dmt		290.89	290.89	290.89	290.89	290.89	290.89
Smelting and Refining / Tonne			64.72					
METAL PENALTIES								
Arsenic	US\$/dmt		0.00	0.00	0.00	0.00	0.00	0.00
Antimony	US\$/dmt		7.35	7.35	7.35	7.35	7.35	7.35
Mercury	US\$/dmt		0.00	0.00	0.00	0.00	0.00	0.00
Selenium	US\$/dmt		0	0	0	0	0	0
Zinc	US\$/dmt		0.00	0.00	0.00	0.00	0.00	0.00
Subtotal Zinc	US\$/dmt		0.00	0.00	0.00	0.00	0.00	0.00
Subtotal Gold	US\$/dmt		0.00	0.00	0.00	0.00	0.00	0.00
Subtotal Silver	US\$/dmt		0.00	0.00	0.00	0.00	0.00	0.00
NET INVOICE UNIT VALUE	US\$/dmt		2,555.72	2,555.72	2,555.72	2,555.72	2,555.72	2,555.72
NET INVOICE VALUE	000's US\$		51,885.77	51,885.77	51,885.77	51,885.77	51,885.77	24,877.31
Net Invoice Unit Value by METAL CONTRIBUTION								
Zinc	US\$/dmt		0.00	0.00	0.00	0.00	0.00	0.00
Lead	US\$/dmt		1062.75	1062.75	1062.75	1062.75	1062.75	1062.75
Gold	US\$/dmt		10.12	10.12	10.12	10.12	10.12	10.12
Silver	US\$/dmt		1490.19	1490.19	1490.19	1490.19	1490.19	1490.19
SUBTOTAL	US\$/dmt		2,563.07	2,563.07	2,563.07	2,563.07	2,563.07	2,563.07
% Gross Contribution	Zinc		0.0%	0.0%	0.0%	0.0%	0.0%	0.0%
	Lead		42.9%	42.9%	42.9%	42.9%	42.9%	42.9%
	Gold		0.4%	0.4%	0.4%	0.4%	0.4%	0.4%
	Silver		56.7%	56.7%	56.7%	56.7%	56.7%	56.7%
	Total		100.0%	100.0%	100.0%	100.0%	100.0%	100.0%

NET SMELTER RETURN (NSR) - Net Invoice Value less Transportation Costs, Losses, Insurance,								
	Unit	Year -2	Year -1	Year 1	Year 2	Year 3	Year 4	Year 5
MILL PRODUCTION								
DRY CONCENTRATE TONNAGE	dmt			20,302	20,302	20,302	20,302	9,734
WET CONCENTRATE TONNAGE	wmt			22,067	22,067	22,067	22,067	10,580
NIV VALUE	US\$/dmt			2,555.72	2,555.72	2,555.72	2,555.72	2,555.72
TRANSPORTATION								
Mine to Port	US\$/dmt			176.28	176.28	176.28	176.28	176.28
Storage and Vessel Loading	US\$/dmt			0.00	0.00	0.00	0.00	0.00
Land + Ocean Freight	US\$/dmt			0.00	0.00	0.00	0.00	0.00
Representation	US\$/dmt			0.54	0.54	0.54	0.54	0.54
Insurance	US\$/dmt			0.00	0.00	0.00	0.00	0.00
Losses	US\$/dmt			0.01	0.01	0.01	0.01	0.01
SUBTOTAL	US\$/dmt			176.83	176.83	176.83	176.83	176.83
Transportation Cost per tonne				39.34				
NSR UNIT VALUE	US\$/dmt			2,378.88	2,378.88	2,378.88	2,378.88	2,378.88
NSR VALUE	000's US\$			48,296	48,296	48,296	48,296	23,156
Transport cost by METAL CONTRIBUTION								
Zinc	US\$/dmt			0.00	0.00	0.00	0.00	0.00
Lead	US\$/dmt			75.91	75.91	75.91	75.91	75.91
Gold	US\$/dmt			0.67	0.67	0.67	0.67	0.67
Silver	US\$/dmt			100.25	100.25	100.25	100.25	100.25
Net Smelter Return Unit Value by METAL CONTRIBUTION								
Zinc	US\$/dmt			0.00	0.00	0.00	0.00	0.00
Lead	US\$/dmt			986.84	986.84	986.84	986.84	986.84
Gold	US\$/dmt			9.46	9.46	9.46	9.46	9.46
Silver	US\$/dmt			1,389.94	1,389.94	1,389.94	1,389.94	1,389.94
Total	US\$/dmt			2,386.23	2,386.23	2,386.23	2,386.23	2,386.23
% Contribution NSR by METAL								
Zinc	%			0.0%	0.0%	0.0%	0.0%	0.0%
Lead	%			41.4%	41.4%	41.4%	41.4%	41.4%
Gold	%			0.4%	0.4%	0.4%	0.4%	0.4%
Silver	%			58.2%	58.2%	58.2%	58.2%	58.2%
Total	%			100.0%	100.0%	100.0%	100.0%	100.0%

Conc Tonnes & Grade (Zn)

ZINC CONCENTRATE CALCULATIONS									
	Unit	Year -2	Year -1	Year 1	Year 2	Year 3	Year 4	Year 5	TOTAL
MILL PRODUCTION									
Tonnes Ore Mined & Milled	000's t			91	91	91	91	44	409
Zinc Grade	%			4.900%	4.900%	4.900%	4.900%	4.900%	
Lead Grade	%			16.600%	16.600%	16.600%	16.600%	16.600%	
Gold Grade	g/t			0.220	0.220	0.220	0.220	0.220	
Silver Grade	g/t			1221.361	1221.361	1221.361	1221.361	1221.361	
Lead Recovery	%			1.30%	1.30%	1.30%	1.30%	1.30%	
Recovered Lead	000's lbs			434	434	434	434	208	
Recovered Lead	000's t			0.197	0.197	0.197	0.197	0.094	
Zinc Recovery	%			90.20%	90.20%	90.20%	90.20%	90.20%	
Recovered Zinc	000's lbs			8,891	8,891	8,891	8,891	4,263	39,828
Recovered Zinc	000's t			4.033	4.033	4.033	4.033	1.934	18.066
Gold Recovery	%			17.00%	17.00%	17.00%	17.00%	17.00%	
Recovered Gold	000's oz			0.1	0.1	0.1	0.1	0.1	
Silver Recovery	%			8.00%	8.00%	8.00%	8.00%	8.00%	
Recovered Silver	000's oz			286.7	286.7	286.7	286.7	137.4	
CONCENTRATE GRADE									
Zinc	%			52.00%	52.00%	52.00%	52.00%	52.00%	
Lead	%			2.60%	2.60%	2.60%	2.60%	2.60%	
Gold	g/t			0.551	0.551	0.551	0.551	0.551	
Silver	g/t			1158.529	1158.529	1158.529	1158.529	1158.529	
Concentrate Moisture Content	%			8.0%	8.0%	8.0%	8.0%	8.0%	
DRY CONCENTRATE TONNAGE	dmt	0	0	7,756	7,756	7,756	7,756	3,719	34,742
RATIO OF CONCENTRATION		0.00	0.00	11.77	11.77	11.77	11.77	11.77	
WET CONCENTRATE TONNAGE	wmt	0	0	8,430	8,430	8,430	8,430	4,042	37,763

NET INVOICE VALUE (NIV) - Gross Value less Treatment Terms								
	Unit	Year -2	Year -1	Year 1	Year 2	Year 3	Year 4	Year 5
MILL PRODUCTION								
DRY CONCENTRATE TONNAGE	dmt	0	0	7,756	7,756	7,756	7,756	3,719
Head Grades								
Zinc	%			4.900%	4.900%	4.900%	4.900%	4.900%
Lead	%			16.600%	16.600%	16.600%	16.600%	16.600%
Gold	g/t			0.220	0.220	0.220	0.220	0.220
Silver	g/t			1221.361	1221.361	1221.361	1221.361	1221.361
Recoveries								
Zinc	%			90.20%	90.20%	90.20%	90.20%	90.20%
Lead	%			1.30%	1.30%	1.30%	1.30%	1.30%
Gold	%			17.00%	17.00%	17.00%	17.00%	17.00%
Silver	%			8.00%	8.00%	8.00%	8.00%	8.00%
CONCENTRATE GRADE								
Zinc	%			52.00%	52.00%	52.00%	52.00%	52.00%
Lead	%			2.60%	2.60%	2.60%	2.60%	2.60%
Gold	g/t			0.551	0.551	0.551	0.551	0.551
Silver	g/t			1158.529	1158.529	1158.529	1158.529	1158.529
CONTAINED METAL								
Zinc	lbs/dmt			1146.392	1146.392	1146.392	1146.392	1146.392
Lead	lbs/dmt			57.320	57.320	57.320	57.320	57.320
Gold	oz/dmt			0.018	0.018	0.018	0.018	0.018
Silver	oz/dmt			37.248	37.248	37.248	37.248	37.248
ACCOUNTABLE METAL								
Zinc	lbs/dmt			974.433	974.433	974.433	974.433	974.433
Lead	lbs/dmt			0.000	0.000	0.000	0.000	0.000
Gold	oz/dmt			0.017	0.017	0.017	0.017	0.017
Silver	oz/dmt			24.211	24.211	24.211	24.211	24.211
METAL PRICES								
Zinc	US\$/lb			1.24	1.24	1.24	1.24	1.24
Lead	US\$/lb			0.81	0.81	0.81	0.81	0.81
Gold	US\$/oz			625.59	625.59	625.59	625.59	625.59
Silver	US\$/oz			11.69	11.69	11.69	11.69	11.69
GROSS CONCENTRATE VALUE								
Zinc	US\$/dmt			1,207.32	1,207.32	1,207.32	1,207.32	1,207.32
Lead	US\$/dmt			0.00	0.00	0.00	0.00	0.00
Gold	US\$/dmt			10.75	10.75	10.75	10.75	10.75
Silver	US\$/dmt			283.05	283.05	283.05	283.05	283.05
SUBTOTAL	US\$/dmt			1,501.13	1,501.13	1,501.13	1,501.13	1,501.13
TREATMENT TERMS								

NIV (Zn)

Smelting								
Zinc	US\$/dmt		180.96	180.96	180.96	180.96	180.96	180.96
Lead	US\$/dmt		0.00	0.00	0.00	0.00	0.00	0.00
Gold	US\$/dmt		1.61	1.61	1.61	1.61	1.61	1.61
Silver	US\$/dmt		42.43	42.43	42.43	42.43	42.43	42.43
Total Smelting	US\$/dmt		225.00	225.00	225.00	225.00	225.00	225.00
Refining								
Zinc	US\$/dmt		0.00	0.00	0.00	0.00	0.00	0.00
Lead	US\$/dmt		0.00	0.00	0.00	0.00	0.00	0.00
Gold	US\$/dmt		0.10	0.10	0.10	0.10	0.10	0.10
Silver	US\$/dmt		8.47	8.47	8.47	8.47	8.47	8.47
Price Escalation (Zinc)	US\$/dmt		94.17	94.17	94.17	94.17	94.17	94.17
Subtotal Zinc	US\$/dmt		275.13	275.13	275.13	275.13	275.13	275.13
Subtotal Lead	US\$/dmt		0.00	0.00	0.00	0.00	0.00	0.00
Subtotal Gold	US\$/dmt		1.71	1.71	1.71	1.71	1.71	1.71
Subtotal Silver	US\$/dmt		50.90	50.90	50.90	50.90	50.90	50.90
Total Treatment Terms	US\$/dmt		327.75	327.75	327.75	327.75	327.75	327.75
Treatment Cost per tonne			27.86					
METAL PENALTIES								
Antimony	US\$/dmt		\$ -	\$ -	\$ -	\$ -	\$ -	\$ -
Arsenic	US\$/dmt		\$ -	\$ -	\$ -	\$ -	\$ -	\$ -
Cadmium	US\$/dmt		\$ 3.60	\$ 3.60	\$ 3.60	\$ 3.60	\$ 3.60	\$ 3.60
Fluorine	US\$/dmt		\$ -	\$ -	\$ -	\$ -	\$ -	\$ -
Iron	US\$/dmt		\$ -	\$ -	\$ -	\$ -	\$ -	\$ -
Mercury	US\$/dmt		\$ -	\$ -	\$ -	\$ -	\$ -	\$ -
Mercury	US\$/dmt		\$ -	\$ -	\$ -	\$ -	\$ -	\$ -
Selenium	US\$/dmt		\$ -	\$ -	\$ -	\$ -	\$ -	\$ -
NET INVOICE UNIT VALUE	US\$/dmt		1,169.78	1,169.78	1,169.78	1,169.78	1,169.78	1,169.78
NET INVOICE VALUE	000's US\$		9,072.69	9,072.69	9,072.69	9,072.69	9,072.69	4,350.02
Net Invoice Unit Value by METAL CONTRIBUTION								
Zinc	US\$/dmt		928.59	928.59	928.59	928.59	928.59	928.59
Lead	US\$/dmt		0.00	0.00	0.00	0.00	0.00	0.00
Gold	US\$/dmt		9.04	9.04	9.04	9.04	9.04	9.04
Silver	US\$/dmt		232.15	232.15	232.15	232.15	232.15	232.15
SUBTOTAL	US\$/dmt		1169.78	1169.78	1169.78	1169.78	1169.78	1169.78
% Gross Contribution								
	Zinc		80.4%	80.4%	80.4%	80.4%	80.4%	80.4%
	Lead		0.0%	0.0%	0.0%	0.0%	0.0%	0.0%
	Gold		0.7%	0.7%	0.7%	0.7%	0.7%	0.7%
	Silver		18.9%	18.9%	18.9%	18.9%	18.9%	18.9%
	Total		100.0%	100.0%	100.0%	100.0%	100.0%	100.0%

NET SMELTER RETURN (NSR) - Net Invoice Value less Transportation Costs, Losses, Insurance, and Representati								
	Unit	Year -2	Year -1	Year 1	Year 2	Year 3	Year 4	Year 5
MILL PRODUCTION								
DRY CONCENTRATE TONNAGE	dmt			7,756	7,756	7,756	7,756	3,719
WET CONCENTRATE TONNAGE	wmt			8,430	8,430	8,430	8,430	4,042
NIV VALUE	US\$/dmt			1,169.78	1,169.78	1,169.78	1,169.78	1,169.78
TRANSPORTATION (adjusted for moisture and currency)								
Mine to Port	US\$/dmt			176.28	176.28	176.28	176.28	176.28
Storage and Vessel Loading	US\$/dmt			0.00	0.00	0.00	0.00	0.00
Land + Ocean Freight	US\$/dmt			0.00	0.00	0.00	0.00	0.00
Representation	US\$/dmt			0.54	0.54	0.54	0.54	0.54
Insurance	US\$/dmt			0.00	0.00	0.00	0.00	0.00
Losses	US\$/dmt			0.01	0.01	0.01	0.01	0.01
SUBTOTAL	US\$/dmt			176.83	176.83	176.83	176.83	176.83
Transport Cost per tonne of ore				15.03				
NSR UNIT VALUE	US\$/dmt			992.95	992.95	992.95	992.95	992.95
NSR VALUE	000's US\$			7,701	7,701	7,701	7,701	3,692
Transport cost by METAL CONTRIBUTION								
Zinc	US\$/dmt			142.22	142.22	142.22	142.22	142.22
Lead	US\$/dmt			0.00	0.00	0.00	0.00	0.00
Gold	US\$/dmt			1.27	1.27	1.27	1.27	1.27
Silver	US\$/dmt			33.34	33.34	33.34	33.34	33.34
Net Smelter Return Unit Value by METAL CONTRIBUTION								
Zinc	US\$/dmt			786.37	786.37	786.37	786.37	786.37
Lead	US\$/dmt			0.00	0.00	0.00	0.00	0.00
Gold	US\$/dmt			7.77	7.77	7.77	7.77	7.77
Silver	US\$/dmt			198.81	198.81	198.81	198.81	198.81
Total	US\$/dmt			992.95	992.95	992.95	992.95	992.95
% Contribution NSR by METAL								
Zinc	%			79.2%	79.2%	79.2%	79.2%	79.2%
Lead	%			0.0%	0.0%	0.0%	0.0%	0.0%
Gold	%			0.8%	0.8%	0.8%	0.8%	0.8%
Silver	%			20.0%	20.0%	20.0%	20.0%	20.0%
Total	%			100.0%	100.0%	100.0%	100.0%	100.0%

Silver Costs

		Year 1	Year 2	Year 3	Year 4	Year 5
COSTS						
Opcosts	USD 000's	\$17,336.94	\$19,008.38	\$15,414.86	\$14,745.96	\$7,173.14
Royalty	USD 000's	\$ -	\$ 247.33	\$ 747.68	\$ 747.68	\$ 358.48
Smelting , Refining, and TRPRT	USD 000's	\$13,586	\$13,586	\$13,586	\$13,586	\$6,514
Gross Metal Value from Zinc	USD 000's	\$6,099	\$6,099	\$6,099	\$6,099	\$2,924
Gross Metal Value from Lead	USD 000's	\$20,035	\$20,035	\$20,035	\$20,035	\$9,606
Silver Cost SW+99	USD 000's	\$ 4,789.54	\$ 6,708.32	\$ 3,615.14	\$ 2,946.24	\$ 1,515.62
Silver Cost East Zone	USD 000's	\$ -	\$ -	\$ (5,222.75)	\$ (5,624.09)	\$ (9,605.70)
Total Cost For Silver	USD 000's	\$ 4,789.54	\$ 6,708.32	\$ (1,607.61)	\$ (2,677.85)	\$ (8,090.09)
ACCOUNTABLE SILVER						
Total Accountable Silver SW+99	Oz	2,997,495	2,997,495	2,997,495	2,997,495	1,437,188
Total Accountable Silver East Zone	Oz	0	0	289,520	289,520	506,087
Total Accountable Silver Bellekeno	Oz	2,997,495	2,997,495	3,287,015	3,287,015	1,943,275
Unit Cost per Accountable Silver	USD/Oz	\$ 1.60	\$ 2.24	\$ (0.49)	\$ (0.81)	\$ (4.16)

Pre-Tax CashFlow

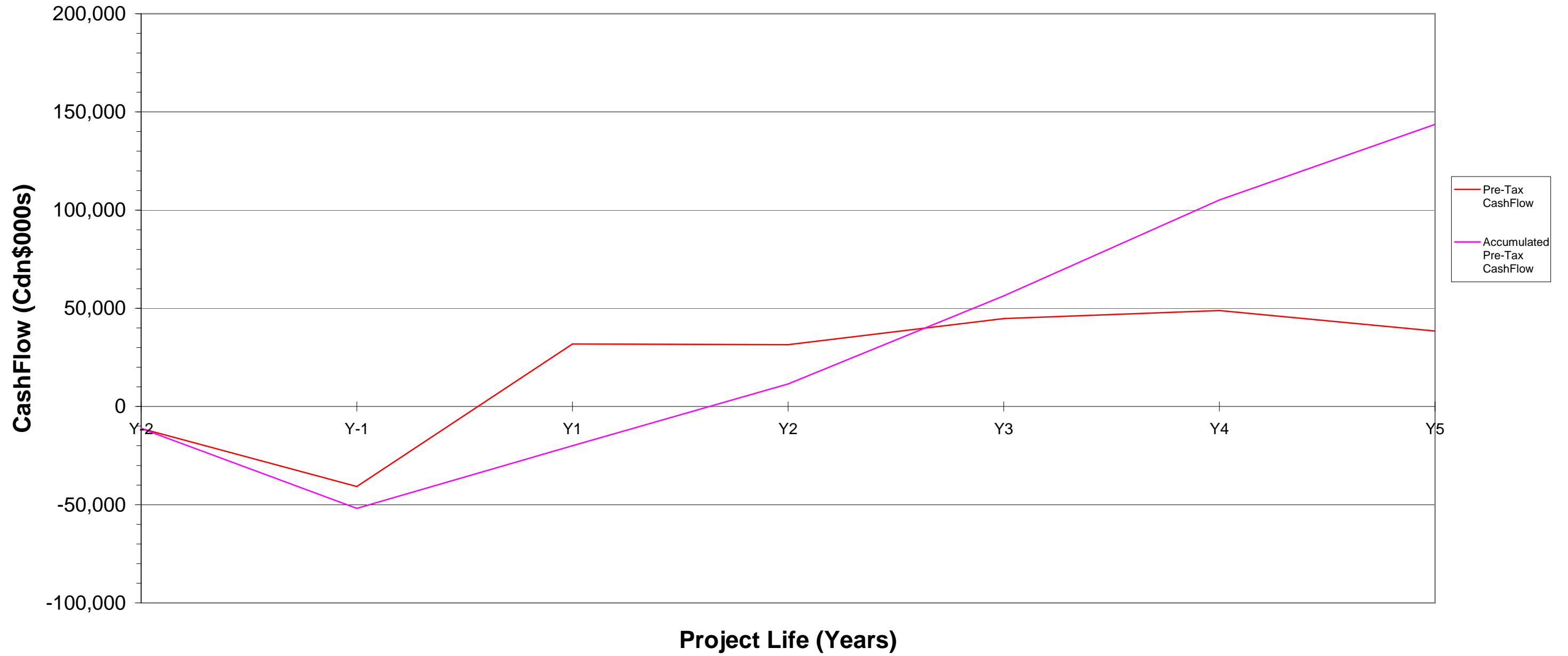

NPV Sensitivity Analysis

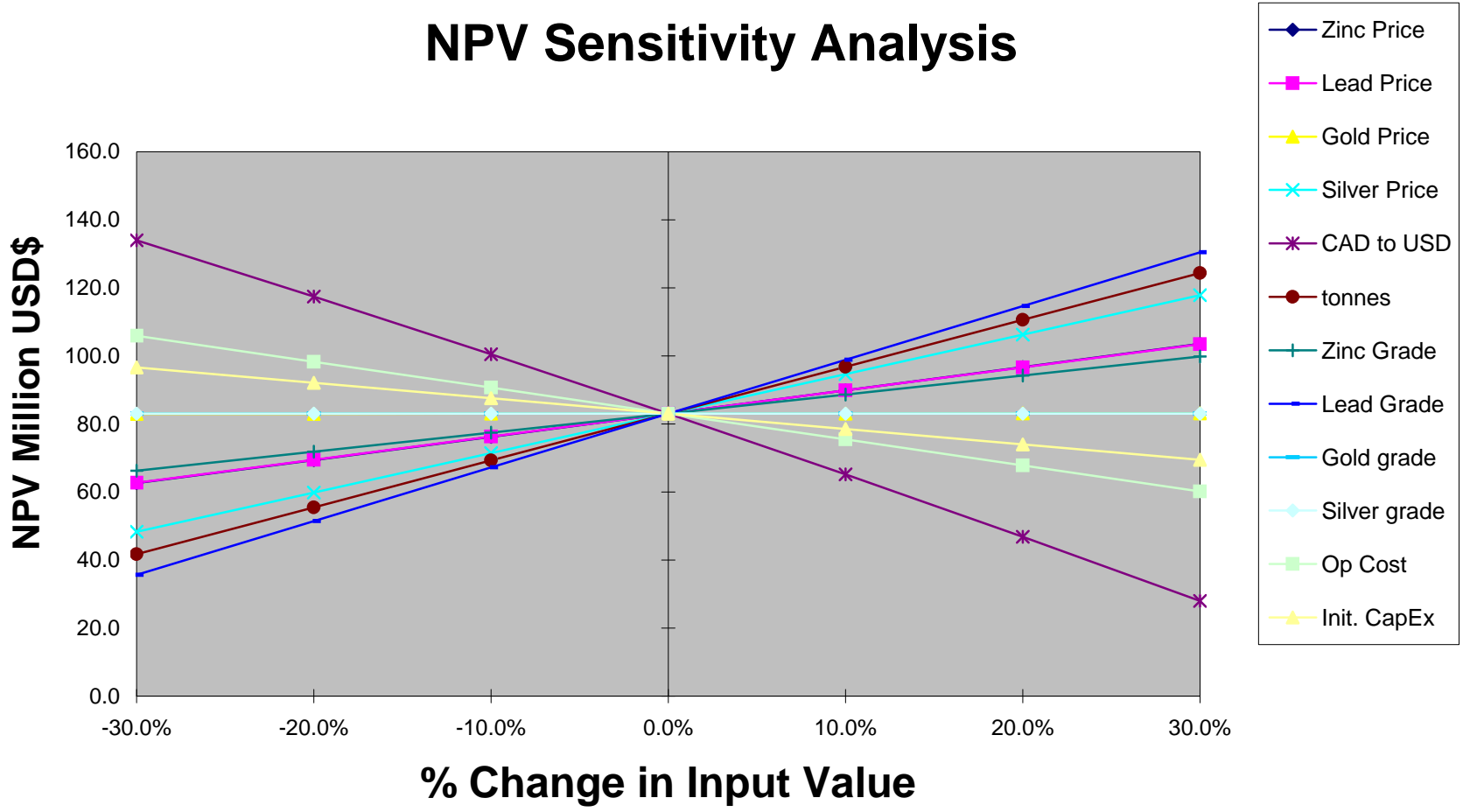

NPV Sensitivity Analysis

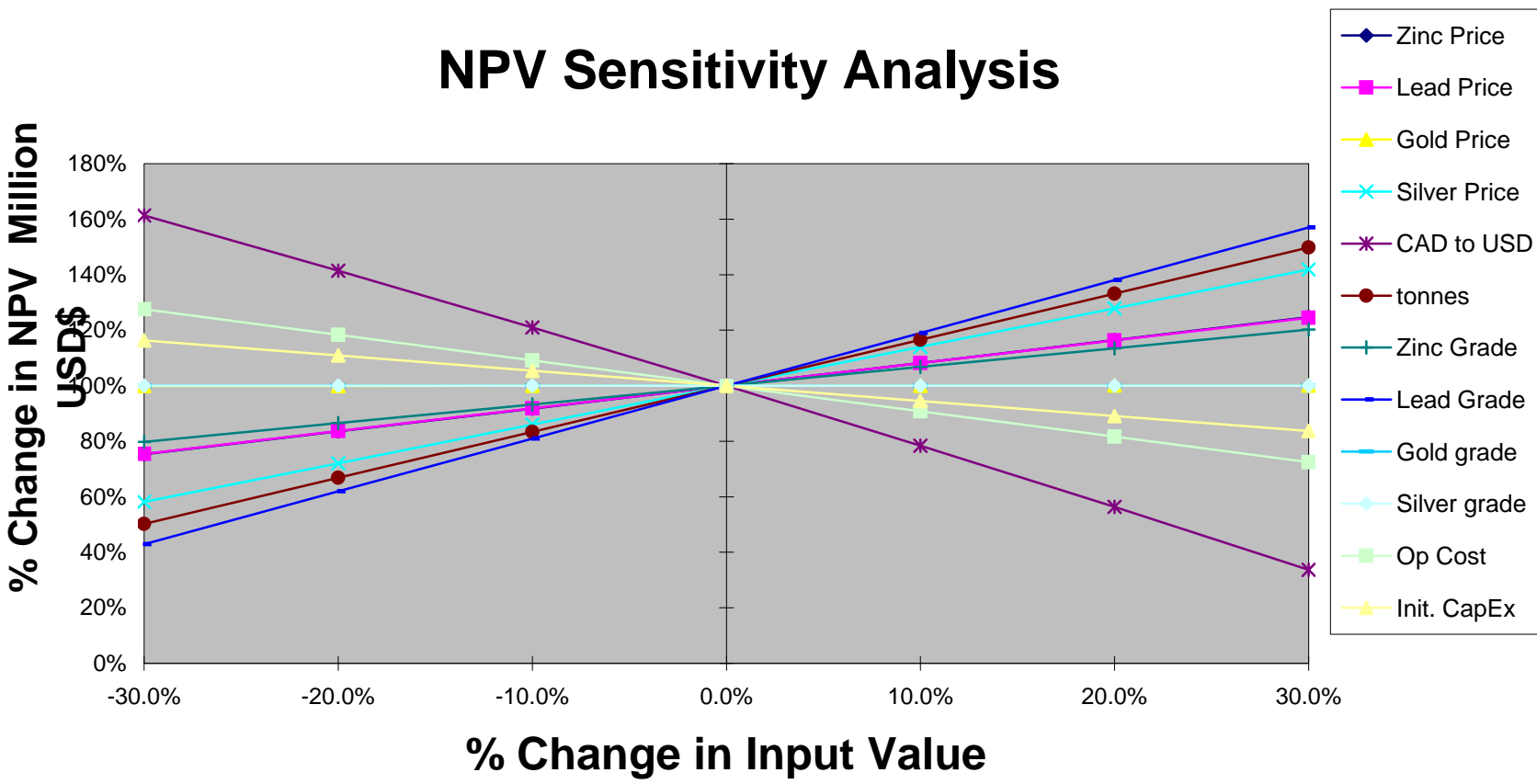

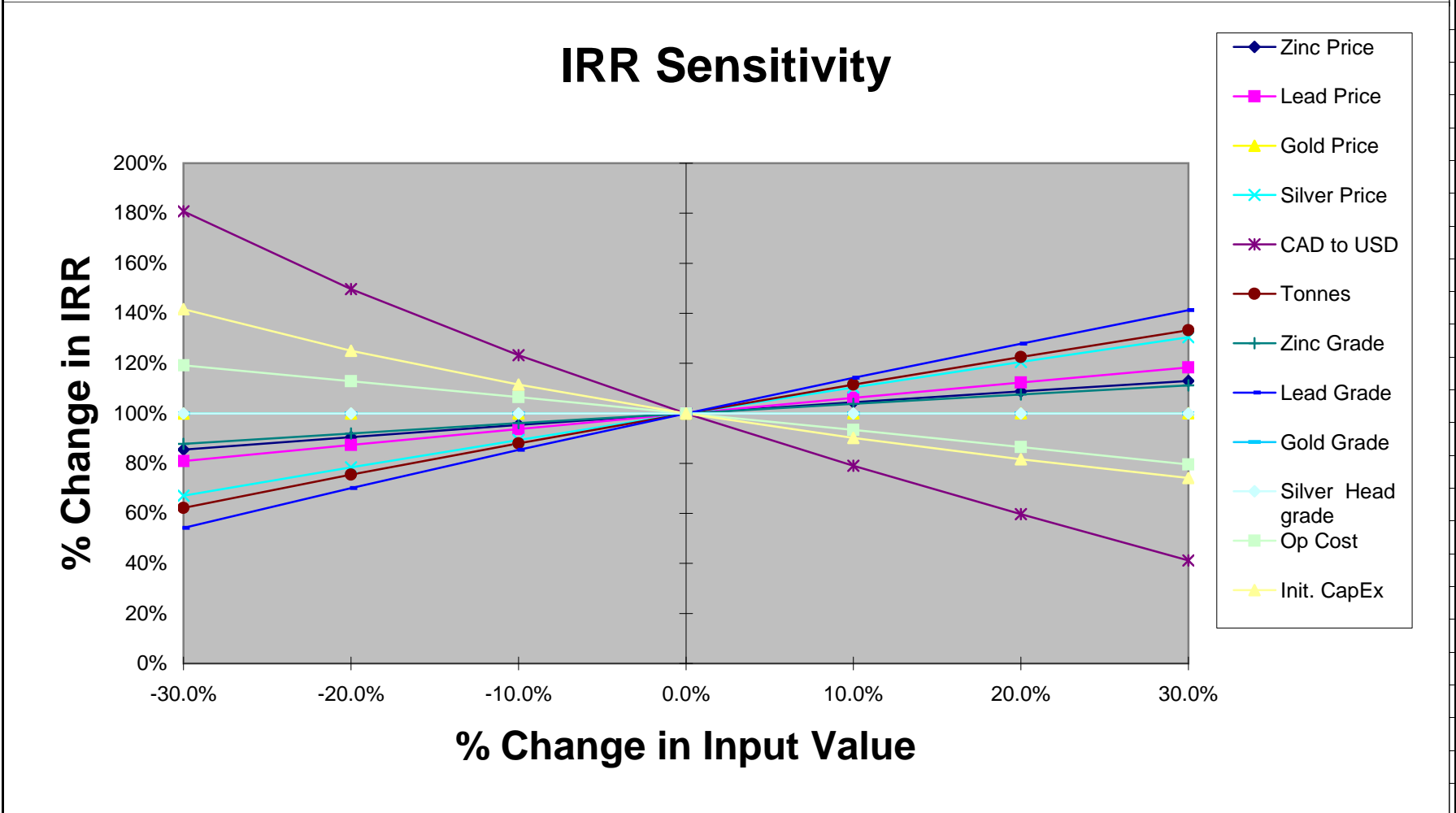
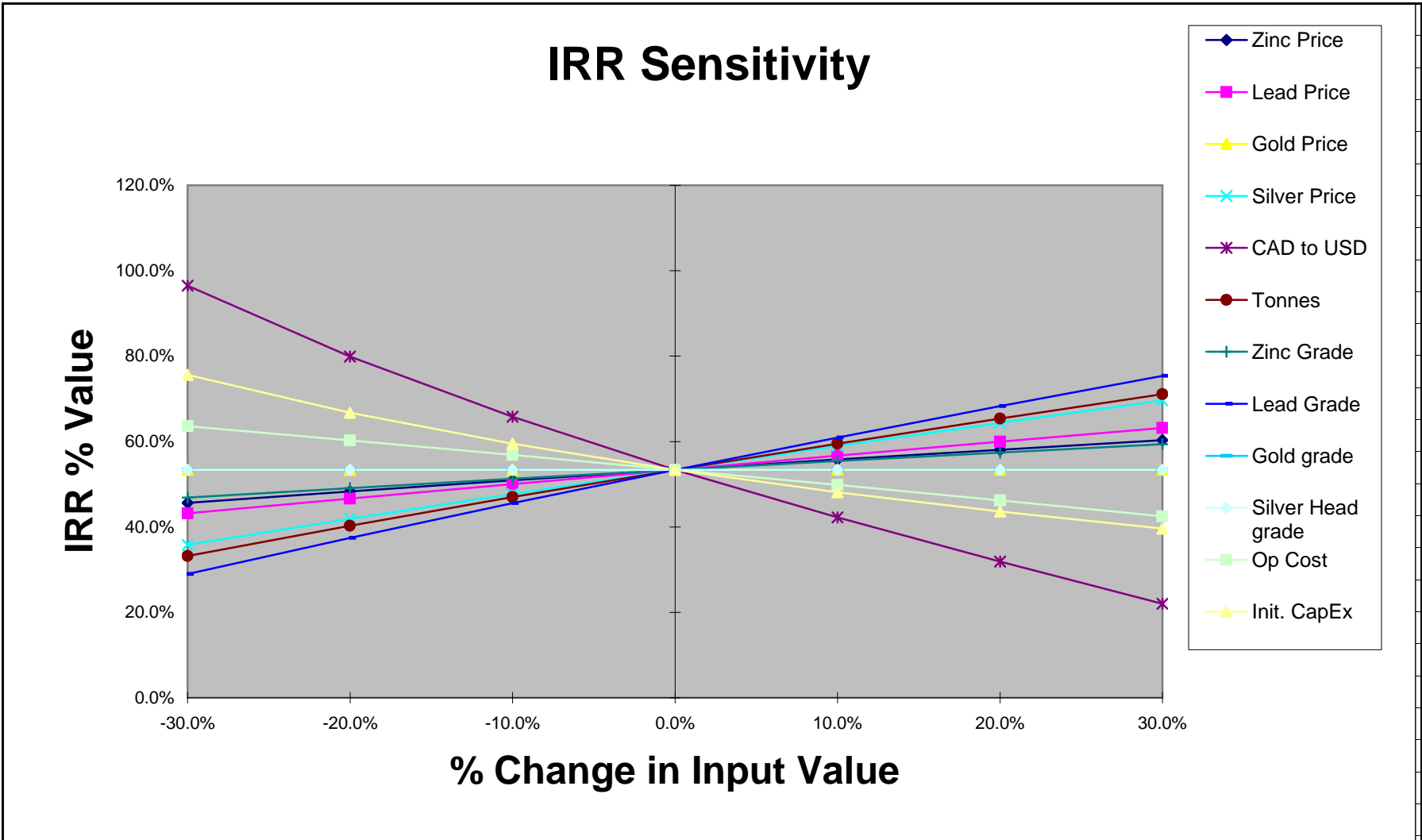

PRE-TAX AND PRE-FINANCE ECONOMIC MODEL EAST ZONE											
Client		Alexco									WARDROP
Project		Bellekeno									
Version		006		3 YEAR AVERAGE PRICES							
Creation Date		7-Jul-08									
		Source	Units	Y-2 2008	Y-1 2009	Y1 2010	Y2 2011	Y3 2012	Y4 2013	Y5 2014	TOTAL
Metal Prices											
	Zinc	LME	US\$/lb			1.24	1.24	1.24	1.24	1.24	
	Gold	LME	US\$/oz			625.59	625.59	625.59	625.59	625.59	
	Lead	LME	US\$/lb			0.81	0.81	0.81	0.81	0.81	
	Silver	LME	US\$/oz			11.69	11.69	11.69	11.69	11.69	
Mining Production											
	Tonnes Ore Mined & Milled		000's tonnes			0	0	55	55	96	205
	Lead Grade		%			1.80%	1.80%	1.80%	1.80%	1.80%	
	Zinc Grade		%			19.00%	19.00%	19.00%	19.00%	19.00%	
	Gold Grade		g/t			0.551	0.551	0.551	0.551	0.551	
	Silver Grade		g/t			231.49	231.49	231.49	231.49	231.49	
Lead Concentrate											
	Tonnage		dmt			0	0	1,314	1,314	2,297	4,925
Concentrate Grade											
	Lead		%			60.00%	60.00%	60.00%	60.00%	60.00%	
	Silver		g/t			7020.621	7020.621	7020.621	7020.621	7020.621	
Metallurgical Recovery											
	Lead		%			80.00%	80.00%	80.00%	80.00%	80.00%	
	Silver		%			72.20%	72.20%	72.20%	72.20%	72.20%	
Recovered Metal											
	Lead		million lb			0.0	0.0	1.7	1.7	3.0	
	Silver		oz			0	0	296,593	296,593	518,451	1,111,637
Accountable Metal											
	Lead		million lb			0.0	0.0	1.7	1.7	2.9	
	Silver		oz			0.0	0.0	266,934.0	266,934.0	466,605.5	1,000,473
Gross Revenue by Metal											
	Lead		000's US\$			\$0	\$0	\$1,342	\$1,342	\$2,345	
	Silver		000's US\$			\$0	\$0	\$3,121	\$3,121	\$5,455	
	Total Lead Gross Revenue	W	000's US\$	\$0	\$0	\$0	\$0	\$4,731	\$4,731	\$8,269	17,731
Zinc Concentrate											
	Tonnage		dmt			0	0	18,157	18,157	31,739	68,053
Concentrate Grade											
	Zinc		%			55.00%	55.00%	55.00%	55.00%	55.00%	
	Silver		g/t			59.525	59.525	59.525	59.525	59.525	
Metallurgical Recovery											
	Zinc		%			96.00%	96.00%	96.00%	96.00%	96.00%	
	Silver		%			8.50%	8.50%	8.50%	8.50%	8.50%	
Recovered Metal											
	Zinc		million lb			0.0	0.0	22.0	22.0	38.5	82.5
	Silver		oz			0	0	34,748	34,748	60,741	130,238
Accountable Metal											
	Zinc		million lb			0.0	0.0	18.7	18.7	32.7	70.1
	Silver		oz			0	0	22,586	22,586	39,482	84,654

	Source	Units	Y-2	Y-1	Y1	Y2	Y3	Y4	Y5	TOTAL
Gross Revenue by Metal										
Zinc		000's US\$			\$0	\$0	\$23,186	\$23,186	\$40,530	86,902
Silver		000's US\$			\$0	\$0	\$264	\$264	\$462	990
Total Zinc Gross Revenue	W	000's US\$	\$0	\$0	\$0	\$0	\$23,567	\$23,567	\$41,196	88,331
Zinc Concentrate										
Total Zinc		000's US\$			\$0	\$0	\$23,186	\$23,186	\$40,530	86,902
Total Lead		000's US\$			\$0	\$0	\$1,342	\$1,342	\$2,345	5,028
Total Silver		000's US\$			\$0	\$0	\$3,385	\$3,385	\$5,917	12,686
Total Gross Revenue		000's US\$	\$0	\$0	\$0	\$0	\$28,298	\$28,298	\$49,466	106,062
Lead Concentrate										
Smelting & Refining & Price Participation		000's US\$			\$0	\$0	\$392	\$392	\$685	
Metal Penalties		000's US\$			\$0	\$0	\$10	\$10	\$17	
Transportation		000's US\$			\$0	\$0	\$232	\$232	\$406	
Total		000's US\$			\$0	\$0	\$634	\$634	\$1,108	2,376
Lead Net Smelter Return	W	000's US\$			\$0	\$0	\$4,097	\$4,097	\$7,161	15,355
Zinc Concentrate										
Smelting & Refining & Price Participation		000's US\$			\$0	\$0	\$5,903	\$5,903	\$10,318	
Metal Penalties		000's US\$			\$0	\$0	\$65	\$65	\$114	
Transportation		000's US\$			\$0	\$0	\$3,211	\$3,211	\$5,612	
Total		000's US\$	\$0	\$0	\$0	\$0	\$9,179	\$9,179	\$16,045	34,403
Zinc Net Smelter Return	W	000's US\$	\$0	\$0	\$0	\$0	\$14,388	\$14,388	\$25,151	53,928
Lead and Zinc Concentrate										
Smelting & Refining & Price Participation		000's US\$			\$0	\$0	\$6,295	\$6,295	\$11,004	23,593
Metal Penalties		000's US\$			\$0	\$0	\$75	\$75	\$131	281
Transportation		000's US\$			\$0	\$0	\$3,443	\$3,443	\$6,019	12,905
Total		000's US\$	\$0	\$0	\$0	\$0	\$9,813	\$9,813	\$17,153	36,779
Net Revenue by Metal										
Total Zinc		000's US\$			\$0	\$0	\$14,134	\$14,134	\$24,707	52,975
Total Lead		000's US\$			\$0	\$0	\$1,111	\$1,111	\$1,943	4,166
Total Silver		000's US\$			\$0	\$0	\$2,927	\$2,927	\$5,117	10,971
Net Revenue	W	000's US\$	\$0	\$0	\$0	\$0	\$18,173	\$18,173	\$31,766	68,112
Royalty Payments										
	W	000's US\$	\$0	\$0	\$0	\$0	\$273	\$273	\$476	1,022
Operating Cost										
Underground Mining		000's CAD\$			\$0	\$0	\$6,594	\$6,144	\$10,888	23,626
Milling		000's CAD\$			\$0	\$0	\$2,514	\$2,514	\$4,394	9,421
General & Administration		000's CAD\$			\$0	\$0	\$1,264	\$1,264	\$2,313	4,840
SubTotal Operating Cost	W	000's US\$	\$0	\$0	\$0	\$0	\$9,249	\$8,848	\$15,691	33,788
Capital Costs										
All Capital Costs are taken into account in SW+99 Financial Model										
Total Capital Cost	W	000's US\$	0	0	0	0	0	0	0	0
Summary										
Net Revenue		000's US\$	0	0	0	0	18,173	18,173	31,766	68,112
Royalty Payments		000's US\$	0	0	0	0	273	273	476	1,022

	Source	Units	Y-2	Y-1	Y1	Y2	Y3	Y4	Y5	TOTAL
Operating Cost		000's US\$	0	0	0	0	9,249	8,848	15,691	33,788
Capital Costs		000's US\$	0	0	0	0	0	0	0	0
Pre-Tax Cash Flow										
Cash Flow		000's US\$	0	0	0	0	8,651	9,053	15,599	33,303
Accumulated Cash Flow		000's US\$	0	0	0	0	8,651	17,704	33,303	
Discounted Cash Flow		000's US\$	0	0	0	0	5,888	5,705	9,102	20,694
Accumulated Discounted Cash Flow		000's US\$	0	0	0	0	5,888	11,593	20,694	
Discount Rate		%	8.0%							
Total Operating Cost		Cdn\$/t	189.43							
Mine Life		Yrs	3.0							
Legend										
W - Wardrop										
LME - London Metal Exchange										
AL- Alexco Resources										

				Units	Source	Input	Year -2	Year -1	Year 1	Year 2	Year 3	Year 4	Year 5
TREATMENT TERMS													
Lead Concentrate													
x		Smelting		US\$/dmt		\$140.00			140.00	140.00	140.00	140.00	140.00
		Refining											
x		Zinc		US\$/acc lb		\$0.000			\$0.000	\$0.000	\$0.000	\$0.000	\$0.000
x		Lead				\$0.000			\$0.000	\$0.000	\$0.000	\$0.000	\$0.000
x		Gold		US\$/acc oz		\$6.000			\$6.000	\$6.000	\$6.000	\$6.000	\$6.000
x		Silver		US\$/acc oz		\$0.350			\$0.350	\$0.350	\$0.350	\$0.350	\$0.350
		Price Escalation				15.0%			15.0%	15.0%	15.0%	15.0%	15.0%
x		Base Price \$US/lb				\$0.36			0.36	0.36	0.36	0.36	0.36
Zinc Concentrate													
x		Smelting		US\$/dmt		\$225.00			225.00	225.00	225.00	225.00	225.00
		Refining											
x		Zinc		US\$/acc lb		\$0.000			\$0.000	\$0.000	\$0.000	\$0.000	\$0.000
x		Gold		US\$/acc oz		\$5.000			\$5.000	\$5.000	\$5.000	\$5.000	\$5.000
x		Silver		US\$/acc oz		\$0.400			\$0.400	\$0.400	\$0.400	\$0.400	\$0.400
x		Price Escalation (above base)				16.0%			16.0%	16.0%	16.0%	16.0%	16.0%
x		Price Escalation (below base)				13.0%			13.0%	13.0%	13.0%	13.0%	13.0%
x		Base Zinc Price \$US/lb				\$0.635			0.64	0.64	0.64	0.64	0.64
Net Smelter Return (NSR)													
TRANSPORTATION													
x		Mine to Port		Cdn\$/wmt		\$181.86			181.86	181.86	181.86	181.86	181.86
x		Storage and Vessel Loading		Cdn\$/wmt		\$0.00			-	-	-	-	-
		Land + Ocean Freight		US\$/wmt		\$0.00			-	-	-	-	-
x		Representation		US\$/wmt		\$0.50			0.50	0.50	0.50	0.50	0.50
x		Insurance		% NIV		0.15%			0.15%	0.15%	0.15%	0.15%	0.15%
x		Losses		% NIV		0.50%			0.50%	0.50%	0.50%	0.50%	0.50%
x		Moisture		%		8%			8.0%	8.0%	8.0%	8.0%	8.0%
Penalties													
Lead Concentrate Penalties													
x		Antimony	Penalty Charge	US\$/dmt		\$1.50			\$1.50	\$1.50	\$1.50	\$1.50	\$1.50
x			Grade in Concentration	ppm		5900			5900	5900	5900	5900	5900
x			Penalty Increment	ppm		1000			1000	1000	1000	1000	1000
x			Threshold	ppm		1000			1000	1000	1000	1000	1000
		Arsenic	Penalty Charge	US\$/dmt		\$1.50			\$1.50	\$1.50	\$1.50	\$1.50	\$1.50
x			Grade in Concentration	ppm		270			270	270	270	270	270
x			Penalty Increment	ppm		1000.0			1000	1000	1000	1000	1000
x			Threshold	ppm		5000.0			5000	5000	5000	5000	5000
		Lead	Penalty Charge	US\$/dmt		\$0.00			\$0.00	\$0.00	\$0.00	\$0.00	\$0.00
x			Grade in Concentration	%		0.00%			0.00%	0.00%	0.00%	0.00%	0.00%
x			Penalty Increment	%		0%			0%	0%	0%	0%	0%
x			Threshold	%		0%			0%	0%	0%	0%	0%
		Mercury	Penalty Charge	US\$/dmt		\$1.00			\$1.00	\$1.00	\$1.00	\$1.00	\$1.00
x			Grade in Concentration	ppm		2			2	2	2	2	2

				Units	Source	Input	Year -2	Year -1	Year 1	Year 2	Year 3	Year 4	Year 5
x			Penalty Increment	ppm		10			10	10	10	10	10
x			Threshold	ppm		50			50	50	50	50	50
x		Selenium	Penalty Charge	US\$/dmt	No Data	\$0.00			\$0.00	\$0.00	\$0.00	\$0.00	\$0.00
x			Grade in Concentration	ppm		30			30	30	30	30	30
x			Penalty Increment	ppm		1			1	1	1	1	1
x			Threshold	ppm		0			0	0	0	0	0
x		Zinc	Penalty Charge	US\$/dmt		\$1.00			\$1.00	\$1.00	\$1.00	\$1.00	\$1.00
x			Grade in Concentration	%		4.87%			4.87%	4.87%	4.87%	4.87%	4.87%
x			Penalty Increment	%		1%			1%	1%	1%	1%	1%
x			Threshold	%		8%			8%	8%	8%	8%	8%
		Zinc Concentrate Penalties											
x		Antimony	Penalty Charge	US\$/dmt		3			\$3.00	\$3.00	\$3.00	\$3.00	\$3.00
x			Grade in Concentration	ppm		680			680	680	680	680	680
x			Penalty Increment	ppm		1000			1000	1000	1000	1000	1000
x			Threshold	ppm		1000			1000	1000	1000	1000	1000
x		Arsenic	Penalty Charge	US\$/dmt		\$ 2.00			\$2.00	\$2.00	\$2.00	\$2.00	\$2.00
x			Grade in Concentration	ppm		140			140	140	140	140	140
x			Penalty Increment	ppm		1000			1000	1000	1000	1000	1000
x			Threshold	ppm		1000			1000	1000	1000	1000	1000
x		Cadmium	Penalty Charge	US\$/dmt		\$ 1.00			\$1.00	\$1.00	\$1.00	\$1.00	\$1.00
x			Grade in Concentration	ppm		6600			6600	6600	6600	6600	6600
x			Penalty Increment	ppm		1000			1000	1000	1000	1000	1000
x			Threshold	ppm		3000			3000	3000	3000	3000	3000
x		Fluorine	Penalty Charge	US\$/dmt		1			\$1.00	\$1.00	\$1.00	\$1.00	\$1.00
x			Grade in Concentration	ppm		50			50	50	50	50	50
x			Penalty Increment	ppm		120			120	120	120	120	120
x			Threshold	ppm		150			150	150	150	150	150
x		Iron	Penalty Charge	US\$/dmt		\$ 1.50			\$1.50	\$1.50	\$1.50	\$1.50	\$1.50
x			Grade in Concentration	%		8.00%			8.00%	8.00%	8.00%	8.00%	8.00%
x			Penalty Increment	%		1%			1%	1%	1%	1%	1%
x			Threshold	%		8.00%			8%	8%	8%	8%	8%
x		Mercury	Penalty Charge	US\$/dmt		\$ 3.50			\$3.50	\$3.50	\$3.50	\$3.50	\$3.50
x			Grade in Concentration	ppm		13			13	13	13	13	13
x			Penalty Increment	ppm		125			125	125	125	125	125
x			Threshold	ppm		30			30	30	30	30	30
x		Selenium	Penalty Charge	US\$/dmt		\$ 1.00			\$1.00	\$1.00	\$1.00	\$1.00	\$1.00
x			Grade in Concentration	ppm		30			30	30	30	30	30
x			Penalty Increment	ppm		100			100	100	100	100	100
x			Threshold	ppm		300			300	300	300	300	300
		Capital Cost Estimate											
		All Capital Costs are taken into account in SW+99 Financial Model											

LEAD CONCENTRATE CALCULATIONS										
	Unit	Year -2	Year -1	Year 1	Year 2	Year 3	Year 4	Year 5	AVG	TOTAL
MILL PRODUCTION										
Tonnes Ore Mined & Milled	000's t			0	0	55	55	96		
Zinc Grade	%			19.000%	19.000%	19.000%	19.000%	19.000%		
Lead Grade	%			1.800%	1.800%	1.800%	1.800%	1.800%		
Gold Grade	g/t			0.551	0.551	0.551	0.551	0.551		
Silver Grade	g/t			231.485	231.485	231.485	231.485	231.485		
Lead Recovery	%			80.00%	80.00%	80.00%	80.00%	80.00%		
Recovered Lead	000's lbs			0	0	1,738	1,738	3,038		
Recovered Lead	000's t			0.000	0.000	0.788	0.788	1.378		
Zinc Recovery	%			0.08%	0.08%	0.08%	0.08%	0.08%		
Recovered Zinc	000's lbs			0	0	18	18	32		
Recovered Zinc	000's t			0.000	0.000	0.008	0.008	0.015		
Silver Recovery	%			72.20%	72.20%	72.20%	72.20%	72.20%		
Recovered Silver	000's oz			0.0	0.0	294.2	294.2	514.3		
Gold Recovery	%			41.50%	41.50%	41.50%	41.50%	41.50%		
Recovered Gold	000's oz			0.0	0.0	0.4	0.4	0.7		
CONCENTRATE GRADE										
Lead	%			60.00%	60.00%	60.00%	60.00%	60.00%		
Zinc	%			6.00%	6.00%	6.00%	6.00%	6.00%		
Silver	g/t			7020.621	7020.621	7020.621	7020.621	7020.621		
Gold	g/t			10.472	10.472	10.472	10.472	10.472		
Concentrate Moisture Content	%			8.0%	8.0%	8.0%	8.0%	8.0%		
DRY CONCENTRATE TONNAGE	dmt			0	0	1,314	1,314	2,297		
RATIO OF CONCENTRATION				0.00	0.00	41.67	41.67	41.67		
WET CONCENTRATE TONNAGE	wmt			0	0	1,428	1,428	2,497		

NET INVOICE VALUE (NIV) - Gross Value less Treatment Terms								
	Unit	Year -2	Year -1	Year 1	Year 2	Year 3	Year 4	Year 5
MILL PRODUCTION								
DRY CONCENTRATE TONNAGE	dmt			0	0	1,314	1,314	2,297
Head Grades								
Zinc	%			19.000%	19.000%	19.000%	19.000%	19.000%
Lead	%			1.800%	1.800%	1.800%	1.800%	1.800%
Gold	g/t			0.551	0.551	0.551	0.551	0.551
Silver	g/t			231.485	231.485	231.485	231.485	231.485
Recoveries								
Zinc	%			0.08%	0.08%	0.08%	0.08%	0.08%
Lead	%			80.00%	80.00%	80.00%	80.00%	80.00%
Gold	%			41.50%	41.50%	41.50%	41.50%	41.50%
Silver	%			72.20%	72.20%	72.20%	72.20%	72.20%
CONCENTRATE GRADE								
Zinc	%			6.00%	6.00%	6.00%	6.00%	6.00%
Lead	%			60.00%	60.00%	60.00%	60.00%	60.00%
Gold	g/t			10.472	10.472	10.472	10.472	10.472
Silver	g/t			7020.621	7020.621	7020.621	7020.621	7020.621
CONTAINED METAL								
Zinc	lbs/dmt			132.276	132.276	132.276	132.276	132.276
Lead	lbs/dmt			1322.760	1322.760	1322.760	1322.760	1322.760
Gold	oz/dmt			0.337	0.337	0.337	0.337	0.337
Silver	oz/dmt			225.718	225.718	225.718	225.718	225.718
ACCOUNTABLE METAL								
Zinc	lbs/dmt			0.000	0.000	0.000	0.000	0.000
Lead	lbs/dmt			1256.622	1256.622	1256.622	1256.622	1256.622
Gold	oz/dmt			0.327	0.327	0.327	0.327	0.327
Silver	oz/dmt			203.146	203.146	203.146	203.146	203.146
METAL PRICES								
Zinc	US\$/lb			1.24	1.24	1.24	1.24	1.24
Lead	US\$/lb			0.81	0.81	0.81	0.81	0.81
Gold	US\$/oz			625.59	625.59	625.59	625.59	625.59
Silver	US\$/oz			11.69	11.69	11.69	11.69	11.69
GROSS CONCENTRATE VALUE								
Zinc	US\$/dmt			0.00	0.00	0.00	0.00	0.00
Lead	US\$/dmt			1,021.01	1,021.01	1,021.01	1,021.01	1,021.01
Gold	US\$/dmt			204.30	204.30	204.30	204.30	204.30
Silver	US\$/dmt			2,374.98	2,374.98	2,374.98	2,374.98	2,374.98
SUBTOTAL	US\$/dmt			3,600.29	3,600.29	3,600.29	3,600.29	3,600.29
TREATMENT TERMS								
Smelting								
Zinc	US\$/dmt			0.00	0.00	0.00	0.00	0.00
Lead	US\$/dmt			39.70	39.70	39.70	39.70	39.70

Zinc in lead is penalty and vice versa

NET SMELTER RETURN (NSR) - Net Invoice Value less Transportation Costs, Losses, Insurance, and Representation									
	Unit	Year -2	Year -1	Year 1	Year 2	Year 3	Year 4	Year 5	
MILL PRODUCTION									
DRY CONCENTRATE TONNAGE	dmt			0	0	1,314	1,314	2,297	
WET CONCENTRATE TONNAGE	wmt			0	0	1,428	1,428	2,497	
NIV VALUE	US\$/dmt			0.00	0.00	3,294.59	3,294.59	3,294.59	
TRANSPORTATION									
Mine to Port	US\$/dmt			0.00	0.00	176.28	176.28	176.28	
Storage and Vessel Loading	US\$/dmt			0.00	0.00	0.00	0.00	0.00	
Land + Ocean Freight	US\$/dmt			0.00	0.00	0.00	0.00	0.00	
Representation	US\$/dmt			0.00	0.00	0.54	0.54	0.54	
Insurance	US\$/dmt			0.00	0.00	0.00	0.00	0.00	
Losses	US\$/dmt			0.00	0.00	0.01	0.01	0.01	
SUBTOTAL	US\$/dmt			0.00	0.00	176.83	176.83	176.83	
NSR UNIT VALUE	US\$/dmt			0.00	0.00	3,117.76	3,117.76	3,117.76	
NSR VALUE	000's US\$			0	0	4,097	4,097	7,161	
Transport cost by METAL CONTRIBUTION									
Zinc	US\$/dmt			0.00	0.00	0.00	0.00	0.00	
Lead	US\$/dmt			0.00	0.00	50.15	50.15	50.15	
Gold	US\$/dmt			0.00	0.00	10.03	10.03	10.03	
Silver	US\$/dmt			0.00	0.00	116.65	116.65	116.65	
Net Smelter Return Unit Value by METAL CONTRIBUTION									
Zinc	US\$/dmt			0.00	0.00	0.00	0.00	0.00	
Lead	US\$/dmt			896.01	896.01	845.86	845.86	845.86	
Gold	US\$/dmt			194.40	194.40	184.37	184.37	184.37	
Silver	US\$/dmt			2,211.53	2,211.53	2,094.88	2,094.88	2,094.88	
Total	US\$/dmt			3,301.94	3,301.94	3,125.11	3,125.11	3,125.11	
% Contribution NSR by METAL									
Zinc	%			0.0%	0.0%	0.0%	0.0%	0.0%	
Lead	%			27.1%	27.1%	27.1%	27.1%	27.1%	
Gold	%			5.9%	5.9%	5.9%	5.9%	5.9%	
Silver	%			67.0%	67.0%	67.0%	67.0%	67.0%	
Total	%			100.0%	100.0%	100.0%	100.0%	100.0%	

ZINC CONCENTRATE CALCULATIONS									
	Unit	Year -2	Year -1	Year 1	Year 2	Year 3	Year 4	Year 5	TOTAL
MILL PRODUCTION									
Tonnes Ore Mined & Milled	000's t			0	0	55	55	96	205
Zinc Grade	%			19.000%	19.000%	19.000%	19.000%	19.000%	
Lead Grade	%			1.800%	1.800%	1.800%	1.800%	1.800%	
Gold Grade	g/t			0.551	0.551	0.551	0.551	0.551	
Silver Grade	g/t			231.485	231.485	231.485	231.485	231.485	
Lead Recovery	%			7.40%	7.40%	7.40%	7.40%	7.40%	
Recovered Lead	000's lbs			0	0	161	161	281	
Recovered Lead	000's t			0.000	0.000	0.073	0.073	0.127	
Zinc Recovery	%			96.00%	96.00%	96.00%	96.00%	96.00%	
Recovered Zinc	000's lbs			0	0	22,016	22,016	38,484	82,516
Recovered Zinc	000's t			0.000	0.000	9.986	9.986	17.456	37.429
Gold Recovery	%			18.10%	18.10%	18.10%	18.10%	18.10%	
Recovered Gold	000's oz			0.0	0.0	0.2	0.2	0.3	
Silver Recovery	%			8.50%	8.50%	8.50%	8.50%	8.50%	
Recovered Silver	000's oz			0.0	0.0	34.6	34.6	60.5	
CONCENTRATE GRADE									
Zinc	%			55.00%	55.00%	55.00%	55.00%	55.00%	
Lead	%			0.40%	0.40%	0.40%	0.40%	0.40%	
Gold	g/t			0.331	0.331	0.331	0.331	0.331	
Silver	g/t			59.525	59.525	59.525	59.525	59.525	
Concentrate Moisture Content	%			8.0%	8.0%	8.0%	8.0%	8.0%	
DRY CONCENTRATE TONNAGE	dmt	0	0	0	0	18,157	18,157	31,739	68,053
RATIO OF CONCENTRATION		0.00	0.00	0.00	0.00	3.02	3.02	3.02	
WET CONCENTRATE TONNAGE	wmt	0	0	0	0	19,736	19,736	34,499	73,971

NET INVOICE VALUE (NIV) - Gross Value less Treatment Terms									
	Unit	Year -2	Year -1	Year 1	Year 2	Year 3	Year 4	Year 5	
MILL PRODUCTION									
DRY CONCENTRATE TONNAGE	dmt	0	0	0	0	18,157	18,157	31,739	
Head Grades									
Zinc	%			19.000%	19.000%	19.000%	19.000%	19.000%	
Lead	%			1.800%	1.800%	1.800%	1.800%	1.800%	
Gold	g/t			0.551	0.551	0.551	0.551	0.551	
Silver	g/t			231.485	231.485	231.485	231.485	231.485	
Recoveries									
Zinc	%			96.00%	96.00%	96.00%	96.00%	96.00%	
Lead	%			7.40%	7.40%	7.40%	7.40%	7.40%	
Gold	%			18.10%	18.10%	18.10%	18.10%	18.10%	
Silver	%			8.50%	8.50%	8.50%	8.50%	8.50%	
CONCENTRATE GRADE									
Zinc	%			55.00%	55.00%	55.00%	55.00%	55.00%	
Lead	%			0.40%	0.40%	0.40%	0.40%	0.40%	
Gold	g/t			0.331	0.331	0.331	0.331	0.331	
Silver	g/t			59.525	59.525	59.525	59.525	59.525	
CONTAINED METAL									
Zinc	lbs/dmt			1212.530	1212.530	1212.530	1212.530	1212.530	
Lead	lbs/dmt			8.818	8.818	8.818	8.818	8.818	
Gold	oz/dmt			0.011	0.011	0.011	0.011	0.011	
Silver	oz/dmt			1.914	1.914	1.914	1.914	1.914	
ACCOUNTABLE METAL									
Zinc	lbs/dmt			1030.651	1030.651	1030.651	1030.651	1030.651	
Lead	lbs/dmt			0.000	0.000	0.000	0.000	0.000	Lead in Zinc is considered Penalty
Gold	oz/dmt			0.010	0.010	0.010	0.010	0.010	
Silver	oz/dmt			1.244	1.244	1.244	1.244	1.244	
METAL PRICES									
Zinc	US\$/lb			1.24	1.24	1.24	1.24	1.24	
Lead	US\$/lb			0.81	0.81	0.81	0.81	0.81	
Gold	US\$/oz			625.59	625.59	625.59	625.59	625.59	
Silver	US\$/oz			11.69	11.69	11.69	11.69	11.69	
GROSS CONCENTRATE VALUE									
Zinc	US\$/dmt			1,276.98	1,276.98	1,276.98	1,276.98	1,276.98	
Lead	US\$/dmt			0.00	0.00	0.00	0.00	0.00	
Gold	US\$/dmt			6.45	6.45	6.45	6.45	6.45	
Silver	US\$/dmt			14.54	14.54	14.54	14.54	14.54	
SUBTOTAL	US\$/dmt			1,297.97	1,297.97	1,297.97	1,297.97	1,297.97	
TREATMENT TERMS									
Smelting									
Zinc	US\$/dmt			221.36	221.36	221.36	221.36	221.36	
Lead	US\$/dmt			0.00	0.00	0.00	0.00	0.00	

Gold	US\$/dmt			1.12	1.12	1.12	1.12	1.12			
Silver	US\$/dmt			2.52	2.52	2.52	2.52	2.52			
Total Smelting	US\$/dmt			225.00	225.00	225.00	225.00	225.00			
Refining											
Zinc	US\$/dmt			0.00	0.00	0.00	0.00	0.00			
Lead	US\$/dmt			0.00	0.00	0.00	0.00	0.00			
Gold	US\$/dmt			0.06	0.06	0.06	0.06	0.06			
Silver	US\$/dmt			0.44	0.44	0.44	0.44	0.44			
Price Escalation (Zinc)	US\$/dmt			99.60	99.60	99.60	99.60	99.60			
Subtotal Zinc	US\$/dmt			320.96	320.96	320.96	320.96	320.96			
Subtotal Lead	US\$/dmt			0.00	0.00	0.00	0.00	0.00			
Subtotal Gold	US\$/dmt			1.18	1.18	1.18	1.18	1.18			
Subtotal Silver	US\$/dmt			2.96	2.96	2.96	2.96	2.96			
Total Treatment Terms	US\$/dmt			325.10	325.10	325.10	325.10	325.10			
Treatment Cost per tonne				N/A	N/A	107.81	107.81	107.81			
METAL PENALTIES											
Antimony	US\$/dmt			\$ -	\$ -	\$ -	\$ -	\$ -			
Arsenic	US\$/dmt			\$ -	\$ -	\$ -	\$ -	\$ -			
Cadmium	US\$/dmt			\$ 3.60	\$ 3.60	\$ 3.60	\$ 3.60	\$ 3.60			
Fluorine	US\$/dmt			\$ -	\$ -	\$ -	\$ -	\$ -			
Iron	US\$/dmt			\$ -	\$ -	\$ -	\$ -	\$ -			
Mercury	US\$/dmt			\$ -	\$ -	\$ -	\$ -	\$ -			
Mercury	US\$/dmt			\$ -	\$ -	\$ -	\$ -	\$ -			
Selenium	US\$/dmt			\$ -	\$ -	\$ -	\$ -	\$ -			
NET INVOICE UNIT VALUE	US\$/dmt			0.00	0.00	969.27	969.27	969.27			
NET INVOICE VALUE	000's US\$			0.00	0.00	17,599.15	17,599.15	30,763.63			
Net Invoice Unit Value by METAL CONTRIBUTION											
Zinc	US\$/dmt			952.41	952.41	952.41	952.41	952.41			
Lead	US\$/dmt			0.00	0.00	0.00	0.00	0.00			
Gold	US\$/dmt			5.27	5.27	5.27	5.27	5.27			
Silver	US\$/dmt			11.59	11.59	11.59	11.59	11.59			
SUBTOTAL	US\$/dmt			969.27	969.27	969.27	969.27	969.27			
% Gross Contribution											
	Zinc			98.4%	98.4%	98.4%	98.4%	98.4%			
	Lead			0.0%	0.0%	0.0%	0.0%	0.0%			
	Gold			0.5%	0.5%	0.5%	0.5%	0.5%			
	Silver			1.1%	1.1%	1.1%	1.1%	1.1%			
	Total			100.0%	100.0%	100.0%	100.0%	100.0%			

NET SMELTER RETURN (NSR) - Net Invoice Value less Transportation Costs, Losses, Insurance, and Representati								
	Unit	Year -2	Year -1	Year 1	Year 2	Year 3	Year 4	Year 5
MILL PRODUCTION								
DRY CONCENTRATE TONNAGE	dmt			0	0	18,157	18,157	31,739
WET CONCENTRATE TONNAGE	wmt			0	0	19,736	19,736	34,499
NIV VALUE	US\$/dmt			0.00	0.00	969.27	969.27	969.27
TRANSPORTATION (adjusted for moisture and currency)								
Mine to Port	US\$/dmt			0.00	0.00	176.28	176.28	176.28
Storage and Vessel Loading	US\$/dmt			0.00	0.00	0.00	0.00	0.00
Land + Ocean Freight	US\$/dmt			0.00	0.00	0.00	0.00	0.00
Representation	US\$/dmt			0.00	0.00	0.54	0.54	0.54
Insurance	US\$/dmt			0.00	0.00	0.00	0.00	0.00
Losses	US\$/dmt			0.00	0.00	0.01	0.01	0.01
SUBTOTAL	US\$/dmt			0.00	0.00	176.83	176.83	176.83
NSR UNIT VALUE	US\$/dmt			0.00	0.00	792.44	792.44	792.44
NSR VALUE	000's US\$			0	0	14,388	14,388	25,151
Transport cost by METAL CONTRIBUTION								
Zinc	US\$/dmt			0.00	0.00	173.97	173.97	173.97
Lead	US\$/dmt			0.00	0.00	0.00	0.00	0.00
Gold	US\$/dmt			0.00	0.00	0.88	0.88	0.88
Silver	US\$/dmt			0.00	0.00	1.98	1.98	1.98
Net Smelter Return Unit Value by METAL CONTRIBUTION								
Zinc	US\$/dmt			952.41	952.41	778.44	778.44	778.44
Lead	US\$/dmt			0.00	0.00	0.00	0.00	0.00
Gold	US\$/dmt			5.27	5.27	4.39	4.39	4.39
Silver	US\$/dmt			11.59	11.59	9.61	9.61	9.61
Total	US\$/dmt			969.27	969.27	792.44	792.44	792.44
% Contribution NSR by METAL								
Zinc	%			98.3%	98.3%	98.2%	98.2%	98.2%
Lead	%			0.0%	0.0%	0.0%	0.0%	0.0%
Gold	%			0.5%	0.5%	0.6%	0.6%	0.6%
Silver	%			1.2%	1.2%	1.2%	1.2%	1.2%
Total	%			100.0%	100.0%	100.0%	100.0%	100.0%

OPERATING COST									
	Unit	Year -2	Year -1	Year 1	Year 2	Year 3	Year 4	Year 5	TOTAL
MILL PRODUCTION									
Tonnes Mined (Waste)	000's t			0	0	0	0	0	0
Tonnes Mined (Ore)	000's t			0	0	55	55	96	205
Mining	Cdn\$/t mined			111.45	131.99	120.44	112.22	113.77	
Milling	Cdn\$/t milled			64.67	64.67	45.91	45.91	45.91	
General & Administration	Cdn\$/t milled			36.93	36.93	23.08	23.08	24.17	
TOTAL Operating Cost									
Underground Mining	000's Cdn\$			0	0	6,594	6,144	10,888	23,626
Milling	000's Cdn\$			0	0	2,514	2,514	4,394	9,421
General & Administration	000's Cdn\$			0	0	1,264	1,264	2,313	4,840
TOTAL OPERATING COST	000's Cdn\$			\$ -	\$ -	\$ 10,371.29	\$ 9,921.25	\$ 17,595.18	37,888
TOTAL OPERATING COST	000's USD\$			\$0.00	\$0.00	\$9,248.92	\$8,847.57	\$15,691.04	
Total Operating Cost	Cdn\$/t milled			0.00	0.00	189.43	181.21	183.85	

Silver Costs

		Year 1	Year 2	Year 3	Year 4	Year 5
COSTS - EAST ZONE						
Opcosts	USD 000's	\$0.00	\$ -	\$ 9,248.92	\$ 8,847.57	\$ 15,691.04
Royalty	USD 000's	\$ -	\$ -	\$ 243.09	\$ 243.09	\$ 424.93
Smelting , Refining, and TRPRT	USD 000's	\$0	\$0	\$9,813	\$9,813	\$17,153
Gross Metal Value from Zinc	USD 000's	\$0	\$0	\$23,186	\$23,186	\$40,530
Gross Metal Value from Lead	USD 000's	\$0	\$0	\$1,342	\$1,342	\$2,345
Silver Cost	USD 000's	\$ -	\$ -	\$ (5,222.75)	\$ (5,624.09)	\$ (9,605.70)

APPENDIX B

Geostatistical Data

Year	1975	1980	1984	1986	1994	1994	1995	1995	1996	1996	2006	2007	Total
Operator	UKHM	UKHM	UKHM	UKHM	WGM	WGM	WGM	WGM	WGM	WGM	Alexco	Alexco	
Drilling characteristics													
Number of Borehole	281	23	178	20	105	1	27	67	12	38	9	31	279
Borehole type			RP	DDH	RC	DDH	DDH	PC	DDH	PC	DDH	DDH	
Collar position	surface	surface		Surface	Surface	Underground	Underground	Underground	Underground	Underground	Surface	Surface	
Borehole numbers				BK86-01 to BK86-20	BKP-94-001 to BKP-94-175, gaps SMP94-001 to SMP94-004	BK_UD94001	BK_UD95001 to BK_UD95027	BKUP95-001 to BKUP95-039 BKUT95-001 to BKUT032	BK_UD96028 to BK_UD96039	BKUT96-032 to BKUT96-069	K-06-0011 to K-06-0038, gaps	K-07-0064 to K-07-0106, gaps	
Meterage (metres)	12,840	1,000	9,083	1,335	5,595	76	2,491	1,312	1,042	1,156	3,727	9,217	25,951
Drilling contractor					Stan Wolarek	Advanced	Advanced				Peak	Quest	
Core size				variable, NQ, BQ, and unknown	2 inch (5cm)	NQ	NQ	2 inch (5cm)			NQ2	HQ	
Core archive	Unknown	Unknown	Unknown	Unknown	Unknown	Unknown	Unknown	Unknown	Unknown	Unknown	Yes	Yes	
Photographs	Unknown	Unknown	Unknown	Unknown	Unknown	Unknown	Unknown	Unknown	Unknown	Unknown	Yes	Yes	
Borehole surveying													
Collar survey					yes						yes (Ashtech)	yes (Ashtech)	
Collar Azimuth/plunge				variable	variable	128.54°	variable	variable	variable	variable	variable, Azimuth between 297 and 310 degrees, dip -60 to -70 degrees	variable, Azimuth between 260 and 300 degrees, dip -45 to -90 degrees	
Surveyor					Logan Hind, Joe Clarke								
Downhole Surveying											Easy Shot on 60m intervals	Easy Shot on 30m intervals	
Core orientation					NA			NA		NA	No	No	
Sampling procedure													
Sampling procedure											well documented	well documented	
Sample Length				variable, 0.15 - 2.13m	chips (1.52m intervals)	variable, 0.21 - 1.22m	variable, 0.12 - 3.96m	chips (1.22m intervals)	variable, 0.15 - 2.13	chips (1.22m intervals)	variable, from ca. 0.4 to 3m	variable, from ca. 0.4 to 3m	
Number of samples				130	3,557	6	169	1,049	75	217	2,646	4,346	12,195
Assaying													
Sample preparation											Chemex	Chemex	
Standard inserted											Yes	Yes	
rate											every 15 to 25	every 15 to 26	
Blanks inserted											Yes	Yes	
rate											every 15 to 25	every 15 to 26	
Primary Laboratory					Northern Analytical Laboratories	Northern Analytical Laboratories	Northern Analytical Laboratories	Northern Analytical Laboratories			Chemex	Chemex	
number of samples											2,646	4,349	
Primary Ag assay					AAS	AAS	AAS	AAS			ME-ICP, AA, GRA	ME-ICP, AA, GRA	0
Replicate Ag assay					FA/Gravimetric	FA/Gravimetric	FA/Gravimetric	FA/Gravimetric					
Primary Pb assay					AAS	AAS	AAS	AAS			ME-ICP, AA, VOL	ME-ICP, AA, VOL	
Replicate Pb assay													
Primary Zn assay					AAS	AAS	AAS	AAS			ME-ICP, AA, VOL	ME-ICP, AA, VOL	
Replicate Zn assay													
Primary Cu assay					AAS	AAS	AAS	AAS			ME-ICP, AA	ME-ICP, AA	
Replicate Cu assay													
Primary Au assay					FA/AAS	FA/AAS	FA/AAS	FA/AAS			AA	AA	
Replicate Au assay													
Other assaying													
Original Certificates					yes	yes	yes	yes	yes	yes	yes	yes	
Secondary Laboratory					international Plasma Laboratories, Ltd (?)	international Plasma Laboratories, Ltd (?)							
number of samples						60							60
Primary Au assay					ICP	ICP							
Replicate Au assay													
Other assaying													
Original Certificates					Yes	Yes	Yes	Yes					

Time series control samples inserted with all samples submitted for assaying during the 2006 and 2007 drilling programs.

Sample blanks:

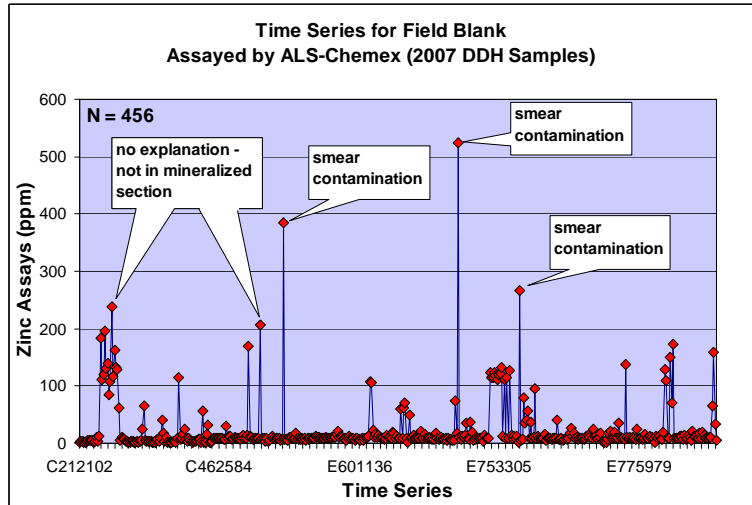
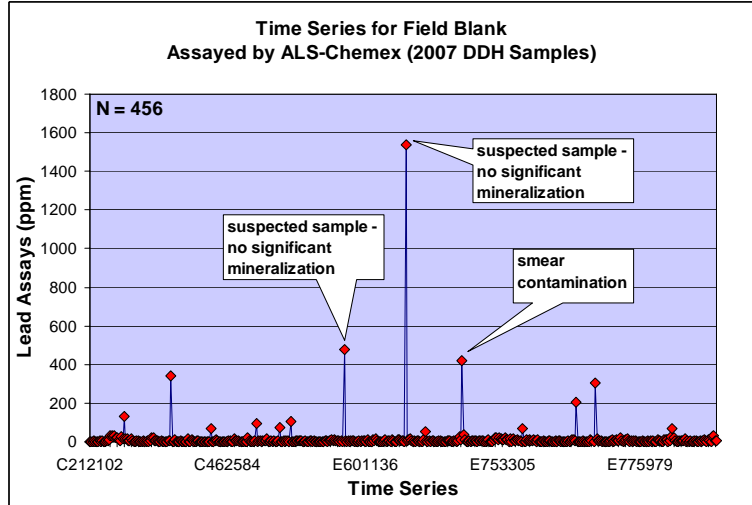
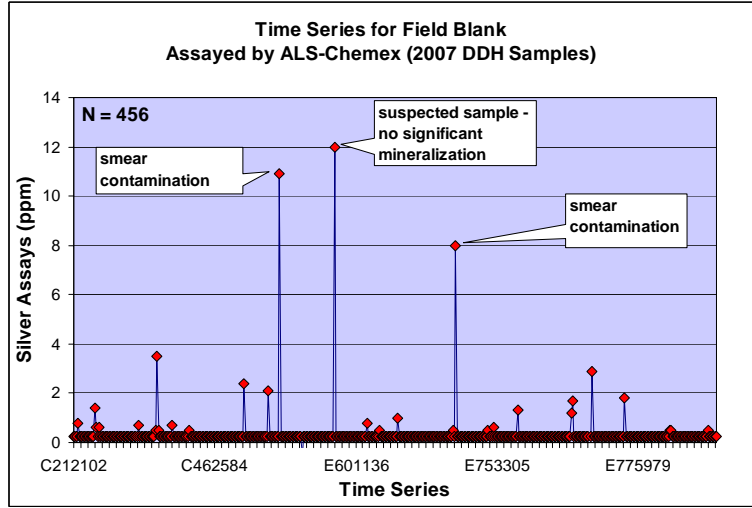

Polymetallic Control Sample PB111:

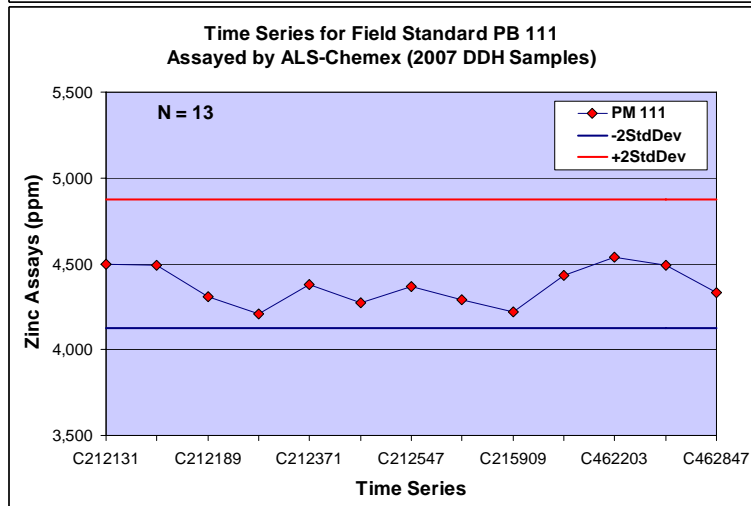
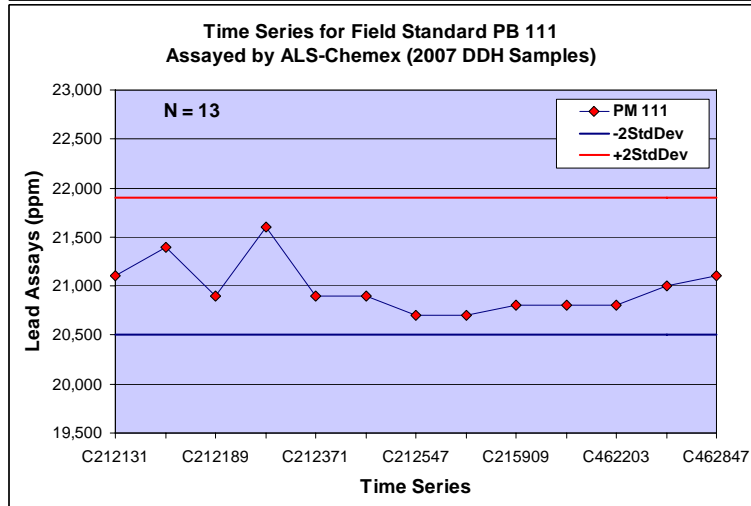
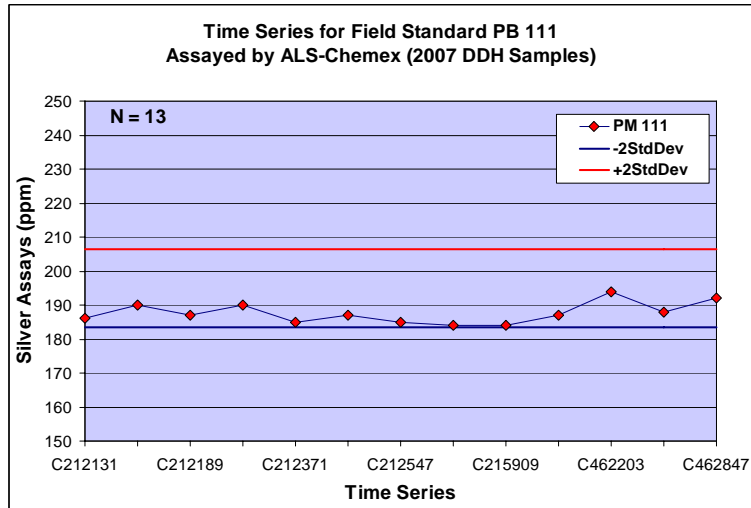

Polymetallic Control Sample PB112:

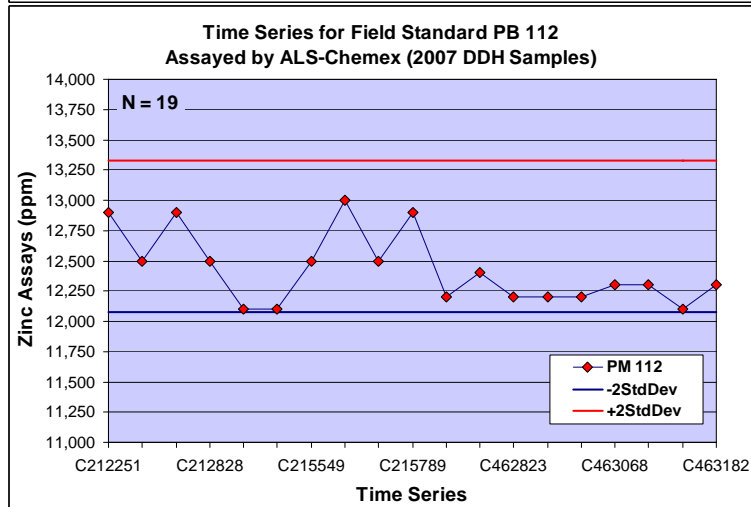
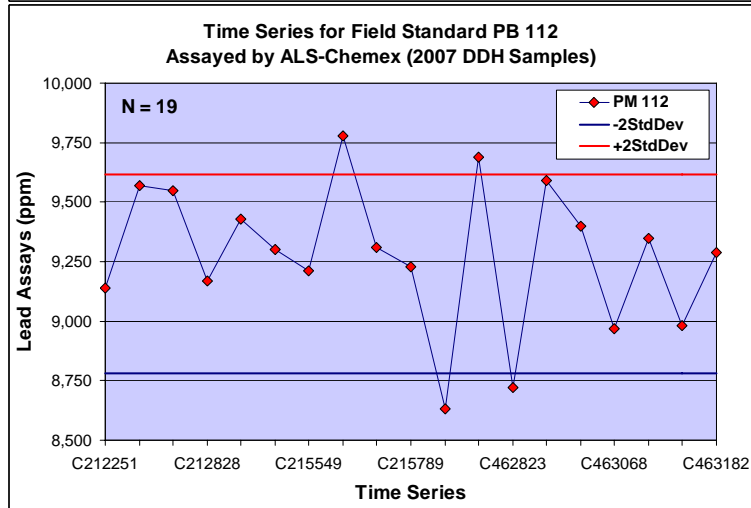
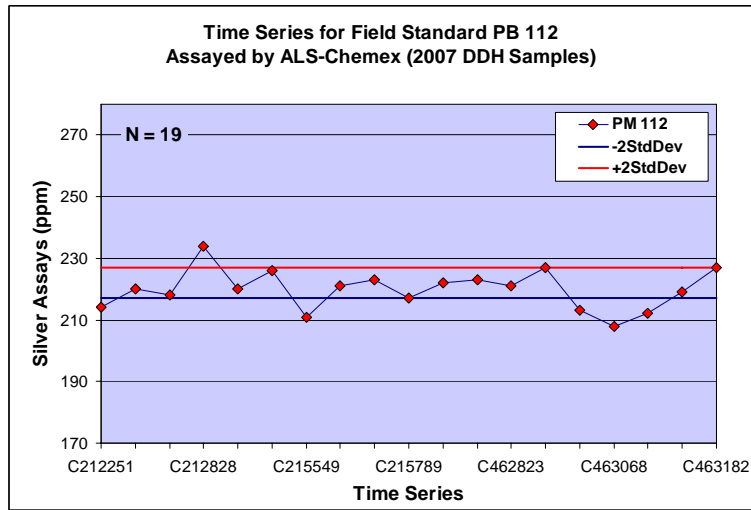

Polymetallic Control Sample PB113:

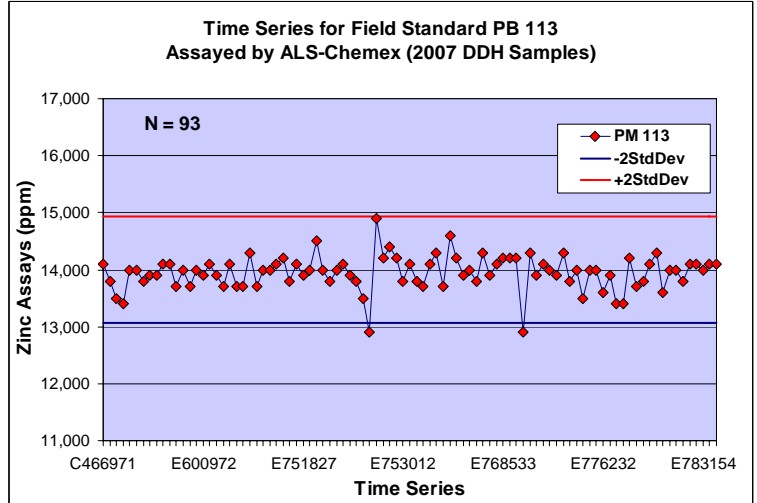
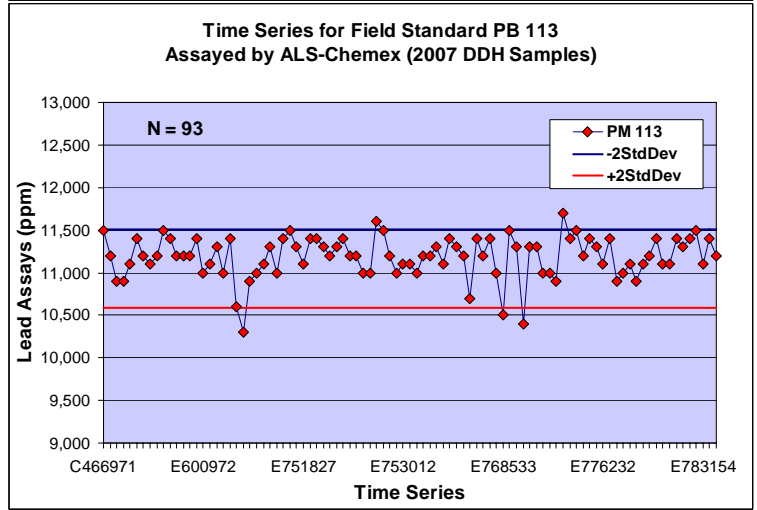
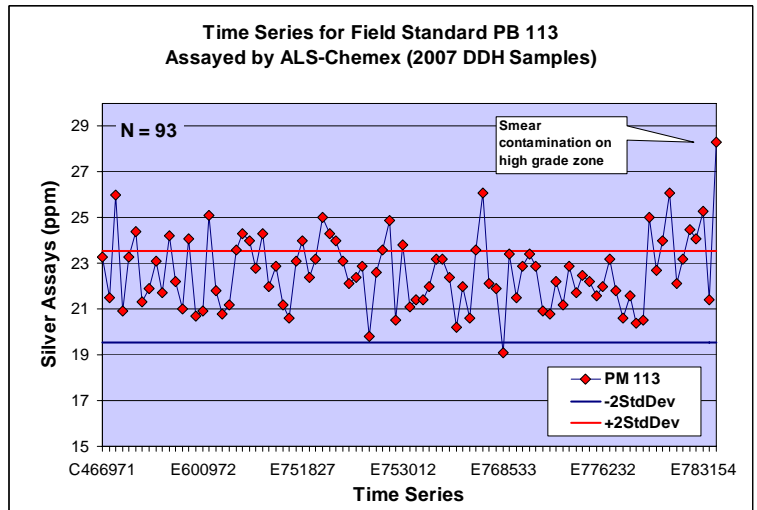

Polymetallic Control Sample PB116:

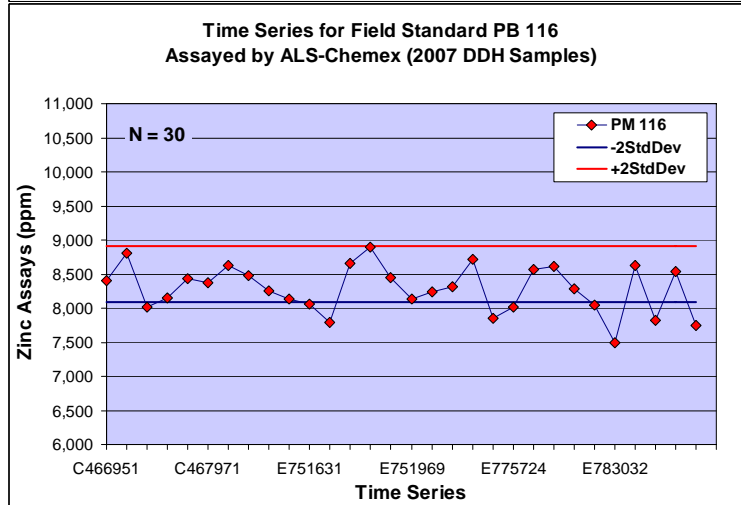
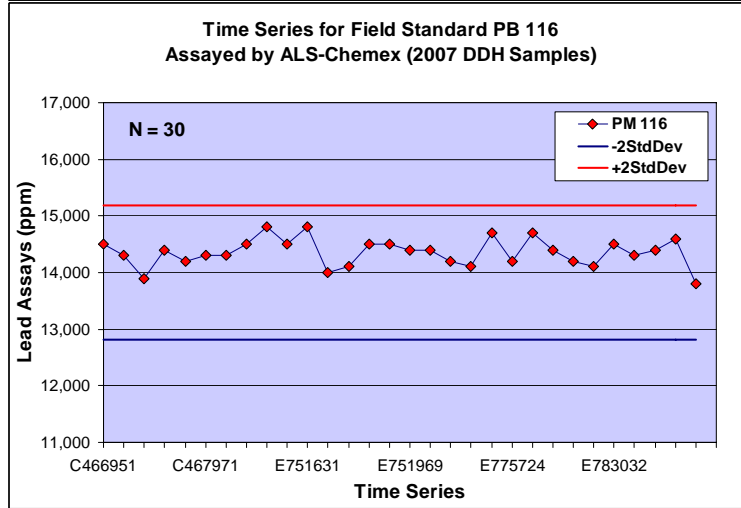
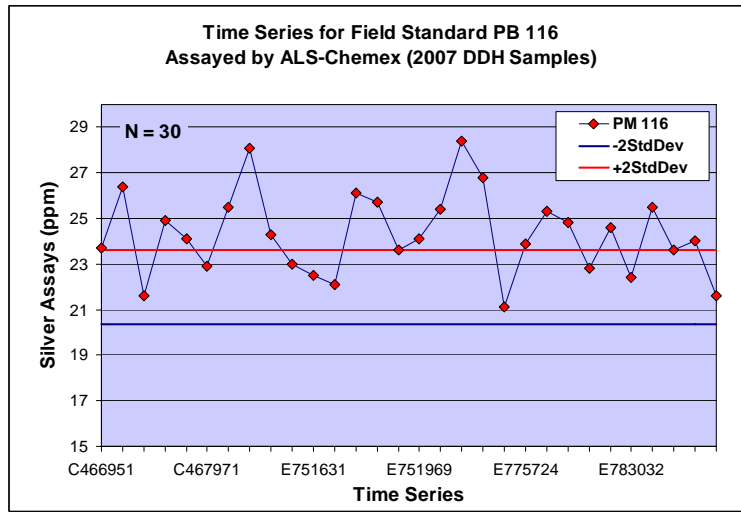

Silver Control Sample PM1117:

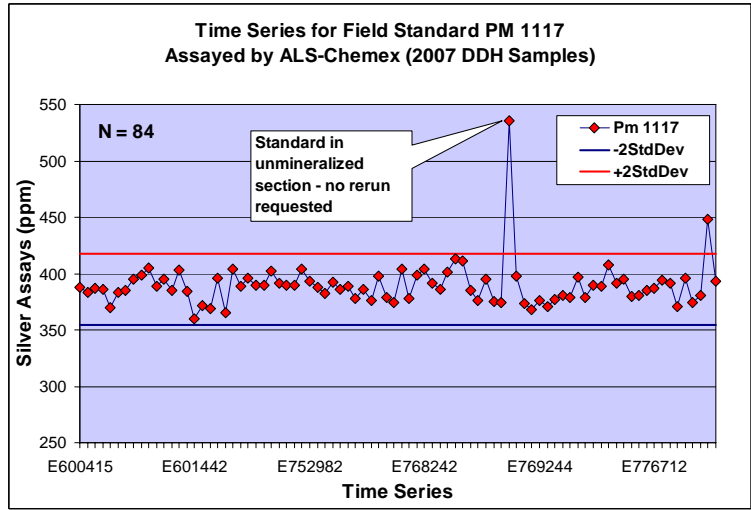
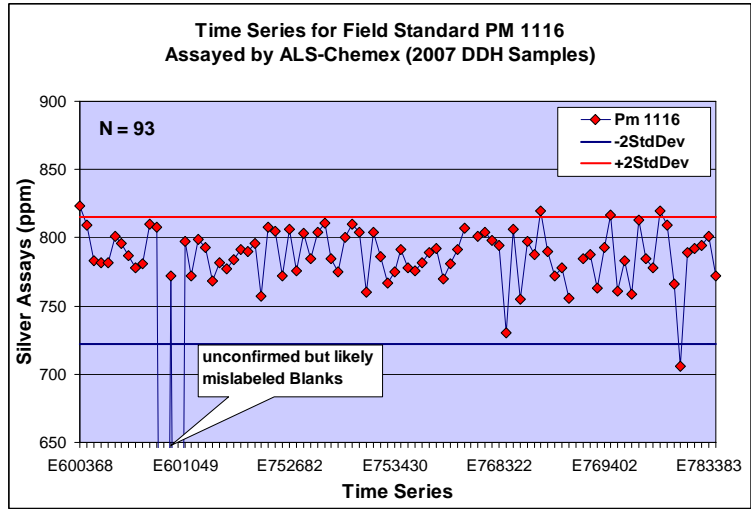

Bias Charts and Precision Plots for Silver Field Duplicate and Pulp Replicates Assay Pairs.

Field Duplicate Silver Assay Pairs

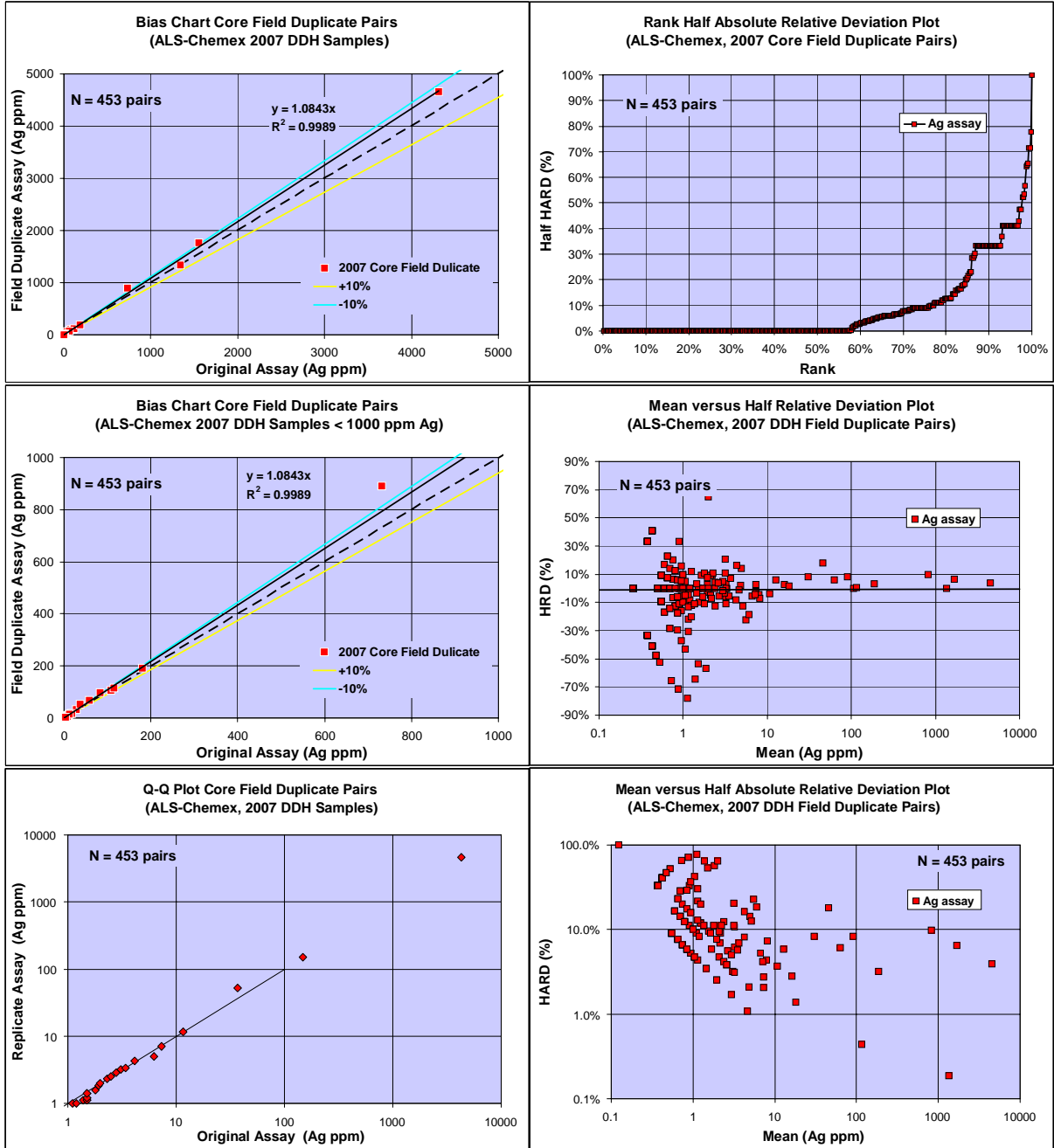

Pulp Replicate Silver Assay Pairs

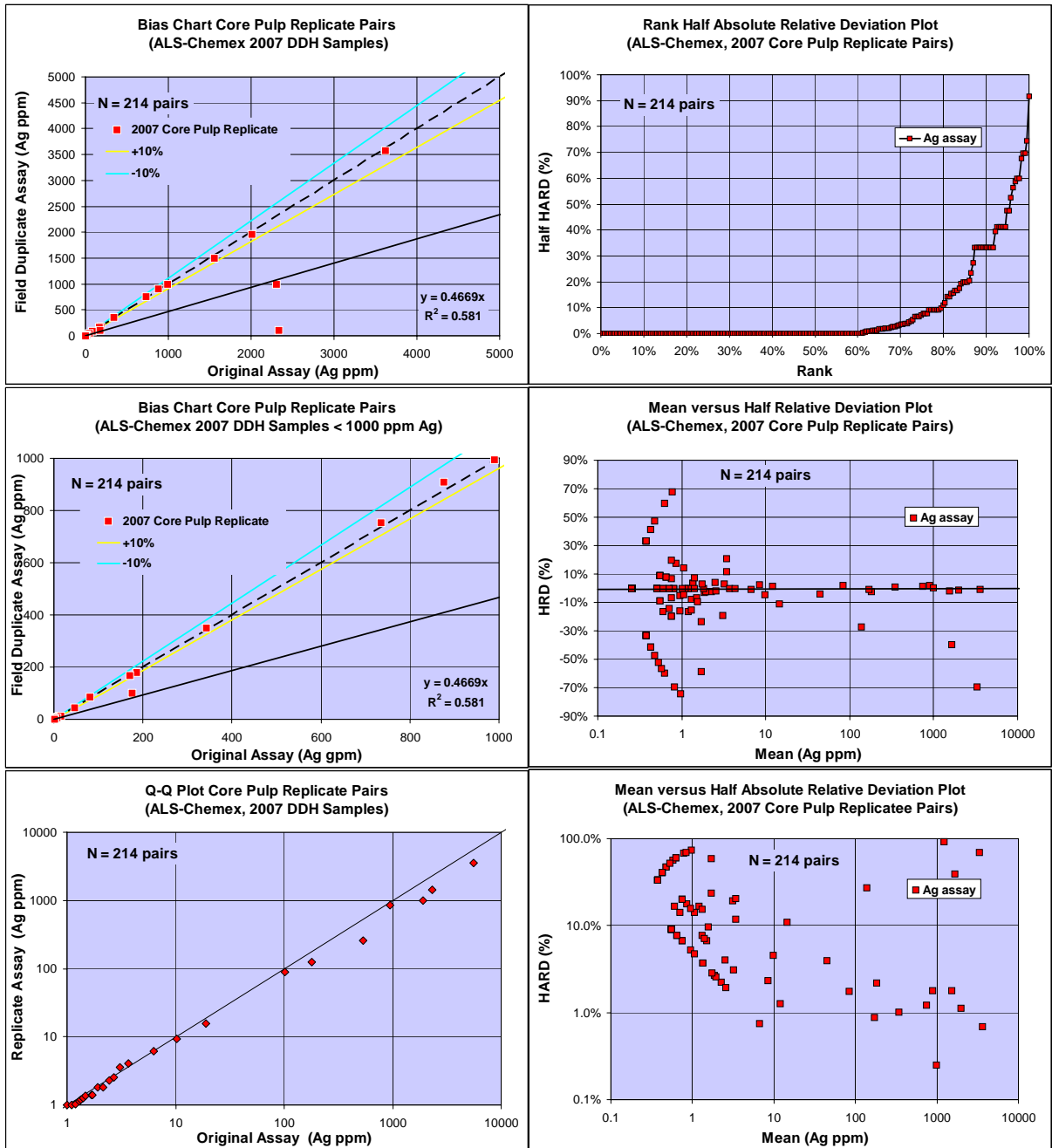

Field Duplicate Lead Assay Pairs

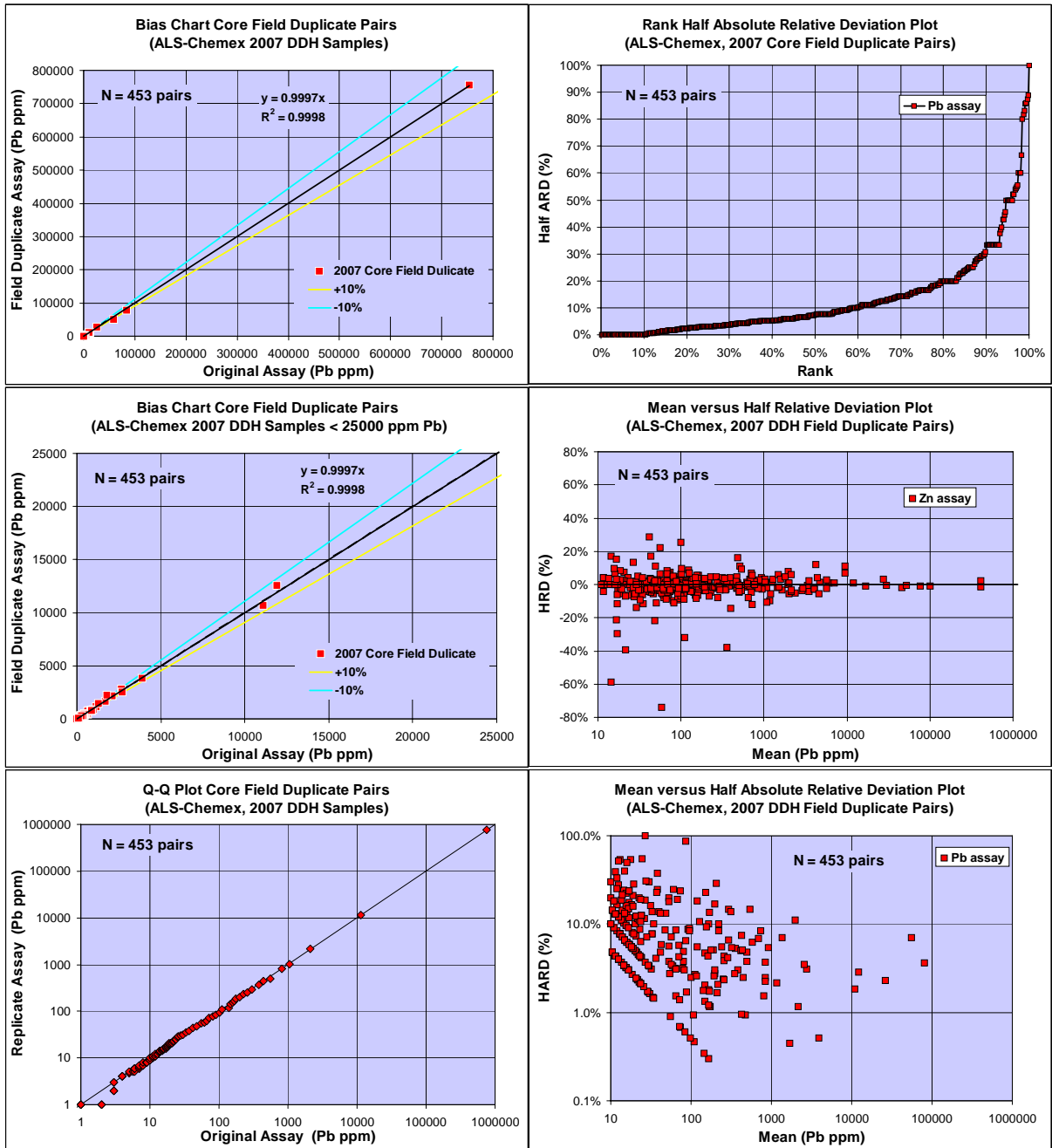

Pulp Replicate Lead Assay Pairs

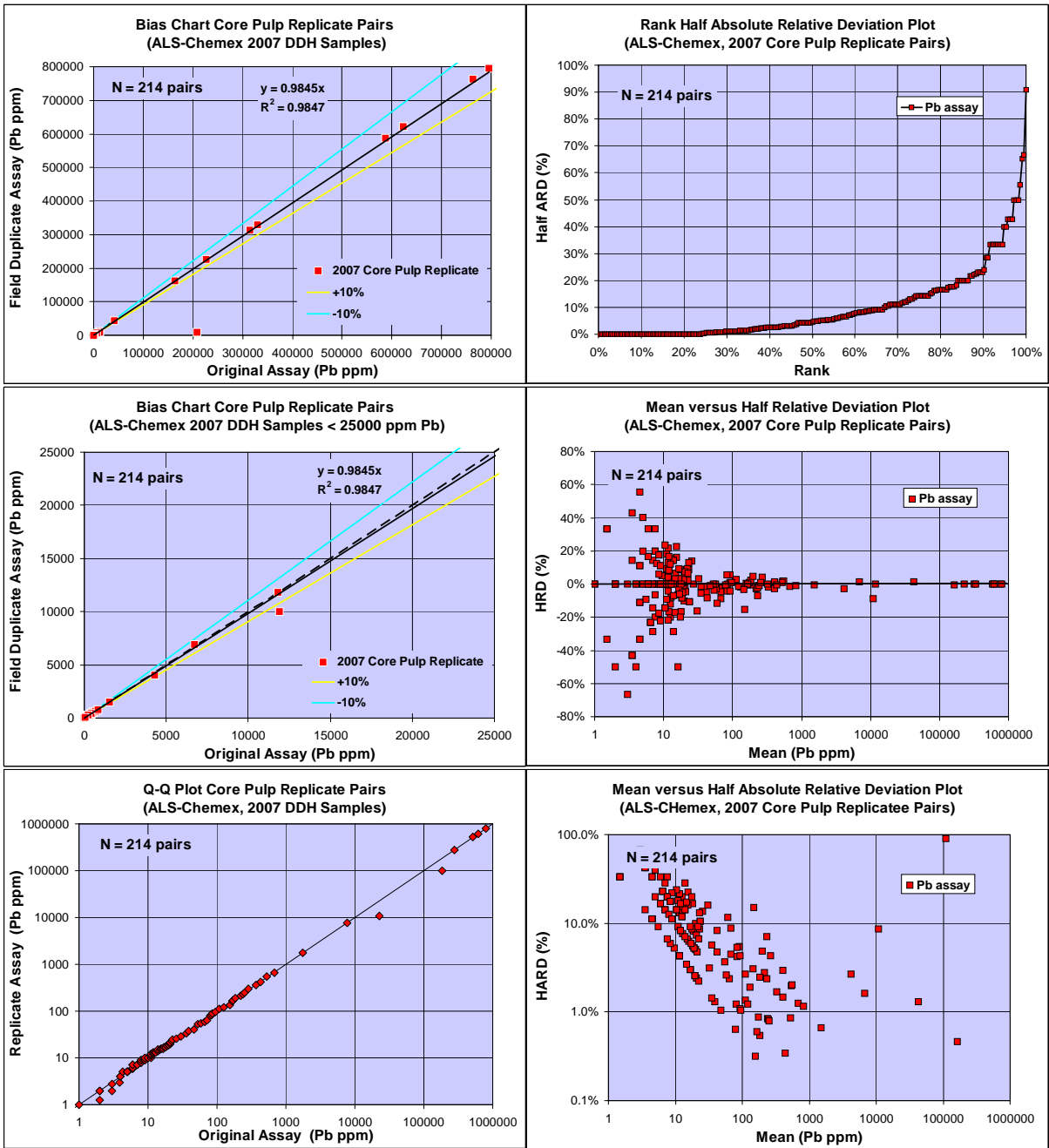

Field Duplicate Zinc Assay Pairs

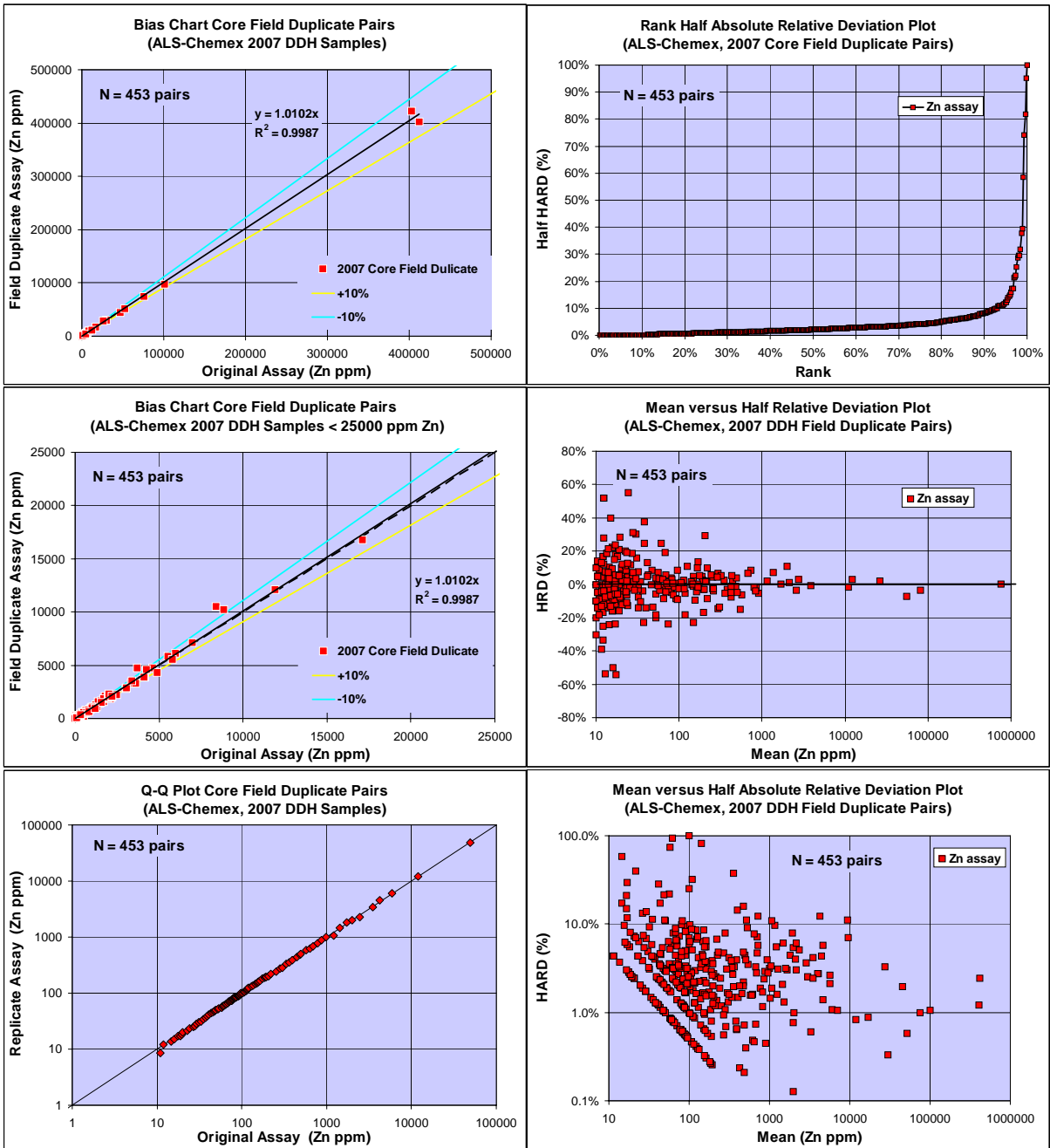

Pulp Replicate Zinc Assay Pairs

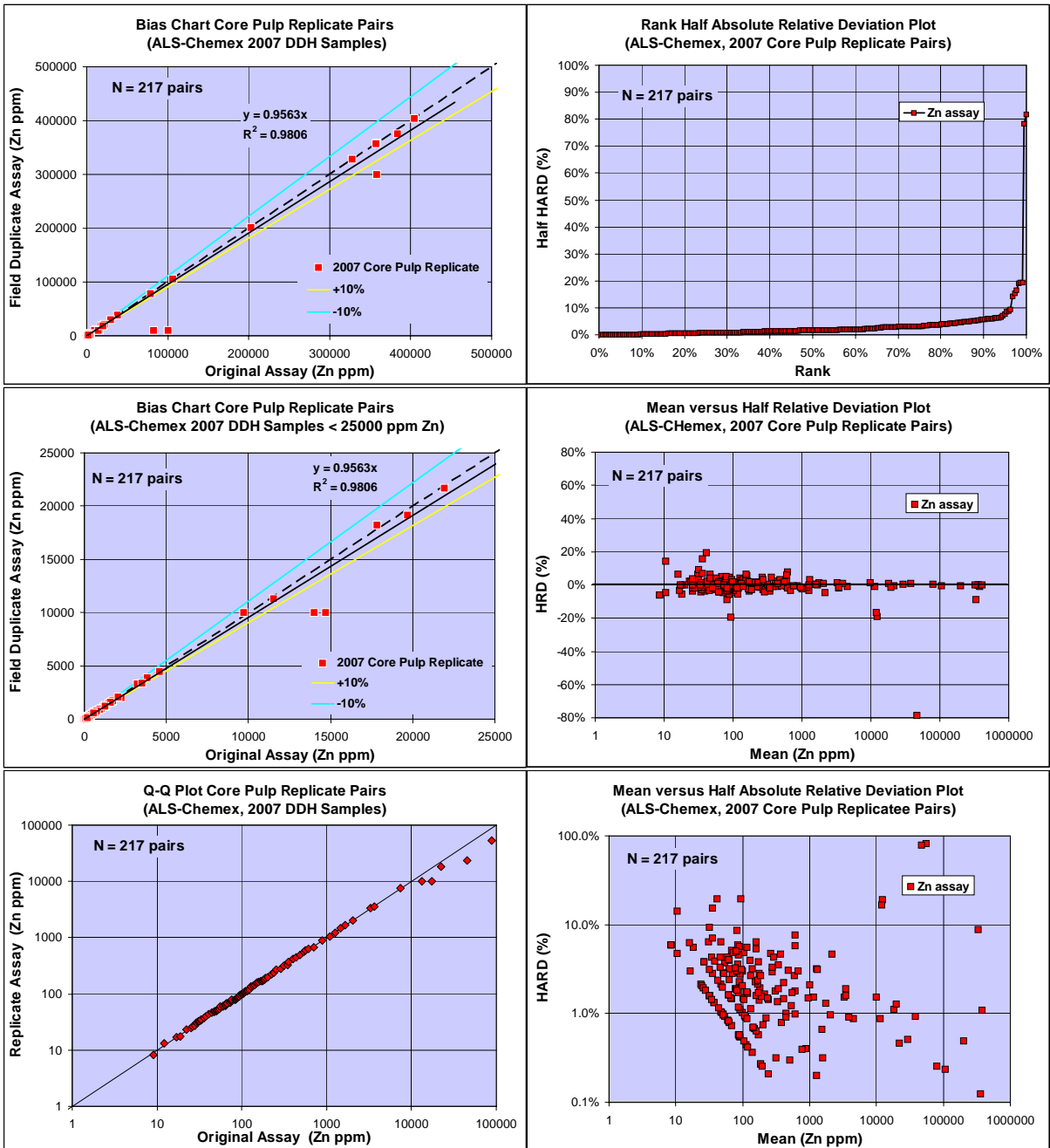

Cumulative frequency plot for gold composites (Southwest Zone).

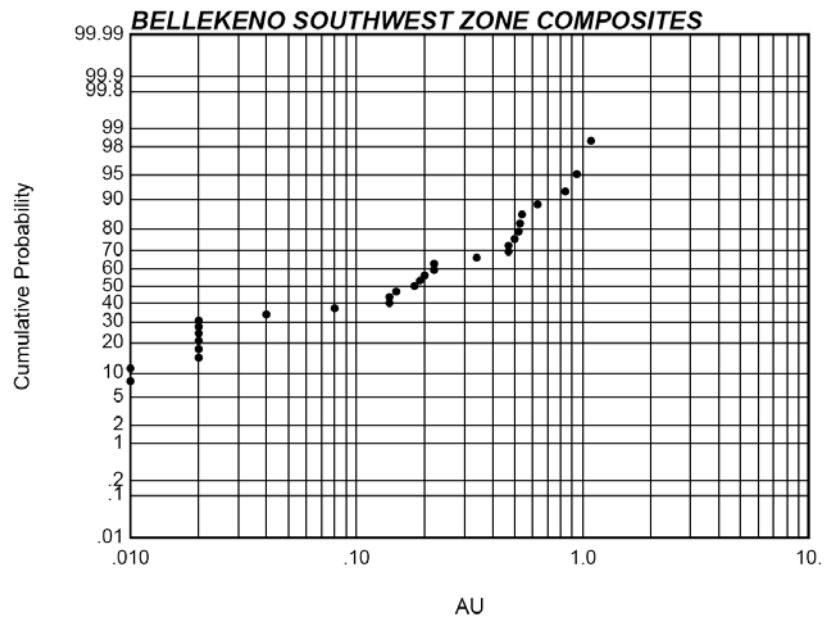

Cumulative frequency plot for zinc composites (Southwest Zone).

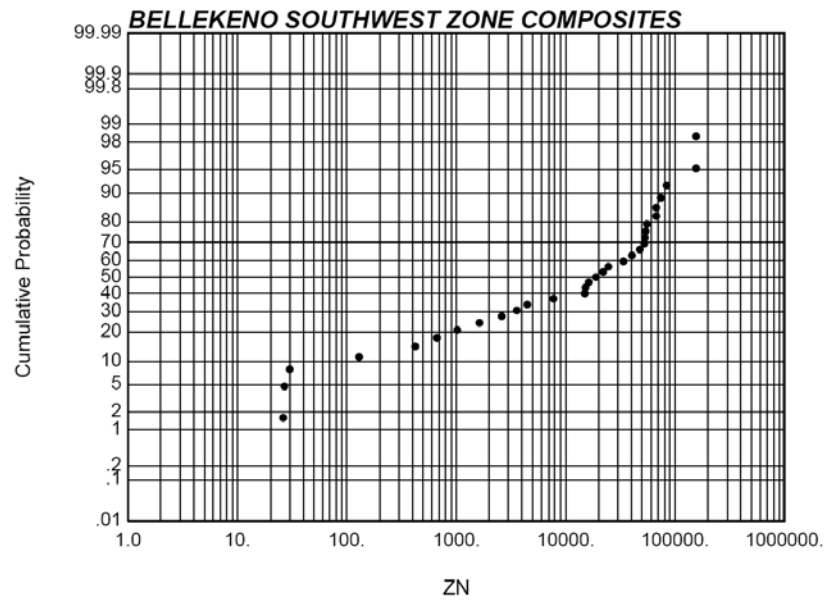

Cumulative frequency plot for gold composites (East Zone).

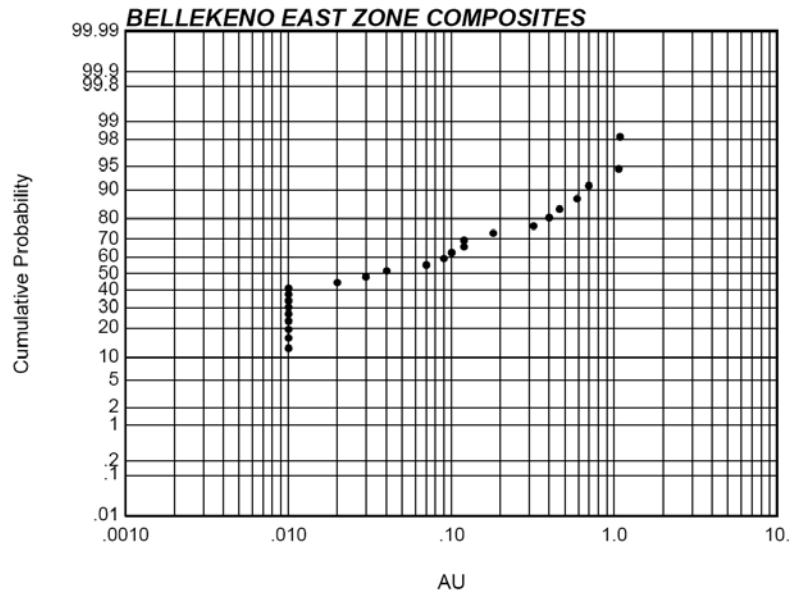

Cumulative frequency plot for Zinc composites (East Zone).

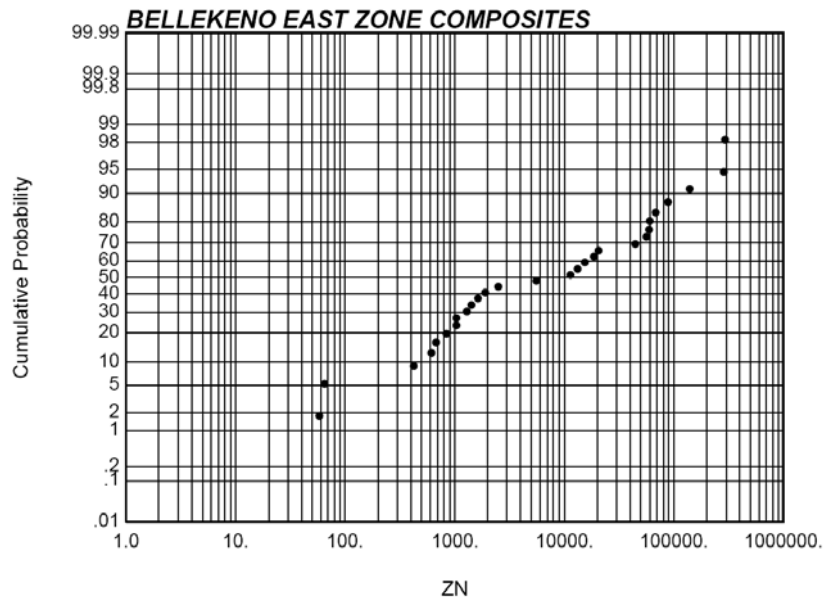

Lead variogram, strike direction.

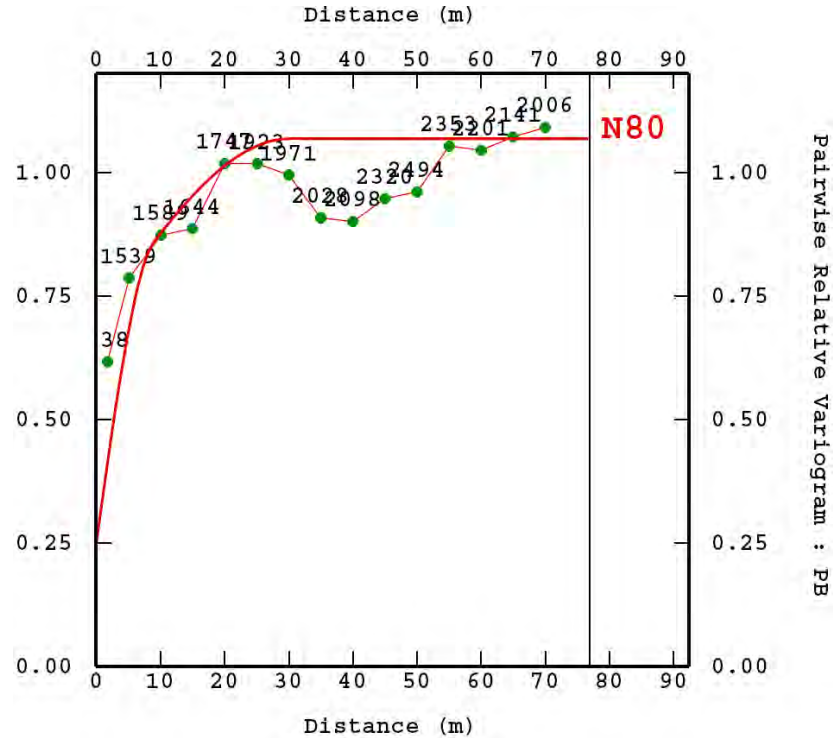

Lead variogram, dip direction.

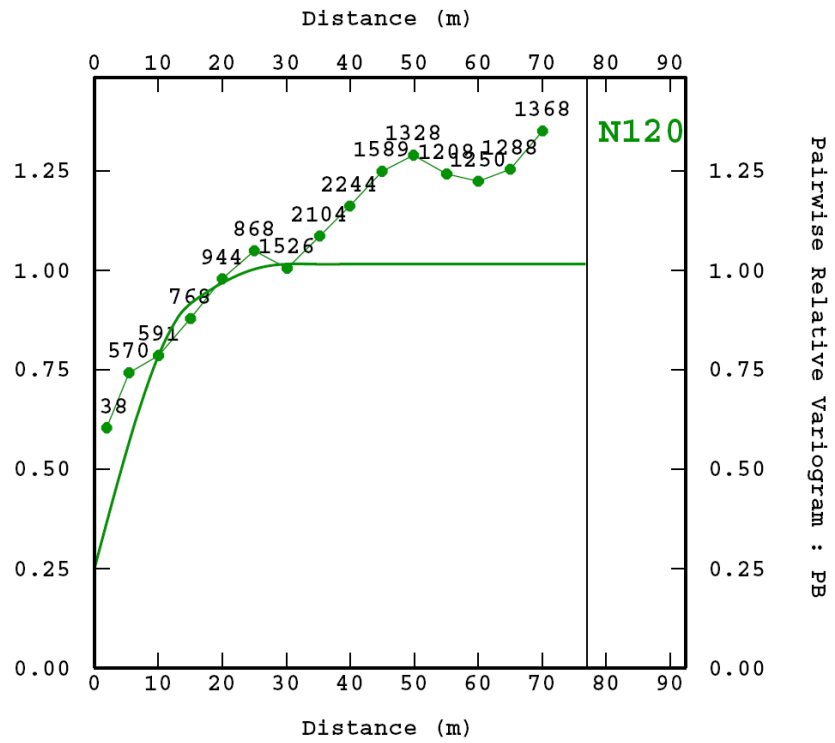

Zinc variogram, strike direction.

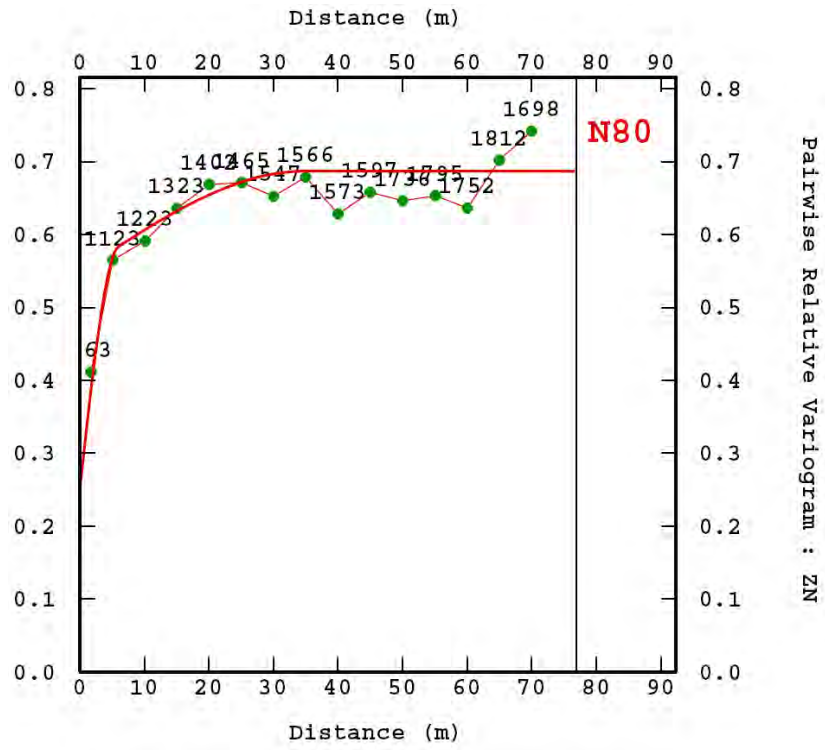

Zinc variogram, dip direction.

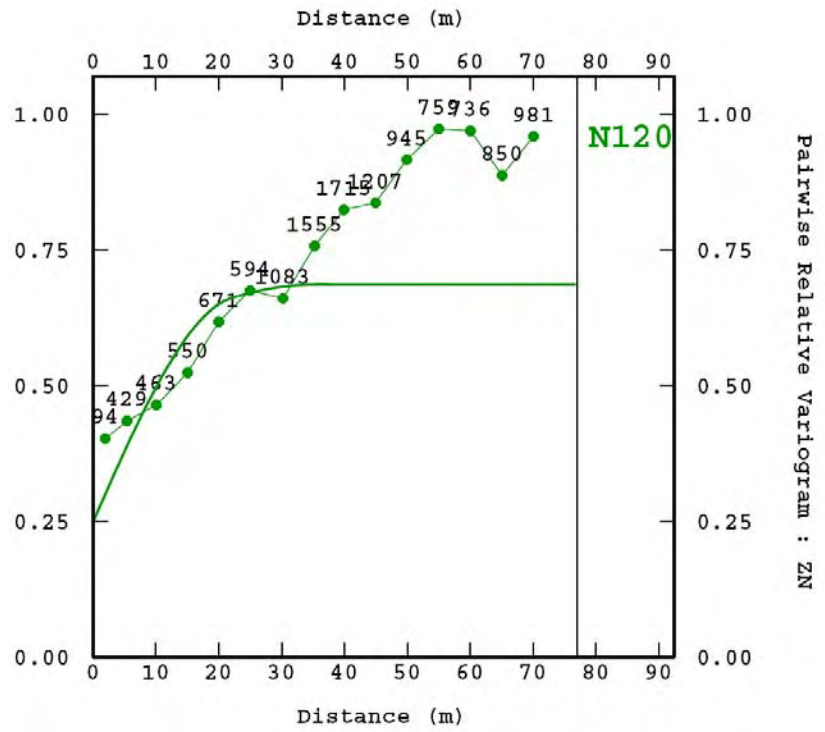

Silver check variogram, strike direction.

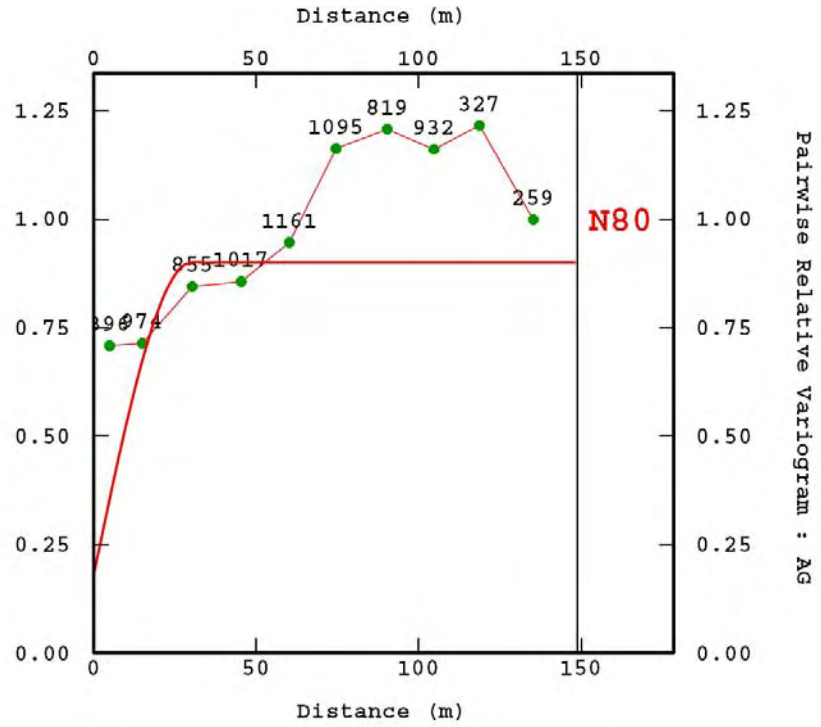

Silver check variogram, dip direction.

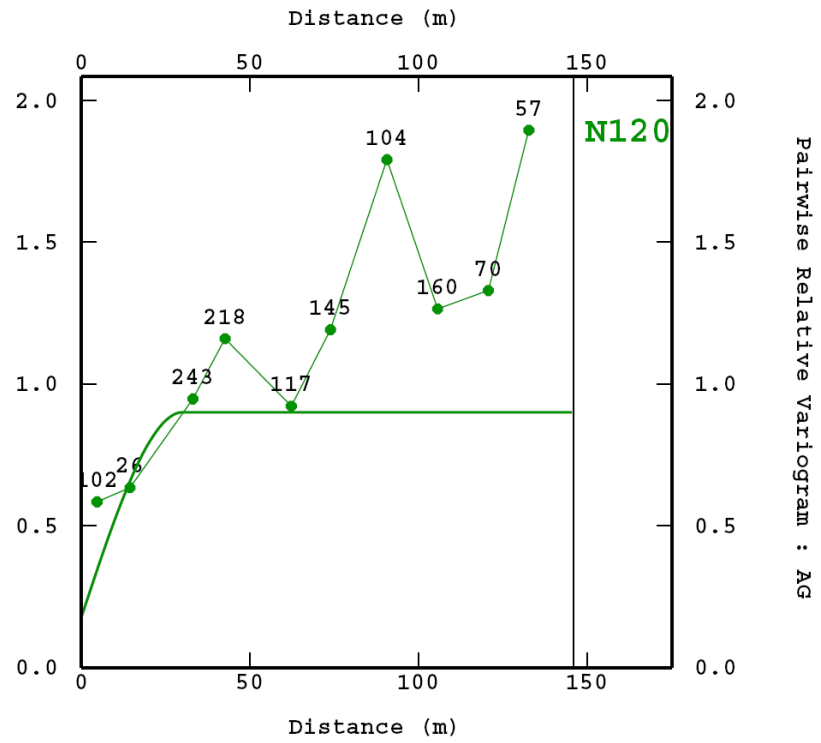

Lead check variogram, strike direction.

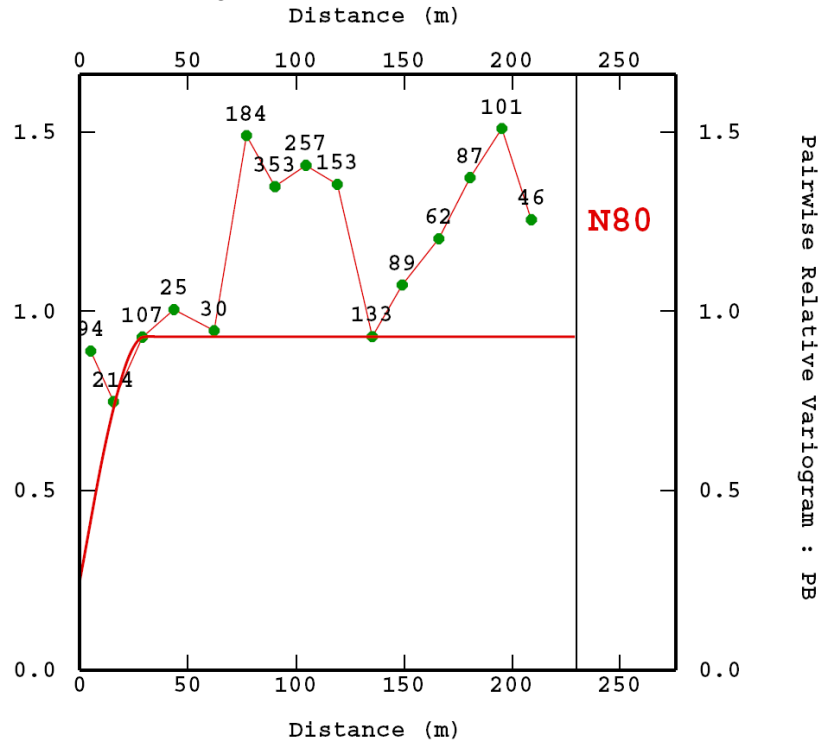

Lead check variogram, dip direction.

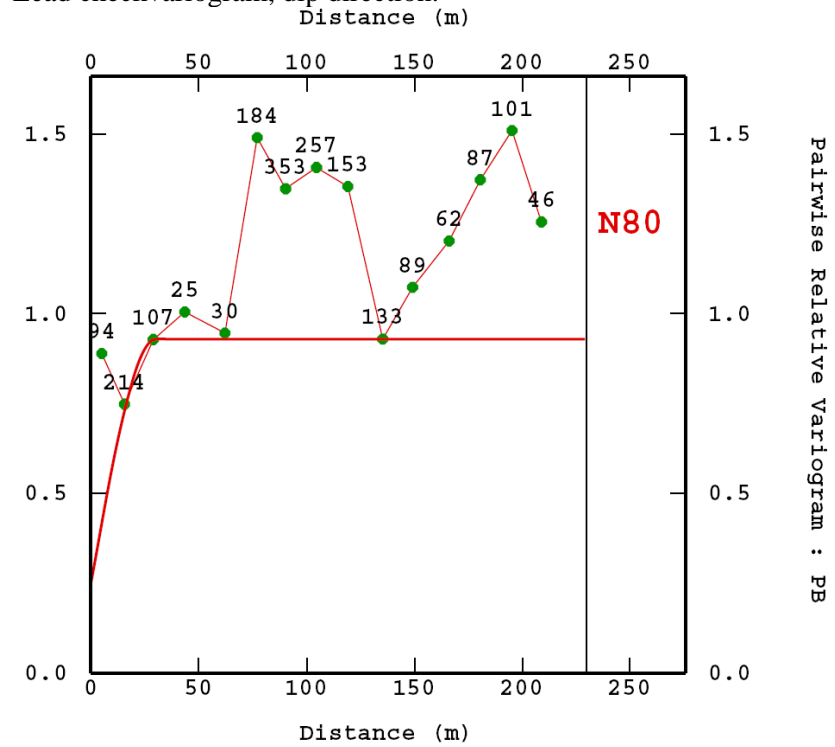

Zinc check variogram, strike direction.

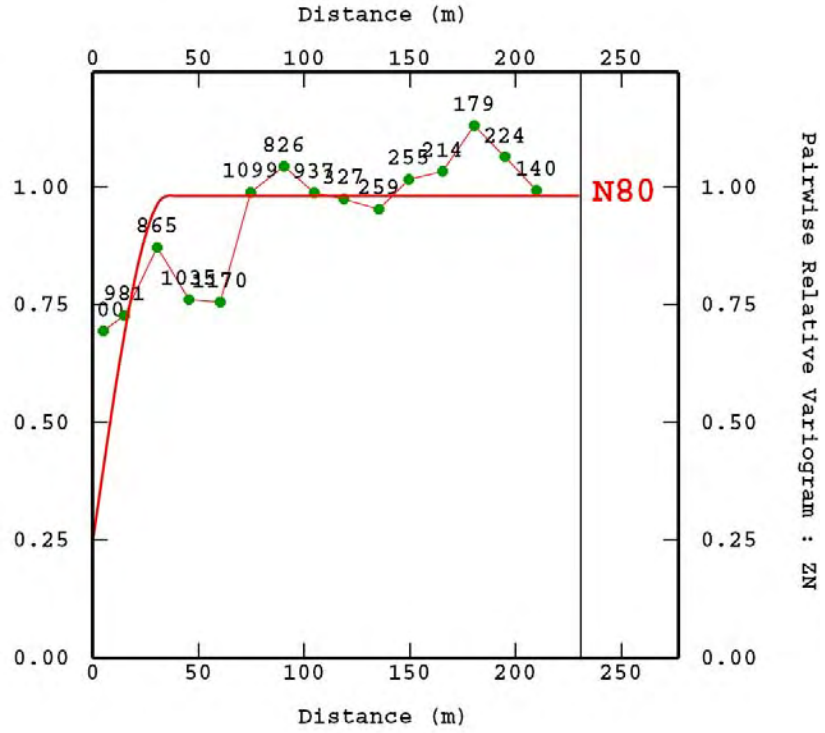

Zinc checkvariogram, dip direction.

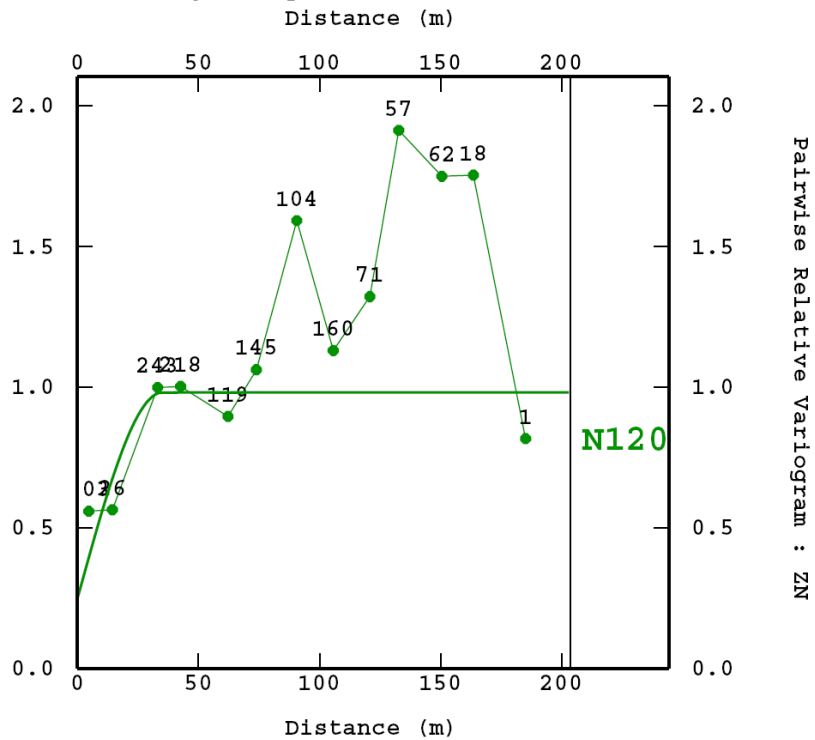

APPENDIX C

Underground Geotechnical Information

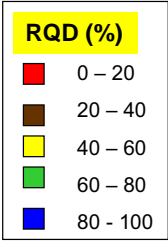
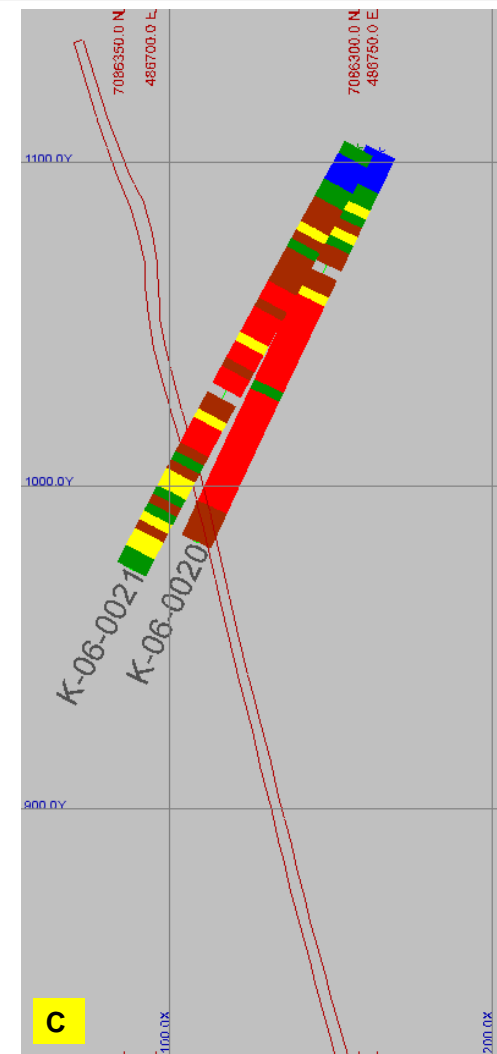
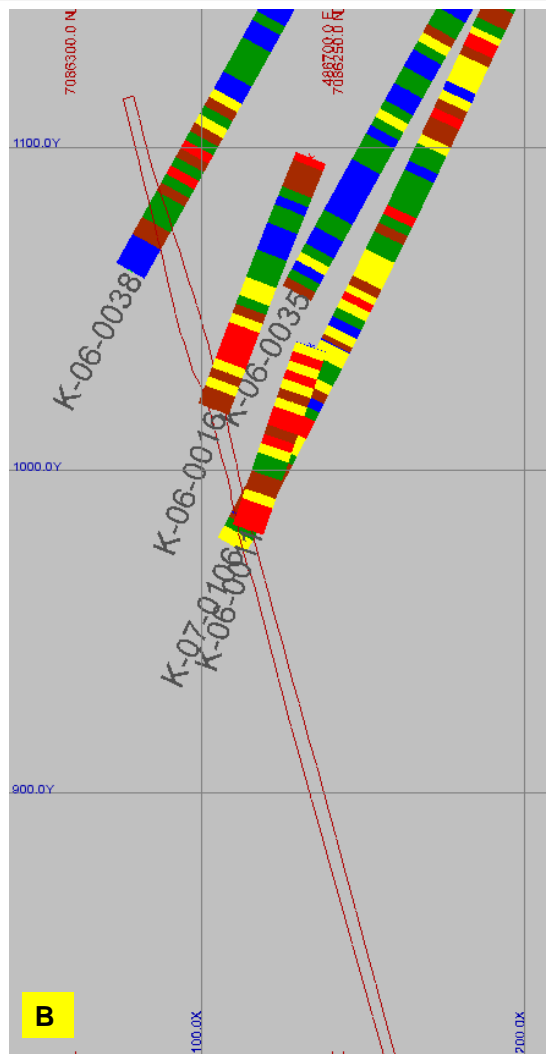
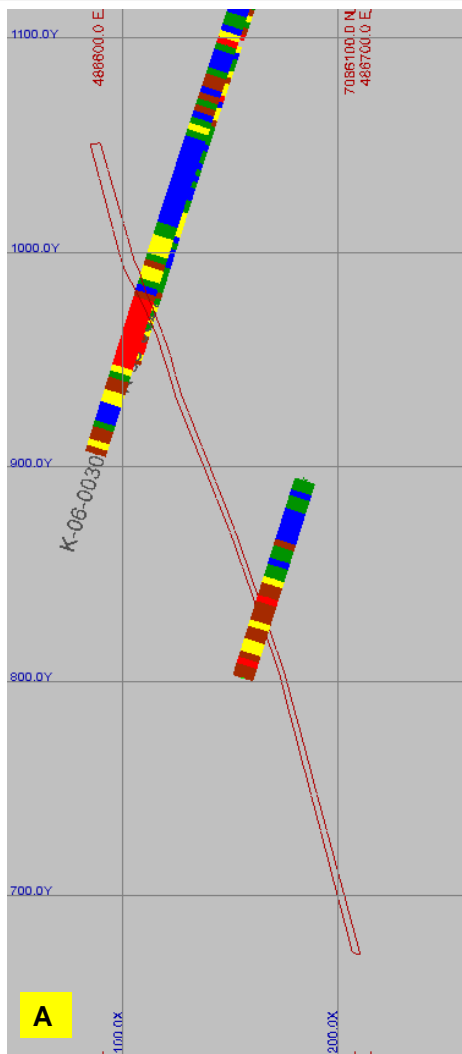

Notes:

1. Vertical section looking north through orebody.
2. True mineralization thickness at drillhole puncture point in meters.
3. Grid lines at 100m spacing.



Bellekeno Project
Geotechnical Evaluation

**Geotechnical Assessment of
Southwest Zone: RQD Sections**

PROJECT: 2CA017.000	DATE: June 2008	APPROVED:	FIGURE: C2
------------------------	--------------------	-----------	---------------



368.4 – 384.7m



384.7 – 402.3m

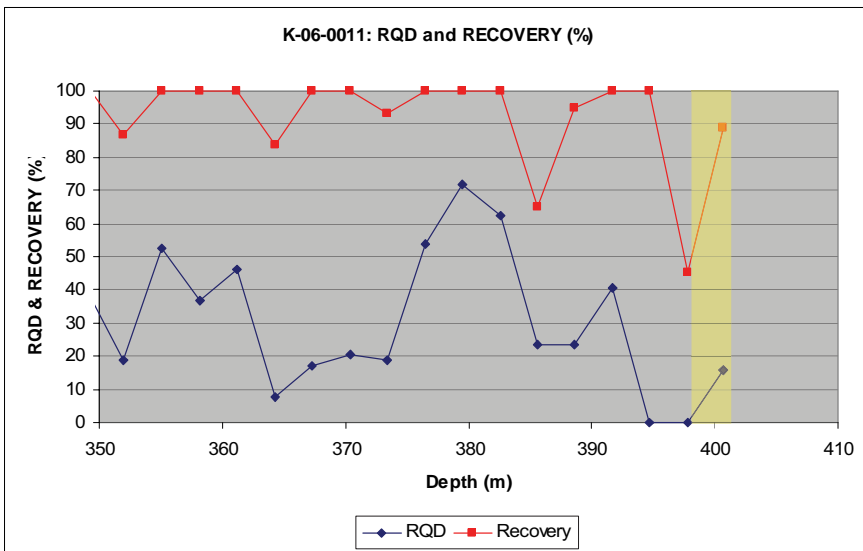

- Notes:**
- Orebody intercept length is apparent only.
 - Orebody intercept inferred from modeled solids.

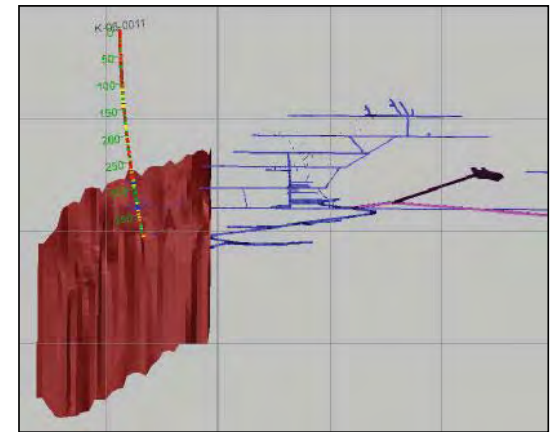

		Bellekeno Project Geotechnical Evaluation			
		Geotechnical Assessment Southwest Zone: K-06-0011			
PROJECT: 2CA017.000	DATE: June 2008	APPROVED:	FIGURE:	C1	



339.45 – 355.0m



355.0 – 371.9m

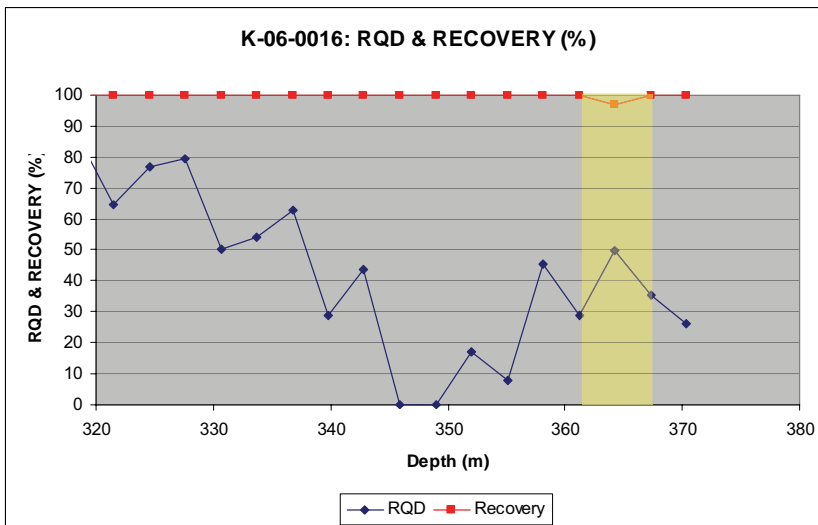

- Notes:**
- Orebody intercept length is apparent only.
 - Orebody intercept inferred from modeled solids.

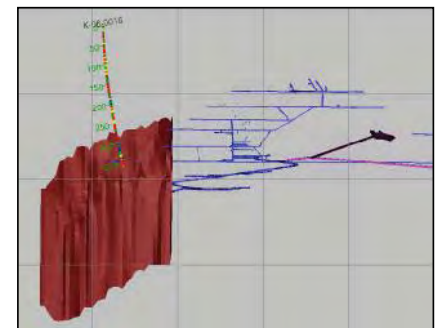

SRK Consulting
Engineers and Scientists



Bellekeno Project
Geotechnical Evaluation

**Geotechnical Assessment Southwest
Zone: K-06-0016**

PROJECT: 2CA017.000	DATE: June 2008	APPROVED:	FIGURE: C1
------------------------	--------------------	-----------	---------------



385.40 – 402.4m



402.4 – 417.6m

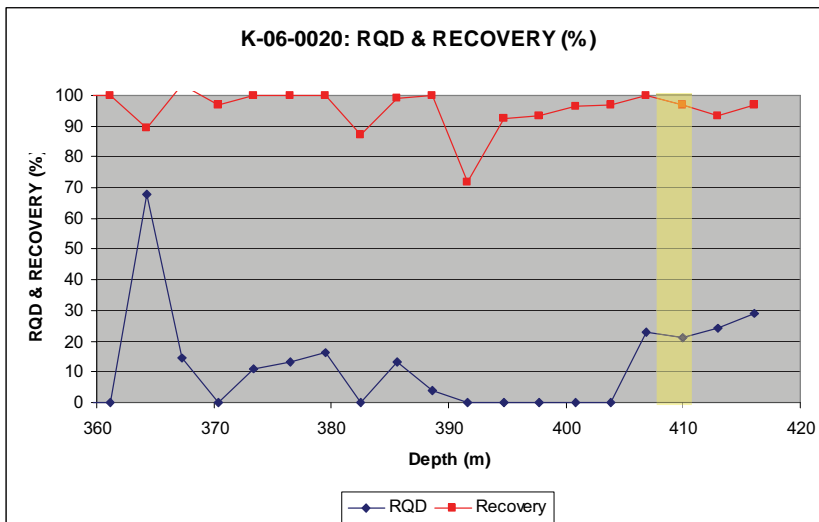

- Notes:**
- Orebody intercept length is apparent only.
 - Orebody intercept inferred from modeled solids.

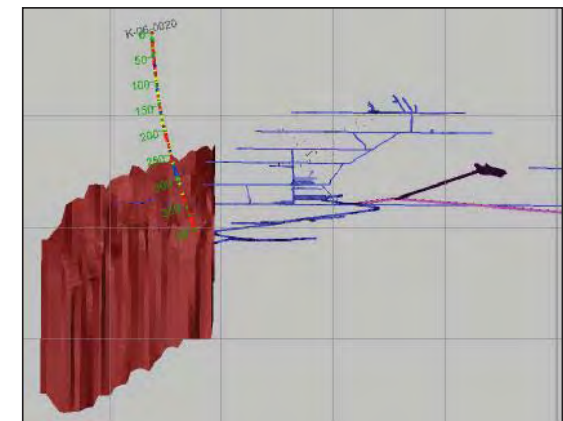

SRK Consulting <small>Engineers and Scientists</small>		Bellekeno Project Geotechnical Evaluation	
Geotechnical Assessment Southwest Zone: K-06-0020			
PROJECT: 2CA017.000	DATE: June 2008	APPROVED:	FIGURE: C1



372.9-389.0m



389.0-405.2m

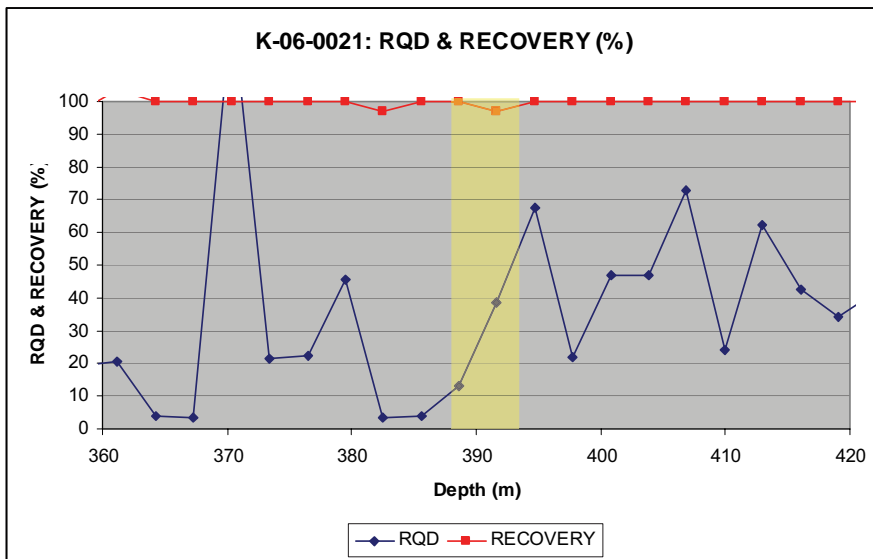

- Notes:**
- Orebody intercept length is apparent only.
 - Orebody intercept inferred from modeled solids.

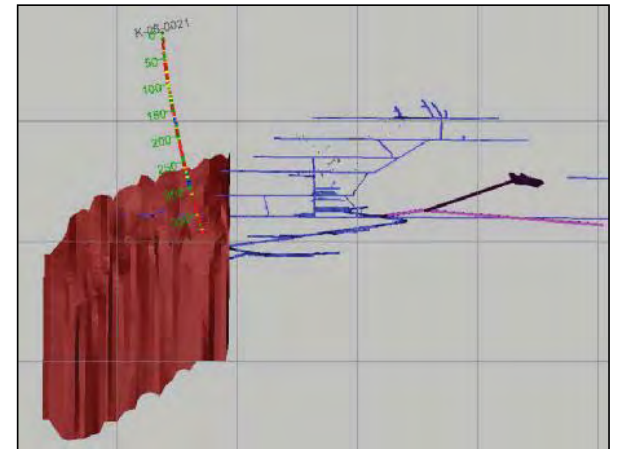

Bellekeno Project Geotechnical Evaluation			
Geotechnical Assessment Southwest Zone: K-06-0021			
PROJECT: 2CA017.000	DATE: June 2008	APPROVED:	FIGURE: C1



426.0-442.0m



442.0-453.2m

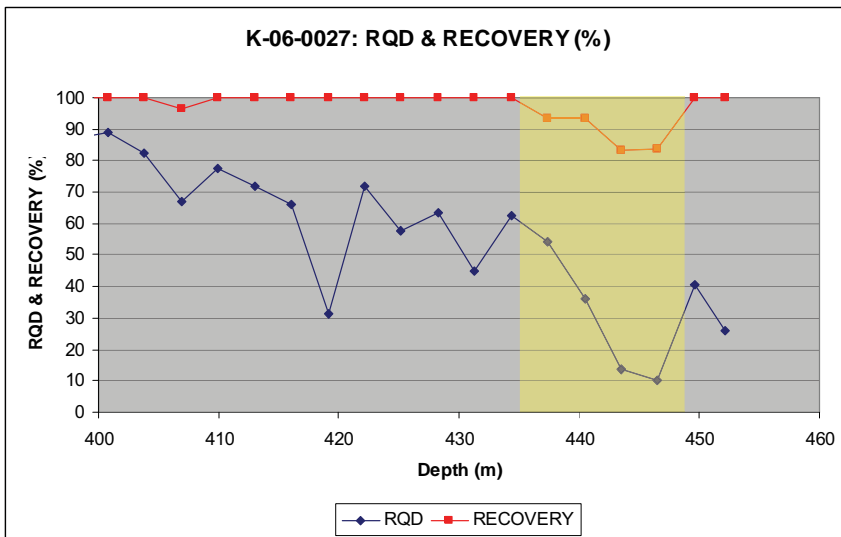

- Notes:
- Orebody intercept length is apparent only.
 - Orebody intercept inferred from modeled solids.

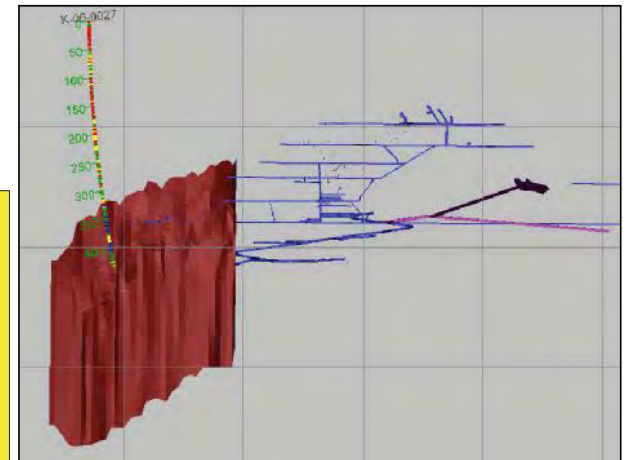

Bellekeno Project Geotechnical Evaluation			
Geotechnical Assessment Southwest Zone: K-06-0027			
PROJECT: 2CA017.000	DATE: June 2008	APPROVED:	FIGURE: C1



394.09-410.48m



410.48-426.6m



426.6-441.1m

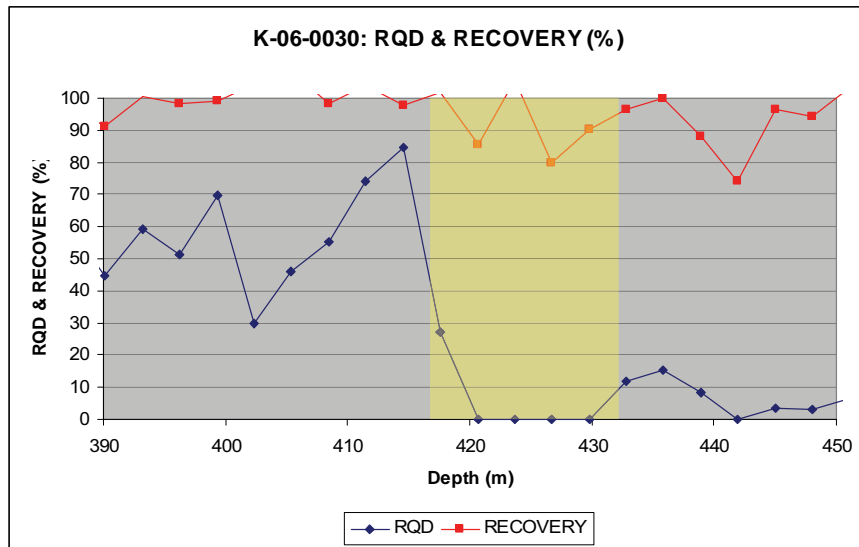

- Notes:
- Orebody intercept length is apparent only.
 - Orebody intercept inferred from modeled solids.

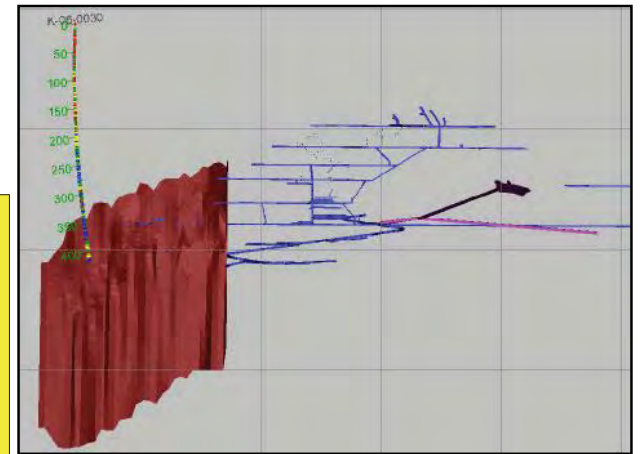

Bellekeno Project Geotechnical Evaluation			
Geotechnical Assessment Southwest Zone: K-06-0030			
PROJECT: 2CA017.000	DATE: June 2008	APPROVED:	FIGURE: C1



382.25-402.71m



402.71-422.52m



422.52-438.00m

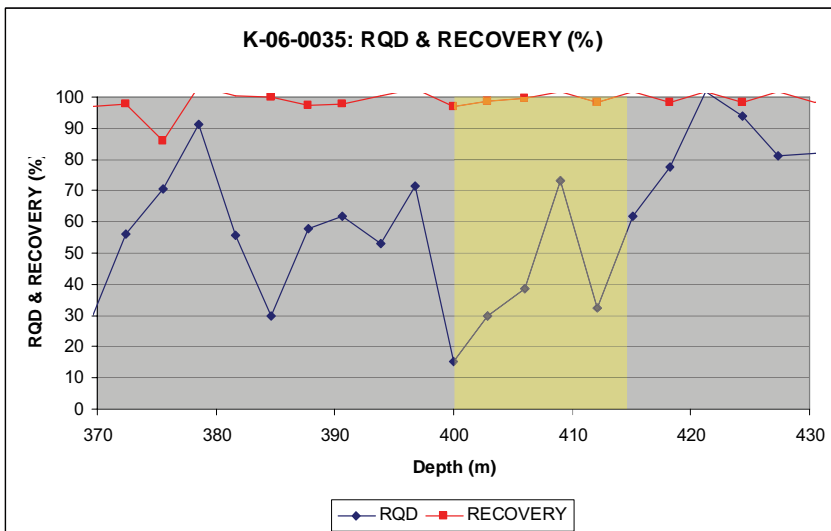

- Notes:
- Orebody intercept length is apparent only.
 - Orebody intercept inferred from modeled solids.

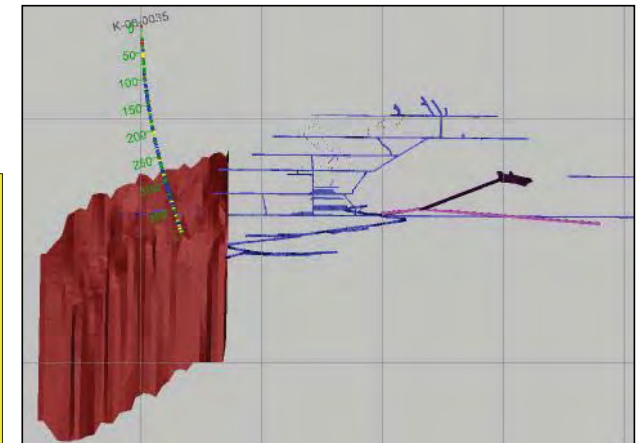

Bellekeno Project Geotechnical Evaluation			
Geotechnical Assessment Southwest Zone: K-06-0035			
PROJECT: 2CA017.000	DATE: June 2008	APPROVED:	FIGURE: C1



293.64-309.55m



309.55-326.44

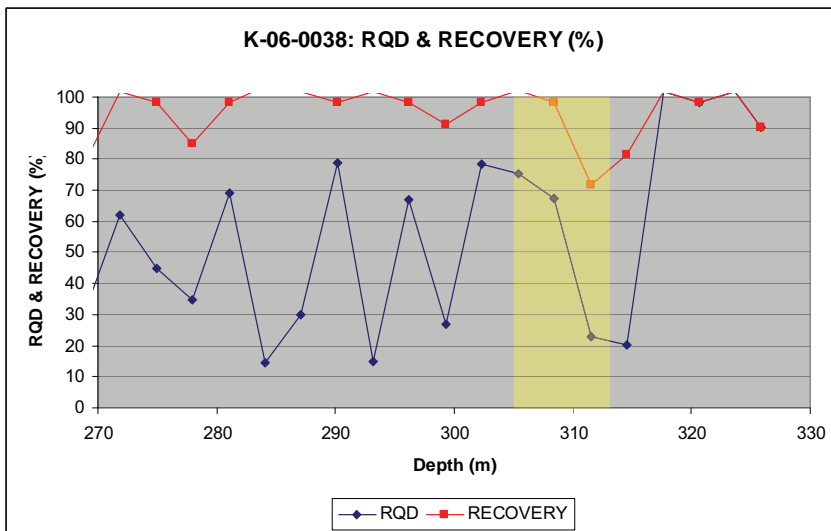

- Notes:
- Orebody intercept length is apparent only.
 - Orebody intercept inferred from modeled solids.

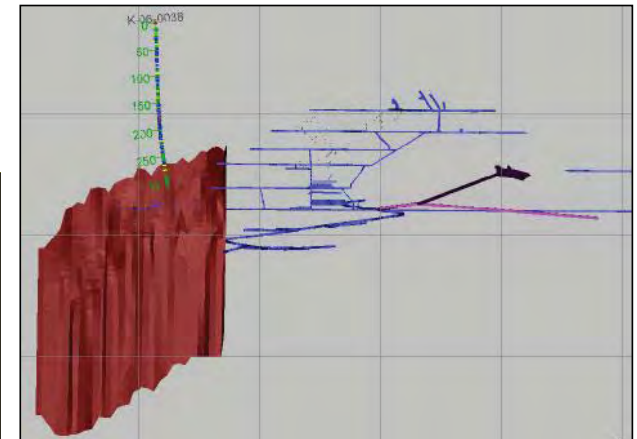

Bellekeno Project Geotechnical Evaluation			
Geotechnical Assessment Southwest Zone: K-06-0038			
PROJECT: 2CA017.000	DATE: June 2008	APPROVED:	FIGURE: C1



375.25-379.74m



379.74-383.63m



383.63-389.84m

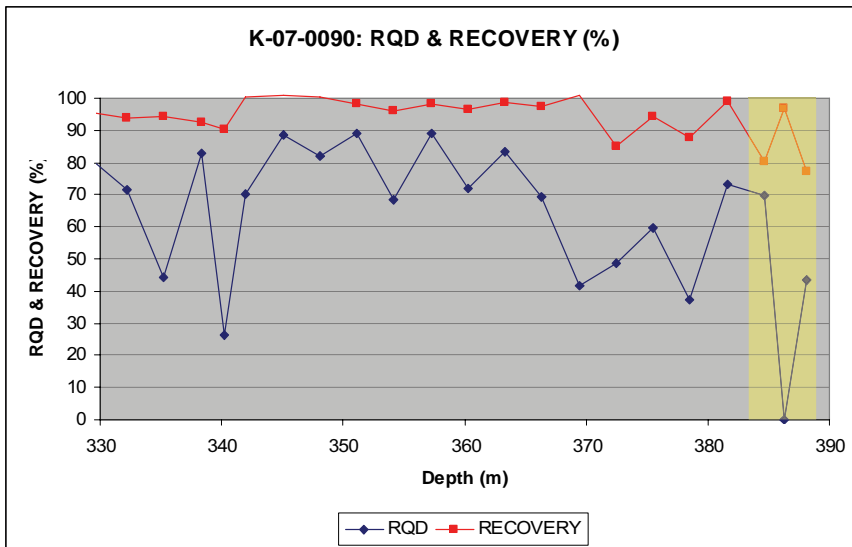

- Notes:**
- Orebody intercept length is apparent only.
 - Orebody intercept inferred from modeled solids.

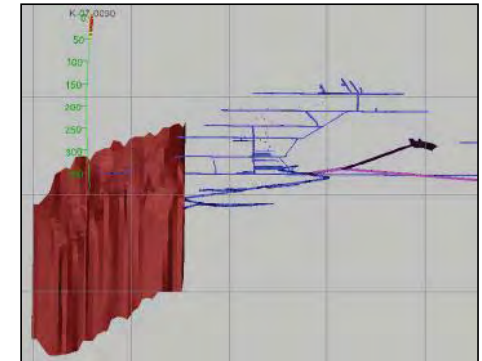

Bellekeno Project Geotechnical Evaluation			
Geotechnical Assessment Southwest Zone: K-07-0090			
PROJECT: 2CA017.000	DATE: June 2008	APPROVED:	FIGURE: C1



515.23-519.25m



519.25-522.41m

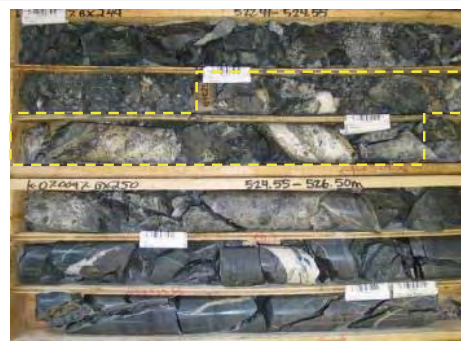

522.41-526.50m



526.50-530.36m

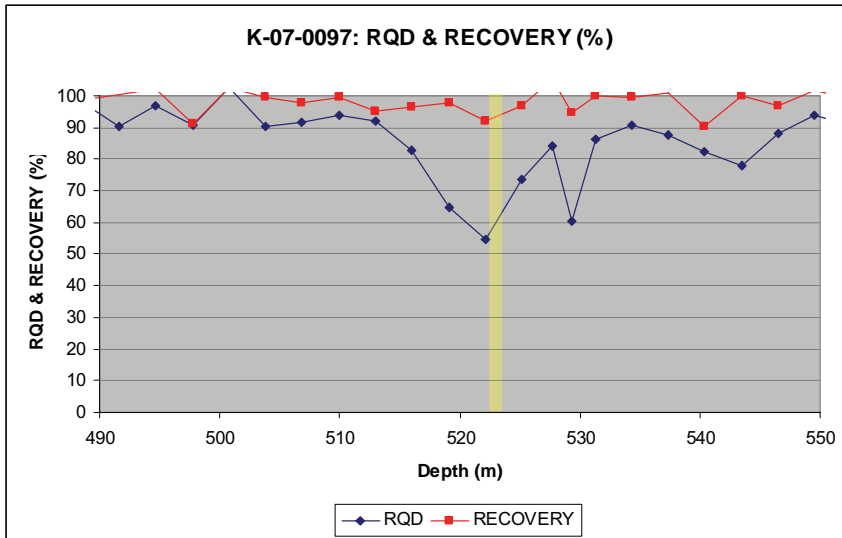

- Notes:**
- Orebody intercept length is apparent only.
 - Orebody intercept inferred from modeled solids.

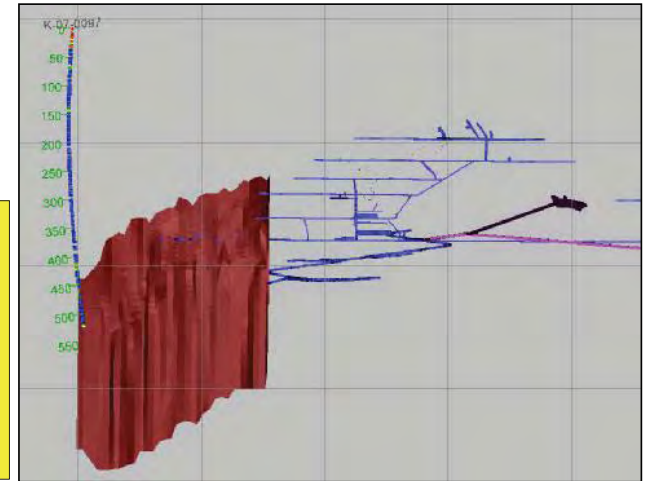

SRK Consulting <small>Engineers and Scientists</small>		Bellekeno Project Geotechnical Evaluation	
Geotechnical Assessment Southwest Zone: K-07-0097			
PROJECT:	DATE:	APPROVED:	FIGURE:
2CA017.000	June 2008	[Signature]	C1



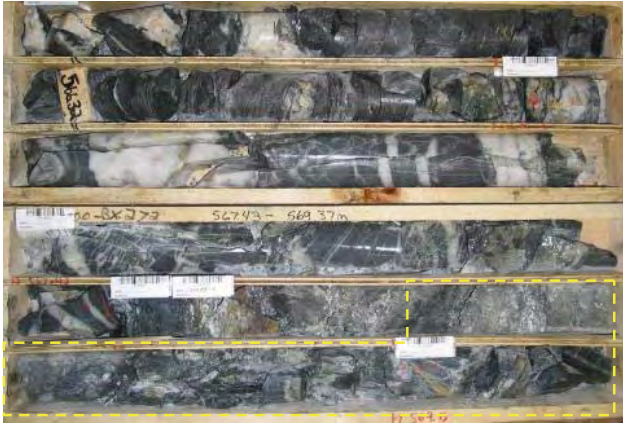

565.64-569.37m

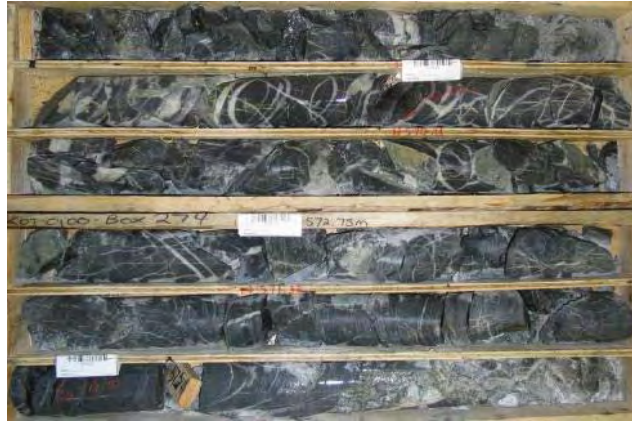

569.37-572.75



572.75-576.73m

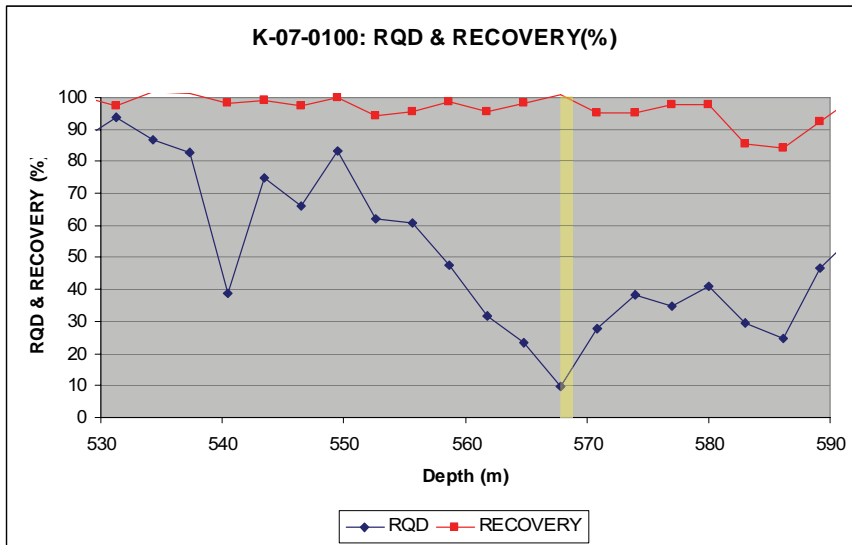

- Notes:**
- Orebody intercept length is apparent only.
 - Orebody intercept inferred from modeled solids.

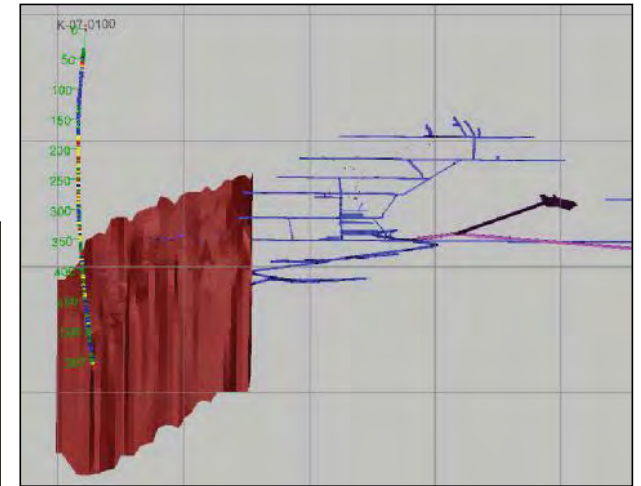

SRK Consulting <small>Engineers and Scientists</small>		Bellekeno Project Geotechnical Evaluation	
		Geotechnical Assessment Southwest Zone: K-07-0100	
PROJECT:	DATE:	APPROVED:	FIGURE:
2CA017.000	June 2008		C1

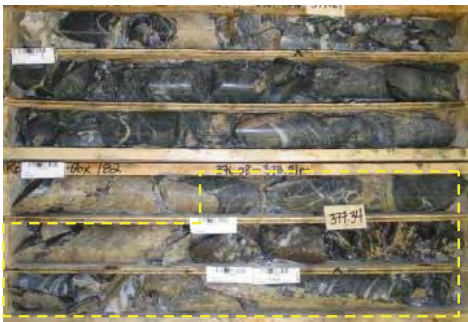

374.01-378.21m



378.21-382.58m



382.58-389.16m

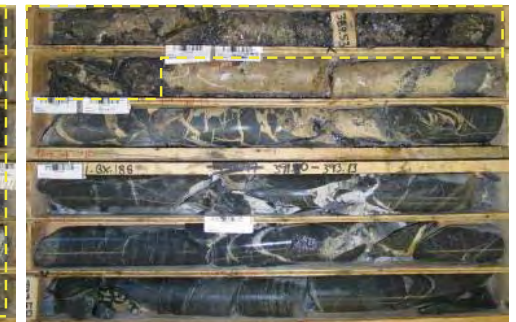

389.16-393.13m

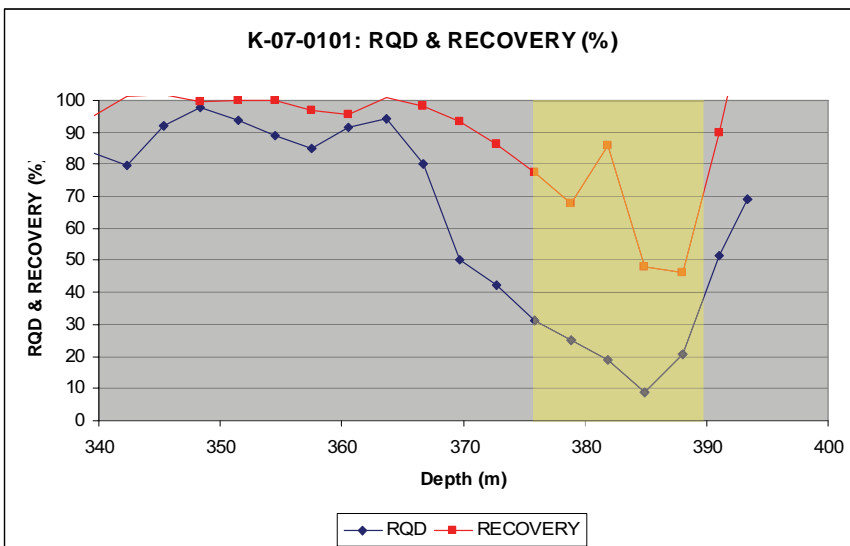

- Notes:
- Orebody intercept length is apparent only.
 - Orebody intercept inferred from modeled solids.

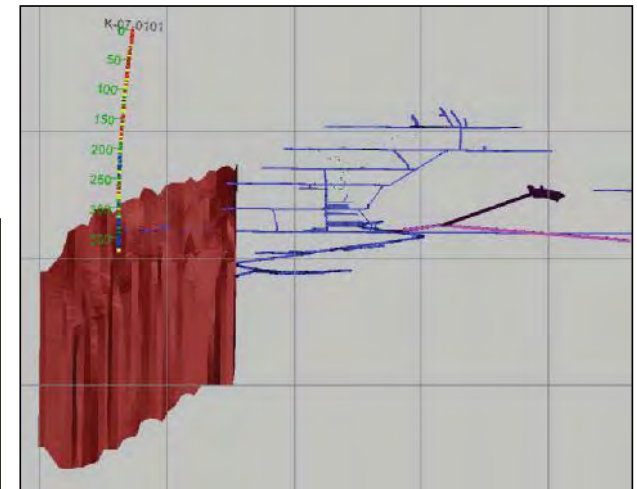

Bellekeno Project Geotechnical Evaluation			
Geotechnical Assessment Southwest Zone: K-07-0101			
PROJECT: 2CA017.000	DATE: June 2008	APPROVED:	FIGURE: C1



391.68-395.63m



395.63-399.69m



399.69-402.97m



402.9-404.77

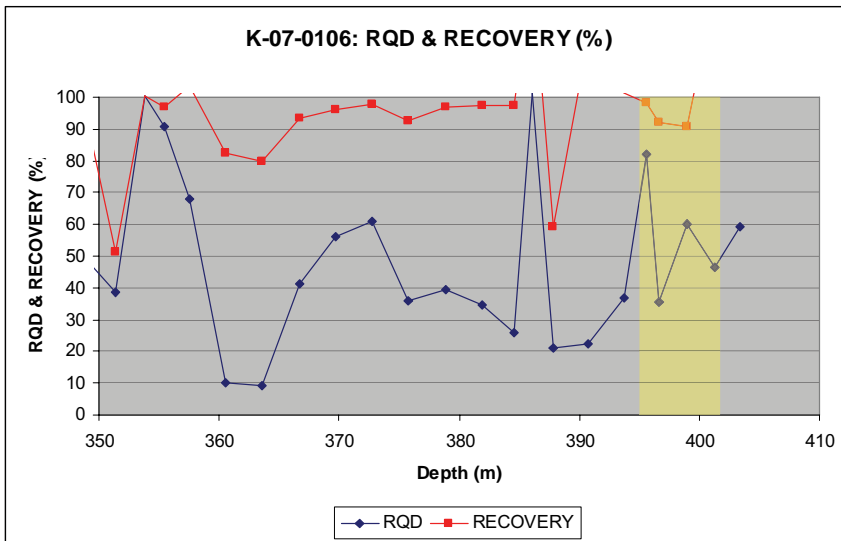

- Notes:**
- Orebody intercept length is apparent only.
 - Orebody intercept inferred from modeled solids.



Bellekeno Project Geotechnical Evaluation			
Geotechnical Assessment Southwest Zone: K-07-0106			
PROJECT: 2CA017.000	DATE: June 2008	APPROVED:	FIGURE: C1

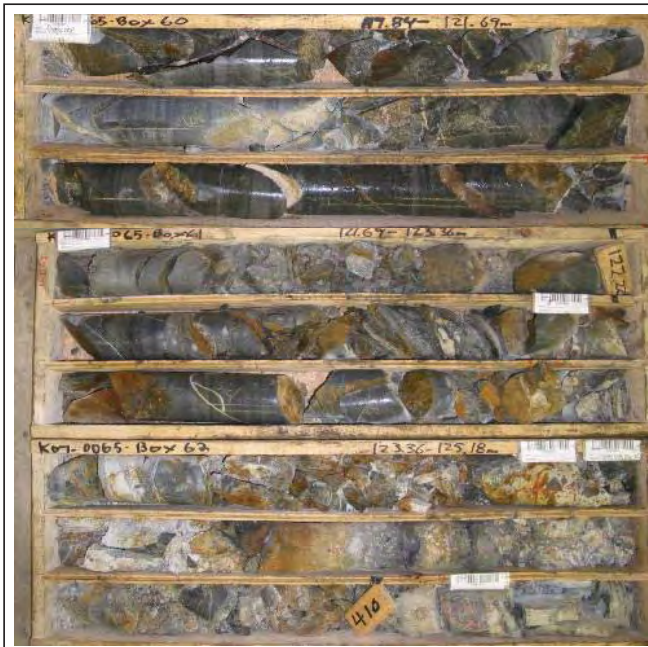

119.84 – 125.18m



125.18 – 129.47m



129.47 – 135.29m

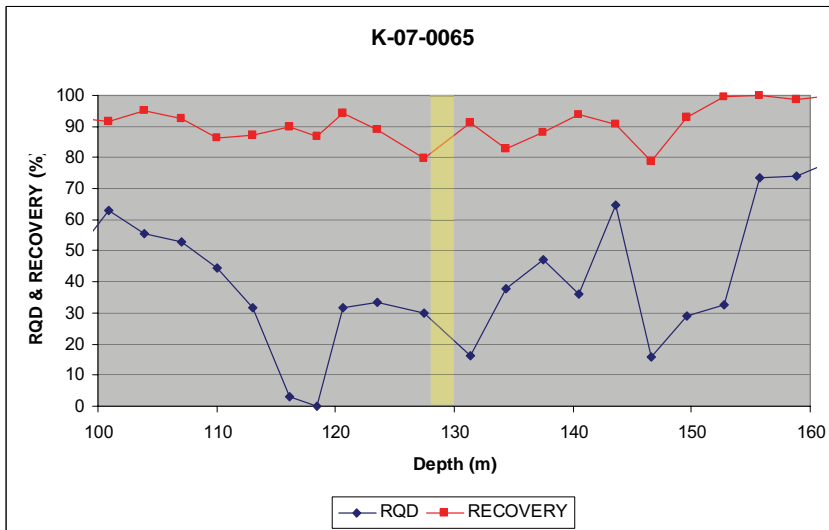

Notes:

- Orebody intercept length is apparent only.
- Orebody intercept inferred from modeled solids.

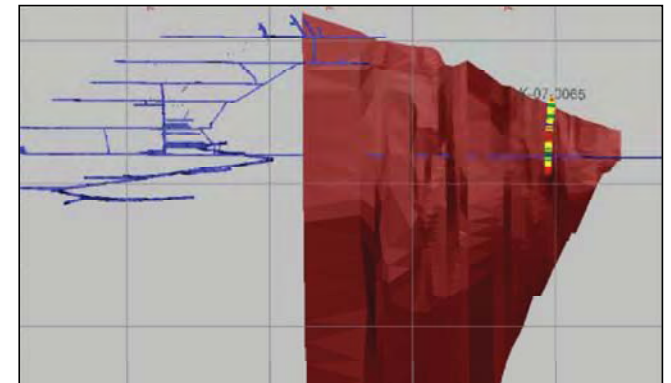

		Bellekeno Project Geotechnical Evaluation		
		Geotechnical Assessment of East Zone: K-07-0065		
PROJECT: 2CA017.000	DATE: June 2008	APPROVED:	FIGURE: C1	



164.94 – 169.67m



169.67 – 173.57m



173.57 – 179.15m

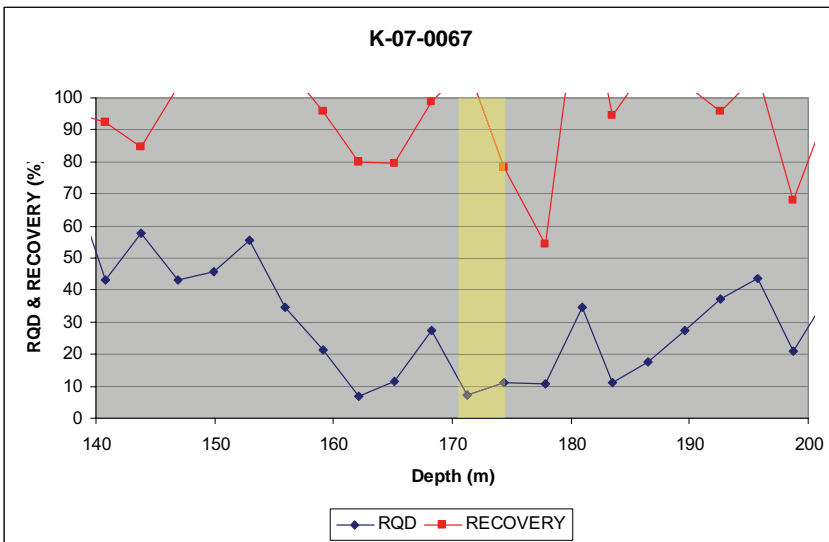

- Notes:
- Orebody intercept length is apparent only.
 - Orebody intercept inferred from modeled solids.

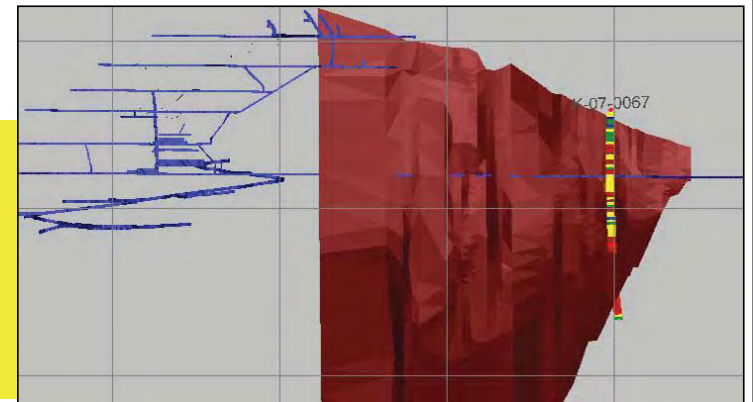

Bellekeno Project Geotechnical Evaluation			
Geotechnical Assessment of East Zone: K-07-0067			
PROJECT: 2CA017.000	DATE: June 2008	APPROVED:	FIGURE: C1

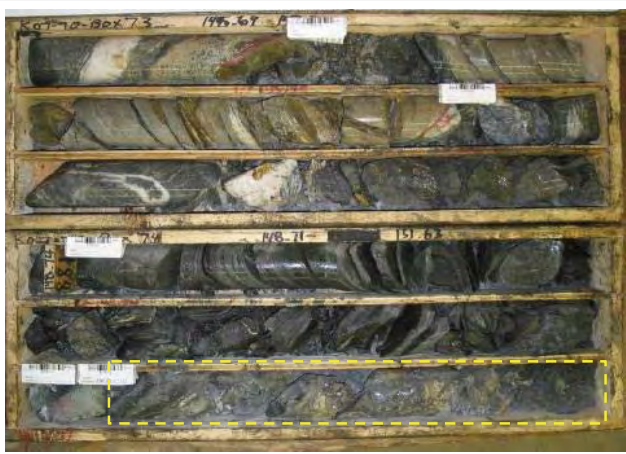

145.69 – 151.63m

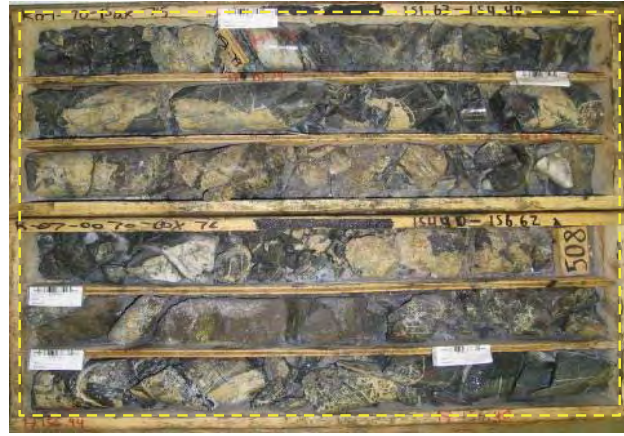

151.63 – 156.62m



156.62 – 160.67m

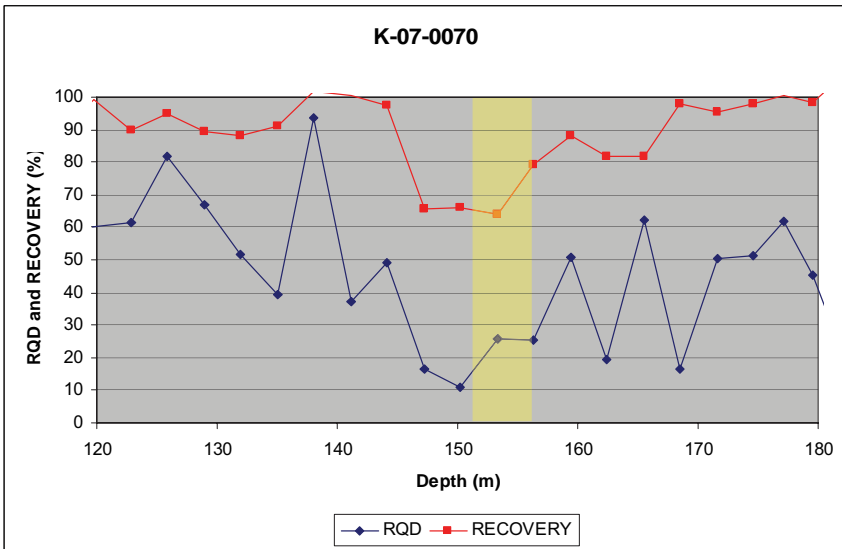

Notes:

- Orebody intercept length is apparent only.
- Orebody intercept inferred from modeled solids.

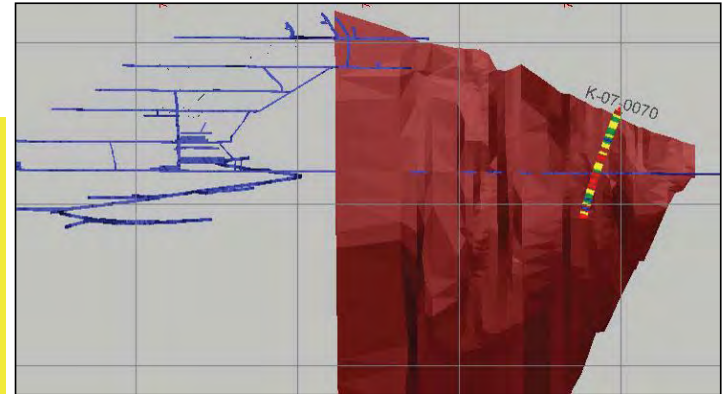

Bellekeno Project
Geotechnical Evaluation

Geotechnical Assessment of East Zone: K-07-0070

PROJECT: 2CA017.000	DATE: June 2008	APPROVED:	FIGURE: C1
------------------------	--------------------	-----------	---------------

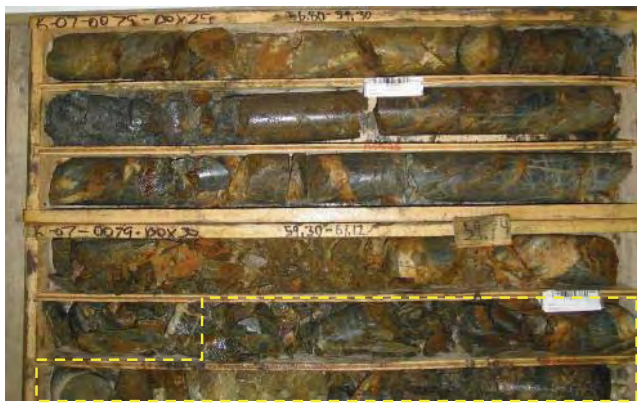

56.8 – 61.12m



61.12 – 64.65m



64.65 – 68.57m

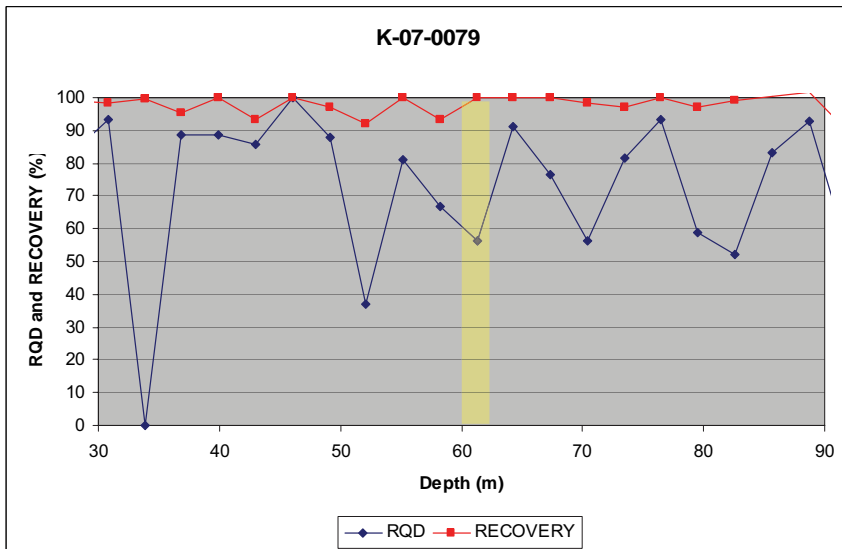

- Notes:
- Orebody intercept length is apparent only.
 - Orebody intercept inferred from modeled solids.

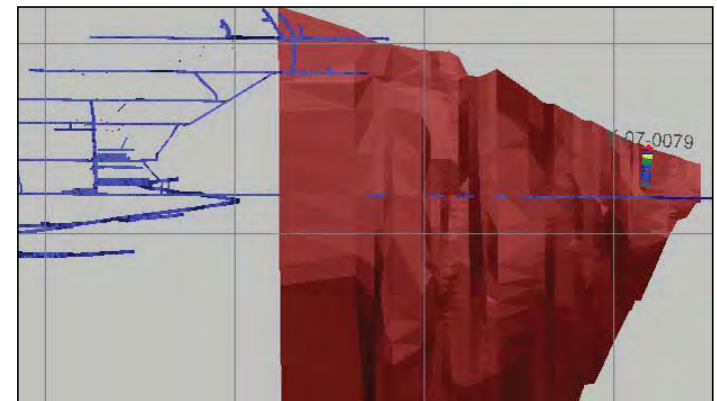

Bellekeno Project Geotechnical Evaluation			
Geotechnical Assessment of East Zone: K-07-0079			
PROJECT: 2CA017.000	DATE: June 2008	APPROVED:	FIGURE: C1



185.36 – 189.58m



189.58 – 194.35m



194.35 – 199.32m

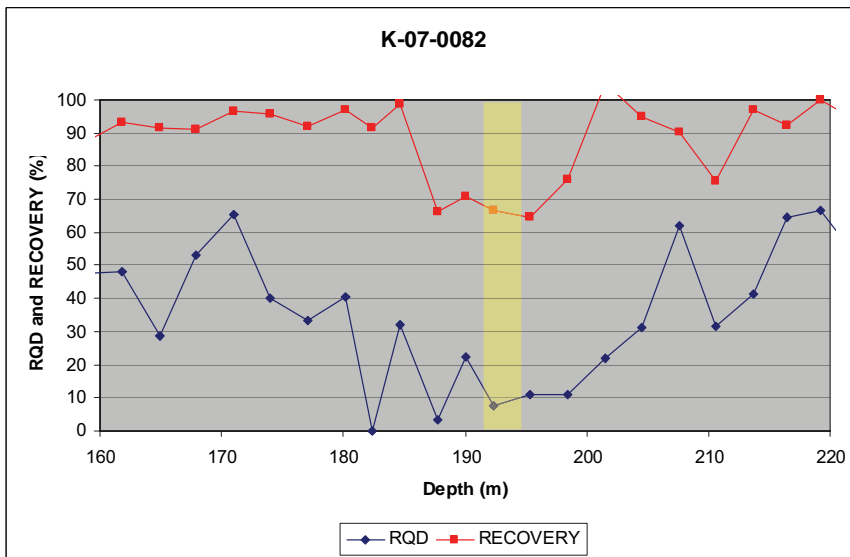

Notes:

1. Orebody intercept length is apparent only.
2. Orebody intercept inferred from modeled solids.

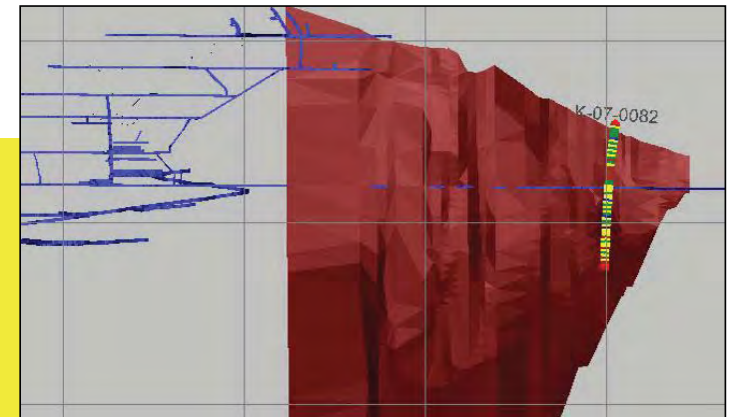

Bellekeno Project
Geotechnical Evaluation

**Geotechnical Assessment of East
Zone: K-07-0082**

PROJECT: 2CA017.000	DATE: June 2008	APPROVED:	FIGURE: C1
------------------------	--------------------	-----------	---------------



221.04 – 225.45m

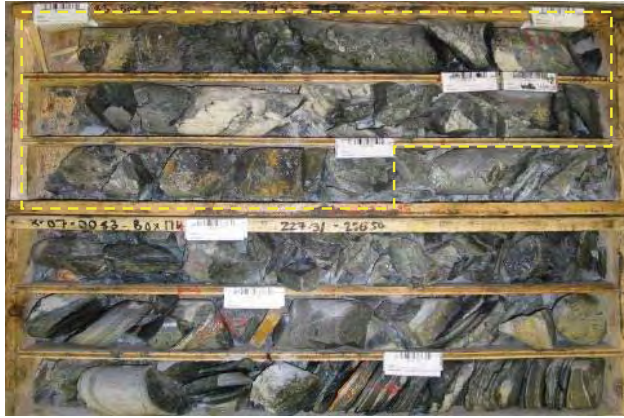

225.45 – 228.50m



228.50 – 232.47m

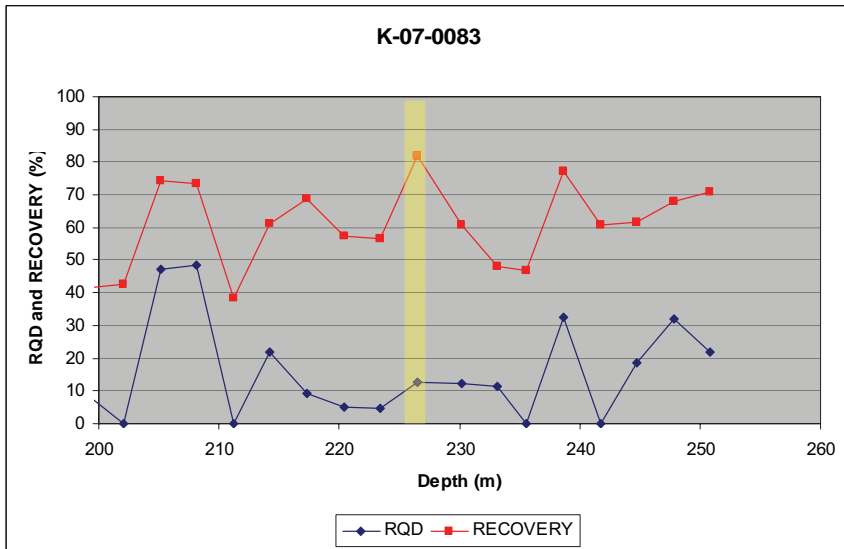

Notes:

1. Orebody intercept length is apparent only.
2. Orebody intercept inferred from modeled solids.

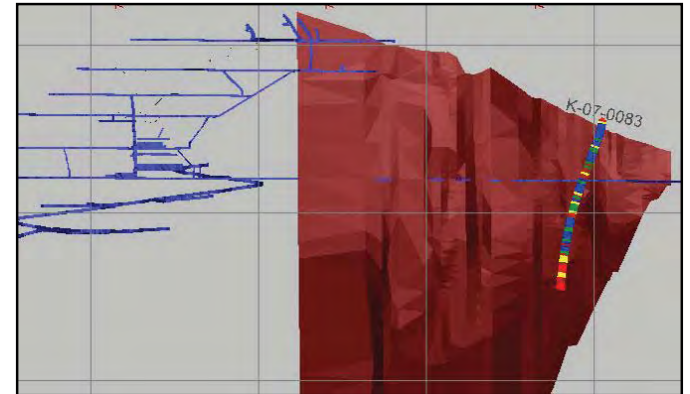

Bellekeno Project
Geotechnical Evaluation

**Geotechnical Assessment of East
Zone: K-07-0083**

PROJECT: 2CA017.000	DATE: June 2008	APPROVED:	FIGURE: C1
------------------------	--------------------	-----------	---------------



219.37 – 223.17m



223.17 – 227.53m



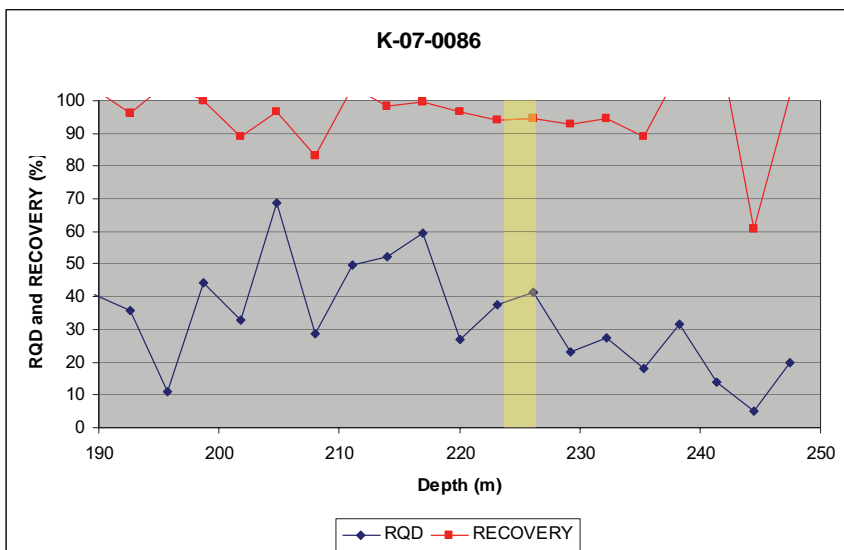

227.53 – 231.04m

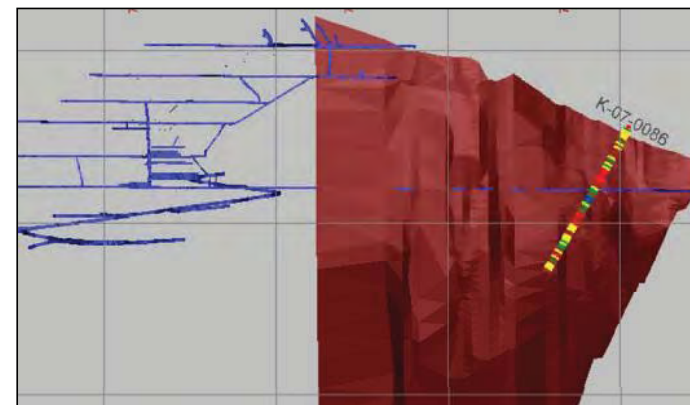

Notes:

- Orebody intercept length is apparent only.
- Orebody intercept inferred from modeled solids.



 SRK Consulting <i>Engineers and Scientists</i>		Bellekeno Project Geotechnical Evaluation	
		Geotechnical Assessment of East Zone: K-07-0086	
PROJECT: 2CA017.000	DATE: June 2008	APPROVED:	FIGURE: C1



325.80 – 329.43m



329.43 – 333.43m



333.43 – 337.72m

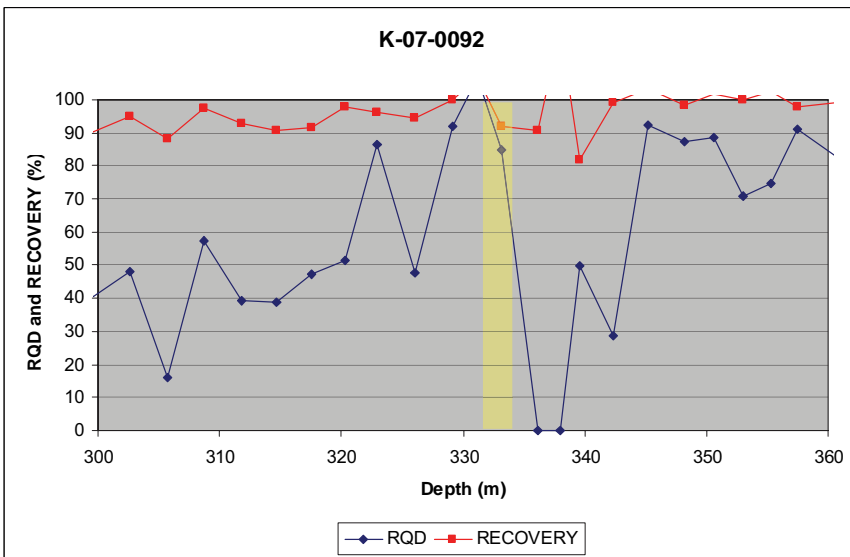

Notes:

- Orebody intercept length is apparent only.
- Orebody intercept inferred from modeled solids.

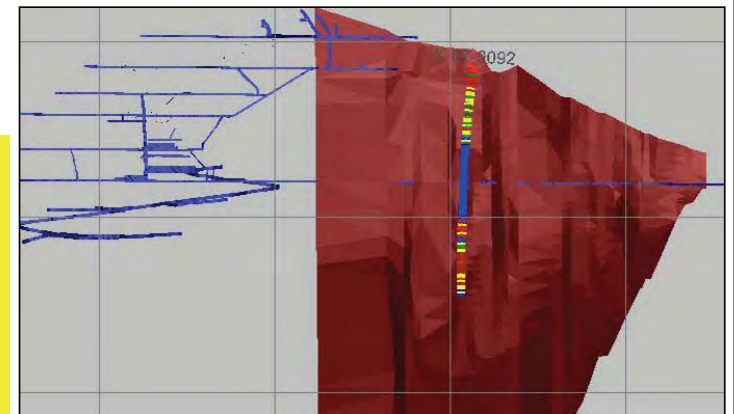



388.34 – 394.21m



394.21 – 398.16m



398.16 – 401.82m

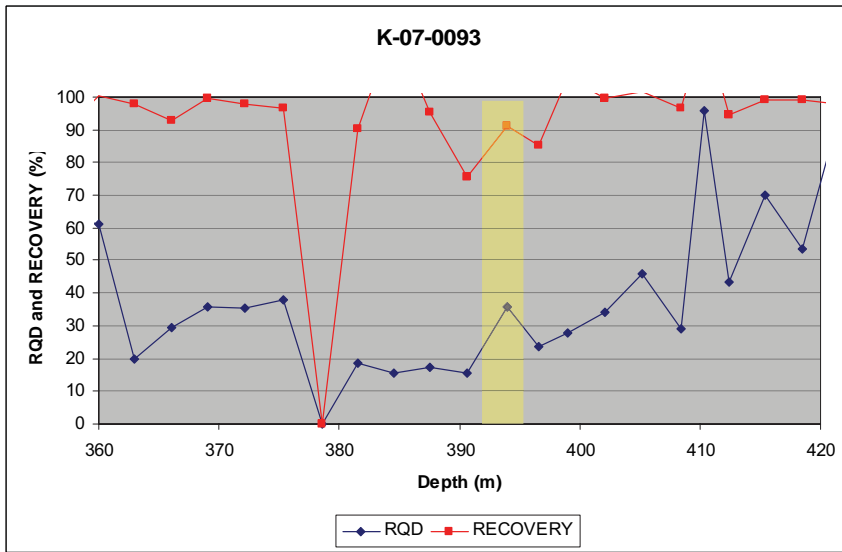

Notes:

- Orebody intercept length is apparent only.
- Orebody intercept inferred from modeled solids.

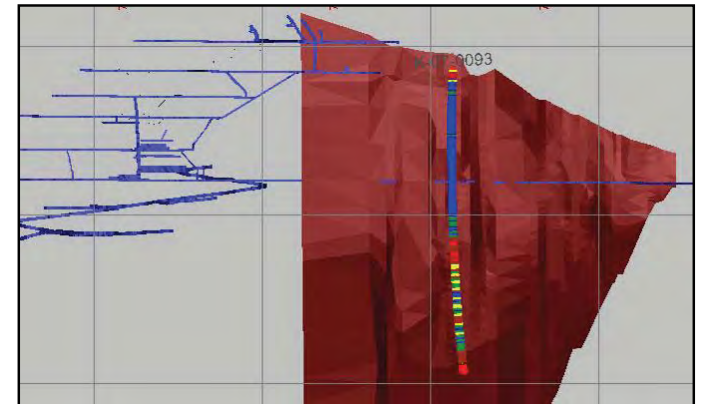

Bellekeno Project Geotechnical Evaluation			
Geotechnical Assessment of East Zone: K-07-0093			
PROJECT: 2CA017.000	DATE: June 2008	APPROVED:	FIGURE: C1

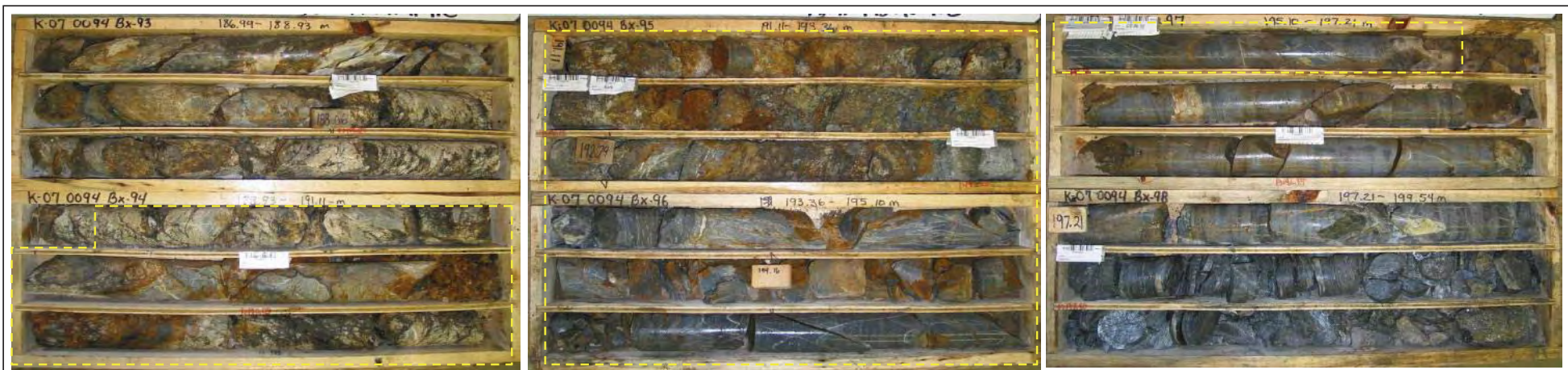

186.99 – 191.11m

191.11 – 195.10m

195.10 – 199.54m

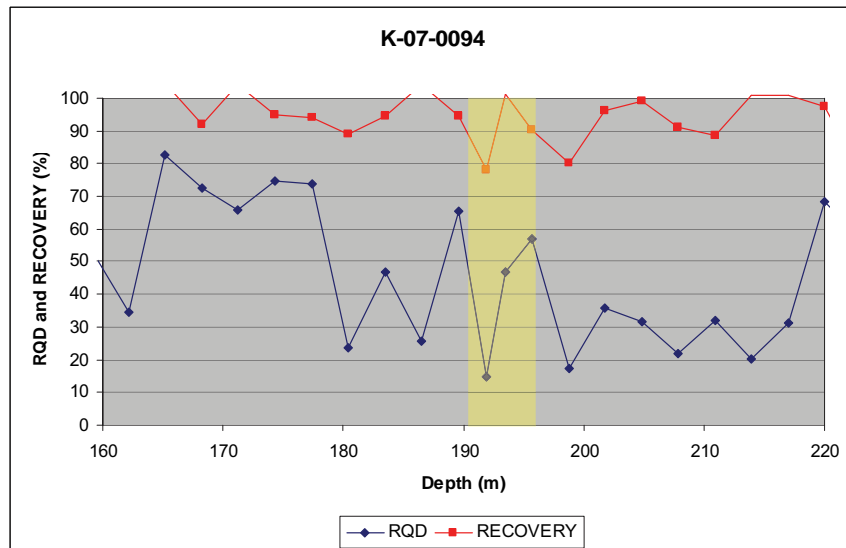

- Notes:
- Orebody intercept length is apparent only.
 - Orebody intercept inferred from modeled solids.

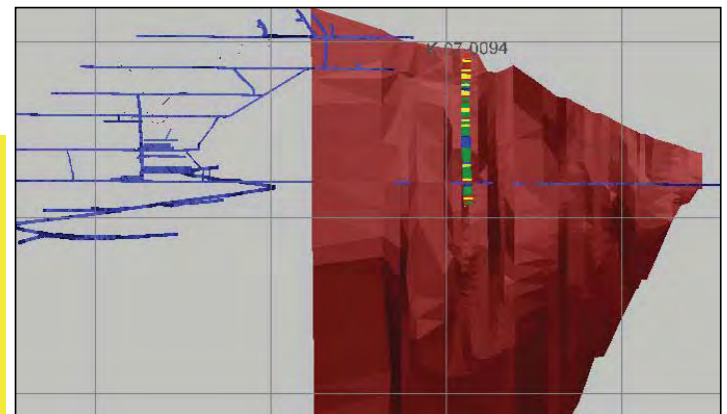

Bellekeno Project Geotechnical Evaluation			
Geotechnical Assessment of East Zone: K-07-0094			
PROJECT: 2CA017.000	DATE: June 2008	APPROVED:	FIGURE: C1



395.88 – 399.17m



399.17 – 402.55m



402.55 – 406.54m

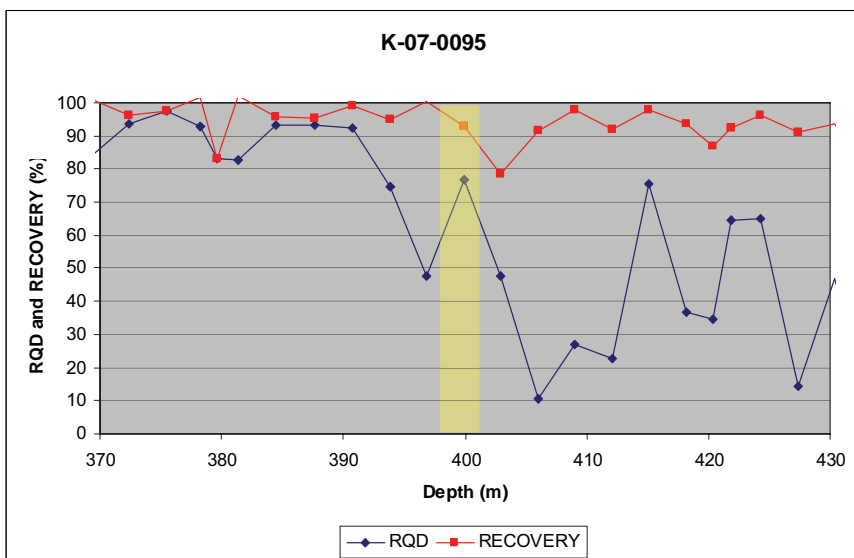

- Notes:
- Orebody intercept length is apparent only.
 - Orebody intercept inferred from modeled solids.

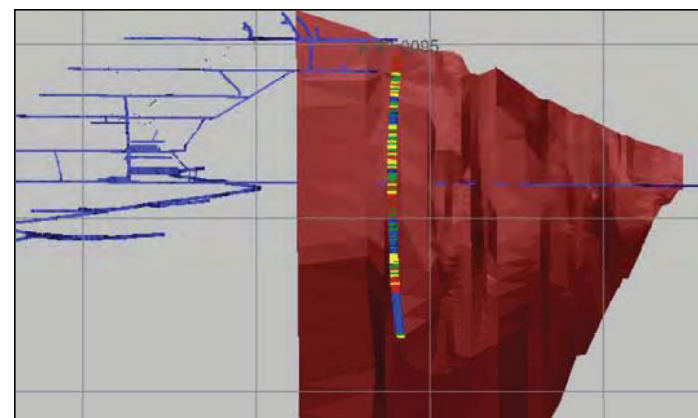



277.00 – 278.30m



278.30 – 282.21m



282.21 – 286.02m

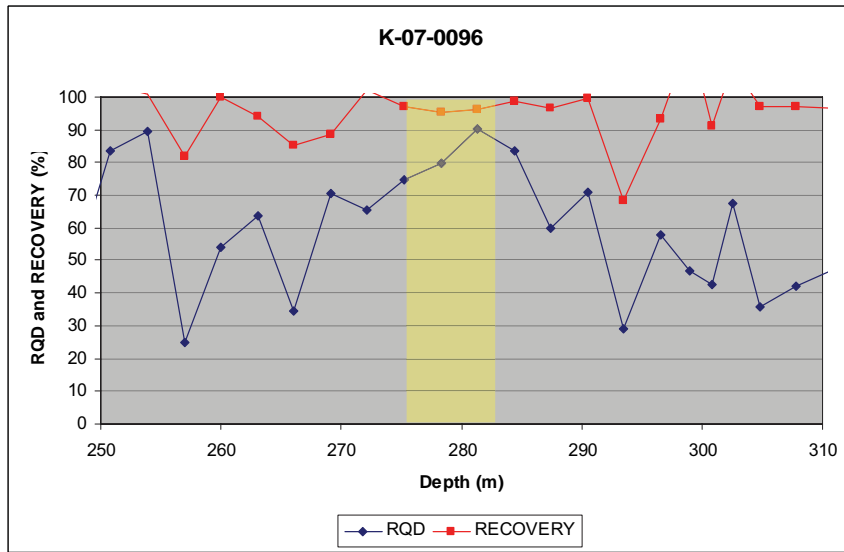

- Notes:
- Orebody intercept length is apparent only.
 - Orebody intercept inferred from modeled solids.

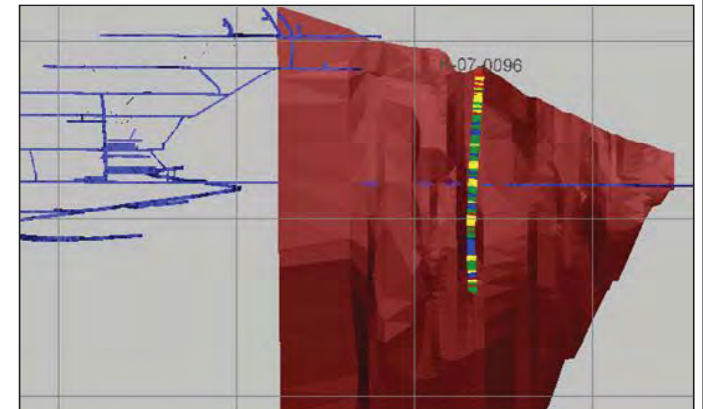

Bellekeno Project Geotechnical Evaluation			
Geotechnical Assessment of East Zone: K-07-0096			
PROJECT: 2CA017.000	DATE: June 2008	APPROVED:	FIGURE: C1

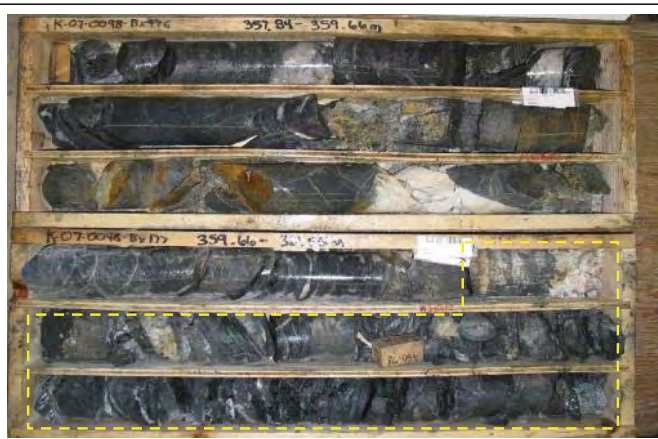

357.84 – 361.55m



361.55 – 365.71m



365.71 – 370.03m

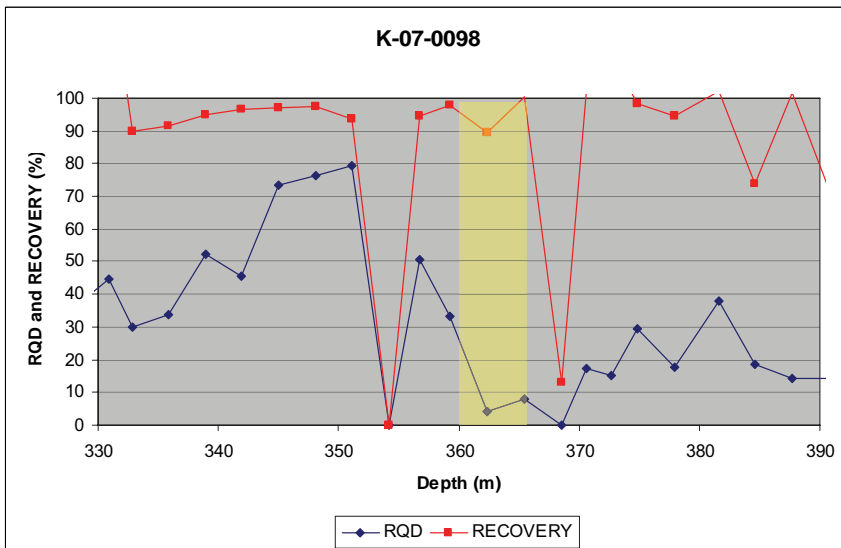

- Notes:
- Orebody intercept length is apparent only.
 - Orebody intercept inferred from modeled solids.

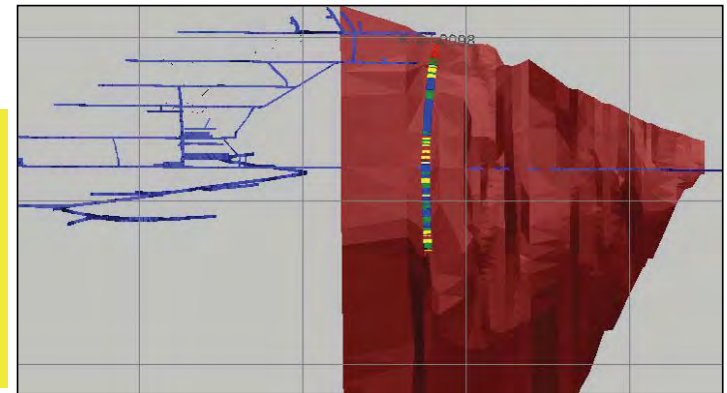

Bellekeno Project Geotechnical Evaluation			
Geotechnical Assessment of East Zone: K-07-0098			
PROJECT: 2CA017.000	DATE: June 2008	APPROVED:	FIGURE: C1

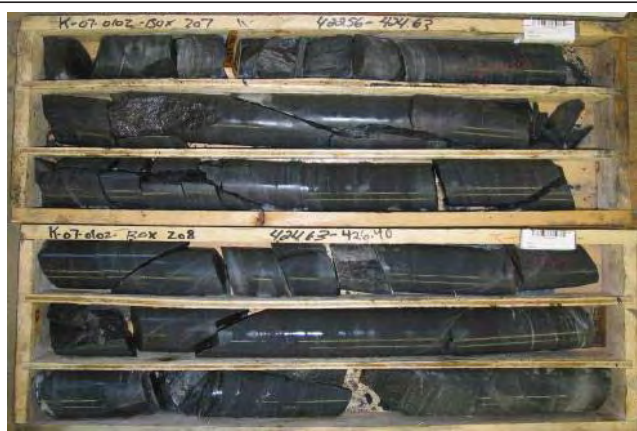

422.56 – 426.4m



426.4 – 430.69m



430.69 – 434.80m

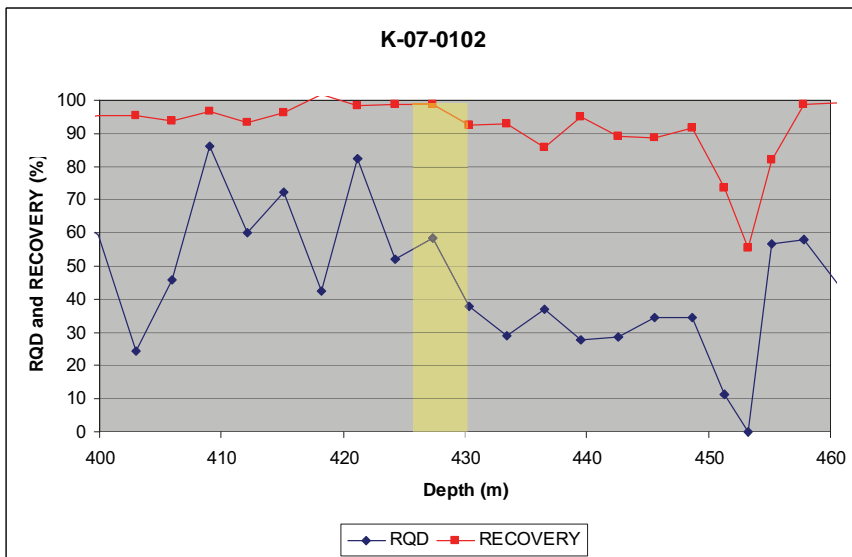

Notes:

- Orebody intercept length is apparent only.
- Orebody intercept inferred from modeled solids.

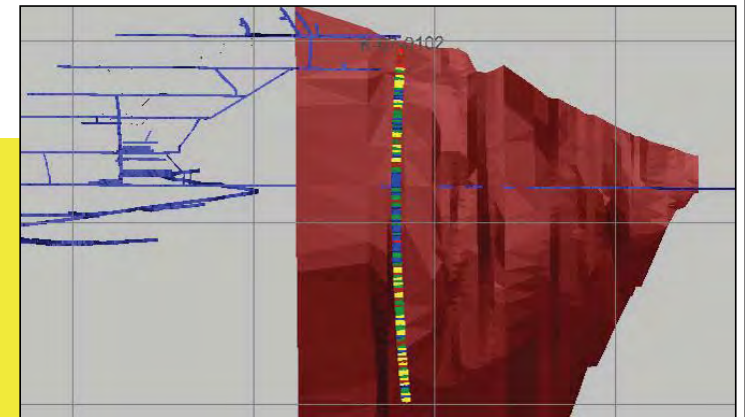

Bellekeno Project
Geotechnical Evaluation

**Geotechnical Assessment of East
Zone: K-07-0102**

PROJECT: 2CA017.000	DATE: June 2008	APPROVED:	FIGURE: C1
------------------------	--------------------	-----------	---------------

Type 1

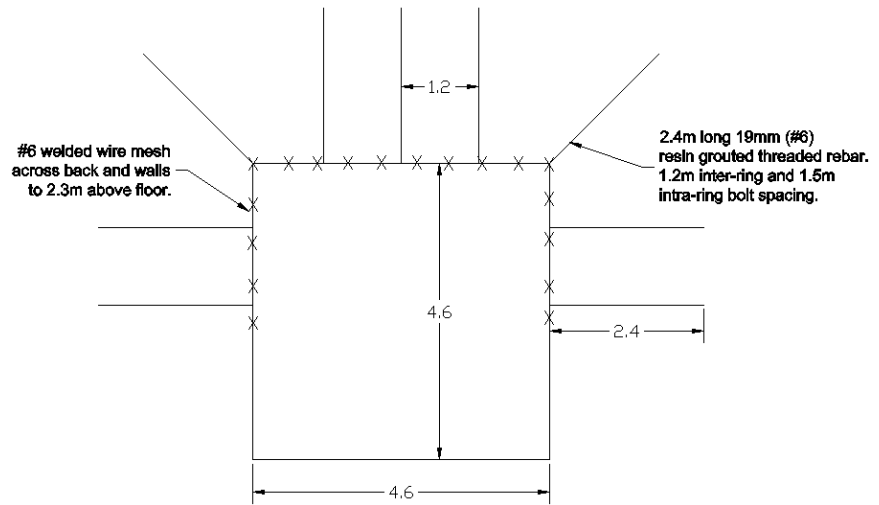

Type 2

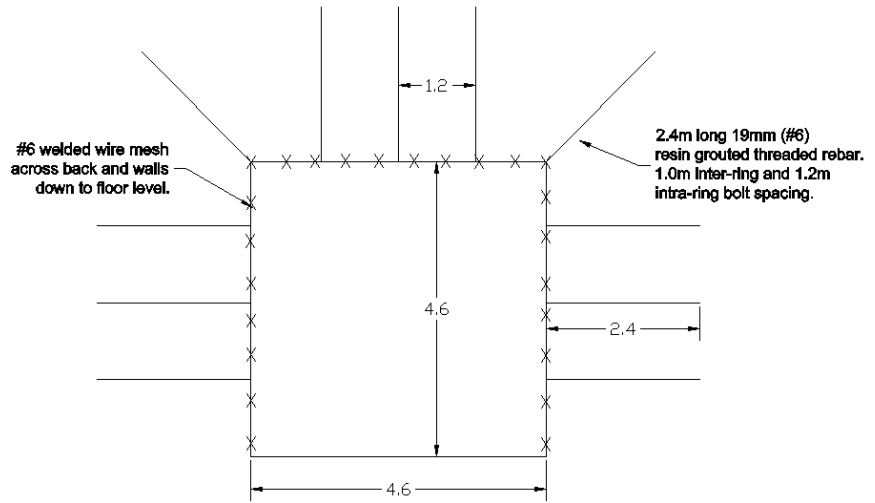

Type 3

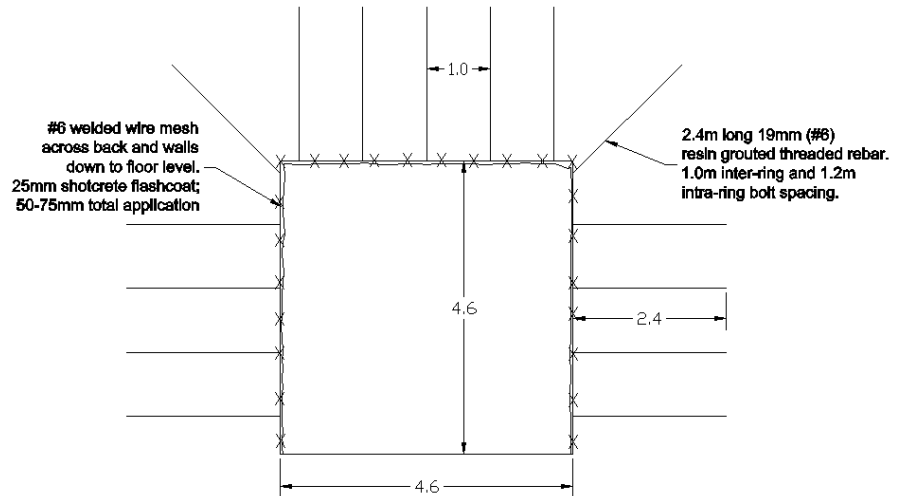

Bellekeno Project
Geotechnical Assessment

Development Headings: Support Standards

PROJECT: 2CA017.000	DATE: June 2008	APPROVED:	FIGURE: C3
------------------------	--------------------	-----------	---------------