



**AKHM**  
ALEXCO KENO HILL  
MINING CORP.

---

---

**ROAD CONSTRUCTION PLAN – KENO CITY BYPASS ROAD**

**KENO HILL SILVER DISTRICT MINING OPERATIONS**

**QML-0009**

---

---

**REVISION 1**

November 2012



## TABLE OF CONTENTS

1 INTRODUCTION.....	1
2 SITE DESCRIPTION .....	1
2.1 HISTORY.....	1
2.2 GEOLOGY .....	2
2.2.1 PROPERTY GEOLOGY .....	2
2.3 GENERAL ENVIRONMENTAL CONDITIONS.....	5
2.4 LIGHTNING CREEK .....	6
3 ROAD DEVELOPMENT OVERVIEW.....	6
3.1 ONEK ACCESS BRIDGE.....	6
4 SITE PREPARATION .....	7
4.1 CLEARING.....	7
4.2 HERITAGE RESOURCES PROTECTION .....	7
5 ROAD DESIGN AND SPECIFICATIONS.....	7
5.1 HAUL ROAD SPECIFICATIONS.....	7
5.1.1 HAUL ROAD DESIGN CRITERIA.....	8
5.1.2 HAUL ROAD CONSTRUCTION GUIDELINES .....	9
5.1.3 HAUL ROAD MAINTENANCE.....	9
5.1.4 HAUL TRUCK CLEANLINESS .....	10
5.2 ACCESS TIE-IN AND STAGING AREAS .....	10
5.3 ACCESS CONTROL .....	10
5.3.1 TEMPORARY ACCESS CLOSURE.....	10
5.3.2 PERMANENT ACCESS CLOSURE .....	11
6 BORROW SOURCES .....	11
7 GEOCHEMICAL EVALUATION .....	11
8 GEOTECHNICAL TESTING.....	11



9 BEST MANAGEMENT PRACTICES ..... 12

9.1 ENVIRONMENTAL MONITORING ..... 12

**LIST OF FIGURES**

Figure 1 Keno City Bypass Road Routing and Access Management ..... 14

Figure 2 Conceptual Road Design ..... 15

Figure 3 Typical Conceptual Road Section ..... 16

Figure 4 Typical Bridge Design ..... 17

**LIST OF TABLES**

Table 1 Keno Hill District Environmental Setting Summary ..... 5

Table 2 Road Design Criteria ..... 8

Table 3 Design Vehicle Volvo A30E ..... 9

Table 4 Road Construction Best Management Practices ..... 13

## 1 INTRODUCTION

Alexco Keno Hill Mining Corp. (Alexco) continues to develop the mineral resources of the Keno Hill Silver District (KHSD). As part of KHSD Mining Operations, AKHM will continue to establish access and haul roads on the site. This plan is intended to address construction, operation, and maintenance of site roads developed in support of AKHM mining activities and will be adapted as necessary for the construction of specific roads. Temporary and permanent closure of roads is addressed in the Keno Hill Silver District Mining Operations Reclamation and Closure Plan. The scope of this plan includes specifically the Keno City Bypass Road to accommodate mine traffic associated with Lucky Queen and Onek mining operations.

## 2 SITE DESCRIPTION

The KHSD lies within the traditional territory of the First Nation of Na-cho Nyak Dun (FNNND) and near the communities of Keno City and Mayo. The Keno Hill Silver District is located in central Yukon (63°54'32" N, 135°19'18" W; NTS 105M/14 & 105M/13), 354 km due north of Whitehorse. Access to the property is via the Alaska, Klondike and Silver Trail Highways from Whitehorse to Mayo and an all-weather gravel road northeast from Mayo to Elsa (45 km); a total distance of 452 km.

The KHSD is located on and around Galena Hill, Keno Hill and Sourdough Hill. The property lies along the broad McQuesten River valley with three prominent hills to the south of the valley. Lucky Queen is located approximately 4 km northeast of Keno City and Onek is situated about 500 m northeast of Keno City.

The Keno City Bypass Road routing is shown in Figures 1 and 2. The Bypass Road is required to accommodate mine traffic associated with the Lucky Queen and Onek mine sites. Its routing diverts mine traffic around Keno City rather than through the community.

### 2.1 HISTORY

The Keno Hill area was once host to one of the world's richest silver deposits. In 1903, the village of Mayo was established and the first silver claim was staked by Jacob Davidson on Galena Creek near present day Elsa. In 1918 Keno Hill was staked and claimed after the discovery of a significant silver deposit (Yukoninfo, n.d.). A silver rush occurred in the district and in 1919 John Kinman found a silver vein around Lightning Creek. His cabin became a stopping point and eventually, Keno City (Yukon Development Corporation, 2004). In 1921 the Treadwell Yukon Mining Company was formed, investing in various properties in the area. Elsa was claimed in 1924, on Galena Hill by Charlie Brefault. It was not developed until 1935 after the mill was moved to the vicinity. In 1947 the United Keno Hill Mines Limited (UKHM) took over the Treadwell properties, and began using the Elsa mill to process ore. The district was later consolidated by UKHM and United Keno Hill Minerals Limited (collectively "Keno Hill").

Together they became the second largest silver producers in North America and the fourth largest in the world during the late 1950s. The Elsa community grew to a population of approximately 700 in the 1980s during this boom. United Keno Hill Mines Ltd. was eventually forced into bankruptcy in 1989 due to the fall of metal prices. The property was declared abandoned in 2001. In 2005 Alexco purchased the assets of the

UKHM and United Keno Hill Minerals Limited, collectively becoming “United Keno Hill Mines Limited (UKHM)”. The Yukon Government approved the purchase agreement in December 2007 following the receipt of permits and approvals.

## 2.2 GEOLOGY

The Keno Hill Silver District is located in the western part of the Selwyn Basin in an area dominated by deformed and metamorphosed Upper Proterozoic to Mississippian sedimentary rocks formed at the edge of a continental margin. During the Jurassic and Cretaceous, the area was subjected to compressional tectonic forces producing two major thrust sheets (Robert Service and Tombstone) and widespread folding. Early large scale deformation produced recumbent folds, resulting in local structural thickening of strata. A second (and possibly third) deformational event produced gentle south westerly plunging syn- and antiform pairs.

The Robert Service Thrust Sheet in the south is composed of Late Proterozoic to Cambrian sandstone, locally with interbedded limestone and argillite, a Cambrian to Middle Devonian succession of siltstone, limestone and chert, and Upper Devonian argillite, chert, and chert pebble conglomerate. The latter unit uncomfortably overlies the lower units.

The Tombstone Thrust Sheet to the north consists of Devonian phyllite, felsic meta-tuffs and metaclastic rocks, overlain by Carboniferous quartzite. This latter rock unit is locally thickened due to folding and or thrusting and hosts the mineralization of the Keno Hill Silver District.

Intrusive rocks formed during four episodes of plutonism. Early Paleozoic fine-grained diabase occurs as metre-scale dikes and sills in the Upper Proterozoic to Lower Cambrian rocks. During the Mid-Triassic, gabbros to diorites formed pods of various sizes, primarily in the Devonian and Mississippian rocks of the Tombstone thrust sheet. A third phase of plutonism took place around ninety-two million years ago in the early Cretaceous and resulted in widespread and voluminous Tombstone intrusions of commonly granitic to granodioritic composition. The youngest magmatic activity occurred around sixty-five million years ago in the Upper Cretaceous and resulted in the formation of peraluminous megacrystic potassium feldspar granite.

In addition to where polymetallic veins were exploited, the area hosts a number of occurrences, and showings of tungsten, copper, gold, lead, zinc, antimony and barite. Tin, tungsten, and molybdenite occurrences are possibly related to the suite of Cretaceous intrusion, whereas lead, zinc, and barite occur in stratiform calcareous sedimentary rocks of early to mid-Paleozoic age typical of sediment-hosted deposits.

### 2.2.1 Property Geology

The Keno Hill District is underlain primarily by Yukon Group metasedimentary rocks, locally divided into three formations; Upper Schist, Central Quartzite and Lower Schist. The Upper Schist (Hyland Group, pre-Cambrian to Cambrian age) overlies the quartzite in what is inferred to be a thrust contact (Robert Service Thrust) and consists of quartz-mica schist, quartzite, graphitic schist and minor limestone. The Central Quartzite (Keno Hill Quartzite, Mississippian age) contains thick and thin-bedded quartzite, massive quartzite, graphitic phyllite, graphitic schist, calcareous schist and minor Triassic greenstone. This unit is approximately 700 m thick and is host to most of the past producing ore bodies. Structurally juxtaposed below the quartzite is the Lower Schist which has been correlated with the Devonian-Mississippian Earn

Group. The Lower Schist includes graphitic schist, argillite, thin-bedded quartzite, calcareous schist, phyllite, slate, sericite schist, minor thick-bedded quartzite and locally significant intervals of Triassic greenstone. The greenstone forms sills and/or boudins and consists of metadiorite and metagabbro. The sills and boudins form bodies up to one kilometre long and thirty metres thick. Regional, greenschist facies metamorphism of all units is believed to have occurred in the Middle Cretaceous, about 105 million years ago.

A number of quartz-feldspar porphyritic sills have intruded the stratigraphy parallel to schistosity. The sills are most common in the Lower and Upper Schists and can reach thicknesses of up to fifty metres; reports of occurrences in the Central Quartzite are inconclusive and vague. The quartz-porphyry sills are believed to be of Cretaceous age.

Structurally, the property is characterized by four sets of faults; many of which have been filled by hydrothermal minerals, forming veins. The oldest fault set consists of south dipping structures that are generally parallel to foliation and are apparently associated with the Tombstone Thrust Fault since movement was contemporaneous or slightly later. Locally, brittle deformation has been observed along these structures. A second fault set, known as “longitudinal veins” strikes north east to east northeast and dips

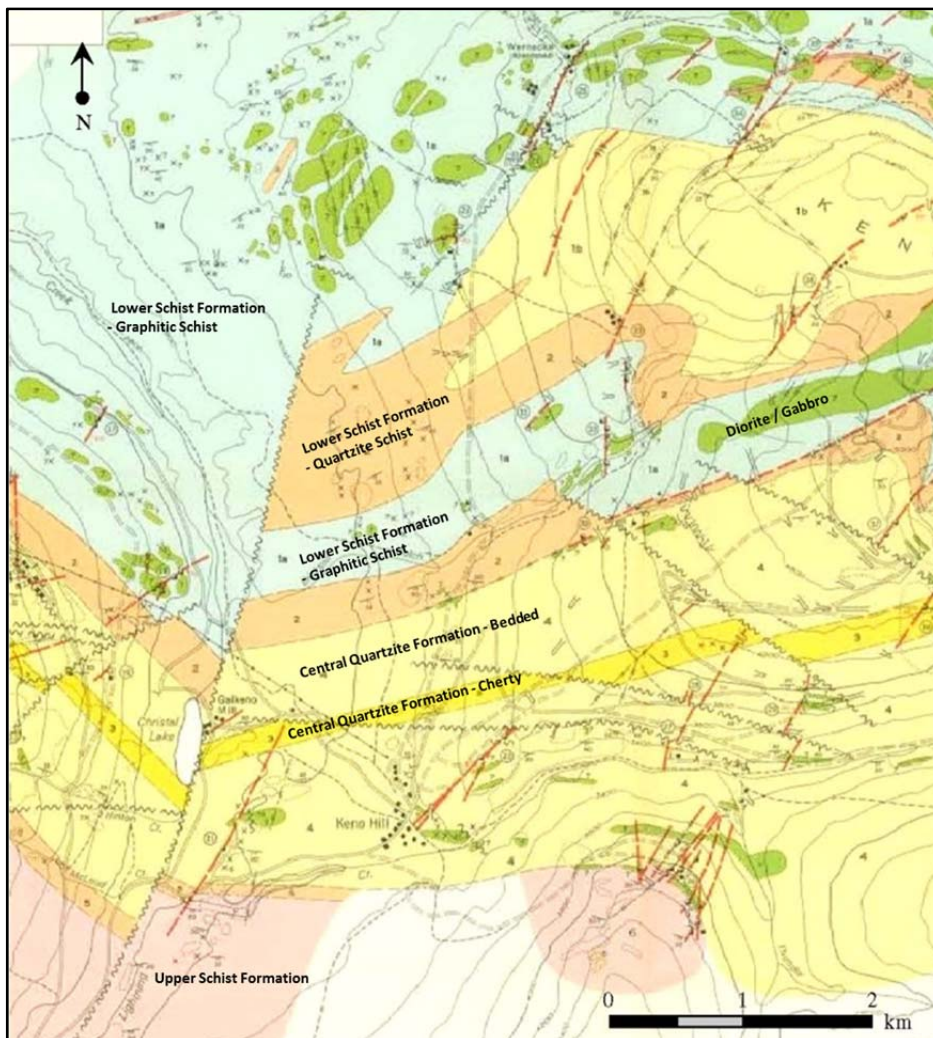

steeply southeast. The latest movement along these faults is sinistral with offsets locally reaching more than 150 metres; however, more than one episode of movement commonly is indicated. Depending on the competency of the host rock, longitudinal veins can be up to thirty metres wide in an anatomising system of sub-veins. Essentially all mineralized rock was mined from these longitudinal veins. A third set of faults, known as “transverse faults”, is north-west striking and dips steeply to the north. Transverse faults typically do not contain silver and lead mineralization but are commonly filled by quartz with trace to minor arsenopyrite, pyrite and jamesonite.

A younger set of faults, known as cross faults, strike north to north east with a dip of sixty degrees west to south west and offset vein or longitudinal faults by up to 2,000 m. In the western part of the property, dextral movement is the most recent event along these structures, whereas in the eastern part of the property sinistral movement with less magnitude prevails.

At Keno Hill, the largest accumulation of ore minerals occurred in structurally prepared competent rocks, such as the Central Quartzite, resulting in areas of increased fluid flow. Incompetent rocks like phyllites tend to produce fewer and smaller, if any, open spaces, limiting fluid flow and resulting mineral precipitation.

Mineralization in the Keno Hill Silver District is of the polymetallic silver-lead-zinc vein type. In general, common gangue minerals include manganiferous siderite and to a lesser extent quartz and quartz breccia as well as calcite and other carbonates. Silver occurs in argentiferous galena and argentiferous tetrahedrite (freibergite). In supergene assemblages, silver is further found as native silver, in polybasite, stephanite, and pyrargyrite. Lead occurs in galena and zinc in sphalerite, which is iron-rich. Other sulphides include pyrite, arsenopyrite (locally gold-bearing) and chalcopyrite.

The veins of the Keno Hill Silver District display characteristics associated with both mesothermal and epithermal deposits and it is not clear if a continuum exists or if separate and distinct mineralizing events are involved. The most prominent examples of epithermal style mineralization are found in the western part of the district, although the Lucky Queen mine on Keno Hill produced native silver and ruby silver in quantity. Proximity to a magmatic heat source has often been called upon to explain the district zonation, though this is by no means a complete explanation.

Mineral zoning within individual oreshoots is less clearly documented, although there has long been a conviction that silver and lead rich zones occur higher in the veins while zinc becomes dominant at depth. Anecdotal evidence suggests that vertically stacked oreshoots may repeatedly show zoning of lead rich upper portions to zinc dominant roots, but data confirming this has not been found. In general, Pb-Zn mineralization appears to be nearly contemporaneous in age.

Mechanisms triggering deposition of ore and gangue minerals have been suggested by district wide studies of fluid inclusions and light stable isotopes. Fluid boiling appears to have been ubiquitous and some evidence exists for fluid mixing. The hydrothermal fluids responsible for mineral deposition contained significant quantities of CO<sub>2</sub> which may have “boiled” during abrupt changes in pressure produced during fluid movement from confined fractures to more open conduits formed in quartzite.

Irrespective of stratigraphic formations or regional map units only a few major rock types are commonly encountered in the area of the old mine workings. These are:

- schists and phyllites with variable carbon content;
- chloritic phyllites or schists;
- quartzites and phyllitic quartzites;
- sericite-quartz phyllites; and,
- greenstones.

### 2.3 GENERAL ENVIRONMENTAL CONDITIONS

Table 1 summarizes existing environmental conditions in the Keno Hill project area. The Keno Hill Silver District lies within the Yukon Plateau – North Ecoregion, just south of the Wernecke Mountains. The terrain consists of concordant, rolling, upland areas separated by wide valleys. Alpine mountain peaks extend above the uplands locally. Many valleys include peatlands, palsas, fens and meadows of sedge tussocks. Upper slopes may be covered with scree material, with treeline occurring at 1,350 to 1,500 m. The area has been influenced by the latest glaciation but shows more subtle evidence of an earlier event as well.

**Table 1 Keno Hill District Environmental Setting Summary**

Drainage Region	Stewart River drainage region
Significant Watersheds	McQuesten River, Lightning Creek and Stewart River Watershed, Mayo River
Ecoregion	Yukon Plateau (North)
Study Area Elevation	900-1350 m asl (Above Sea Level)
Vegetation Communities	Northern boreal forests occupy lower slopes and valley bottom; spruce, pine and alder; grasses and sedges, mosses occupy forest floor; heavy moss and lichen growth resident as ground cover understory of shrub willow; open and forest fringe areas of willow and scrub birch, and various flowering plant species.
Wildlife Species	Moose, grizzly and black bear, caribou, beaver, wolf, lynx, marten, wolverine, western tanager, magnolia warbler, white-throated sparrow, bald eagle, furbearers and small animals.  Committee on the Status of Endangered Wildlife in Canada (COSEWIC) listed species include: Common Nighthawk (Threatened); Rusty Blackbird and Olive-Sided Flycatcher (Special Concern).
Fish Species	Bering and Beaufort Sea salmonids and freshwater species, including: Arctic grayling, Arctic char, lake trout, trout perch, lake whitefish, broad whitefish, burbot, inconnu, Arctic Cisco, Northern pike, slimy sculpin

## 2.4 LIGHTNING CREEK

Lightning Creek is situated within a narrow valley with a steep gradient flowing from the north side of Sourdough Hill into Duncan Creek, which drains into the Mayo River. Hope and Thunder Gulches flow into Lightning Creek within the bounds of the Keno Hill Silver District (KHSD). Lightning Creek has also been the site of extensive placer mining upstream of Keno City both historically and at present time. The Lightning Creek drainage has also been affected by localized quartz mining activities including the Bellekeno Mine which was re-opened by Alexco in 2011. Mine adit drainages from Bellekeno 625 (north side of Sourdough Hill) and Keno 700 (south side of Keno Hill) eventually report to the Lightning Creek drainage. Lightning Creek is notable as it is the only large watershed in the KHSD not connected to the South McQuesten River. Lightning creek drains into the Duncan Creek watershed which flows south into the Mayo and Stewart River.

## 3 ROAD DEVELOPMENT OVERVIEW

The Keno City Bypass Road will be developed from the Wernecke Road, crossing Sign Post Road, along the historic Onek power line, to the Onek 990 Portal, crossing Lightning Creek Road and the Onek Access Bridge across Lightning Creek to the Bellekeno Haul Road. The Bypass Road will be a single-lane radio-controlled road, approximately 2.1 km long and 6 – 9 m wide. Some portions of the road will be wide enough to safely accommodate passing mine traffic. It will be developed with cut/fill construction, using the fill material supplemented by some additional N-AML waste rock material (~15,000 m<sup>3</sup> in total required). The N-AML waste rock will be sourced from Onek or Bellekeno. Initial development of the Bypass Road may require N-AML from the historic Onek waste dump adjacent to the Bypass Road, until sufficient volumes of N-AML material are available from the Onek 990 decline development.

The routing does not cross or come within 30 m of any watercourse or waterbody other than at the approach to Lightning Creek and at the Onek access bridge. Ditching along the road will facilitate appropriate drainage. Culverts will be installed at the intersections with Wernecke Road, Lightning Creek Road, Bellekeno Haul Road and Sign Post Road for drainage. Additional culverts may be established along the bridge approaches. The cleared vegetative debris and topsoil will be stockpiled along the routing in natural cleared areas for road reclamation.

### 3.1 ONEK ACCESS BRIDGE

The Keno City Bypass Road routing includes crossing Lightning Creek, which will require installation of the bridge. AKHM proposes to install a clear span (single span) bridge across Lightning Creek. The bridge will be a single-lane, steel girder prefabricated bridge, approximately 9 m long and 4.4 m wide. The bridge is designed to have the flow capacity of a 1:100 year flood event; it will be capable of supporting mine haul traffic (at least 100 t). An engineered typical Lightning Creek bridge design is provided in Figure 3.

A 6.5 m wide access road will be established on the north and south side of Lightning Creek to the bridge site. Two overflow culverts will be installed within the 1:100 year flood event zone. Fill material for the access road and abutments will be sourced from Onek and Bellekeno N-AML waste rock. The banks and riparian area will be cleared with a brush mower or pushed aside with a dozer.

The proposed site for the clear span bridge design crossing was selected by Alexco engineering personnel and in consideration of riparian and flow regime conditions.

Bardusan Placers Ltd. holds the placer claims at the site of the proposed Onek Access Creek Bridge. The placer rights holder has been contacted with respect to bridge location. The placer claim owner is not currently operating any placer mining activity on the claims at the proposed bridge crossing location.

AKHM installed a clear span bridge on Lightning Creek, approximately 1.1 km downstream of the proposed Onek Access Bridge site (Type B Water Licence MS10-029). Pursuant to the *Navigable Waters Protection Act*, Transport Canada determined that Lightning Creek is a Non-Navigable waterway at the location of the existing bridge (see email from Transport Canada – YOR Document 2009-0030-120-1). It was determined to be not navigable because there is a culvert upstream of the existing bridge. The proposed Onek Access Bridge is located approximately 586 m upstream of the culvert.

The Onek Access Bridge will be licenced under an amendment to the existing MS10-029.

## **4 SITE PREPARATION**

### **4.1 CLEARING**

In general, a dozer will be used for clearing. An excavator will be used as required. The road routing does not come within 30 m of a watercourse with the exception of the approaches and crossing Lightning Creek. Banks and riparian areas will be cleared with a brush mower or chainsaw. Trees within 10 m of Lightning Creek will be close cut and stumps left in place.

### **4.2 HERITAGE RESOURCES PROTECTION**

The road routing has been ground-truthed by Alexco officials and a knowledgeable community member. No heritage resources were located within the road ROW. Alexco's Heritage Resources Protection Plan for Keno Hill Silver District Mining Operations will be applied.

## **5 ROAD DESIGN AND SPECIFICATIONS**

### **5.1 HAUL ROAD SPECIFICATIONS**

All haul roads, Bellekeno Haul road, Lucky Queen Haul road, and the Keno City Bypass road will be subject to Part 15.42 and 15.43 of the Yukon Occupational Health and Safety Regulations, which set out minimum design criteria for safety considerations. In addition, mine haul road design guidelines developed by the University of Alberta (Tannant and Regensburg, 2001) and which were referenced during the development of the road plans.

### 5.1.1 Haul Road Design Criteria

Civil design criteria for haul roads were developed by Wardrop Engineering Inc. based on applicable federal and territorial codes and regulations, as well as industry standards and other reference documents (Appendix D of the Construction Site Plan, Revision 1). The road design criteria are shown in Table 2. The design vehicle used as the basis of design criteria is shown in Table 3. Figure 4 shows a typical road cross-section.

**Table 2 Road Design Criteria**

Haul Road	
Operating Width*	5.88 <sup>1</sup> or 8.82 <sup>2</sup> m
Design Speed	50 km/hr
Cross fall	2%
Maximum Grade	8%
Surface	200 mm
Base	300 mm
Sub-base	500 mm
Cut Side Slope	1.5 : 1
Fill Side Slope	2 : 1
Subgrade Compaction	>80%
Granular Compaction	>85%

\* Excludes berms and ditches on both side of haul roads.

1. One way traffic.
2. Two way traffic (passing).

**Table 3 Design Vehicle Volvo A30E**

Volvo A30E	Dimension	
Width	2.94 m	
Length	10.3 m	
Height	3.3 m	
Wheel Base	2.216 m	
Tire Pressure	267 kPa	
Weight	Loaded	Empty
Gross Vehicle Weight	51 060 kg	28 000 kg
Front Axle	14 990 kg	12 500 kg
Drive Axle	36 070 kg	15 560 kg

### 5.1.2 Haul Road Construction Guidelines

General guidelines for haul road construction include:

- Haul roads shall be all-weather construction;
- Safety berm will be constructed on all fills >3.0m;
- Height of safety berm will be 1.25m (0.75x the diameter of tire on Volvo A30E articulated haul truck);
- Breaks in the safety berm will not exceed the width of the blade of the equipment constructing and maintaining the breaks to allow for drainage and snow clearance;
- Sideslope will be maximum 2:1 if embankment is between 0-3 m;
- Sideslope will be maximum 1.5:1 if embankment is between >3 m;
- Alternating vehicular pull-outs will be used at each end of one way traffic road segments;
- Pull outs length equals 1.5 times the vehicle length;
- Pull outs width equals 1.5 times the operating width; and
- A clearly marked emergency runaway lane or retardation barrier capable of bringing a runaway vehicle to a stop will be provided and maintained below where road grade exceeds 5%.

### 5.1.3 Haul Road Maintenance

Periodic grading and resurfacing as deemed necessary will be employed in order to keep the haul roads in good repair. During the winter, haul roads will be plowed and sanded to ensure proper traction is maintained.

#### **5.1.4 Haul Truck Cleanliness**

Haul trucks will be subject to periodic maintenance at the District Mill site. This maintenance will include washing, with care taken that all wash water be recycled or directed to the water treatment pond.

### **5.2 ACCESS TIE-IN AND STAGING AREAS**

The Keno City Bypass Road will intersect with Wernecke Road, Sign Post Road, Lightning Creek Road and the Bellekeno Haul Road.

Existing disturbance areas along the Keno City Bypass Road the Onek 990 Portal Pad will be used for staging construction equipment and material (e.g., N-AML waste rock). Fuel will be stored in the designated fuel storage area with appropriate containment on the Onek 990 portal pad. Explosives will be stored on the Onek historic waste dumps in accordance with applicable regulations.

No fencing or gating will be required. The following section describes access control measures.

### **5.3 ACCESS CONTROL**

There will be stop signs to stop mine traffic at the intersections with Wernecke Road, Sign Post Road and Lightning Creek Road. Signage warning of crossing mine traffic will be installed in both directions from the intersection, in accordance with regulatory requirements. Appropriate line-of-sight distances will be maintained to ensure crossing trucks and approaching traffic on the Wernecke Road are able to see each other. The line-of-sight distance requirements of YG Highways & Public Works Transport Branch and the Highway Access/ Works within a Right-of-Way permits will be adhered to in order to ensure public and worker safety.

Signage warning of crossing/turning mine dump trucks (over the highway dump trucks) will be installed along Sign Post Road, Lightning Creek Road, Bellekeno Haul Road and Wernecke Road in accordance with the requirements and direction of YG Highways & Public Works Transport Branch officials.

The Keno City Bypass Road is intended for mine personnel use. No gates will be used. The Keno City Bypass Road will be a radio controlled road accessible to mine traffic only. Signs will be installed at the road access points prohibiting public traffic from traveling on it. The maximum speed limit will be 40 km/h, reduced to 20 km/h at blind corners and road crossings.

#### **5.3.1 Temporary Access Closure**

To limit access during temporary closure, pylons and signage will be used to warn road users, and gates will be installed, as required. The bridge will not be decommissioned during a temporary closure.

### 5.3.2 Permanent Access Closure

The bridge will remain in place during the life of the project (~15 years). Decommissioning measures will involve removal of the clear span bridge, abutments and culverts. The access roads will be decommissioned, regraded and re-sloped. All disturbed areas will be scarified and re-vegetated. The banks will be stabilized through revegetation and strategic placement of the existing rip rap. These decommissioning measures are incorporated into the Reclamation and Closure Plan.

## 6 BORROW SOURCES

The Keno City Bypass Road from Wernecke Road to the bank of Lightning Creek at the bridge crossing (~15,000 m<sup>3</sup> of material), and the Onek 990 Portal Pad (~4500 m<sup>3</sup> of material) will be constructed with fill from the cuts and Onek N-AML. If required, borrow material from the historic Onek waste dump adjacent to the Bypass Road will be used for initial development until sufficient volumes are available from the decline development.

Bellekeno N-AML waste rock will be used for constructing the section of access from the bridge to the Bellekeno Haul Road (~4,800 m<sup>3</sup>).

After initial development and establishment of the Onek Access Bridge, Onek or Bellekeno N-AML waste rock may be used for maintenance, upgrades or general construction purposes.

## 7 GEOCHEMICAL EVALUATION

The Keno Hill Silver District Mining Operations Waste Rock Management Plan (WRMP) will be applied to selecting N-AML material appropriate for construction. Where blasting is required for road construction, material from the blast face will be sampled to ensure it meets the WRMP N-AML criteria. If it doesn't adaptive management actions will be taken to address the rock exposure (e.g. shotcreting).

## 8 GEOTECHNICAL TESTING

AKHM engineers groundtruthed the road alignment to ensure geotechnical stability of the road bed. Some of the routing follows areas of existing linear disturbance (e.g. the historic Onek powerline ROW). To the extent possible, routing with sufficient overburden underlain with competent rock was selected. Areas showing signs of underlying permafrost (stunted trees, ground slumping) were avoided to the extent possible. In areas of potential permafrost (e.g. portion of Keno City Bypass Road south of Lightning Creek to the Bellekeno Haul Road), ground protection measures, such as installation of additional road foundation material, will be applied. Refer to Table 4 for additional mitigation measures.

## 9 BEST MANAGEMENT PRACTICES

Table 2 outlines the Best Management Practices that AKHM will apply to road construction, maintenance and closure activities in order to protect environmental conditions.

### 9.1 ENVIRONMENTAL MONITORING

In accordance with clause 53 of QZ09-092, between May and October of each year, Alexco will inspect all unlined waste rock locations, which in this case apply to the road because N-AML waste rock is to be used as construction material. As per clause 60, waste rock reporting requirements include recording in the annual report:

- 60. a) any physical instability including erosion;
- b) upstream ponding of water and downstream seepage;
- c) the location of ponding and seepage;
- d) the volume of flow, field pH and conductivity of ponding or seepage;
- e) visual evidence of sulphide oxidation including snow melt areas or the presence of oxidation products; and
- f) trends in pH, and conductivity for any recurring seepage or ponding location.

The Adaptive Management Plan stipulates that seepage from all structures constructed of N-AML waste rock shall be sampled for field pH and conductivity and flow. Additional water quality analysis is to be conducted if the seepage quantity is sufficient.

To date, no seeps have been detected from N-AML waste rock structures.

**Table 4 Road Construction Best Management Practices**

Environmental Component	Mitigation
Runoff, Sediment and Erosion Control	<ul style="list-style-type: none"> <li>• The road will be graded to allow surface water to drain off the road. Any runoff that drains from the road surface or staging areas will be conveyed into permeable roadside ditches and culverts and will likely infiltrate into the subsurface. During large storm events it is expected that some runoff volume will reach lightning creek. It is expected this volume will not be large enough to cause flooding issues downstream because the road area represents a very small percentage of the overall watershed area.</li> <li>• As part of road maintenance, ruts that could be prone to erosion will be filled.</li> <li>• Vegetation removal will be minimized to the extent possible.</li> <li>• Water bars will be constructed to promote proper drainage, if required.</li> <li>• During bridge construction/ adjacent road development, temporary sediment control, such as silt fences or temporary diversion berms, will be installed, monitored and maintained to prevent sediment runoff into the creek.</li> <li>• If minor rutting is likely to occur, stream bank and bed protection methods (e.g. swamp mats, pads) shall be used provided they do not constrict flows or block fish passage.</li> </ul>
Dust Control	<ul style="list-style-type: none"> <li>• Application of water or non petroleum dust suppression agents will be employed if required to control fugitive dust from haul road surfaces during the summer months. Run of mine ore from underground operations is generally wet, coarse grained and free of fines and will not create dust.</li> </ul>
Site Isolation	<ul style="list-style-type: none"> <li>• During bridge construction and adjacent road development, banks and riparian areas will be cleared with a brush mower or chainsaw. Trees within 10 m of Lightning Creek will be close cut and stumps left in place.</li> </ul>
Culvert Installation	<ul style="list-style-type: none"> <li>• An overflow culvert will be installed on each side of the bridge crossing within the 1:100 year flood event zone. These are to be placed above the ordinary high water mark and therefor will not have any effect on Lightning Creek aquatic life. The banks and riparian area will be cleared with a brush mower or chainsaw within 10 m of the stream bank. Stumps and root systems will be left in place to preserve natural erosion protection. All other storm water management culverts will be constructed to divert water beneath the roadway between road ditches and will not impact existing stream systems.</li> </ul>

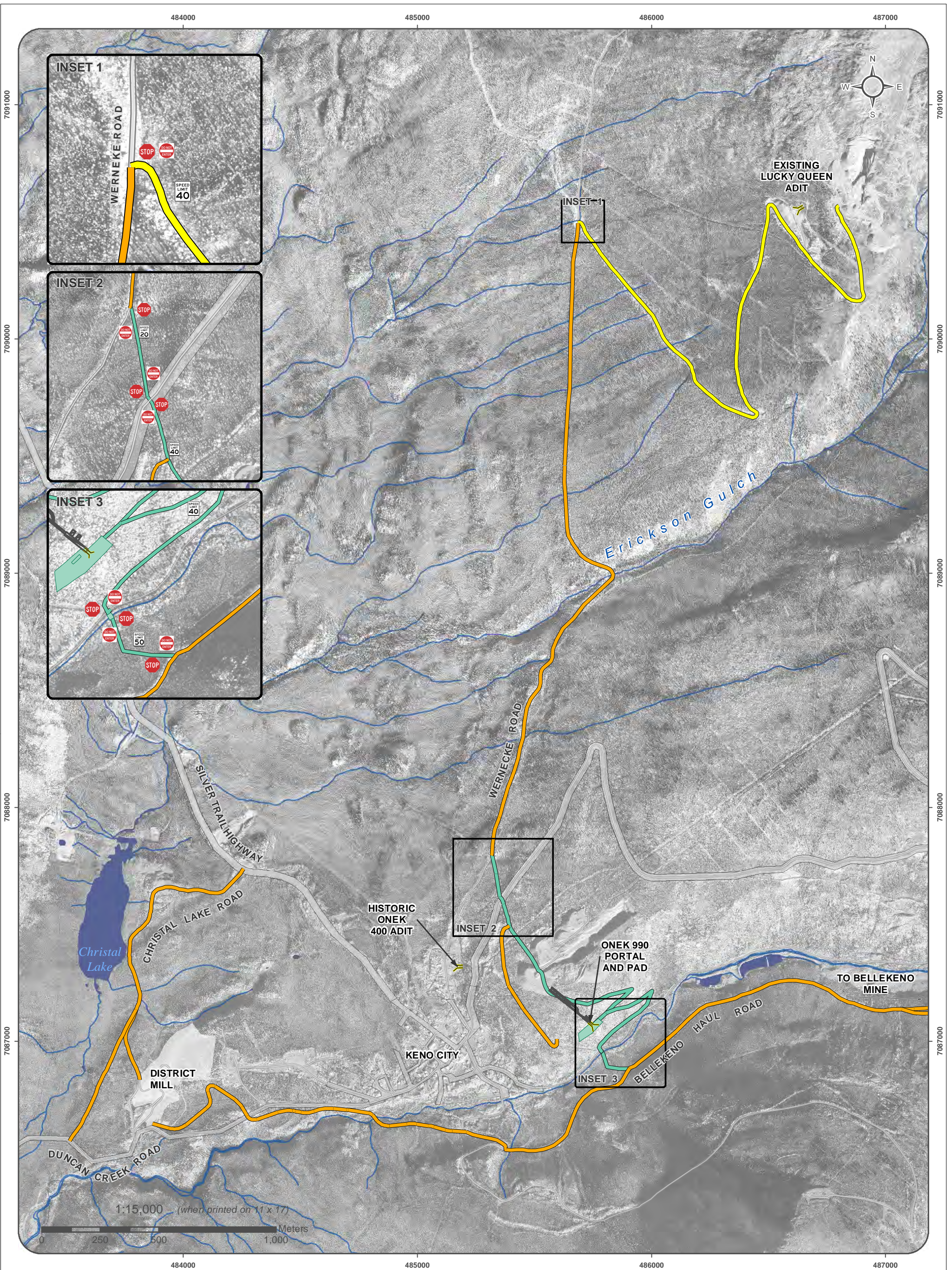

- Existing Private Road, Haul Road
- Proposed Private Road, Haul Road
- Existing Public Road, Haul Road
- Road Right of Way
- Watercourse
- Waterbody

This map is for illustrative purposes only. This is not a legal document. Quartz claim boundaries are current as of March 26, 2012. Placer claim boundaries are current as of Feb 26th, 2012. Land Disposition data obtained from Canada Lands Survey System, current as of March 2012. Site hydrography and contours derived from 2006 aerial imagery obtained from Aero Geometrics, Calgary Alberta. Aerial photograph obtained from Geodesy Remote Sensing Inc., Calgary Alberta. Imagery acquired September 13<sup>th</sup> and 14<sup>th</sup> 2006.

Datum: NAD 83; Projection: UTM Zone 8N

This drawing has been prepared for the use of Access Mining Consultants Ltd.'s client and may not be used, reproduced or relied upon by third parties, except as agreed by Access Mining Consultants Ltd. and its client, as required by law or for use of governmental reviewing agencies. Access Mining Consultants Ltd. accepts no responsibility, and denies any liability whatsoever, to any party that modifies this drawing without Access Mining Consultants Ltd.'s express written consent.



ALEXCO KENO HILL MINING CORP.  
ONEK AND LUCKY QUEEN

FIGURE 1 (REVISED)

**KENO CITY BYPASS ROUTING AND  
ACCESS MANAGEMENT**

DRAWN BY MD	NOVEMBER 2012	VERIFIED BY KW
-------------	---------------	----------------

E:\Keno\_Area\_Mines\ONE KMaps\2\_Permitting\Traffic\Road\_Construction\_Bypass\_Plan\_20121114.mxd  
(Last edited by: jgan 11/14/2012 15:07 PM)

**KENO HILL  
SILVER DISTRICT MINING  
OPERATIONS**

**FIGURE 2 (REVISED)  
CONCEPTUAL ROAD  
DESIGN**

- Profile A Distance Markers (distance in meters)
- Profile A
- Profile B
- Existing Roads

**NOT FOR  
CONSTRUCTION**

Profiles derived from 1 meter contour data derived from 2006 aerial imagery obtained from Aero Geometrics, Calgary Alberta and Site hydrography and contours derived from 2006 aerial imagery obtained from Aero Geometrics, Calgary Alberta.

NAD 83 UTM Zone 8N

NOVEMBER 2012



This drawing has been prepared for the use of Access Mining Consultants Ltd.'s client and may not be used, reproduced or relied upon by third parties, except as agreed by Access Mining Consultants Ltd. and its client, as required by law or for use of governmental reviewing agencies. Access Mining Consultants Ltd. accepts no responsibility, and denies any liability whatsoever, to any party that modifies this drawing without Access Mining Consultants Ltd.'s express written consent.

I:\keno\_Area\_Mines\ONEK\Map01\_Overview\_Maps\Roads\ProposedRoad\_20121119.mxd  
(Last edited by: medchamr; 18/11/2012 15:19 PM)

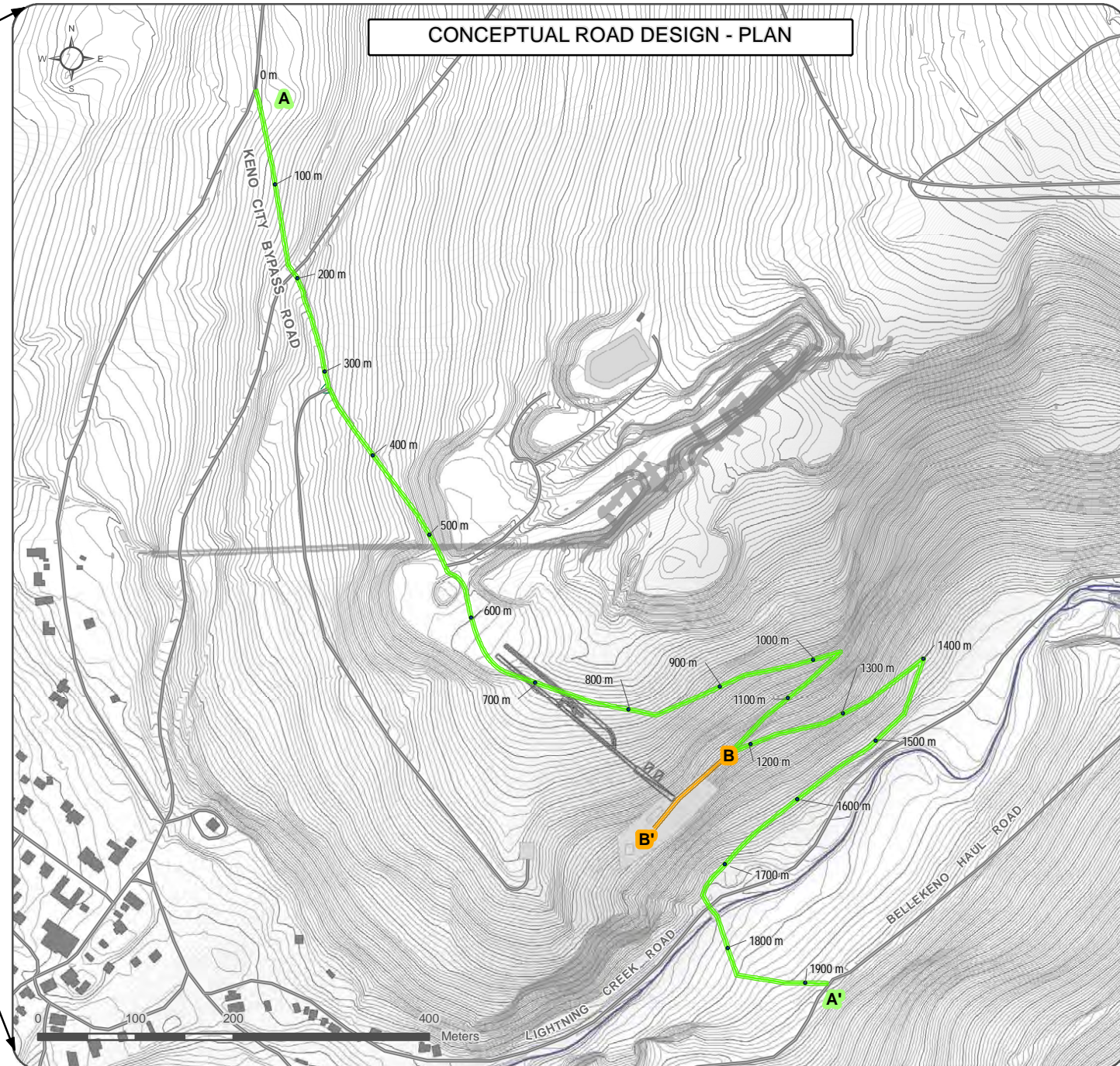
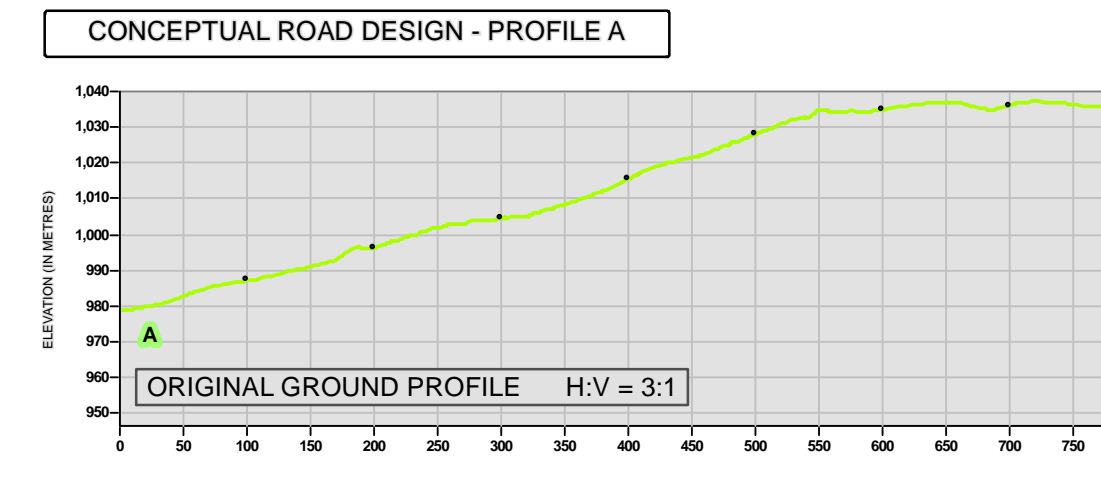
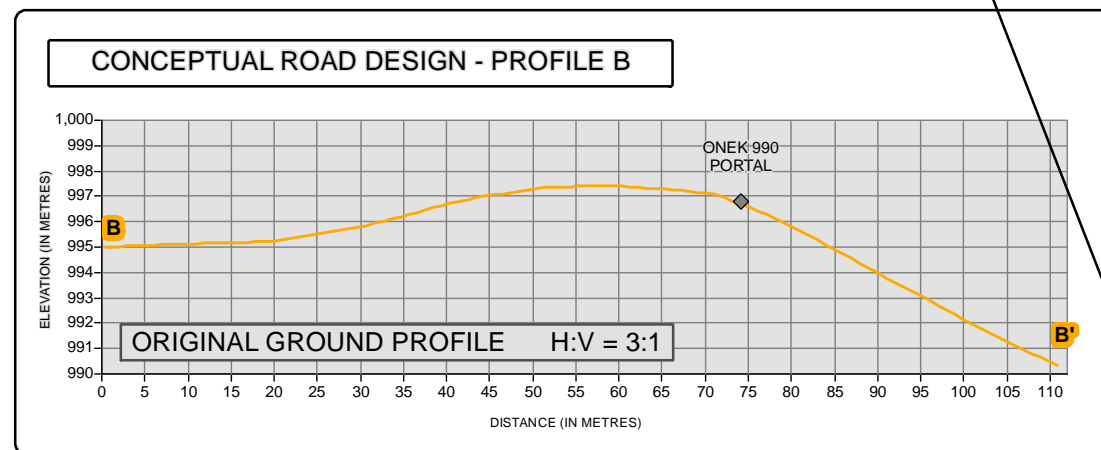
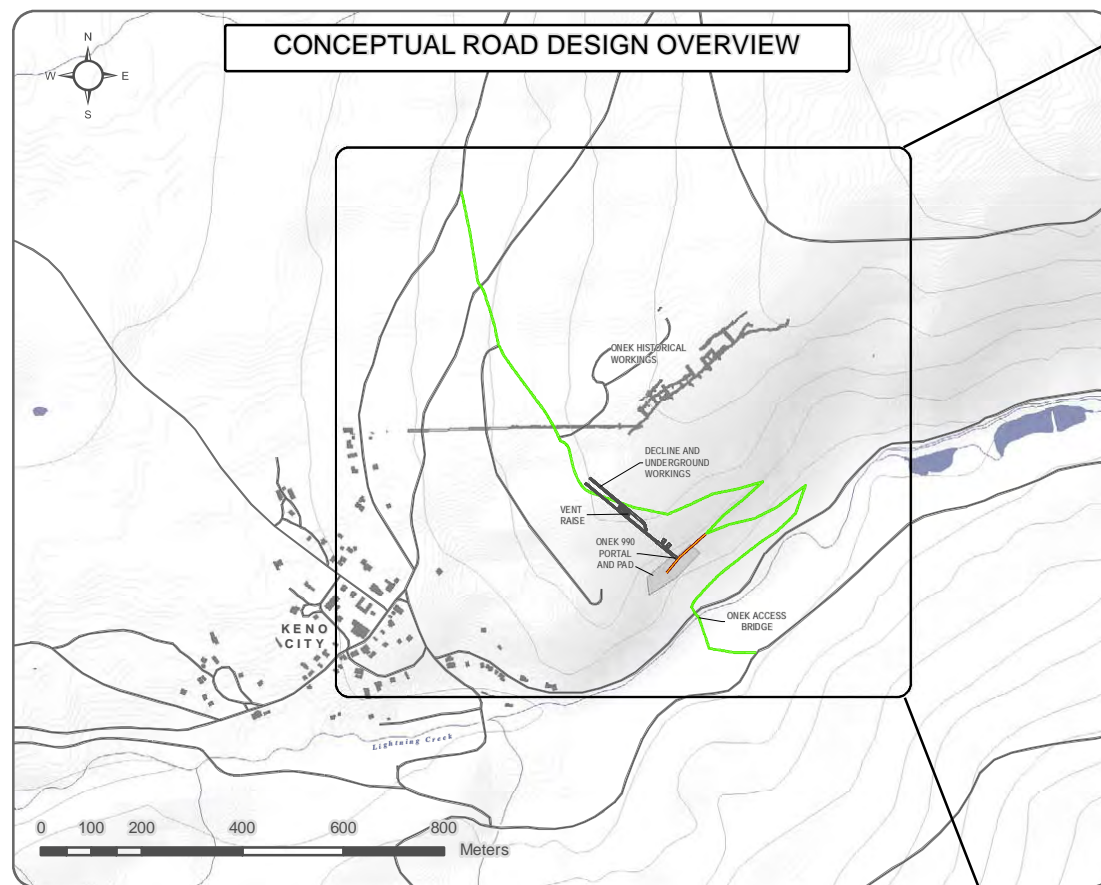

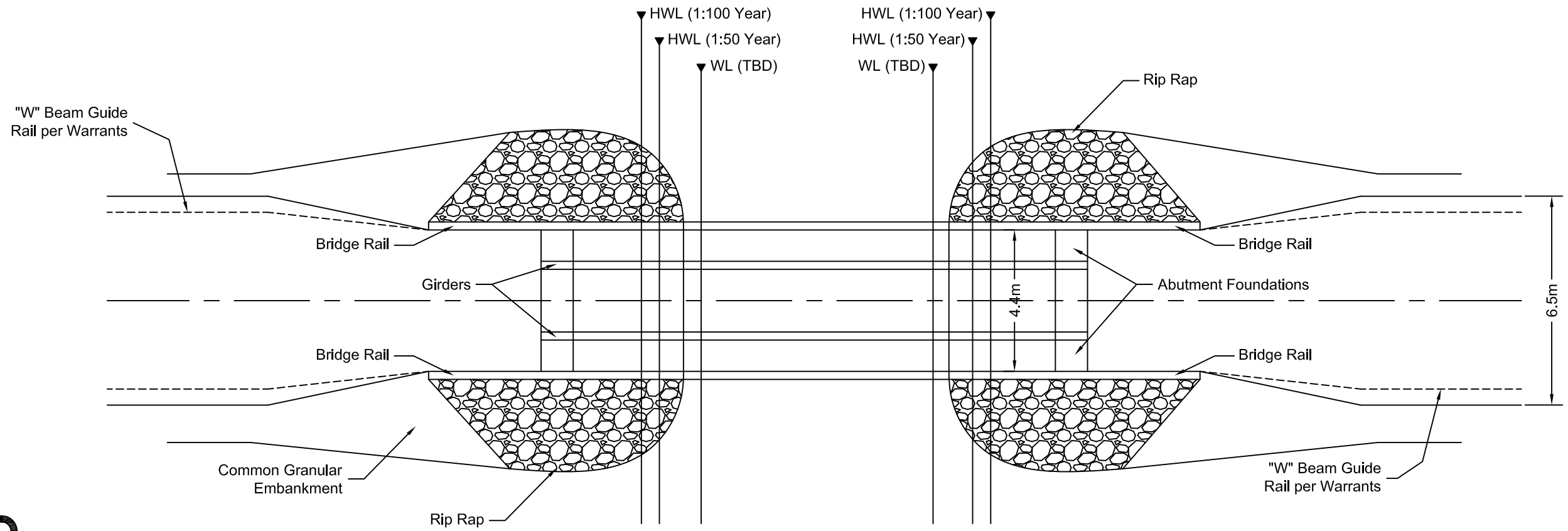

**NOT FOR CONSTRUCTION**

**Notes:**

1. Bridge elevation, length and abutment positions to be determined by contributing drainage area calculations to a 1:100 year flood event. Governing criteria for the height of the bottom of the bridge girders (lowest Obstacle over the stream) was provided by Transport Canada, marine safety who requires that this elevation be at least 1.5m above the 1:100 flood event elevation. (TBD)
2. Rip rap gradation to be confirmed subject to maximum stream velocity calculations at a 1:100 year flood event.
3. Abutment type and foundation design to be determined subject to geotechnical investigations and recommendations.
4. Silt fencing to be deployed during installation as required.
5. No machine clearing to be employed within 30m of the wetted perimeter (OHWM).
6. Detailed designs will be sealed by a professional engineer registered in the Yukon, and submitted to the appropriate agencies prior to construction.
7. Determine navigable waters protection act applicability first by using "Minor Works and Water User Guide" (Transport Canada).

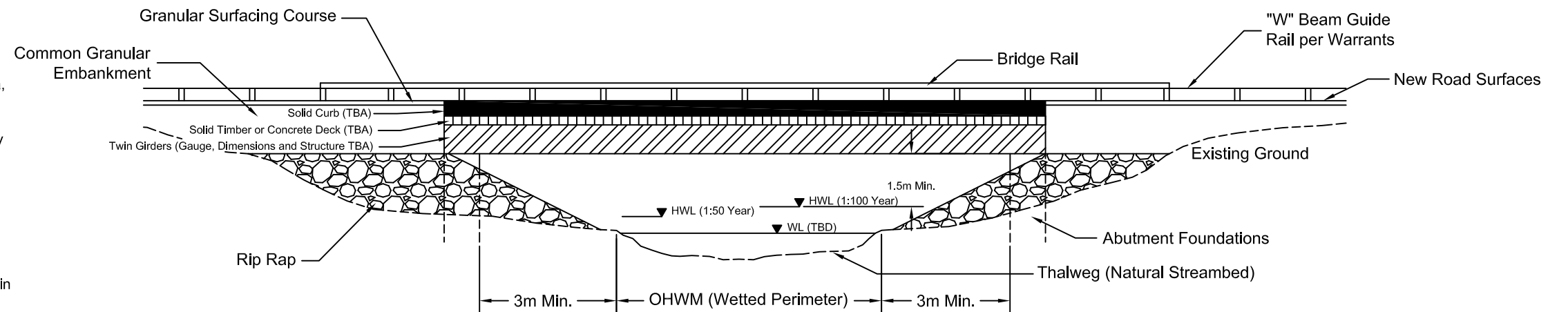

ALEXCO RESOURCE CORP

FIGURE 3



DEPT.	APPROVED BY	DATE	COMMENTS
SURVEY			Based on Y.E.S Conceptual Drawing E10012.DWG
ENGINEERING			
GEOLOGY			
ALEXCO MANAGER			
PROCON SUPER			

TITLE: <b>Typical Conceptual Bridge Design</b>	
Keno Hill Silver District Mining Operations	
Drawn by: D.Silander	Scale: 1:150
Date: June 22, 2012	Approval: Date:
File:	

**NOT FOR CONSTRUCTION**

**Typical Cross-Section  
Access Road**

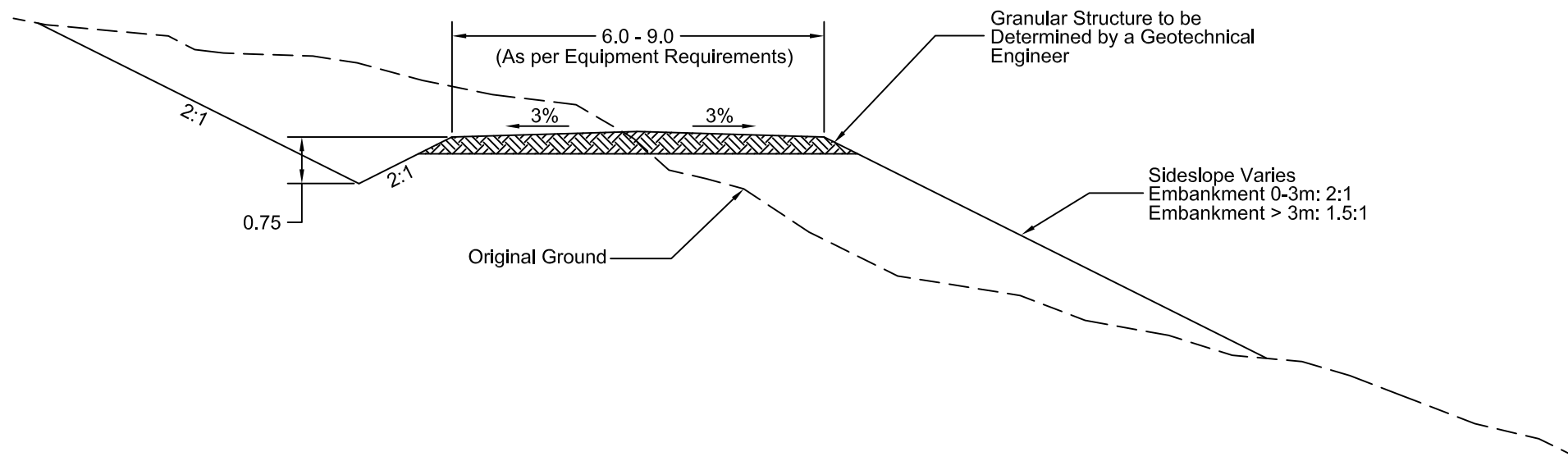

**Typical Cross-Section - Safety Berm  
Haul Road**

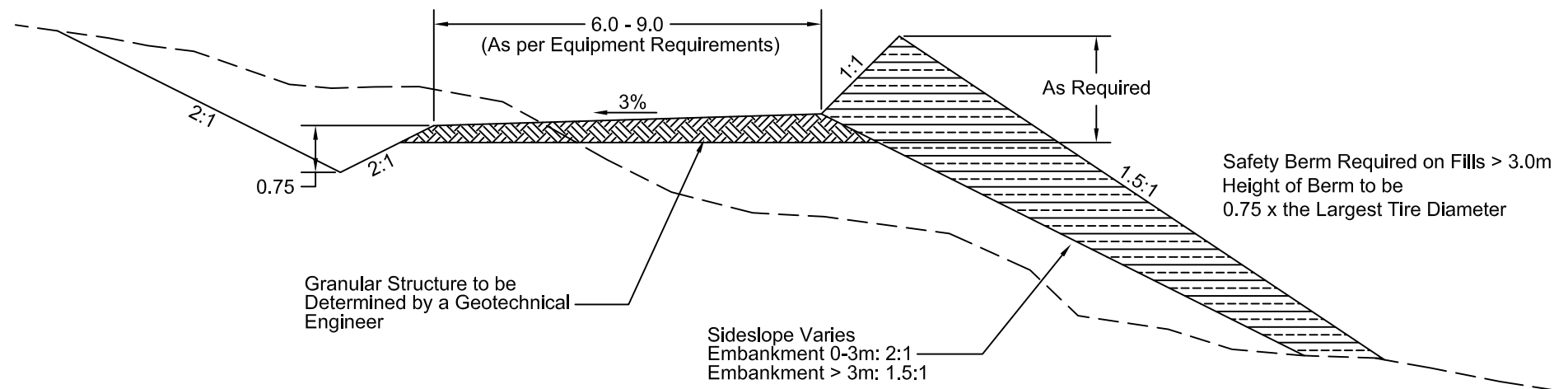

**Notes:**

1. Drawings not for construction.
2. Cut and fill as appropriated to suit topography and soil conditions.
3. Contour interval 2m.
4. See detail for typical bridge installation.
5. Pullouts will be required. Locations to be determined and are dependant on the intervisibilty of pullouts.
6. Safety berms required along length of roadway. Height of berm shall be 3/4 the diameter of the largest vehicle tire.
7. Additional roadwidth required to accommodate safety berm construction.
8. Shown for single lane radio controlled application, for two-way traffic road width will be 3x the width of the largest vehicle.



**ALEXCO RESOURCE CORP**

FIGURE 4

DEPT.	APPROVED BY	DATE	COMMENTS
SURVEY			Based on Y.E.S Conceptual Drawing E10012.DWG
ENGINEERING			
GEOLOGY			
ALEXCO MANAGER			
PROCON SUPER			

TITLE: <b>Typical Conceptual Road Section</b>	
Keno Hill Silver District Mining Operations	
Drawn by: D. Silander	Scale: 1:100
Date: June 23, 2012	Approval: Date:
File:	