



WASTE ROCK MANAGEMENT PLAN

REVISION 5

Original Document: May 2014

Version 5: April 2016

Prepared and Updated for:

ALEXCO KENO HILL MINING CORP.

TABLE OF CONTENTS

1 KENO HILL SILVER DISTRICT MINING OPERATIONS WASTE ROCK MANAGEMENT	1
1.1 INTRODUCTION.....	1
1.2 PURPOSE OF PLAN	1
1.3 SCOPE OF PLAN	1
 2 ROCK CHARACTERIZATION	 3
2.1 SUMMARY OF ROCK CHARACTERIZATION	3
2.2 OVERVIEW OF STUDIES	4
2.2.1 WASTE ROCK FIELD SCREENING CRITERIA	5
2.2.2 P-AML WASTE ROCK GEOCHEMICAL SCREENING CRITERIA	5
2.2.3 ESTIMATED PROPORTIONS OF P-AML AND N-AML ROCK.....	6
 3 ROCK MANAGEMENT	 8
3.1 ROCK EXCAVATION ACTIVITIES.....	9
3.1.1 WASTE ROCK SCREENING	9
3.1.2 FACE SAMPLING METHOD	9
3.1.3 EVALUATION AND WASTE ROCK MANAGEMENT CATEGORY DESIGNATION.....	12
3.2 SURFACE WASTE ROCK FACILITY DESIGN	12
3.2.1 N-AML WASTE ROCK DISPOSAL AREAS.....	12
3.2.2 P-AML WASTE ROCK STORAGE FACILITIES	13
 4 CONFIRMATORY GEOCHEMICAL AND ABA TESTING	 22
4.1 CONFIRMATORY TESTING SAMPLING FREQUENCY AND SCHEDULE	23
4.1.1 ICP SAMPLING FREQUENCY	23
4.1.1.1 ICP FEEDBACK SAMPLING FOR FIELD SCREENING METHODS.....	23
4.1.2 ABA SAMPLING FREQUENCY.....	23
4.1.3 TIME LAG	25
4.1.3.1 TIME LAG BETWEEN EXCAVATION AND SAMPLING	25
4.1.3.2 TIME LAG BETWEEN EXCAVATION AND RECEIPT OF ANALYTICAL DATA.....	25
4.1.3.3 TIME LAG BETWEEN EXCAVATION AND RECEIPT OF ICP DATA.....	25
4.1.3.4 TIME LAG BETWEEN EXCAVATION AND RECEIPT OF ABA DATA	25
4.1.3.5 ABA ANALYSES	26
 5 WASTE ROCK MONITORING.....	 27

5.1 PHYSICAL INSPECTION METHODS	27
5.2 KINECT TESTING OF WASTE ROCK	28
5.2.1 KINECT TESTING OF N-AML WASTE ROCK	28
5.2.2 KINECT TESTING OF P-AML WASTE ROCK	29
6 ADAPTIVE MANAGEMENT.....	30
7 REPORTING	31
8 CLOSURE AND RECLAMATION	32
9 REFERENCES	33

LIST OF TABLES

Table 1: Proportion of Samples Filtered as P-AML in Bellekeno Waste Rock Drillhole Database	6
Table 2: Proportion of Samples Filtered as P-AML in Onek 990 Waste Rock Drillhole Database.....	6
Table 3: Proportion of Samples Filtered as P-AML in Lucky Queen Rock Drillhole Database.....	7
Table 4: Proportion of Samples Filtered as P-AML in Flame & Moth Area of Proposed Permanent Excavation	7
Table 5: Waste Rock Management Categories and Handling.....	8

LIST OF FIGURES

Figure 1: Keno Hill Development Waste Rock Characterization Studies – Components and Key Results.....	3
Figure 2 Face Sampling Method	10
Figure 3 Example of Face Sampling Form	11
Figure 4 Bellekeno East P-AML Site Plan	14
Figure 5 Bellekeno East P-AML Profile, Cross Section and Detail.....	15
Figure 6 Lucky Queen P-AML Site Plan and Cross Section.....	16
Figure 7 Lucky Queen P-AML Site Details and Notes.....	17
Figure 8 Flame and Moth P-AML Site Plan	18
Figure 9 Flame and Moth P-AML Location 1 Cross Sections.....	19
Figure 10 Flame and Moth P-AML Location 2 Cross Sections.....	20
Figure 11 Flame and Moth P-AML Site Details and Notes.....	21
Figure 12 Face Photo of Bellekeno 625 Bypass Showing Sampling According to Lithology and Calculated Sample Areas	22
Figure 13 Waste Rock Sampling Schedule	24

APPENDICES

APPENDIX A - REVIEW OF LUCKY QUEEN WASTE ROCK MANAGEMENT CRITERIA – KENO HILL DISTRICT

**APPENDIX B - REVIEW OF NET ACID GENERATION AND METAL LEACHING CONTROLLING AND CORRELATING FACTORS -
KENO HILL SILVER DISTRICT**

**APPENDIX C – TYPICAL WASTE CONTAINMENT FACILITY DESIGN, KENO HILL SILVER DISTRICT, YT, CONSTRUCTION
SPECIFICATIONS, ISSUED FOR USE**

1 KENO HILL SILVER DISTRICT MINING OPERATIONS WASTE ROCK MANAGEMENT

1.1 INTRODUCTION

The Bellekeno Advanced Underground Exploration and Development Program, assessed under YESAB project number 2008-0039, presented a comprehensive Waste Rock Management Plan (WRMP) for the estimated 248,000 tonnes of waste rock to be excavated over 5 years. Under Section 23 of Water Licence QZ07-078, a Waste Rock Physical Inspection Plan was submitted. The Bellekeno Waste Rock Management Plan was based on studies by Altura Environmental Consulting (Altura). These studies described the Acid Rock Drainage/Metal Leachate (ARD/ML) controlling and correlating factors district wide (Altura, 2008a) and geoenvironmental characterization of the Bellekeno Zone (Altura 2008b).

Clause 13.6 of QML-0009 states that a maximum of 500,000 tonnes of waste rock are to be removed during the undertaking. This tonnage was to come from the Bellekeno mine, but as part of the amendment to QML-0009, Alexco plans to excavate and place on surface a combined maximum of 500,000 tonnes of waste rock from the Bellekeno, Onek 990, Lucky Queen and Flame & Moth Mines. In order to support use of the Waste Rock Management Plan for Flame & Moth, Access Consulting Group (Access) undertook geochemical characterization studies of the Flame & Moth deposit (Access, 2014). Additionally, the waste rock management criteria for Lucky Queen were reviewed by Access and modifications to its screening criteria are presented here within and the rationale presented as Appendix A.

1.2 PURPOSE OF PLAN

This plan outlines practices for management of waste rock to be excavated from the Bellekeno, Lucky Queen Onek 990, and Flame & Moth deposits. The plan is intended to ensure that appropriate management procedures are followed in order to minimize impacts of waste rock brought to surface on land and water resources. Monitoring following waste rock management activities is intended to assess the effectiveness of the management measures, ensure that adaptive management approaches are implemented and to ensure that appropriate information is obtained by Alexco to assist in closure planning.

1.3 SCOPE OF PLAN

Aspects included in this Plan are:

- Definition of rock categories based on potential for reactivity (specifically, acid generation and/or metal leaching);
- Estimation of quantities of each category to be excavated to surface during Mining operations;
- Operational categorization of excavated rock;
- Geochemical and ABA confirmatory testing;
- Control measures as required to mitigate effects of potential acid generation and/or

metal leaching;

- Monitoring and physical inspection activities for waste rock storage areas;
- Reporting of waste rock management activities;
- Geotechnical design of waste rock storage areas; and
- Kinetic testing of N-AML and P-AML waste rock.

2 ROCK CHARACTERIZATION

2.1 SUMMARY OF ROCK CHARACTERIZATION

Studies conducted throughout the Keno Hill Silver District (KHSD) and specifically within each of the mineralized target zones (Bellekeno, Onek 990, Lucky Queen and Flame & Moth) provide a foundation for correlating and understanding the weathering behavior or ‘geoenvironmental’ tendencies of rock in the KHSD. A summary of these waste rock characterization studies and their components and key results is shown in Figure 1.

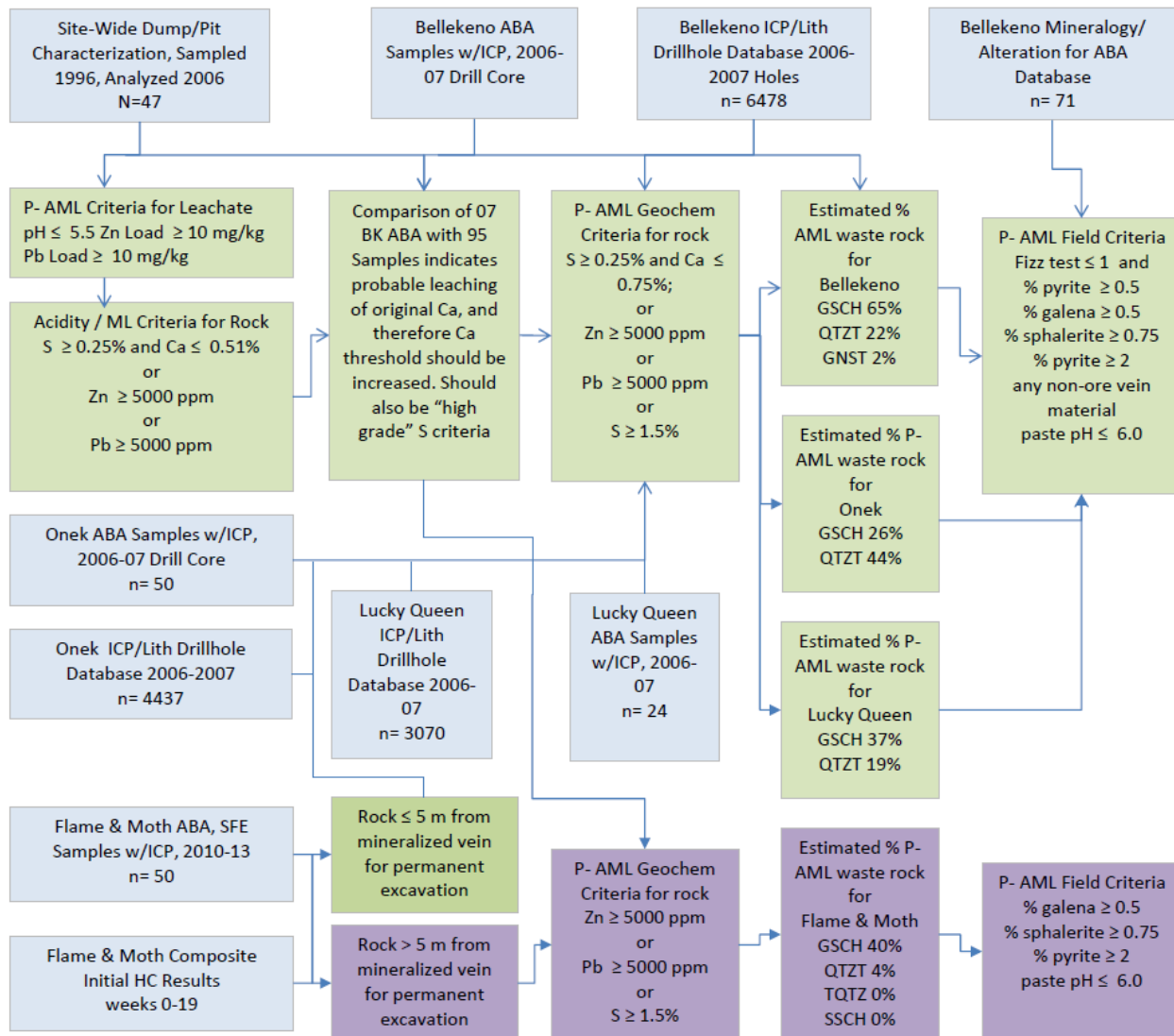

Figure 1: Keno Hill Development Waste Rock Characterization Studies – Components and Key Results

2.2 OVERVIEW OF STUDIES

The geoenvironmental evaluations to support the original Bellekeno Waste Rock Management Plan (WRMP) consisted of data analysis and integration of four specific data components:

- 1) site-wide studies on weathered rock (47 samples);
- 2) acid base accounting of 2006-2007 Bellekeno drill core (71 samples);
- 3) Bellekeno drillhole multi-element and lithology database (6,478 samples), and
- 4) mineralogy and alteration logging data on acid base accounting samples.

In order to support the extension of use of the WRMP for the Onek and Lucky Queen deposits, data analysis of additional data components was undertaken, specifically:

- 1) acid base accounting on 2008-2010 Lucky Queen drill core (24 samples);
- 2) Lucky Queen multi-element and lithology database (3070 samples);
- 3) acid base accounting on 2008-2010 Onek drill core (50 samples); and
- 4) Onek multi-element and lithology database (4437 samples).

In order to support the extension of use of the WRMP for the Flame & Moth deposit, data analysis of additional data components was undertaken, specifically:

- 1) acid base accounting on 2010-2012 Flame & Moth drill core sourced from area of proposed permanent excavation (50 samples);
- 2) multi-element and lithology database 2010-2012 Flame & Moth drill core sourced from area of proposed permanent excavation (50 samples);
- 3) shake flask extraction test results from 2010-2012 Flame & Moth drill core sourced from area of proposed permanent excavation (50 samples);
- 4) humidity cell results (weeks 0-56) of a composite sample created from Flame & Moth drill core sourced from area of proposed permanent excavation.

These studies were used to derive the following components for the Waste Rock Management Plan:

- 1) P-AML geochemical screening criteria for each deposit;
- 2) estimated proportions of P-AML and N-AML material by rock type for the proposed development activities at each of the deposits; and
- 3) field criteria for differentiating P-AML and N-AML rock during excavation activities at each deposit.

2.2.1 Waste Rock Field Screening Criteria

One of the fundamental parts of the Waste Rock Management Plan is field screening of waste rock. Field screening criteria for identifying P-AML at Bellekeno, Onek 990, Lucky Queen and Flame and Moth have been developed as follows:

- a) Slight or no effervescence of pulverized sample with 25% HCl (e.g. presence of none or only a few bubbles, fizz rating ≤ 1), and visual estimated pyrite $>0.5\%$, or;
- b) Any sample with one or more of the following:
 - i. visual estimated sphalerite $\geq 0.75\%$
 - ii. visual estimated galena $\geq 0.5\%$
 - iii. visual estimated pyrite $\geq 2\%$
 - iv. any mineralized vein material associated to the ore vein
 - v. paste pH ≤ 6.0

2.2.2 P-AML Waste Rock Geochemical Screening Criteria

The standard geochemical screening criteria for identification of P-AML rock apply to all rock permanently excavated from the Bellekeno, Onek 990, and Lucky Queen deposits. The standard geochemical criteria are as follows:

- a) Ca% $\leq 0.75\%$ and S via ICP $\geq 0.25\%$;
- b) or S via ICP $\geq 1.5\%$;
- c) or Pb ≥ 5000 ppm;
- d) or Zn ≥ 5000 ppm.

In accordance with ACG 2014, geochemical screening criteria for identification of P-AML rock for the Flame & Moth rock distal to (≥ 5 m or the presence of vein associated stringers, whichever is further) from the mineralized vein fault deposit is as follows:

- b) or S via ICP $\geq 1.5\%$;
- c) or Pb ≥ 5000 ppm;
- d) or Zn ≥ 5000 ppm.

YESAB recommended that AKHM establish a maximum zinc concentration for the use of N-AML waste rock as construction material near surface water. Appendix B, Review of Net Acid Generation and Metal Leaching Controlling factors – Keno Hill Silver District outlines the method for determining the zinc threshold of 1100 ppm zinc for placement of N-AML waste rock within 30 m of a surface water body.

2.2.3 Estimated Proportions of P-AML and N-AML Rock

Applying the geochemical screening criteria to the waste rock drillhole databases for each deposit shows the proportions of P-AML rock estimated for each lithology. Table 1 shows the results for Bellekeno, Table 2 shows the result for Onek 990, and Table 3 shows the results for Lucky Queen.

Table 1: Proportion of Samples Filtered as P-AML in Bellekeno Waste Rock Drillhole Database

Lithology		Number of Samples in Database	Number of Samples Screened as P-AML	Percentage of Samples Screened as P-AML
Description	Code			
Chloritic Schist	CHSCH	222	27	12%
Calcareous Quartzite	CQTZT	505	54	11%
Greenstone	GNST	567	10	2%
Graphitic Schist	GSCH	870	562	65%
Quartzite	QTZT	3293	719	22%
Schist, Undifferentiated	SCH	775	299	39%
Sericitic Schist	SSCH	205	37	18%

Table 2: Proportion of Samples Filtered as P-AML in Onek 990 Waste Rock Drillhole Database

Lithology		Number of Samples	# of P-AML Samples	% of P-AML Samples
Description	Code			
Chloritic Schist	CHSCH	48	7	15%
Calcareous Quartzite	CQTZT	179	29	16%
Greenstone	GNST	193	25	13%
Graphitic Schist	GSCH	472	122	26%
Interbedded Carbonaceous Quartzite and Schist	ICQS	170	66	39%
Quartzite	QTZT	2440	1071	44%
Schist	SCH	136	39	29%
Sericite Schist	SSCH	138	39	28%
Thin Bedded Quartzite	TQTZT	343	189	55%

Note: Lithology units with less than 40 samples not included in calculation (CSCH and PHY)

Table 3: Proportion of Samples Filtered as P-AML in Lucky Queen Rock Drillhole Database

Lithology		Number of Samples	# of P-AML Samples	% of P-AML Samples
Description	Code			
Graphitic Schist	GSCH	399	149	37%
Quartzite	QTZT	2110	391	19%
Thin Bedded Quartzite	TQTZT	279	83	30%

Table 4: Proportion of Samples Filtered as P-AML in Flame & Moth Area of Proposed Permanent Excavation

Lithology		Number of Samples	# of P-AML Samples	% of P-AML Samples
Description	Code			
Graphitic Schist	GSCH	5	2	40%
Quartzite	QZT	28	1	4%
Thin Bedded Quartzite	TQZT	7	0	0%
Sericite Schist	SSCH	6	0	0%
Calcareous Quartzite	CQZT	2	0	0%
Greenstone	GNST	1	0	0%
Calcareous Schist	CSCH	1	0	0%
	Total	50	3	6%

3 ROCK MANAGEMENT

Waste rock excavated from underground operations can be categorized into the following categories:

- **N-AML:** Rock of non-economic grade, expected to be comprised of over 85% Central Quartzite unit (quartzite typically intercalated with minor amounts of schist), and less than 15% Greenstone. As presented in Section 1.2, the majority of the waste rock excavated is expected to be N-AML; rock field-classified as N-AML will be stored in designated locations on site.
- **P-AML: Waste Rock and Mineralized Waste Rock of no Economic Interest:** Rocks field-classified as P-AML (mainly pyrite rich graphitic schist) will be stored in designated P-AML waste rock storage facilities or permanently stored underground as cemented back fill within excavated stopes. In addition to P-AML wall rocks, some vein material especially along the margins of zoned veins contain mostly gangue minerals such as siderite, pyrite and quartz but do not contain economic amounts of Ag, Zn, or Pb minerals and therefore are of no economic interest. Due to their increased likelihood for acidic or metal leaching, all such mineralized non-economic rock is considered to be P-AML and will be stored in P-AML waste rock storage facilities or permanently stored underground as cemented back fill within excavated stopes.
- **Mineralized Rock of Uncertain Economic Interest:** Vein material which contains significant Ag, Zn or Pb minerals but is not obviously economic may be temporarily stockpiled at the mine site or mill site on lined contained pads. Confirmatory assay will determine whether this rock is milled, or is sent to the P-AML waste rock storage facility or hauled back underground.

Table 5 summarizes waste rock management categories and handling. Included for each category are environmental characteristics, use and storage specifications, geochemical criteria, and field screening criteria.

Table 5: Waste Rock Management Categories and Handling

	P-AML Waste Rock	N-AML Waste Rock	Mineralized Rock
Environmental Characteristics	Potentially acid-generating and/or metal leaching	Non- acid-generating and non-metal leaching	Ag, Pb, and Zn grades of economic interest. May contain minerals with potential for net acidity and/or metal leaching
Uses and Storage	Not suitable for general construction purposes To be stored permanently within lined P-AML WRSFs Some material may be removed from P-AML WRSFs and returned fur underground backfill at closure	May be used for general construction purposes	May be stockpiled temporarily at the portal sites or mill, then either milled or sent to P-AML waste rock storage facility

3.1 ROCK EXCAVATION ACTIVITIES

3.1.1 Waste Rock Screening

Samples for both field screening and compositing for further geochemical and ABA confirmatory testwork are collected using the Face Sampling Method, which is used in all new mine working developments. This method ensures accurate, representative characterization of each blast round and allows field screening tests to be performed in a timely manner so that waste rock can be most efficiently treated according to the waste rock management categories (Table 4).

3.1.2 Face Sampling Method

The Face Sampling Method (Figure 2) has been developed into the following procedure:

- First, the site geologist marks up the heading and center line of the development drive. The geologist demarks the side walls and back heights to be taken, then assesses the rock face by spray painting the boundaries between each lithology and paints the sample number of each lithology on the face. Next, the geologist makes a pencil sketch and takes a photograph of the face.
- The geologist then samples each lithology and visually estimates each lithology/sample for sulphide and carbonate content and records the data on the Face Sampling Form (see Figure 3).
- After being collected, the samples then are taken to a geology field laboratory (typically located near the mine portal) where they are dried using a convection dryer, then crushed and pulverized by a geologist or lab technician and stored until needed for compositing.
- The Face Sampling Form is completed and the waste rock management category is determined based on the field screening criteria, Section 2.2.2.

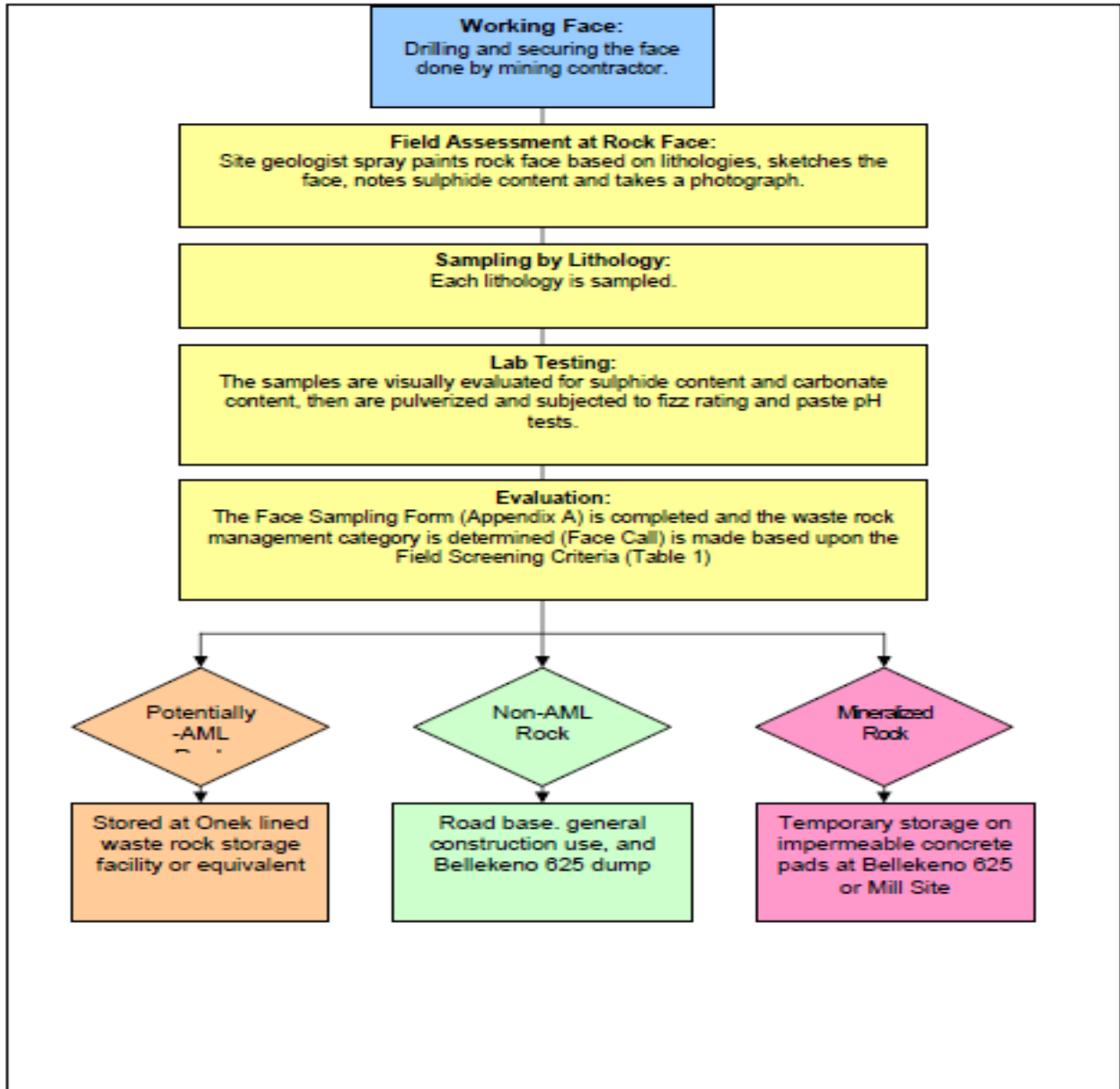

Figure 2 Face Sampling Method

**ALEXCO RESOURCE CORP. KENO HILL PROJECT
 FACE SAMPLING FORM**

Mine: BK 625 Geologist: T.M / M.W. Date: 28-Oct-08

Development: SW B-PASS 625 Production: Waste Sample Type: CHIP

Face Location	Spad #	Dist. (m)	Direction	Face Dimensions	Width (m)	Height (m)	Length (m)
	<u>P27</u>	<u>7.3m</u>	<u>SW</u>		<u>2.4</u>	<u>2.4</u>	

Face Name: P27-SW-7.3m

Sample#	Primary Lithology	Lab Testing		Visual Estimate					Area(m ²)
		Paste pH	Fizz Rating	%Pyrite	%Sphal.	%Galena	%CaCO3		
<u>E607498</u>	<u>COZET</u>	<u>9.65</u>	<u>4</u>	<u>0</u>	<u>0</u>	<u>0</u>	<u>70.75</u>	<u>2.48</u>	
<u>499</u>	<u>GSCH 5% COZET 50%</u>	<u>9.11</u>	<u>4</u>	<u>0.25</u>	<u>0</u>	<u>0</u>	<u>70.75</u>	<u>0.80</u>	
<u>500</u>	<u>COZET</u>	<u>9.56</u>	<u>4</u>	<u>0</u>	<u>0</u>	<u>0</u>	<u>70.75</u>	<u>3.04</u>	

Notes: FAULT ON L.H.S. SINISTRAL OFFSET - 0.35 m. 15cm THICK GORGE ALONG FAULT. MUCK AS ROAD BASE
COZET units both have strongly developed jointsets w/ mod-heavy limonite staining. No visible Py on freshly broken COZET. Minor Py in GSCH band.

ABA Classification:
 # 1

Figure 3 Example of Face Sampling Form

3.1.3 Evaluation and Waste Rock Management Category Designation

The results of all screening criteria are evaluated according to the criteria presented in Sections 2.2.1 & 2.2.2, and the entire round is designated to the appropriate waste rock management category (more commonly referred to as the “face call” or ABA classification, with 1 being N-AML, 2 being P-AML). A special case may occur when a given blast round contains a complex mixture of lithologies including both N-AML and P-AML units. If overall less than 30% of the working face is deemed as P-AML, and the remainder of the face consists of rock with a high neutralization potential (such as calcareous quartzite), the geologist may assign the entire blast round as N-AML. The rationale here is that upon blasting and transport, the rocks from all units are mixed and the small portion of P-AML rocks would be overwhelmed by the net neutralizing potential N-AML units, and bulk chemistry of the round would be N-AML. As an example, consider the following 240 tonne blast round which contains 30% graphitic schist (1.75% S, 1% Ca) intercalated with 70% calcareous quartzite (0.25% S, 2.8% Ca). This is an extreme example, as 1.75% sulfur is well above the 95th percentile for graphite schist analyses presented in the Altura 2008b. In contrast, Ca = 2.8% for the calcareous quartzite is the average value of calcareous quartzite samples from analyses used in Altura 2008b. Thus, upon blasting and transport the 240-tonne muck pile of mixed lithology has a bulk chemical composition of the following:

For Sulfur	$1.75\% \times 0.3$	For Ca	$1\% \times 0.3$
	<u>$+0.25\% \times 0.7$</u>		<u>$+2.8\% \times 0.7$</u>
	0.7%		2.26%

The bulk composition of this blast round falls well within the N-AML criteria of having $S \leq 1.5\%$ and $Ca \geq 0.75\%$. Translating the geochemical data into the more industry standard NP:MPA ratio using the relationship derived Altura 2008b, $NP = 25.76[\%Ca] + 7.537$ and $MPA = \%S \times 31.25$. Using these relationships, the preceding example would have a NP:MPA ratio of 3.0, which is higher than the 2:1 ratio which is indicated by MEND (2009) to be unlikely to produce net acidity.

Some discretionary decisions on the part of the geologist are necessary; for example, in a case of 20% of the working face comprised of a highly sulphidic zone in an otherwise benign working face, the geologist may opt to designate the entire round as P-AML due to the high concentration of P-AML potential in a small zone. It is also important to note that this scenario in which the blast face contains up to 30% P-AML rock is relatively uncommon, and in all cases, testing and determination is made on a conservative basis, meaning that the site geologist will only allow these P-AML containing blast rounds to be classified as N-AML if the remainder of the blast face is determined to have ample neutralization potential.

3.2 SURFACE WASTE ROCK FACILITY DESIGN

3.2.1 N-AML Waste Rock Disposal Areas

To date, Alexco has utilized all N-AML waste rock produced from any of its operations and underground development within the District for site construction purposes (e.g. road construction, laydown areas, general construction of site infrastructure) and has not constructed any dedicated WRDAs within the District. Alexco

did submit geotechnical design for a N-AML WRDA (EBA, 2010) to be constructed along the north flank of Sourdough Hill for excavation at the Bellekeno Mine; however, the requirements for construction material resulted in this WRDA no longer being required.

Should construction of additional N-AML WRDAs be required, Alexco will submit Issued for Use designs for review and approval prior to construction. For example, the existing waste rock pile at the Lucky Queen site may be extended to accommodate N-AML material from the Lucky Queen mine (EBA, 2011).

3.2.2 P-AML Waste Rock Storage Facilities

Surface storage of P-AML waste rock was proposed for the Bellekeno, Onek 990, Lucky Queen and Flame and Moth Mines. Alexco relies on an approved EBA design entitled *Typical Waste Containment Facility Design, Keno Hill Silver District, YT* (EBA, 2008) for temporary or permanent surface storage of P-AML waste rock within the Keno Hill District, which forms Appendix C. Prior to construction of new P-AML Waste Rock Storage Facilities (WRSFs), Alexco will submit Issued for Use designs for review and approval prior to construction. The designs within Appendix form the design basis for the Onek P-AML WRSF, which construction has not been completed.

The site plan, profile, cross section and detail of the proposed Bellekeno P-AML WRSF is shown in Figures 4 and 5. Further details regarding the Bellekeno P-AML WRSF can be found in the Issued for Use EBA (2009) report.

The site plan, profile, cross section and detail of the proposed Lucky Queen P-AML WRSF is shown in Figure 6 and 7. Further details regarding the Lucky Queen P-AML WRSF can be found in the Issued for Use EBA (2012) report.

The site plan, profile, cross section and detail of the proposed Flame and Moth P-AML WRSF is shown in Figure 8 to Figure 11. Further details regarding the Flame and Moth P-AML WRSF can be found in the Issued for Use EBA (2014) report.

O:\keno\W14101142 Onek Waste Containment Facility - Design\001 - Bellekeno P-AML Waste Facility\Bellekeno East P-AML Facility\20090727.dwg [FIGURE 1] July 30, 2009 - 2:12:57 pm (BY: CHRIS DIXON)

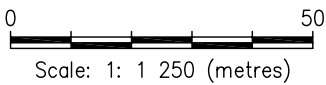
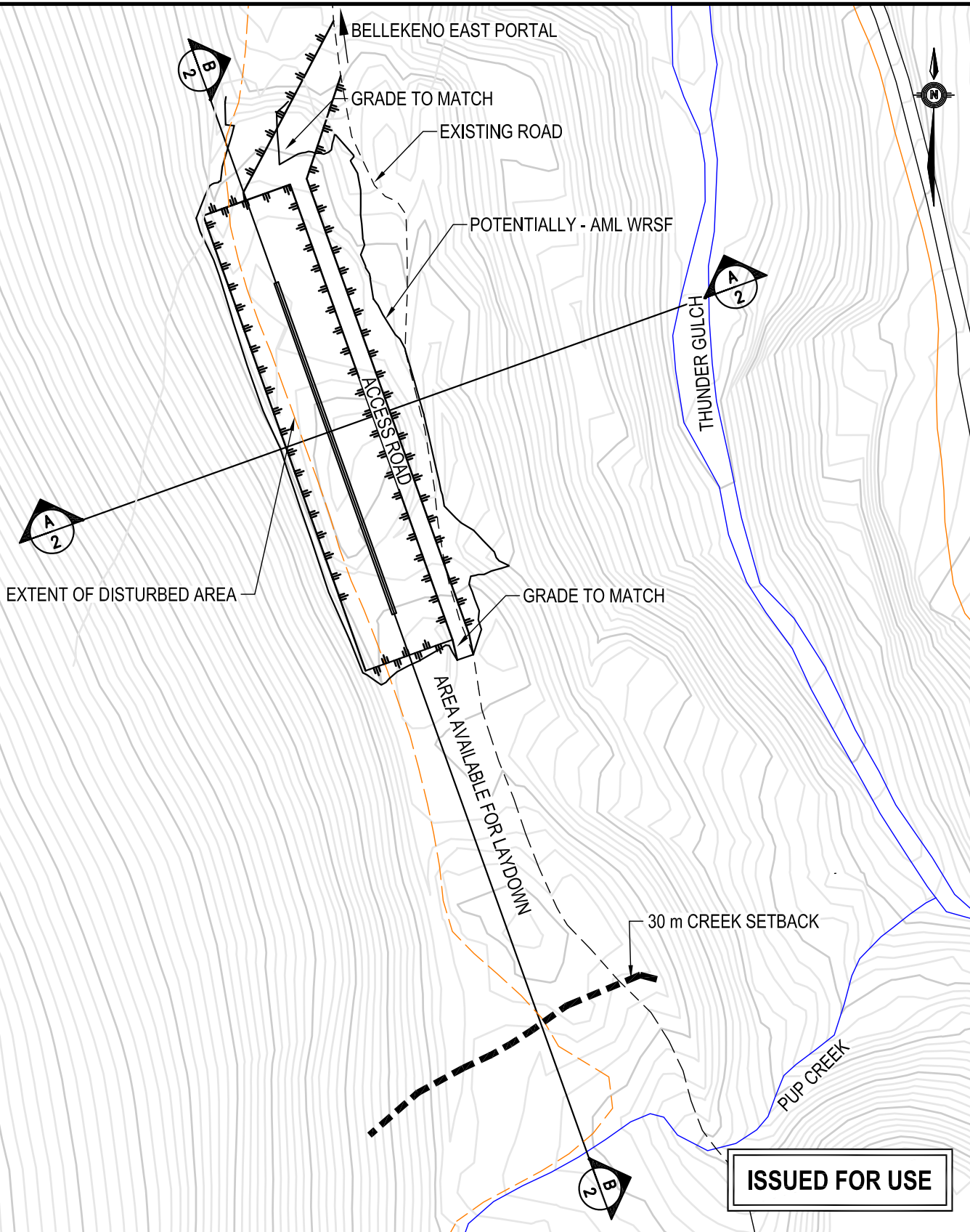

CLIENT



EBA Engineering Consultants Ltd.

**TEMPORARY WASTE CONTAINMENT FACILITY
BELLEKENO EAST SITE**

**BELLEKENO EAST P-AML SITE
SITE PLAN**

PROJECT NO. W14101142.001	DWN KJT	CKD CJD	REV 0
OFFICE EBA-WHSE	DATE July 30, 2009		

Figure 4

O:\Keno\W14101142 Onek Waste Containment Facility - Design\001 - Bellekeno P-AML Waste Facility\Bellekeno East P-AML Facility-20090727.dwg [FIGURE 2] July 30, 2009 - 2:12:22 pm (BY: CHRIS DIXON)

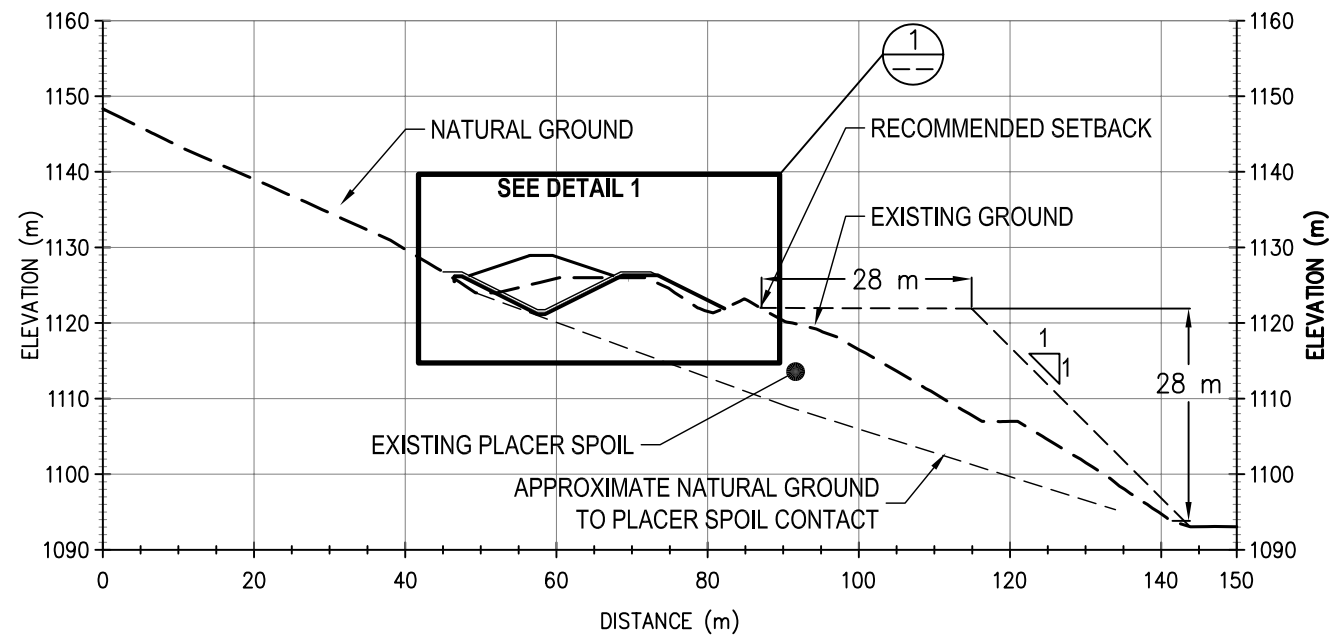

CROSS-SECTION **A**
SCALE: 1 : 1000 **1**

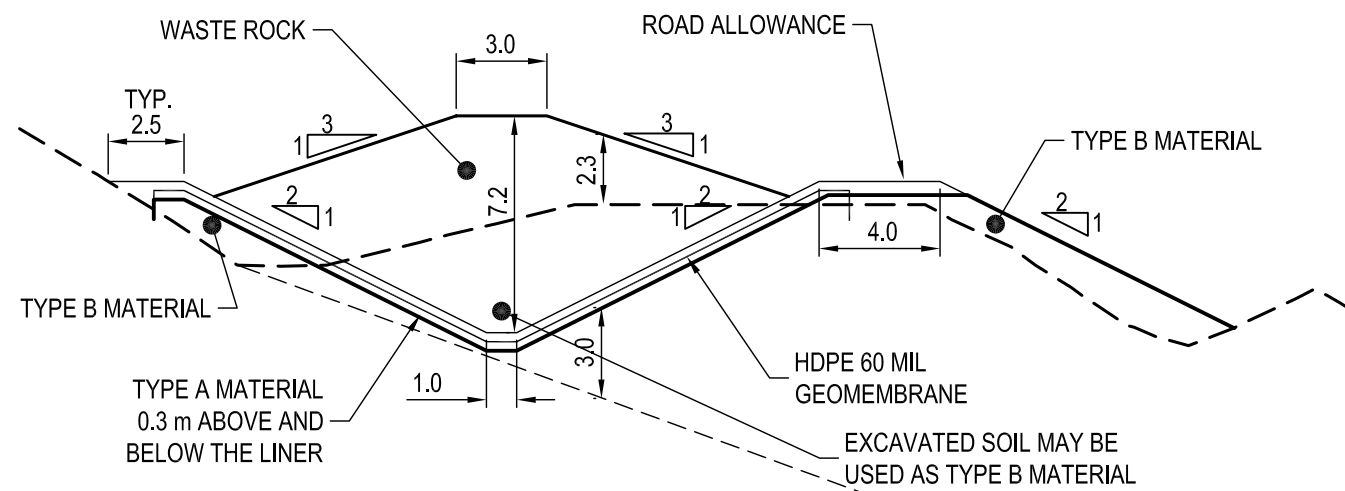

DETAIL **1**
SCALE: 1 : 250 **1**

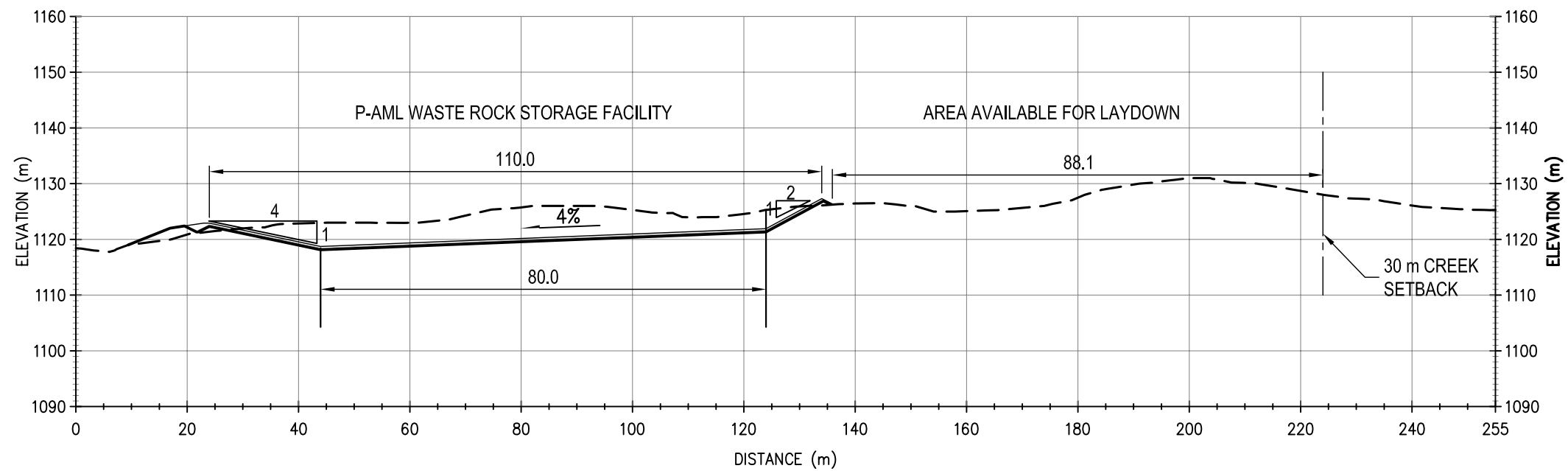

PROFILE **B**
SCALE: 1 : 1000 **1**

ISSUED FOR USE

LEGEND

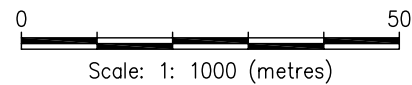

CLIENT



EBA Engineering Consultants Ltd.



**BELLEKENO EAST P-AML WASTE ROCK STORAGE
KENO CITY, YUKON**

PROFILE, SECTION AND DETAIL

PROJECT NO. W14101142.001	DWN KJT	CKD CJD	REV 0
OFFICE WHSE	DATE July 27, 2009		

Figure 5

Q:\Whitehorse\Drawings\Kenos\W14103113-01 Lucky Queen Waste Storage Facility Design\W14103113-01 Fig. 1_R0.dwg [FIGURE 1] December 21, 2012 - 5:12:37 pm (BY: BUCHAN, CAMERON)

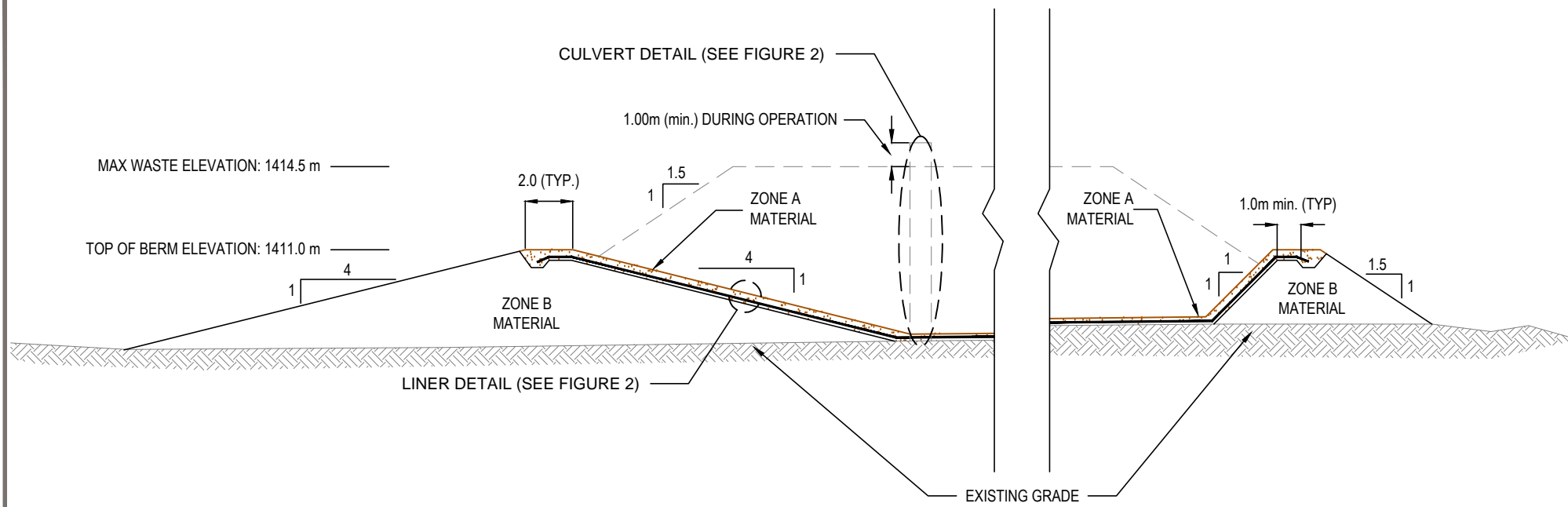

SECTION A - A'
Scale: 1: 250 (metres)

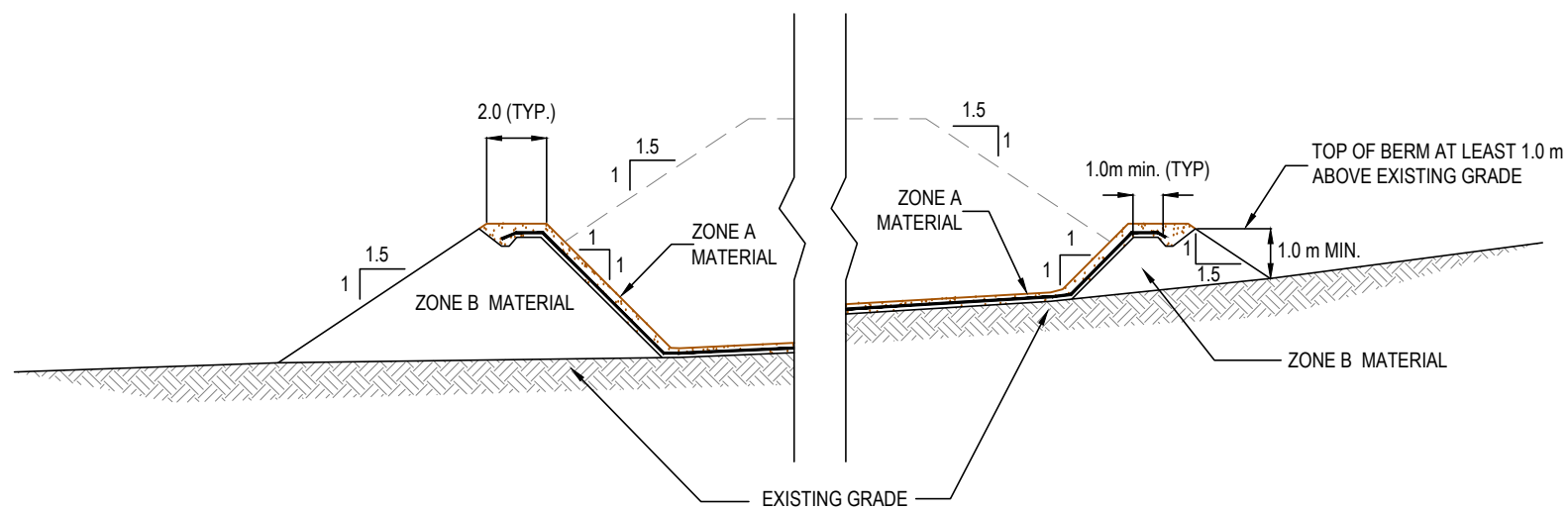

SECTION B - B'
Scale: 1: 250 (metres)

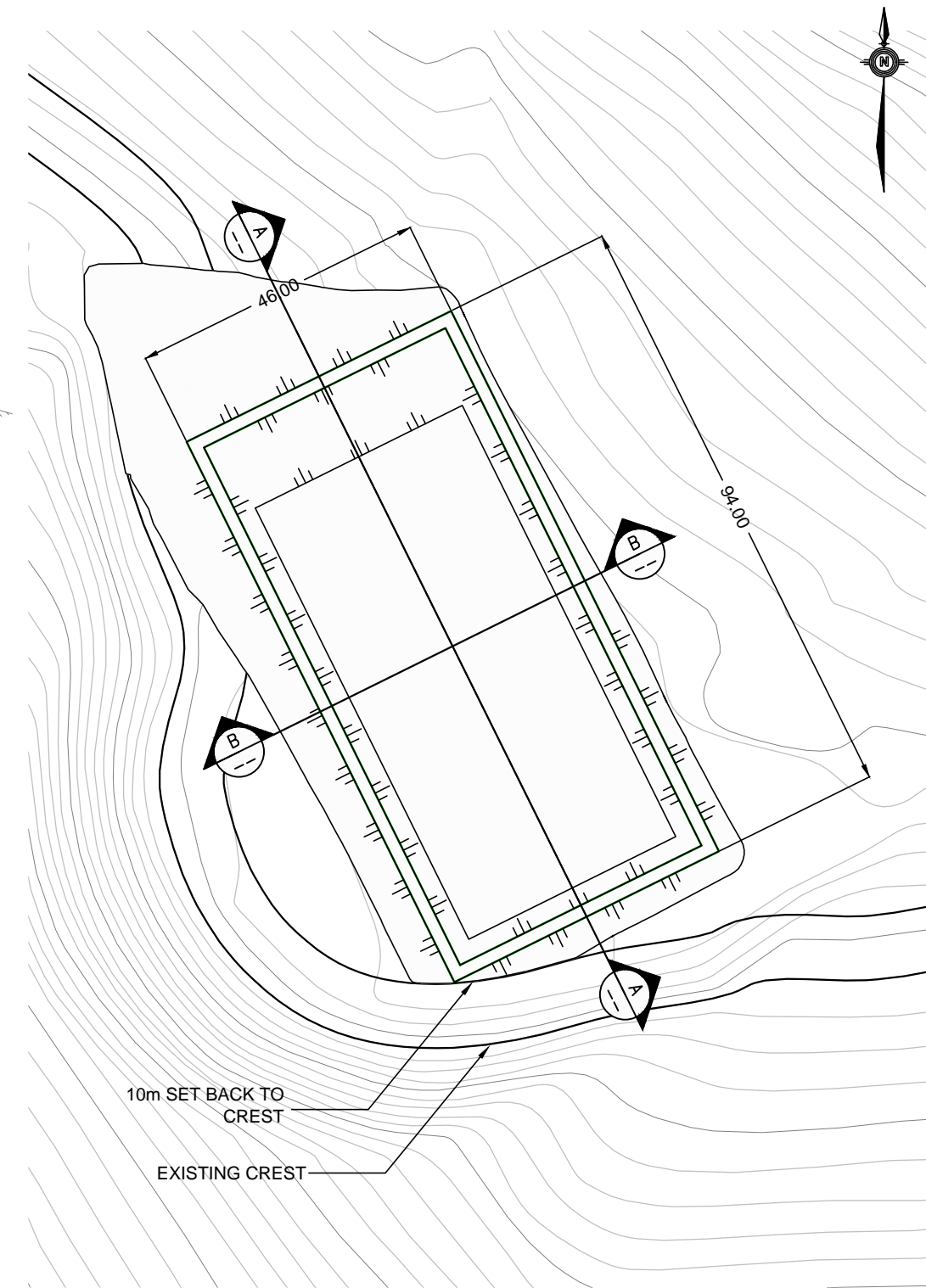

PLAN VIEW
Scale: 1: 1000 (metres)

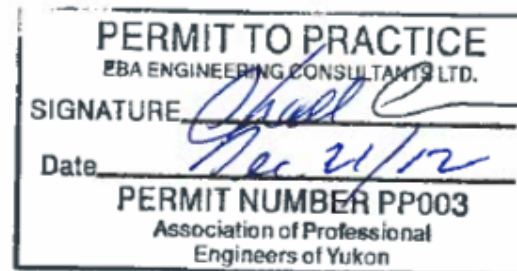
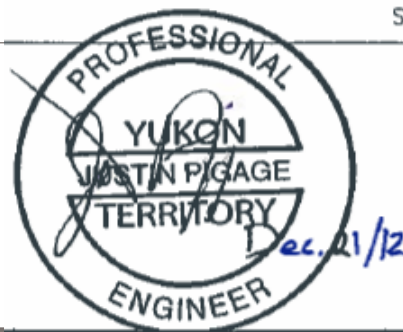

STATUS
PRELIMINARY - NOT FOR CONSTRUCTION

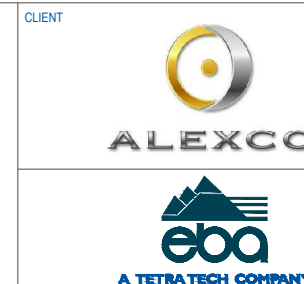

LUCKY QUEEN WASTE STORAGE FACILITY KENO HILL DISTRICT, YUKON				
PLAN AND SECTIONS				
PROJECT NO. W14103113-01	DWN CB	CKD JTP	REV 0	Figure 6
OFFICE EBA-WHSE	DATE December 21, 2012			

Q:\Whitehorse\Drawings\Keno\W14103113-01 Lucky Queen Waste Storage Facility Design\W14103113-01 Fig_2_R0.dwg FIGURE 2] December 21, 2012 - 5:13:35 pm (BY: BUCHAN, CAMERON)

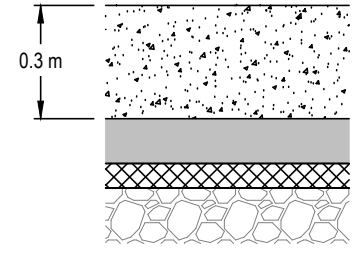

DETAIL 2 - FACILITY FLOOR AND BERMS

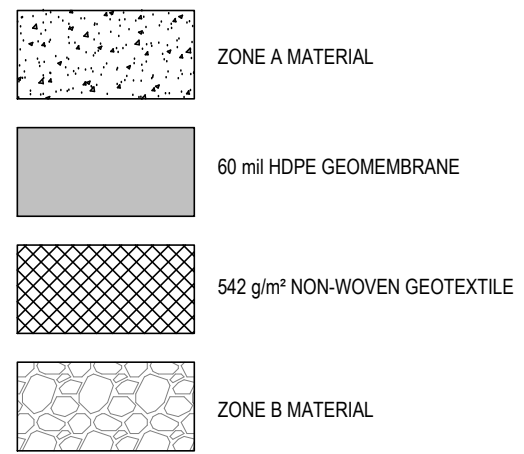

LINER SYSTEM DETAIL KEY

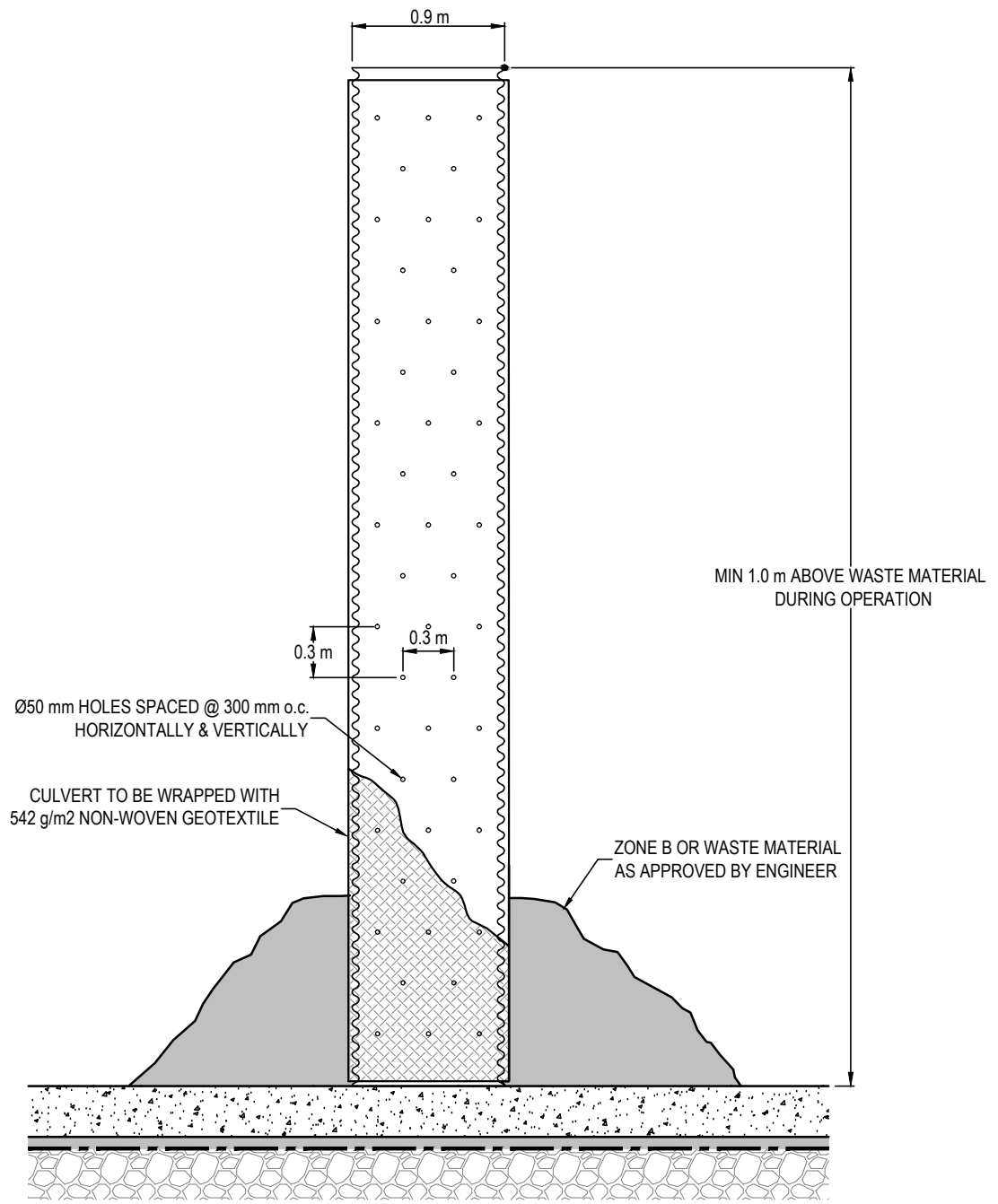

DETAIL 1 - VERTICAL SUMP CULVERT

NOTES :

These specifications, relevant to construction of the Lucky Queen Waste Storage Facility, have been extracted from the Typical Waste Containment Facility Design Construction Specifications, Keno Hill Silver District, YT (EBA July 2008).

The Lucky Queen Waste Storage Facility shall be constructed to the specifications below and the dimensions indicated on the Construction Drawings.

Water in the facility will flow towards and pond in the vertical culvert where it will be monitored and tested on a regular basis. Based on water quality analysis, the waste water will be extracted via pump truck and discharged to the environment or treated in a designated treatment facility.

The facility has been sized based on containment of approximately 17,222 m³ of waste, when the ultimate capacity is reached a 0.5 m soil cover will be placed over the entire facility.

The Zone A material shall consist of hard, durable particles, shall be free of roots, topsoil, and deleterious material and shall have a particle size distribution, as measured by ASTM C136, as presented in Table 1, or as approved by the Engineer.

The Zone B material shall consist of hard, durable particles, shall be free of roots, topsoil, and deleterious material and shall have a particle size distribution, as measured by ASTM C136, as presented in Table 1, or as approved by the Engineer.

The fill materials shall be placed in lifts not exceeding 0.5 m in uncompacted thickness and compacted to at least 95% of maximum dry density using standard effort as per ASTM D698.

The non-woven geotextile shall be 542 g/m² Layfield LP16 or equivalent approved by the Engineer.

The HDPE geomembrane shall be 1.6 mm (60 mil) thick Layfield HDPE 60 or equivalent approved by the Engineer.

The HDPE geomembrane seams shall be welded by a suitably qualified contractor. Trial seams shall be conducted prior to start-up each day and at approximately 4-hour intervals during seaming operations. During the trial seam, the minimum strength criteria set by the manufacturer for the geomembrane should be met.

No construction equipment shall be allowed to travel on the liner prior to the placement of the protective Zone A cover material.

Table 1: Particle Size Distribution Limits

Zone B Material		Zone A Material	
Particle Size (mm)	% Passing by Mass	Particle Size (mm)	% Passing by Mass
200	100		
100	85 – 100		
50	65 – 100		
25	40 – 100	10	100
5	20 – 55	5	80 – 100
2	0 – 20	2	55 – 100
		0.63	25 – 65
		0.25	10 – 40
		0.08	2 – 15

STATUS
PRELIMINARY - NOT FOR CONSTRUCTION

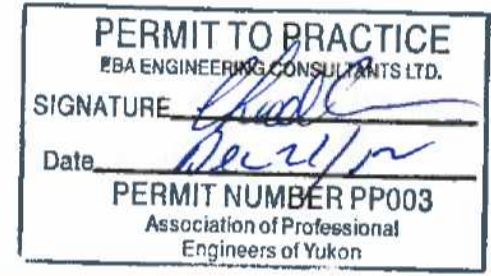

LUCKY QUEEN WASTE STORAGE FACILITY KENO HILL DISTRICT, YUKON				
DETAILS AND NOTES				
PROJECT NO. W14103113-01	DWN CB	CKD JTP	REV 0	Figure 7
OFFICE EBA-WHSE	DATE December 21, 2012			

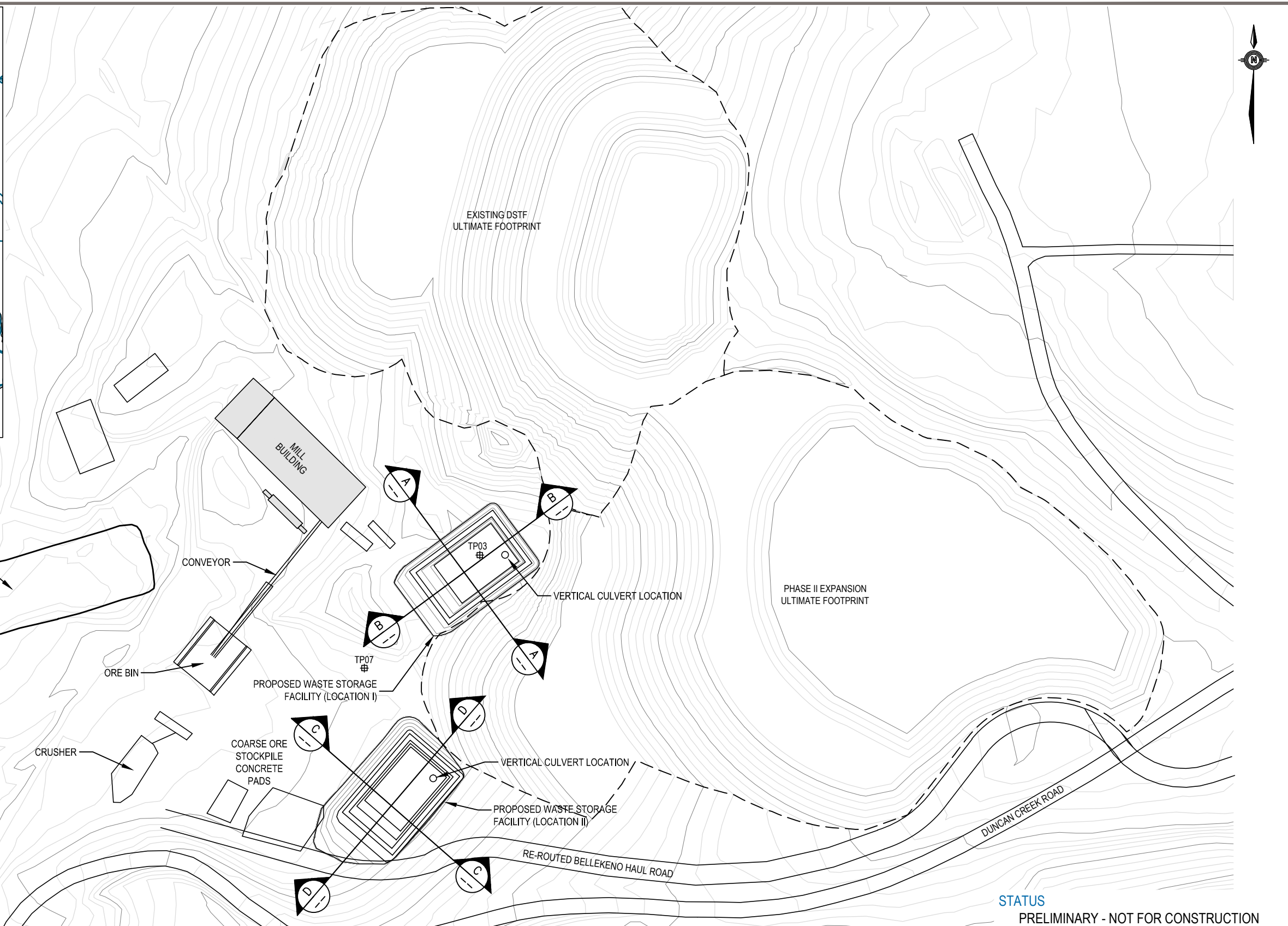
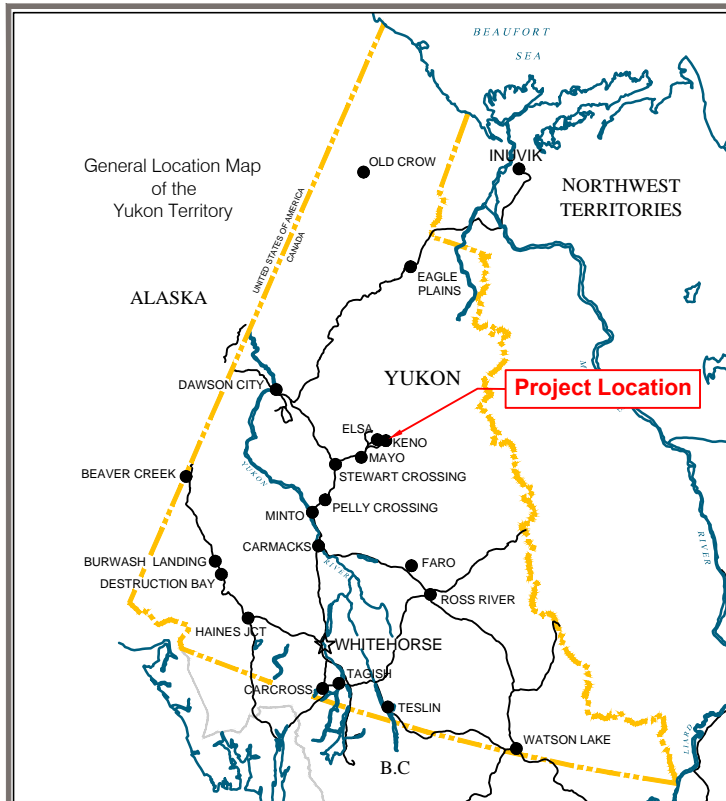

Q:\Whitehorse\Drawings\Keno\W14103485-01 Figs 1-3_R0.dwg [FIGURE 1] October 01, 2014 - 2:19:36 pm (BY: BUCHAN, CAMERON)

LEGEND

⊕ - TESTPIT LOCATION (2009)

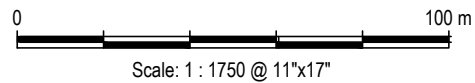

STATUS
PRELIMINARY - NOT FOR CONSTRUCTION

CLIENT



**FLAME AND MOTH WASTE STORAGE FACILITY
KENO HILL DISTRICT, YUKON**

SITE PLAN



PROJECT NO. W14103485-01	DWN CB	CKD JTP	REV 0
OFFICE EBA-WHSE	DATE September 25, 2014		

Figure 8

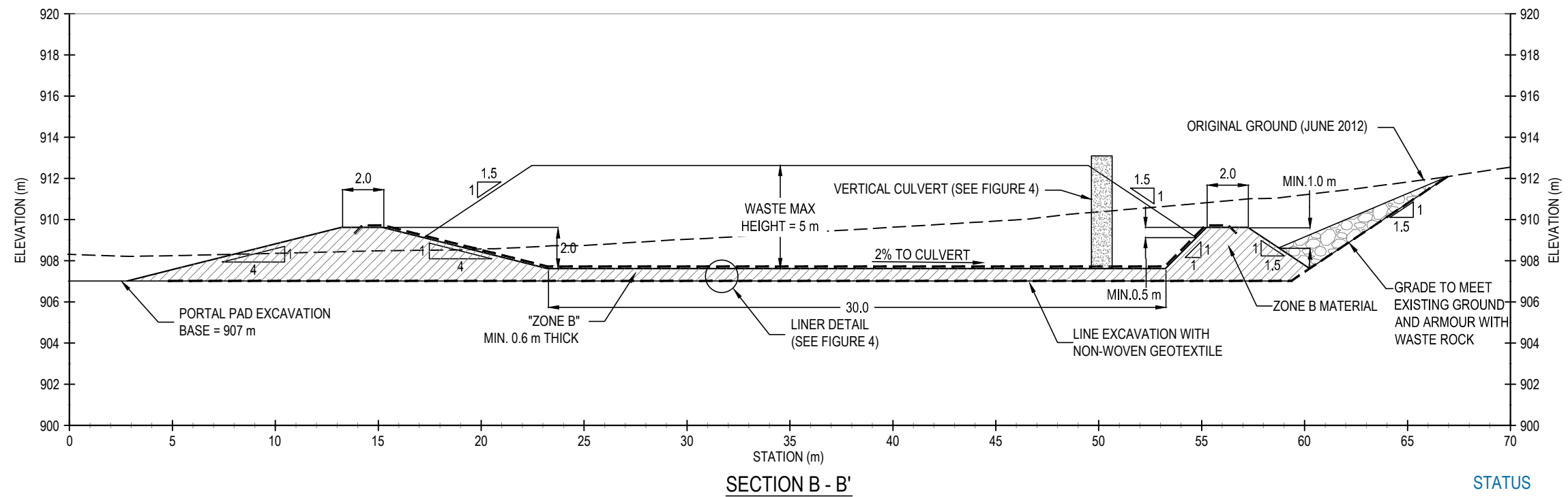
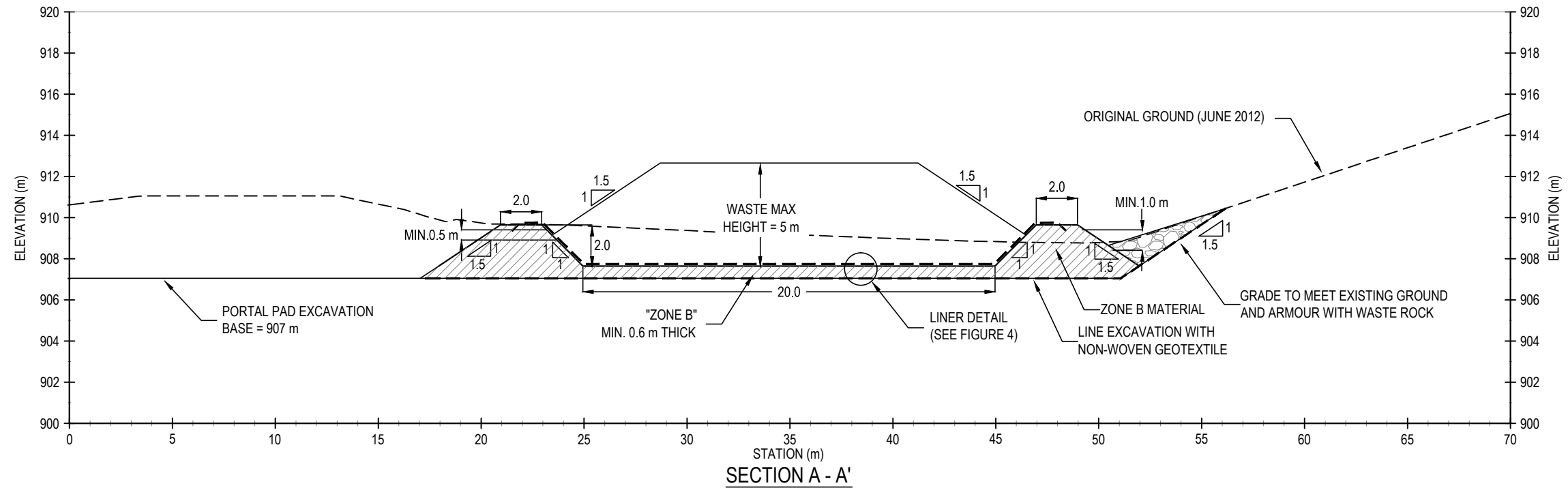

STATUS
PRELIMINARY - NOT FOR CONSTRUCTION

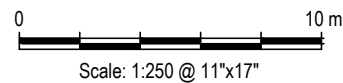

CLIENT



**FLAME AND MOTH WASTE STORAGE FACILITY
KENO HILL DISTRICT, YUKON**

LOCATION | CROSS-SECTIONS



PROJECT NO. W14103485-01	DWN CB	CKD JTP	REV 0
OFFICE EBA-WHSE	DATE September 25, 2014		

Figure 9

Q:\Whitehorse\Drawings\Keno\14103485-01 Flame & Moth P-AML_Design\W14103485-01 Figs 1-3_R0.dwg [FIGURE 2] October 01, 2014 - 2:20:40 pm (BY: BUCHAN, CAMERON)

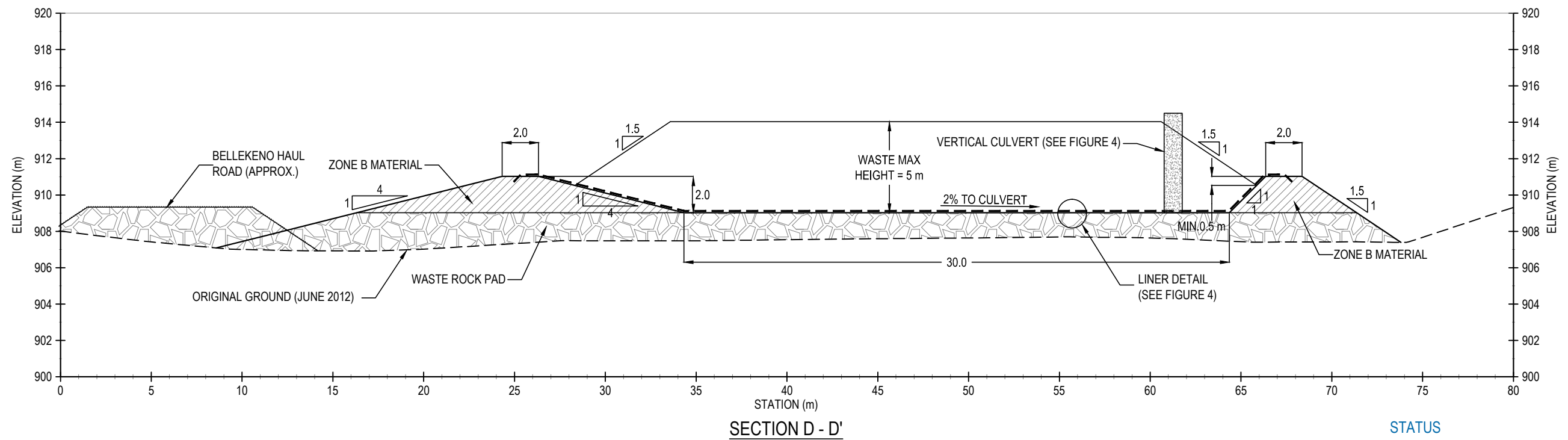
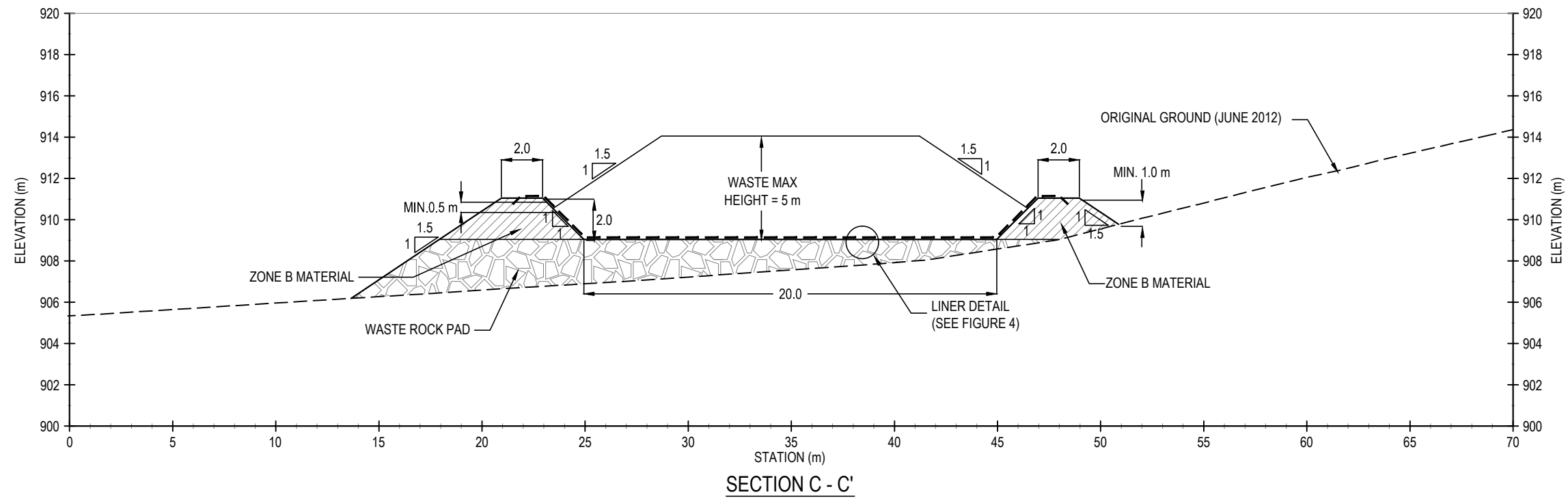

STATUS
PRELIMINARY - NOT FOR CONSTRUCTION

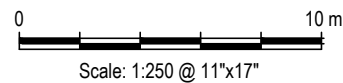

CLIENT



**FLAME AND MOTH WASTE STORAGE FACILITY
KENO HILL DISTRICT, YUKON**

LOCATION II CROSS-SECTIONS



PROJECT NO. W14103485-01	DWN CB	CKD JTP	REV 0
OFFICE EBA-WHSE	DATE September 25, 2014		

Figure 10

Q:\Whitehorse\Drawings\Keno\14103485-01 Flame & Moth P-AML Design\W14103485-01 Figs 1-3_R0.dwg [FIGURE 3] October 01, 2014 - 2:21:44 pm [BY: BUCHAN, CAMERON]

Q:\Whitehorse\Drawings\Keno\W14103485-01_Fig.3_R0.dwg [FIGURE 3] September 30, 2014 - 3:02:12 pm BY: BUCHAN, CAMERON

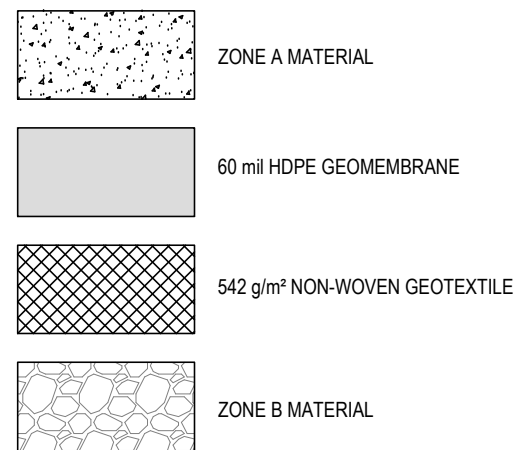
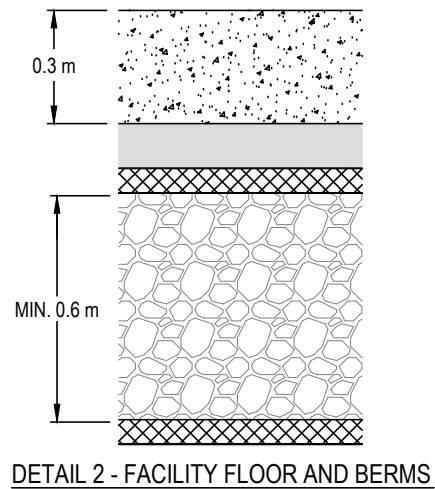
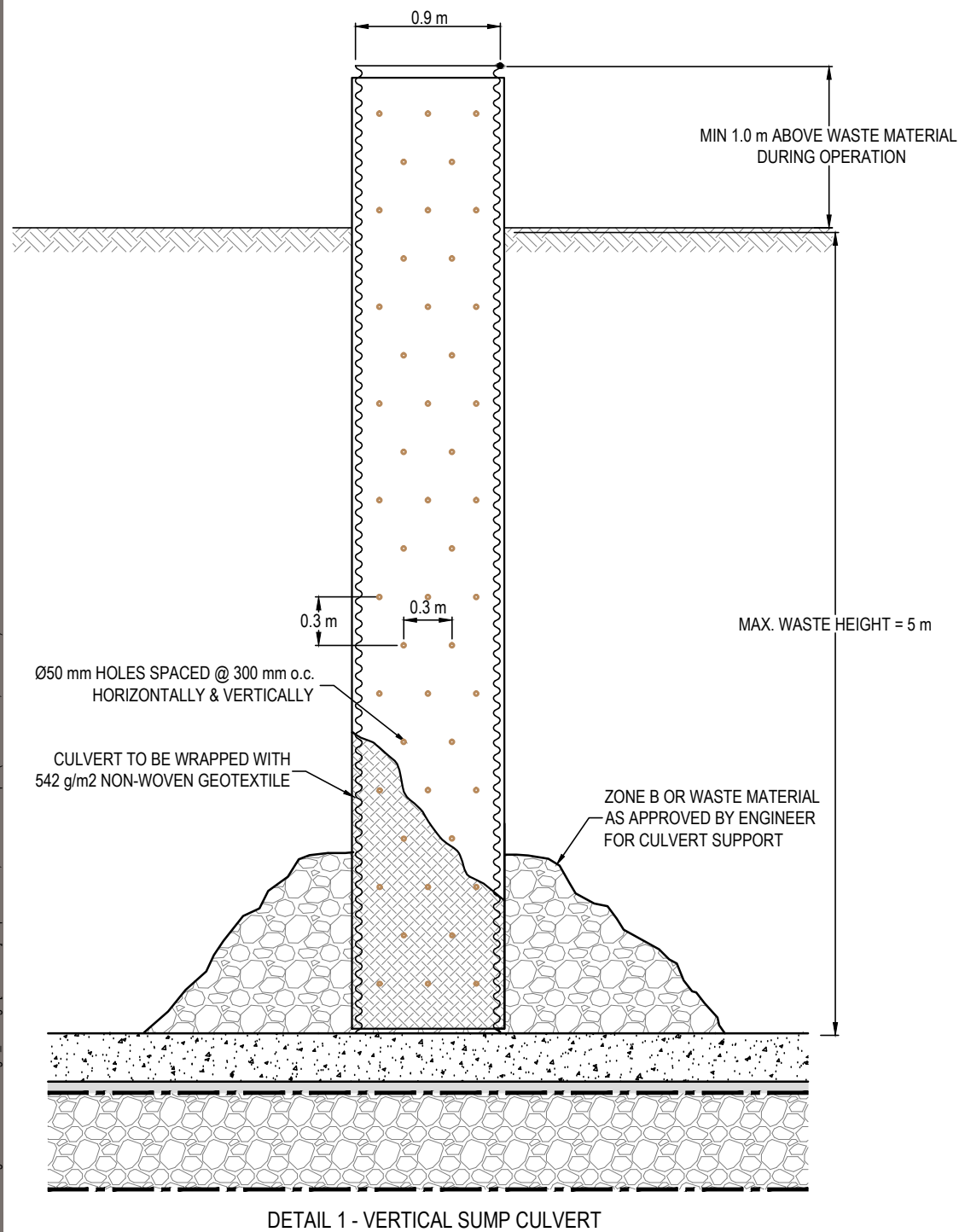

LINER SYSTEM DETAIL KEY

NOTES :

These specifications, relevant to construction of the Flame & Moth Waste Storage Facility, have been extracted from the Typical Waste Containment Facility Design Construction Specifications, Keno Hill Silver District, YT (EBA July 2008).

The Flame & Moth Waste Storage Facility shall be constructed to the specifications below and the dimensions indicated on the Construction Drawings.

Water in the facility will flow towards and pond in the vertical culvert where it will be monitored and tested on a regular basis. Based on water quality analysis, the waste water will be extracted via pump truck and discharged to the environment or treated in a designated treatment facility.

The facility has been sized based on containment of approximately 4,500 m³ of waste, when the ultimate capacity is reached a 0.5 m soil cover will be placed over the entire facility.

The Zone A material shall consist of hard, durable particles, shall be free of roots, topsoil, and deleterious material and shall have a particle size distribution, as measured by ASTM C136, as presented in Table 1, or as approved by the Engineer.

The Zone B material shall consist of hard, durable particles, shall be free of roots, topsoil, and deleterious material and shall have a particle size distribution, as measured by ASTM C136, as presented in Table 1, or as approved by the Engineer.

The fill materials shall be placed in lifts not exceeding 0.5 m in uncompacted thickness and compacted to at least 95% of maximum dry density using standard effort as per ASTM D698.

The non-woven geotextile shall be 542 g/m² Layfield LP16 or equivalent approved by the Engineer.

The HDPE geomembrane shall be 1.6 mm (60 mil) thick Layfield HDPE 60 or equivalent approved by the Engineer.

The HDPE geomembrane seams shall be welded by a suitably qualified contractor. Trial seams shall be conducted prior to start-up each day and at approximately 4-hour intervals during seaming operations. During the trial seam, the minimum strength criteria set by the manufacturer for the geomembrane should be met.

No construction equipment shall be allowed to travel on the liner prior to the placement of the protective Zone A cover material.

Table 1: Particle Size Distribution Limits

Zone B Material		Zone A Material	
Particle Size (mm)	% Passing by Mass	Particle Size (mm)	% Passing by Mass
200	100		
100	85 – 100		
50	65 – 100		
25	40 – 100	10	100
5	20 – 55	5	80 – 100
2	0 – 20	2	55 – 100
		0.63	25 – 65
		0.25	10 – 40
		0.08	2 – 15

STATUS
PRELIMINARY - NOT FOR CONSTRUCTION

NOTE
- THIS PLAN IS NOT TO SCALE

	FLAME AND MOTH WASTE STORAGE FACILITY KENO HILL DISTRICT, YUKON			
	DETAILS AND NOTES			
	PROJECT NO. W14103485-01	DWN CB	CKD JTP	REV 0
	OFFICE EBA-WHSE	DATE September 26, 2014	Figure 11	

4 CONFIRMATORY GEOCHEMICAL AND ABA TESTING

Geochemical and ABA testing of waste rock forms an important component of the waste rock management program. The purpose of this testing is to provide additional verification of the effectiveness of the field screening criteria.

After initial field screening, samples are composited to ensure that they are representative of the blast rounds from which they are taken. First, samples from each face are combined based on their respective tonnages, which are calculated based on their areas on the digitized face photo (see Figure 12). These areas are multiplied by the length of the blast round to produce volumes. The volumes are then multiplied by average density according to their lithology to produce the tonnage represented by each sample. Sample composites are first made of each blast round (face), and are weighted according to their calculated tonnages. Additional compositing is done on these composite blast round samples depending on the analytical method and schedule, which is presented below. Where a number of blast rounds are composited, they are weighted to reflect the tonnage of each respective round.

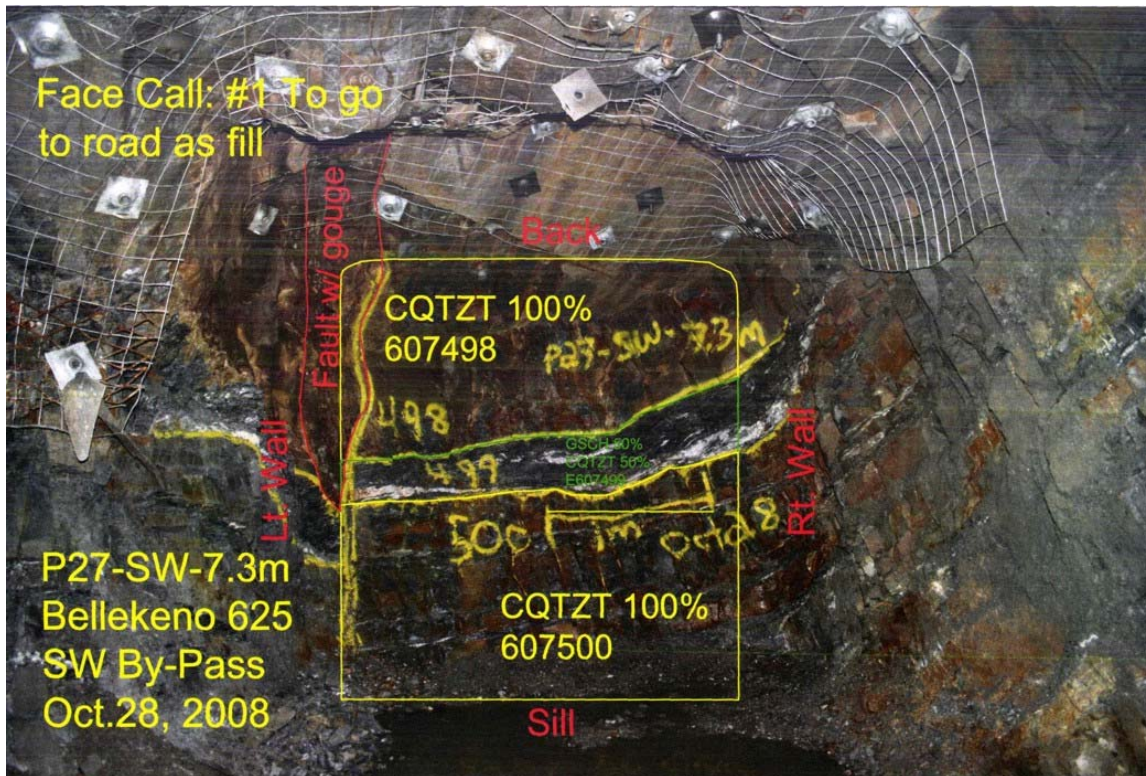

Figure 12 Face Photo of Bellekeno 625 Bypass Showing Sampling According to Lithology and Calculated Sample Areas

4.1 CONFIRMATORY TESTING SAMPLING FREQUENCY AND SCHEDULE

Acid base accounting (ABA) and inductively coupled plasma (ICP) sampling frequencies are done at a minimum of 1 ABA sample (1000 tonnes) per 4,000 tonnes and 1 ICP analysis per 1,000 tonnes in N-AML waste rock. In P-AML waste rock, the sampling density is increased to 1 ABA sample per 500 tonnes and 1 ICP analysis per 500 tonnes.

4.1.1 ICP Sampling Frequency

While meeting per tonnage sampling frequency, the more natural sampling unit is based on number of blast rounds (each represented by a face sample composite). This tonnage depends on several variables including the length of the round, the dimension of the heading, and whether or not there is overblast. Depending on the dimensions of the heading, this typically varies between 3 and 5 blasts per sample.

4.1.1.1 ICP Feedback Sampling for Field Screening Methods

In addition to routine, per tonnage frequency ICP composites described in 4.1, ICP samples will be analyzed for each sample constituting one of the faces in the 1000 tonne ABA composite. These results will be used as a feedback for the Face Sampling Method described in Section 3.1.2. The need for this provision will likely diminish after a reasonable data set is gathered.

4.1.2 ABA Sampling Frequency

Similar to ICP sample composites, ABA sampling will be composited based on the number of blast rounds and in accordance with per tonnage limits in order to be representative of the tonnage as a whole. Due to the ineffectiveness of the larger 10,000 tonne composite for verifying and providing feedback, a smaller and more regular 1000 tonne ABA composite for every 4000 tonnes of excavation was adopted in 2009 and has since been implemented with success. Development and production at Flame & Moth, Bellekeno, Onek and Lucky Queen will involve headings of a variety of sizes (2x2, 3x3 and 4x4 meters) but the general principle of a 1,000 tonne composite ABA sample per 4,000 tonnes will be taken regardless of blast round size.

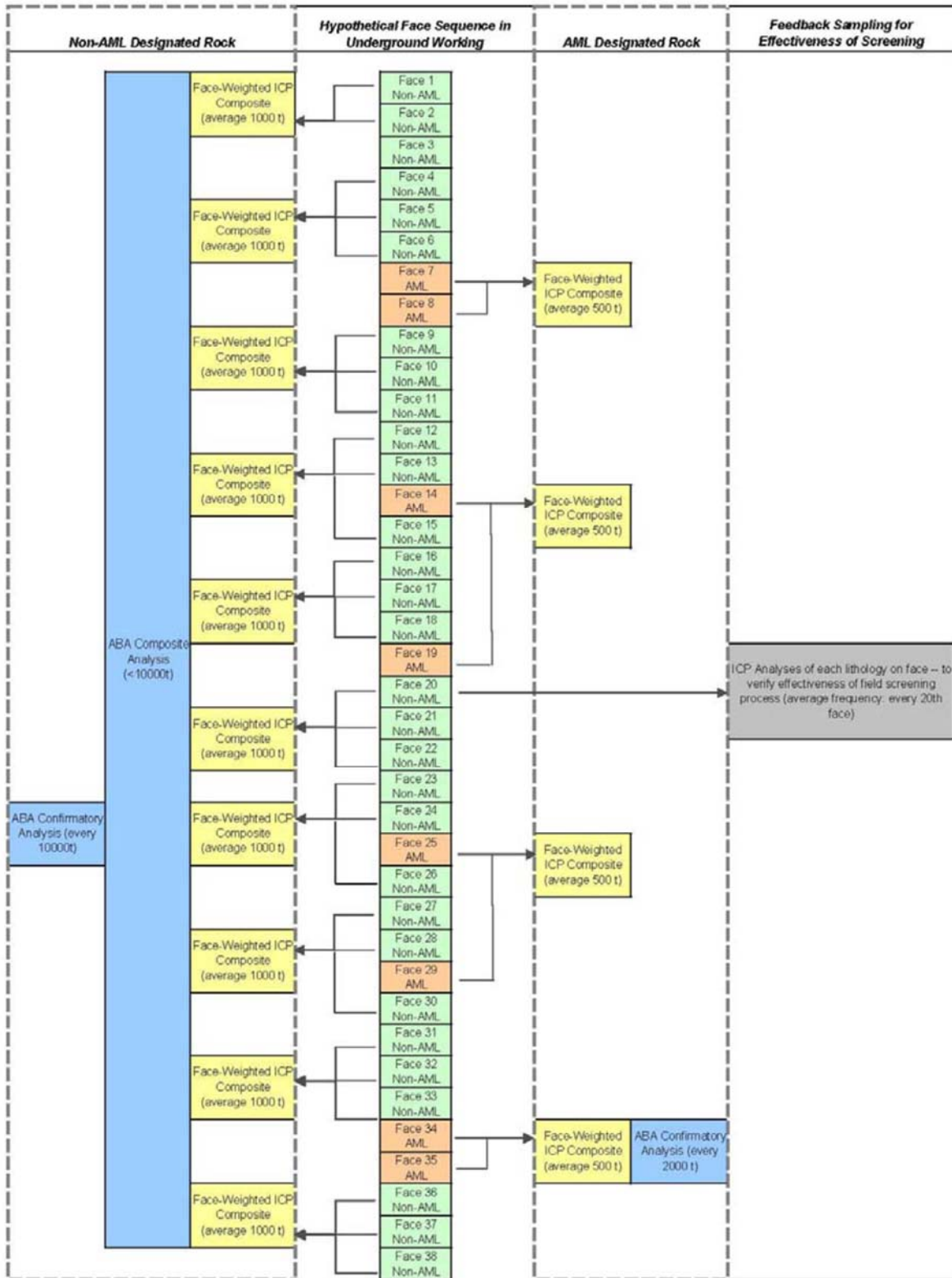

Figure 13 Waste Rock Sampling Schedule

It is important to note that the above criteria, summarised in Figure 13, represent a high sample density. This is in large part driven by the fact that the proposed work is the first rock excavation activity in the district under Alexco's management, and as such it is important to conduct relatively detailed monitoring to develop a sound information base for decision-making and enhancements to future waste rock management strategies. As the understanding increases, such a high sample density will likely no longer be justified.

4.1.3 Time Lag

4.1.3.1 Time Lag between Excavation and Sampling

The time between blasting and exposure of a new face to sampling and the Face Call (waste rock management category designation) for a given round shall not exceed 48 hours notwithstanding unforeseen and extenuating circumstances such as breakdown of analytical or lab equipment.

4.1.3.2 Time Lag between Excavation and Receipt of Analytical Data

The total time between excavation and receipt of analytical data is dependent on a number of factors. First, the size of the composite sample being tested can extend the length of time between excavation and receipt of data especially for individual blast rounds near the beginning of the composite sample. For example, at a rate of development of two blast rounds per week at approximately 120 tonnes per round would take 28 days to accumulate the rock required to complete a composite ABA sample of 1,000 tonnes. In headings of non continuous mining this delay can extend out much further. Second, standard laboratory practices for individual analytical packages take varying amounts of time for completion (e.g. ABA analysis takes longer than ICP). In spite of these uncertainties we are able to suggest the following limits of time lag between excavation and receipt of analytical data for ABA and ICP analysis data.

4.1.3.3 Time Lag between Excavation and Receipt of ICP Data

The time between blasting and exposure of the final face comprising the composite to receipt of ICP analytical data shall not exceed two months notwithstanding extenuating circumstances such as breakdown of lab equipment or delays at the analytical laboratory.

4.1.3.4 Time Lag between Excavation and Receipt of ABA Data

The time between blasting and exposure of the final face comprising the composite to receipt of ABA analytical data shall not exceed three months; notwithstanding extenuating circumstances such as breakdown of lab equipment, or delays at the analytical laboratory.

4.1.3.5 ABA Analyses

Samples submitted for acid base accounting will be pulverized and analysed via modified or Sobek acid base accounting methods, including total sulphur via Leco furnace, sulphate via either sodium carbonate leach or HCl digestion, neutralization potential via modified or Sobek method, total inorganic carbon, and paste pH at a 1:1 solids to water ratio. Siderite correction methods will be used if samples are from within 5 m of the mineralized vein or are suspected to contain siderite.

5 WASTE ROCK MONITORING

Programs for ongoing physical and water quality surveillance of waste rock storage facilities through inspections and drainage monitoring have been established as part of the Advanced Exploration Program. Physical surveillance of waste rock storage areas will occur on a weekly basis at the following locations:

- All P-AML waste rock storage facility or equivalents;
- All N-AML waste rock disposal areas including roads between Bellekeno East Portal and Bellekeno 625, the ‘power line road’ that runs along the north slope of Sourdough Hill, the bypass road constructed along the north side of Keno City, the Bellekeno, Onek 990 and Lucky Queen waste rock disposal areas, and all other locations where N-AML rock is used as fill or construction material.

5.1 PHYSICAL INSPECTION METHODS

The purpose of the physical inspection is to observe and record sufficient information to permit development of a course of action; repair or rehabilitation if it is required. Specifically:

- Physical stability such as settling and excessive erosion (tension cracks, bulges at the toe; on waste rock road surfaces, washouts, rutting and culvert seating);
- Evidence of permafrost degradation in any areas of physical disturbance;
- Evidence of sulphide oxidation (such as snow melt areas, presence of oxidation products); and
- Occurrence of drainage or seeps from rock storage areas. If drainage is noted, flow volume will be estimated and basic field parameters of pH and conductivity recorded as well as sampled for metals. More detailed monitoring will be initiated as required and based on specific results if field monitoring results indicate:
 - i. pH significantly declining between measurements or dropping below 7.0, and/or
 - ii. zinc concentrations show a significant increasing trend or zinc above 0.5 mg/L.

Inspection checklists will be filled out on a weekly basis to ensure structural integrity of mine components and that runoff and discharge is being appropriately managed. The following rating system will be used in the field reporting to evaluate the structural integrity of the areas to be physically inspected:

Excellent	“As New” Condition.
Good	System or element is sound and performing its function; although it shows signs of use and may require some minor repairs, mostly routine.
Fair	System or element is still performing adequately at this time, but needs “priority” and/or “routine” repair to prevent future deterioration and to

restore it to good condition. A fair rating will be reported to site manager after the inspection.

Poor System or element cannot be relied upon to continue to perform its original function without “immediate” and/or “priority” repairs. A poor rating will be reported to site manager after the inspection.

If issues are identified during the weekly inspections of waste rock storage areas, the site manager will be informed immediately and the appropriate mitigative measures will be implemented. An inspection by a qualified geotechnical engineer would be undertaken for physical stability if necessary. Additional erosion and sediment controls may need to be implemented as required. Appropriate mitigative measures will be implemented should acidic or metal rich drainage be detected in order to prevent adverse impacts to receiving waters.

If geotechnical inspections are required, they will be carried out during the summer months when the surface and sides of the various rock-fill structures are not obscured by snow.

The lined P-AML storage pad areas will be monitored for drainage volume with field parameters (pH and conductivity) measured on a monthly basis from May to October. Providing there is sufficient water accumulation, a full suite of water quality analyses will be conducted at least twice per year. The sumps will be monitored monthly using a Heron Instruments Dipper-T probe to determine the accumulation amount of water within the storage facility. Periodically, water will be directed to licenced water treatment and discharge facilities for discharge or treatment prior to discharge if required. Water from any additional P-AML waste rock storage facilities will be treated in the same way. See also the Water Management Plan (Section 6.1). Upon closure, these facilities will be covered with an impermeable liner and will not require ongoing maintenance. See the conceptual closure plan in Section 8 for more details.

5.2 KINECT TESTING OF WASTE ROCK

Clause 93 of QZ09-092 requires that:

93. Within six months of the effective date of this licence, the Licensee shall submit to the Board an updated Waste Rock Management Plan for the Keno Hill Silver District Undertaking which includes kinetic testing of N-AML and P-AML Waste Rock and shall implement that plan.

This section describes kinetic testing to be implemented as part of the WRMP.

5.2.1 Kinect Testing of N-AML Waste Rock

Within 3 months of resumption of commercial production, Alexco commits to initiation of kinetic testing of representative samples of N-AML resulting from excavation of Bellekeno, Lucky Queen, and Onek 990 Mines. This kinetic testing may include the use of laboratory humidity cells, field bins, or field lysimeters. Alexco

commits to conducting kinetic testing on a per-tonnage basis of a minimum of 1 kinetic sample per 40,000 tonnes of N-AML excavated for disposal on surface in a waste rock disposal area.

5.2.2 Kinect Testing of P-AML Waste Rock

For permanent and temporary storage of P-AML waste rock on surface, Alexco utilizes lined waste rock P-AML WRSFs according to an approved typical design (Section 3.2). Water quality representing accumulated meteoric water combined with pore water within these facilities (e.g. KV-78a, KV-78b, KV-99 and KV-106) are required by the water licence to be monitored monthly between May and October for field parameters including zinc, ammonia, turbidity, pH, temp, conductivity, and water level within the facility. A more detailed external laboratory suite is required quarterly, and includes total and dissolved ICP metals, phosphorus, sulphate, dissolved organic carbon, and hardness.

Analysis of collected waters from these lined P-AML waste rock facilities is superior to lysimeters or other smaller scale kinetic testing methods in that they fully represent the actual bulk drainage chemistry for the in-situ weathering conditions for all P-AML waste temporarily or permanently stored at surface.

6 ADAPTIVE MANAGEMENT

In addition to measures described above, an Adaptive Management Plan (AMP) has been prepared for the entire development. As a requirement of Type A Water Licence QZ09-092, Alexco has written an AMP specific to the Bellekeno, Onek, and Lucky Queen undertakings. It is expected that the amended water licence for the addition of Flame & Moth to the production stream will require an update to the AMP.

7 REPORTING

Documentation of waste rock management activities including operational field screening and segregation and ongoing geochemical monitoring and analyses will be compiled and included in the annual mining land use, Quartz Mining License and Water Licence annual reports.

8 CLOSURE AND RECLAMATION

Reclamation and closure of P-AML waste rock storage facilities and N-AML waste rock disposal areas are discussed in the Reclamation and Closure Plan for QML-0009. As part of Closure and Reclamation studies, kinetic testing of N-AML and P-AML for Flame and Moth rock was initiated in 2013. Further kinetic testing will be undertaken as the mining operations in the KHSD are resumed, which will look at the acid generation and metal leaching potential of the waste rock units that will be brought to surface through humidity cells or field bins.

9 REFERENCES

- Access Consulting (2014). Geochemical Rock Characterization, Flame & Moth Project, Keno Hill District, Yukon Letter report prepared for Alexco Keno Hill Mining Corp., September 24, 2014.
- Altura Environmental Consulting (2008a). Review of Historic Keno Static Test Data to Define ARD/ML – Controlling and Correlating Factors. Letter report prepared for Access Consulting Group, January 4, 2008.
- Altura Environmental Consulting (2008b). Geoenvironmental Rock Characterization, Bellekeno Zone. Letter report prepared for Access Consulting Group, January 8, 2008.
- EBA (2008). Typical Waste Containment Facility Design, Keno Hill Silver District, YT Construction Specifications Issued for Use. Report prepared for Alexco Resource Corp., submitted as part of the application for Water Licence QZ09-092.
- EBA (2009). Review of Potential Site for Typical Waste Rock Containment Facility, Bellekeno East Adit, Keno Hill Silver District, YT. Issued for Use, Report prepared for Alexco Resource Corp., July 30, 2009.
- EBA (2010). Response to Water Board Questions – Bellekeno Waste Rock Dump. Issued for Use, Report prepared for Alexco Resource Corp., April 1, 2010.
- EBA (2011). Lucky Queen Waste Rock Extension – Conceptual Design, Keno City, Yukon. Issued for Review, Report prepared for Access Consulting Group, November 29, 2011.
- EBA (2012). Waste Storage Facility Design, Lucky Property, Keno City, Yukon. Issued for Use, Report prepared for Alexco Resource Corp., November 14, 2012.
- EBA (2014). Waste Storage Facility Design – Revision 1, Flame & Moth Property, Keno City, Yukon. Issued for Use, Report prepared for Alexco Resource Corp., October 2, 2014.

APPENDIX A

Memorandum

To: Brad Thrall, Alexco Keno Hill Mining Corp.

From: Ethan Allen and Kai Woloshyn

CC: Scott Davidson

Date: February 15, 2013

Re: Review of Lucky Queen Waste Rock Management Criteria – Keno Hill District, Yukon

1 INTRODUCTION

Criteria for Alexco Keno Hill Mining Corporation's (AHKM) waste rock management plan (WRMP) was derived primarily from analysis of Keno Hill District (KHD) static testing results by Altura Environmental Consulting Inc. (Altura 2008a) and geoenvironmental characterization of the Bellekeno deposit also by Altura, (2008b). These studies were used to derive geochemical and field screening criteria to distinguish between rock with the potential to generate net acidity or metal leaching (P-AML) and rocks with low potential for generating net acidity or metal leaching (N-AML). Access Consulting Group (Access) conducted a geochemical characterization of the Lucky Queen deposit (Access, 2011) in which the waste rock management criteria were modified due to the low overall neutralizing potential at Lucky Queen.

The field screening criteria relies partly on a visual estimate of sulphide content. Alexco reports that modified waste rock management criteria at Lucky Queen have been difficult for site operations personnel to implement because of the low sulphur cutoff which is used for one of the criterion used to distinguish between P-AML and N-AML rock. This limitation in the ability to accurately resolve the visual sulphide content results in ambiguity, which leads to cautionary de facto designation as P-AML of nearly all of the excavated rock.

Amendment of mine waste by addition of neutralization materials is has been used extensively to improve the acid base accounting (ABA) characteristics of mine waste materials in order to delay or prevent acid rock drainage (ARD) (e.g. Rose et al., 1995; Skousen and Larew, 1994; Wiram and Naumann, 1995).

This memo undertakes a review of the Lucky Queen geochemical data and presents options and recommendations regarding the addition of neutralizing materials in order to amend Lucky Queen waste rock

The objective of this memo is to provide information toward the development of revised waste rock management criteria for Lucky Queen which will be achievable for site operations personnel.

2 METHODS

Thresholds for metal leaching of zinc and lead in Altura (2008a) were based on the distribution of samples of 24-hour shake flask extraction (SFE) testing results of 47 samples from district wide historical waste rock and pit dumps. Criteria of 10 mg/kg Zn and 3 mg/kg Pb were selected based on the logarithmic distribution plots and horizontal inflection points which indicated division between populations of samples which showed higher and lower metal leaching.

In addition to the 47 samples used by Altura (2008a), additional static testing data from SRK, 2012 (78 samples) and Access Consulting Group (ACCESS, 2012), 40 samples for a total of 165 samples were used in this study. The 78 samples analyzed reported by SRK (2012) reported results after 18 hours. The remaining data used 24 hour shake flask extraction. Deionized water as the extracting fluid and used a 3:1 liquid to solids ratio. Corresponding ICP metals data by ICP-MS or ICP-OES was used for each sample. ABA data was also available for most samples but was not used in the analysis.

3 RESULTS

Prior to combining the data, 18 hour SFE test results for selected parameters of interest were compared with the 24 hour tests in order to determine if there was any significant increase in dissolution and apparently leachability in the 24 hour tests. Box plots comparing 18 hour and 24 hour test results for calcium, lead and zinc leaching are presented in Figure 1. Median values for all of these parameters are similar to, or greater in the 18 hour tests. This indicates that the additional time does not increase leachability, and that the test results are comparable.

Fresh samples (N =29) were compared with weathered samples (N= 136) in order to determine if fresh samples contained higher contained calcium, as Altura (2008b) adjusted the calcium criteria by a factor of 1.5 since correlation factors were derived using weathered rock while the waste rock management plan was implemented for fresh rock. Figure 2 shows that fresh samples contain significantly more calcium than weathered samples.

3.1 SAMPLE REACTIVITY CRITERIA

Following the methodology of Altura (2008a), the leachate extraction dataset was examined to determine levels of leachate pH, Zn loading and Pb loading that serve to divide populations and determine potential alternative, more conservative population breaks existed from those used by Altura (2008a). Figure 2 through Figure 5 in Attachment 1 show histograms and cumulative distribution plots for leachate pH and leachate concentration (converted to mg/kg) for zinc, lead and cadmium.

Net Acidity: Leachate pH criteria of <5.5 was selected by Altura (2008a) to differentiate samples generating net acidity. Although the additional data presented in Figure 3 do not show two distinct populations, pH 5.5 is located at the edge of a horizontal inflection point in the cumulative relative frequency curve. These results confirm that the leachate pH criteria of <5.5 is appropriate for differentiating the samples generating net acidity.

Metal Leaching: Altura (2008a) used 10 mg/kg zinc and 3 mg/kg lead as the criteria for metal leaching based on logarithmic distribution plots. The additional data presented in Figure 3 result in a less clear division in populations than was found by Altura (2008a). However, a distinct inflection point still exists between 2 and 3 mg/kg on the cumulative distribution plot, indicating that 3 mg/kg is still appropriate for dividing populations between low and high lead leaching.

Figure 5 shows that the additional data still indicate an inflection point at 10 mg/kg leachable zinc. Another inflection point exists at 2 mg/kg. 2 mg/kg is chosen as a second, more conservative threshold to distinguish between populations and can be used to determine a lower contained zinc threshold for waste rock to be used for construction near water courses.

3.2 REVIEW OF KEY CONTROLLING AND CORRELATING FACTORS FOR SAMPLE REACTIVITY

Contained calcium and sulphur via trace metals ICP are plotted in Figure 6 and Figure 7 with color as leachate pH and leachate dissolved zinc, respectively. Color gradient inflection points were chosen to be the same as those used by Altura (2008a) for ease of comparison. Figure 6 shows that the upper left quadrant bound by 0.25% sulphur and 0.51% calcium contains the majority of samples with leachate pH below 5. This quadrant also contains a number of samples with pH > 5.5. The threshold for calcium was increased to 0.75% by Altura (2008b) for application to waste rock management criteria in order to account for the difference between the weathered rock (on which the ARD/ML study was based on) and fresh rock, which contains more calcium. The expanded dataset includes both weathered and fresh rock samples. Figure 7 shows that samples with zinc leaching greater than 2 mg/kg are largely constrained to samples with greater than 0.25% sulphur and less than 0.75% calcium. 9 of 79 samples with < 0.25% S and > 0.51% Ca showed zinc leaching above 1 mg/kg, with 3 of samples greater than 10 mg/kg. Of these samples, 7 had contained zinc of greater than 1100 ppm.

Figure 8 shows leachable zinc versus contained zinc with color gradient as leachate pH. Criteria of 10 mg/kg (Altura, 2008a) and 2 mg/kg ppm zinc are shown with corresponding cut-offs of 5000 and 1100 ppm zinc. As can be seen in Figure 8, 9 samples with contained zinc of between 5000 and 1100 ppm with pH > 5.5 exhibit zinc leaching of greater than 10 mg/kg with one sample reaching 224.1 mg/kg. Reducing the zinc criteria to 1100 ppm eliminates all but one sample with pH > 5.5 which shows zinc leaching of greater than 2 mg/kg.

Figure 9 shows that a cut-off of 5000 ppm eliminates all samples with leachable lead of >3 mg/kg and pH < 5.5. A number of samples (16) exhibit pH < 5.5 but do not show lead leaching over 3 mg/kg.

In summary, key controlling and correlating factors for sample reactivity derived by Altura to identify samples with the potential for generating net acidity (pH > 5.5) remain accurate when including the additional data. Derived ICP criteria of 5000 ppm lead were accurate for identifying samples with elevated leachable lead of >3 mg/kg for the additional data. The derived ICP criteria of 5000 ppm zinc was largely accurate but did not identify all samples with neutral pH and leachable zinc of <10 mg/kg zinc (9 samples with leachable zinc >10 mg/kg vs. 101 samples <10 mg/kg).

A lower zinc cutoff of 1100 ppm resulted in selection of all samples below 2 mg/kg zinc leaching with pH > 5.5 except for one sample which showed 3.15 mg/kg leachable zinc. This lower contained zinc threshold is recommended where selective identification of rock with ultra-low leachable zinc is desirable, i.e. for construction near water bodies.

4 INPUT TERMS FOR MASS LOADING MODELS

GoldSim mass loading modelling has been completed for the Christal Creek and Lightning Creek watersheds. The predictive modeling has included the proposed deposition of N-AML waste rock from Bellekeno, Onek and Lucky Queen. The potential metal leaching load for the contaminants of concern, cadmium and zinc, from the N-AML waste rock was calculated using 50% of the Waste Rock Management Plan N-AML metal leaching criteria thresholds (10 mg zinc /kg waste rock and 1.1 mg cadmium /kg waste rock) . This approach is an overly conservative estimation in metal leaching the mean capability for N-AML waste rock for cadmium and zinc. Table 1 provides summary statistics for N-AML waste rock in the KHSD.

In addition, geochemical data sets tend to be positively skewed (Scott and Pain, 2008) which can result in the highest (threshold) value in being orders of magnitude higher than the median or geometric mean. With a positively skewed data set, half the threshold value is also likely to be significantly higher than the median or geometric mean value.

In order to come up with more representative terms for potential loading from waste rock, the data were filtered as per the waste rock management plan for Bellekeno and Onek for all of the geochemical thresholds (screening criteria) as above. With the samples filtered for these criteria, 75 of 165 were selected. Summary statistics for this subset are shown in Table 1 below:

Table 1: Summary statistics for key parameters, filtered as N-AML

Statistic	LCH_Pb (mg/kg)	LCH_Zn (mg/kg)	LCH_Cd (mg/kg)	Pb (ppm)	Zn (ppm)	Cd (ppm)	Ca (%)	S (%)
No. of observations	75	75	75	75	75	75	75	75
Minimum	0.000	0.009	0.0000	1.000	11.000	0.050	0.020	0.010
Maximum	1.626	224.100	5.4300	3506.370	3221.700	55.140	8.320	1.280
1st Quartile	0.001	0.014	0.0002	9.450	108.500	0.300	0.085	0.020
Median	0.007	0.030	0.0013	79.000	276.000	2.900	0.970	0.050
3rd Quartile	0.058	0.254	0.0181	674.500	596.800	9.300	2.470	0.230
Mean	0.090	3.974	0.1133	519.038	509.384	7.251	1.920	0.179
Variance (n-1)	0.058	685.897	0.4246	727183	504541	110	5.858	0.064
Standard deviation (n-1)	0.242	26.190	0.6516	852.751	710.311	10.477	2.420	0.253
Skewness (Pearson)	4.510	8.106	7.5552	2.104	2.550	2.391	1.431	1.993
Skewness (Fisher)	4.603	8.272	7.7102	2.147	2.602	2.440	1.460	2.034
Skewness (Bowley)	0.789	0.863	0.8667	0.791	0.314	0.422	0.258	0.714
Geometric mean	0.009	0.071	0.0015	79.268	228.024	1.989	0.562	0.070

As can be seen in Table 1, after filtering the dataset according to the waste rock management plan geochemical screening criteria, for N-AML samples, the maximum value for leachable zinc is 224.1mg/kg while the median is 0.036 mg/kg and the geometric mean is 0.075 mg/kg, or approximately 4 orders of magnitude apart. The geometric mean for leachable cadmium is 0.0015 and the median is 0.0013 for this subset. It is suggested that the geometric mean might be more appropriate for a realistic estimate of potential

N-AML waste rock pore water concentration. Significant positive skewness is noted for all parameters but particularly leachable lead, cadmium and zinc.

Filtering the data according to the waste rock management plan geochemical screening criteria but with the zinc threshold of 1100 ppm results in 67 of 165 samples selected. Summary statistics for this subset are shown in Table 2:

Table 2: Summary statistics for key parameters, filtered as N-AML and samples <1100 ppm zinc

Statistic	LCH_Pb (mg/kg)	LCH_Zn (mg/kg)	LCH_Cd (mg/kg)	Pb (ppm)	Zn (ppm)	Cd (ppm)	Ca (%)	S (%)
No. of observations	67	67	67	67	67	67	67	67
Minimum	0.000	0.009	0.0000	1.000	11.000	0.050	0.020	0.010
Maximum	1.626	38.100	1.6200	3506.370	1100.000	27.430	8.320	0.710
1st Quartile	0.001	0.011	0.0002	7.450	100.500	0.265	0.070	0.020
Median	0.006	0.030	0.0008	48.000	182.000	2.000	0.810	0.040
3rd Quartile	0.042	0.134	0.0072	530.450	439.500	7.650	2.470	0.175
Mean	0.089	0.894	0.0406	439.827	299.700	4.673	1.898	0.133
Variance (n-1)	0.064	23.094	0.0415	681547	71341	36.078	6.258	0.032
Standard deviation (n-1)	0.254	4.806	0.2036	825.559	267.097	6.006	2.502	0.178
Skewness (Pearson)	4.390	7.204	7.2132	2.413	1.025	1.750	1.417	1.713
Skewness (Fisher)	4.492	7.370	7.3795	2.469	1.049	1.790	1.450	1.752
Skewness (Bowley)	0.758	0.683	0.8167	0.845	0.519	0.530	0.383	0.742
Geometric mean	0.007	0.051	0.0010	58.646	174.765	1.465	0.492	0.058

Using the geochemical screening criteria in the waste rock management plan with a lower zinc cutoff of 1100 ppm results in a maximum value of 38.1 mg/kg leachable zinc with a median value of 0.03 mg/kg and geometric mean value of 0.051 mg/kg zinc. The geometric mean for leachable cadmium is 0.001 and the median is 0.0008 for this subset.

5 CONCLUSIONS

- Leachate pH of <5.5 is appropriate for differentiating samples generating net acidity although a significant proportion of samples with >0.25% S and <0.75% Ca do not demonstrate pH < 5.5
- Sample reactivity criteria for lead leaching of 3 mg/kg is indicated by the distribution of samples and corresponds well with a contained lead content of 5000 ppm, excluding samples with pH < 5.5
- Sample reactivity criteria for zinc leaching of 10 mg/kg is indicated by the distribution of samples. A second inflection point at 2 mg/kg can be used to derive a more conservative criterion for zinc. The contained zinc threshold >5000 ppm identifies most samples with pH >5.5 having leachable zinc of >10 mg/kg. However, approximately 10% of the samples with <5000 ppm and pH >5.5 show zinc leaching above 10 mg/kg. The lower contained zinc threshold of >1100 ppm identifies all but one sample with pH >5.5 above 2 mg/kg leachable zinc.
- Modified waste rock management geochemical criteria with a lower contained zinc threshold of <1100 ppm is recommended to select waste rock to be used near (within 30m) of a water course. This corresponds with a field screening criterion of 0.165% sphalerite (trace to no visible sphalerite is recommended). If waste rock from Lucky Queen is selected for construction near a water course, specific waste rock management criteria derived for Lucky Queen (Access, 2011b) are recommended.

Lucky Queen waste rock management criteria differ in that a lower sulphur criterion of 0.15% is used because available neutralizing potential is lower at Lucky Queen.

- The use of the geometric mean values for samples filtered according to all criteria of the geochemical screening criteria is recommended for calculating a representative or realistic estimate of potential concentrations and metal loads from N-AML waste rock disposal areas.

References:

- Access (2011a). Geochemical Rock Characterization, Lucky Queen. Memorandum prepared for Alexco Keno Hill Mining Corp, December 2011.
- Access Consulting Group (2011a). Geochemical Rock Characterization, Onek. Memorandum prepared for Alexco Keno Hill Mining Corp, December 2011.
- Altura Environmental Consulting (2008a). Review of Historic Keno Static Test Data to Define ARD/ML – Controlling and Correlating Factors. Letter report prepared for Access Consulting Group, January 4, 2008.
- Altura Environmental Consulting (2008b). Geoenvironmental Rock Characterization, Bellekeno Zone. Letter report prepared for Access Consulting Group, January 8, 2008.
- Ecometrix (2012) Lucky Queen and Onek Deposit Production Project – Review of Effects on Aquatic Resources. Report prepared for Yukon Environmental and Socio-economic Assessment Board Mayo Designated Office, July 2012.
- Rose, A.W., Phelps, L.B., Parizek, R.R., and D.R. Evans, 1995. Effectiveness of lime kiln flue dust in preventing acid mine drainage at the Kauffman surface coal mine, Clearfield County, Pennsylvania. In: Proceedings American Society for Surface Mining and Reclamation, Gillette, WY, 159-171.
- Scott, K.M., Pain, C.F. (2008). *Regolith Science*. Springer. Collingwood, Australia.
- Skousen, J., and G. Larew, 1994. Alkaline overburden addition to acid-producing materials to prevent acid mine drainage. In: Proceedings International Land Reclamation and Mine Drainage Conference, U.S. Bureau of Mines SP 06B-94, Pittsburgh, PA, 375-381.
- SRK Consulting Canada Inc. (2012). Supplemental Waste Rock Characterization. Memorandum prepared for Access Consulting Group, April 25, 2012
- Wiram, V.P., and H.E. Naumann, 1995. Alkaline additions to the backfill: A key mining/ reclamation component to acid mine drainage prevention. In: Proceedings 16th Annual Surface Mine Drainage Task Force Symposium, West Virginia University, Morgantown, WV.

Attachments:

Attachment 1: Figures



ATTACHMENT 1

FIGURES

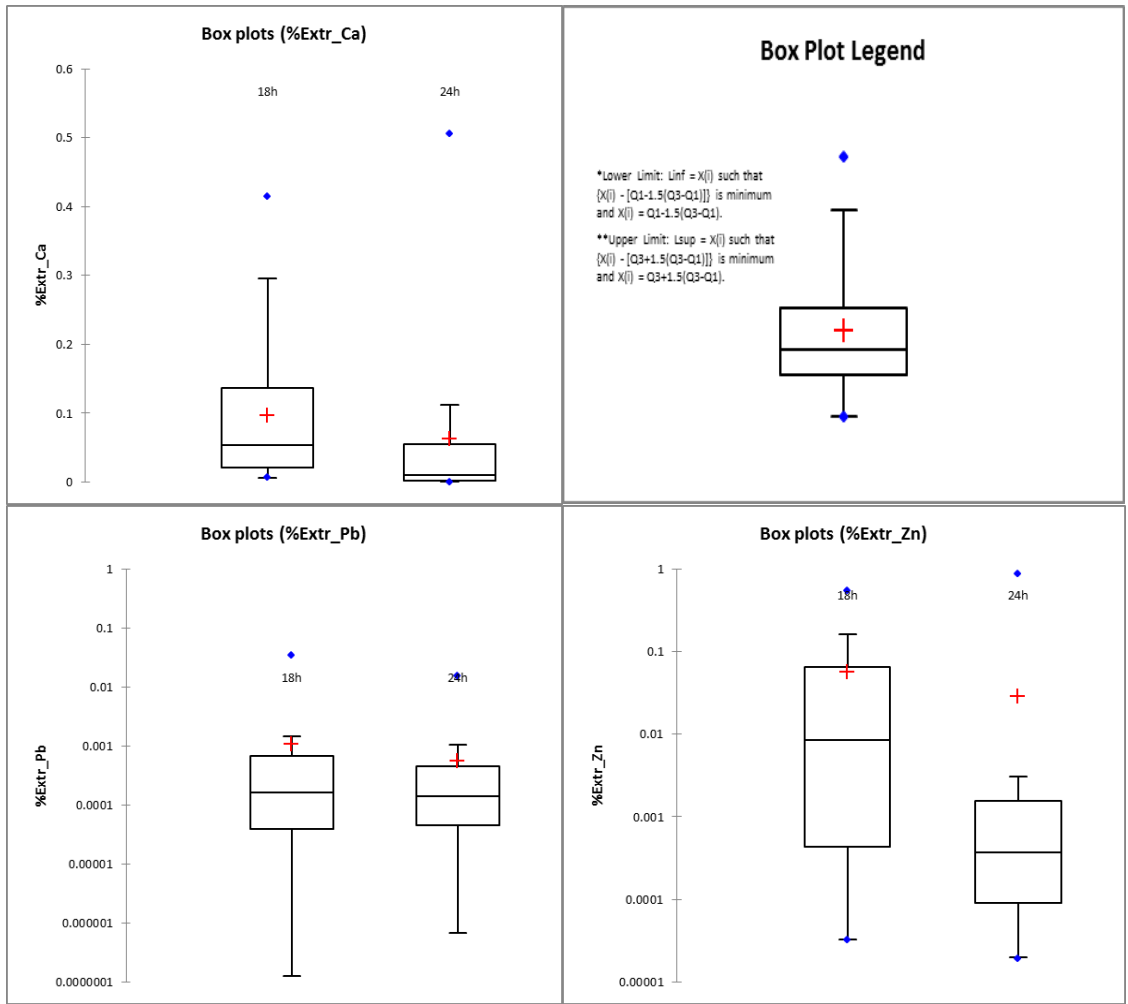

Figure 1: Percent extraction for select parameters, 18 hour vs. 24 hour shake flask extraction tests

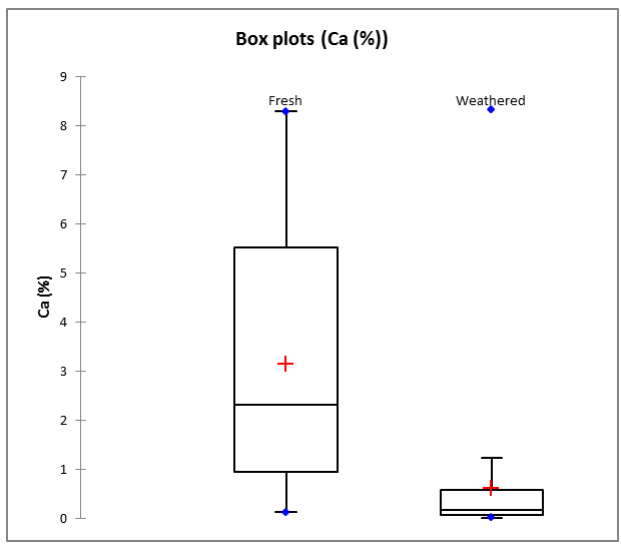

Figure 2: Contained calcium in fresh vs. weathered samples

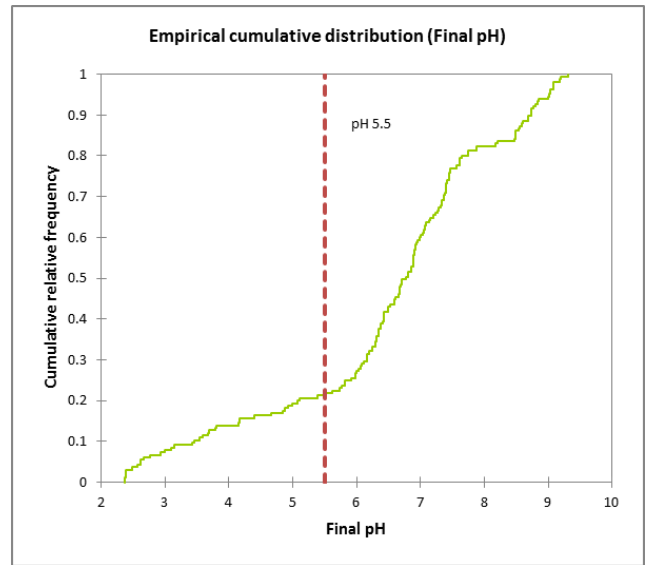
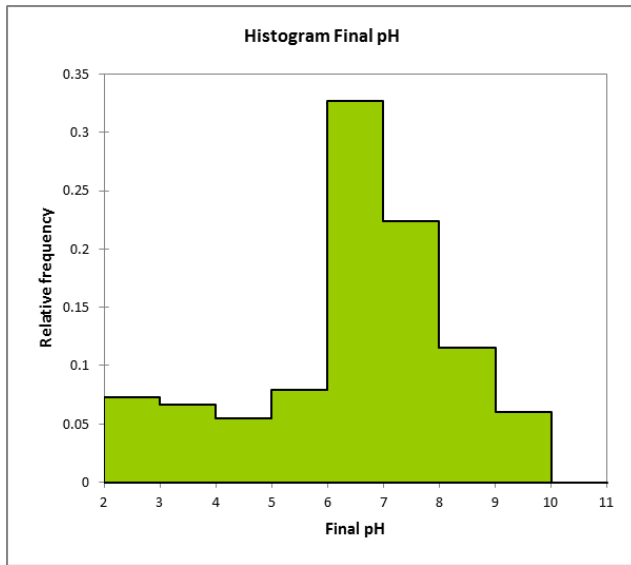

Figure 3: Histograms and cumulative distribution curve for pH

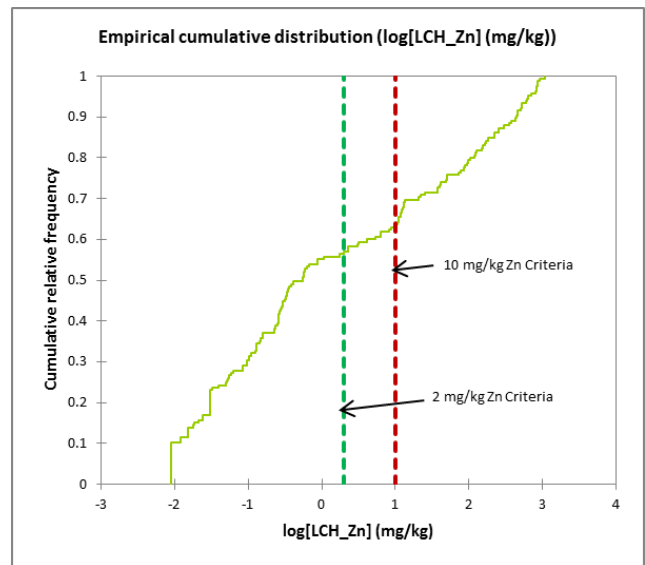
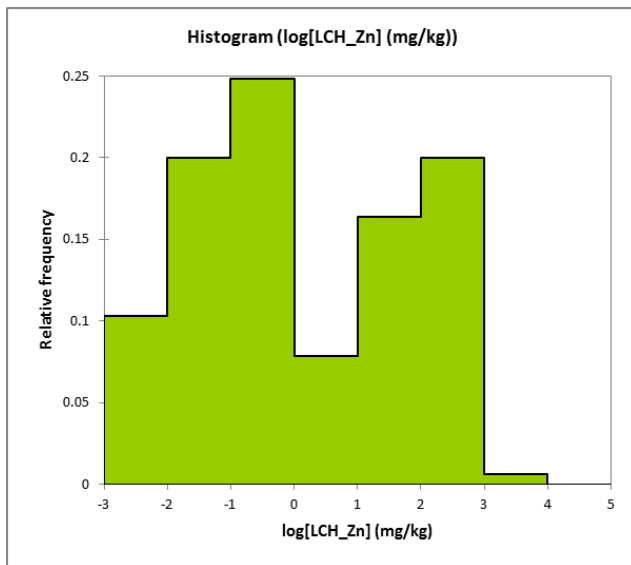

Figure 4: Histograms and cumulative distribution curve for leachable zinc

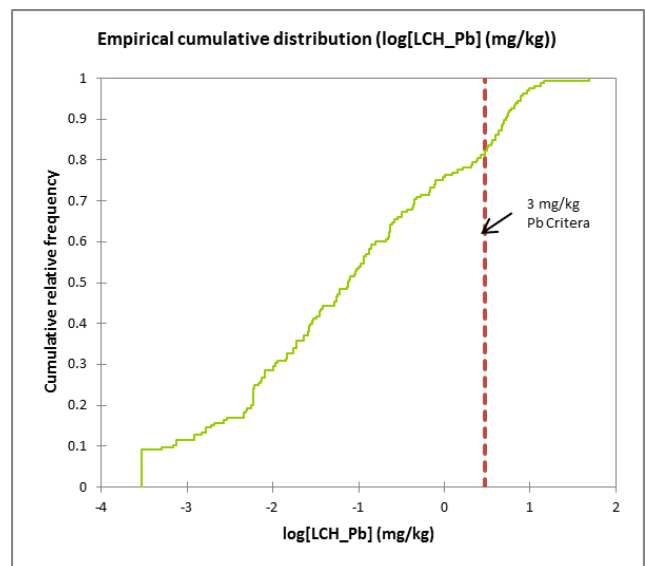
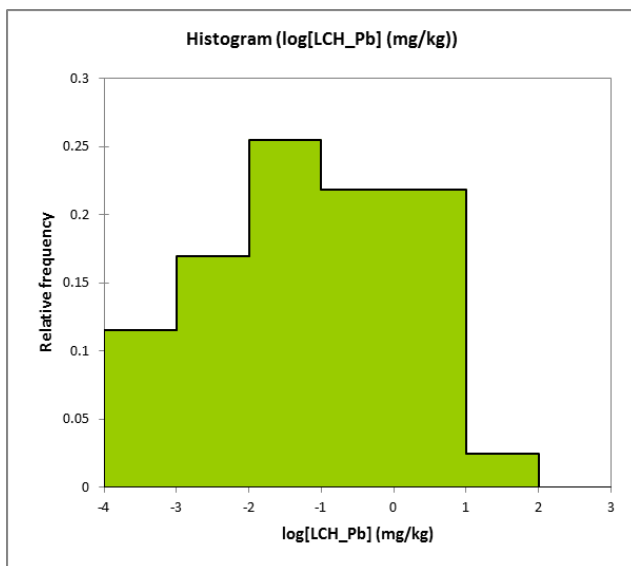

Figure 5: Histograms and cumulative distribution curve for leachable lead

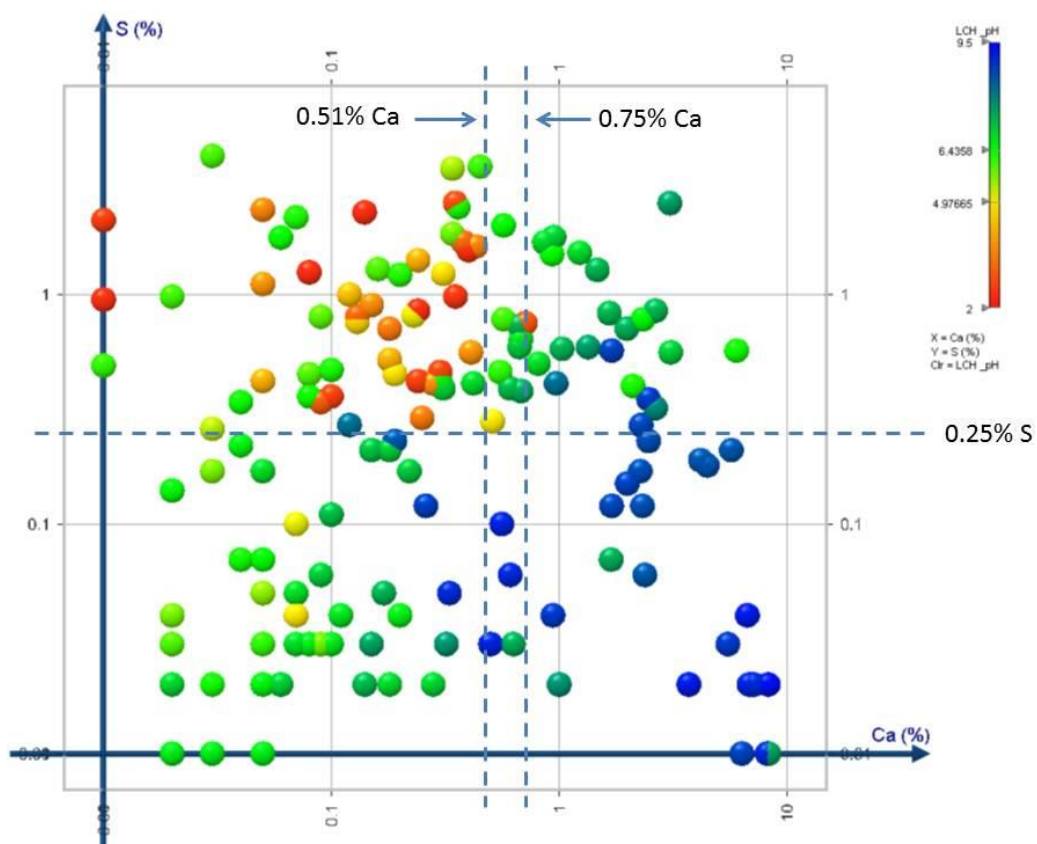

Figure 6: Calcium vs Sulphur rock analyses with leachate pH color gradient

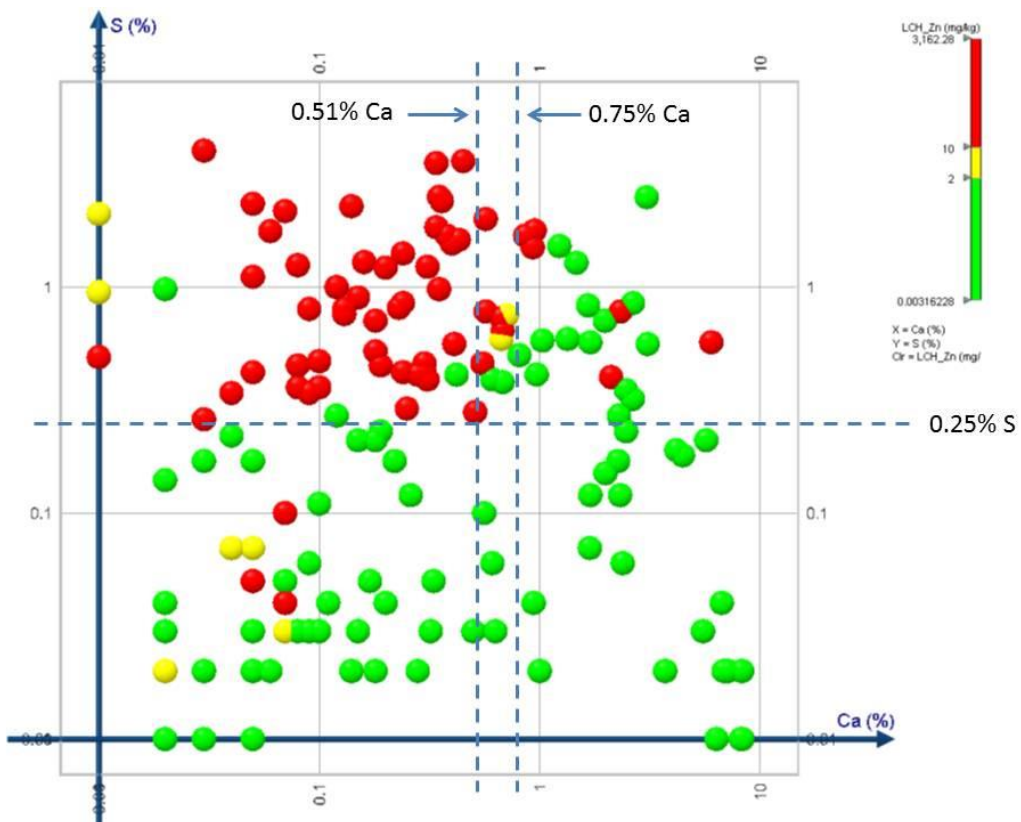

Figure 7: Calcium vs Sulphur rock analyses with leachate dissolved zinc as color interval

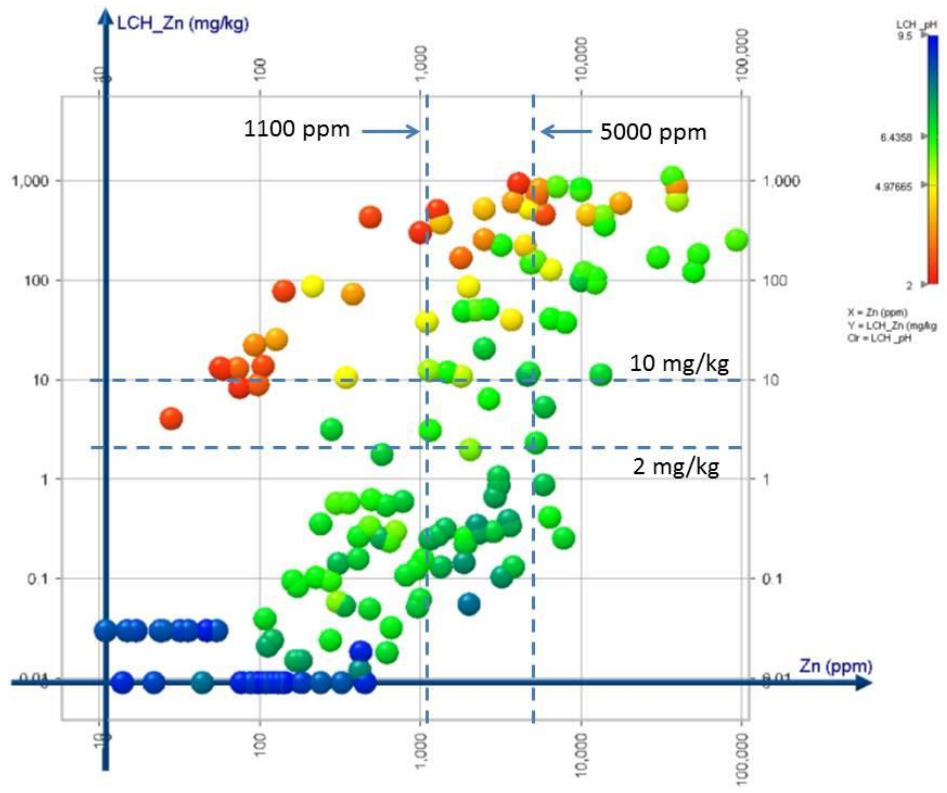

Figure 8: Leachate dissolved zinc vs. contained zinc with leachate pH as color gradient

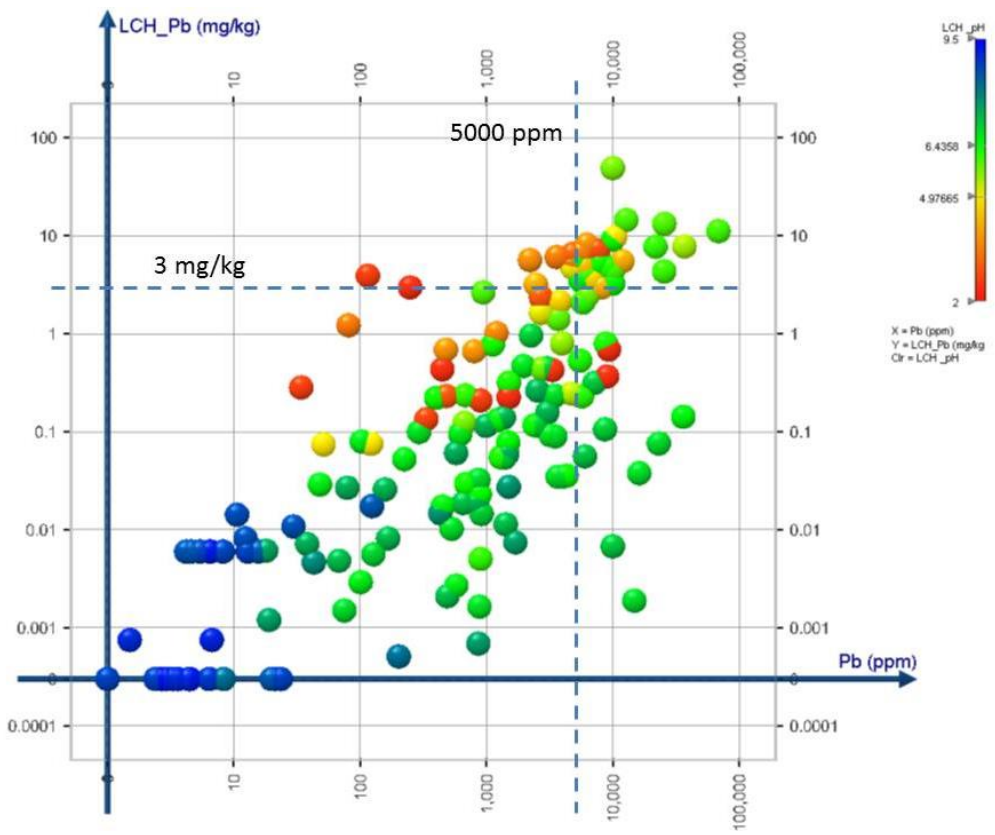

Figure 9: Leachate dissolved lead vs. contained lead with leachate pH as color gradient

APPENDIX B

Memorandum

To: Brad Thrall, Alexco Keno Hill Mining Corp.

From: Ethan Allen and Kai Woloshyn

CC: Scott Davidson

Date: November 15, 2012

Re: Review of Net Acid Generation and Metal Leaching Controlling and Correlating Factors – Keno Hill District

1 INTRODUCTION

Criteria for Alexco Keno Hill Mining Corporation's (AHKM) waste rock management plan (WRMP) was derived primarily from analysis of Keno Hill District (KHD) static testing results by Altura Environmental Consulting Inc. (Altura 2008a) and geoenvironmental characterization of the Bellekeno deposit also by Altura, (2008b). These studies were used to derive geochemical and field screening criteria to distinguish between rock with the potential to generate net acidity or metal leaching (P-AML) and rocks with low potential for generating net acidity or metal leaching (N-AML).

During AHKM's Lucky Queen-Onek new mine permitting YESAB assessment 2011-0315, Ecometrix Inc. (2012) suggested that "AKHM evaluate the risk of using N-AML waste rock with elevated zinc content as construction and upgrade materials and establish appropriate mitigation measures for the use of these materials near waterways, criteria for use may include factors such as a zinc content limit or minimum distance requirement from surface water."

The purpose of this review is to re-examine correlating and controlling factors for net acid generation and metal leaching (AML) in the KHD and assist with selection of a more stringent criteria for waste rock from development with elevated zinc concentrations to be used for infrastructure construction near water bodies (e.g. road construction at creek crossings).

2 METHODS

Thresholds for metal leaching of zinc and lead in Altura (2008a) were based on the distribution of samples of 24-hour shake flask extraction (SFE) testing results of 47 samples from district wide historical waste rock and pit dumps. Criteria of 10 mg/kg Zn and 3 mg/kg Pb were selected based on the logarithmic distribution plots and horizontal inflection points which indicated division between populations of samples which showed higher and lower metal leaching.

In addition to the 47 samples used by Altura (2008a), additional static testing data from SRK, 2012 (78 samples) and Access Consulting Group (ACCESS, 2012), 40 samples for a total of 165 samples were used in this

study. The 78 samples analyzed reported by SRK (2012) reported results after 18 hours. The remaining data used 24 hour shake flask extraction. Deionized water as the extracting fluid and used a 3:1 liquid to solids ratio. Corresponding ICP metals data by ICP-MS or ICP-OES was used for each sample. ABA data was also available for most samples but was not used in the analysis.

3 RESULTS

Prior to combining the data, 18 hour SFE test results for selected parameters of interest were compared with the 24 hour tests in order to determine if there was any significant increase in dissolution and apparently leachability in the 24 hour tests. Box plots comparing 18 hour and 24 hour test results for calcium, lead and zinc leaching are presented in Figure 1. Median values for all of these parameters are similar to, or greater in the 18 hour tests. This indicates that the additional time does not increase leachability, and that the test results are comparable.

Fresh samples (N =29) were compared with weathered samples (N= 136) in order to determine if fresh samples contained higher contained calcium, as Altura (2008b) adjusted the calcium criteria by a factor of 1.5 since correlation factors were derived using weathered rock while the waste rock management plan was implemented for fresh rock. Figure 2 shows that fresh samples contain significantly more calcium than weathered samples.

3.1 SAMPLE REACTIVITY CRITERIA

Following the methodology of Altura (2008a), the leachate extraction dataset was examined to determine levels of leachate pH, Zn loading and Pb loading that serve to divide populations and determine potential alternative, more conservative population breaks existed from those used by Altura (2008a). Figure 2 through Figure 5 in Attachment 1 show histograms and cumulative distribution plots for leachate pH and leachate concentration (converted to mg/kg) for zinc, lead and cadmium.

Net Acidity: Leachate pH criteria of <5.5 was selected by Altura (2008a) to differentiate samples generating net acidity. Although the additional data presented in Figure 3 do not show two distinct populations, pH 5.5 is located at the edge of a horizontal inflection point in the cumulative relative frequency curve. These results confirm that the leachate pH criteria of <5.5 is appropriate for differentiating the samples generating net acidity.

Metal Leaching: Altura (2008a) used 10 mg/kg zinc and 3 mg/kg lead as the criteria for metal leaching based on logarithmic distribution plots. The additional data presented in Figure 3 result in a less clear division in populations than was found by Altura (2008a). However, a distinct inflection point still exists between 2 and 3 mg/kg on the cumulative distribution plot, indicating that 3 mg/kg is still appropriate for dividing populations between low and high lead leaching.

Figure 5 shows that the additional data still indicate an inflection point at 10 mg/kg leachable zinc. Another inflection point exists at 2 mg/kg. 2 mg/kg is chosen as a second, more conservative threshold to distinguish between populations and can be used to determine a lower contained zinc threshold for waste rock to be used for construction near water courses.

3.2 REVIEW OF KEY CONTROLLING AND CORRELATING FACTORS FOR SAMPLE REACTIVITY

Contained calcium and sulphur via trace metals ICP are plotted in Figure 6 and Figure 7 with color as leachate pH and leachate dissolved zinc, respectively. Color gradient inflection points were chosen to be the same as those used by Altura (2008a) for ease of comparison. Figure 6 shows that the upper left quadrant bound by 0.25% sulphur and 0.51% contains the majority of samples with leachate pH below 5. This quadrant also contains a number of samples with pH > 5.5. The threshold for calcium was increased to 0.75% by Altura (2008b) for application to waste rock management criteria in order to account for the difference between the weathered rock (on which the ARD/ML study was based on) and fresh rock, which contains more calcium. The expanded dataset includes both weathered and fresh rock samples. Figure 7 shows that samples with zinc leaching greater than 2 mg/kg are largely constrained to samples with greater than 0.25% sulphur and less than 0.75% calcium. 9 of 79 samples with < 0.25% S and > 0.51% Ca showed zinc leaching above 1 mg/kg, with 3 of samples greater than 10 mg/kg. Of these samples, 7 had contained zinc of greater than 1100 ppm.

Figure 8 shows leachable zinc versus contained zinc with color gradient as leachate pH. Criteria of 10 mg/kg (Altura, 2008a) and 2 mg/kg ppm zinc are shown with corresponding cut-offs of 5000 and 1100 ppm zinc. As can be seen in Figure 8, 9 samples with contained zinc of between 5000 and 1100 ppm with pH > 5.5 exhibit zinc leaching of greater than 10 mg/kg with one sample reaching 224.1 mg/kg. Reducing the zinc criteria to 1100 ppm eliminates all but one sample with pH > 5.5 which shows zinc leaching of greater than 2 mg/kg.

Figure 9 shows that a cut-off of 5000 ppm eliminates all samples with leachable lead of >3 mg/kg and pH < 5.5. A number of samples (16) exhibit pH < 5.5 but do not show lead leaching over 3 mg/kg.

In summary, key controlling and correlating factors for sample reactivity derived by Altura to identify samples with the potential for generating net acidity (pH > 5.5) remain accurate when including the additional data. Derived ICP criteria of 5000 ppm lead were accurate for identifying samples with elevated leachable lead of >3 mg/kg for the additional data. The derived ICP criteria of 5000 ppm zinc was largely accurate but did not identify all samples with neutral pH and leachable zinc of <10 mg/kg zinc (9 samples with leachable zinc >10 mg/kg vs. 101 samples <10 mg/kg).

A lower zinc cutoff of 1100 ppm resulted in selection of all samples below 2 mg/kg zinc leaching with pH > 5.5 except for one sample which showed 3.15 mg/kg leachable zinc. This lower contained zinc threshold is recommended where selective identification of rock with ultra-low leachable zinc is desirable, i.e. for construction near water bodies.

4 INPUT TERMS FOR MASS LOADING MODELS

GoldSim mass loading modelling has been completed for the Christal Creek and Lightning Creek watersheds. The predictive modeling has included the proposed deposition of N-AML waste rock from Bellekeno, Onek and Lucky Queen. The potential metal leaching load for the contaminants of concern, cadmium and zinc, from the N-AML waste rock was calculated using 50% of the Waste Rock Management Plan N-AML metal leaching criteria thresholds (10 mg zinc /kg waste rock and 1.1 mg cadmium /kg waste rock). This approach is an overly conservative estimation in metal leaching the mean capability for N-AML waste rock for cadmium and zinc. Table 1 provides summary statistics for N-AML waste rock in the KHSD.

In addition, geochemical data sets tend to be positively skewed (Scott and Pain, 2008) which can result in the highest (threshold) value in being orders of magnitude higher than the median or geometric mean. With a

positively skewed data set, half the threshold value is also likely to be significantly higher than the median or geometric mean value.

In order to come up with more representative terms for potential loading from waste rock, the data were filtered as per the waste rock management plan for Bellekeno and Onek for all of the geochemical thresholds (screening criteria) as above. With the samples filtered for these criteria, 75 of 165 were selected. Summary statistics for this subset are shown in Table 1 below:

Table 1: Summary statistics for key parameters, filtered as N-AML

Statistic	LCH_Pb (mg/kg)	LCH_Zn (mg/kg)	LCH_Cd (mg/kg)	Pb (ppm)	Zn (ppm)	Cd (ppm)	Ca (%)	S (%)
No. of observations	75	75	75	75	75	75	75	75
Minimum	0.000	0.009	0.0000	1.000	11.000	0.050	0.020	0.010
Maximum	1.626	224.100	5.4300	3506.370	3221.700	55.140	8.320	1.280
1st Quartile	0.001	0.014	0.0002	9.450	108.500	0.300	0.085	0.020
Median	0.007	0.030	0.0013	79.000	276.000	2.900	0.970	0.050
3rd Quartile	0.058	0.254	0.0181	674.500	596.800	9.300	2.470	0.230
Mean	0.090	3.974	0.1133	519.038	509.384	7.251	1.920	0.179
Variance (n-1)	0.058	685.897	0.4246	727183	504541	110	5.858	0.064
Standard deviation (n-1)	0.242	26.190	0.6516	852.751	710.311	10.477	2.420	0.253
Skewness (Pearson)	4.510	8.106	7.5552	2.104	2.550	2.391	1.431	1.993
Skewness (Fisher)	4.603	8.272	7.7102	2.147	2.602	2.440	1.460	2.034
Skewness (Bowley)	0.789	0.863	0.8667	0.791	0.314	0.422	0.258	0.714
Geometric mean	0.009	0.071	0.0015	79.268	228.024	1.989	0.562	0.070

As can be seen in Table 1, after filtering the dataset according to the waste rock management plan geochemical screening criteria, for N-AML samples, the maximum value for leachable zinc is 224.1mg/kg while the median is 0.036 mg/kg and the geometric mean is 0.075 mg/kg, or approximately 4 orders of magnitude apart. The geometric mean for leachable cadmium is 0.0015 and the median is 0.0013 for this subset. It is suggested that the geometric mean might be more appropriate for a realistic estimate of potential N-AML waste rock pore water concentration. Significant positive skewness is noted for all parameters but particularly leachable lead, cadmium and zinc.

Filtering the data according to the waste rock management plan geochemical screening criteria but with the zinc threshold of 1100 ppm results in 67 of 165 samples selected. Summary statistics for this subset are shown in Table 2:

Table 2: Summary statistics for key parameters, filtered as N-AML and samples <1100 ppm zinc

Statistic	LCH_Pb (mg/kg)	LCH_Zn (mg/kg)	LCH_Cd (mg/kg)	Pb (ppm)	Zn (ppm)	Cd (ppm)	Ca (%)	S (%)
No. of observations	67	67	67	67	67	67	67	67
Minimum	0.000	0.009	0.0000	1.000	11.000	0.050	0.020	0.010
Maximum	1.626	38.100	1.6200	3506.370	1100.000	27.430	8.320	0.710
1st Quartile	0.001	0.011	0.0002	7.450	100.500	0.265	0.070	0.020
Median	0.006	0.030	0.0008	48.000	182.000	2.000	0.810	0.040
3rd Quartile	0.042	0.134	0.0072	530.450	439.500	7.650	2.470	0.175
Mean	0.089	0.894	0.0406	439.827	299.700	4.673	1.898	0.133
Variance (n-1)	0.064	23.094	0.0415	681547	71341	36.078	6.258	0.032
Standard deviation (n-1)	0.254	4.806	0.2036	825.559	267.097	6.006	2.502	0.178
Skewness (Pearson)	4.390	7.204	7.2132	2.413	1.025	1.750	1.417	1.713
Skewness (Fisher)	4.492	7.370	7.3795	2.469	1.049	1.790	1.450	1.752
Skewness (Bowley)	0.758	0.683	0.8167	0.845	0.519	0.530	0.383	0.742
Geometric mean	0.007	0.051	0.0010	58.646	174.765	1.465	0.492	0.058

Using the geochemical screening criteria in the waste rock management plan with a lower zinc cutoff of 1100 ppm results in a maximum value of 38.1 mg/kg leachable zinc with a median value of 0.03 mg/kg and geometric mean value of 0.051 mg/kg zinc. The geometric mean for leachable cadmium is 0.001 and the median is 0.0008 for this subset.

5 CONCLUSIONS

- Leachate pH of <5.5 is appropriate for differentiating samples generating net acidity although a significant proportion of samples with >0.25% S and <0.75% Ca do not demonstrate pH < 5.5
- Sample reactivity criteria for lead leaching of 3 mg/kg is indicated by the distribution of samples and corresponds well with a contained lead content of 5000 ppm, excluding samples with pH < 5.5
- Sample reactivity criteria for zinc leaching of 10 mg/kg is indicated by the distribution of samples. A second inflection point at 2 mg/kg can be used to derive a more conservative criterion for zinc. The contained zinc threshold >5000 ppm identifies most samples with pH >5.5 having leachable zinc of >10 mg/kg. However, approximately 10% of the samples with <5000 ppm and pH >5.5 show zinc leaching above 10 mg/kg. The lower contained zinc threshold of >1100 ppm identifies all but one sample with pH >5.5 above 2 mg/kg leachable zinc.
- Modified waste rock management geochemical criteria with a lower contained zinc threshold of <1100 ppm is recommended to select waste rock to be used near (within 30m) of a water course. This corresponds with a field screening criterion of 0.165% sphalerite (trace to no visible sphalerite is recommended). If waste rock from Lucky Queen is selected for construction near a water course, specific waste rock management criteria derived for Lucky Queen (Access, 2011b) are recommended.

Lucky Queen waste rock management criteria differ in that a lower sulphur criterion of 0.15% is used because available neutralizing potential is lower at Lucky Queen.

- The use of the geometric mean values for samples filtered according to all criteria of the geochemical screening criteria is recommended for calculating a representative or realistic estimate of potential concentrations and metal loads from N-AML waste rock disposal areas.

References:

Access (2011a). Geochemical Rock Characterization, Lucky Queen. Memorandum prepared for Alexco Keno Hill Mining Corp, December 2011.

Access Consulting Group (2011a). Geochemical Rock Characterization, Onek. Memorandum prepared for Alexco Keno Hill Mining Corp, December 2011.

Altura Environmental Consulting (2008a). Review of Historic Keno Static Test Data to Define ARD/ML – Controlling and Correlating Factors. Letter report prepared for Access Consulting Group, January 4, 2008.

Altura Environmental Consulting (2008b). Geoenvironmental Rock Characterization, Bellekeno Zone. Letter report prepared for Access Consulting Group, January 8, 2008.

Ecometrix (2012) Lucky Queen and Onek Deposit Production Project – Review of Effects on Aquatic Resources. Report prepared for Yukon Environmental and Socio-economic Assessment Board Mayo Designated Office, July 2012.

Scott, K.M., Pain, C.F. (2008). *Regolith Science*. Springer. Collingwood, Australia.

SRK Consulting Canada Inc. (2012). Supplemental Waste Rock Characterization. Memorandum prepared for Access Consulting Group, April 25, 2012

Attachments:

Attachment 1: Figures



ATTACHMENT 1

FIGURES

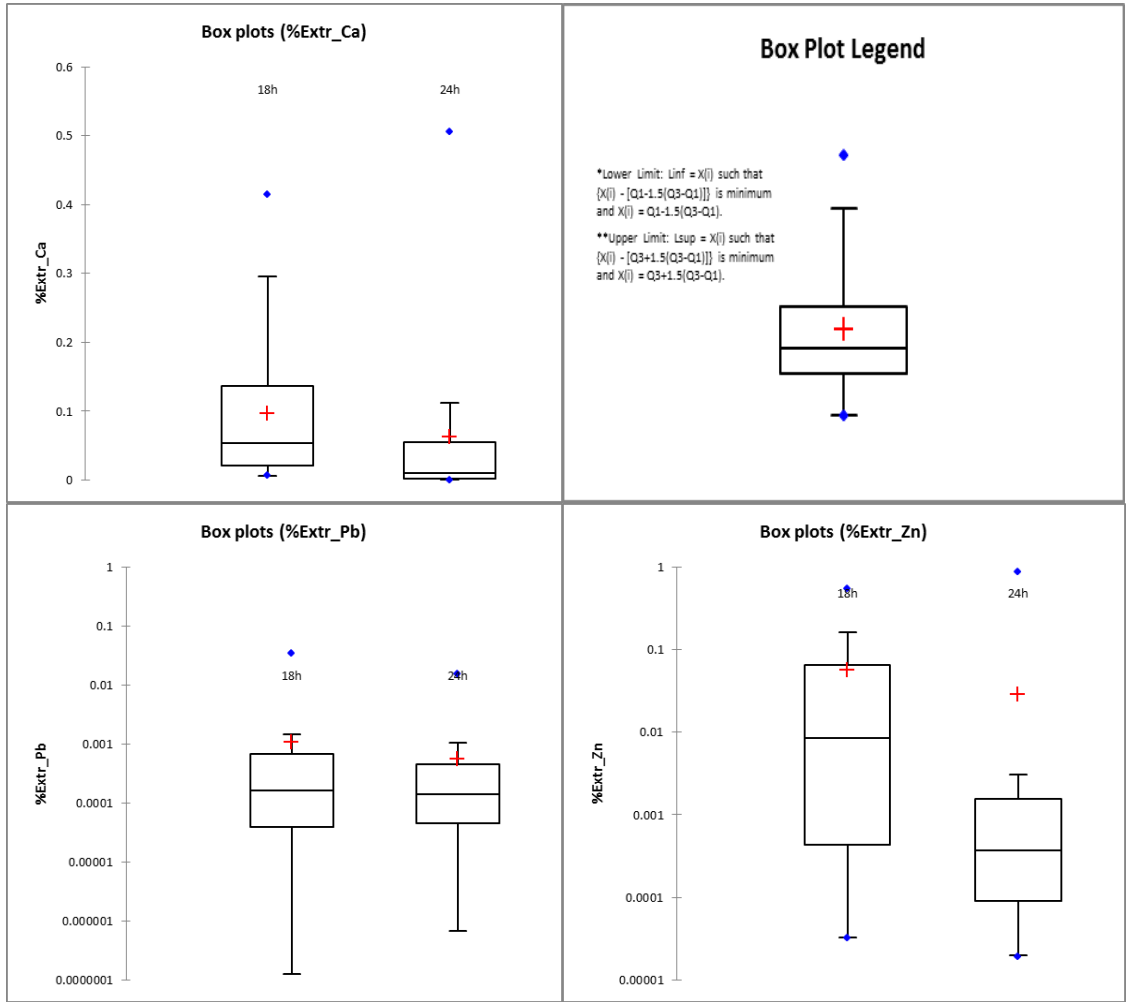

Figure 1: Percent extraction for select parameters, 18 hour vs. 24 hour shake flask extraction tests

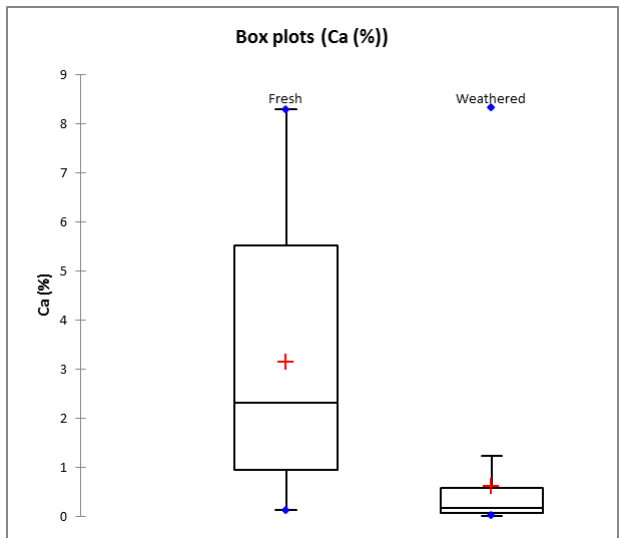

Figure 2: Contained calcium in fresh vs. weathered samples

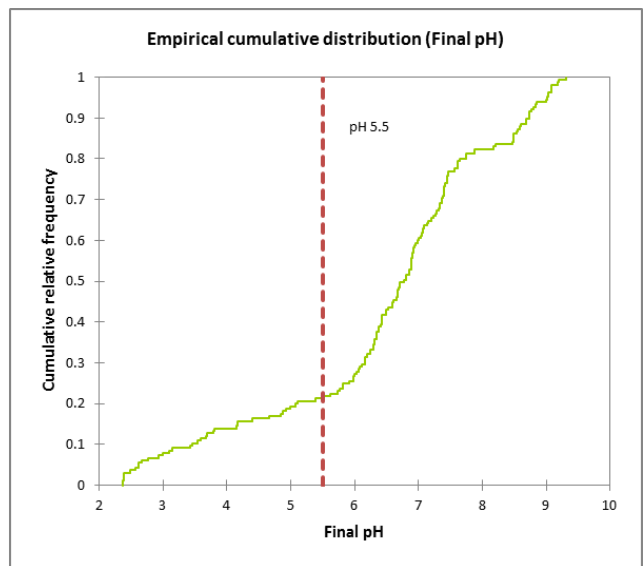
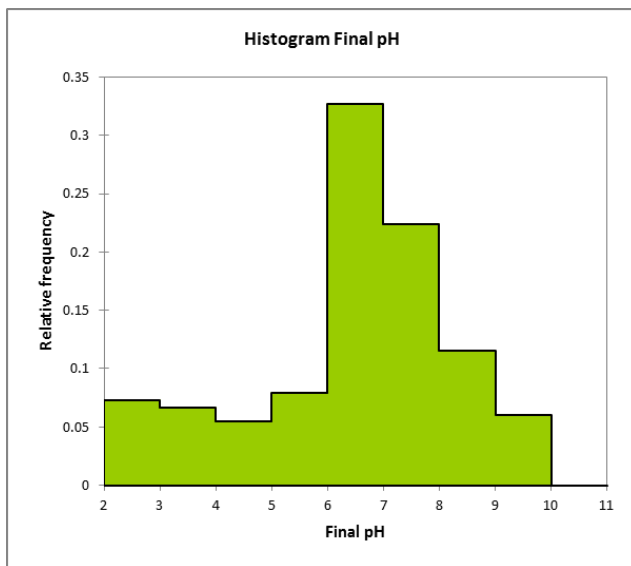

Figure 3: Histograms and cumulative distribution curve for pH

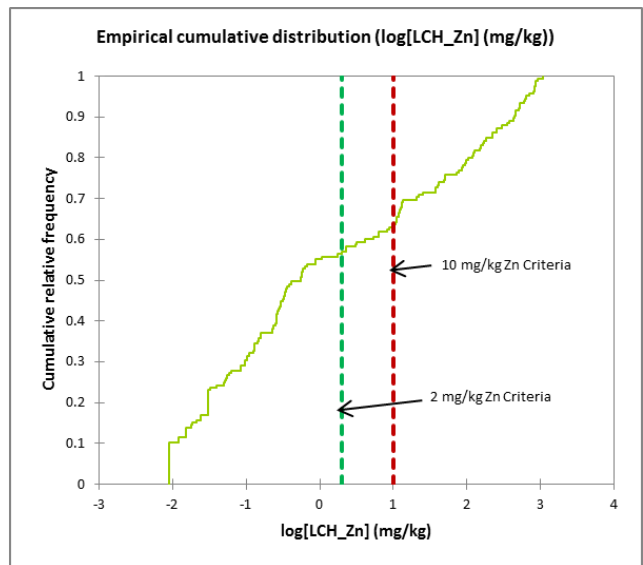
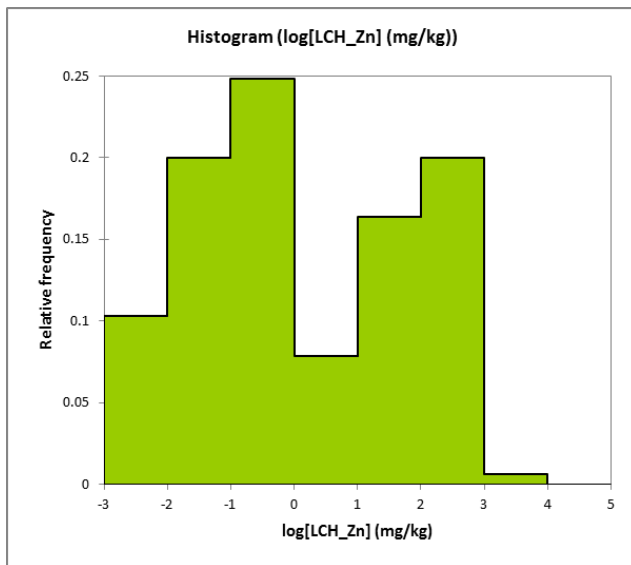

Figure 4: Histograms and cumulative distribution curve for leachable zinc

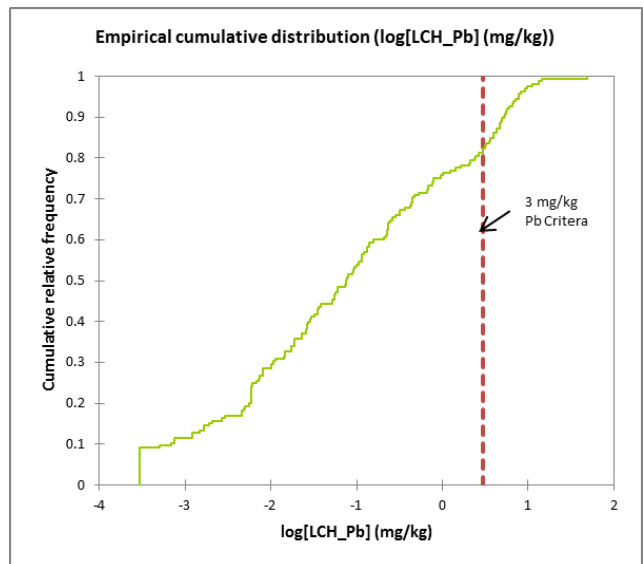
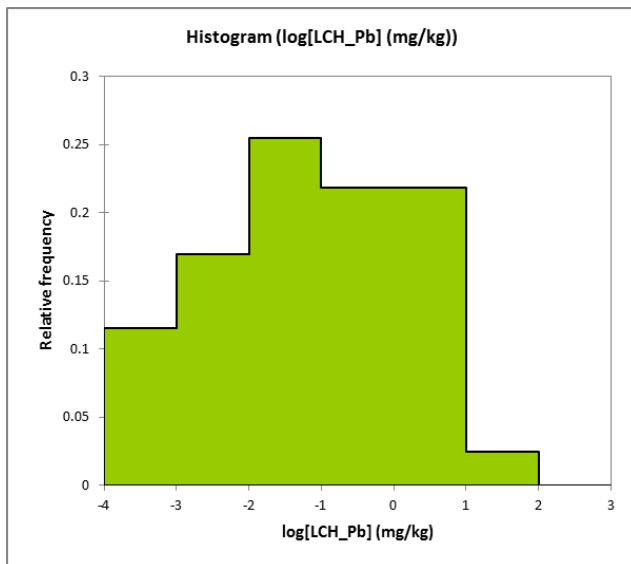

Figure 5: Histograms and cumulative distribution curve for leachable lead

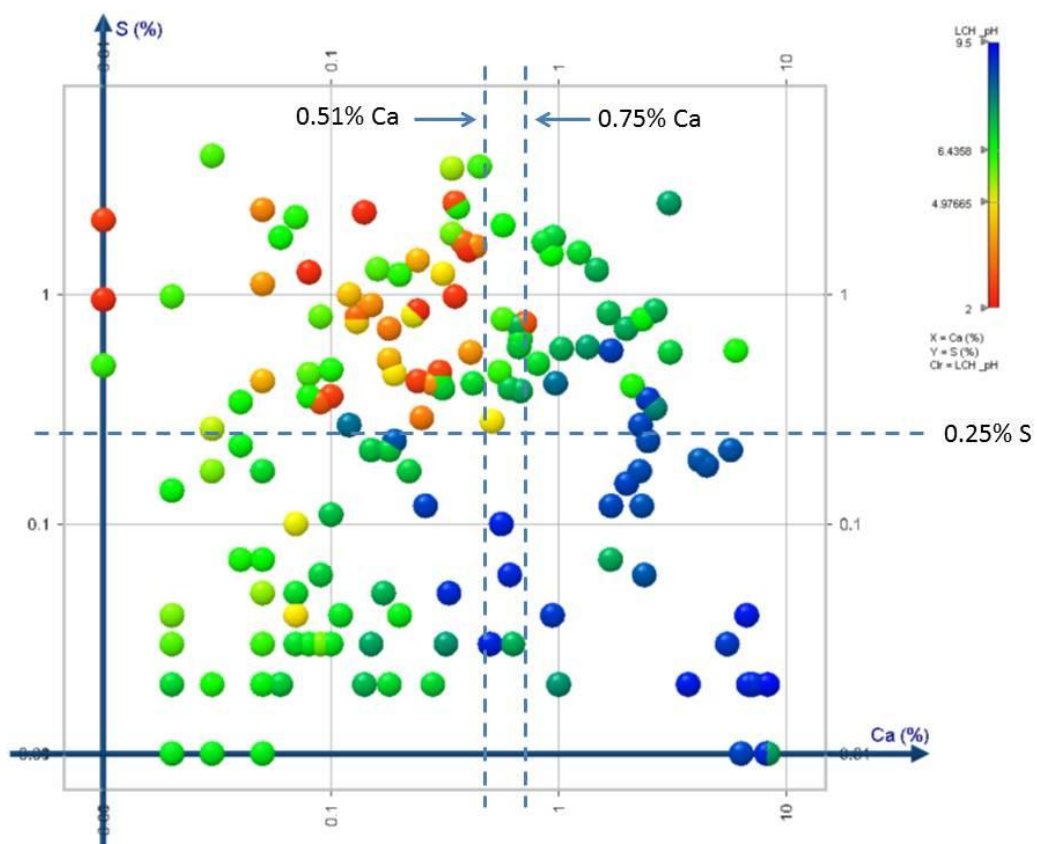

Figure 6: Calcium vs Sulphur rock analyses with leachate pH color gradient

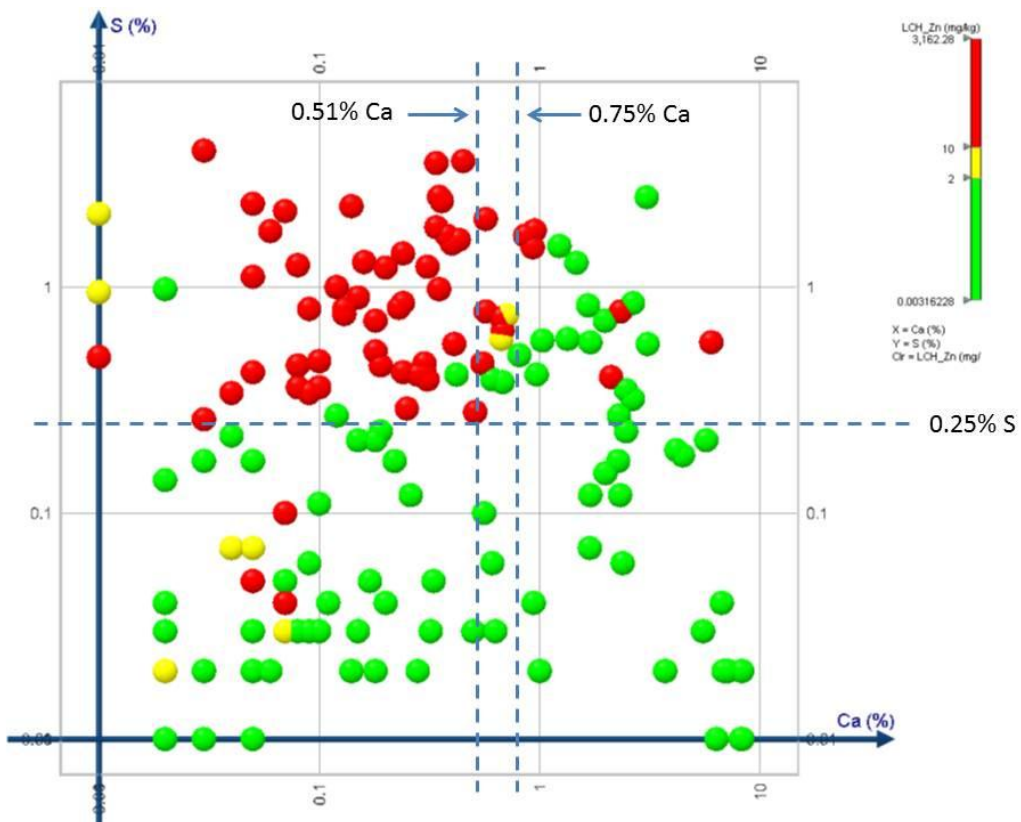

Figure 7: Calcium vs Sulphur rock analyses with leachate dissolved zinc as color interval

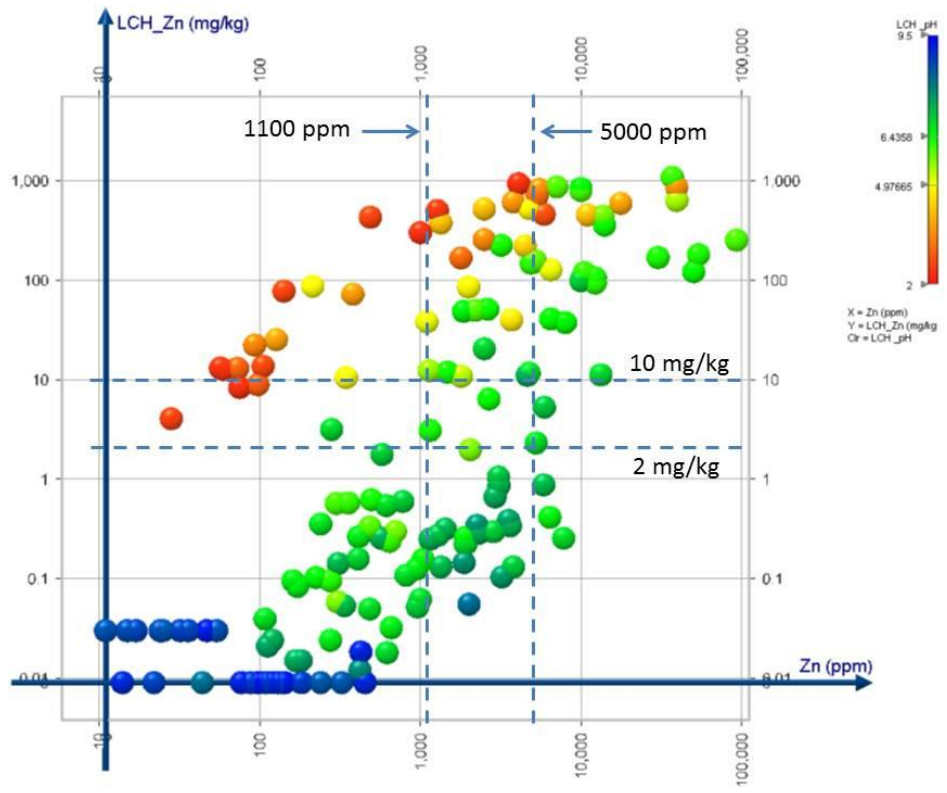

Figure 8: Leachate dissolved zinc vs. contained zinc with leachate pH as color gradient

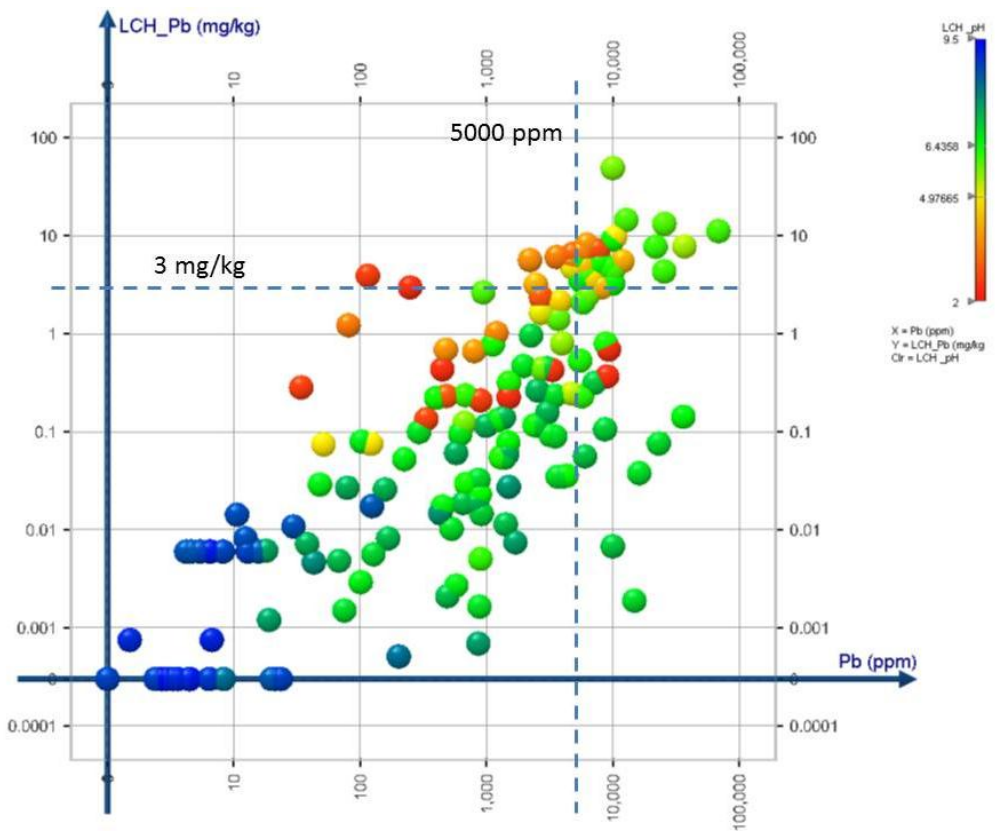

Figure 9: Leachate dissolved lead vs. contained lead with leachate pH as color gradient

APPENDIX C



<u>Section</u>		<u>Number of Pages</u>
Section 1001	Definitions	1
Section 1002	General	2
Section 1003	Fill Materials	2
Section 1004	Fill Placement	2
Section 1005	Liner System	11
Section 1006	Quality Assurance	5
Section 1007	Design Alternatives	2
Section 1008	Operation and Maintenance	2





Appendix A Construction Drawings



Section 1001



□
□
1.0 General

.1 Definitions of terms used throughout the Construction Specifications are presented in this Section.

2.0 Definitions

Construction Drawings: the drawings, as issued for construction, of the Typical Waste Containment Facility Design.

Construction Specifications: this document.

Contract: the legal and binding agreement between the Contractor and Alexco Resource Corp. regarding construction of the Waste Containment Facility.

Contractor: the general contractor responsible for constructing the Waste Containment Facility.

Engineer: the Professional Geotechnical Engineer registered in the Yukon who is associated with the construction process.

Owner: Alexco Resource Corp.

Site: the area in which construction of the Waste Containment Facility or related activity is occurring.

Unsuitable: not meeting the requirements stated herein or not receiving the Engineer's approval.

Facility: all components of the Waste Containment Facility.

END OF SECTION



Section 1002



1.0 General

- .1 Alexco Resource Canada Corp. intends to construct a containment facility to store waste rock from the Bellekeno advanced underground exploration and development program. As the company advances through the Keno Hill Silver District, it is anticipated further underground exploration and development programs will require similar containment facilities. Therefore, a typical design has been developed to account for the various potential site and construction material conditions.
- .2 The Facility is to be located within previously disturbed areas, all of which will be incorporated within a district wide closure plan. This district wide closure plan is required under the water license QZ06-074.
- .3 Site specific conditions and Facility location have not been provided or considered. Once Facility location and site specific conditions are known, they must be reviewed by the Engineer. Furthermore, the base of the Facility must be approved by the Engineer prior to fill placement.
- .4 The Facility will be lined with a suitable geomembrane. Water in the Facility will flow towards the vertical culvert and pond within the voids of the waste material.
- .5 Water in the Facility will be monitored and tested on a regular basis. Based on water quality analysis, the waste water will be extracted via pump truck and discharged to the environment or treated in a designated treatment facility.
- .6 Once the Facility reaches its ultimate capacity, the Facility will be capped and reclaimed.

2.0 Scope of Work

- .1 The scope of work for the construction of the Facility is as follows:
 - a. Construct the liner subgrade and berms with Zone B material at the specified grade. This could include cut/fill operations should the foundation material be satisfactory;
 - b. If required, install a geotextile layer to act as separator for Zone A and Zone B materials;
 - c. Construct the liner bedding with Zone A material;

- d. Install the liner system consisting of a suitable liner material and if required, protective geotextile layers above and below the liner, and a geocomposite reinforcing layer;
- e. Place and compact cover material, Zone A material, over the liner system;
- f. Install vertical culvert as specified on the Construction Drawings;
- g. Place and compact the waste material;
- h. Regrade the waste material and place and compact capping material;
- i. Install vegetative cover.

END OF SECTION



Section 1003



1.0 General

- .1 This section describes the construction material specifications for the Waste Containment Facility.

2.0 Reference Standards

- .1 The most recent copy of American Society for Testing Materials, ASTM C136, Standard Test Method for Sieve Analysis of Fine and Coarse Aggregate.

3.0 Material Sources

- .1 No material of any type shall be borrowed or excavated without the Owner's prior approval.
- .2 Pits and quarries shall be maintained and managed in accordance with the requirements set out in the Owner's Land Use and Quarry Permits.
- .3 Zone A material shall be obtained from sources approved by the Owner, provided the final product meets the requirements specified herein. Processing may be required to achieve the specified gradation.
- .4 Zone B material shall be obtained from sources approved by the Owner, provided the final product meets the requirements specified herein. Processing may be required to achieve the specified gradation.
- .5 The parent rock from which all fill materials are derived shall consist of sound, hard, durable material free from soft, thin, elongated or laminated particles and shall contain no unsuitable substances. The potential quarry source shall be approved by the Engineer.
- .6 The quarry source for the Facility fill materials shall be inspected by the Engineer throughout material processing to ensure the product meets the requirements stated herein.

4.0 Material Specifications

.1 Zone A Material

The Zone A material shall consist of hard, durable particles, shall be free of roots, topsoil, and deleterious material and shall have a particle size distribution, as measured by ASTM C136, as presented in Table 1003.1.

Particle Size (mm)	Zone A Material (%)	Zone B Material (%)
10	100	100
5	80	100
2	55	100
0.63	25	65
0.25	10	40
0.08	2	15

.2 Zone B Material

The Zone B material shall be free of roots, topsoil and other deleterious material and shall have a particle size distribution within the limits presented in Table 1003.2.

Particle Size (mm)	Zone A Material (%)	Zone B Material (%)
200	100	100
100	85	100
50	65	100
25	40	100
5	20	55
2	0	20

END OF SECTION



Section 1004

□ □ □ □ □ □ □ M □ □ □

1.0 General

- .1 The fill placement methods to be used during construction of the Waste Containment Facility are described in this Section.
- .2 Construction shall be performed in accordance with the best modern practice and with equipment best adapted to the work being performed. Embankment materials shall be placed so that each zone is homogeneous; free of stratifications; ice chunks, lenses or pockets; and layers of material with different texture grading not conforming to the requirements stated herein.
- .3 No fill material shall be placed on any part of the foundation until it has been prepared, as specified herein. Placement of fill material shall conform to the lines, grades and elevations shown on the Construction Drawings.
- .4 Embankment construction shall not proceed when the work cannot be performed in accordance with the requirements of the Construction Specifications. Any part of the embankment that has been damaged by the action of rain, snow or any other cause shall be removed and replaced with the appropriate material conforming to the requirements stated herein.
- .5 Stockpiling, loading, transporting, placing, and spreading of all materials shall be carried out in such a manner to avoid segregation. Segregated materials shall be removed and replaced with the materials meeting the requirements stated herein.
- .6 The Contractor shall remove all debris, vegetation or any other material not conforming to the requirements stated herein. The Contractor shall dispose of these materials in an area approved by the Owner.

2.0 Zone B Material Placement

- .1 The Zone B material shall be placed to the design elevation as specified in the Construction Drawings in lifts no greater than 500 mm in uncompacted thickness.
- .2 The design elevation for the top of the Zone B berm material shall be no less than 0.5 m above original ground.
- .3 Moisture condition and compact using the minimum number of passes established in accordance with section 1006.4.2.

3.0 Zone A Material Placement

- .1 The Zone A material shall be placed as bedding for the liner system (minimum 300 mm thick) to the design grade specified in the Construction Drawings.
- .2 Subsequent to the liner installation, the Zone A material shall be placed as liner system cover material. The liner system cover material shall be placed to the minimum thickness specified in Table 1004.1 dependent on the type of liner selected.

Material	Minimum Thickness (m)
Enviro Liner® 4040 (Without Geocomposite)	1.3 m
Enviro Liner® 4040 (With Geocomposite)	0.3 m
HDPE 60	0.3 m
PVC 40 (With Geocomposite)	0.3 m

- .3 The Construction Drawings are based on the selection of Enviro Liner® 4040 with the installation of a geocomposite reinforcing material. Other design alternatives are detailed in Section 1007.
- .4 Zone A material shall be placed in lifts not exceeding 300 mm in uncompacted thickness. Vehicle traffic is prohibited from maneuvering within the Facility until the cover material has reached the minimum thickness required as specified in Table 1004.1.
- .5 Moisture condition and compact with using the minimum number of passes established in accordance with section 1006.4.1.
- .6 Equipment with ground pressures higher than 380 kPa should not be permitted inside the Facility once the liner system has been placed. Care is required to provide the appropriate thickness of fill beneath a vehicle when placing material above the liner system to ensure it is not damaged. Traffic in the area should be restricted to low ground pressure equipment.

END OF SECTION



Section 1005

□ □ □ □ □ □ □ □ M



- i. ASTM D4833 Standard Test Methods for Index Puncture Resistance for Geotextile, Geomembranes, and Related Products.
 - j. ASTM D5199 Standard Test Methods for Measuring the Nominal Thickness of Geosynthetics.
 - k. ASTM D5261 Standard Test Methods for Measuring Mass per Unit Area of Geotextiles.
 - l. ASTM D5994 Standard Test Methods for Measuring Core Thickness of textured Geomembranes
- .2 Federal Test Method
- a. FTM Standard 101.

3.0 Materials

.1 Geotextile

- a. The non-woven geotextile shall have a weight of 542 g/m². The manufacturer shall, prior to shipment of materials, provide to the Engineer a signed manufacturing certification that materials to be shipped to site have test values that meet or exceed the requirements listed in Table 1005.1.

TABLE 1005.1 MINIMUM TEST VALUES FOR NON-WOVEN GEOTEXTILE	
TEST METHOD	MINIMUM VALUE
Thickness – Typical (ASTM D5199)	3.6 mm
Grab Tensile Strength (ASTM D4632)	1690 N
Elongation at Failure (ASTM D4632)	50 %
Trapezoidal Tear Strength (ASTM D4533)	645 N
Puncture (ASTM D4833)	1070 N
Apparent Opening Size (ASTM D4751)	150 microns
Weight – Typical (ASTM D5261)	542 g/m ²

□
 □

- b. Any visible damage to the shipment of geotextile shall be noted on the freight receipt and project records.
- c. Storage of geotextile rolls on site shall be in a secure location that will minimize exposure to the elements, UV light and physical damage.

.2 Enviro Liner® 4040

- a. The Enviro Liner® shall be 1.0 mm (40 mil) thick geomembrane or equivalent. The manufacturer shall, prior to shipment of materials, provide to the Engineer a signed manufacturing certification that materials to be shipped to site have test values that meet or exceed the requirements listed in Table 1005.2.

Minimum Average Thickness (ASTM D5994)	1.0 mm
Relative Density (ASTM D792)	0.939
Tensile Strength at Yield (ASTM D638)	26.6 N/mm
Elongation at Yield (ASTM D638)	800 %
Tear Resistance (ASTM D1004)	98 N
Puncture Resistance (FTMS 101)	271 N
Carbon Black Content (ASTM D1603)	2.0 – 3.0 %

- b. The liner material supplied under the specifications shall not have any blisters, holes, undispersed raw materials or any signs of contamination or inclusions of foreign matter. Such defects shall be repaired using techniques in accordance with manufacturer’s recommendations. Excessive defects may be grounds for rejecting the entire roll of liner.
- c. Storage of geomembrane rolls on site shall be in a secure location that will minimize exposure to the elements and physical damage.
- d. Enviro Liner® geomembrane is suitable for secondary containment of hydrocarbons and other chemicals, and primary containment of water and water based effluents or as approved by manufacturer.

.3 HDPE Liner

- a. The HDPE geomembrane shall be 1.5 mm (60 mil) thick geomembrane or equivalent. The manufacturer shall, prior to shipment of materials, provide to the Engineer a signed manufacturing certification that materials to be shipped to site have test values that meet or exceed the requirements listed in Table 1005.3.

Property	Requirement
Minimum Average Thickness (ASTM D5994)	1.5 mm
Relative Density (ASTM D792)	0.94
Tensile Strength at Yield (ASTM D638)	22.0 kN/m
Elongation at Yield (ASTM D638)	12 %
Tear Resistance (ASTM D1004)	187 N
Puncture Resistance (FTMS 101)	480 N
Carbon Black Content (ASTM D1603)	2.0 – 3.0 %

- b. The liner material supplied under the specifications shall not have any blisters, holes, undispersed raw materials or any signs of contamination or inclusions of foreign matter. Such defects shall be repaired using welding techniques in accordance with manufacturer’s recommendations. Excessive defects may be grounds for rejecting the entire roll of liner.
- c. Extrusion resin used for extrusion joining of sheets and for repairs should be HDPE from the same resin batch as the sheet resin. Physical properties must be the same as the liner sheets.
- d. HDPE liner is suitable for containment of hydrocarbons and chemicals as well as water and water based effluents or as approved by manufacturer.
- e. Storage of geomembrane rolls on site shall be in a secure location that will minimize exposure to the elements and physical damage.

.4 PVC Liner

- a. The PVC geomembrane shall be 0.95 mm (38 mil) thick geomembrane or equivalent. The manufacturer shall, prior to shipment of materials, provide to the

Engineer a signed manufacturing certification that materials to be shipped to site have test values that meet or exceed the requirements listed in Table 1005.4.

	5.4
Minimum Average Thickness (ASTM D5994)	0.95 mm
Tensile Strength at Yield (ASTM D638)	17 N/mm
Elongation at Yield (ASTM D638)	430 %
Tear Resistance (ASTM D1004)	44 N

- b. The liner material supplied under the specifications shall not have any blisters, holes, undispersed raw materials or any signs of contamination or inclusions of foreign matter. Such defects shall be repaired using techniques in accordance with manufacturer’s recommendations. Excessive defects may be grounds for rejecting the entire roll of liner.
- c. PVC liner is suitable for containment of water and water based effluents or as approved by manufacturer. It is not suitable for containment of hydrocarbons.
- d. Storage of geomembrane rolls on site shall be in a secure location that will minimize exposure to the elements, UV light and physical damage.

.5 Geocomposite

- a. The geocomposite reinforcing material shall be 5 mm (200 mil) thick or equivalent. The manufacturer shall, prior to shipment of materials, provide to the Engineer a signed manufacturing certification that materials to be shipped to site have test values that meet or exceed the requirements listed in Table 1005.5.

	5.5
Minimum Average Thickness (ASTM D5994)	5 mm
Relative Density (ASTM D792)	0.94
Tensile Strength at Yield (ASTM D638)	79 N/cm
Puncture Resistance (FTMS 101)	489 N
Carbon Black Content (ASTM D1603)	2.0 %

- b. The geocomposite material supplied under the specifications shall not have defects or any signs of contamination or inclusions of foreign matter. Excessive defects may be grounds for rejecting the entire roll of geocomposite.

4.0 Installation - Enviro Liner® 4040 Design (with Geocomposite)

- .1 The liner system consists of the following layers (starting from the top layer):
 - Geo-Comp 5 or equivalent geocomposite
 - Enviroliner 4040 or equivalent geomembrane
- .2 The liner should line the entire surface of the Facility, which includes the crest of the berms, inside slopes, and floor. The geocomposite material is only required on the floor and approach berm of the Facility.
- .3 The Contractor shall ensure that the integrity of the liner system and its components are not compromised during construction. Precautions the Contractor may take to avoid damaging the liner system may include, but will not be limited to, providing light plants in the work area to improve visibility or using pylons to mark the lift/liner system interface.
- .4 Any damage to the liner system and/or its components shall be repaired as soon as possible. Fill placement shall cease immediately in an area where the integrity of the liner system has been compromised. Fill surrounding the damaged liner system may have to be excavated, without further damaging the integrity of the liner, to permit repairs to be made. Hand excavation shall be used to expose damaged portions of the liner for repair.
- .5 The liner system shall be anchored at the top of the berm so that movement downslope does not occur during backfilling at any stage of construction.
- .6 The Contractor shall take the necessary steps to ensure that backfilling does not induce tensile stress in the liner system. Care shall be taken to avoid making sharp turns, sudden stops or sudden starts adjacent to the liner system. Non-essential heavy equipment traffic in the immediate vicinity of the liner system shall not be permitted.

Enviro Liner® Installation

- .7 The Enviro Liner® should be deployed subsequent to the placement of Zone A bedding material.

avoid damaging the liner system may include, but will not be limited to, providing light plants in the work area to improve visibility or using pylons to mark the lift/liner system interface.

- .4 Any damage to the liner system and/or its components shall be repaired as soon as possible. Fill placement shall cease immediately in an area where the integrity of the liner system has been compromised. Fill surrounding the damaged liner system may have to be excavated, without further damaging the integrity of the liner, to permit repairs to be made. Hand excavation shall be used to expose damaged portions of the liner for repair.
- .5 The liner system shall be anchored at the top of the berm so that movement downslope does not occur during backfilling at any stage of construction.
- .6 The Contractor shall take the necessary steps to ensure that backfilling does not induce tensile stress in the liner system. Care shall be taken to avoid making sharp turns, sudden stops or sudden starts adjacent to the liner system. Non-essential heavy equipment traffic in the immediate vicinity of the liner system shall not be permitted.

HDPE Liner Installation

- .7 The HDPE liner should be deployed subsequent to the placement of Zone A bedding material. The liner should be placed with no horizontal seams on the slopes. Tie-in seams should be located on the floor at a minimum of 1.5 m from the toe of the slopes.
- .8 The liner panels shall be welded together along the full length of the seam to the top of the berm.
- .9 Both the wedge and the extrusion welding equipment should be qualified by conducting trial seam tests prior to start-up each day and at approximately 4-hour intervals during seaming operations. During the trial seam, the minimum peel and shear strength criteria set by the manufacturer for the 60 mil HDPE geomembrane should be met. The industry-accepted peel and shear strengths for 60 mil HDPE geomembrane are 78 ppi (pounds/inch) and 120 ppi, respectively.
- .10 The Engineer should walk the liner to observe for any defects caused by on-site equipment and tools. Any liner area showing injury due to excessive scuffing, puncture, or distress from any cause should be replaced or repaired with an additional



piece of HDPE liner extrusion welded over the defective area. All patches should have rounded edges and extend a minimum of 150 mm beyond the affected area.

- .11 Low ground pressure equipment should be used to deploy the liner material. No track-wheel equipment shall be allowed on the liner. Equipment travel on the liner material should be kept to a minimum.

Material Quantities

- .12 Estimated material quantities required for the lined pad are listed in Table 1005.7

5M	M
M r	r
HDPE 60 Liner	1900

6.0 Installation - PVC 40 Design

- .1 The liner system consists of the following layers (starting from the top layer):
 - Geo-Comp 5 or equivalent geocomposite
 - PVC 40 mil or equivalent geomembrane
- .2 The liner system should line the entire surface of the Facility, which includes the crest of the berms, inside slopes, and floor. The geocomposite material is only required on the floor and approach berm of the Facility.
- .3 The Contractor shall ensure that the integrity of the liner system and its components are not compromised during construction. Precautions the Contractor may take to avoid damaging the liner system may include, but will not be limited to, providing light plants in the work area to improve visibility or using pylons to mark the lift/liner system interface.
- .4 Any damage to the liner system and/or its components shall be repaired as soon as possible. Fill placement shall cease immediately in an area where the integrity of the liner system has been compromised. Fill surrounding the damaged liner system may have to be excavated, without further damaging the integrity of the liner, to permit repairs to be made. Hand excavation shall be used to expose damaged portions of the liner for repair.



Material Quantities

.12 Estimated material quantities required for the lined pad are listed in Table 1005.8

Material	Quantity
PVC 40 Liner	1900
Geo-Comp 5	905

END OF SECTION

Particle Size Analysis	One (1) test every 500 m ³ during construction.
------------------------	--

.2 Zone B Material

- a. Samples of the Zone B material will be evaluated from the foundation material within the Facility prior to construction and every 2000 m³ placed during construction to ensure the placed gradation meets the specification stated herein. The required tests and testing frequency for the Zone B material are presented in Table 1006.2.

Particle Size Analysis	One (1) location within the Facility and One (1) test every 2000 m ³ during construction.
------------------------	--

4.0 Fill Compaction Testing Requirements

.1 Zone A Material

- a. Compact each lift with a minimum of six passes using a large smooth-drum, vibratory compactor. The optimum vibratory frequency and number of passes should be determined during construction using proof-roll tests, which demonstrate optimum compaction. The Engineer should inspect the compaction effort to ensure that this effort results in a density equivalent to about 95% MDD.

.2 Zone B Material

- a. Compact each lift with a minimum of six passes using a large smooth-drum, vibratory compactor. The optimum vibratory frequency and number of passes should be determined during construction using proof-roll tests, which demonstrate optimum compaction. The Engineer should inspect the compaction effort to ensure that this effort results in a density equivalent to about 98% MDD.
- b. The foundation material (Zone B or subcut material) should also be compacted as specified in section 1006.4.1.

5.0 Geomembrane Testing Requirements

.1 General

- a. The Contractor is responsible for obtaining mill certificates from the manufacturer and forwarding them to the Engineer.
- b. If applicable, the Contractor shall record all seam parameters (i.e. time, date, operator, welding speed and temperature) on the liner.
- c. If applicable, the Contractor shall be responsible for completing the vacuum box testing and pressure testing for the appropriate seams. The Contractor shall mark the test number and parameters on the liner.
- d. If applicable, the Contractor shall supply and use a field tensiometer for testing liner seams for shear and peel strength.
- e. The Contractor is responsible for maintaining testing records.
- f. All coupons and test specimens remain the property of the Owner.

.2 Qualifying Welds

- a. Qualifying seams shall be conducted on fragmented pieces of material at the following times:
 - At the start of each shift of production seaming, and at 4 hour intervals during production seaming;
 - When a new operator or new machine starts welding;
 - When a machine is restarted after repairs;
 - When welding is stopped for sixty (60) minutes or more;
 - When there is a change in the ambient conditions; and
 - At the discretion of the Engineer.
- b. Qualifying seams shall be 1 m long, and shall be subject to shear and peel testing. The test seam shall meet the minimum requirements stated herein for seam strength, when tested on a field tensiometer. If a qualifying seam fails, the seaming procedure shall be reviewed and the test shall be repeated.

.3 Non-Destructive Testing

- a. Test all wedge-welded seams over their full length using a vacuum unit or air pressure test.
 - Seam intersections will also be subject to vacuum box testing, regardless of seaming method employed.
 - The Contractor shall supply all apparatus and personnel for this type of test.
 - The tests shall be witnessed and documented by the Engineer.
- b. Clean all seams to permit proper inspection.
- c. Repair any seams which fail non-destructive testing in accordance with this Specification. Repairs shall be fully documented by the Contractor.

.4 Vacuum Box Testing

- a. Extrusion welded seams should be tested using either vacuum box testing or pick-testing. Vacuum box testing involves placing the extrusion weld under a vacuum. The weld is first coated with a soapy water solution and any holes in a weld would be indicated by a stream of bubbles when vacuum is applied.
- b. No leaks shall be permitted while conducting vacuum box testing.
- c. Pick-testing is conducted on uneven surfaces where a vacuum cannot be maintained. During pick testing, attention should be paid to the following specific items:
 - The width of the weld;
 - Weld bond to the underlying geomembrane;
 - Joints between three panels (“T” joints);
 - Defects such as bubbles created within the weld due to moisture; and
 - Textured weld surfaces due to temperature fluctuation in the extrusion welder.

.5 Air Pressure Testing

- a. Wedge welded seams should be air-pressure tested over their full lengths using an air pressure test. Air pressure testing involves pressurizing the air channel located between the dual tracks of the seams to a minimum pressure of 40 psi for a period of five minutes.
- b. During the test, the air pressure is not allowed to drop more than 4 psi (10% allowance). Any leaks and bubbling in the seams found during the non-destructive tests must be repaired by extruding a patch of HDPE material over the defect.
- c. Air pressure testing shall be carried out according to GRI Test Method GM6, Pressurized Air Channel Test for Dual Seamed Geomembranes.

.6 Destructive Testing for Production Seams

- a. Cut-out coupons shall be taken at a minimum frequency of one (1) per 150 m of seam, or once per seam. Coupons shall be cut by the contractor at the location directed by the Engineer. Coupons shall generally be taken from a location that does not affect the performance of the liner. All cut-outs shall have rounded corners. Care shall be taken to ensure that no slits penetrate the parent liner.
- b. All holes left by cut outs shall be patched immediately.

.7 Testing of Repairs

- a. All repairs shall be tested using the Vacuum Box in accordance with test method ASTM 4437.

END OF SECTION



Section 1007



3.0 Detailed Design Alternatives – Non-Compliance Criteria II

- .1 If the fill materials do not comply with gradation specifications as per Table 1007.1 geotextile material is required above and below the liner system.
- .2 The geotextile material should be deployed prior to the deployment of the liner system as well as subsequent to the deployment of the liner system.
- .3 The geotextile should be placed with a minimum overlap of 150 mm and connected at the seam by heat bonding. If heat bonding is not available an overlap of 300 mm should be used. Horizontal seams should be kept to a minimum on the side slopes. If a horizontal seam is unavoidable, the overlap shall be capped with a 300 mm wide strip of the same geotextile and heat bonded to the underlying material.
- .4 Any tears or holes made in the geotextile should be repaired by placing a patch of geotextile on the defect and held in place by heat bonding. The patch should extend at least 300 mm beyond the damage, in all directions.

4.0 Detailed Design Alternatives – Non-Compliance Criteria III

- .1 If the fill materials do not comply with gradation specifications as per Table 1007.1 geotextile material is required above and below the liner system as well as at the interface between Zone A and Zone B materials.
- .2 The geotextile material should be placed prior to the placing of Zone A material, prior to the deployment of the liner system as well as subsequent to the deployment of the liner system.
- .3 The geotextile should be placed with a minimum overlap of 150 mm and connected at the seam by heat bonding. If heat bonding is not available an overlap of 300 mm should be used. Horizontal seams should be kept to a minimum on the side slopes. If a horizontal seam is unavoidable, the overlap shall be capped with a 300 mm wide strip of the same geotextile and heat bonded to the underlying material.
- .4 Any tears or holes made in the geotextile should be repaired by placing a patch of geotextile on the defect and held in place by heat bonding. The patch should extend at least 300 mm beyond the damage, in all directions.

END OF SECTION



Section 1008



5.0 General

- .1 This section provides a general guideline for the operation and maintenance of the Waste Containment Facility.

6.0 Geomembrane Lined Pad

- .1 Structure Maintenance
 - a. This section refers to the structure as the berm, side slopes, and floor of the Facility.
 - b. The structure shall be inspected regularly. Attention shall be concentrated on the following:
 - Eroded and/or damaged granular slope and floor surfaces and
 - Exposed liner material
 - c. Any identified problems should be repaired immediately. The repair can be conducted by reconstructing the damaged or eroded slopes with a material of similar gradation to Zone A material. Any exposed liner material can be recovered with Zone A material; however, if the liner material is damaged, liner installation personnel shall be retained to repair the liner.
- .2 Surface Water Management
 - a. The Facility is designed to drain all surface water to the installed vertical culvert. Each month, the water level must be inspected, pumped and disposed of appropriately.
 - b. The frequency of monitoring must be increased during times of high precipitation or snow melt within the Facility.

7.0 Filling Procedure

- .1 The filling procedure for the Facility is as follows:
 - a. Waste material is not to exceed a height of 3.0 m above the level of the top of the berm unless approved by the Engineer;
 - b. Waste material is not to be placed higher than relative elevation 0.5 m below the crest of the liner unless approved by the Engineer.



8.0 Closure

- .1 Upon reaching capacity the Facility will be capped with material meeting the specifications outlined in Table 1008.1 or as approved by the Engineer.

TABLE 1008.1 CAPPING MATERIAL SPECIFICATIONS		
Minimum Thickness (m)	Minimum Organic Content (%)	Minimum Water Content (%)
100	100	100
50	95	100
25	90	100
20	85	100
5	65	90
0.63	35	60
0.08	5	20

- .2 The capping material shall have a minimum thickness of 0.5 m.
- .3 The vegetative cover must be capable of self-regeneration without continuous dependence on fertilizer or re-seeding.
- .4 The vegetative cover must have sufficient density and species diversity to stabilize the surface against the effects of long term erosion.
- .5 Closure monitoring should include inspection for any ponding water. If ponded water is present capping material should be added or re-graded.

END OF SECTION

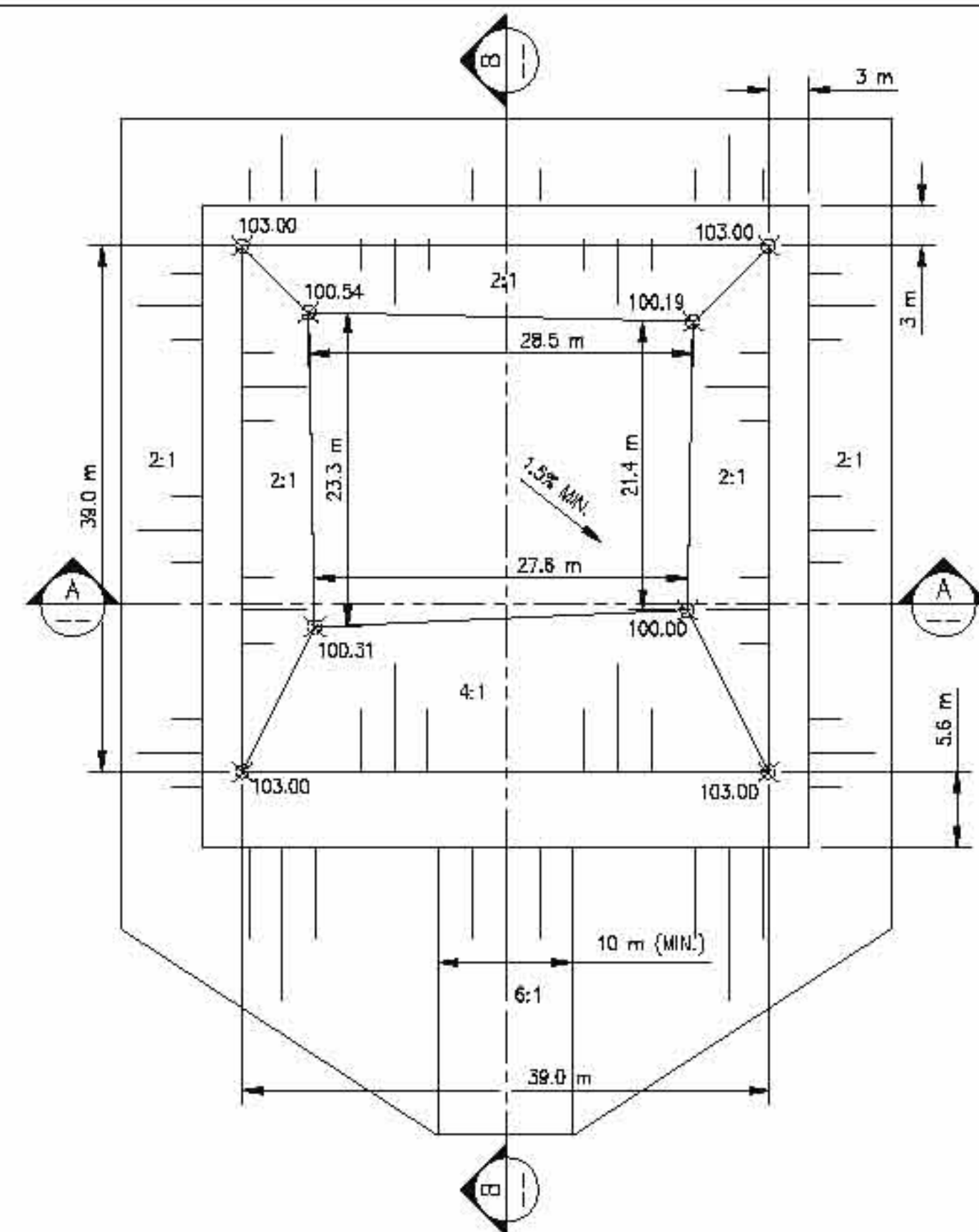

PLAN - ZONE B MATERIAL
SCALE 1 : 400

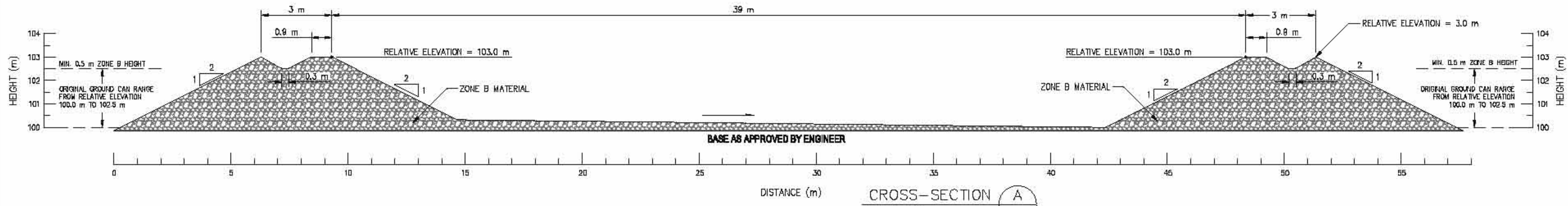

CROSS-SECTION A
SCALE 1 : 100

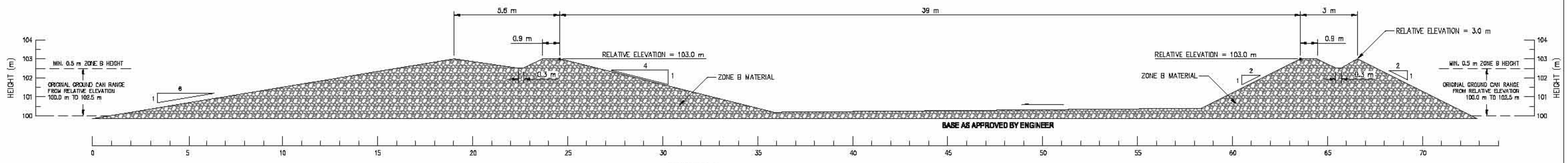

CROSS-SECTION B
SCALE 1 : 100

ISSUED FOR CONSTRUCTION

NOTES

1. CONTAINMENT FACILITY SIZED FOR 1000 m³ OF GEOMEMBRANE. CONFIGURATION OF BASE AREA CAN BE MODIFIED SHOULD SITE CONDITIONS WARRANT. HOWEVER, SPECIFIED BERM CROSS-SECTION, FILL MATERIALS, LINER SYSTEM AND GENERAL DESIGN CRITERIA MUST BE ADHERED TO.
2. SPECIFIC CONDITIONS AND FACILITY LOCATION HAVE NOT BEEN PROVIDED OR CONSIDERED. ONCE FACILITY LOCATION AND SITE SPECIFIC CONDITIONS ARE KNOWN, THEY MUST BE APPROVED BY THE ENGINEER PRIOR TO CONSTRUCTION.
3. ALL ELEVATIONS ON PLAN ARE FOR TOP OF ZONE B MATERIAL.

NUM	DATE	DWN	CKD	APR	DESCRIPTION
B	06/07/08	JPS			ISSUED FOR CONSTRUCTION
A	06/09/08	JPS			ISSUED FOR REVIEW
		APR			DESCRIPTION

ORIGINAL
SIGNED AND SEALED

Permit: J. Richard Trinkle, P.Eng. Date: July 8, 2008
Seal: Jason Barkers, P.Eng. Date: July 9, 2008

The signed Professional Seal and Permit to Practice
source reside on the associated drawing which is held
and controlled by EBA Engineering Consultants Ltd.

PERMIT

PROFESSIONAL SEAL



EBA Engineering
Consultants Ltd. eba

TYPICAL WASTE CONTAINMENT FACILITY DESIGN
KENO HILL, SILVER DISTRICT, YT

ZONE B MATERIAL PLAN & CROSS SECTIONS

PROJECT NO.	OFFICE	DESIGNER	CHECKED	REVISED	DRAWN
W1410142	WHSE	JTP	JPS	0	
DATE	SHEET NO.	DRAWN	APP	BY/DATE	
June 26, 2008	1 of 4	KJT	JRT	B	

WCF-1

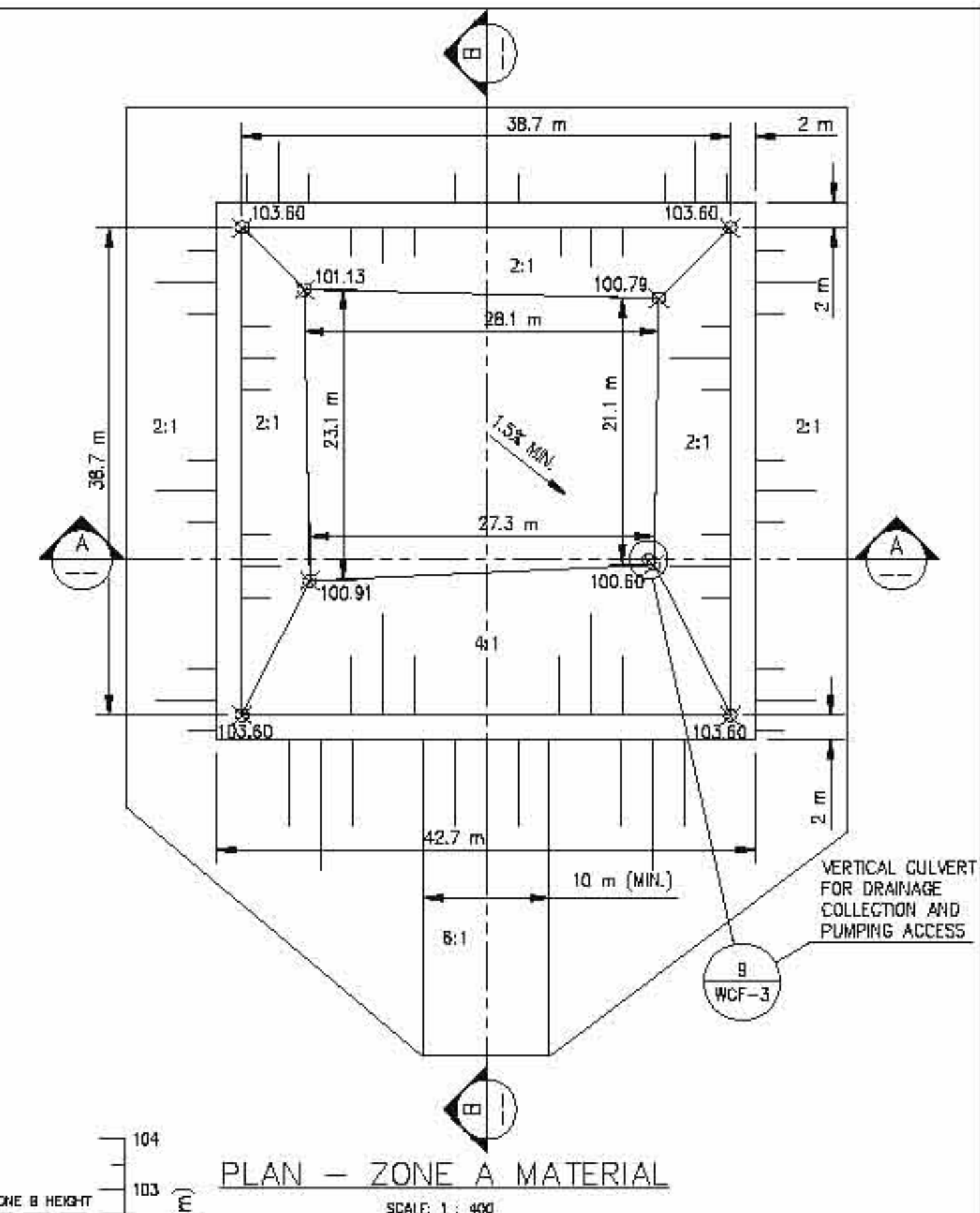

PLAN - ZONE A MATERIAL
SCALE: 1 : 400

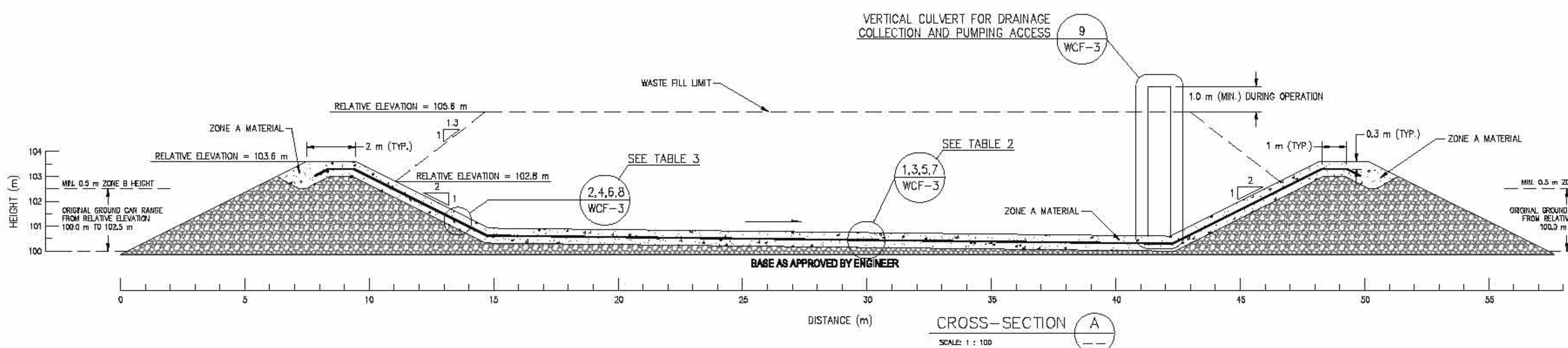

CROSS-SECTION A
SCALE: 1 : 100

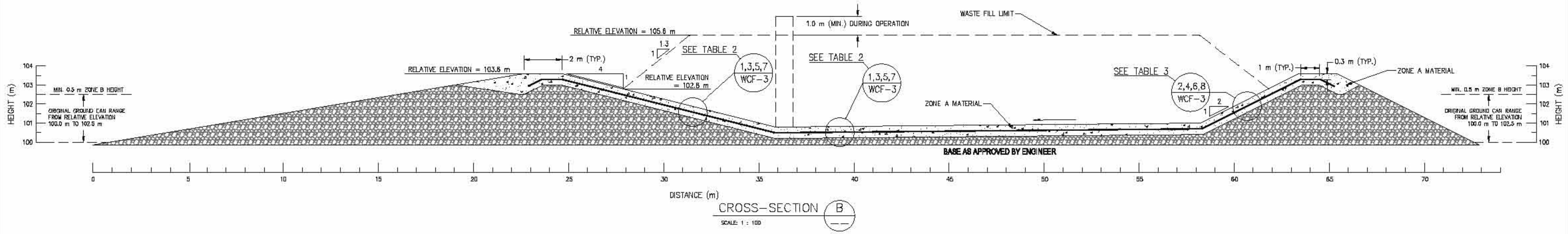

CROSS-SECTION B
SCALE: 1 : 100

ISSUED FOR CONSTRUCTION

- NOTES**
1. CONTAINMENT FACILITY SIZED FOR 1000 m² OF GEOMEMBRANE. CONFIGURATION OF BASE AREA CAN BE MODIFIED SHOULD SITE CONDITIONS WARRANT. HOWEVER, SPECIFIED BERM CROSS-SECTION, FILL MATERIALS, LINER SYSTEMS AND GENERAL DESIGN CRITERIA MUST BE ADHERED TO.
 2. SPECIFIC CONDITIONS AND FACILITY LOCATION HAVE NOT BEEN PROVIDED OR CONSIDERED. ONCE FACILITY LOCATION AND SITE SPECIFIC CONDITIONS ARE KNOWN, THEY MUST BE APPROVED BY THE ENGINEER PRIOR TO CONSTRUCTION.
 3. ALL ELEVATIONS ON PLAN ARE FOR TOP OF ZONE A MATERIAL.

NUM	DATE	DWN	CKD	APR	DESCRIPTION
B	08/07/08	JPS			ISSUED FOR CONSTRUCTION
A	08/02/08	JPS			ISSUED FOR REVIEW
		APR			DESCRIPTION

ORIGINAL SIGNED AND SEALED

Permit: J. Richard Trinkle, P.Eng. Date: July 8, 2008
 Seal: Jason Barkers, P.Eng. Date: July 8, 2008

The signed Professional Seal and Permit to Practice (where applicable) are on the associated drawing which is held and controlled by EBA Engineering Consultants Ltd.

ALEXCO

EBA Engineering Consultants Ltd.

TYPICAL WASTE CONTAINMENT FACILITY DESIGN
KENO HILL SILVER DISTRICT, YT

ZONE A MATERIAL PLAN & CROSS SECTIONS

PROJECT NO: W1410142
 OFFICE: WHSE
 DATE: June 26, 2008

DWG: JTP
 APP: KJT

REV: 0
 DATE: 08/07/08

DRAWN BY: JPS
 CHECKED BY: JRT

DATE: 08/07/08

WCF-2

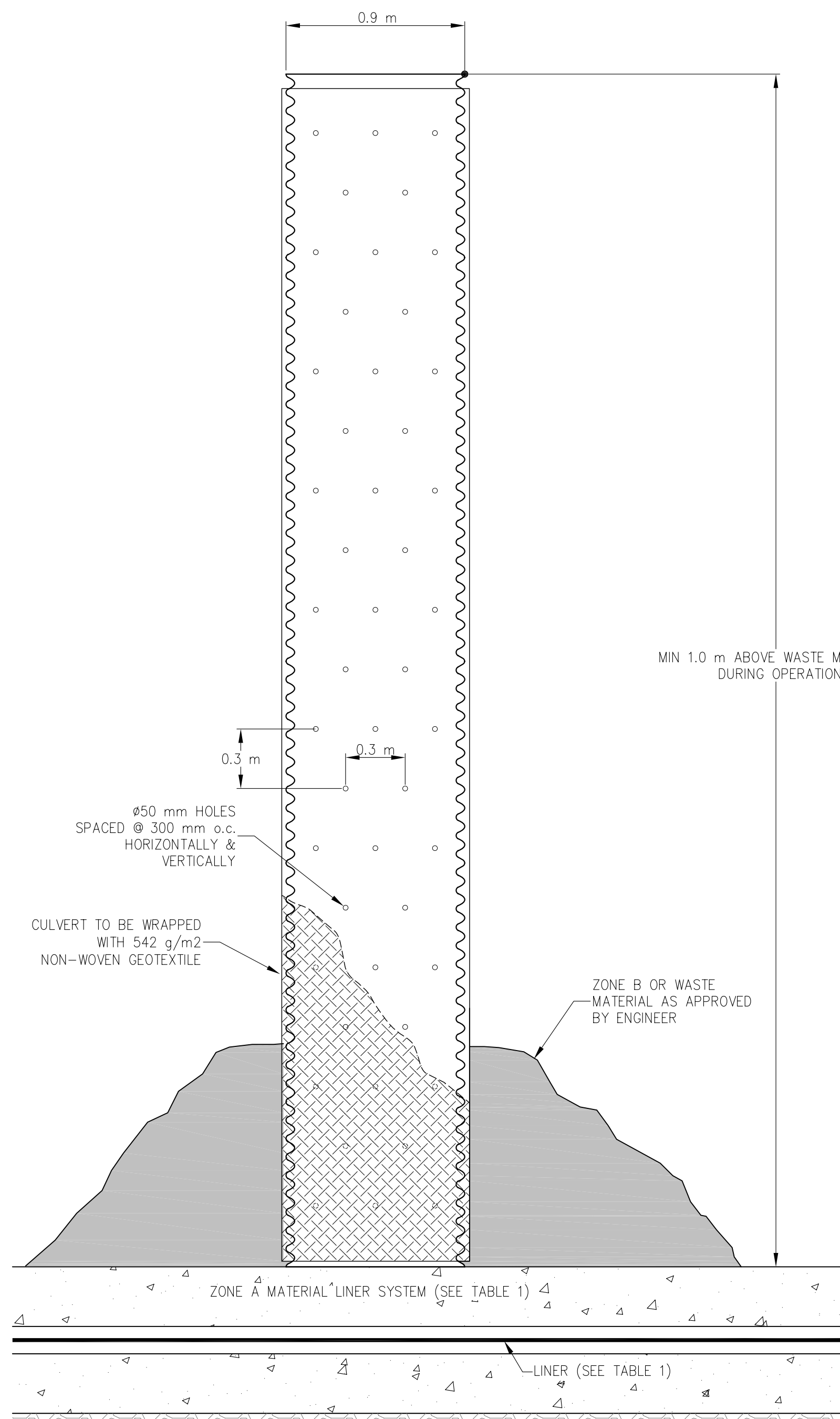

LINER SYSTEM FLOOR & APPROACH BERM

LINER SYSTEM DETAIL KEY

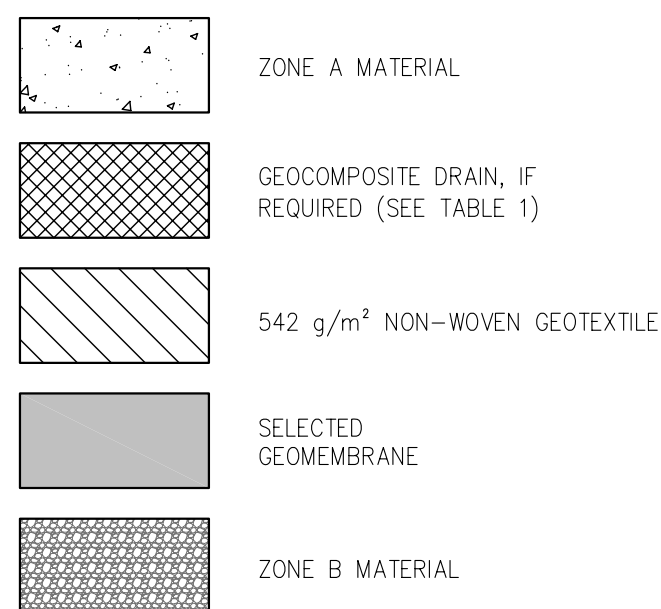

LINER SYSTEM BERMS

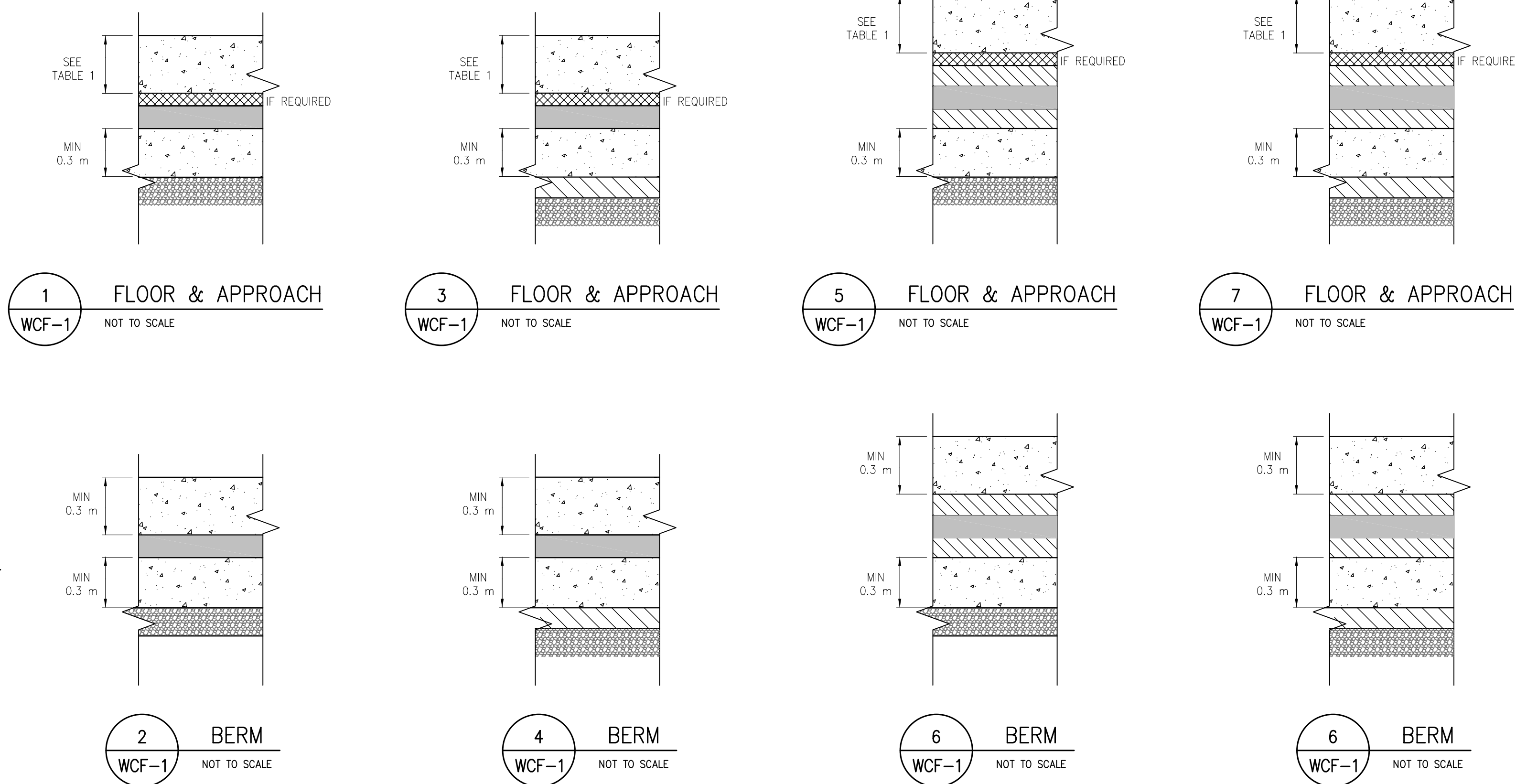

DETAIL 1 - VERTICAL CULVERT 9
SCALE: 1 : 20
WCF-1

Material	Requirement	Thickness
Enviro Liner® 4040 (Without Geocomposite)	Not Required	1.3 m
Enviro Liner® 4040 (With Geocomposite)	Required	0.3 m
HDPE 60	Not Required	0.3 m
PVC 40 (With Geocomposite)	Required	0.3 m

Detail	Detail 1	Detail 3
Detail 1	Detail 1	Detail 3
Detail 3	Detail 3	Detail 3
Detail 5	Detail 5	Detail 7

Detail	Detail 1	Detail 3
Detail 1	Detail 1	Detail 3
Detail 3	Detail 3	Detail 3
Detail 5	Detail 5	Detail 7

Detail	Detail 1	Detail 3
10	100	100
5	80	100
2	55	100
0.63	25	65
0.25	10	40
0.08	2	15

Detail	Detail 1	Detail 3
200	100	100
100	85	100
50	65	100
25	40	100
5	20	55
2	0	20

- NOTES**
- CONTAINMENT FACILITY SIZED FOR 1900 m² OF GEOMEMBRANE. CONFIGURATION OF BASE AREA CAN BE MODIFIED SHOULD SITE CONDITIONS WARRANT. HOWEVER, SPECIFIED BERM CROSS-SECTION, FILL MATERIALS, LINER SYSTEMS AND GENERAL DESIGN CRITERIA MUST BE ADHERED TO.
 - SPECIFIC CONDITIONS AND FACILITY LOCATION HAVE NOT BEEN PROVIDED OR CONSIDERED. ONCE FACILITY LOCATION AND SITE SPECIFIC CONDITIONS ARE KNOWN, THEY MUST BE APPROVED BY THE ENGINEER PRIOR TO CONSTRUCTION.

NUM	DATE	DWN	CKD	APR	DESCRIPTION
B	08/07/08	JPB			ISSUED FOR CONSTRUCTION
A	08/06/25	JPB			ISSUED FOR REVIEW

NUM	DATE	APR	DESCRIPTION
B	08/07/08	JPB	ISSUED FOR CONSTRUCTION
A	08/06/25	JPB	ISSUED FOR REVIEW

ORIGINAL SIGNED AND SEALED

Permit: J. Richard Trimble, P.Eng. Date: July 8, 2008
Seal: Jason Berkers, P.Eng. Date: July 8, 2008

The signed Professional Seal and Permit to Practice stamps reside on the executed drawing which is held and controlled by EBA Engineering Consultants Ltd.

CLIENT

EBA Engineering Consultants Ltd.

TYPICAL WASTE CONTAINMENT FACILITY DESIGN
KENO HILL SILVER DISTRICT, YT

DETAILS

PROJECT No.	OFFICE	DES	CKD	REV	DRAWING
W14101142	WHSE	JTP	JPB	0	WCF-3

DATE:	SHEET No.	DWN	APP	STATUS
JUNE 25, 2008	3 of 4	KJT	JRT	B

ISSUED FOR CONSTRUCTION

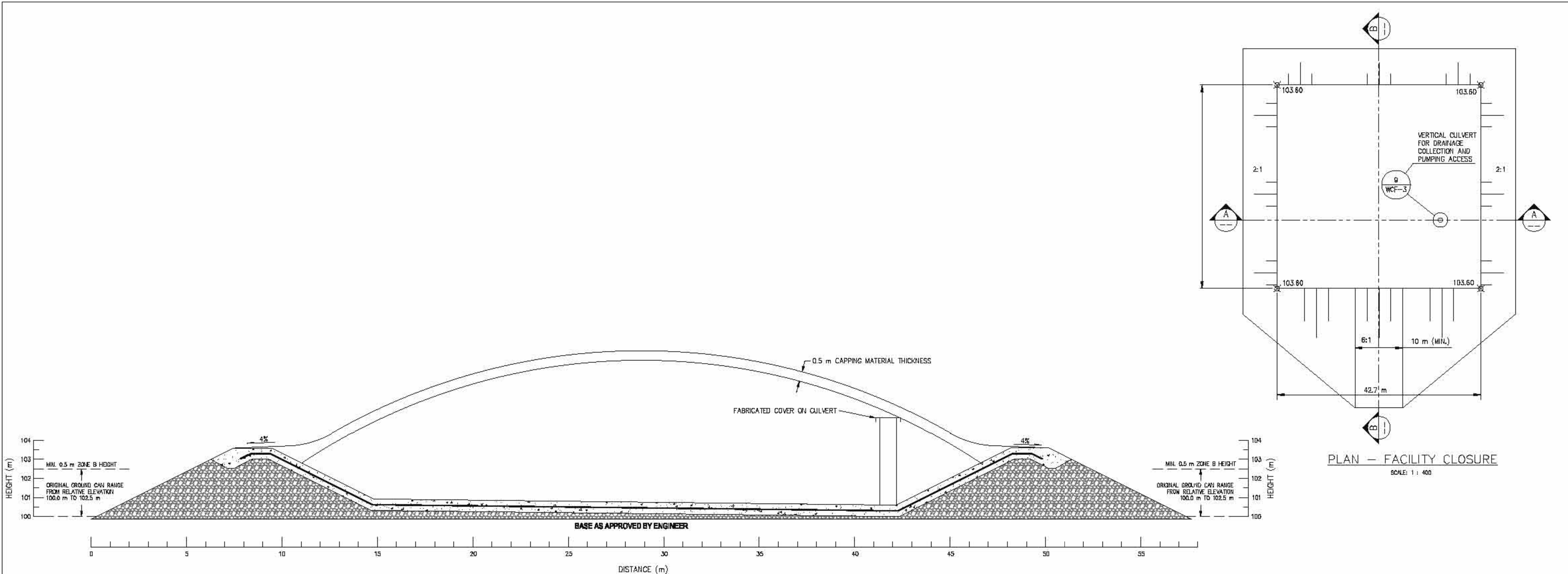

CROSS-SECTION A
SCALE: 1 : 100

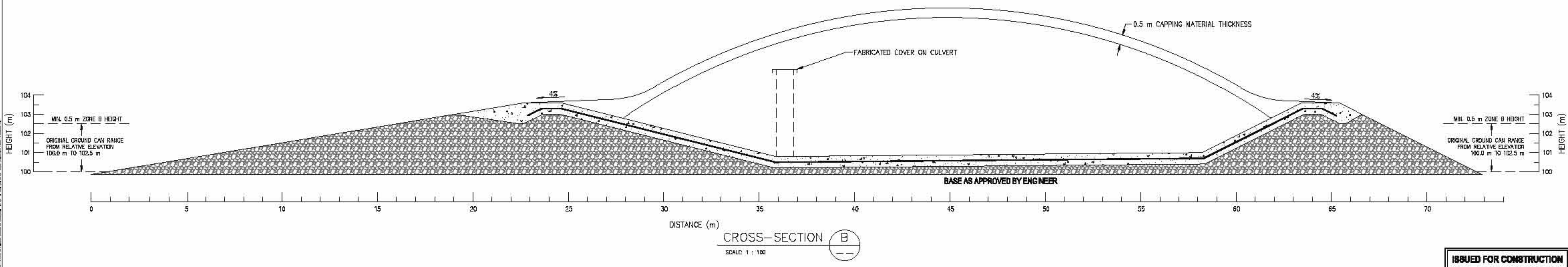

CROSS-SECTION B
SCALE: 1 : 100

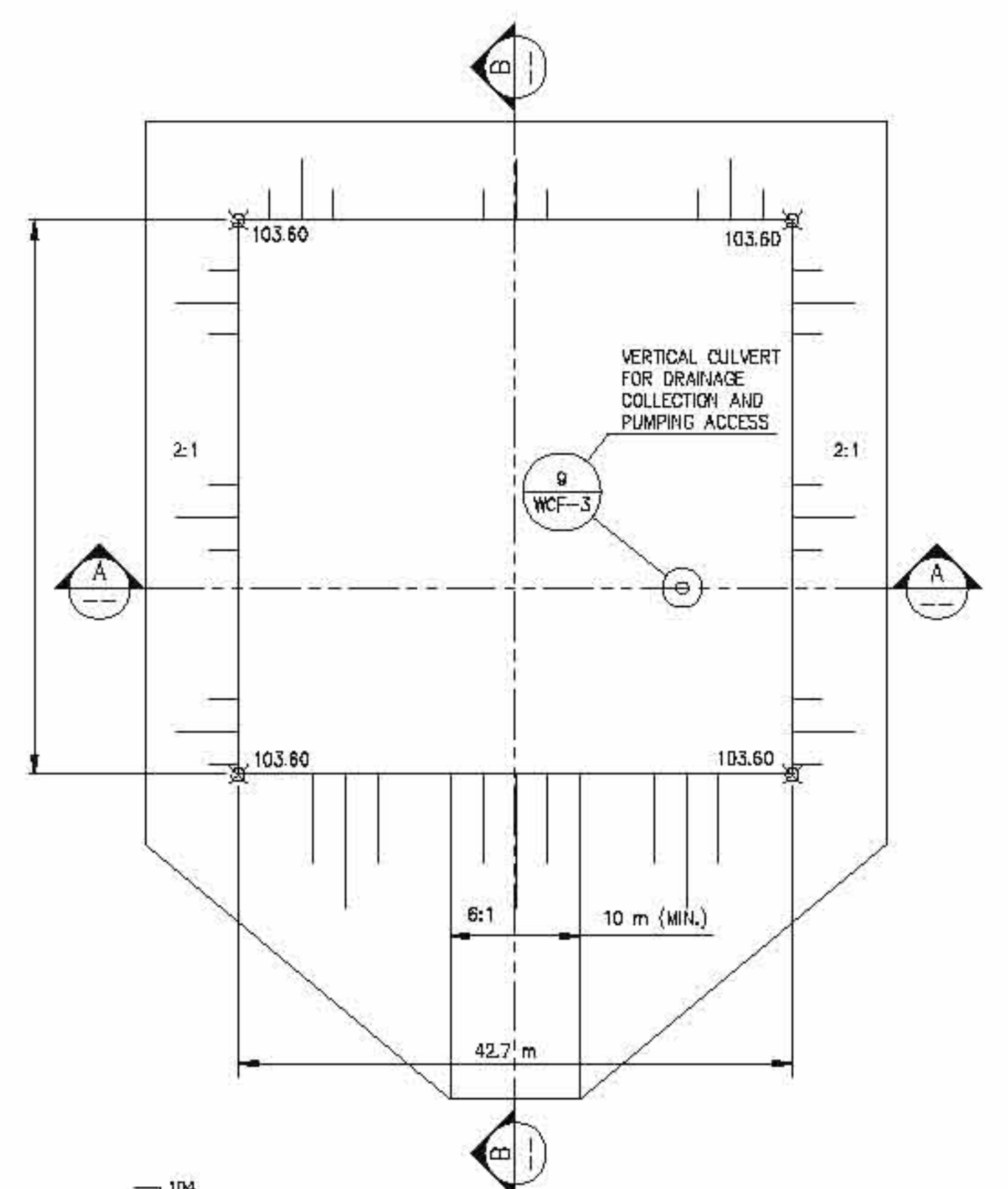

PLAN - FACILITY CLOSURE
SCALE: 1 : 400

ISSUED FOR CONSTRUCTION

- NOTES**
1. CONTAINMENT FACILITY SIZED FOR 1000 m² OF GEOMEMBRANE. CONFIGURATION OF BASE AREA CAN BE MODIFIED SHOULD SITE CONDITIONS WARRANT. HOWEVER, SPECIFIED BERM CROSS-SECTION, FILL MATERIALS, LINER SYSTEMS AND GENERAL DESIGN CRITERIA MUST BE ADHERED TO.
 2. SPECIFIC CONDITIONS AND FACILITY LOCATION HAVE NOT BEEN PROVIDED OR CONSIDERED. ONCE FACILITY LOCATION AND SITE SPECIFIC CONDITIONS ARE KNOWN, THEY MUST BE APPROVED BY THE ENGINEER PRIOR TO CONSTRUCTION.

NUM	DATE	DWN	CKD	APR	DESCRIPTION
2	08/07/08	JPS			ISSUED FOR CONSTRUCTION
1	08/06/08	JPS			ISSUED FOR REVIEW
		APR			DESCRIPTION

ORIGINAL SIGNED AND SEALED

Permit: J. Richard Trinkle, P.Eng. Date: July 8, 2008
 Seal: Jason Barkers, P.Eng. Date: July 8, 2008

The signed Professional Seal and Permit to Practice (where applicable) are the associated drawing which is held and controlled by EBA Engineering Consultants Ltd.

ALEXCO

EBA Engineering Consultants Ltd.

TYPICAL WASTE CONTAINMENT FACILITY DESIGN
KENO HILL SILVER DISTRICT, YT

FACILITY CLOSURE PLAN & CROSS SECTIONS

PROJECT NO: W14101142
 OFFICE: WHSE
 DATE: June 26, 2008

DES: JTP
 DWN: KJT
 APP: JRT

REV: 0
 4 of 4

DRAWN: JPS
 CHECKED: JRT
 APPROVED: JRT

WCF-4