

Teck

2015 Geotechnical Inspection Tailings Management Facility Sä Dena Hes, Yukon Territory

Prepared for

Teck Resources Limited



Prepared by



SRK Consulting (Canada) Inc.
1CT008.053
November 2015

2015 Geotechnical Inspection Tailings Management Facility Sä Dena Hes, Yukon Territory

November 2015

Prepared for

Teck Resources Limited
601 Knighton Road
Kimberley, BC V1A 3E1
Canada

Tel: +1 250 427 8408
Web: www.teck.com

Prepared by

SRK Consulting (Canada) Inc.
2200–1066 West Hastings Street
Vancouver, BC V6E 3X2
Canada

Tel: +1 604 681 4196
Web: www.srk.com

Project No: 1CT008.053

File Name: 2015_SDH_GeotInsp_Report_1CT008_053_20151130_PMH

Copyright © SRK Consulting (Canada) Inc., 2015



Table of Contents

1	Introduction	1
2	Background	1
3	Observations and Recommendations	3
3.1	North Dam.....	3
3.1.1	Observations	3
3.2	North Creek Dyke and Second Crossing.....	5
3.2.1	Observations	5
3.2.2	Recommendations	5
3.3	Sediment Retaining Structure (South Dam)	6
3.3.1	Observations	6
3.3.2	Recommendations	6
3.4	Reclaim Dam	6
3.5	Drainage Channels	6
3.5.1	Observations	6
3.5.2	Recommendations	7
3.6	Burnick and Jewelbox Waste Rock Dumps.....	7
3.6.1	Observations	7
3.6.2	Recommendations	7
4	Inspections	7
4.1	Dam Safety Inspections (DSI)	7
4.2	Dam Safety Review (DSR) and Operations, Maintenance and Surveillance (OMS) Manual	8
4.3	Emergency Preparedness	8

List of Figures

- Figure 1: Vicinity Map
- Figure 2: TMA General Arrangement Map
- Figure 3: North Dam Site Plan
- Figure 4: Section 0+400 North Dam
- Figure 5: Sediment Retaining Structure Location Map
- Figure 6: Sediment Retaining Structure – Plan and Profiles
- Figure 7: Drainage Channel Plan View
- Figure 8: Burnick Zone Plan View
- Figure 9: Plan View of the Main Zone and Jewelbox Dumps

List of Tables

- Table 3.1: Summary of Survey Results for North Dam Settlement Gauges..... 4

Appendices

- Appendix A: Photo Log
- Appendix B: Piezometric Levels

1 Introduction

In accordance with an authorization by Mr. Gerry Murdoch, Teck Resources Limited, Mr. Peter Healey of SRK Consulting (Canada) Inc. completed a geotechnical inspection of structures and features associated with the Tailings Management Area (TMA) that would form part of the closed Sä Dena Hes mine located near Watson Lake, Yukon. The inspection was carried out on June 16, 2015. This report presents our observations of the following structures and features and provides recommendations where appropriate:

- The North Dam;
- The decommissioned North Creek Dyke and Second Crossing;
- The relocated Camp Creek Channel;
- The North Channel;
- The Sediment Retaining Structure; and
- The Burnick Waste Rock Dump below the 1200 Portal.

The weather during both inspections was mild and sunny. It should be noted that all elevations referenced in this report are based on a datum that was established during a LiDar survey carried out in 2012. The original site datum used to design and build the structures in the early 90's was about 2 m lower than the 2012 datum. All previous inspection reports, prior to 2014, used the 1990 datum.

A map showing the overall mine site is provided on Figure 1. The general arrangement map of the TMA is provided in Figure 2. Photo 1 shows a view west over the entire mine site.

2 Background

The original TMA which extended from the North Dam to the South Dam covered an area of approximately 0.205 sq. km as shown in Figure 2. During the operating life of the mine, approximately 700,000 tonnes of tailings were deposited into the impoundment; primarily at the northern end. Between the two dams, at the location of a topographic saddle, was a 2 m high cofferdam, which had a gated culvert to control the flow of water and tailings from the northern half of the impoundment to the southern half.

The decant tower, in the South Tailings Pond, was used to discharge the supernatant water in tailings pond into the Reclaim Pond through a 0.5 m dia. corrugated steel pipe (CSP) decant pipe. During the care and maintenance period after the mine shut down in 1982, water was released from the tailings pond to the Reclaim pond seasonally by way of syphons to maintain a safe operating level. Water was discharged from the Reclaim Pond to Camp Creek in accordance with the limits imposed by the Water License.

An emergency spillway, consisting of two 900 mm diameter CSP culverts, was located on the west abutment of the South Dam. The discharge from the spillway entered the Reclaim Pond

downstream via an unlined channel. In 2003, Teck Cominco installed an HDPE pipeline, through one of the spillway culverts, as a siphon to facilitate the transfer of water from the South Tailings Pond.

An open channel emergency spillway was located at the west side of the Reclaim pond. This spillway was designed to accommodate the design flood event from the TMA catchment only. Flow through this spillway was directed to the primary spillway system which was part of the Camp Creek Diversion. This primary spillway consisted of two 1,200 mm diameter CSP culverts that was designed to accommodate the 1 in 200 year inflow design event from the catchment for Camp Creek and the TMA.

Two additional surface water diversions, the east and west interceptor ditches, were located on both sides of the TMA to intercept surface runoff from upslope of the TMA.

With 2014 decommissioning work, the TMA has been significantly modified. The Reclaim Dam was completely removed and the final excavated surface of the Reclaim Dam was graded to blend into the surrounded topography.

The Camp Creek Diversion Channel, exit chute, and culverts were decommissioned in 2015.

The interceptor ditches were decommissioned in 2015.

In 2014, most of the South Dam was removed to form the Sediment Retaining Structure (SRS). The decant tower and the pipe was decommissioned and removed to the on-site landfill. The South Dam overflow spillway was decommissioned by removing the two 900 mm diameter culverts that were disposed of at the landfill. Similar to the decommissioning of the Reclaim Dam, the dam foot print was excavated to original ground (with exception of the SRS) and blended into the surrounded topography.

Three drainage channels were built as part of the 2014 TMA decommissioning. The longest of the three was constructed through the former the Reclaim Dam and the pond area to route Camp creek flows along its historical alignment. The other two drainages (the North Channel and the South Channel) were constructed to direct runoff from the covered tailings areas to the new Camp Creek drainage channel.

A soil cover, varying up to 2.2 m in depth was placed onto areas of exposed tailings, specifically the North Tailings Area and the tailings deposited in South Pond area. The cover comprised excavated dam fill material and was used to reduce wind erosion of tailings and to provide a growth medium over the tailings for future revegetation. The cover was also intended to reduce surface water ponding and to promote runoff of non-contact water.

The total soil cover area is about 0.16 sq. km. The North Tailings Area is 0.09 sq. km, the South Pond including the grassy area is 0.03 sq. km, and the Reclaim Pond is 0.04 sq. km.

3 Observations and Recommendations

3.1 North Dam

3.1.1 Observations

A site plan of the North Dam is presented on Figure 3 and a view of the TMA looking south is shown in Photo 2.

The crest of the North Dam (Photo 6), which is at an elevation of 1100 m, shows no signs of deformation or abnormal settling. The downstream slope of the dam shows no signs of surficial movement or erosion nor is there any sign of bulging at the downstream toe.

Teck has been surveying the settlement gauges on the North Dam since 1993. Results are shown on Table 3.1. The last set of readings taken using the 1990 datum was completed in 2010. A recent set of readings was completed in 2015 based on the 2012 datum. These readings are also shown in Table 3.1. The pre-2011 results indicated that there had been no significant settlement of the embankment over the 17 year period that readings were taken. The 2015 results show a 12 to 25 mm settlement over the two month period. However, further readings would need to be taken to establish any sort of trend.

The three sets of piezometers and protective caps (Photo 7) along the crest of the North Dam remain intact. Some of the deformation monitoring pins and the original settlement gauges protected by 40-gallon drums (Photo 9) are still evident on the crest of the dam but currently serve very little purpose. Labels on each of the piezometers were recently upgraded and are weathering the elements well.

Table 3.1: Summary of Survey Results for North Dam Settlement Gauges

DATE	NDS3	NDS1	NDS2
August/93	1098.639	1098.501	1098.613
July/94	1098.637	1098.502	1098.589
August/95	1098.690	1098.545	1098.663
July/96	1098.637	1098.493	1098.609
August/97	1098.637	1098.496	1098.618
October/98	1098.627	1098.482	NA
October/02	1098.619	1098.481	1098.607
June/05	1098.637	1098.479	1098.587
June/06	1098.63	1098.45	1098.57
August/07	1098.786	1098.454	1098.489
June/08	1098.626	1098.482	1098.597
June/09	1098.625	1098.469	1098.587
June/10	1098.59	1098.47	1098.60
August/15	1100.572	1100.412	1100.524
September/15	1100.548	1100.391	1100.512

Note: 2015 readings are based on the 2012 datum.

Photos 2 and 5 show the soil cover that was placed in 2014 and 2015 in the TMA. Photo 10 indicates the depth of the cover in one location.

Along the downstream toe of the North Dam there is an 80 m long seepage zone. Seepage from this zone is collected at a monitoring station referred to as MH-02 and is a combination of groundwater discharge from the surrounding hillsides to the west and minimal seepage flow from the impoundment.

The water levels in the piezometers are recorded monthly and the 2015 data are presented in Appendix B. Figure B1 in Appendix B shows the seasonal water level fluctuation within the dam over the last two years. These levels preceded the completion of the till cover placement and reflect the water that seasonally ponded on the tailings surface during the freshet. Levels recorded in October, 2015 are plotted on the dam section shown on Figure 4. The seasonal fluctuations recorded this year in the piezometers are generally consistent with those in previous years and are within acceptable tolerance limits.

Recommendations

SRK recommends the following:

- Take water level readings from the top of the North Dam 2” diameter plastic piezometers inside the casing during the bi-monthly (every two months) site visits for the next two years. If site is considered stable, the readings would be reduced to bi-annually (twice a year) for the

- following three years and then annually for a period of five years. Water levels should not be measured from the rim of the steel casing.
- As Teck has decided to adopt the 2012 datum for the site, the conversion from depths to elevation in future should be carried out using this datum.
 - To establish trends in dam settlement annual readings of the settlement gauges on the North dam should be taken based on the new datum over the next 5 years.
 - Monitor the flow at MH-02 during the bi-monthly (every two months) site visits for the next two years. If site is considered stable, the readings would be reduced to bi-annually (twice a year) for the following three years and then annually for a period of five years.
 - The following items should be noted during any inspections:
 - Any development of erosion on the slopes
 - Any noticeable settlement of the dam crest
 - Any subsidence on the downstream slope
 - Any wet spots on the sideslopes
 - Any changes in rate, colour or turbidity in the seepage
 - Any new seeps, boils or soft areas along the toe

3.2 North Creek Dyke and Second Crossing

3.2.1 Observations

The North Creek dyke was removed in 2014 and the resulting channel was riprapped (Photo 17). Flow in the creek was conveyed through the decommissioned old dyke via a riprapped channel.

Below the North Creek Dyke is a second crossing which consisted of a single 900 mm diameter CMP culvert. There were in fact two culverts at the crossing but the lower one was permanently blocked off and was not used. However, during decommissioning work completed in 2015, both culverts were removed and replaced with a riprap lined open channel.

3.2.2 Recommendations

Annual inspections should be made of the new North Creek channel to check on the condition of the riprap armouring and for any subsidence. Any debris that may have accumulated within the channel should be removed.

The sideslopes at the channel at the second crossing in North Creek should also be inspected to ensure there is no subsidence or movement of riprap.

3.3 Sediment Retaining Structure (South Dam)

3.3.1 Observations

The South Dam was decommissioned during the 2014 and 2015 construction season by excavating and placing the fill material as a soil cover over the exposed tailings surface. Figures 5 and 6 provide a site plan and sections of the Sediment Retaining Structure (SRS).

An inspection of the structure in June 2015 noted that a small subsidence had occurred on the lower portion of the exit chute from the spillway. The material displaced was retained by the geotextile filter fabric and some of the riprap had moved. Furthermore seepage from the hillside to the east had created a channel along the downstream toe of the SRS which caused some erosion to occur at the toe of the slope adjacent to the spillway. Remedial action completed after the inspection involved constructing a riprapped channel along the downstream toe on the east side of the SRS and adding more riprap in the exit chute to stabilize the slopes. An erosion control blanket (GeoJute), a lightweight biodegradable net, was placed on the side slopes to add further erosion control (Photo 14).

During the placement of the till cover just above the SRS pond, a rock cofferdam (Figure 6 and Photos 13 and 14) was constructed to retain the movement of tailings that had liquefied as a result of the vibration caused by the earth moving machines. This cofferdam successfully stopped the slow moving tailings. Some of the excess riprap that was used to build the cofferdam was used to repair the spillway exit chute and to riprap the channel built along the downstream toe of the SRS.

3.3.2 Recommendations

An annual inspection of the spillway should be carried out to ensure the structural integrity of the dyke and the riprap erosion protection. The downstream sideslope of the SRS should be inspected for any sloughing, subsidence or bulging. The crest should also be inspected for tension cracks or settlement. The pond should be measured for depth and an assessment of silt buildup. Any sign of seepage along the downstream toe should also be noted. Any new seeps boils or soft areas at the toe of the dyke should be noted.

3.4 Reclaim Dam

The Reclaim dam has been completely removed and was not include in the scope of this inspection.

3.5 Drainage Channels

3.5.1 Observations

The new riprapped drainage channels (the North channel, the Camp Creek channel and the South channel) were constructed during the TMA decommissioning in 2014. Figure 7 provides a plan view of the three channels. SRK inspected each of the channels for any signs of subsidence and movement of the riprap erosion protection. Other than the silt build up at the toe of the exit

chute, no significant issues were noted. Photo 4 shows a northerly view of the Camp Creek and South channels.

The original Camp Creek diversion channel was decommissioned in 2015 with the removal of the two 1.2 m culverts and the 1/4 round armouring. The original ditch remains and collects seepage from the uphill catchment, directing the seepage into the adjacent bush.

3.5.2 Recommendations

It is understood that site visits by a Site Monitor would be made 2 to 3 times year. During these visits, the following items should be checked and noted for:

- Any sloughing of the diversion channel side slopes
- Any loss of the riprap erosion protection
- Any blockage of the outlets and inlets of the SRS spillway by ice and/or debris

3.6 Burnick and Jewelbox Waste Rock Dumps

3.6.1 Observations

SRK inspected the Burnick waste dump at the 1200 portal and the Main Zone and Jewelbox waste dumps (Photo 18 and 19). The locations of these dumps are shown in Figures 8 and 9. The dumps were recontoured to provide added long-term stability. No subsidence of the slopes were noted. SRK did not inspect the dump at the 1300 portal (see Figure 8) because of restricted access.

3.6.2 Recommendations

SRK recommends that Teck continue to make annual inspections of Burnick 1200 dump slope, the dumps at Jewelbox and the Main Zone for any sign of vertical settlements, displacements or bulging.

4 Inspections

4.1 Dam Safety Inspections (DSI)

Teck shall ensure that an annual inspection of the mine site be carried out by a qualified geotechnical engineer. The focus of the inspections would be the North Dam, the Sediment retaining structure (SRS) and spillway, soil covers, diversions and waste rock dumps. The findings of the inspection should be formalized in a report, which includes an evaluation of the annually measured piezometer levels and settlement readings at the North Dam. The inspection should take place as soon as possible after the snow has melted. This would allow any necessary remedial work to be completed prior to the rainy season.

Extra-ordinary inspections should be carried out after any significant storm or seismic events. The triggers for these inspections would be any unusually high intensity rainfall events or high runoff events that are observed in Watson Lake and/or a seismic event equivalent to a Modified Mercalli Intensity scale of IV (Moderate) as felt in Watson Lake.

Over the first five-year period following closure, the annual inspection should be carried out by a qualified professional engineer. After five years, the annual inspection should be carried out by an appropriate representative of the owner responsible for the safety of the tailings storage facility, supplemented by inspections every five years by a qualified professional engineer.

A report would be prepared after each inspection.

4.2 Dam Safety Review (DSR) and Operations, Maintenance and Surveillance (OMS) Manual

The last DSR was carried out in 2009 by Golder Associates. At time this inspection report was written, a DSR was in progress by AMEC and a draft OMS manual prepared by SRK was submitted to Teck. In accordance with the CDA guidelines, a DSR is not required for low consequence dams. The recent dam breach analysis conducted on the North Dam concluded that it would be a low consequence dam and as such no future DSR's would be required. However, the consequence of failure should be reviewed periodically to ensure there has been no change to the downstream condition. The OMS manual is considered a living document and would be revised or updated as required.

4.3 Emergency Preparedness

The last Emergency and Response Plan (ERP) was prepared by SRK as part of the 2004 OMS. The plan was directed mainly at the tailings management facility including the three dams, the spillways and the diversion ditches. A recent ERP was prepared as part of the OMS manual and focused on the decommissioned site. Similarly to the OMS manual, the ERP would be revised or updated as required.

This report, 2015 Sä Dena Hes Annual Geotechnical Inspection, was prepared by

*This signature was scanned with the author's
approval for exclusive use in this document;
any other use is not authorized.*

Peter Healey, PEng
Principal Consultant

All data used as source material plus the text, tables, figures, and attachments of this document have been reviewed and prepared in accordance with generally accepted professional engineering and environmental practices.

Disclaimer—SRK Consulting (Canada) Inc. has prepared this document for Teck Resources Limited. Any use or decisions by which a third party makes of this document are the responsibility of such third parties. In no circumstance does SRK accept any consequential liability arising from commercial decisions or actions resulting from the use of this report by a third party.

The opinions expressed in this report have been based on the information available to SRK at the time of preparation. SRK has exercised all due care in reviewing information supplied by others for use on this project. Whilst SRK has compared key supplied data with expected values, the accuracy of the results and conclusions from the review are entirely reliant on the accuracy and completeness of the supplied data. SRK does not accept responsibility for any errors or omissions in the supplied information, except to the extent that SRK was hired to verify the data.

Figures

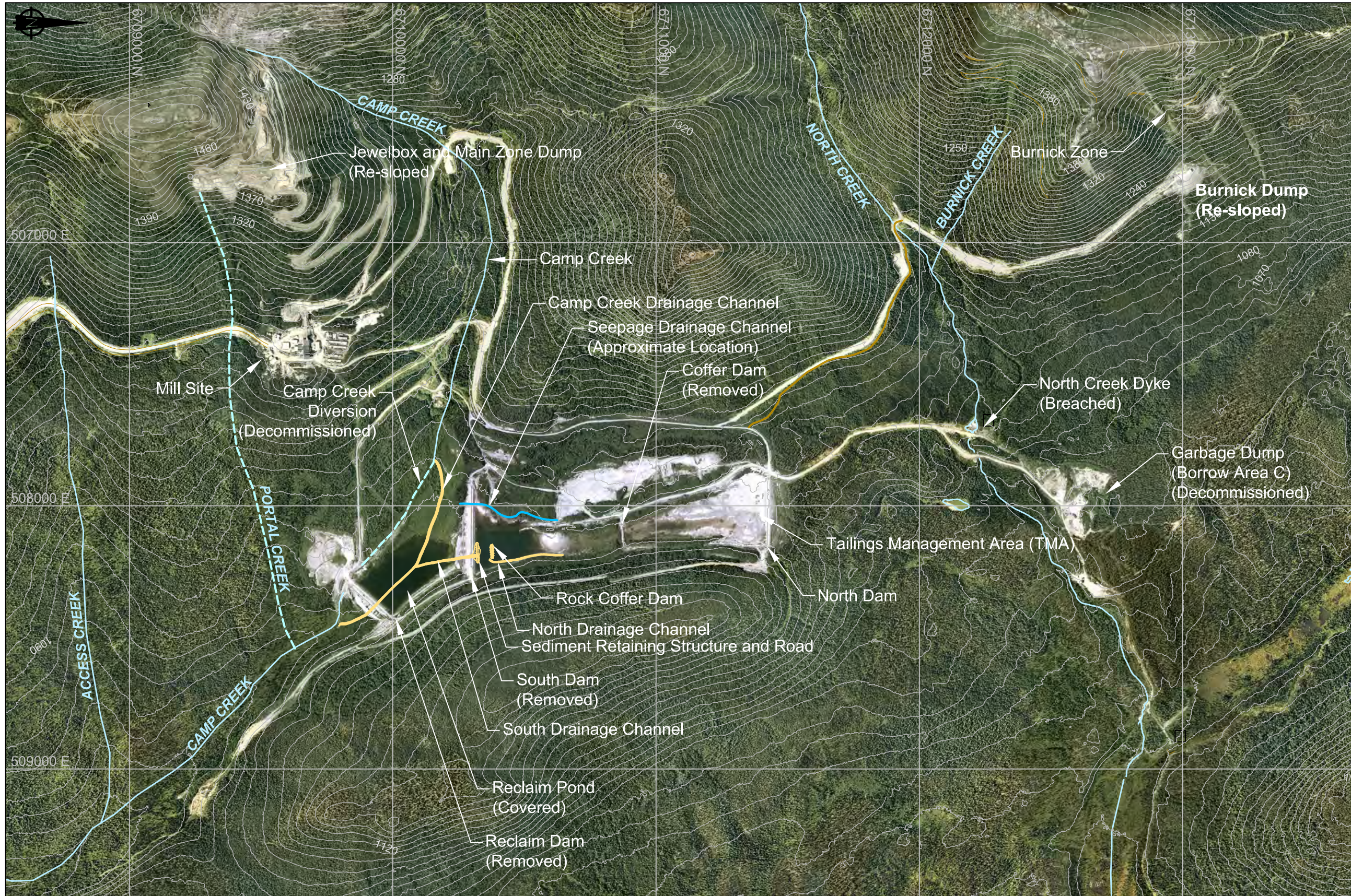

- NOTES**
1. Topographic contour data and aerial photos were obtained from McElhanney and are based on August 15, 2012 LiDAR survey. Coordinate system is UTM NAD 83CSRS zone 9V.
 2. Orthographic photo depicts pre-decommissioned surface.

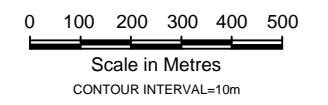

P:\01_SITES\Sa_Dena_Hes\1CT008.053 - 2015 Geotechnical Investigation\040_AutCAD\1CT008.053 - Vicinity Map.dwg

		2015 Geotechnical Inspection		
		Vicinity Map		
SRK JOB NO.: 1CT008.053 FILE NAME: 1CT008.053 - Vicinity Map.dwg	Sä Dena Hes Project	DATE: November 2015	APPROVED: PH	FIGURE: 1

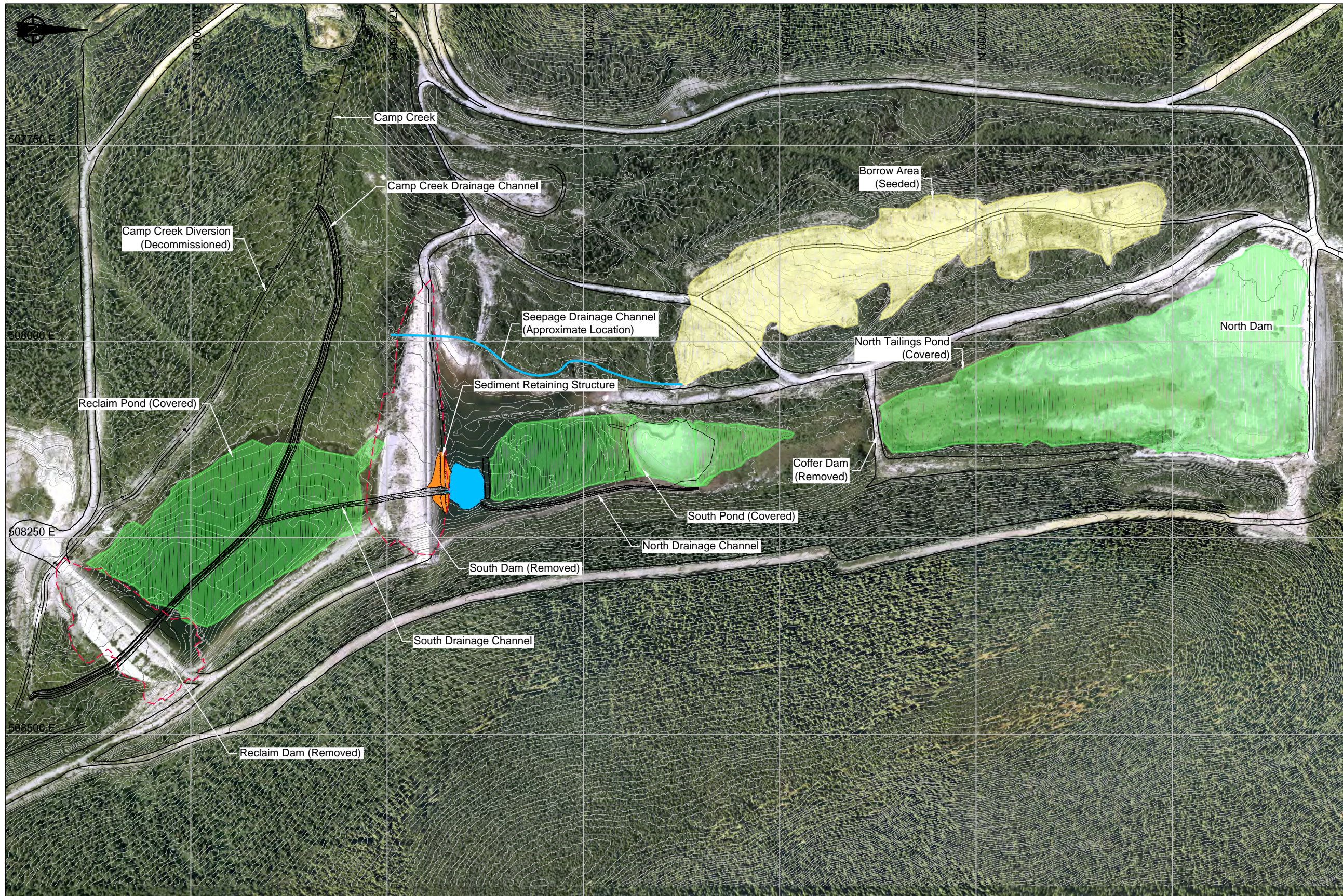

LEGEND

- Major Contour (5m interval)
- Minor Contour (1m interval)
- Edge of Road
- Design Edge of Road
- Camp Creek Drainage Channel
- - - Dam Excavation Extent
- Sedimentation Pond
- Capped Areas
- Seeded Area

NOTES

1. Preconstruction topographical contour data was obtained from McElhanney and is based on August 15, 2012 LiDAR Survey.
2. As-built survey data was collected by Yukon Engineering Services and Amec Foster Wheeler.
3. Coordinate system is UTM NAD 83 CSRS Zone 9V.
4. Tailings characterization work conducted by Golder and Associates determined the location of capping at the South Pond and Reclaim Pond areas.

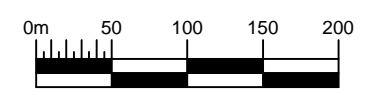

P:\01_SITES\Site Data_Hes\1CT008.053 - 2015 Geotechnical Investigation\040_AurCAD\1CT008.053 - General Arrangement.dwg

srk consulting

SRK JOB NO.: 1CT008.053
 FILE NAME: 1CT008.053 - General Arrangement.dwg

Teck

Sà Dena Hes Project

2015 Geotechnical Inspection

TMA General Arrangement Map

DATE: November 2015	APPROVED: PMH	FIGURE: 2
------------------------	------------------	--------------

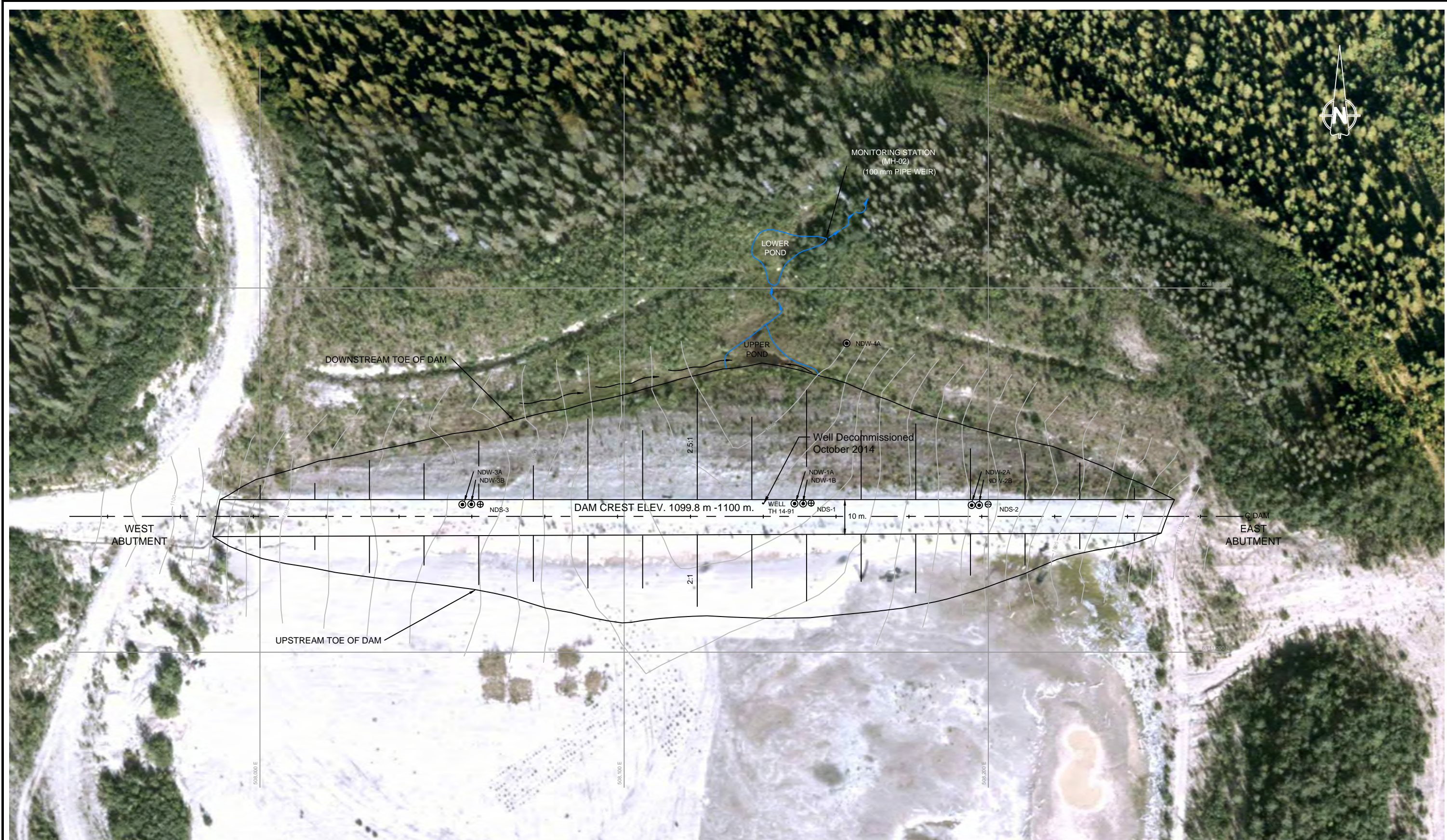

KEY

- NDW-1 PIEZOMETERS INSTALLED (NOV., 1991)
- NDS-1 SETTLEMENT GAUGE INSTALLED (NOV., 1991)
- SEEPAGE

NOTES:

1. Topographic contour data and aerial photos were obtained from McElhanney and are based on August 15, 2012 LiDAR survey and October 2013 YES Survey. Coordinate system is UTM NAD 83CSRS zone 9V.

srk consulting

SRK JOB NO.: 1CT008.053
 FILE NAME: 1CT008.053 - North Dam - plan.dwg

Teck

Sa Dena Hes Mine

2015 Geotechnical Inspection

North Dam Site Plan

DATE: November 2015	APPROVED: P.M.H.	FIGURE: 3
------------------------	---------------------	--------------

Y:\01_SITES\Sa_Dena_Hes\1CT008.053_2015_Geotechnical_Inspection\000_AutoCAD\1CT008.053 - North Dam - plan.dwg

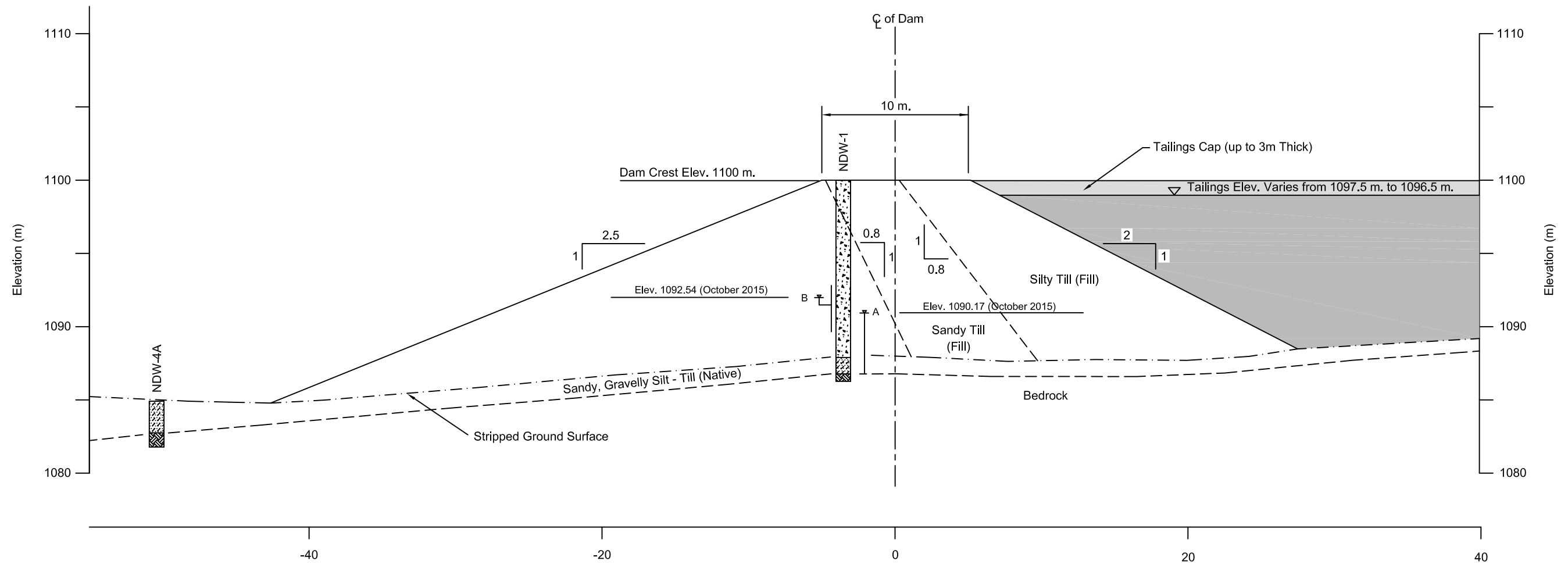

	DATE	T.O.P.	READING	ELEV.
NDW-1B	October 2015	1100.57	8.03	1092.54
NDW-1A	October 2015	1100.69	10.52	1090.17

LEGEND

	Sandy Till (Fill)		Gravelly Silty Sand (Till)		Tailings
	Silty Till (Fill)		Sand & Gravel (Native)		Tailings Cap
	Sand & Gravel(Fill)		Bedrock		
	Silty Sand (Till)		Piezometric Head for Filter Zone Indicated		

NOTES

- Topographic contour data and aerial photos were obtained from McElhanney and are based on August 15, 2012 LiDAR survey. Coordinate system is UTM NAD 83CSRS zone 9V.

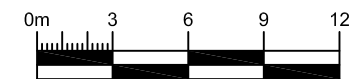





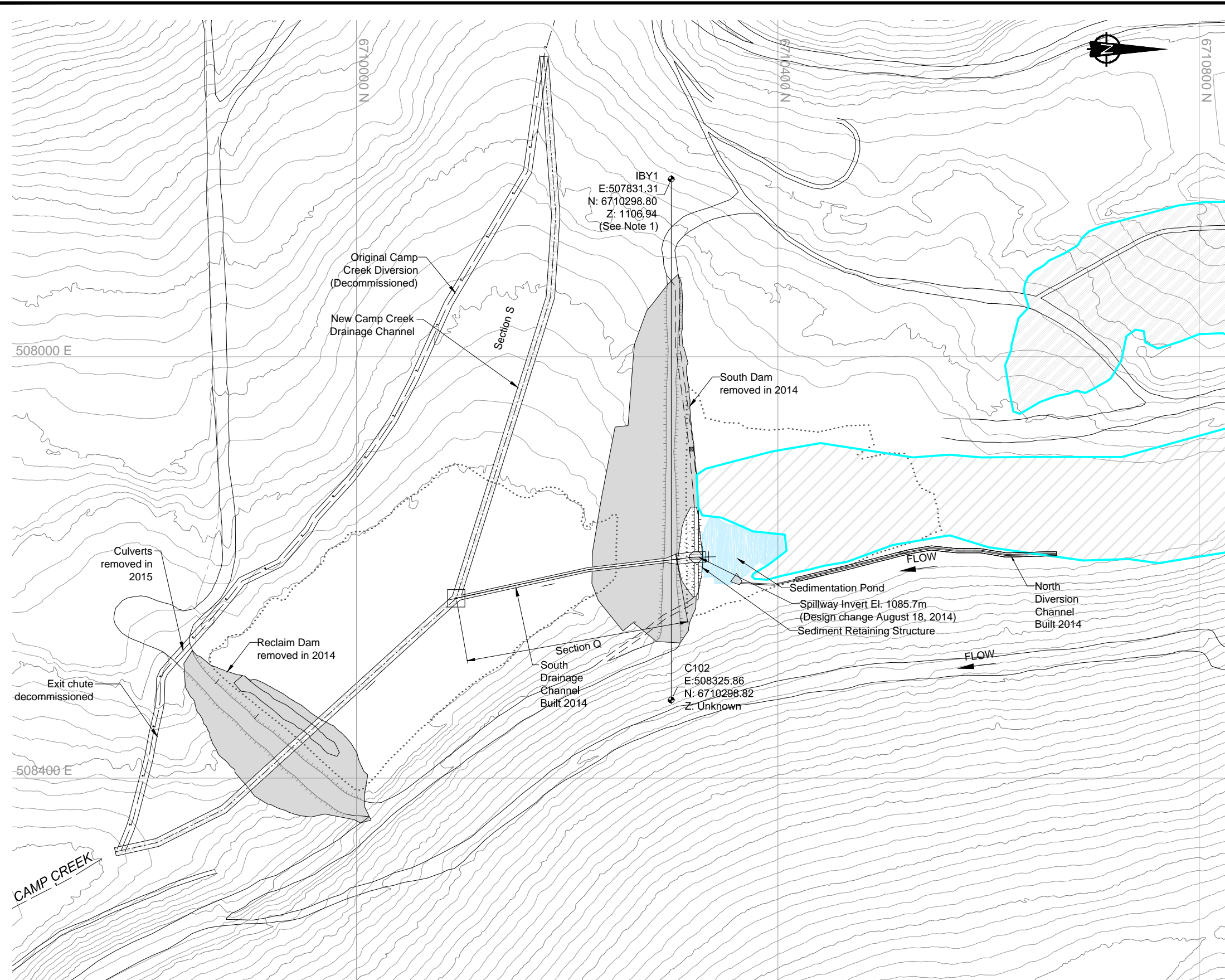

		2015 Geotechnical Inspection	
		North Dam Section 0+400	
SRK JOB NO.: 1CT008.053 FILE NAME: 1CT008.053 - North Dam XS.dwg	Sä Dena Hes Project	DATE: November 2015	APPROVED: PMH
			FIGURE: 4

P:\01_SITES\Sä_Dena_Hes\1CT008.053 - 2015 Geotechnical Investigation\040_AutoCAD\1CT008.053 - North Dam XS.dwg



LEGEND

-  Covered Tailings
-  Removed Dams
-  Sedimentation Pond
-  Minor Contours (1m interval)
-  Major Contours (5m interval)
-  Camp Creek
-  Drainage Channel

NOTES

1. This Benchmark datum is currently used to monitor settlement gauges on the dam and was used as the benchmark in construction of the dam. The elevation has been adjusted from 1103.54m to the current LiDAR Survey elevation.

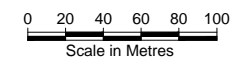

P:\01_SITES\Sa_Dena_Hes\1CT008.053_2015 Geotechnical Investigation\040_AurCAD\1CT008.053_TMF.dwg

			2015 Geotechnical Inspection	
	Sa Dena Hes		Sediment Retaining Structure Location Map	
SRK JOB NO.: 1CT008.053 FILE NAME: 1CT008.053 - TMF.dwg		DATE: November 2015	APPROVED: PMH	FIGURE: 5

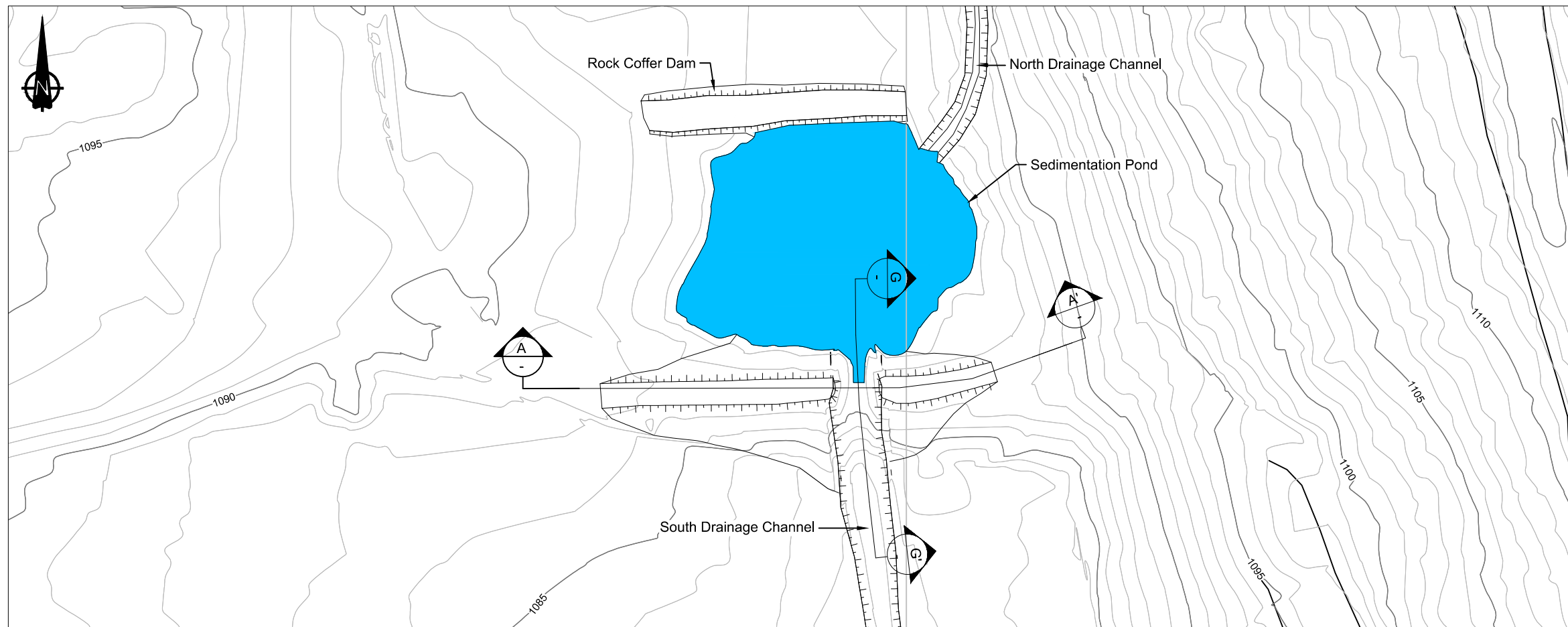

- LEGEND**
- Major Contour (5m)
 - Minor Contour (1m)
 - Dam Crest
 - Dam Toe
 - Edge of Road
 - Sediment Pond
- PROFILE AND DETAIL LEGEND**
- Original Ground
 - Non-woven Geotextile
 - ▨ Riprap

- NOTES**
1. Excavated dam fill material was used to cap tailings. The final excavated surface was graded to promote drainage and blended topography into adjacent natural topography.
 2. Rip rap from downstream toe buttress was salvaged and reused during channel construction.
 3. The decant tower was demolished down to the foundation. Steel reinforced concrete was deposited in the onsite landfill located in Borrow Area C. The remaining concrete foundation was covered with dam fill material and graded to blend into topography.
 4. Design extents of rip rap and geotextile, as no as-built survey.

Plan

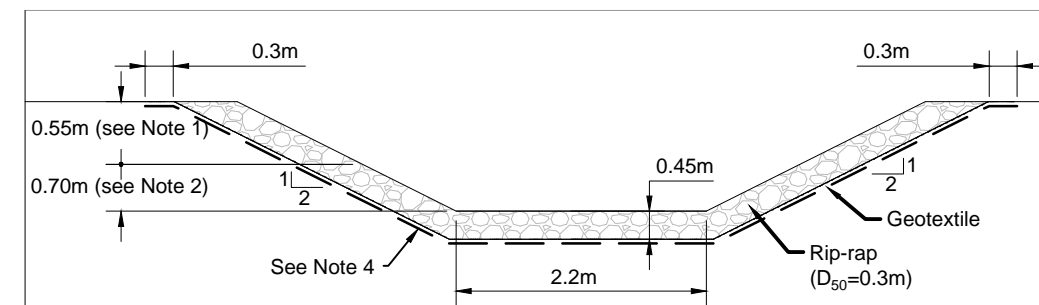
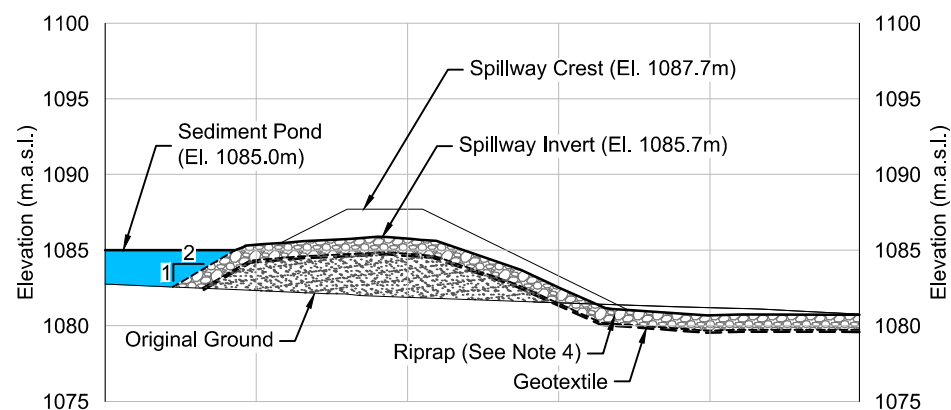
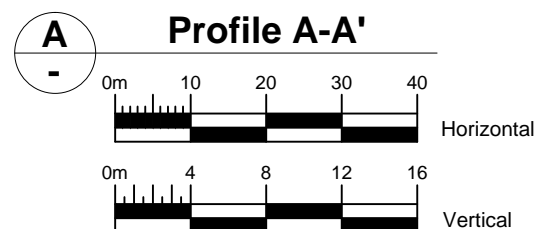
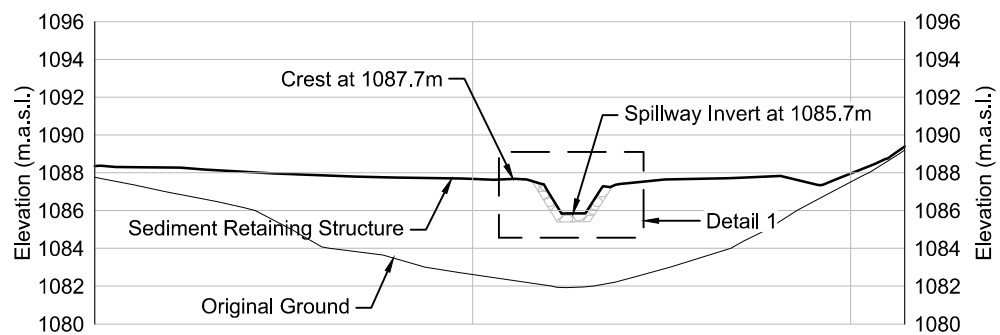

1

Detail 1 - Design Spillway Typical Section

N.T.S.

P:\01_SITES\5. Data_Hes\1CT008.053 - 2015 Geotechnical Investigation\040_AurCAD\1CT008.053 - Sediment Retaining Structure.dwg

srk consulting

SRK JOB NO.: 1CT008.053
FILE NAME: 1CT008.053 - Sediment Retaining Structure.dwg

Teck

Sà Dena Hes Project

2015 Geotechnical Investigation

Sediment Retaining Structure
Plan and Profile

DATE: November 2015	APPROVED: PMH	DRAWING: 6
------------------------	------------------	---------------

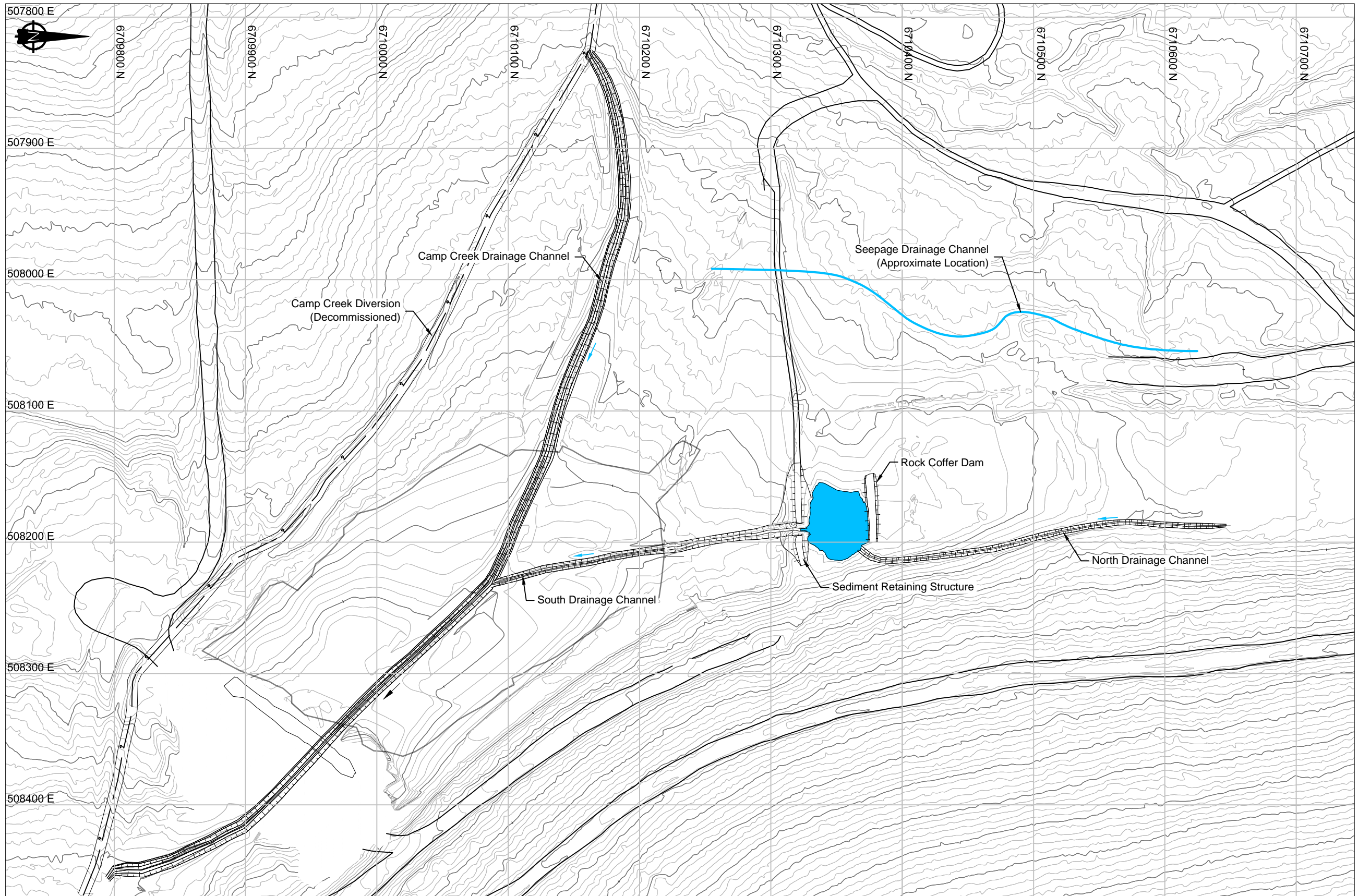

LEGEND

	Major Contour (5m)
	Minor Contour (1m)
	Dam Crest
	Dam Toe
	Edge of Road
	Direction of Flow
	Sediment Pond

NOTES

- As-built Camp Creek Drainage Channel upstream and downstream tie-in locations and North Drainage Channel alignments were modified from the design by Amec foster wheeler, with consultation from SRK and Teck, based on field conditions.

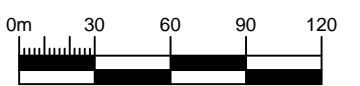

P:\01_SITES\Sa_Dena_Hes\1CT008.053 - 2015 Geotechnical Investigation\040_AutoCAD\1CT008.053 - Drainage Channel.dwg

		2015 Geotechnical Investigation		
		Drainage Channel Plan		
SRK JOB NO.: 1CT008.053 FILE NAME: 1CT008.053 - Drainage Channel.dwg	Sä Dena Hes Project	DATE: November 2015	APPROVED: PMH	DRAWING: 7

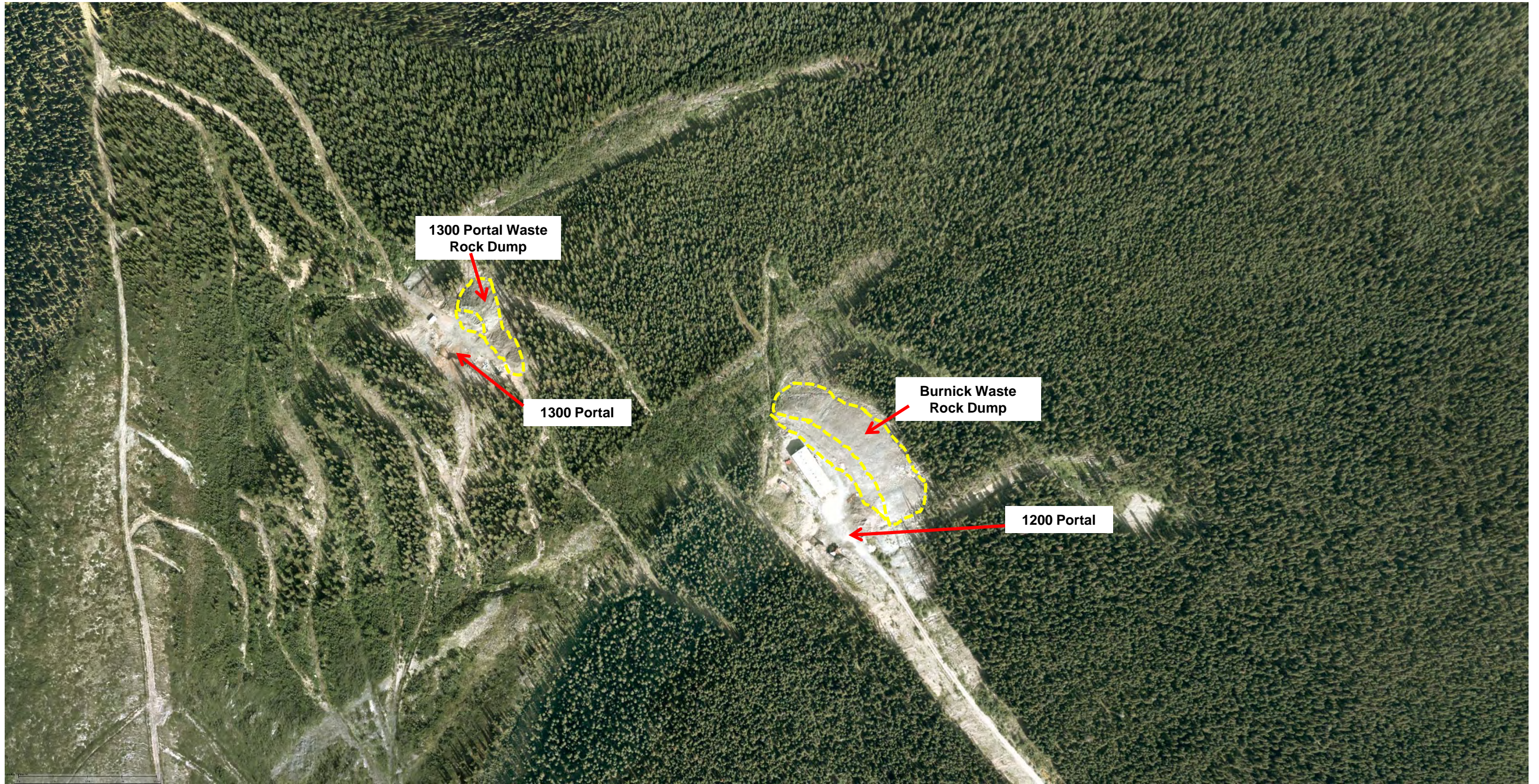

		2015 Geotechnical Inspection		
		Burnick Zone Plan View		
Job No: 1CT008.053 Filename: Burnick Zone.pptx	Sä Dena Hes	Date: November 2015	Approved: PMH	Figure: 8

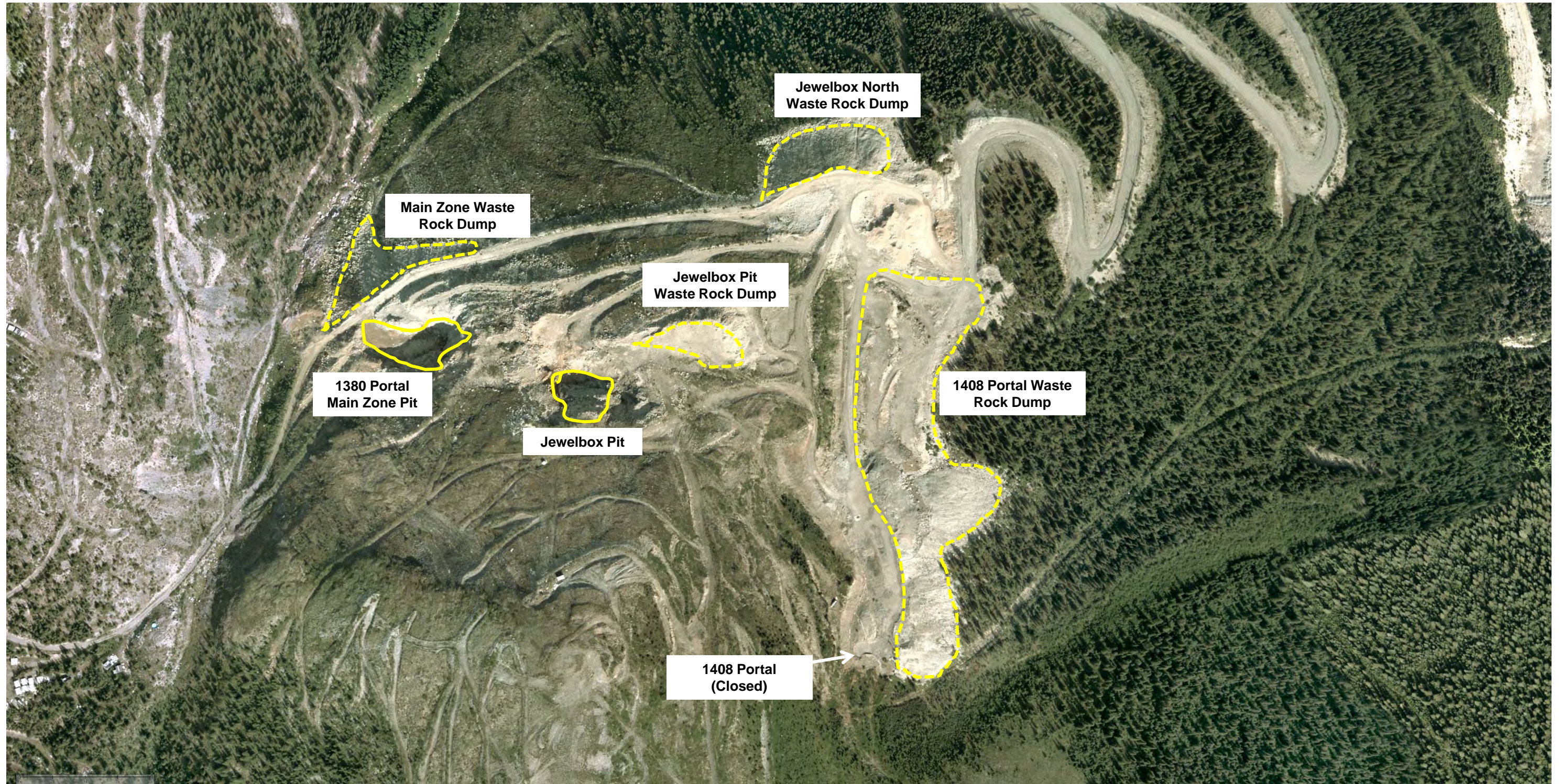

Appendix A: Photo Log



Photo 1: View west over the Mine Site



Photo 2: View south over the Tailings Management Area



Photo 3: View east over the Sediment Retaining Structure



Photo 4: View North of the new Camp Creek Drainage Channel



Photo 5: View looking west over the North Dam



Photo 6: View looking west along the North Dam showing the downstream slope



Photo 7: Protective steel casing for the Piezometers in the North Dam



Photo 8: North Dam Settlement gauges



Photo 9: Deformation gauges installed during construction of the North Dam. Removed during decommissioning.



Photo 10: Test through the till cover on the tailings. Depth of cover about 2.14m



Photo 11: Temporary drainage ditch to manage water during cover placement



Photo 12: Wetland area on the east side of the TMA just above the SRS



Photo 13: View of the rockfill cofferdam above the SRS



Photo 14: View looking west of the spillway through the SRS.



Photo 15: Sedimentation Pond at the SRS. North diversion channel is seen to the right of the photo.



Photo 16: Silt fences for TSS management



Photo 17: Channel through the North Creek Dyke following removal of the CMP culvert



Photo 18: Burnick Dump



Photo 19: Main Zone dump

Appendix B: Water Levels

Depth to Water - North Dam Crest Piezometers 2014-15

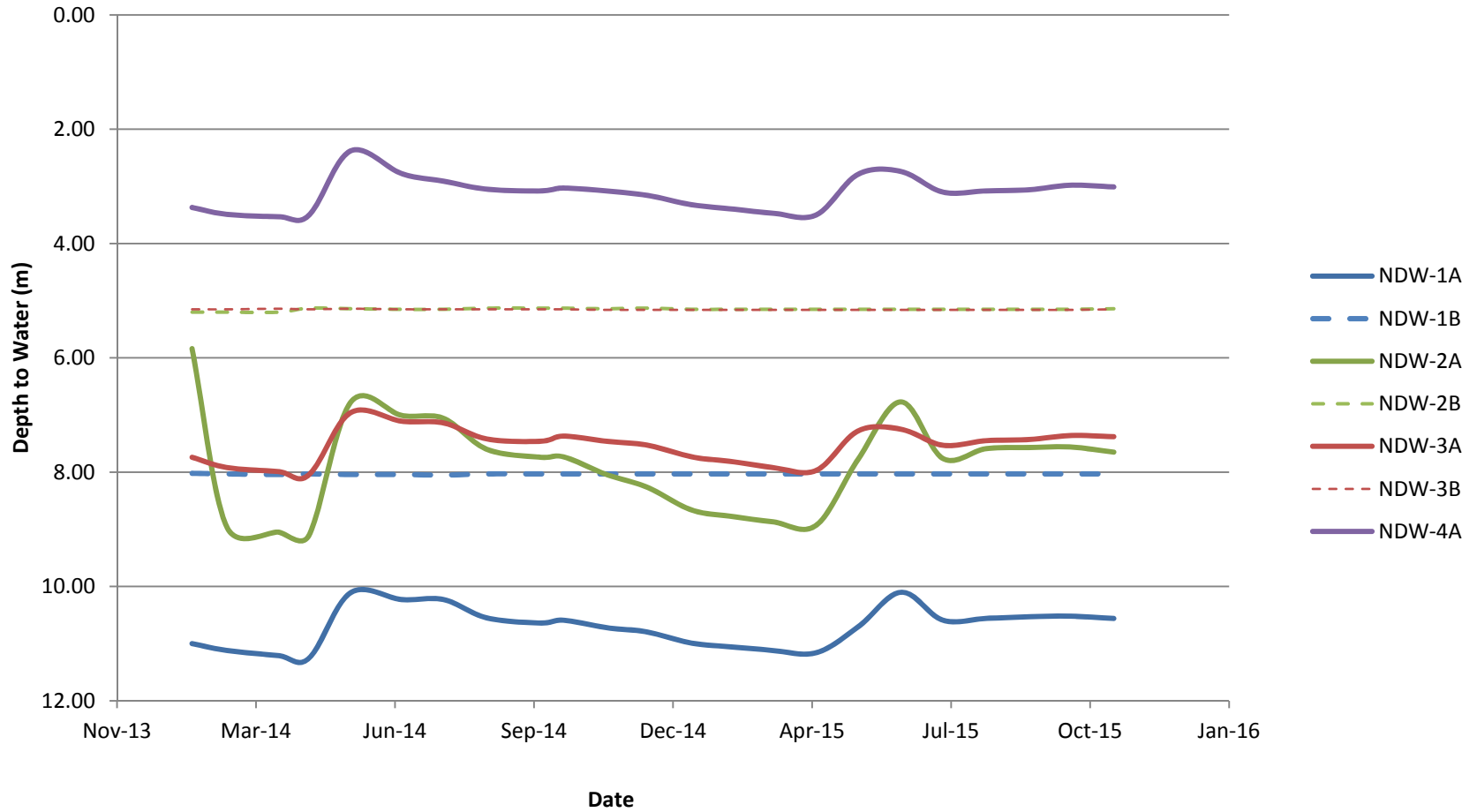

		North Dam		
		2014-2015 Piezometric Levels in North Dam		
Job No: 1CT008.053 Filename: FigB1_2014_2015PiezoLevels_1CT008.046_rev2.pptx	Se Dena Hes	Date: October 2015	Approved: PMH	Figure: B1