

Sä Dena Hes

North Embankment Upgrade Project Plan

QUARTZ MINE LICENCE QML-0004

Date: March 5, 2025

Summary

The Sä Dena Hes (SDH) mine was a lead/zinc mine located 70 km north of Watson Lake by road in southeastern Yukon within the Traditional Territory of the Liard First Nation. The mine has been in temporary and then final closure since 1992. Teck Resources Limited (Teck), on behalf of the Sä Dena Hes Operating Corporation, completed decommissioning and reclamation activities in 2014 in accordance with the approved Sä Dena Hes Mine Detailed Decommissioning & Reclamation Plan (DDRP) (Teck, 2015).

Tailings are managed in a Tailings Management Area. The original Tailings Management Area included three earth structures referred to as the North Dam, the South Dam and the Reclaim Dam. During decommissioning works in 2014, the dams were removed, and the only remaining tailings retaining embankment is the North Embankment. In June 2022, an erosion gully developed on the North Embankment. The erosion was caused by ponded snow melt water overtopping the embankment. The gully was repaired in 2022; however, additional upgrades to the embankment were recommended by the Engineer of Record to reduce future risk of overtopping. The upgrade activities are maintenance works in accordance with the Quartz Mining Licence (QML-0004) issued on December 31, 2015.

The North Embankment Upgrade Detailed Design consists of the following:

- A raise of the North Embankment by 2.3 m
- Construction of an upstream beach south of the embankment that drains away from the embankment at a 3% grade
- Additional cover placement in areas where ponding occurs and construction of additional drainage swales on the cover
- Construction of a 0.5 m armouring layer on the downstream slope of the North Embankment
- Construction of seepage collection channels downstream of the North Embankment and installation of two steel plate v-notch weirs

This Project Plan describes the environmental protection and operational plans for the North Embankment Upgrade project and has been developed based on the guidance document Plan Requirement Guidance for Quartz Mining Projects (Yukon Water Board and Yukon Energy, 2013). The Project Plan describes how the elements of the upgrade will be implemented and provides plans for reclamation, environmental monitoring, protection of heritage resources, spill response, waste management, sediment and erosion control, and health and safety.

Concordance Table

The following table includes the updates based on comments from the Government of Yukon dated December 30, 2024, and general updates since the Project Plan was submitted in March 2024.

Section	Update Description
Section 1.0, Section 4.1 and Section 12	Updated naming conventions for the Worker's Safety and Compensation Board
Section 1.0	Addressed comment from EMR: -Provide description of the North Embankment: it's design purpose, performance history, and all existing design features.
Section 1.0	Updated design details
Section 1.4	Addressed comment from EMR: -Provide description of role and responsibilities related to geotechnical performance, ensuring stability of engineered structures and infrastructure.
Section 4.2	Addressed EMR update request: -Provide results of any risk assessment undertaken prior to the upgrade of existing site Access Road. Identification of any large-scale terrain hazards, assessment of rock and soil cuts along the road, and mitigation measures put into place prior to road surface upgrade.
Section 3.1	Addressed EMR update requests: - Provide summary of material testing completed on quarry materials, any durability testing, and design specifications. - Provide indication of suitable material gradation and both fine and coarse limits stockpile for the North Embankment and Camp Creek crossing.
Section 3.2	Addressed EMR update request: - Provide indication of suitable material gradation and both fine and coarse limits stockpile for the North Embankment construction material. - Provide clarification that borrow area materials used for construction will be free of organic matter, frozen soil, snow, ice, and overburden soil material.
Section 6.5	Addressed EMR update requests: -Provide updates to the wildlife protection plan section that adhere to existing Yukon guidance materials. -Provide process for reporting wildlife issues should they be encountered and Yukon specific contact information.
Section 6.6	Added a bullet to avoid steep slopes to prevent bank swallow nesting.
Section 8.3	Addressed EMR update request: Provide clarification and detail on what is meant by the phase/term "geotechnically stable state".

All copies of this document are uncontrolled when printed.

Section	Update Description
Section 9.4	Clarified that no spill equipment is stationed on site and that contractors bringing products on-site must have appropriate spill response materials.
Section 11.0 and 11.1	<p>Addressed EMR update requests:</p> <ul style="list-style-type: none"> - Provide more detail regarding adaptive management or contingency measures as they relate to potential observed erosion and sedimentation. - Provide temporary erosion control measures during construction should there be idle periods during the construction period when work is not yet completed but exposed to the elements. In addition, describe any temporary erosion control measures necessary to address areas vulnerable to erosion when decided upon wind and precipitation threshold reached. - Provide clarification and more detail regarding the construction, implementation, and monitoring of water conveyance features included within the designs for the access road. - Updated water quality review during activities around camp creek.
Section 12.4	<p>Addressed EMR update requests:</p> <ul style="list-style-type: none"> - Provide any review of facility stability pre-construction with reference to annual reports (SRK). Describe stability of tailings and cover when subjected to loading and vibration from construction activities and review potential settlement expectations. Include a brief discussion of failure modes and visual indicators or refer to Emergency Plan. - Provide more detail regarding the thresholds for trigger action responses and the specific conditions for each trigger level. - Provide more detail and reference to runout analysis completed, and include detail regarding the extent of area that would be impacted.

All copies of this document are uncontrolled when printed.

TABLE OF CONTENTS

1.0	Introduction and Project Overview	1
1.1	Mine History	5
1.2	Location and Access	5
1.3	Regulatory Authorization and Approvals	6
1.4	Roles and Responsibilities	9
1.5	Document Outline	13
2.0	Environmental Setting	14
2.1	Climate	14
2.2	Geology and Soils	15
2.3	Watershed and Hydrology	15
2.4	Vegetation	16
2.5	Wildlife	16
2.6	Aquatic Resources	17
3.0	Borrow Source Development	19
3.1	KM17 Quarry Development	19
3.2	Reclaim Borrow Area Development	20
4.0	Access Development Plan	22
4.1	Upgrading the Site Access Road	22
4.2	Reestablishing a Trail Between the Reclaim Borrow Area and the Site Access Road	22
4.3	Drill Pathway	24
5.0	North Embankment Upgrade Plan	25
5.1	Embankment Raise	25
5.2	Upstream Beach	26
5.3	Downstream Slope Erosion Protection	26
5.4	Seepage Weirs	26
5.5	West Abutment Diversion Channel	27
5.6	Tailings Cover Upgrade	27
5.7	Surveillance During Construction	27
5.8	Surveillance Post-Construction	28
6.0	Environmental Protection Plans, Monitoring, Surveillance and Reporting Plan	29
6.1	Vegetation Management	29
6.2	Water Management	29
6.3	Protection of Water Quality	30
6.4	Protection of Fish	30

All copies of this document are uncontrolled when printed.

6.5	Wildlife Protection Plan	31
6.6	Bird and Nest Protection Plan	32
6.7	Record Keeping	33
7.0	Heritage Resources Protection Plan	35
8.0	Reclamation Plan	36
8.1	Reclaim Borrow Area Access Trail	36
8.2	Reclaim Borrow Area	37
8.3	KM17 Quarry	37
8.4	North Embankment	37
9.0	Spill Contingency Plan	38
9.1	Chemical Products	38
9.2	Reportable Spill Thresholds	38
9.3	Spill Prevention	38
9.4	Spill Action Plan	39
9.5	Internal and External Reporting	39
10.0	Waste Management Plan	41
10.1	Waste Types	41
10.2	Hazardous Waste Management	42
11.0	Sediment and Erosion Control Plan	43
11.1	Erosion and Sedimentation Sources and Control Measures	43
11.2	Monitoring Strategies	44
12.0	Health and Safety	45
12.1	Health and Safety Management Framework for Projects	45
12.2	Traffic Management	47
12.3	Emergency Response Planning	47
12.4	Site and Dam Stability	48
13.0	Schedule	50
14.0	Closure	51
15.0	References	52
Appendix A	Design Basis Memorandum	53
Appendix B	Design Drawings	54
Appendix C	Environmental Inspection Checklist	55
Appendix D	Cultural Heritage Resource Chance Find Procedure	56
Appendix E	Spill Contingency Plan	57
Appendix F	Mine Emergency Response Plan	58

All copies of this document are uncontrolled when printed.

LIST OF TABLES

Table 1.1 Summary of Permits, Authorizations, and Notifications that may be Required for the North Embankment Upgrade Project.....	6
Table 1.2 Legislation that Must be Considered Throughout the North Embankment Upgrade Project	7
Table 1.3 Roles and Responsibilities During the North Embankment Upgrade Project.....	10
Table 2.1 Estimated Mean Monthly Climatic Data for the Tailings Management Area	14
Table 3.1 North Embankment armoring rock gradation requirements, as per SRK design....	20
Table 3.2 Till Gradation Requirement	21
Table 9.1 Reportable Spill Volumes for Fuels According to the Yukon Spills Regulation	38
Table 13.1 Preliminary Project Schedule	50

LIST OF FIGURES

Figure 1.1 Location of the Sä Dena Hes Mine Site	3
Figure 1.2 Location of the Project Plan Activities	4
Figure 2.1 Location of Sä Dena Hes Relative to Wildlife Key Areas in the Region.....	18
Figure 5.1 Embankment Geometry Schematic (from the Design Basis Memorandum, SRK 2023)	26

1.0 Introduction and Project Overview

The Sä Dena Hes (SDH) mine was a lead/zinc mine located 70 km north of Watson Lake by road in southeastern Yukon within the Traditional Territory of the Liard First Nation (Figure 1.1). The mine has been in temporary and then final closure since 1992. Teck Resources Limited (Teck), on behalf of the Sä Dena Hes Operating Corporation, completed decommissioning and reclamation activities in 2014 in accordance with the approved Sä Dena Hes Mine Detailed Decommissioning & Reclamation Plan (DDRP) documented in the August 2015 Update (Teck, 2015).

Tailings are managed in a Tailings Management Area (TMA). The original TMA included three earth structures referred to as the North Dam, the South Dam and the Reclaim Dam. During decommissioning works in 2014, the dams were removed, and the only remaining tailings retaining embankment is the North Embankment (Figure 1.2).

The purpose of the North Embankment is to retain tailings at the north end of the TMA. The North Embankment is a 15 m high earthfill structure with a crest width of 10 m. The structure has a length of 280 m and has a 2.5H:1V downstream slope. The structure contains an upstream silty till zone, a central sandy till filter zone and a sand and gravel downstream zone. This is a “dry” tailings impoundment. There is no permanent storage of water and the impoundment is normally dry except during freshet when a pond may seasonally form. The embankment has performed well since construction. The tailings behind the North Embankment were capped with a till cover in 2014 with the cover tied into the upstream crest of the embankment. The cover was sloped to drain water away from the crest and to the south. A shallow swale (main drainage swale) was constructed down the middle of the cover to direct the surface runoff to the south. A pond develops annually during the snowmelt period adjacent to the dam that is believed to be primarily caused by restricted drainage to the south, likely due to snow and/or ice blockages.

In June 2022, an erosion gully developed on the North Embankment. The erosion was caused by ponded snow melt water overtopping the embankment. This was not a result of poor dam performance, but rather due to blockage of drainage across the reclamation cover. The gully was repaired in 2022; however, additional upgrades to the embankment were recommended by the Engineer of Record to reduce future risk of overtopping (Appendix A – North Embankment Upgrade Detailed Design). The upgrade activities are maintenance works in accordance with the Quartz Mining Licence (QML-0004) issued on December 31, 2015. The North Embankment Upgrade Detailed Design (Appendix A) consists of the following:

- A raise of the North Embankment by 2.3 m
- Construction of an upstream beach south of the embankment that drains away from the embankment at a 3% grade
- Additional cover placement in areas where ponding occurs and construction of additional drainage swales on the cover
- Construction of a 0.5 m armouring layer on the downstream slope of the North Embankment

All copies of this document are uncontrolled when printed.

- Construction of seepage collection channels downstream of the North Embankment and installation of two steel plate v-notch weirs

This Project Plan describes the environmental protection and operational plans for the North Embankment Upgrade project and has been developed based on the guidance document Plan Requirement Guidance for Quartz Mining Projects (Yukon Water Board and Yukon Energy, 2013). The Project Plan includes three distinct project activities as follows:

- Borrow material development
 - Sourcing embankment armouring from a quarry that was developed during reclamation activities (KM17 quarry)
 - Sourcing till material from the Reclaim Dam borrow area
- Access development
 - upgrading the site access road
 - reestablishing a trail between the reclaim borrow and the site access road, which includes a crossing at Camp Creek
 - developing a pathway for a track-mounted drill to install piezometers
- Construction activities specific to the North Embankment Upgrade

Figure 1.2 shows the locations of the planned project activities.

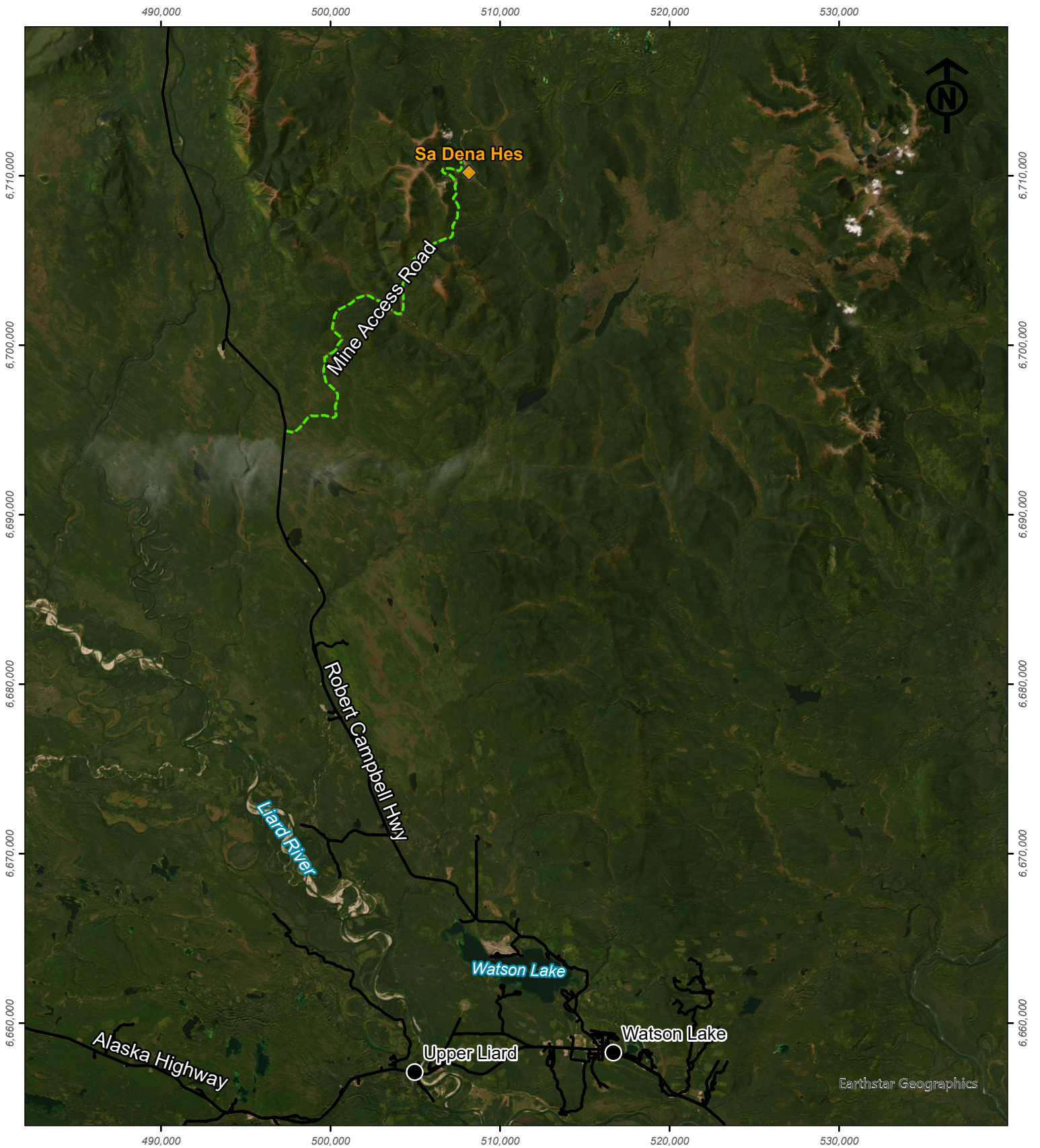

Teck

The maps and map data are provided "as is" without any guarantee, representation, condition or warranty of any kind, either express, implied or statutory. Teck Resources Limited assumes no liability with respect to any reliance the user places in the maps and map data, and the user assumes the entire risk as to the truth, accuracy, currency, or completeness of the information contained in the maps and map data.



Location of the Sä Dena Hes Mine Site

-  TLP Sa Dena Hes
-  Communities
-  Gravel Road (2WD)
-  Major Roads

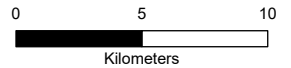

1:300,000

FIGURE: FIG 1-1	PROPERTY: SA DENA HES
DATE: 12/10/2023	COORDINATE SYSTEM: NAD 1983 UTM Zone 9N

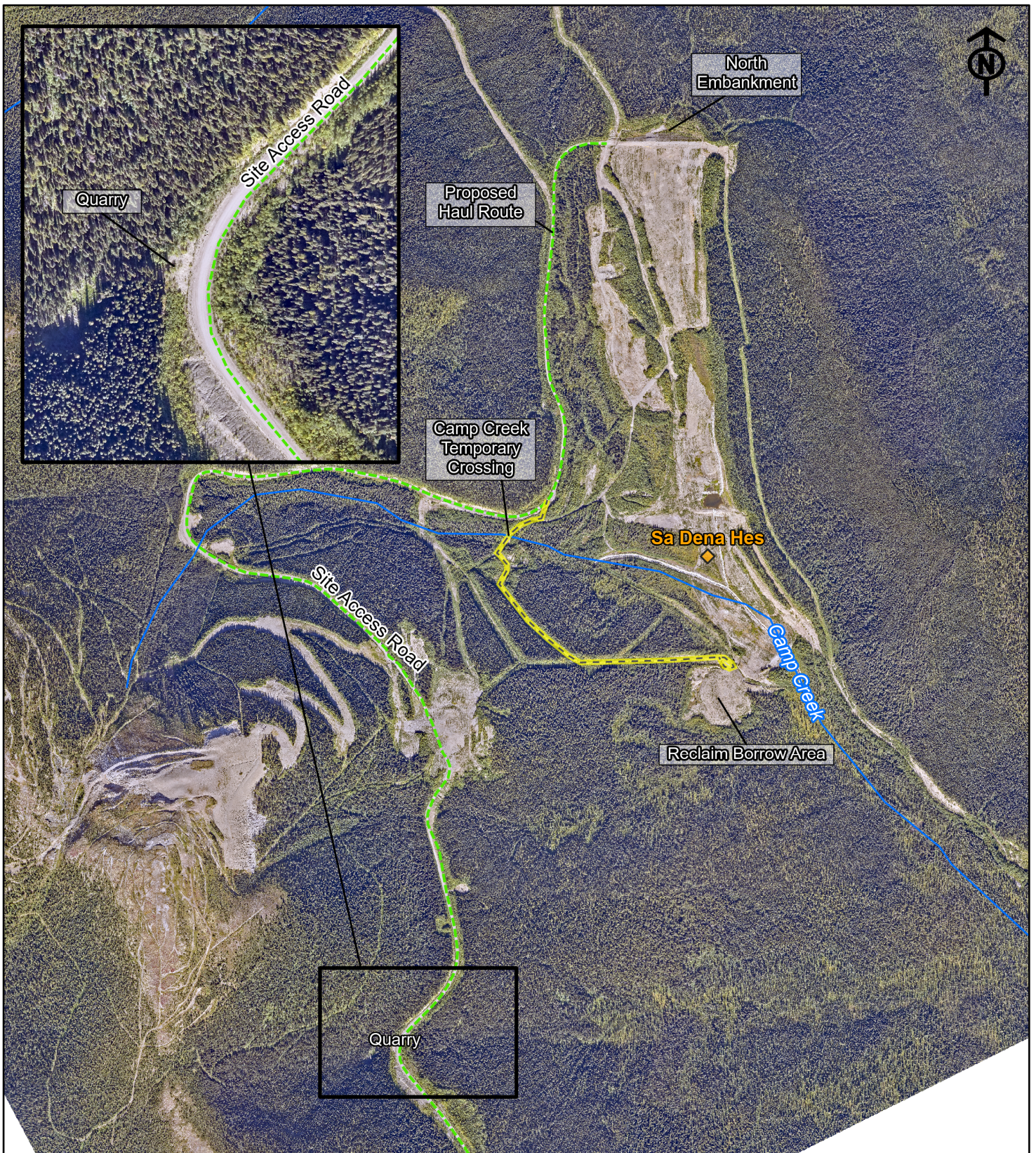

Teck

The maps and map data are provided "as is" without any guarantee, representation, condition or warranty of any kind, either express, implied, or statutory. Teck Resources Limited assumes no liability with respect to any reliance the user places in the maps and map data, and the user assumes the entire risk as to the truth, accuracy, currency, or completeness of the information contained in the maps and map data.



**Sa Dena Hes
Location of Project Plan Activities**

- ◆ Sa Dena Hes Site
- Watercourse
- - - Access Road
- - - Access Trail - To be reestablished

0 500

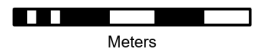

Meters
1:16,000

FIGURE: FIG 1-2	PROPERTY: SA DENA HES
DATE: 2/27/2024	COORDINATE SYSTEM: NAD 1983 UTM Zone 9N

1.1 Mine History

The original surface outcroppings were discovered by prospectors working for the Francis River Syndicate in 1962. Between 1962 and 1989, several exploration campaigns were conducted by multiple mineral holders. In 1990, a mine development plan was approved as a project and the property was put into production in August 1991.

The first zinc and lead concentrate shipment to the port of Skagway, Alaska occurred in September, 1991. Mine production rates and mill processing exceeded design capacity of 1,500 tonnes per day during the production period. The maximum mill throughput was over 1,800 tonnes per day. During the 16 months of production, approximately 700,000 tonnes of ore were mined and processed. Approximately 120,000 tonnes of zinc concentrates were produced with a grade of 59% Zinc and 54,000 tonnes of lead concentrates at a grade of 77% Lead. The concentrates were trucked in covered containers to Skagway for shipment to European and Asian smelters. A sharp downturn in metal prices forced the mine to shut down in December 1992, at which time the property transitioned to a care and maintenance phase. Curragh Resources sought and received Court protection under the *Corporations and Creditors Arrangement Act* in 1993. On September 20, 1993, Coopers & Lybrand Ltd. was appointed by the court as Receiver and Manager of the Sä Dena Hes property.

In March 1994, the current owners purchased the property through the Receiver according to a Court Order. The property has been kept in care and maintenance except for a brief period in the winter of 1998 when preparations began for reopening. A downturn in metal prices forced a re-evaluation, and subsequent suspension of work.

Decision for permanent closure was made in 2013 and reclamation activities were completed in 2014. Since then, the primary activities on site have been inspection and monitoring according to the Quartz and Water licences, in addition to as-required maintenance. The Sä Dena Hes Mine is managed by Teck's Legacy Properties group, based in Kimberley, BC, which is responsible for managing a portfolio of Teck-owned closed properties.

1.2 Location and Access

The Sä Dena Hes property is located close to Yukon's southern boundary with British Columbia, approximately 70 kilometres by road from the Town of Watson Lake. Access to the site is via the Robert Campbell Highway (Highway #4) north of Watson Lake. At approximately KM47, there is a turn-off to a 25-km access road that extends to the property.

Sä Dena Hes is within Treaty 11 territory, and the traditional territories of the Liard First Nation, a member of the Kaska Nation. There are two registered traplines associated with the Sä Dena Hes property and its site access road, both of which are included on the Yukon 105A NTS Map Sheet. The site access road runs through registered trapline number 358, while the property is located within trapline number 356.

Service and haul roads that provided access to the mine workings, tailings management area and site infrastructure were decommissioned during the 2014 reclamation activities, with the exception of one access road to the north end of the Tailings Management Area. All culverts and berms were removed, and roadbeds were recontoured to restore original drainage patterns and to provide stability and long-term erosion control. Road surfaces underwent decompaction and a seed mix of native graminoids and legumes was applied.

1.3 Regulatory Authorization and Approvals

In December 2015, Teck amended its Quartz Mining Licence (QML) QML-0004 for the post-reclamation phase of the mine. The amended QML expires on December 31, 2040. The scope of the authorization is “Reclamation, remediation, closure and post-closure care and maintenance to the production and development activities that occurred at the Sä Dena Hes Mine Site”. The activities associated with the North Embankment Upgrade project are in accordance with the scope authorization.

In addition, a Type B Water Use Licence, QZ16-051, was issued in 2017. The purpose stated in the licence was “To store/alter flow of water associated with maintenance and decommissioning activities and to deposit a waste to water). The Water Licence also expires on December 31, 2040.

In addition to the QML and Water Licence, other licences and approvals that may be required as part of the overall Project are summarized in Table 1.1. Teck is responsible for obtaining the necessary approvals or will require contractors to hold permits to conduct work according to regulations (e.g., transportation of dangerous goods).

Table 1.1 Summary of Permits, Authorizations, and Notifications that may be Required for the North Embankment Upgrade Project

Authorization and Legislation	Purpose	Responsible Agency
<i>Fisheries Act</i> Notification	Camp Creek crossing temporary culvert installation and removal and water intake for dust suppression and compaction	Fisheries and Oceans Canada (DFO)
Certificate and/or Permit for Transport of Dangerous Goods, <i>Transportation of Dangerous Goods Act</i>	Transport of dangerous goods/waste	Yukon Government Highways and Public Works, Transportation Services Branch
<i>Yukon Waters Act</i> , Waters Regulation	Required for water crossings greater than 5 m and for water use of greater than 300 m ³ /day. Neither of these triggers will be met for this project. However, notification of water withdrawal is required 10 days before use.	Yukon Water Board

All copies of this document are uncontrolled when printed.

In addition to legislation that require permits, authorizations or notifications, there is other legislation that must be considered and recognized throughout the project. The legislation requirements are listed in Table 1.2.

Table 1.2 Legislation that Must be Considered Throughout the North Embankment Upgrade Project

Legislation Title	Applicable Legislation	Project Pertinence
Yukon Workplace Health and Safety Regulations	Promote workplace health and safety, and to protect workers and other workplace parties from work-related risks to their health, safety and well-being.	Workers on-site have the right to a safe workplace. Section 12.0 of this document discusses the Health and Safety plan for the project.
<i>Historic Resources Act</i>	Protection and preservation of historic resources, which include artifacts or sites that are of value for its archaeological, paleontological, pre-historic, historic, scientific or aesthetic features	The project sites are of low or negligible archaeological potential; however, if artifacts are found they must be protected according to the <i>Act</i> . Section 7.0 of this document discusses the procedures for discovery of historic resources.
<i>Wildlife Act</i> Wildlife Regulation	<p>17(1) A personal shall not destroy, take or possess any egg or nest of a bird that belongs to a species that is wild by nature.</p> <p>89(1) Every person who kills a big game animal, lynx, fox, wolverine, raptor or specially protected wildlife accidentally or otherwise without having permission to do so under this Act shall as soon as practicable after killing it report to a conservation officer.</p> <p>91(1) No person shall damage or interfere with a beaver dam, or the den, lair or nest of any wildlife</p> <p>92(1) A person shall not harass any wildlife</p> <p>93(2) No personal shall encourage any wildlife to become a public nuisance.</p>	Interaction with wildlife may occur because of the project activities. Section 6.0 of this document discusses the wildlife management plan and Section 10.0 describes how wastes will be handled to avoid wildlife habituation.

All copies of this document are uncontrolled when printed.

Legislation Title	Applicable Legislation	Project Pertinence
<i>Waters Act</i>	<p>6(2) no person shall use, or permit the use of, waters in a water management area except (a) in accordance with the conditions of a licence; or (b) as authorized by regulations made under paragraph 31(1)m</p> <p>7(2) except in accordance with the conditions of a licence or as authorized by regulations made under paragraph 31(1)(n), no person shall deposit or permit the deposit of waste (a) in any waters in a water management area; or (b) in any other place under conditions in which the waste, or any other waste that results from the deposit of that waste, may enter any waters in a water management area.</p>	<p>Activities that involve working around or near water will be conducted in accordance with the Type B Water Use Licence issued in 2017 and according to the Waters Regulations. Section 6.0 of this document describes the water management plan, mitigation measures and monitoring that will be conducted throughout the project to protect water.</p>
<i>Fisheries Act (R.S.C., 1985, c.F-14)</i>	<p>Section 34.4 prohibits activities that cause the death of fish by means other than fishing and Section 35(1) prohibits activities that result in the harmful alteration, disruption, or destruction of fish habitat unless authorization for such activities are granted by the minister.</p> <p>Section 36(3) provides clear prohibition regarding the deposition of any deleterious substance into areas of fish habitat: "(3) Subject to subsection (4), no person shall deposit or permit the deposit of a deleterious substance of any type in water frequented by fish..." unless authorization for such deposition has been granted by the minister [36(4)].</p> <p>Section 38(4.1) – Duty to notify a name authority without delay of an occurrence, or imminent danger of such occurrence, that results in a harmful alteration, disruption, or destruction of fish habitat.</p> <p>Section 38(5) – Duty to notify a named authority without delay of</p>	<p>The project does not involve work in fish-bearing waterbodies and therefore a request for project review or application for an authorization for a HADD have not been sought. The general prohibitions against causing the death of fish or a HADD still apply, as do the Section 36(3) prohibitions, and the reporting requirements of Sections 38(4.1) and 38(5).</p>

All copies of this document are uncontrolled when printed.

Legislation Title	Applicable Legislation	Project Pertinence
	an occurrence, or imminent danger of such occurrence, of a deposit of a deleterious substance in waters frequented by fish.	
<i>Migratory Birds Convention Act, 1994 Migratory Birds Regulations, 2022</i>	5(1) A person must not engage in any of the following activities unless they have a permit that authorizes them to do so or they are authorized by these Regulations to do so: (a) capture, kill, take, injure or harass a migratory bird or attempt to do so; (b) destroy, take or disturb an egg; (c) damage, destroy, remove or disturb a nest, nest shelter, eider duck shelter or duck box.	Vegetation clearing activities will be planned to occur when migratory birds are no longer in the area. However, work within vegetated areas will likely occur during nesting periods. Section 6.0 of this document discusses the management activities that will be in place to prevent impacts on migratory birds.
<i>Species at Risk Act (SARA) (S.C. 2002, c. 29)-</i>	Section 32 (1): “No person shall kill, harm, harass, capture or take an individual of a wildlife species that is listed as an extirpated species, an endangered species or a threatened species. Section 33: “No person shall damage or destroy the residence of one or more individuals of a wildlife species that is listed as an endangered species or a threatened species, or that is listed as an extirpated species if a recovery strategy has recommended the reintroduction of the species into the wild in Canada.”	Section 6.0 of this document discusses the management activities that will be in place to prevent impacts on wildlife species, including Species At Risk. The spatial area associated with the North Embankment Upgrade project is relatively small and will not include disturbing native habitats. However, appropriate mitigations will be used to prevent adverse impacts.

1.4 Roles and Responsibilities

The key contributors responsible for executing various work functions and making decisions during the Project are presented in Table 1.3.

Table 1.3 Roles and Responsibilities During the North Embankment Upgrade Project

Role	Responsibility
Teck Site Manager	<ul style="list-style-type: none"> • Maintain adequate staff resources to comply with the project plan and regulations • Implement and maintain mechanisms for timely response and correction to non-conformance incidents • Address issues such as non-compliances and incidents with the Teck Field Representative, Environmental Monitor, and contractor • Communicate instructions from the Teck Responsible Tailings Facility Engineer and/or Engineer of Record
Teck Contract Manager	<ul style="list-style-type: none"> • During project planning, integrate environmental requirements into design, contracts, approvals, permitting, and other plans • Provide contractors/sub-contractors the Project Plan and associated documents during the project kick-off meeting • Share lessons learned and encourage team to share lessons learned from previous projects
Teck Responsible Tailings Facility Engineer	<ul style="list-style-type: none"> • Participate in Project kickoff meeting(s) and be present during first week of construction work. • Conduct periodic site inspections over the course of construction activities to check on progress and liaise with the Engineer of Record field engineer representative and other project staff to review progress and discuss questions / concerns and technical work. • Remain informed and review ongoing progress when not on-site. • Participate in all relevant project discussions.
Teck Field Representative	<ul style="list-style-type: none"> • Support integration of environmental requirements in site activities • Implement an environmental inspection program • Liaise with Engineer of Record field representative and monitor ongoing construction works • Provide site personnel with copies of the Project Plan and present it along with other key site information at the site project kick-off meeting • Complete Initial Event Reports and follows Teck's internal reporting procedures for all reportable events • Respond in a timely manner and provide corrective actions to non-conformance incidents • Be knowledgeable of potential environmental effects of site activities and the mitigation measures, best management practices, and contingency plans to address them • Take immediate action to address, stop, or relocate activities regarded as a non-conformance • Has the authority to alter or halt works if site activity is causing unacceptable environmental damage or risk

All copies of this document are uncontrolled when printed.

Role	Responsibility
	<ul style="list-style-type: none"> Address issues such as non-compliances and incidents with the Teck Site Manager, Environmental Monitor, and contractor
Environmental Monitor	<ul style="list-style-type: none"> Be knowledgeable of potential environmental effects of site activities and the mitigation measures, best management practices, and contingency plans to address them Has the authority to issue a Stop Work order where activities are impacting, or will impact the environment (e.g., water quality, wildlife) Identify when a qualified professional must be retained, for example, bird nest surveys, and communicate and enforce set backs determined by the qualified professional. Follow up with the qualified professional for documentation of surveys. Complete daily environmental checklist to document compliance/non-compliance with the Project Plan, approvals, guidelines, regulations and any other environmental issues or potential issues Monitors construction activity to verify that works are undertaken in compliance with the appropriate sections of this CEMP, permits and regulatory requirements Provide corrective advice to the contractor Site Supervisor where appropriate, such as when non compliances are observed or imminent Measures and monitors water quality as determined by this Project Plan or regulatory requirements Addresses and closely monitors non-compliance issues immediately
Teck Manager, Environmental Performance	<ul style="list-style-type: none"> Communicate environmental and regulatory requirements to contractors Notifies regulatory agencies in the event of a reportable spill, regulatory/environmental non-compliance, or identification of a historical artefact Establish and maintain communication with environmental regulatory authorities. Liaise with regulatory agencies and stakeholders regarding environmental issues when necessary Conduct investigations of environmental or regulatory non-conformances in a timely manner
Construction Contractor Supervisor	<ul style="list-style-type: none"> Champion a culture of environmental awareness, regulatory compliance, and mandatory attendance by all site personnel to environmental training requirements and related meetings Confirm that all spills and any other events with potential for negative environmental effects are reported and documented in a timely manner Exercise or delegate authority to stop any work/activity regarded as not conforming with the Project Plan or commitments Complete all works according to approved site designs

All copies of this document are uncontrolled when printed.

Role	Responsibility
	<ul style="list-style-type: none"> • Keep training attendance records and makes them available to Teck Contract Manager • Keep a current version of the Project Plan, proposed schedule, applicable permits, and documentation on site and accessible during all construction activities • Verify that equipment is maintained and in good working condition • Address issues such as non-compliances and incidents with the Teck Field Representative • Inspects the work area during heavy rains to identify areas in need of site erosion protection • Conducts ongoing inspection of equipment for leaks • Prepares environmental incident and spill reporting forms, as required • Responsible for the successful execution of the construction activities in adherence with the project specifications and geotechnical quality control requirements as set out in the technical documents.
Engineer of Record (EOR) or Engineer	<ul style="list-style-type: none"> • Provide a design that achieves the objectives and meets regulatory requirements • Identify project footprints that allow for work to be completed safely and without excessive environmental disturbance • Remain in contact with Engineer of Record firm field representative to discuss ongoing project progress, concerns, issues, and geotechnical performance of contractor. • Participate in recurring project discussions with the Owner and Contractor. • Conduct field visit to review progress of construction activities and document findings in the project memo.
Engineer of Record firm field representative (full time)	<ul style="list-style-type: none"> • Full-time on-site geotechnical engineering supervision and quality assurance for construction of the works. • Qualified staff on-site will supervise the construction activities to document construction progress and ensure engineering design specifications are met. • Monitoring of geotechnical performance of the existing embankment during construction activities of the specified works, including following the construction TARP program as determined by the EoR. • Provide a summary of the construction activities in daily reports submitted to Teck.
All Site Personnel	<ul style="list-style-type: none"> • Participate in environmental orientation and training • Understand the environmental commitments and how to access appropriate environmental information and resources • Review and acknowledge the plan at project kick-off meeting • Comply with applicable contract documents, including the Project Plan

All copies of this document are uncontrolled when printed.

Role	Responsibility
	<ul style="list-style-type: none"> • Comply with legislative and regulatory requirements and applicable permits/approvals • Report all environmental incidents and events • Comply with the Spill Contingency Plans • Handle hazardous materials only if qualified

1.5 Document Outline

The remainder of the document is organized as follows:

- Section 2.0 – provides a description of the environmental setting of the Sä Dena Hes project area
- Section 3.0 – provides a description of the operation aspects of the development of the borrow sources
- Section 4.0 – provides a description of the plan to develop access for the North Embankment Upgrade Project
- Section 5.0 – provides a description of the North Embankment Upgrade Project activities
- Section 6.0 – provides the environmental protection plans, monitoring surveillance and reporting plan for the duration of the North Embankment Upgrade Project
- Section 7.0 – provides the Heritage Resources Protection Plan
- Section 8.0 – provides the Reclamation Plan
- Section 9.0 – provides the Spill Contingency Plan
- Section 10.0 – provides the Waste Management Plan
- Section 11.0 – provides the Sediment and Erosion Control Plan
- Section 12.0 – provides the Health and Safety Plan
- Section 13.0 – provides the North Embankment Upgrade Project schedule

2.0 Environmental Setting

The Sä Dena Hes mine site is located in the Liard Basin Ecoregion of the Boreal Cordillera Ecozone Yukon Ecoregions Working Group, 2004). The environmental features that are characteristic of the ecoregion are presented below. The environmental setting described herein is a summary of the Environmental Baseline Update and Technical Basis for Closure Assumptions, which was included as Appendix B of the DDRP (Teck 2015). The reader is referred to the DDRP for more detailed descriptions, if needed.

2.1 Climate

A meteorological station was established at the site in 2002 and operated for approximately 10 years. Since elevation is the principal control on the distribution of precipitation in the region the meteorological station data, in addition to longer-term regional data, was used to develop a precipitation model for the site. The estimated average monthly climatic data for the tailings management area are provided in Table 2.1. The mean annual precipitation is approximately 301 mm rainfall and 389 cm snowfall as water equivalent. Precipitation is common throughout the year with the driest month typically being April, and the wettest being October (Access Consulting Group, SRK Consulting and Laberge Environmental Services, 2013).

Table 2.1 Estimated Mean Monthly Climatic Data for the Tailings Management Area

Parameter	Jan	Feb	Mar	Apr	May	Jun	Jul	Aug	Sep	Oct	Nov	Dec	Year
Rainfall (mm)	2.4	0.4	0.8	2.2	24.9	45.2	60.6	59.4	64.2	36.3	3.6	1.3	301
Snowfall (cm)	60	59	46	23	9	2	0	0	7	47	60	76	389
Total Precipitation (mm)	62	60	47	25	34	47	61	60	71	83	64	78	690
Daily Maximum Temperature (°C)	-20.2	-12.3	-5.3	1.3	8.1	14.2	17.1	14.5	8.4	-0.4	-13.1	-18.0	-0.5
Daily Minimum Temperature (°C)	-31.3	-28.2	-22.6	-13.2	-3.2	1.7	5.3	3.7	-2.3	-10.1	-24.4	-27.9	-12.7
Daily Mean Temperature (°C)	-25.7	-20.3	-14.0	-6.0	2.5	7.9	11.2	9.1	3.0	-5.3	-18.7	-22.9	-6.6
Evaporation (mm)	0	0	0	0	53	105	130	99	43	0	0	0	430

From (Access Consulting Group, SRK Consulting and Laberge Environmental Services, 2013)

All copies of this document are uncontrolled when printed.

2.2 Geology and Soils

The Sä Dena Hes Property is underlain by lower Palaeozoic metasedimentary rocks, including both calcareous and non-calcareous pelitic phyllite and limestone. Limestone comprises about five percent of the stratigraphic sequence and consists of discontinuous units which are up to 100 metres thick, and which typically pinch and swell over short distances. The thicker limestone units can be traced along strike for hundreds of metres. There is evidence locally that the limestone grades laterally into calcareous phyllite. Intrusive igneous rocks on the property include three suites: mafic to intermediate, intermediate, and quartz porphyry. These intrusives are of limited size, and their age has been estimated at 50 million years. Although larger igneous bodies are not found on the property, it has been speculated that the area is underlain by a granitic pluton of the mid-Cretaceous Selwyn Plutonic Suite.

Inorganic soil deposits are primarily morainal, fluvial or glaciofluvial. Organics overlying morainal or fluvial material occur in wetlands such as the tailings management area. Upper alpine zones are bedrock while zones of colluvium occur on the steeper upland slopes.

A layer of silty loam or gravely sandy loam supports white spruce and mixed deciduous forests. These moderately well drained soils are slightly acidic to neutral (pH 6.1 to 7.3) with low to moderate organic matter and with a low level of available nutrients. Wetlands supporting black spruce vegetation have soils of mesic, fibric peat or silty loam. These poorly drained soils are slightly to strongly acidic, have high organic matter and have very little nutrients available. Alpine and subalpine vegetation is found on moderately well drained silty loam or loamy sand. These soils are slightly acid to neutral with low organic matter and with a low level of available nutrients.

2.3 Watershed and Hydrology

The Sä Dena Hes mine is located in the drainage basin of False Canyon Creek, a left bank tributary of the Frances River. False Canyon Creek has a total catchment area of 492 km² and discharges approximately 55 km above the Frances River and Liard River confluence. Access to the mine is from the south across the drainage basin of Tom Creek, a left bank tributary of the Liard River.

The Jewelbox ore zone is located near the drainage divide between Tom and False Canyon Creeks. All drainage from the Jewelbox development is directed to Camp Creek, a steep-gradient tributary of False Canyon Creek that drains the eastern flank of Mount Hundere. The former mill site is also located in the catchment of Camp Creek. The Burnick development is entirely confined in the headwaters of another False Canyon Creek tributary, which has been designated Tributary D. The tailings management area is constructed in a saddle that lies along the drainage divide between Camp Creek and Tributary E.

2.4 Vegetation

The vegetation typical for the Liard Basin Ecoregion includes boreal forest, subalpine and alpine vegetation zones with treeline at an approximate elevation of 1400 masl. Climax vegetation in the boreal forest zone is white spruce (*Picea glauca*), black spruce (*Picea mariana*), subalpine fir (*Abies lasiocarpa*) or a combination of these species. Black spruce and alpine fir are the most common boreal vegetation communities in the area. Black spruce forest is prevalent on poorly drained bogs and fens. Open stands of black and white spruce are found on upland slopes.

Paper birch (*Betula papyrifera*) occurs on moist sites throughout the area. Trembling aspen (*Populus tremuloides*) is found on well-drained south-facing slopes, and balsam poplar (*Populus balsamifera*) colonizes alluvial gravel bars and other moderately well-drained disturbed sites. Lodgepole pine (*Pinus contorta*) forms pure even-age stands in some upland areas, presumably following fire. Larch (*Larix laricina*) is found in lowland bogs along the site access road.

Willow (*Salix* spp.), alder (*Alnus crispa*), rose (*Rosa acicularis*) and Labrador tea (*Ledum groenlandicum*) are the common understory shrubs. Mountain ash (*Sorbus scopulina*) is found in the tailings management area. Ground cover is dominated primarily by kinnikinnick (*Arctostaphylos uva-ursi*), bearberry (*Arctostaphylos rubra*), crowberry (*Empetrum nigrum*), lignonberry (*Vaccinium vitis-idaea*), bunchberry (*Cornus canadensis*) and toadflax (*Geocaulon lividum*). Shrub birch (*Betula glandulosa*), along with alpine fir and willows dominate the subalpine zone. Low ericaceous shrubs are common in alpine areas, along with a groundcover of mosses and lichens.

Bluejoint reedgrass (*Calamagrostis canadensis*) is a prominent graminoid in the area, particularly in moist semi-shaded areas. Altai fescue (*Festuca altaica*) is dominant on drier slopes. Fowl bluegrass (*Poa palustris*) prevails in moist open areas. Slender wheatgrass (*Agropyron pauciflorum*), violet wheatgrass (*Agropyron violaceum*) and bearded wheatgrass (*Agropyron subsecundum*) are the primary ingress species of disturbed areas.

Legumes are not prominent in the native flora. Elegant milk vetch (*Astragalus eucosmus*) and arctic lupine (*Lupinus arcticus*) are the most common indigenous legumes in the Sä Dena Hes area.

2.5 Wildlife

The Sä Dena Hes mine site is located within the False Canyon Creek watershed and the mine access road traverses the headwaters of various tributaries of the Tom Creek watershed. The area encompasses several mature mountains with a predominance of boreal forest and limited alpine and sub-alpine terrain. This habitat is capable of supporting various ungulates, large carnivores (e.g., black bears) other furbearers and many bird species. However, species that are generally present in alpine zones are rare due to the limited availability of this habitat in the area.

Moose are the most prevalent ungulate in the area in and around the Project area, with sightings from the timberline to the valley bottoms. The Project area also provides good black bear habitat. Beaver sign has been noted along virtually all watercourses and at all lakes in the Project area. Cycles of flooding and abandonment attributable to beavers result in ponded wetlands used by many species including waterfowl.

Sä Dena Hes is outside of all Wildlife Key Areas as defined by the Government of Yukon Department of Environment. Wildlife Key Areas are geographical locations used by wildlife for critical, seasonal life functions (e.g., winter ranges, migration corridors, post-calving areas, staging areas, denning). Often animals aggregate on key areas in relatively large numbers, making populations vulnerable to disturbance or direct habitat loss. The location of Sä Dena Hes in relation to Wildlife Key Areas in the region is presented in Figure 2.1. In addition, the site is outside of the Little Rancheria and Horseranch caribou ranges.

2.6 Aquatic Resources

An Aquatic Resources Monitoring Program is conducted every two years during the low flow period (August or September) and has been conducted since 1994. A benthic invertebrate survey is conducted at six locations and a fisheries survey is conducted at two locations (MH-13 - False Canyon Creek and an unnamed tributary upstream of False Canyon Creek, MH-20). The number of monitoring locations was reduced after reclamation of the mine site. The purpose of the monitoring program is to confirm that the stream bed and substrate characterization has not changed and that a catch per unit effort is similar to previous years. In addition, benthic invertebrate community analysis, sediment and water quality samples are collected concurrently.

Pre- and post-development fish sampling indicated that fish production capabilities in the upper False Canyon Creek drainage are relatively low. The most productive area within the system appears to be the lower reaches of False Canyon Creek near the confluence with the Frances River. The fisheries data has been consistent over the years. While the absolute number of fish captured varies from year to year, the fish assemblage in the catch is consistent and is itself an indication of stability in the fish community. Slimy sculpins continued to be the dominant species captured throughout the drainage, and the only species present at MH13.

Metrics analysed to measures benthic invertebrate health indicate that water and sediment quality is contributing to a productive stream ecology. These results are consistent with historical findings from past aquatic assessments. Considering benthic indices are relatively stable across the years, it is unlikely that mine effluent is having an impact on benthic communities.

The areas where activities are planned for the North Embankment Upgrade do not support fish habitat, including the Camp Creek crossing area. This is due to the very hard and nutrient-poor water which is commensurate with mountain drainage.

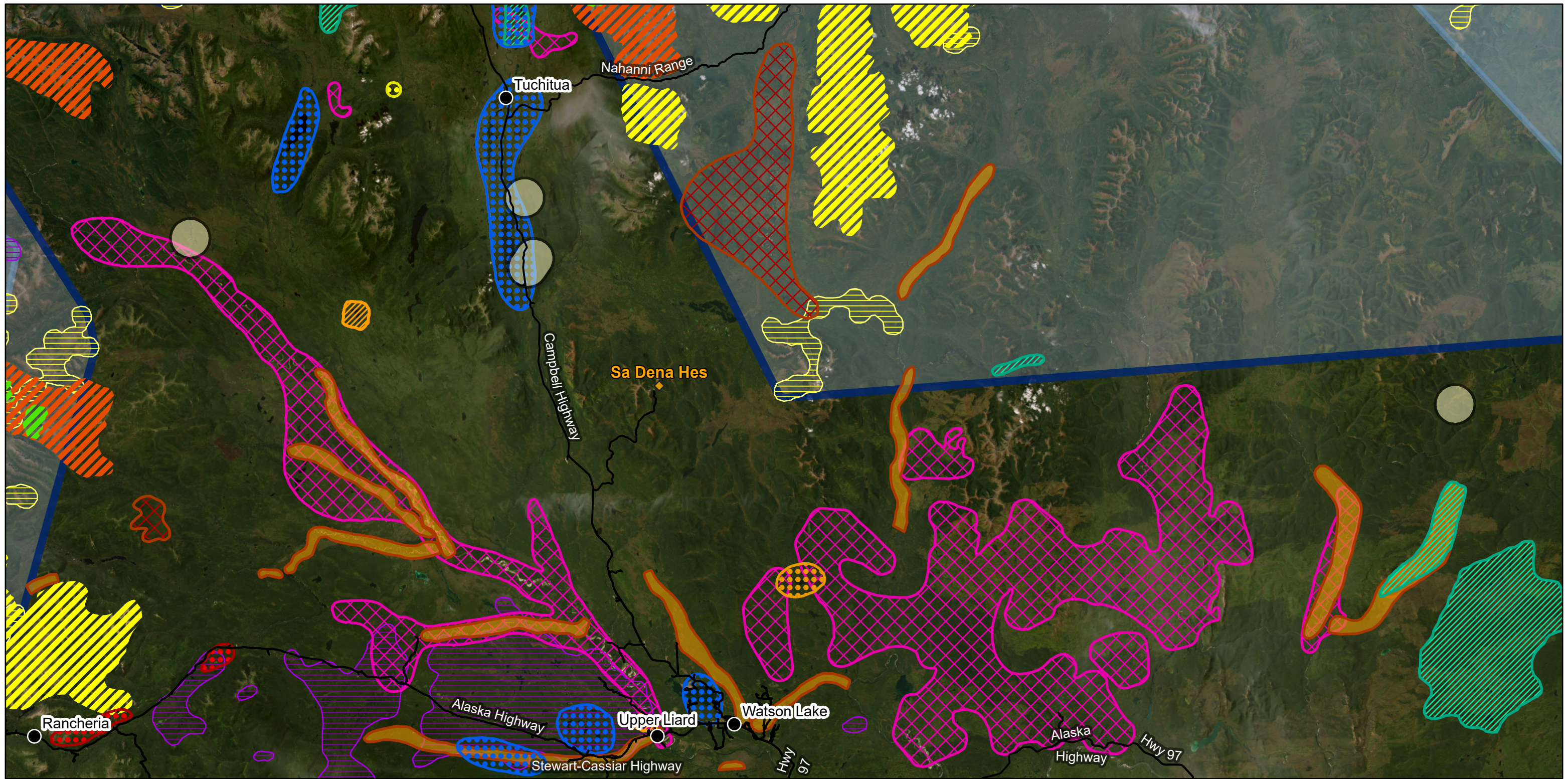

Teck

The maps and map data are provided 'as is' without any guarantee, representation, condition or warranty of any kind, either express, implied, or statutory. Teck Resources Limited assumes no liability with respect to any reliance the user places in the maps and map data, and the user assumes the entire risk as to the truth, accuracy, currency, or completeness of the information contained in the maps and map data.

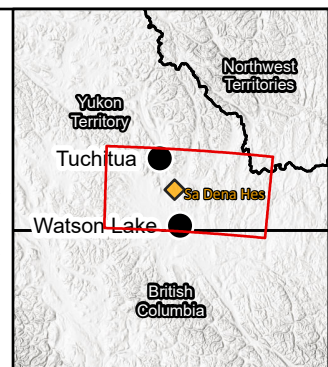

Location of Sä Dena Hes in Relation to Wildlife Key Areas in the Region

- Mountain Goat**
- All seasons and functions - survey data (Level 2)
 - All seasons and functions - survey data (Level 3)
 - All seasons and functions - local knowledge (Level 3)

- Beaver**
- Beaver (all seasons and functions)
- Moose**
- Late winter range - survey data
 - Late winter range - local knowledge

- Raptor**
- Golden Eagle
 - Bald Eagle
 - Osprey
 - Merlin
- Mineral Lick**
- Survey and or local knowledge

- Waterfowl**
- Duck - Various seasons and functions
 - Goose - Various seasons and functions
 - Swan - Various seasons and functions

- Woodland Caribou**
- Fall rut - survey data (Level 2)
 - Winter range - survey data (Level 2)
 - Fall rut (Level 3)
 - Winter range (Level 3)

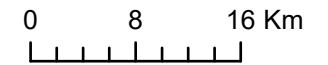

1:575,000
NAD 1983 Yukon Albers

DRAWING NUMBER
FIG 2-1

PROPERTY / SITE
SA DENA HES

DATE
2023/12/10

DRAWN BY
AM

CHECKED BY
CR

3.0 Borrow Source Development

The North Embankment Upgrade Project requires rock and till to achieve the necessary erosion protection as designed by the Engineer of Record. Rock will be obtained from a quarry that was established on the site access road for the 2014 reclamation activities. Till will be obtained from a stockpile that was created following the decommissioning of what was known as the Reclaim Dam. Development of the KM17 Quarry and the Reclaim Borrow Area are described below.

3.1 KM17 Quarry Development

A quarry (KM17 Quarry) was developed to support the reclamation activities conducted in 2014 and will be used as a borrow source once again to generate rock material to construct the Camp Creek crossing and to armour the downstream slope of the North Embankment. No clearing, stripping or additional blasting is required for the quarry development.

The quarry, which is included as authorized works in QML-0004, resides within the Eagle 108-111 quartz mineral claims YB16270-YB16273 and is located at the 17 km marker on the mine access road that stems off the Robert Campbell Highway. The location of the quarry is shown in Figure 1.2. The approximate UTM coordinates are 9V 504,400 m E, 6,703,900 m N. Rock sampled and analyzed within the quarry was demonstrated to be geochemically inert and of sufficient strength to be used for the defined Project purposes (SRK 2014). Confirmatory testing was carried out in 2024 to verify geochemical and geotechnical (material size and durability) conditions remained consistent with 2014 results.

The objectives of the 2024 investigation were:

- To estimate the volume of available rock fill at the Quarry and confirm that there is a sufficient volume of material for the project.
- Determine the particle size distribution (PSD) of the run-of-quarry material using USCS.
- Confirm suitability of the rock fill material in terms of geochemical characteristics and durability (LA abrasion testing).
- Determine the screening and/or processing requirements to meet the product specifications in the North Embankment design (SRK 2023) that have a target median particle size of 50 mm.

The test pit investigation included a set of test pits through the quarry site to collect samples for geotechnical and geochemical lab analyses. Results confirmed that adequate material will be available for the project and all geotechnical and geochemical characteristics are in line with project specifications. The rock will be quarried using an excavator, then screened and sorted to required sizes and stockpiled within the quarry footprint. A total of 2550 m³ of material is required, 2400m³ of which is needed for downstream armouring of the North Embankment (targeting 85-mm diameter) while the remaining 150 m³ is to be used as the coarse rock component (minimum 50-mm diameter) of the Camp Creek crossing.

The North Embankment armoring rock gradation requirements, as per SRK design, are as follows:

Table 3.1 North Embankment armoring rock gradation requirements, as per SRK design

Percent Passing (%)	Minimum Diameter (mm)	Target Diameter (mm)	Maximum Diameter (mm)
15	10	15	45
30	20	35	60
50	30	50	100
85	45	75	135
100	50	85	200

The Camp Creek crossing rock gradation requirements, as per SRK design, are as follows:

1. Coarse Rock used for the Camp Creek crossing shall consist of sound and durable, angular, non-acid generating quarry stone, sourced from the KM17 Quarry, and that is free from organic matter, snow, and ice.
2. The rock shall be free of fines with a minimum particle size of 50 mm. There is no maximum particle size.
3. A minimum of 1.0 m of coarse rock will be placed over the culverts.

3.2 Reclaim Borrow Area Development

There are three key elements of the Project that require the acquisition and placement of fine-grained till material. These include the following:

- The raise of the North Embankment to increase its freeboard and prevent future overtopping events, which requires an estimated 8,100 m³ of till material;
- The raise and sloping of the upstream beach area south of the embankment to drain water south from the North Embankment, which requires an estimated 7,780 m³ of till material, and;
- Placement of fill in low-lying areas on the tailings management area where ponding has been occurring, which requires an estimated 410 m³ of till material.

Till material required for the Project will be sourced from a stockpile that was created following the decommissioning of what was known as the Reclaim Dam, which took place in 2014. The location of this stockpile is shown in Figure 1.2. This stockpile contains most of the material removed from the Reclaim Dam and consists of a mixture of the “Silt Till” and “Sandy Till”. Both material types have been identified by the site’s Engineer of Record as being suitable to fulfill the Project requirements. Additionally, a comparison between the 2012 (pre-placement) and 2022 LiDAR ground surfaces indicates that there is sufficient till available.

All copies of this document are uncontrolled when printed.

Preparation of the reclaim borrow area entails the stripping and temporary stockpiling of vegetation using a dozer. An excavator will be used to dig and load the material into trucks for hauling to the tailings management area. Material loaded into trucks will be free of organic matter, frozen soil, snow, ice, and overburden soil. The total development footprint area for the reclaim borrow area will be approximately 12,450 m² and the borrow excavation will be kept above the 2012 mapped ground surface unless otherwise approved by the Engineer. Gradation control will be carried out by the EoR Field Engineer during placement, which will include visual checks and periodic confirmation gradation analyses throughout construction.

Till gradation requirements as specified by SRK are provided in Table 3.2.

Table 3.2 Till Gradation Requirement

Percent Passing (%)	Minimum Diameter (mm)	Maximum Diameter (mm)
15	0.001	0.15
30	0.004	0.7
50	0.02	4
85	0.3	65
100	5	300

4.0 Access Development Plan

Before work can begin on upgrading the North Embankment and sloping of the adjacent upstream beach, rock and till must be hauled to the embankment area. Hauling these materials will require upgrading the existing site access road and reestablishing a trail between the reclaim borrow area and the site access road. In addition, a pathway will be established on the north side of the North Embankment to allow a track-mounted drill rig access to install piezometers. These three access activities: upgrading the site access road, reestablishing a trail between the reclaim borrow area and the site access road and developing a pathway for a track-mounted drill rig are described below.

4.1 Upgrading the Site Access Road

Hauling rock between the KM17 Quarry and the North Embankment requires that the haul road, which is the site access road, meet the requirements of Section 15.43 of the Yukon Workplace Health and Safety (WHS) Regulations. The haul routes will be operated as a single-lane haul road with turnouts, shoulder berms, and runaway lanes installed as needed to meet WHS regulations requirements in accordance with the specifications outlined in the regulation. Upgrades in accordance with the WHS regulations may also include widening of the road itself, where required. The need for and extent of road upgrades will be identified by the Teck Field Representative in discussion with the contractor selected to complete the Project prior to the commencement of hauling.

Any portions of the site access road requiring upgrades to meet Yukon WHS regulations will be returned to their original state by redistributing material used to construct safety features such as berms/retardation barriers across the road surface. Any areas that require repair following the conclusion of the Project will be repaired so that the access road is left in the same or better condition as at the start of the project.

4.2 Reestablishing a Trail Between the Reclaim Borrow Area and the Site Access Road

A 1.3-km portion of a decommissioned trail that leads to the reclaim borrow area is being reestablished to haul till material to the North Embankment. Reestablishing access along this portion of the decommissioned trail will require a temporary crossing over Camp Creek. Prior to the commencement of trail clearing activities the Project Manager completed a field reconnaissance along the route to identify the existence of any terrain hazards that required further assessment and mitigation. This field reconnaissance confirmed the absence of terrain hazards that warranted further attention. An additional field reconnaissance of this route will be required prior the recommencement of project activities as a precautionary measure, to identify any changes that may have occurred since the clearing work was completed.

A Design Basis Memorandum for the Project, attached as Appendix A, outlines the design basis for the re-commissioned access trail. A summary of the works is described below.

4.2.1 Site Preparation for the Access Trail

Vegetation clearing along the trail was completed after the bird nesting period in 2024, as per approval of 2024 preparatory works by EMR. The remaining earthworks required to reestablish the trail and install the temporary creek crossing are planned to start as early as June 2025 following freshet. The reestablished trail to the reclaim borrow area will remain in place as late as October 2025 when the stream crossing will be removed to avoid ice blockage in the culverts.

Site preparation required to reestablish the access trail to the reclaim borrow area required the clearing of vegetation that has grown since it was decommissioned. Vegetation removal included the removal of overhanging branches in the path of equipment and adjacent larger trees and shrubs that present a hazard to the work area.

Areas where shoulder berms are needed will be identified in the field by the Contractor and Teck Field Representative. The Contractor will then direct a surveyor to mark the extents of all areas of work using flagging. Prior to the commencement of clearing, the Engineer will inspect these demarcated areas alongside the Contractor to identify any restrictions within or adjacent to the clearing limits. Once all work limits are confirmed the Engineer will give approval to proceed with site preparation. Clearing outside the specified or approved areas shall not be carried out without the Engineer's prior written approval. Upon receiving the Engineer's approval, the Teck Site Manager will authorize the Contractor to proceed with the clearing works.

4.2.2 Camp Creek Crossing

Reestablishing access along the 1.3 km portion of the decommissioned trail will require the installation of a temporary crossing over Camp Creek (approximately 2.0 m wide). This crossing requires the installation of a structure that will allow the creek to flow for the duration of the Project. Construction of the crossing will take place at the conclusion of freshet when the expected peak annual flows of Camp Creek have subsided. The design basis for the Camp Creek temporary crossing is summarized in Appendix A while the engineered design drawing is included in Appendix B.

A bundle of a minimum of twelve 150-mm diameter High Density Polyethylene (HDPE) pipes will be used to convey the design peak flow of 0.31 m³/s. This design considers 6-inch HDPE pipe with a Standard Dimension Ratio (SDR) of 13.5 or similar (internal pipe diameter of approximately 147 mm) with a pipe length of approximately 14.6 m. As the diameter of the pipes are relatively small there is a significant risk of ice blockage. Therefore, the crossing will be in place for one season only and the culverts and all other material will be removed prior to freezing conditions.

Prior to the crossing installation the existing riprap previously placed within Camp Creek is to be moved and/or adjusted using an excavator under direction of the Engineer to prevent any sharp rock edges from damaging the pipes. This rip rap will be set aside and returned following the crossing's removal. Following the streambed preparation, the bundled pipe will be wrapped in

geotextile, then placed on the streambed by an excavator. Each side of the pipe adjacent to the stream banks will then be backfilled simultaneously and evenly with clean coarse rock sourced from the KM17 Quarry. A minimum of 1.0 m of coarse rock (minimum 50-mm diameter) is to be placed above the culverts at a total volume of 150 m³. The coarse rock will then be covered with non-woven geotextile before approximately 75 m³ of till material is placed and compacted to form the roadbed.

The temporary crossing will be removed as soon as practicable following Project completion and prior to the onset of freezing conditions that would threaten to create ice blockages in the pipes. Using an excavator, the crossing will be disassembled in the reverse order in which it was first constructed. The roadbed till and coarse rock will be relocated by haul truck to be placed in a pre-identified location on site for immediate placement or stockpiled in a previously disturbed area for future use (i.e. future decommissioning activities). Human-made materials that are no longer of use will be hauled off site for disposal in accordance with the regulations of the Watson Lake solid waste management facility. Those materials that may be used again onsite will be hauled offsite and stored in Watson Lake. Any of the streambed rip rap that was removed in preparation for the crossing will be returned to its original location.

Once all the North Embankment work is completed, and the Reclaim borrow area has been decommissioned and revegetated, the access trail to the borrow area will be decommissioned as follows:

- Roadside-slopes are to be returned their pre-existing state.
- Existing drainage channels (swales and water bars) are to be re-established.
- The trail surface is to be de-compacted (scarified) and revegetated.

4.3 Drill Pathway

A temporary pathway, approximately 150 m in length, is required to be constructed from the east abutment of the North Embankment to the centre of its downstream slope to allow for access by a track-mounted drill rig and installation of piezometers for monitoring and data collection purposes. Minimal clearing is required for the pathway. Shrubs present will be trimmed to ground, with roots remaining in place. Till will be used to develop the access to allow for a level pathway to the piezometer installation location. This pathway is planned to be constructed as early as July 2025. Till used for the pathway will be repurposed as part of the sloping of the beach adjacent to the North Embankment.

5.0 North Embankment Upgrade Plan

The primary objectives of the detailed design of the North Embankment Upgrade are as follows:

- Raise the embankment such that overtopping is non-credible.
- Armour the downstream slope such that the embankment is protected from surficial erosion. A 1 in 1,000-year storm event should be passed without any damage and a 1 in 10,000-year flood should be passed without a tailings release.
- Reduce the volume of water that can pond immediately upstream of the embankment and within the tailings cover area

The details regarding how these objectives will be met are provided in the Design Basis Memorandum, which is provided in Appendix A. A summary is provided below.

The upgrade design consists of the following tasks which are described in more detail below and shown in Figure 5.1:

- A raise to the North Embankment by 2.3 m
- Construction of an upstream beach south of the embankment that drains away from the North Embankment at a 3% grade.
- Construction of a 0.5 m thick armouring layer on the downstream slope of the North Embankment.
- Construction of seepage collection channels downstream of the North Embankment and installation of two steel plate v-notch weirs.
- Construction of a diversion channel to the west of the North Embankment.

Placement of additional cover in areas where ponding occurs and construction of additional cover drainage swales. An already disturbed area to the west of the North Embankment will be used as a staging area. This area has been left disturbed since the 2015 reclamation works as an area for parking and staging for monitoring and maintenance activities. An office trailer, including washroom facilities and project support vehicles such as an emergency transport vehicle, pickup trucks, and heavy equipment and trailers will be placed in this location.

5.1 Embankment Raise

The North Embankment raise has been designed by the Engineer to prevent overtopping related to snow accumulation and snowmelt. A schematic from the Design Basis Memorandum is provided in Figure 5.1. To reach the design specifications, the top 15 cm of the embankment will be stripped and placed as upstream beach material. The embankment surface will then be proof-rolled prior to fill placement. Till fill from the Reclaim Borrow will be placed in 30 cm lifts and compacted with a minimum 4 passes of the compactor. Based on the original facility construction, moisture conditioning of the till is not expected to be required to meet compaction requirements. Minimum freeboard during construction is not necessary as water is not

impounded other than a seasonal (spring) pond that develops and will drain passively through the TMA prior to commencing embankment raise construction.

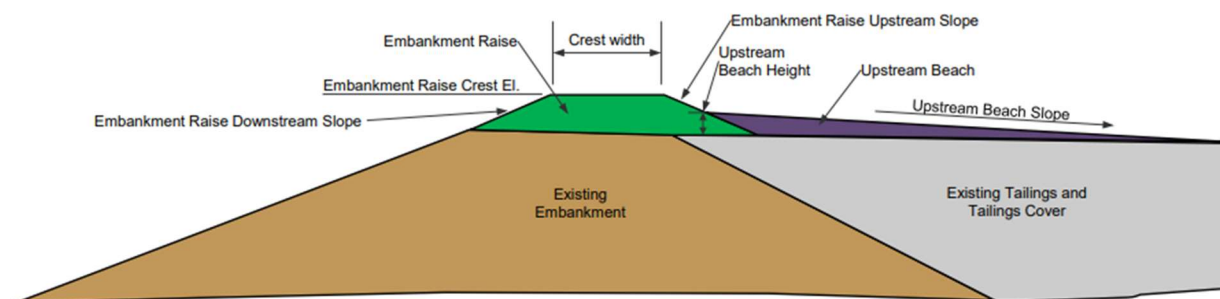

Figure 5.1 Embankment Geometry Schematic (from the Design Basis Memorandum, SRK 2023)

5.2 Upstream Beach

The purpose of the Upstream Beach is to direct rainfall and snowmelt away from the embankment. The Upstream Beach will be added south of the embankment raise with a 1 m height above the tailings cover and a 3% slope that drains to the south (Figure 5.1). Vegetation will be removed from the Upstream Beach footprint. Till will be placed in a single lift with no compaction specification (equipment weight only). The vegetation cuttings will then be spread back over the beach footprint.

5.3 Downstream Slope Erosion Protection

Erosion protection on side slopes of embankments is an important consideration for safe closure, especially for an eventual Closure Passive Care phase of the site, where significant erosion gullies could form without being detected. A design flood event was established to support the design of the erosion protection system on the slopes. The objectives of the erosion protection layer are to pass a 1 in 1,000-year storm event without any damage and pass a 1 in 10,000 flood event without a release of tailings. To achieve this, a 0.3 m thick layer of rockfill sourced from the KM17 Quarry will be placed over the downstream slope.

5.4 Seepage Weirs

New seepage weirs will be installed close to the embankment toe to improve the accuracy of seepage measurements that are used to refine quantifications of the site's water balance. The seepage weirs will be installed after the excavation of the existing seepage collection ditches downstream of the North Embankment, with the location weirs to be confirmed by the Engineer. The weirs will be centered in the seepage ditch and buried at 0.35 m into the ditch bottom. An impermeable barrier will be installed on the upstream side of the weirs using sandbags and a thin layer of geomembrane. A steel plate is to be embedded at least 0.45 m beyond the sidewalls of the ditch on both sides. The weir plates will have a v-notch, the bottom of which

All copies of this document are uncontrolled when printed.

must be at least 50 mm above the downstream water level then levelled from front-to-back and from side-to-side. Location of the v-notch weirs will be surveyed after installation.

5.5 West Abutment Diversion Channel

The existing west abutment diversion channel design allows water to flow underneath the west end of the North Embankment, presenting a significant risk of erosion and damage to the embankment during the snowmelt period and following large precipitation events. To mitigate this risk, a new diversion channel designed to divert surface water runoff away from the embankment will be excavated, replacing the existing channel.

The new diversion channel excavation will measure 89 m end-to-end and will maintain a slope of -8.5% running from South-West to North-East. Channel bottom will have a cross slope of 0% and measure 1 m across. Depth to bottom of the diversion channel will vary depending on existing ground elevations along the channel route, but a 2H:1V minimum slope will be graded from both sides of flat bottom to surface elevation. Material excavated for the new diversion channel will be used to fill in the existing west abutment diversion channel.

5.6 Tailings Cover Upgrade

The functions of the tailings cover are to prevent wind erosion of tailings and to provide a growth medium for vegetation (Teck 2015). There are areas of the cover south of the proposed upstream beach where ponded water is present during the snowmelt period and following large precipitation events. The ponding is due to a combination of inadequate grading, potential differential settlement and the scarification of the cover surface during revegetation that impeded drainage to the main drainage channel.

Till fill from the reclaim stockpile will be used to fill in low lying areas in the cover. The additional fill thickness required ranges between 0.1 and 0.2 m. Eight new shallow swales, approximately 0.2 m deep, will also be constructed to direct surface runoff to the Main Drainage Channel. Existing swales, where previous cover erosion has been observed, will be lined with erosion control blankets before the placement of a till cover. When constructing the swales a minimum cover thickness of 0.5 m will be maintained in accordance with the design criteria from the 2014 decommissioning works, meant to reduce exposure to tailings by ecological and human health receptors.

5.7 Surveillance During Construction

5.7.1 Kickoff

Prior to construction, a kickoff meeting will be held on-site. This purpose of the kickoff meeting will be to assess the site post-freshet to confirm it's suitable to begin construction activities. This kickoff meeting will be held by representatives of Teck, the EoR and their Field Representative (SRK), and key Contractor personnel. The EoR will provide a short memo summarizing the

condition including suitability to begin construction, and key discussion points during the meeting.

5.7.2 Execution

During execution, the contractor will be responsible for providing quality control as indicated in SRK's technical terms of reference for the project. SRK will provide full-time field personnel to monitor and document the works over the course of construction, including providing quality assurance. SRK will monitor the contractor's work for conformance to the technical terms of reference and compile daily reports to document the work carried out. These will include, but may not be limited to, relevant safety details, key details on work progress, testing completed, equipment on-site, select photographs, issues/concerns, and planned work for next day. These reports will be submitted to Teck's team (Site Manager, RTFE, and Project Managers). Additionally, SRK's EoR will develop a dam monitoring program including TARP for execution of the project, which the Field Engineer will follow over the course of the work. Teck will have a full-time project manager on-site during the work. The RTFE and Alternate RTFE will also visit site periodically to review site conditions and support project discussions.

5.8 Surveillance Post-Construction

The key document that will be produced to document the construction activities will be the As-Built Construction Report. This report will be produced by SRK and submitted to Teck. The as-built report will document, at minimum, the as-built geometry with a set of as-built drawings, details on design changes or deviations or issues encountered during construction and how they were addressed, details on site conditions during execution of the work, complete compilation of quality testing results from construction, summary of material volumes used, photographic logs, timeline of work, and relevant contractor records.

Following construction, the Annual Facility Performance Review (AFPR) will be carried out and will also document the condition of the completed works in this report. During this AFPR site visit (attended by Teck RTFE and SRK EoR), a full review of the completed works will be carried out. The AFPR report and conditions will be based on the completed works.

Additionally, the site caretaker will continue to review the condition of the facility during routine inspections and site visits (and event-driven inspections if necessary). A fall inspection report will be prepared by the caretaker to document the site conditions in accordance with routine monitoring for the site. During freshet 2026, existing site controls will be utilized to surveil the facility and inform timing for inspections by the caretaker.

6.0 Environmental Protection Plans, Monitoring, Surveillance and Reporting Plan

The environmental protection plans outlined in the following sections are intended to identify mitigation measures for all aspects of the project and seasonal factors that may affect the proposed works.

6.1 Vegetation Management

Construction and commissioning activities have the potential to result in impacts to vegetation and related habitat. The following best management practices will be implemented throughout the Project, to mitigate impacts to vegetation and habitat at the site:

- Identify, flag and map locations where invasive plant species are currently present, for treatment prior to construction or for avoidance to reduce the risk of proliferation.
- All machinery, equipment, and vehicles arriving on site shall be free of invasive plants, including plant parts and soil, prior to arriving on site .
- When traveling to site in vehicles or on foot from vehicle to site, crew will stay on designated roadways / paths to reduce impacts to surrounding vegetation.
- Implement soil management procedures to reduce compaction and provide sufficient coverage for subsequent seeding and/or planting. This includes matting or erosion-control, where required.
- Re-vegetate disturbed soils as soon as practical following disturbance with regionally appropriate, non-invasive, non-persistent seed mixtures or plants and use native species when possible.
- Site restoration (soil preparation and revegetating) shall use only certified weed-free seed mixes.
- Material containing invasive plants will be collected and disposed of off site.
- Vegetation clearing activities within the Project area are planned to be conducted outside the bird nesting period (assuming the 0% percent of nesting species are present), which extends from 30 April to 20 August for Zone B7 (ECCC 2023).
- Where possible, vegetation will be cut down to the ground level, leaving the root stock in place to promote more rapid revegetation.
- Removed vegetation (shrubs or trees) shall be placed on the recontoured temporary haul road and/or reclaimed stockpile borrow area. Spread evenly over the reclaimed areas, as directed by the assigned Environmental Monitor.

6.2 Water Management

- No water management is expected to be required as the TMA is designed to not retain water and no dewatering is planned.

6.3 Protection of Water Quality

Water quality will be protected through implementation of the following mitigation measures:

- In-stream works will be completed outside of high flow conditions, such as freshet or during/following storm events
- Silt fencing will be installed on the stream banks on either side of the Camp Creek crossing and parallel to the roadbed on each side of the crossing (see additional sedimentation and erosion controls in Section 11.0)
- Sedimentation control measures must be installed prior to works beginning, shall prevent release of sediment into watercourses and shall be inspected daily to confirm that they remain in good working order.
- Disturbance of riparian vegetation will be minimized by maintaining root systems when vegetation clearing is required near watercourses.
- Stabilize soil and materials along shorelines to prevent loss into water.
- All equipment working within 30 m of a watercourse, must be clean and free of deleterious substances and invasive plant species.
- Fuels and chemicals will be stored greater than 30 m from any watercourse and will include adequate secondary containment.
- Stationary equipment such as pumps used within 30 m of any watercourse will be placed in secondary containment.
- Spill kits will be available whenever chemical use or fueling occurs.
- The only fill material that should be placed in a watercourse, such as riprap, is coarse gravel and rock that is non-acid generating and non-metals leaching. It must be clear and free of fines.
- An environment monitor will be present during works in proximity to watercourses (e.g., the creek crossing) and will incorporate additional mitigation measures as needed to protect water quality.
- While work is underway in a stream (e.g., Camp Creek crossing) field water quality parameters (e.g., pH, conductivity and turbidity) will be monitored.
- Following removal of culverts, all fill materials will be removed, banks will be stabilized, restored to original shape, protected from erosion and revegetated.

6.4 Protection of Fish

No fish-bearing creeks are located within the project work areas. However, in accordance with the Federal Department of Fisheries and Oceans (DFO) best practices, water withdrawal from nearby streams for dust management will include measures to prevent fish entrainment and impingement.

A water licence is not required since less than 300 m³/day will be used for dust management. Locations of water withdrawal will be confirmed at least one month prior to withdrawal activities, but water is expected to be withdrawn from unnamed creeks in the vicinity of the North Embankment.

Fish guards will be used on intakes and will meet the following DFO criteria (DFO, 1995) to protect freshwater fish with a minimum fork length of 25 mm:

- Openings no greater than 2.54 mm.
- Screen materials may be brass, bronze, aluminum, or stainless steel.
- The open screen area and flow rate will be determined to prevent fish impingement (DFO 2020).
- The screen will be submerged so the flow distribution is uniform around the total screen area.
- The screen face will be oriented in the same direction as the flow.
- Screens should be located a minimum of 12 inches (30 cm) above the bottom of the watercourse to prevent entrainment of sediment and aquatic organisms that could be dwelling within the substrate.
- Screens will be monitored and cleaned to maintain effectiveness.
- Water pumping will be stopped if changes to the stream are identified.

6.5 Wildlife Protection Plan

The North Embankment Upgrade Project is limited to a geographically limited area within already disturbed habitat. However, wildlife may interact with the project. There are no known wildlife corridors or sensitive areas within the project footprint. To avoid and minimize potential Project-related effects on these species the following measures will be put into place:

- An Environmental Monitor will be onsite during the project to provide guidance and direction for avoiding and minimizing disturbance of wildlife habitat.
- No camps or food preparation will occur on-site.
- All project crew members working in the field will have wildlife awareness training, which includes information on predator identification, behaviours, the difference between defensive and predatory behaviour, signs of presence, and how to avoid and/or prevent an encounter with deterrents (i.e., bear spray).
- Domestic waste will be stored on-site in appropriate containers (e.g., bear-proof bins) or in equipment until properly disposed of to prevent wildlife attraction.
- Work areas will be free of garbage.
- All fuel and chemicals will be stored in locked storage facilities.
- Feeding, harming, capturing, or harassing any wildlife on site is prohibited.

- All wildlife observations (including bear scat and other bear signs) and interactions will be reported to the Environmental Monitor daily and will be included in daily environmental reports.
- Injured or deceased wildlife are to be reported to Teck Field Representative immediately.
- Teck Field Representative will contact Teck Dispatch immediately if “problem wildlife” are encountered or if mortalities are observed. The Manager, Environmental Performance (or delegate) will contact the Watson Lake Conservation Officer Services for further instructions.
- Transportation of wildlife is strictly prohibited.
- Wildlife have the right-of-way on all roads.
- Speed limits on the main access roads will be communicated to all project crew members and reinforced by the project traffic management plan.
- Collection of any wildlife parts from the mine site is prohibited, including but not limited to feathers, antlers, any parts of a carcass, teeth, fur, etc.
- No hunting, fishing or firearm possession is permitted on the mine site.
- If wildlife exhibit stressed behaviours, habituation or any other unacceptable behaviours, work will be stopped and a mitigation plan will be developed in collaboration with a qualified professional.
- Reclamation where vegetation was cleared will be completed following the project (see Section 8.0).

Additional information from Yukon Government is available¹ and will be reviewed by the Teck Representative and Contractor leads prior to beginning the program.

6.6 Bird and Nest Protection Plan

In accordance with the *Migratory Birds Convention Act*, it is illegal to destroy or disturb a bird, its egg or nest of scheduled species even when it is accidental. When possible, work that is high risk for nest disturbance (e.g., vegetation removal) will occur outside of the nesting window for the region, which extends from 30 April to 20 August for Zone B7 (assuming the 0% percent of nesting species are present) (ECCC 2023). However, since the snow-free period is limited in the region, it is anticipated that some work will be required during the period when birds may be nesting. Therefore, the following mitigations will be applied during the North Embankment Upgrade Project:

- A qualified professional will be retained to complete a nesting survey within the work area 1 to 5 days in advance (preferred less than 48 hours).

¹ <https://yukon.ca/sites/yukon.ca/files/env/env-guidelines-industrial-activity-bear-country.pdf>
<https://yukon.ca/sites/default/files/env/env-proponents-guide-human-bear-encounters.pdf>

- Equipment will be inspected daily and moved every 24-hours to prevent nesting. Physical barriers such as plastic sheeting or geocloth and preventative deterrents may be used to prevent birds from nesting on structures.
- If nesting behaviours are observed, setbacks based on the type of species, work and landscape characteristics will be set by the qualified professional and communicated to the site team by the Teck Field Representative on-site. Setbacks will be monitored and maintained for the duration of the work.
- Construction material stockpiles shall not be left with steep slopes that might encourage bank swallow nesting. All slopes will be less than 70 degrees at all times.
- The location coordinates, species, setback distance and type of observation will be recorded.
- Active nests will not be moved unless a 'Migratory Birds Damage or Danger Permit' is obtained by the qualified professional in collaboration with the Manager, Environmental Performance or designate. Note that the Canadian Wildlife Service only issues Damage or Danger permits if the presence of the nesting bird poses a real chance for damage or danger.
- Incidents that involve imminent threat, injury or death of a bird must be reported using Teck's internal reporting procedure (and subsequently the Manager, Environmental Performance). The Manager, Environmental Performance will be responsible for communication with regulatory agencies and developing a corrective action plan, as required.
- If an incident involving a bird has occurred, no one shall touch or move an injured bird unless directed to do so by the Manager, Environmental Performance, or designate.

6.7 Record Keeping

The Environmental Monitor designated for the project will conduct an environmental monitoring field checklist each day. An example of an environmental monitoring checklist is attached (Appendix C). The following types of information will be documented on the checklist:

- weather conditions,
- site activities,
- observations related to water quality, sediment and erosion observations, when applicable,
- nest surveys, including observations and mitigations applied as necessary
- wildlife (aquatic and terrestrial) observations, including observations identified by anyone on site during the project,
- incidents and non-compliances with the Project Plan, Teck operating procedures and/or regulatory requirements and conditions,
- corrective measures as applied
- photographs of observations as required

All copies of this document are uncontrolled when printed.

Monitoring field sheets will be uploaded and retained on Teck's SharePoint site. The Teck Lead, Environment (or designate) will review the field checklist daily to confirm that appropriate management and control measures are in place. All wildlife observations will be documented in Teck Legacy's GIS-referenced wildlife observation log.

7.0 Heritage Resources Protection Plan

The Heritage Resources of the mine area were previously assessed in 2013 for the reclamation activities completed in 2015 (Access Consulting Group, SRK Consulting and Laberge Environmental Services, 2013). The results of the Heritage Resource Overview were that the archaeological potential of the site is low and no zones of high or even moderate potential are in the mine area. Since the areas to be accessed for the North Embankment Upgrade are previously disturbed areas and no new disturbances are contemplated and given the low potential for archaeological resources in the area, the likelihood of uncovering resources is negligible. However, Teck Legacy Properties' Cultural Heritage Resource Chance Find Procedure (TLP-EP-002) is included in Appendix D and everyone on site will be required to review the material as part of the site onboarding training for the project in the event that a Cultural Heritage Resource is identified during the work.

8.0 Reclamation Plan

This reclamation plan for the North Embankment Upgrade Project is consistent with the objectives for reclamation and revegetation as outlined in the DDRP (Teck 2015). The current plan for the North Embankment Upgrade will also incorporate biodiversity objectives adopted by Teck since the development of the DDRP, such as using conifer and shrubs in revegetation practices instead of using agronomic cover species. Reclamation objectives include:

- Provide short and long-term erosion control.
- Aim for a final land use compatible with the surrounding lands (Wildlife Habitat).
- Leave the area on a trajectory to a self-sustaining ecosystem.
- Promote biodiversity, including species and structural diversity.
- Enhance the long-term condition and resiliency of ecosystems and biodiversity elements.
- Limit wildlife exposure to metal uptake in forage vegetation.

Completion of the North Embankment Upgrade is expected to occur in the fall. Therefore, planting of trees, shrubs, and forbs will be completed in the following spring/early summer (year 1). Graminoid seeding will occur the following year (year 2), so that the planted stock has the chance to root and become established since graminoid species can out-compete the trees for water.

Seed collection from local conifer, deciduous, shrub, and forb material shall be completed the year prior to the works so that revegetation stock is locally adapted. All collected seed will be assessed for viability at the time of collection. The final species mix will reflect local species seed availability and viability at the time of collection. Seed shall be shipped to a qualified nursery for processing. Native species graminoid seed will be sourced from commercial sources (local sources if possible) with seed mixes adapted to a northern environment.

Specific reclamation plans for each of the project areas are presented below.

8.1 Reclaim Borrow Area Access Trail

At the end of the project, the Access Trail will be decommissioned as follows:

- Remove berms and recontour road prism to restore drainage patterns to provide stability and long-term erosion control.
- De-compact running surfaces to a minimum depth of 40cm.
- Where available, coarse woody debris and/or shrubs removed during re-establishment of the access road will be spread across the recontoured/de-compacted surface.
- Revegetation will rely on regrowth and natural ingress

The Camp Creek crossing will be decommissioned by removing capping till material, coarse rock fill, geotextile, and culverts. The stream channel contours will be reestablished including

natural width and gradient, and the stream channel armoring will be maintained or improved to limit erosion. The banks will be seeded with a native grass seed mix.

8.2 Reclaim Borrow Area

The reclaim borrow area will be graded to a 2H:1V or shallower slope and the surface will be left “rough and loose” thereby generating microsites. The surface will be graded to prevent water pooling. Woody debris and shrubby debris removed to access the till material will be replaced to prevent erosion. The year following the project, trees, shrubs and forbs will be planted. Hydroseeding of graminoids will be conducted in the year after tree planting.

8.3 KM17 Quarry

The quarry will be left in a geotechnically stable state with any unused rip rap material pushed up against the high wall. Geotechnically stable state will be defined as a state that does not pose an undue risk to the public due to a failure of unconsolidated material or loose rock from above the highwall rim, and bedrock face. This will be accomplished through monitoring and assessment of site conditions during the quarry development, and both before and after the quarry remediation.

The quarry development will follow Yukon Workplace Health and Safety Regulations (Part 15). Most notably, loose rocks/unconsolidated material within 2 m of the rim of the working face will be removed to ensure that it does not fall into the excavation, and no part of the face or wall will be allowed to overhang. All the unconsolidated material beyond 2 m of the rim will be sloped to an angle less than the natural angle of repose. The quarry will be left in a geotechnical stable state with unused material pushed back up against the highwall to an angle less than the natural angle of repose. This will be done in a manner that will resemble, as much as possible, the 2015 reclamation geometry. During the quarry remediation, an SRK Engineer will visually assess the stability of the excavation to assess priority areas for backfill placement, any additional loose rock scaling, and if any additional resloping or physical barriers between the quarry and site access road are required. Any additional recommendations for post-reclamation monitoring will be made in the as-built report, if deemed necessary.

8.4 North Embankment

The beach area on the south side of the North Embankment will be constructed using till material that is left rough and loose in at least the top 40 cm to create microsites for planting. Surface variation will enhance the ability of vegetation to establish. The year following the project, trees, shrubs and forbs will be planted. Hydroseeding of graminoids will be conducted in the year after tree planting.

The piezometer access trail on the north side of the North Embankment will be revegetated through regrowth since the roots will be maintained and by natural ingress.

9.0 Spill Contingency Plan

A spill contingency for the site has been implemented according to Part D of the Water Licence QZ16-051 included in Appendix E.

9.1 Chemical Products

During the North Embankment Upgrade Project the anticipated chemical products that will be used on site include the following:

- Fuel
- Hydraulic fluid
- Bear spray
- Products required for minor equipment maintenance (e.g., WD40, windshield washer fluid)

9.2 Reportable Spill Thresholds

Spill thresholds are defined in Schedule A of the Yukon Spills Regulations. A spill in excess of the amounts specified in Schedule A of the Regulations are considered spills according to the *Environment Act* and must be reported to the Yukon Spills Report Centre (i.e., Spill Line Schedule A of the Yukon Spills Regulations is reproduced in the Sä Dena Hes Spill Contingency Plan (Appendix E). The only anticipated substances that will be on site at quantities that could result in a reportable spill are fuels. Reportable volumes for fuels are provided in Table 9.1.

Table 9.1 Reportable Spill Volumes for Fuels According to the Yukon Spills Regulation

Class	Definition	Example Substances	Reportable Amount
3	Flammable Liquids	Oil and Waste Oil	200 L
		Diesel Fuel	200 L
		Gasoline	200 L

9.3 Spill Prevention

Teck requires all employs and contractors to prevent the release of contamination to the surrounding environment and therefore, during the North Embankment Upgrade Project the following practices shall be used:

- Fuels and chemicals will be stored greater than 30 m from any watercourse
- All fuel storage, including jerry cans, will have adequate secondary containment that is regularly inspected for damage, wear and tear, and replaced as required.

All copies of this document are uncontrolled when printed.

- Any fuel-powered equipment that is stationary for more than 24 hours must have drip trays or secondary containment (e.g., collapsible containment berm)
- A spill kit will be available whenever fueling occurs and must be appropriately sized
- Spill containment, such as drip trays or other similar, must be used during fueling to contain potential spills.
- Fuel pumping or transfers will not be left unattended.

9.4 Spill Action Plan

No spill equipment is stationed at the site. Any contractor bringing products on-site must also bring spill equipment that is appropriate for the amount and type of product being brought on-site. The initial response to a spill may include the following:

- Stop work and report the spill to the Teck Field Representative, immediately when safe to do so.
- Ensure your own safety and the safety of others.
- Don personal protective equipment, such as nitrile gloves and safety glasses prior to handling spilled materials.
- Identify the spilled materials and refer to the appropriate Safety Data Sheet (SDS) to determine if human health or ignition hazards exist.
- If possible and safe to do so, immediately control (e.g., close valve) and contain (i.e., apply absorbents and berm) the spill by any safe means possible.
- Cleanup the spilled substance using available supplies from the on-site spill kits.
- If the spill is to water, use measures such as installing sorbent rolls as floating booms to contain the spill and sorbent pads to soak up the material.
- Estimate the volume of spilled material and take photos if safe to do so.
- Contact external suppliers (e.g., vacuum truck), as required.

9.5 Internal and External Reporting

All spills will be reported to the Teck Field Representative immediately when safe to do so. The Teck Representative (or designate) will phone Legacy Dispatch at 250-427-6079 and initiate an Initial Event Report. The Initial Event Report must be submitted to legacy.safety@teck.com within 2 hours of the event for all spills regardless of volume.

The Dispatch will contact the Manager, Environmental Performance and Site Manager. The Manager, Environmental Performance will review the spill details and determine whether the spill is externally reportable. Spills that exceed volumes defined in Schedule A of the Spill Regulations and any that are otherwise deemed reportable as per the Environment Act will be reported to the Yukon Spill Report Centre under the direction of the Manager, Environmental Performance.

All copies of this document are uncontrolled when printed.

- The following information will be reported:
- Location and time of the spill
- Circumstances leading up to the spill
- An approximate volume of material spilled, such as a description of the spill area and where it may have travelled
- Description of the material spilled
- Identify the spill's source from a labelled container if possible
- If source is unknown, provide any helpful information such as colour, odour, or other physical properties
- Details of any action taken at the spill site, such as containment and confinement actions, or no action taken because of safety concerns
- Description of the environment at the spill's location, such as terrain, public health concerns, nearby water bodies, and natural habitat.

10.0 Waste Management Plan

In Yukon's regulatory context, the management of domestic and industrial waste is governed by the *Environment Act* and its regulations, which address handling, transportation, disposal, and treatment of solid and special wastes. The waste management plan herein outlines the practices for handling and storage of wastes during the North Embankment Upgrade Project.

10.1 Waste Types

Limited quantities of domestic and industrial waste will be generated onsite during the North Embankment Upgrade Project activities. The handling of these wastes is described below.

10.1.1 Domestic and Construction Waste

There will be no camp accommodations on site. Therefore, domestic wastes generated during the project will be personal food waste. Crew members will be responsible for packing out all personal waste daily. An animal proof waste bin may be located in the staging area for domestic waste. The bin will be provided and managed by a reputable third-party contractor.

After the upgrades to the North Embankment have been completed, the access trail and Camp Creek crossing will be decommissioned. Geotextile materials will be discarded by hauling them off-site to the Watson Lake landfill. Culverts will be stored off site pending reuse for future reclamation activities.

10.1.2 Sewage Waste

Self-contained portable toilets will be installed within the staging area for use during the project by a third-party provider. Portable toilets are referred to as "contained privies" and regulated under the *Yukon Public Health and Safety Act Sewage Disposal Systems Regulation* (YG 1999). In accordance with section 16 of the regulation, all contained privies must be located at least:

- 1.5 m from lot boundary
- 1.5 m from any building
- 5 m from any road or driveway, and
- 15 m from any source for potable water, or natural boundary or high-water level of any water body

10.1.3 Potentially Hazardous Waste

Potentially hazardous waste that might be produced during construction activities include batteries and hydrocarbons, which are described below.

10.1.3.1 Batteries

Batteries are used for hand-held monitoring and sampling devices. Typically, lithium ion and alkaline batteries are used. Batteries of this type are considered Household Hazardous Wastes (HHW). Very few, if any, batteries are expected to be generated as waste, given the short duration of the project.

10.1.3.2 Hydrocarbons

Hydrocarbon waste generated on site is expected to be limited. No routine maintenance activities will occur on-site. Wastes may be generated from remediation of leaks or spills. Materials laden with hydrocarbons (e.g., absorbent material) and spill containment tools (e.g., drip trays) will be stored in a dedicated, labelled, and sealed 20-L pail for offsite disposal. If a leak or spill to ground were to occur, contaminated soil may be generated which will also be stored in 20-L pails. Storage of the hydrocarbon waste 20L pails will be within a bermed area at least 50 m from the any waterbody. The bermed area will be inspected regularly to confirm that the containment is in good repair.

10.2 Hazardous Waste Management

Generation of hazardous wastes such as batteries and hydrocarbon-laden materials is expected to be minimal. Wastes will be disposed at the landfill facility in Watson Lake. Landfill is a Regional Landfill with a service area “west to Swift River, south and east to the BC border, and north to Frances Lake Campground”. There is also a provisional agreement in place for accepting waste from Lower Post. Where possible, hazardous wastes will immediately disposed of offsite. If a large hydrocarbon spill were to occur, a third-party remediation contractor would be retained for proper off-site disposal.

11.0 Sediment and Erosion Control Plan

Erosion and sedimentation occur when soil surfaces are exposed (i.e., vegetation is removed) and through actions of wind or water, fine-grained material is mobilized. Fine-grained material mobilized to aquatic habitats can be detrimental to aquatic receptors, and in terrestrial environments their loss can lead to a loss in growing medium for vegetation. Works associated with the Project may have the potential to mobilize fine-grained material. Most of the activities related to the North Embankment Upgrade Project are not in the vicinity of watercourses and no watercourses within the project area are fish-bearing. A significant portion of the project will be carried out across the crest and upstream side of the North Embankment. Therefore, limited sediment and erosion control measures are anticipated to be required in these construction areas. This is due to the configuration and drainage of the TMA system which provides natural sediment control in its current state. No roads and trails are being designed or constructed for this project; therefore, no new water conveyance features will be established. Previously established access routes will be reinstated to facilitate the project. Even still, mobilization of material will be minimized and controlled in accordance with the Sediment and Erosion Control Plan Guidelines (Yukon Water Board 2018).

A sediment and erosion control plan will be required to be submitted by the Contractor and reviewed by Teck prior to beginning construction to confirm that the considerations above are included. SRK and Teck will monitor the Contractors' adherence to their program over the course of the work via daily inspections.

11.1 Erosion and Sedimentation Sources and Control Measures

Potential sources of erosion and sediment during the North Embankment Upgrade Project include the following:

- Use of quarry materials in the Camp Creek Crossing
- Removal of vegetation to reestablish the access trail to the reclaim borrow area
- Large vehicle traffic
- Removal of vegetation to construct the embankment raise and associated erosion control mitigations, such as the beach area.

The first measure for on-site control of erosion is that a trained environmental monitor will be dedicated throughout the Project to inspect work areas for the potential for erosion and to apply appropriate mitigations. Inspections and application of mitigations will be documented on the daily monitoring form (Appendix C). The following control measures will be used throughout the project:

- Effective sediment and erosion control measures will be installed before starting work to minimize potential for introduction of sediment into watercourses

- Contingency supplies of sediment and erosion control materials to be maintained at the work site; installation and maintenance of materials to be conducted by experienced workers
- Only clean rock, free of fine material, will be used to construct the Camp Creek crossing, which will then be covered by layers of geotextile material.
- Perimeter channels will be installed, as required, to catch and transport site runoff from construction sites and equipment staging areas.
- Controlling site runoff by ditching and grading as required.
- Water trucks will be used to minimize mobilization of fine-grained materials.
- Minimizing the length and steepness of bare, exposed slopes
- Shrubs and trees will be cut at the ground surface, leaving the root mass in place to stabilize the ground surface.
- Removed vegetation will be retained and spread over the cleared areas when works are completed
- Seed and/or plantings will be applied the following growing season to reestablish vegetation in cleared areas.
- Removal of sediment control measures, such as plastic sheeting and silt fencing, when no longer required, as determined by the environmental monitor.

It should be noted that project work will be continuous (i.e. no long-duration work stoppage is planned). Therefore, by following the approach as outlined in Section 6.3 on sediment and erosion protection, no additional measures are anticipated to be required.

In the event that work is stopped due to unforeseen circumstances the conditions on site will be assessed and appropriate erosion protection measures put in place prior to leaving the site.

11.2 Monitoring Strategies

During the Camp Creek crossing works, daily water quality sampling upstream and downstream of in-water construction will be required. Daily turbidity, pH and conductivity measurements will be conducted using a YSI multi-parameter probe and recorded on the Daily Environmental Inspection Checklist. Downstream data will be compared with upstream water quality values to determine whether there is evidence of water quality impairment due to construction activities.

Target: Maximum increase of 8 NTUs from upstream levels for a short-term exposure (e.g., 24-h period).

One grab sample will be collected from upstream and downstream locations and submitted for laboratory analysis of Total Suspended Solids (TSS) at least once before, during, and after construction of the crossing. An additional sample will be collected from the creek after removal of all material and restoration of the site. Laboratory results will be compared to the CCME Water Quality Guidelines for TSS.

12.0 Health and Safety

Health and safety are of the utmost importance to Teck Legacy Properties (Teck Legacy). As such, Teck Legacy continues to invest in the development and implementation of a comprehensive health and safety program that applies to all sites under its care. Teck Legacy is committed to meeting and exceeding occupational health and safety compliance requirements within the regulatory jurisdictions in which it operates, and to continuously improve its health and safety performance by:

- Fostering and promoting the core values of safety leadership amongst Teck Legacy employees and contractors.
- Implementing a risk management framework that proactively identifies high potential risks, applies critical controls to eliminate and mitigate those risk, and verifies the effectiveness of those controls.
- Supporting worker training and development.
- Building a health and safety workplace culture that is based on accountability, teamwork and engagement.
- Implementing a rigorous and comprehensive contractor management program that pre-qualifies service providers that are aligned with and dedicated to Teck Legacy's health and safety program.
- Documenting and investigating all incidents with the aim of developing measures that prevent reoccurrences.

12.1 Health and Safety Management Framework for Projects

12.1.1 Contractor Selection

The implementation of the Project-specific health and safety program will begin the selection of a competent contractors through the evaluation and validation of:

- Safety performance records from previous work, including client references.
- Established in-house safety programs, including pre-developed policies and standard operating procedures.
- Documented certifications, qualifications and other training required to carry out Project-specific tasks. This includes verification and inclusion of Yukon First Line Supervisor Certificate holders that will be onsite for the duration of the project.
- Capacity to provide required provide First Aid trained personnel, supplies and equipment that complies with Yukon Safety Regulations.

12.1.2 Pre-Project Safe Work Planning

A foundational component of Teck Legacy's pre-project planning involves the requirement to develop an Environment, Health, Safety and Communities (EHSC) Plan prior to commencement

All copies of this document are uncontrolled when printed.

of any field work. The process associated with developing EHSC Plan is intended to guide selected contractors and the Teck Legacy Project team (collectively referred to as Project personnel) through the process of completing a thorough assessments to identify hazards inherent to tasks being conducted, and those posed by site-specific conditions, including the potential influences of weather. In addition to health and safety considerations, the hazard assessment also extends to the natural environment and members of the general public.

Once hazards are identified, the EHSC Plan development process guides Project personnel through the identification of

- Controls to eliminate or minimize hazards.
- Applicable training required by Project personnel, including review and sign-off on Teck Legacy policies and standard operating procedures.
- Where specific Teck Legacy work permits and Management Plans are required
- Emergency response procedures specific to the Project that are in addition to the sites Mine Emergency Response Plan.

The EHSC Plan is first drafted by the selected contractors to strongly impart the process and resulting content. The resulting draft is then reviewed and finalized by the Teck Legacy Project Manager and Teck Legacy Health and Safety site representative. The finalized copy is then signed off as a formalized agreement between Teck Legacy and the selected contractor representatives. All workers expected to be in the field are oriented to the EHSC work plan and required to provide a signed agreement of their understanding of and adherence to the plan prior to commencement of work in the field.

It is important to note that the EHSC plan is not fully static. If new work scope is required, work conditions change or if new hazards are identified in the field an assessment of new hazards and appropriate controls must be completed and documented through an amendment to the EHSC plan that must be signed off by all the individuals that did so previously.

12.1.3 In-Field Management

Regular in-field management practices help provide a continuous reinforcement of the content and associated commitments outlined in the EHSC work plan. A tailgate safety meeting will be held at the beginning of every field day, or when the job site conditions or tasks substantially change, with all crew members. Topics of discussion during tailgate meetings include:

- Assurance that all persons onsite are signed into the site's daily tally system.
- Outlining individual tasks applicable for that day, alongside the corresponding safe work practices and procedures, as well as corresponding personal protective equipment (PPE) requirements.
- Completion of the daily Job Safety Assessment (JSA), which guides the site team through the process of identifying hazards for the tasks expected to occur that day. The JSA is

intended to be updated during the day if conditions or tasks change from the initial plan (e.g., weather).

- In-field health and safety assurance is accomplished by daily, documented inspections to verify that the critical control measures outlined by the EHSC work plan and the safe work procedures applicable to the Project are being implemented and are effectiveness.

12.2 Traffic Management

While all Teck Legacy EHSC plans require the consideration of Traffic Management Plans for in-field work programs, the prominence of hauling activities as part of this Project necessitates specific mention that one will need to be created, reviewed and signed off by all field workers and supervisors. The fundamental elements of the Traffic Management Plan will include the following:

- Rights of way
- Paths of travel
- Speed limits
- Signage
- Barricading
- Communication methods and associated protocol.

The standards articulated through the Traffic Management Plan will reflect applicable requirements as defined by Yukon WHS Regulations and Teck Legacy procedures.

12.3 Emergency Response Planning

Emergency response planning is an essential part of Teck Legacy's health and safety programs. A central Mine Emergency Response Plan (MERP) is maintained for Sä Dena Hes that meets both regulatory and industry-defined standards and is exercised on an annual basis. The MERP has been attached as Appendix F.

The top priority of this plan is to ensure the protection and preservation of life, the environment and property. The MERP contains an inventory of the hazards, both known and potential, that are inherent to the site and the corresponding risks that these hazards may present to people and the environment. Furthermore, the MERP articulates emergency response procedures and action plans corresponding to these hazards. To ensure its effectiveness the MERP is reinforced by trained personnel and resources that are currently in place to effectively deal with the potential emergencies identified within it.

Placed within the context of in-field project activities, the MERP is supported by project-specific emergency response and notification procedures that are spelled out in the project-specific EHSC work plan. This EHSC work plan will articulate the roles and responsibilities of specific Project personnel in the event of an emergency and outline the immediate actions that must be

All copies of this document are uncontrolled when printed.

taken to respond. These actions include notification requirements to project supervisors who are then responsible to provide notification to Teck Legacy's central health and safety team.

The overarching emergency response process can be summarized in three key stages, as follows:

1. Containment

This is the initial step to control an emergency, beginning from the moment a problem is discovered up until emergency response personnel are notified. At this stage, on-site personnel must be prepared to follow emergency response procedures on an immediate basis. Most emergencies are successfully contained by site personnel and do not progress beyond this stage. For major events, the containment stage may be bypassed and immediately proceed to the next stage. At the containment stage frontline supervisors must obtain precise information about the issue and evaluate the situation before they decide to initiate responses that are outlined in the MERP.

2. Notification

An emergency enters this stage if offsite assistance is needed to handle a situation or if additional notification is necessary. Frontline supervisors are responsible for alerting their own workers of the hazards and, if required, get them to safety. Once safety is assured key personnel, as outlined in the MERP, are notified to mobilize the emergency response procedures.

3. Mobilization

The mobilization stage takes effect when an Incident Command System (ICS) has been activated and the Teck Legacy emergency response team has taken over directing emergency operations. At this stage an Incident Command Centre (ICC) will be established and serve as the hub of coordination and decision-making for the emergency response. All key persons involved with the response are required to report to the ICC, which is led by an Incident Commander, a role that is typically fulfilled by the Site Manager or a qualified designate.

12.4 Site and Dam Stability

The North Embankment has performed well since construction, as documented in annual performance reports. As discussed in Section 5.0, the stability of the site will be visually assessed during project kickoff prior to commencing construction. Additionally, it is recognized that construction will introduce new loading conditions to the facility, which could induce changes to stresses and associated shears/strains/instability/consolidation, etc. The potential for construction loading to induce instability, deformations, or other risks will be assessed as part of the detailed planning for construction. This is part of SRK's current scope of work, and this assessment is planned to be completed by end of March 2025.

In 2024, a credible failure scenario assessment was completed for the north embankment. Relevant failure modes were assessed to be overtopping and internal erosion. Regarding overtopping, site presence will monitor for this potential throughout construction. It should be noted that construction will take place post-freshet, when there is no pond. Visual checks would consist of ongoing surveillance for development of a non-seasonal pond on the tailings cover. Internal erosion through the foundation is currently assessed to be credible but is a very slow developing mechanism. Visual indicators will be seepage conditions (increased volume and/or turbidity will be monitored during construction as loading is induced on the structure). This monitoring will be completed by SRK's field engineer. Both failure scenarios are low risk of causing failure during construction given the continued site presence during the project and ability for timely response during such an occurrence. Detailed Trigger Action Response Plans (TARPs) are in place for the relevant failure modes in the site's OMS Manual (Teck, 2024). These TARPs will remain in place during execution of the project work. Additionally, as previously noted, a project-specific dam monitoring plan will be developed by SRK's EoR prior to commencing construction. This will be utilized by the SRK field engineers over the course of the work. Emergency Response measures are outlined in detail in the site MERP (and summarized in the sections above).

In 2015, a runout analysis was completed (Amec Foster Wheeler, 2015). The assessment shows that the worst-case scenario could cause a runout of material into the downstream environment but remain within the property boundary. A runout from overtopping or internal erosion failure during project execution is expected to be relatively minor and remediable within a short timeframe, particularly given the readily available response resources and no presence of an upstream pond. Further details on the anticipated runout from a reasonable worst case scenario during freshet can be found in Amec Foster Wheeler, 2015). This is considered highly conservative compared to runout from an event during the project. It should be noted that following the completion of the North Embankment Upgrade, an updated runout report will be developed by SRK to document the updated reasonable worst case for relevant failure scenarios. This is expected to be available in 2026 or 2027.

13.0 Schedule

A detailed project schedule will be developed pending approval of this Project Plan and completion of the contract tendering process. A preliminary project schedule is shown in Table 13.1.

Table 13.1 Preliminary Project Schedule

Preliminary Project Dates	Description/Milestone
Regulatory Process	
March 2024	Submission of Project Environment and Operations Plan
March – August 2024	Review of Plan by Yukon Government representatives
March – August 2024	Teck addresses information requests
August 2024	Approval of Project Environment and Operations Plan
North Embankment Enhancement	
November 2023	Detailed Engineering Design Document Received
January - May 2024	Project Detailed Planning
January - June 2024	Contract Tendering Process
July 2024	Health & Safety Planning
August - October 2024	Access road and haul route upgrades and material stockpiling at KM 17 Quarry to support 2025 project execution
July - October 2025	Remaining Project Scope execution

All copies of this document are uncontrolled when printed.

14.0 Closure

If there are any questions or concerns pertaining to this report, please contact Cindy Robinson at (587) 215-6937 or cindy.robinson@teck.com.

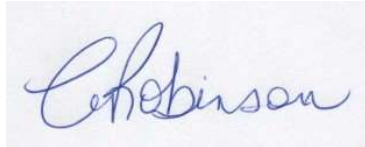
A handwritten signature in blue ink that reads "C. Robinson". The signature is written in a cursive style with a large initial 'C'.

Cindy Robinson, R.P.Bio.
Senior Supervisor, Permitting and Environment
Teck Resources Limited

15.0 References

Access Consulting Group, SRK Consulting and Laberge Environmental Services. (2013). Environmental Baseline and Technical Basis for Closure Assumptions.

Environment and Climate Change Canada (ECCC). (2023). General Nesting Periods of Migratory Birds. <https://www.canada.ca/en/environment-climate-change/services/avoiding-harm-migratory-birds/general-nesting-periods/nesting-periods.html>

Fisheries and Oceans Canada (DFO). (2020). Interim Code of Practice: End of Pipe Fish Protection Screens for Small Water Intakes in Freshwater. <https://www.dfo-mpo.gc.ca/pnw-ppe/codes/screen-ecran-eng.html>

SRK Consulting (2014). Sä Dena Hes Mine Quarry Development Plan.

SRK Consulting (2023). Design Basis Memorandum – North Embankment Upgrades.

Teck Resources Ltd. (Teck). (2015). Sä Dena Hes Mine Detailed Decommissioning & Reclamation Plan (DDRP) Updated August 2015.

Yukon Ecoregions Working Group. (2004) Liard Basin. In: Ecoregions of the Yukon Territory: Biophysical Properties of Yukon Landscapes, C.A.S. Smith, J. C. Meikle and C. F. Roots (eds.) p. 241-248. Summerland: Agriculture and Agri-Foods Canada. PARC Technical Bulletin No. 04.01.

Yukon Government (YG) (1999). Yukon Public Health and Safety Act Sewage Disposal Systems Regulations. <https://www.canlii.org/en/yk/laws/regu/yoic-1999-82/latest/yoic-1999-82.html>

Yukon Water Board and Yukon Energy. (2013). Plan Requirement Guidance for Quartz Mining Projects. <https://www.yukonwaterboard.ca/forms/quartz/Plan%20Requirement%20Guideline%20for%20Quartz%20Mining%20Projects%20-%20August%202013-kh.pdf>

Yukon Water Board. 2018. Sediment and Erosion Control Plan Guidelines. <https://www.yukonwaterboard.ca/forms/V2%20Final%20-%20Sediment%20and%20Erosion%20Control%20Guidelines%20v.2%20July%202018.pdf>

APPENDIX A
DESIGN BASIS MEMORANDUM

Revision C – Issued for Permitting

Design Basis Memorandum

To Morgan Lypka, RTFE
From Ignacio Cueto
Peter Mikes, P.Eng.
Cc
Subject North Embankment Upgrades - Design Basis

Client Teck Resources Ltd.
Project CAPR002522
Date November 29, 2023

File name: 2023-11-29_SDH-NorthEmbUpgrade_Design Basis_CAPR002522_RevC.docx

1 Introduction

SRK Consulting (Canada) Inc. has been retained to provide engineering support for the upgrades to the North Embankment of the Tailings Management Area (TMA) at the Sä Dena Hes (SDH) Property in the Yukon Territory.

This Design Basis Memorandum (DBM) describes the design basis for the proposed upgrades. A separate “Design Basis Report” (DBR) for the TMA is currently under development that presents the key information and design basis for the existing TMA (SRK 2023a). For simplicity, this design basis memo (DBM) presents only the relevant details for the North Embankment Upgrades. Once the DBR and DBM are both reviewed and accepted by Teck, the contents of this DBM will be incorporated into the DBR.

Table 1-1: Revision History

Rev.	Status	Rev. Date	Revision Memo	Prepared By	Reviewed by
A	IFR	Jul. 5/23	Issued for Discussion	IC	PM
B	IFR	Oct. 13/23	Issued for Review	PM	IC
C	IFP	Nov. 29/23	Issued for Permitting	PM	IC

2 Project Background

An erosion gully developed on the North Embankment¹ in June 2022 that required repairs. The erosion was caused by ponded snow melt water overtopping the embankment due to ineffective drainage to the south. The as-built report of the repairs (SRK 2023b) recommended to raise the North Embankment to provide adequate freeboard that will eliminate the risk of overtopping in the future.

A web-conference call was held with Teck on April 19, 2023, to present a screening assessment of potential remediation methods and five conceptual options for upgrading the embankment. The discussions determined that the preferred approach is to raise the embankment with till from the Reclaim Stockpile and to construct an ‘upstream beach’ with till to direct rainfall and snow melt away from the embankment. Through subsequent discussions with Teck and the Independent Tailings Review Board, it was determined that additional measures to minimize the volume of ponded water on the cover should be explored as part of the upgrades (e.g., construction of additional swales and/or additional cover placement).

SRK’s scope of work is detailed in a proposal dated February 16, 2023, and includes the following major tasks:

- Freeboard assessment used to determine the height of the embankment raise.
- Culvert sizing for the temporary crossing of Camp Creek that is needed to establish a haul route between the North Embankment and the Reclaim Stockpile.
- A review of the cover surface to determine areas where additional fill may be placed to reduce the amount of ponding during the snowmelt period.
- Completion of a stability analysis to evaluate the performance of the facility against extreme loading conditions as per the GISTM.
- Preparation of Issued-for-construction (IFC) engineering drawings and technical specifications.
- Preparation of a design basis memorandum and Class 3 cost estimate.

The following additional design components were later added to the design scope:

- Design of an erosion protection armouring layer on the downstream slope of the North Embankment.
- Design of additional seepage monitoring and piezometer instrumentation.

The following tasks are currently excluded from SRK’s scope of work:

- Borrow area characterization and any other geotechnical investigation: A comparison of 2012 and 2022 indicates that there is a sufficient amount of suitable till available from the stockpile from the decommissioned Reclaim Dam. An additional investigation to confirm there is sufficient erosion protection material at the KM17 Quarry is recommended to be completed.

¹ Formerly called the North Dam.

- Haul road design: It is assumed that all upgrades to the haul roads will be field fit by the contractor (except for the culvert crossing of Camp Creek).

3 Reference Information

3.1 Design and Key Technical Reports

A listing of key design reports and knowledge base documents for the TMA can be found in SRK (2023a).

3.2 Key Regulatory Permits Standards and Guidelines

The site is regulated under Quartz Mining Licence QML-0004 and management of water is regulated by Water Use Licence QZ16-051. Both licenses approved the “Detailed Decommissioning and Reclamation Plan (DDRP) prepared by Teck (2015) that was implemented in 2014.

The work is to be completed in accordance with the following documents:

- Yukon Occupational Health and Safety Act and Regulations (Yukon 2021)
- Plan Requirement Guidance for Quartz Mining Projects (Yukon 2013)
- Teck’s Tailings and Water Retaining Structure Guideline and Policy (Teck 2019)
- Global Industry Standard on Tailings Management (GISTM 2020)
- ICMM Tailings Management: Good Practice Guide (ICMM 2021)
- Canadian Dam Association Dam Safety Guidelines (CDA 2013) and the associated Technical Bulletin: Application of Dam Safety Guidelines to Mining Dams (CDA 2019)
- Developing an Operation, Maintenance, and Surveillance Manual for Tailings and Water Management Facilities (MAC 2021)

3.3 Teck Corporate Policy on Consequence Classification

Teck is committed to the safe and environmentally responsible management of tailings facilities throughout the mining life cycle to minimize harm to the environment and protect the health and safety of our people and surrounding Communities of Interest. This commitment includes the implementation of the Global Industry Standard on Tailings Management (GISTM) and industry-leading guidelines established by the International Council on Mining and Metals (ICMM), the Mining Association of Canada (MAC) and Canadian Dam Association (CDA).

For the purpose of assigning a dam classification, the consequences of potential failure modes are assessed as per the Canadian Dam Association (CDA) guidelines and the requirements of the jurisdictions in which we operate. The Global Industry Standard on Tailings Management (GISTM)

bases consequence classification on credible failure modes only, which may result in a lower stated classification.

As part of Teck's commitment to the safety of tailings facilities, Teck has adopted using extreme loading criteria for any new facilities with a credible catastrophic flow failure mode, regardless of consequence classification. Risk assessments are performed for all tailings facilities, with the objective of reducing risks to As Low As Reasonably Practicable (ALARP). In some cases, this results in further risk reduction beyond applicable regulatory requirements and is consistent with the GISTM and industry-leading best practice.

4 Design Basis and Considerations

4.1 Objectives

The primary objectives of the detailed design are:

- Raise the embankment such that overtopping is non-credible.
- Armour the downstream slope such that the embankment is protected from surficial erosion. A 1 in 1,000-year storm event should be passed without any damage and a 1 in 10,000-year flood should be passed without a tailings release.
- Reduce the volume of water that can pond immediately upstream of the embankment and within the tailings cover area.

4.2 Survey Datum

The current site datum is UTM NAD83 CSRS Zone 9.

SRK (2023a) provides a list of all relevant site surveys. For the embankment design, the June 2022 drone LiDAR survey completed by Underhill of the tailings cover and north embankment will be relied upon. For areas outside of the June 2022 survey limit, the 2022 site-wide LiDAR survey will be used. The June 2022 LiDAR survey of the North Embankment is preferred because the survey was tied into the North Embankment instrumentation and is believed to be more accurate.

4.3 Climate and Meteorology

An update of the hydrometeorological characterization of the site was completed in 2023 (SRK 2023c) and will be relied upon for the determination of the embankment freeboard and Camp Creek culvert sizing.

4.4 Seismicity and Seismic Design Requirements

A probabilistic seismic hazard assessment (PSHA) was completed in 2022 by SRK and is currently being updated with the latest public information from National Resources Canada. The target earthquake level will be the mean 1 in 10,000-year seismic event.

4.5 TMA Surface Water Management

Note: Design criteria related to the Haul Road and Camp Creek Crossing is presented in Sections 4.10 and 4.11.

Design Flood

The target inflow design flood (IDF) level is selected according to GISTM (2020) for a passive care status and is the 1 in 10,000-year flood event.

The precipitation and snowmelt values that contribute to the IDF will be obtained from the recent Hydrometeorological Characterization Report (SRK 2023c).

Design Freeboard

The freeboard design criteria will be based on CDA Dam Safety Guidelines (CDA 2013). As per CDA (2013), the crest level should be set so that the structure is protected against the most critical of the following two cases:

1. No overtopping by 95% of the waves caused by the most critical wind with a frequency of 1/1,000-year when the reservoir is at its maximum normal elevation.
2. No overtopping by 95% of the waves caused by the most critical wind when the reservoir is at its maximum extreme level during the passage of the IDF.

For the North Embankment, Case 1 does not apply because the facility does not normally impound water. For Case two, the critical wind is defined as a 1 in 2-year event (for high, very high, and extreme consequence structures).

As the potential for overtopping of the embankment is related to snow accumulation and snowmelt, the flood event for the freeboard criteria will be based on the maximum of the following two cases (based on per CDA (2013)).

1. A flood computed with spring 1 in 10,000-year rain event and snow accumulation with a frequency of 1:100 years.
2. A flood computed with the 1 in 10,000-year snow accumulation and a rainstorm with a frequency of 1:100 years.

The criteria and considerations to be used in the freeboard calculations are summarized in Table 4-1. All climate parameters consider climate change.

Table 4-1: Freeboard Design Criteria

No.	Item	Value/Description	Design Input	Source/Reference	Comments
1	Datum	The freeboard will be defined as the elevation difference between the top of the upstream beach and the crest of the embankment	A	SRK	
2	Freeboard safety factor allowance	0.5 m	P	SRK	
3	Wind speed criteria	1 in 2-year, 1 hour duration	C	CDA (2013)	
4	Historical hourly average wind speed (1 in 2 year)	12.5 m/s (45 km/hr)	P	SRK (2023c)	Given the small pond size and shallow depth, wave run-up due to wind is negligible.
	Historical wind gust speed (1 in 2 year))	19.4 m/s (69.8 km/hr)	P	ECCC	Gust speed measured at Watson Lake (2003 – 2022)
5	1 in 10,000-year precipitation in 24 hours (inc. climate change)	134 mm	P	SRK	See Hydrotech. Design Memo (Table 3)
6	1 in 100-year precipitation in 24 hours (inc. climate change)	83 mm	P	SRK	See Hydrotech. Design Memo (Table 3)
7	1 in 100-year snowpack depth	378 mm (SWE) Historical 461 mm (SWE) with Climate change	P	Historical value from SRK (2023c) Table 4.4-18	Climate change value based on a climate change factor of 22% as estimated in Table 4 in the Hydrotech Design Memo.
8	1 in 10,000-year snowpack depth	539 mm (SWE) Historical 658 mm (SWE) with Climate change.	P	Historical value from SRK (2023c) Table 4.4-18	Climate change value based on a climate change factor of 22% as estimated in Table 4 in the Hydrotech Design Memo.
9	Controlling freeboard criteria	1 in 10,000-yr snowpack plus the 100-year precipitation event	C		
10	Required Freeboard	0.74 m	P	SRK	(No. 6 plus No. 8) Excludes freeboard safety factor allowance
11	Design Freeboard	1.24 m	P	SRK	(No. 2 plus No. 10)

Notes:

- ¹ Technical Criteria (C): an established norm or requirement.
- ² Objectives (O): a specific result to be achieved based on verifiable evidence or facts.
- ³ Parameters (P): a defining characteristic.
- ⁴ Assumptions (A): considered adequate with the appropriate level of accuracy; should be confirmed during the engineering process.

Erosion protection

Erosion protection on side slopes of the dams is an important consideration for safe closure, especially for the Closure -Passive Care Phase, where significant erosion gullies could form without being detected. A design flood event must be established to support the design of the erosion protection system on the slopes (from vegetation to rockfill).

As noted in Section 4.1, the objectives of the erosion protection layer are to:

1. Pass the 1 in 1,000-year storm event without any damage.
2. Pass the 1 in 10,000-year flood event without a tailings release.

The criteria and considerations to be used in the downstream erosion protection calculations are summarized in Table 4-2. All climate parameters are to consider climate change.

Table 4-2: Erosion Protection Design Criteria

No.	Item	Value/Description	Design Input	Source/Reference	Comments
1	Serviceability IDF	1 in 1,000-year flood event.	C		24-hour event.
2	Design IDF	1 in 10,000-year flood event.	C	GISTM (2020)	24-hour event.
3	1 in 1,000-year rainfall (inc. climate change)	108 mm	P	SRK	See Table 3 in Hydrotech Design Memo.
4	1 in 1,000-year snowmelt (inc. climate change)	59 mm	P	SRK (2023c)	Historical Value (51mm) from Table 4.4-20; climate change factor (15.2%) from Section 6.6.
5	1 in 10,000-year rainfall (inc. climate change)	134 mm	P	SRK	See Table 3 in Hydrotech Design Memo.
6	1 in 10,000-year snowmelt (inc. climate change)	64.5 mm	P	SRK (2023c)	Historical Value (56mm) from Table 4.4-20; climate change factor (15.2%) from Section 6.6.
7	Modelled Unit flow (1 in 1,000-year flood event)	0.004 m ³ /s/m	P	SRK	See Section 4 in Hydrotech Design Memo.
8	Modelled Unit flow (1 in 10,000-year flood event)	0.005 m ³ /s/m	P	SRK	See Section 4 in Hydrotech Design Memo.
9	Serviceability Particle Size Distribution	D ₁₅ = 10 mm D ₃₀ = 20 mm D ₅₀ = 30 mm D ₈₅ = 45 mm D ₁₀₀ = 50 mm	P	SRK	Minimum acceptable particle size distribution to meet serviceability requirements (1 in 1,000-yr event).
10	Design Particle Size Distribution	D ₁₅ = 15 mm D ₃₀ = 35 mm D ₅₀ = 50 mm D ₈₅ = 75 mm D ₁₀₀ = 85 mm	P	SRK	
11	Armour thickness	0.3 m	A	SRK	

Notes:

- ¹ Technical Criteria (C): an established norm or requirement.
- ² Objectives (O): a specific result to be achieved based on verifiable evidence or facts.
- ³ Parameters (P): a defining characteristic.
- ⁴ Assumptions (A): considered adequate with the appropriate level of accuracy; should be confirmed during the engineering process.

4.6 Embankment Raise Characteristics

Geometry

The geometry of the embankment raise geometry is summarized in Table 4-3. Figure 1 below provides a schematic figure that defines the table parameters.

Table 4-3: Embankment Geometry Design Criteria

No.	Item	Value/Description	Design Input	Source/Reference	Comments
1	Embankment crest elevation	1,102.3 m	P	SRK	Current crest el. = 1,100 m
2	Crest width	8 m	A	SRK	
3	Upstream beach height	1 m	A	SRK	
4	Upstream beach slope	3%	A	SRK	
5	Embankment raise downstream slope	2.5H:1V	A	SRK	To match existing slope
6	Embankment raise upstream slope	2.5H:1V	A	SRK	Slope above the upstream beach.
7	Revegetation	Reclamation Plan to be completed by Teck.	P	SRK	

Notes:

- ¹ Technical Criteria (C): an established norm or requirement.
- ² Objectives (O): a specific result to be achieved based on verifiable evidence or facts.
- ³ Parameters (P): a defining characteristic.
- ⁴ Assumptions (A): considered adequate with the appropriate level of accuracy; should be confirmed during the engineering process.

Figure 1: Embankment Geometry Schematic

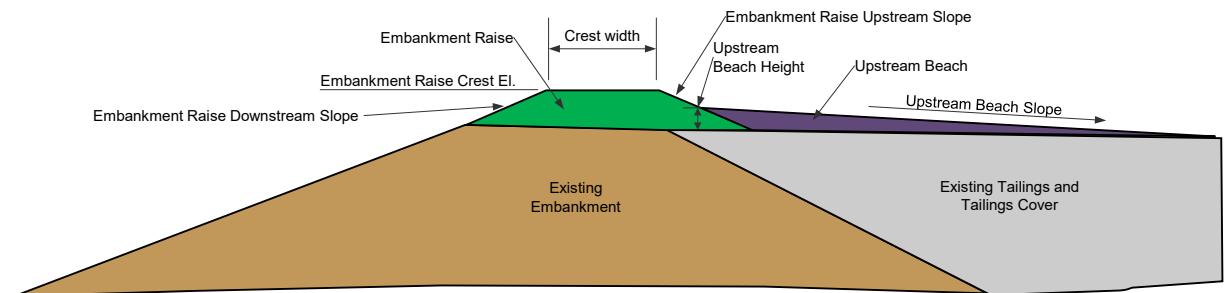

Sources: <https://srk.sharepoint.com/sites/NACAPR002522/Deliverables/Design%20Basis/Figures/geometry%20schematic.pptx?web=1>

Fill Material

It is assumed that till material will be available from Borrow Area G (Reclaim Dam Stockpile). This stockpile contains most of the material removed from the Reclaim Dam (AMEC 2015) and consists of a mixture of the “Silt Till” and “Sandy Till”. Both material types are suitable for the embankment and upstream beach construction.

4.7 Geotechnical Design

Liquefaction Assessment

In the SRK North Embankment PFM Review (SRK 2023d) Appendix A, a liquefaction assessment on the foundation of the TMA was done for the mean 1 in 10,000-year PGA. This assessment showed that the North Embankment foundation is not susceptible to liquefaction.

The assessment will be updated with the latest available results of the PSHA (currently in progress).

Slope Stability

A limit equilibrium stability analysis will be undertaken for the North Embankment. The design cases will be based on CDA Safety Guidelines (CDA 2019) design cases and are summarized in Table 4-4. Material properties, phreatic surface and model geometries used in the assessment will be the same as those used in the most recent stability analysis completed for the dam (SRK 2023d).

Given that the upstream slope of the North Embankment is covered with tailings, only the downstream stability needs to be assessed. The seismic loading will also be assessed using a critical seismic coefficient of 0.074 yield coefficient (horizontal seismic coefficient that yields a FOS = 1.0) based on a Site Class C designation.

Table 4-4: Stability Analysis Cases

Load Case	Slope	Minimum Factor of Safety
Long-term static	Downstream	1.5
Post-seismic	Downstream	1.2

Notes:

¹ The pseudo-static analysis will be completed using the Hynes-Griffin and Franklin (1984) methodology that applies a seismic coefficient equal to 50% of the bedrock PGA and applies a strength reduction factor of 0.8 to all materials.

² If required based on the results of the liquefaction assessment.

4.8 Tailings Cover Drainage Improvements

The functions of the tailings cover are to prevent wind erosion of tailings and to provide a growth medium for vegetation (Teck 2015). There are areas of the cover south of the proposed upstream beach where ponded water is present during the snowmelt period and following large precipitation events. The ponding is due to a combination of inadequate grading, potential differential settlement,

and the scarification of the cover surface during revegetation that impede drainage to the main drainage channel.

During the design, SRK will review the 2022 LIDAR survey to identify areas where additional fill or swales could be constructed to minimize the ponding while maintaining a minimum cover thickness of 0.5 m. The 0.5 m minimum thickness is the design criteria from the 2014 decommissioning works to reduce the risks to ecological and human health receptors from metal contaminants.

4.9 Earthworks and Constructability

Table 4.5 summarizes the earthworks and constructability requirements for the project.

Table 4-5: Earthworks and Constructability Design Criteria

No.	Item	Value/Description	Design Input	Source/Reference
1	Foundation Preparation	<ul style="list-style-type: none"> ■ Entire footprint to be stripped of organics and loose surficial soils removed (150mm depth). ■ Within the embankment raise footprint, the area is to be proof-rolled and scarified prior to fill placement. 	C	SRK
2	Fill placement – Embankment Raise	<ul style="list-style-type: none"> ■ Till material will be placed in maximum 0.3 m lifts and be compacted to at least 95% of the Modified Proctor maximum dry density (as per the original dam construction) 	C	SRK
3	Fill placement – Upstream Beach	<ul style="list-style-type: none"> ■ The till material may be placed in maximum 0.45 m lifts and compacted under dozer equipment weight only. 	C	SRK
4	Compaction Control	<ul style="list-style-type: none"> ■ At the start of fill placement, a nuclear densometer is to be used to establish a performance specification for compaction. ■ A minimum of three additional visits by a nuclear densometer technician is recommended to ensure that placed fill meets the performance specification throughout construction. 	A	SRK
5	Gradation Control	<ul style="list-style-type: none"> ■ Daily visual field checks by the Site Engineer are to be completed to confirm that the borrow material used is Till and not Sand and Gravel. ■ A minimum of 12 confirmation gradation analysis are to be collected throughout construction at approximately equal intervals of the total construction volume. 	A	SRK

Notes:

- ¹ Technical Criteria (C): an established norm or requirement.
- ² Objectives (O): a specific result to be achieved based on verifiable evidence or facts.
- ³ Parameters (P): a defining characteristic.
- ⁴ Assumptions (A): considered adequate with the appropriate level of accuracy; should be confirmed during the engineering process.

4.10 Additional Instrumentation

Table 4-6 summarizes the considerations and design criteria for additional North Embankment Instrumentation. This additional instrumentation is based on recommendations resulting from the 2023 site inspection and discussions with the ITRB.

Table 4-6: Additional Instrumentation Design Basis

No.	Item	Value/Description	Design Input	Source/Reference	Comments
1	Seepage Monitoring Locations	1	A	SRK	New seepage weir to be installed close to the embankment toe to improve the accurate of the seepage estimate.
2	Seepage Monitoring Type	v-notch steel plates and water level data loggers	A	SRK	
3	Tailings phreatic surface piezometer locations	3	A	SRK	6 VWP's piezometers to be installed in the tailings and foundation along sections aligned with the existing piezometers to determine the phreatic level in the tailings and improve the understanding of the seepage regime through the North Embankment.
4	Downstream slope piezometer locations	1	A	SRK	2 VWP's to be installed to measure the phreatic surface in the embankment and foundation approximately mid-slope along the section at the maximum embankment height. The purpose of these piezometers is to improve the understanding of the horizontal and vertical seepage gradients through the North Embankment.
5	Piezometer types	VWP	P	SRK	Vibrating wire piezometers with data loggers.

Notes:

- ¹ Technical Criteria (C): an established norm or requirement.
- ² Objectives (O): a specific result to be achieved based on verifiable evidence or facts.
- ³ Parameters (P): a defining characteristic.
- ⁴ Assumptions (A): considered adequate with the appropriate level of accuracy; should be confirmed during the engineering process.

4.11 Haul Road Design

A haul road is required between the North Embankment and the Reclaim Stockpile. The haul route will partially follow the existing site access road to the North Embankment. A 1.3 km long decommissioned access road to the Reclaim stockpile will require to be reestablished, which will also require a temporary culvert to cross Camp Creek.

The haul road is required to meet the following Yukon Occupational Health and Safety (OHS) Regulation (15.43) requirements:

Haul Road Width:

- (a) a travel width
 - i. not less than three times the widest haulage vehicle used where dual lane traffic exists
 - ii. not less than two times the widest haulage vehicle used where only single lane traffic exists.

Haul Road Berm:

- (b) a shoulder barrier or berm
 - i. at least three quarters of the height of the largest tire on any vehicle hauling on road
 - ii. located and maintained along the edge of the haulage road wherever a drop-off greater than 3 m exists.

Runaway lane:

(3) Clearly marked emergency runaway lanes or retardation barriers shall be provided and maintained at suitable locations and be capable of safely bringing a runaway vehicle to a stop, where the road grade exceeds 5%.

Table 4-7 summarizes the haul road design basis for the re-commissioned access road. The existing site access road may also require to be widened in selected areas and berms added to meet Yukon OHS requirements.

Table 4-7: Haul Road Design Basis

No.	Item	Value/Description	Design Input	Source/Reference	Comments
1	Design vehicle	CAT 740	A	SRK	
2	Truck width	3.43 m	P	CAT	CAT Handbook
3	Tire height	1.82	P	CAT	CAT Handbook
4	Traffic	Single lane	A	SRK	Truck turnouts to be established at locations directed by Teck/Contractor.
5	Road width	6.86 m	P	SRK	Excludes width needed for any shoulder berms.
6	Shoulder berms	TBD	A	SRK	Teck/Contractor will be responsible for determining where shoulder berms are required.
7	Min. Shoulder berm height	1.4 m	P	SRK	

No.	Item	Value/Description	Design Input	Source/Reference	Comments
8	Berm base width	2.8 m	A	SRK	
9	Runaway lanes and/or retardation barriers	TBD	A	SRK	Teck/Contractor will be responsible for determining where runaway lanes and/or retardation barriers are required.
E	Maximum design grade	15%	A	SRK	(for Camp Creek Crossing Design). Otherwise, road will follow the existing grade.

Notes:

- ¹ Technical Criteria (C): an established norm or requirement.
- ² Objectives (O): a specific result to be achieved based on verifiable evidence or facts.
- ³ Parameters (P): a defining characteristic.
- ⁴ Assumptions (A): considered adequate with the appropriate level of accuracy; should be confirmed during the engineering process.

4.12 Temporary Camp Creek Crossing Design

To provide access to machinery and equipment a temporary crossing at the camp creek is planned. This crossing will involve the need for a culvert to keep the creek running during the North Embankment works. The works will be carried out during summer and are estimated to have a duration of 2 to 3 months.

Table 4-8 summarizes the design basis for the Camp Creek culvert design.

Table 4-8: Design Basis – Camp Creek Crossing

No.	Item	Value/Description	Design Input	Source/Reference	Comments
1	Crossing type	Culvert	A	SRK	
1	Needed duration	3 months	A	SRK	(July through September)
2	Inflow Design Flood (IDF)	1:10 years	C	SRK	Based on summer/fall flows
3	IDF peak flow (m ³ /s)	0.31	P	SRK	See Hydrotechnical Design Memo for further details.
4	Culvert type	Open-profile HDPE	A	SRK	
5	Culvert diameter	150 mm	A	Teck	Diameter recommended by Teck based on local availability.
6	# of culverts	12	P	SRK	See Hydrotechnical Design Memo for further details.
7	Minimum fill height over culvert	1.0 m	P	SRK	See Hydrotechnical Design Memo for further details.

Notes:

- ¹ Technical Criteria (C): an established norm or requirement.

- ² Objectives (O): a specific result to be achieved based on verifiable evidence or facts.
- ³ Parameters (P): a defining characteristic.
- ⁴ Assumptions (A): considered adequate with the appropriate level of accuracy; should be confirmed during the engineering process.

Fill material around the culvert is assumed to be locally sourced.

4.13 Reclaim Stockpile Borrow Area

Table 4-9 presents the design basis for the development and decommissioning of the Reclaim Stockpile Borrow Area. An erosion and sediment control plan for the borrow area will be developed by Teck.

Table 4-9: Design Basis – Reclaim Stockpile Borrow Area

No.	Item	Value/Description	Design Input	Source/Reference
1	Site Preparation	<ul style="list-style-type: none"> ■ Vegetation is to be removed and stockpiled for reclamation 	A	SRK
2	Excavation	<ul style="list-style-type: none"> ■ The borrow is to be excavated in a manner that will not pool water. 	A	SRK
3	Decommissioning	<ul style="list-style-type: none"> ■ All slopes to be regraded to 2H:1V or flatter ■ All disturbed areas are to be scarified. ■ Stockpiled vegetation is to be spread of the borrow footprint. 	A	SRK
4	Revegetation	<ul style="list-style-type: none"> ■ Reclamation Plan to be completed by Teck. 	P	SRK

Notes:

- ¹ Technical Criteria (C): an established norm or requirement.
- ² Objectives (O): a specific result to be achieved based on verifiable evidence or facts.
- ³ Parameters (P): a defining characteristic.
- ⁴ Assumptions (A): considered adequate with the appropriate level of accuracy; should be confirmed during the engineering process.

5 Construction Monitoring and Surveillance

A construction monitoring and surveillance plan will be developed prior to construction that covers the construction and post-construction periods. At a minimum, the following construction monitoring activities are anticipated:

- Daily instrumentation readings of the North Embankment piezometers during the construction of the North Embankment berm and beach,
- Daily dam inspections monitoring for signs of deformation and seepage.
- Continuous monitoring of equipment trafficability conditions on the tailings cover to identify signs of deformation and potential instability.

6 Closure

This memorandum, “North Embankment Upgrades - Design Basis”, was prepared by



Ignacio Cueto
Senior Consultant



Peter Mikes, P.Eng.
Principal Consultant

SRK Consulting (Canada) Inc. has prepared this document for Teck Resources Ltd., our client. Any use or decisions by which a third party makes of this document are the responsibility of such third parties. In no circumstance does SRK accept any consequential liability arising from commercial decisions or actions resulting from the use of this report by a third party.

The opinions expressed in this document have been based on the information available to SRK at the time of preparation. SRK has exercised all due care in reviewing information supplied by others for use on this project. While SRK has compared key supplied data with expected values, the accuracy of the results and conclusions from the review are entirely reliant on the accuracy and completeness of the supplied data. SRK does not accept responsibility for any errors or omissions in the supplied information, except to the extent that SRK was hired to verify the data.

References

- Alberta Transportation (2004). Guidelines on Extreme Flood Analysis.
- [CDA] Canadian Dam Association. 2013. Dam Safety Guidelines
- [CDA] Canadian Dam Association. 2019. Technical Bulletin: Application of Dam Safety Guidelines to Mining Dams.
- [GISTM] Global Industry Standard on Tailings Management, 2020. August.
- [ICMM] International Council on Mining and Metals, 2021. Tailings Management – Good Practice Guide”. May.
- [MAC] Mining Association of Canada, 2021. Developing an Operation, Maintenance and Surveillance Manual for Tailings and Water Management Facilities.
- SRK Consulting (Canada) Inc. 2023a. Tailings Management Area Design Basis. Prepared for Teck Resources Ltd.: Kimberley, BC. Project number: CAPR001928. Issued September.
- SRK Consulting (Canada) Inc. 2023b. North Dam Repair As-built Report. Prepared for Teck Resources Ltd.: Kimberley, BC. Project number: CAPR001928. Issued May.
- SRK Consulting (Canada) Inc. 2023c. Sa Dena Hes Hydrometeorological Characterization Report. Prepared for Teck Resources Ltd.: Kimberley, BC. Project number: CAPR000463. Issued May.
- SRK Consulting (Canada) Inc. 2023d. North Embankment Potential Failure Mode Review. DRAFT. Prepared for Teck Resources Ltd.: Kimberley, BC. Project number: 1CT008.075. Issued January. 2023.
- Teck Resources Ltd., 2015. Detailed Decommissioning and Reclamation Plan, August 2015 Update. August 31.
- Teck Resources Ltd, 2019. Guideline for Tailings and Water Retaining Structures, January 2019.
- Yukon Energy Mines and Resources, 2013. Plan Requirement Guidance for Quartz Mining Projects, August 2013.

APPENDIX B
DESIGN DRAWINGS



Sa Dena Hes North Embankment Upgrades

Drawing Index				
Drawing Number	Drawing Title	Issued	Date	Revision
01	Construction Specifications	Issued for Tender	February 19, 2025	C
02	General Arrangement	Issued for Tender	February 19, 2025	C
03	Existing Site Conditions - North Embankment	Issued for Tender	February 19, 2025	C
04	North Embankment Upgraded Conditions Plan View	Issued for Tender	February 19, 2025	C
05	Upgraded Embankment Sections	Issued for Tender	February 19, 2025	C
06	Tailings Cover Drainage Updates	Issued for Tender	February 19, 2025	C
07	Water Conveyance Channel Details	Issued for Tender	February 19, 2025	C
08	Typical Erosion Control Blanket Details	Issued for Tender	February 19, 2025	C
09	Camp Creek Temporary Crossing	Issued for Tender	February 19, 2025	C
10	Reclaim Stockpile Borrow Area	Issued for Tender	February 19, 2025	C

PERMIT TO PRACTICE
Signature *Peter H. Mikes*
Date February 19, 2025
PERMIT NUMBER: PP019
Association of Professional Engineers
of Yukon



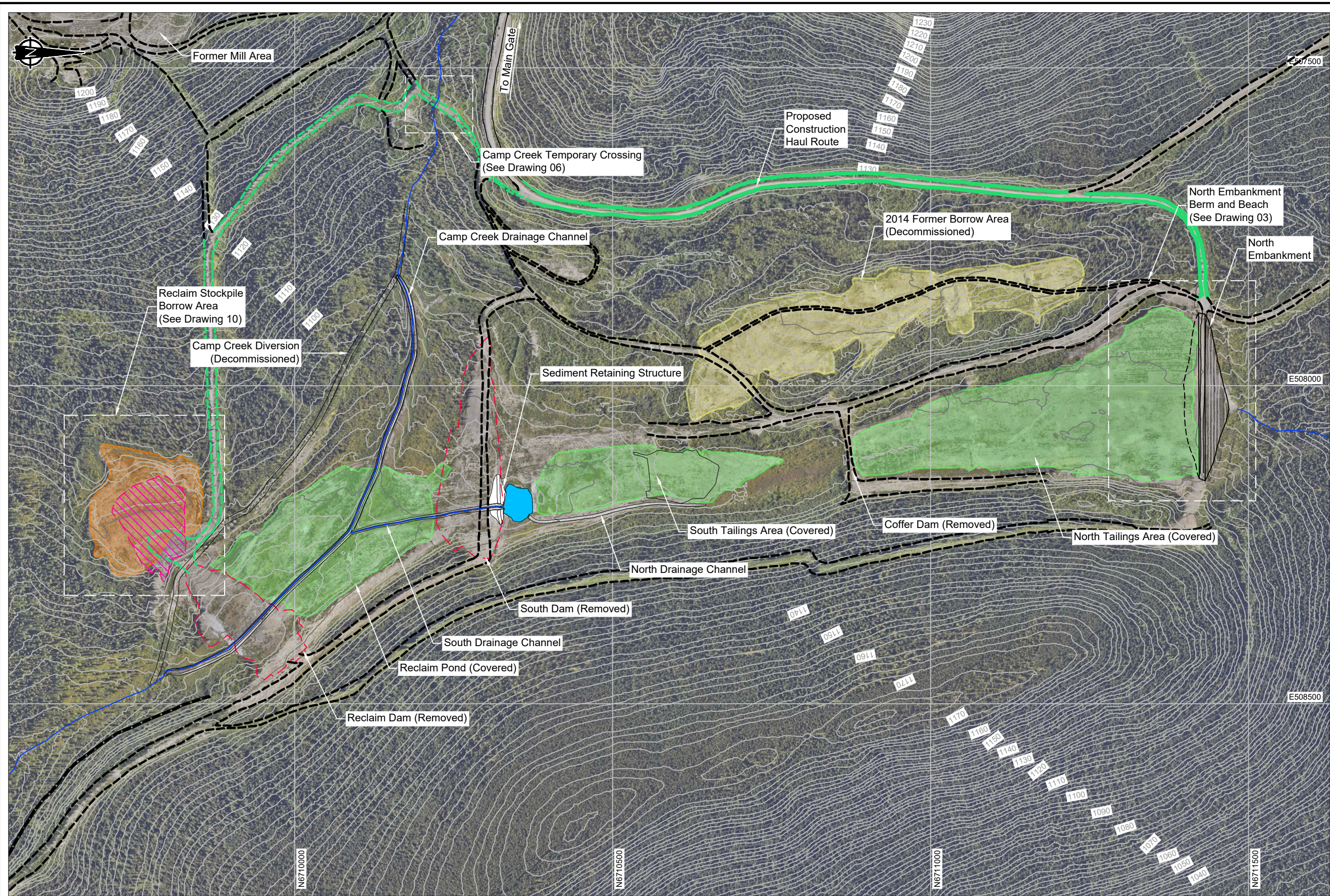

- LEGEND**
- Creek
 - Existing Road
 - Decommissioned Road
 - Proposed Construction Haul Route
 - Former Dam Footprint
 - 2014 Till Cover Footprint
 - 2014 Borrow Area (Seeded)
 - Reclaim Stockpile Borrow Area
 - Proposed Borrow Area Extent
 - SRS Sedimentation Pond

- NOTES**
1. All units are in meters unless otherwise specified.
 2. Contours are shown at 2.0 m intervals.
 3. Fill required for the the North Embankment Berm, Beach and Tailings Cover to be sourced from the Reclaim Borrow Stockpile.
 4. The Contractor is responsible for upgrading all haul roads to meet Yukon Workplace Health and Safety Regulation requirements.
 5. Coarse rock and riprap materials required for the project are to be sourced from the rock quarry located at KM17 of the access road to the site (not shown in this drawing) or an alternate source as directed by the Engineer.

- REFERENCES**
1. UTM NAD83 CSRS Zone 9V.
 2. Topography provided in 2022. File Name: SDH_2022_DEM.tif
 3. Extent of the 2014 till cover and Reclaim Borrow Stockpile obtained from the Amec Foster Wheeler 2014 As-built Report.

NOT FOR
CONSTRUCTION

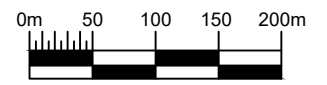

C:\Users\shay\SRK Consulting\F5261-Sa Dena Hes - 1040_CAD_GIS\CAD_C3D\CAPR002522_EOR_Services\North Dam Upgrade\CAPR002522 - GA.dwg

DRAWING NO.	DRAWING TITLE	NO.	DESCRIPTION	CHK'D	APP'D	DATE	NO.	DESCRIPTION	CHK'D	APP'D	DATE
REFERENCE DRAWINGS											
REVISIONS											
			C			Issued for Tender			KJH	PHM	25/02/19
			B			Issued for Permitting			IC	PHM	23/11/27
			A			Issued for Review			ONL	PHM	Oct23

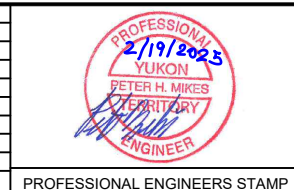

srk consulting

DESIGN: I. Cueto DRAWN: T. Haye REVIEWED: P. Mikes
 CHECKED: K. Howse APPROVED: P. Mikes DATE: February 19, 2025
 FILE NAME: CAPR002522 - GA.dwg

Teck

Sa Dena Hes

North Embankment Upgrades

General Arrangement

DRAWING NO. **02** REVISION NO. **C**

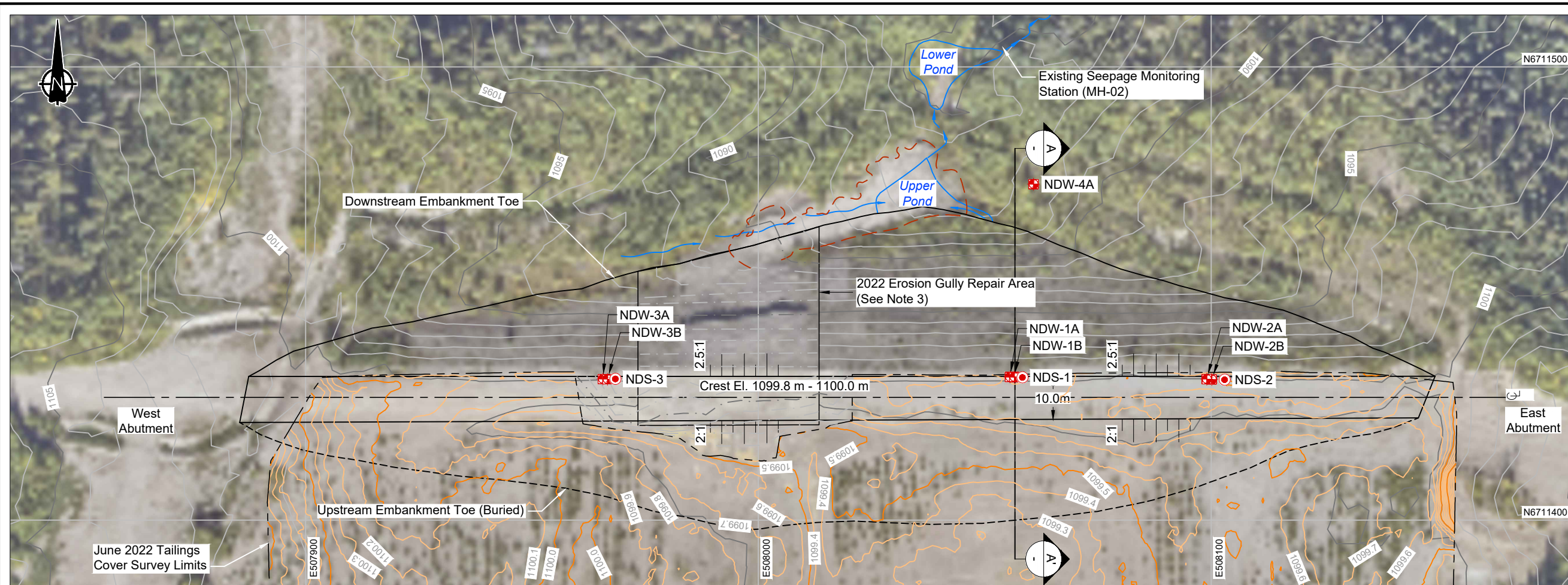

North Embankment Site Plan

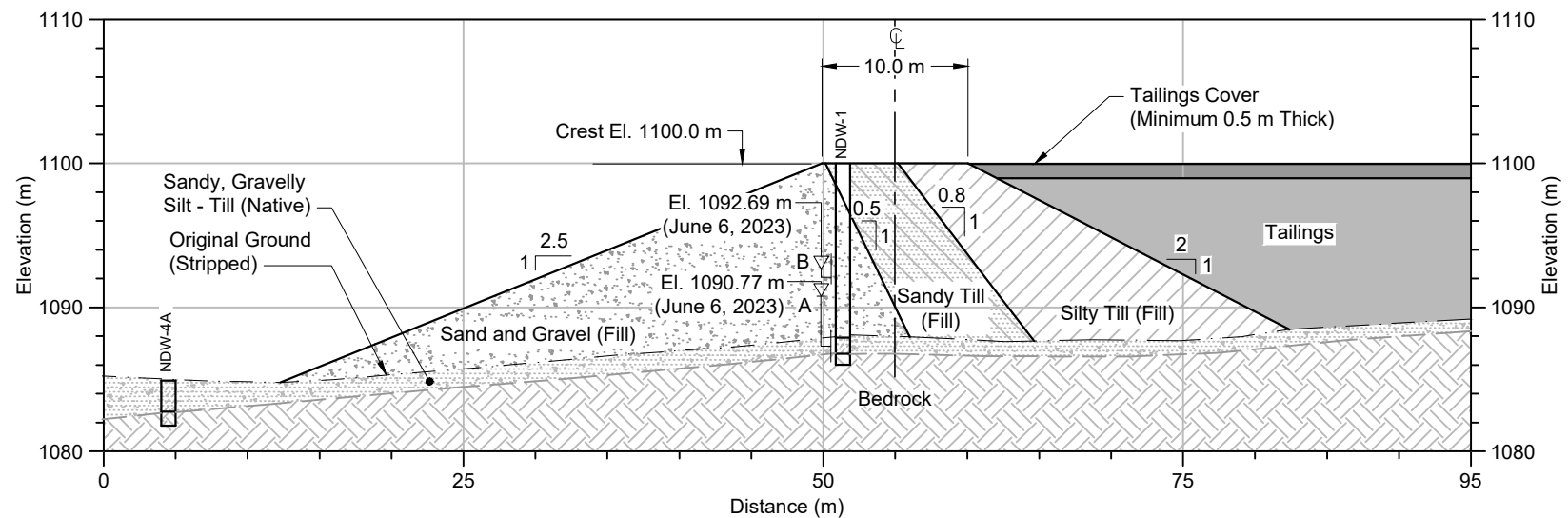
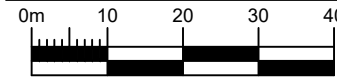

Cross Section A-A'

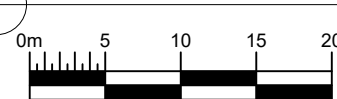

- LEGEND**
- Piezometer Head for Filter Zone Indicated
 - Piezometers Installed (Nov. 1991)
 - Settlement Gauge Installed (Nov. 1991)
 - Ground Contours
 - Tailings Cover Contours
 - Dam Footprint
 - 2022 Erosion Debris Extent
 - Existing Ground (Stripped)
 - Tailings Cover Survey Limits (UAV Drone Survey - June 2022)
 - Seepage

- NOTES**
1. All units are in meters unless otherwise specified.
 2. Ground contours are shown at 1.0 m intervals. Tailings cover contours are shown at 0.1 m intervals.
 3. Dashed contour lines in the 2022 erosion fully repair area are approximate as they are based on field surveys using a rod and level, and visual observations.

- REFERENCES**
1. Coordinates are UTM Zone 9, NAD83 (CSRS) and are derived holding values of point UGL100 fixed in 3D.
 2. June 2022 Tailings Cover Survey Coordinates of point UGL100 were established using Natural Resources Canada CSRS-PPP Service (precise point positioning). Elevations are orthometric and in meters. Elevations reference to the CGVD28 datum using the HTv2.0 Geoid Model. The digital file of this plan is UTM Grid scale, not ground scale. Combined scale factor at point UGL100 is CSF 0.9941220. Coordinates of UGL100 are:
 UGL100
 UTM N: 6709661.884m
 UTM E: 507376.593m
 Ortho Elev: 1206.100m
 UAV DEM and Imagery:
 Date: 2022-06-20
 UAV M300 with P1 Camera
 capture Altitude: 120m AGL
 GSD: 1.4cm/pix
 Orthophoto Resolution: 10cm/pix
 3. 2022 Site-wide LiDAR Survey provided in 2022. Filename: SDH_2022_DEM.tif.

NOT FOR CONSTRUCTION

C:\Users\shayw\SRK Consulting\F5261-Sa Dena Hes - 1040_CAD_GIS\CAD_C3D\CAD\PR002522_EOR_Services\North Dam Upgrade\CAPR002522 - ND_EC.dwg

REFERENCE DRAWINGS				REVISIONS								 Sa Dena Hes		North Embankment Upgrades	
												Existing Site Conditions - North Embankment			
										DESIGN: I. Cueto DRAWN: T. Haye REVIEWED: P. Mikes CHECKED: K. Howse APPROVED: P. Mikes DATE: February 19, 2025 FILE NAME: CAPR002522 - ND EC.dwg		SRK JOB NO.: CAPR002522			
										DRAWING NO. 03		REVISION NO. C			

Proposed Borehole Locations				
Borehole ID*	Northing	Easting	Elevation	Number of VWP's
BH-A	6711395.57	508036.70	1100.65	2
BH-B	6711448.40	508036.70	1094.70	2
BH-C	6711469.22	508036.70	1084.23	2
BH-D	6711393.32	508100.00	1100.58	2
BH-E	6711394.48	507965.73	1100.62	2

*Boreholes will be renamed at installation.

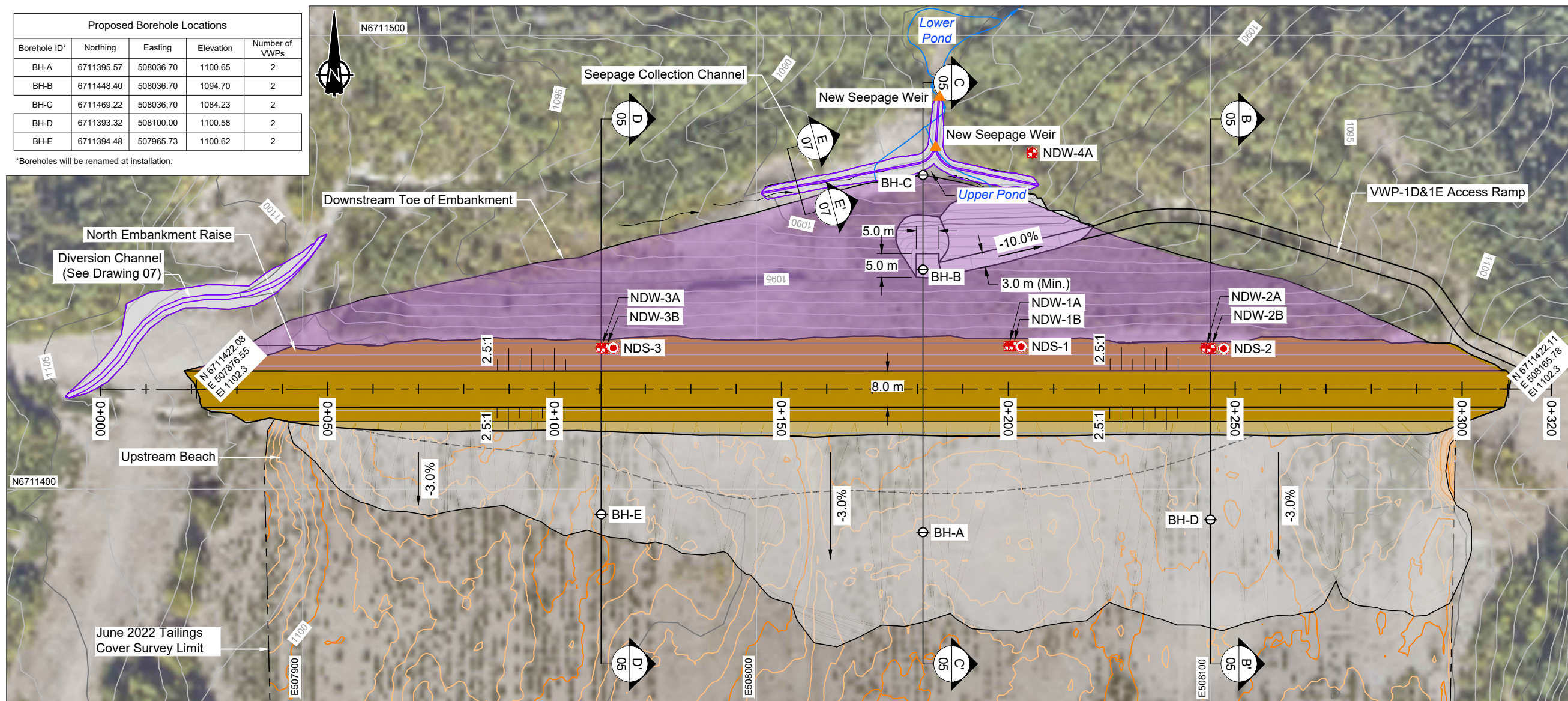

North Embankment Plan View

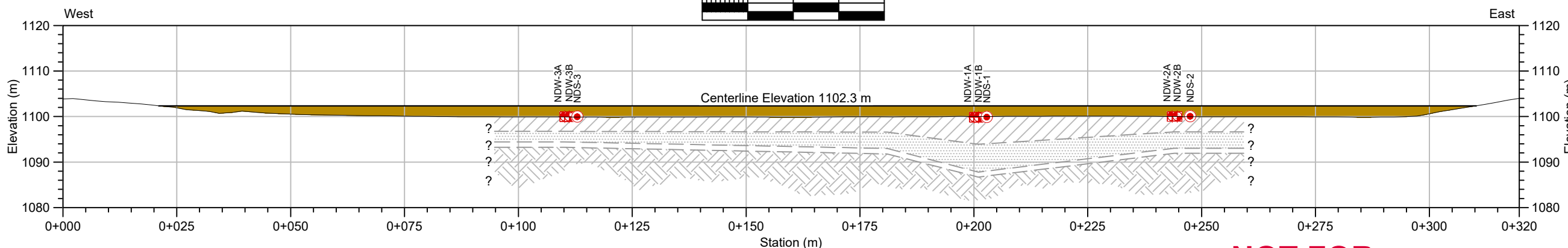

North Embankment Profile View

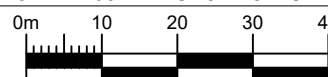

NOT FOR CONSTRUCTION

REFERENCES

1. UTM NAD83 CSRS Zone 9V. See Drawing 03.
2. Topography provided in 2022. File Name: SDH_2022_DEM.tif
3. Orthographic photo provided in September, 2022.

LEGEND

- ▲ Seepage Weir
- ⊕ Piezometers Installed (Nov. 1991)
- Settlement Gauge Installed (Nov. 1991)
- Proposed Borehole Location

- Ground Contours
- Tailings Cover Contours
- - - Tailings Cover Limits
- Seepage
- Watercourse
- ▭ Design Infrastructure
- ▭ Excavation

EXISTING MATERIALS

- ▨ Sandy Till (Fill)
- ▨ Gravelly Silty Sand (Till)
- ▨ Native Till
- ▨ Bedrock

PROPOSED MATERIALS

- ▨ Embankment Raise Till Fill
- ▨ Embankment Armouring Layer
- ▨ Upstream Beach

NOTES

1. All units are in meters unless otherwise specified.
2. Ground contours are shown at 1.0 m intervals. Tailings cover contours are shown at 0.1 m intervals.
3. Foundation Preparation:
 - a. Upstream Beach: All trees / shrubs are to be stripped and stockpiled at locations outside of the project footprint as directed by Teck.
 - b. Embankment Raise Footprint: All organic materials and the top 150mm of existing embankment fill is to be removed from the embankment raise footprint and the underlying surface compacted to 95% of the Modified Proctor maximum dry density.
 - c. Embankment Slope: All trees / shrubs are to be removed by cutting at ground surface. The removed vegetation is to be disposed of as directed by Teck.
4. Fill Placement and material specifications are summarized on Drawing 1 (Construction Specifications).
5. Vibrating Wire Piezometer installation to be completed by others.
6. The Contractor must take extreme caution during construction not to damage the existing dam instrumentation.
7. The road from the east abutment to the BH-B Access Ramp may be field fit.
8. The seepage weir locations and channel alignments will be field fit under the direction of the Engineer.

C:\Users\shayw\SRK Consulting\F5261 - Sa Dena Hes - 1040_CAD_GIS\CAD_C3D\CAPR002522_EOR_Services\North Dam Upgrade\CAPR002522 - ND_FC.dwg

DRAWING NO.	DRAWING TITLE	NO.	DESCRIPTION	CHK'D	APP'D	DATE	NO.	DESCRIPTION	CHK'D	APP'D	DATE

PROFESSIONAL ENGINEERS STAMP

PETER H. MIKES
REGISTERED PROFESSIONAL ENGINEER
YUKON TERRITORY
2/19/2025

srk consulting

DESIGN: I. Cueto DRAWN: T. Haye REVIEWED: P. Mikes
CHECKED: K. Howse APPROVED: P. Mikes DATE: February 19, 2025
FILE NAME: CAPR002522 - ND FC.dwg

Teck

Sa Dena Hes

SRK JOB NO.: CAPR002522

North Embankment Upgrades

North Embankment Upgraded Conditions Plan View

DRAWING NO. 04 REVISION NO. C

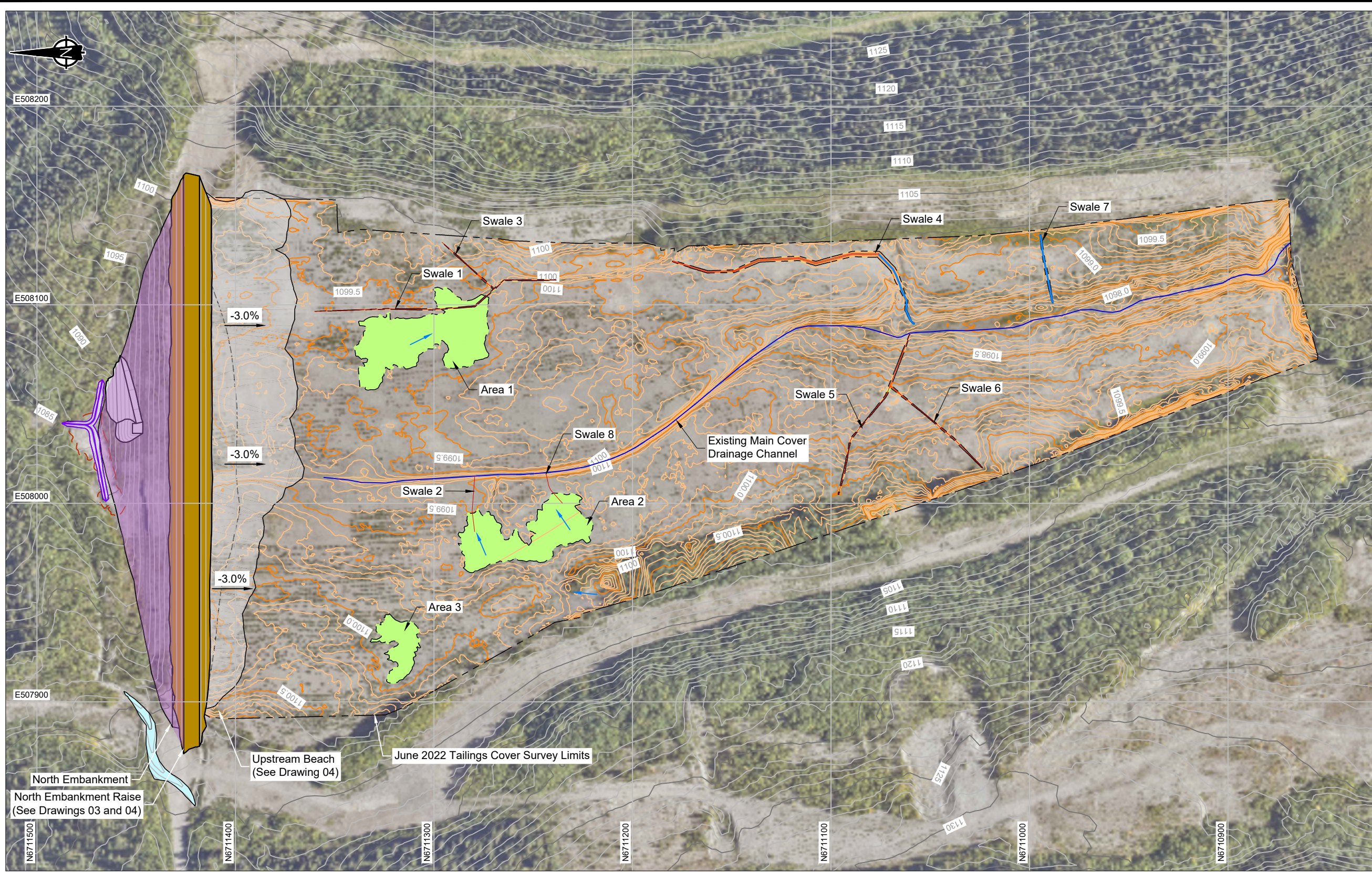

- LEGEND**
- Drainage Direction
 - Ground Contours
 - Tailings Cover Contours
 - Tailings Cover Limits
 - Erosion Debris Extent
 - Decommissioned Road
 - Swale Centerline (unlined)
 - Swale Centerline (Lined with Erosion Control Blanket)
 - Design Infrastructure
 - Embankment Raise Till Fill
 - Upstream Beach
 - Excavation
 - Fill Area
- NOTES**
1. All units are in meters unless otherwise specified.
 2. Ground contours are shown at 1.0 m intervals. Tailings cover contours are shown at 0.1 m intervals.
 3. Cover fill is to be sourced from the Reclaim Borrow Stockpile.
 4. The swale grades may be adjusted to suit field conditions, but shall not be less than 0.2% in all cases unless approved by the Engineer. Refer to Drawing 07 for typical swale cross sections.
 5. The Erosion Control Blankets are to be installed in Swales 4 and 7 as per manufacturers instructions and meet the product specifications provided in the Technical Specifications.
 6. Guidelines for the Erosion Control Blanket are provided in Drawing 08.
 7. Prior to any fill placement, a trafficability assessment is to be completed under the direction of the Site Engineer to ensure that the equipment is appropriate for the fill placement. Details of the trafficability procedures are provided in the Technical Specifications.
 8. The Contractor is to provide a spotter during the fill placement who will be trained to monitor for signs of excessive deformation by the Site Engineer as described in the Technical Specifications.
 9. All signs of ground deformation is to be brought to the attention of the Site Engineer immediately with all work on the cover stopped until approve to resume is provided by the Site Engineer.
 10. All areas of fill placement and swale construction are to be hydroseeded following completion of the earthworks.

- REFERENCES**
1. UTM NAD83 CSRS Zone 9V.
 2. Topography provided in 2022. Refer to Drawing 03.
 3. Orthographic photo provided in September, 2022.

NOT FOR
CONSTRUCTION

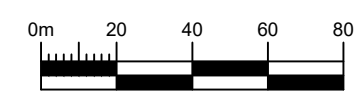

C:\Users\shay@SRK Consulting\F5261 - Sa Dena Hes - 1040_CAD_GIS\CAD_C3D\CAPR001928 - North Embankment Cover.dwg

DRAWING NO.	DRAWING TITLE	NO.	DESCRIPTION	CHK'D	APP'D	DATE	NO.	DESCRIPTION	CHK'D	APP'D	DATE
REFERENCE DRAWINGS											
REVISIONS											
			C Issued for Tender			25/02/19			KJH	PHM	
			B Issued for Permitting			23/11/27			IC	PHM	
			A Issued for Review			Oct23			ONL	PHM	



srk consulting

DESIGN: I. Cueto DRAWN: T. Haye REVIEWED: P. Mikes
 CHECKED: K. Howse APPROVED: P. Mikes DATE: February 19, 2025
 FILE NAME: CAPR001928 - North Embankment Cover.dwg

Teck

Sa Dena Hes

SRK JOB NO.: CAPR002522

North Embankment Upgrades	
Tailings Cover Drainage Updates	
DRAWING NO. 06	REVISION NO. C

- LEGEND**
- Anchor Trench Excavation
 - Erosion Control Blanket Edge
 - Erosion Control Blanket Underlying Edge

- NOTES**
1. All units are in meters unless otherwise specified.
 2. The erosion control blanket is to be installed as per manufacturers instructions and meet the product specifications provided in the Technical Specifications.
 3. The anchor details provided in the drawing are guidelines and field-fits will be required to suit field conditions under the direction of the site Engineer.

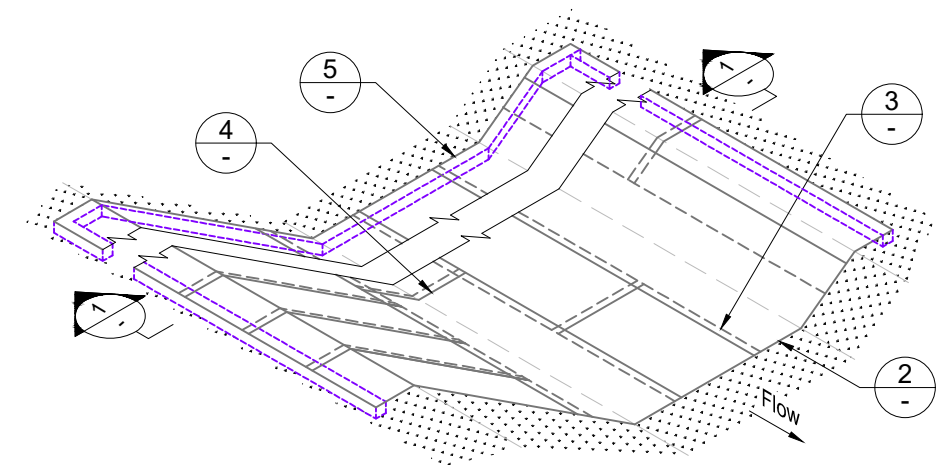
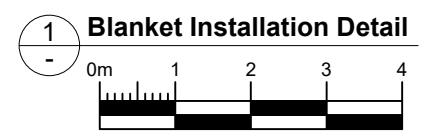
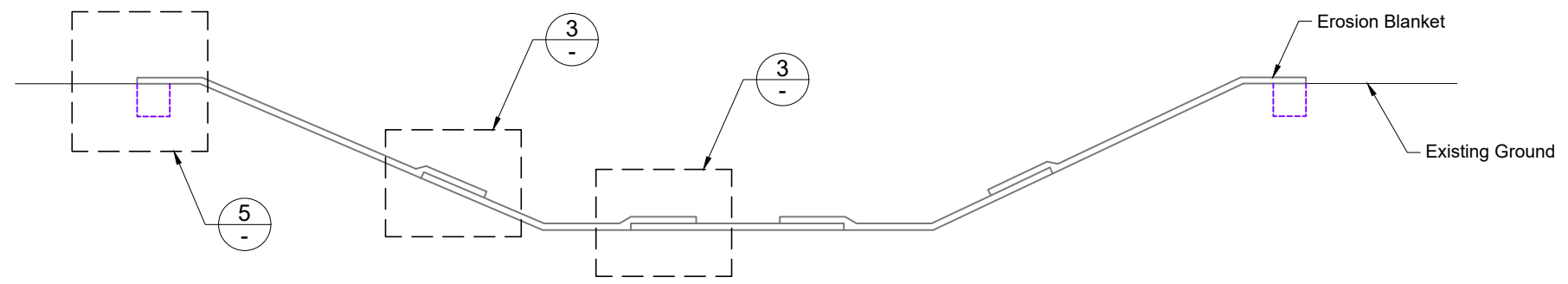

Channel Perspective View
Not To Scale

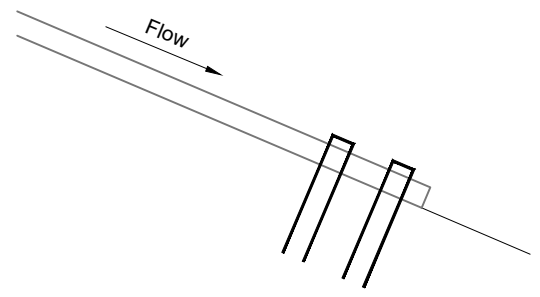

2 Termination Detail
Not To Scale

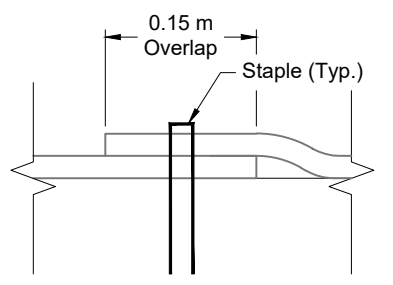

3 Side Seam Overlap Staple Detail
Not To Scale

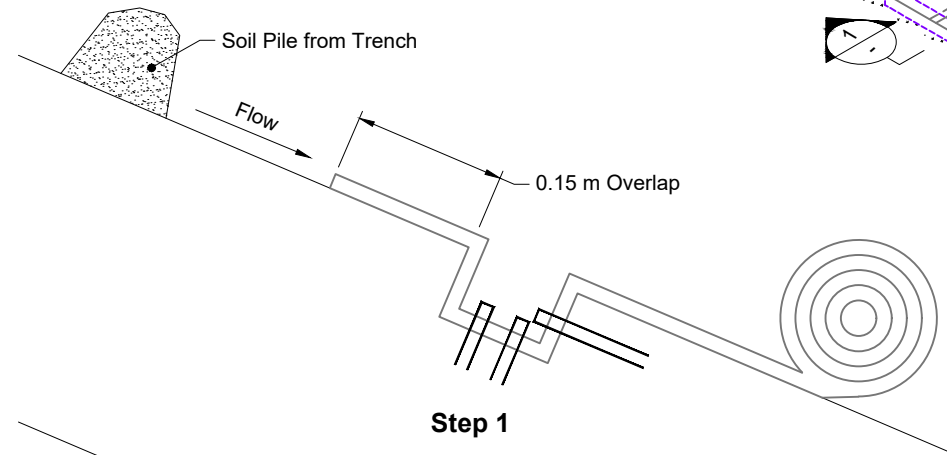

Step 1

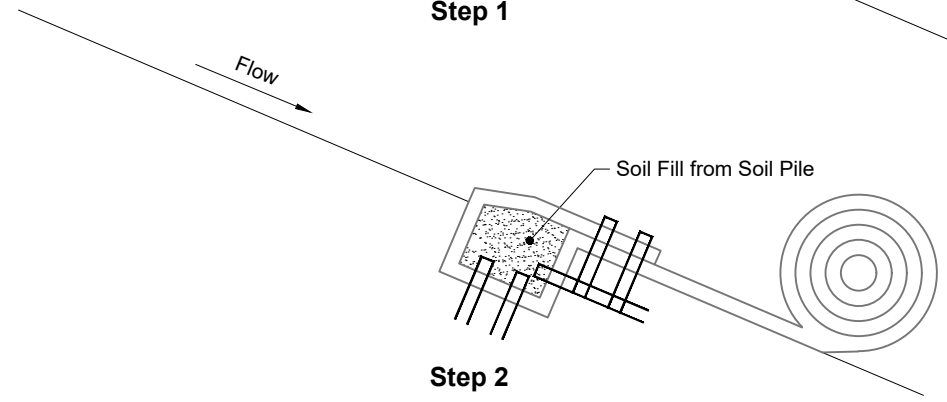

Step 2

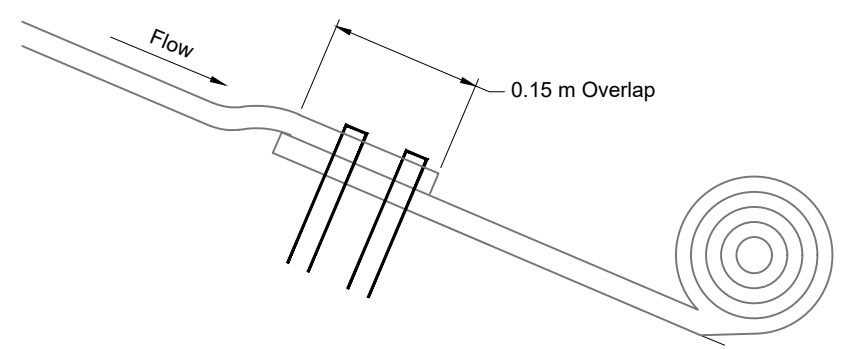

4 Channel Blanket End of Roll Overlap
Not To Scale

5 Anchor Trench Detail
Not To Scale

NOT FOR CONSTRUCTION

C:\Users\shay\SRK Consulting\F5261 - Sa Dena Hes - 1040_CAD_GIS\CAD_C3D\CAPR002522_EOR_Services\North Dam Upgrade\CAPR001928 - North Embankment Cover.dwg

DRAWING NO.	DRAWING TITLE	NO.	DESCRIPTION	CHK'D	APP'D	DATE	NO.	DESCRIPTION	CHK'D	APP'D	DATE
REFERENCE DRAWINGS											
REVISIONS											
							C	Issued for Tender	KJH	PHM	25/02/19
							B	Issued for Permitting	IC	PHM	23/11/27
							A	Issued for Review	ONL	PHM	Oct23



srk consulting

DESIGN: I. Cueto DRAWN: T. Haye REVIEWED: P. Mikes
 CHECKED: K. Howse APPROVED: P. Mikes DATE: February 19, 2025

FILE NAME: CAPR001928 - North Embankment Cover.dwg

Teck

Sa Dena Hes

SRK JOB NO.: CAPR002522

North Embankment Upgrades	
Typical Erosion Control Blanket Details	
DRAWING NO. 08	REVISION NO. C

APPENDIX C
ENVIRONMENTAL INSPECTION CHECKLIST

Water Quality					
Work Around Water?		Y	N		
Are erosion protection measures in place and in good working order?		Y	N		
Observable erosion?		Y	N		
Is chemical and fuel storage >30m from water?		Y	N		
Camp Creek Crossing Field Measurements					
Above Crossing					
Water Temp (°C)	Conductivity (µS/cm)	pH	Turbidity (NTU)	Lab Sample Collected?	Y/N
				If yes, collect second sample below crossing.	
Below Crossing					
Water Temp (°C)	Conductivity (µS/cm)	pH	Turbidity (NTU)	Lab Sample Collected?	Y/N
Water Withdrawal					
Volume of water withdrawn		_____ m ³ /d			
Fish screens present and in good working order (i.e., no openings greater than 2.54 mm, clean of debris)		Y	N		
Fish observed		Y	N		
Soil Management and Erosion Control					
Vehicles and equipment remain on designated roadways to reduce impacts to vegetation and soil compaction unless necessary?		Y	N		
Equipment operation in a manner that prevents soil compaction?		Y	N		
Erosion controls are in place where required to prevent sediment erosion into waterbodies and in good working order?		Y	N		
No materials are stockpiled within 15 m of the top of bank of any watercourse?		Y	N		
Wildlife					

Food waste, garbage and chemical storage managed to avoid wildlife attraction?	Y	N	
If sensitive wildlife habitat features (including nests) have been identified on site, are measures to prevent habitat disturbance in working order?	Y	N	NA
Wildlife observations on site? If yes, complete a wildlife observation form.	Y	N	
Bird and Nest Protection			
Work between April 30 and August 20 If working in a new area, was a nest sweep completed in the previous 48 hours?	Y	N	
Set back required (provide comments on birds identified, setback distance and direction provided by QP)?	Y	N	
QP written report within 24 hours?	Y	N	
Any equipment standing for >24 hours must be inspected for bird nests. Inspections required (provide comments if nests/nesting activity was observed and mitigations applied)?	Y	N	
Hydrocarbon/Spill Prevention and Control			
Fuel storage and equipment service/refueling greater than 30 m from any waterbody?	Y	N	
Spill response kits in vehicles/equipment and available close to areas where hydrocarbon or chemical products are in use?	Y	N	
Spill trays used for equipment stationery for more than 8 hours?	Y	N	
Other (include observations or incidents that occurred today):			

Photographs

APPENDIX D
CULTURAL HERITAGE RESOURCE CHANCE FIND PROCEDURE

Document ID: TLP-EP-002	Date of Last Revision: February 21, 2024
Review Cycle: Every 3 years	Document Owner: Michelle Unger, Manager Environmental Performance

PURPOSE When ground altering activities occur at Legacy Properties, there is the potential for the identification of heritage objects that are important because of their historical, cultural, scientific or educational value. This procedure outlines the steps to take if Cultural Heritage Resources or Human Remains are identified (or potential) and how to avoid or reduce adverse effects.

OBJECTIVE To protect and manage sites with Cultural Heritage Resources that may become exposed during ground disturbance activities (e.g., drilling, fencing, remediation or reclamation).

APPLIES TO All Teck employees, contractors, and subcontractors performing work tasks on Teck Legacy Properties.

DEFINITIONS

Archaeological Artifact – Any object which has been modified, fashioned, or manufactured by humans. Artifacts can include but are not limited to tools, weapons, ornaments, utensils, sculptures. Examples, including pictures, are provided in Appendix A.

Cultural Heritage Resources – Paleontological resources, archaeological artifacts and historic structures, cultural sites (trails, historic settlements, log cabins), spiritual sites, culturally modified trees (CMTs), other human-made structures, features or objects and could be more than 45 years old.

Historic structures – Cabins, caches and grave sites

Paleontological Resource – protected as a Cultural Heritage Resource and is defined as a work of nature consisting of or containing evidence of multicellular beings and includes fossilized remains of animals (bones, teeth, scales, shells) and plants, as well as fossilized footprints or tracks, and eggshells. Examples, including pictures, are provided in Appendix B.

All copies of this document are uncontrolled when printed.

TRAINING

All Teck employees must complete the EHSC Initial Event Response Procedure training which describes basic requirements for initial response and reporting should an event occur. This training is assigned in TLP training management system Sitrine.

All Teck employees that conduct or supervise field work will be provided a copy of the Cultural Heritage Resource Protection Management Plan (in development) and Procedure for annual review in Sitrine.

DISCOVERY OF CULTURAL HERITAGE RESOURCE PROCEDURE

1. If you know or suspect you have discovered a Cultural Heritage Resource object, stop any work in the area immediately. **Cultural Heritage Resource objects must not be moved or disturbed!**
 - Record GPS coordinates of the location and/or drop a location pin using a phone app.
 - Take a picture of the artifact or suspected resource (include an object of familiar size to provide scale).
 - Estimate the size of the object, description of the setting and access.
 2. Isolate and protect the area (e.g., use flagging, rope or above-ground fencing to secure the area) leaving a buffer of at least 30 m around the potential site.
 3. Report immediately to Teck Legacy Dispatch at 1-250-427-6079, toll free at 1-855-899-6857 and complete an [Initial Event Report Form \(TLP-SF-004\)](#) and collect relevant information and images of the find/location as per the Cultural Heritage Resource Management Documentation form attached.
 4. The Dispatcher will complete the following:
 - Confirm that the site is not to be disturbed and is protected as outlined above in Step 1 and 2.
 - Will notify the Manager, Environmental Performance (or designate)
 5. The Manager, Environmental Performance (or designate) will ensure the following:
 - Follow up with the reporter and document all details as per the Cultural Heritage Resource Management Documentation form attached.
 - Notify the Site Manager, and Manager, Social Performance and Community Partnerships of the initial finding.
-

All copies of this document are uncontrolled when printed.

-
- Engage with a professional Archaeologist to review available descriptions and images and conduct a site visit if necessary to develop a management plan. This will also be done in coordination with local Indigenous Peoples (see Step 6 below).
 - Report details of the discovery to the appropriate provincial and/or territorial agencies as listed in Table 1.
6. The Manager, Social Performance and Community Partnerships (or designate) will ensure a communication plan is developed and the local Indigenous Peoples are contacted as soon as possible.
 7. Work will not proceed, until the professional Archaeologist advises that there are no concerns or a management plan has been developed and implemented.
-

**DISCOVERY
OF HUMAN
REMAINS
PROCEDURE**

1. If suspected human remains are encountered, **stop work** in the area immediately.
 2. **Report to Teck Legacy Dispatch immediately** at 1-250-427-6079, toll free at 1-855-899-6857. Complete an initial event report form.
 - **Do not disturb** any remains that you might encounter.
 - Isolate and protect the area (e.g., use flagging, rope or above-ground fencing to secure the area) leaving a buffer of at least 30 m around the potential site.
 - Be prepared to give a description and/or location of the suspected human remains.
 3. Dispatch will notify the Site Manager who shall report to RCMP or local police. If the Site Manager is unavailable, then Dispatch may be required to RCMP directly.
 4. Next step instructions to be provided by the RCMP.
 5. Site Manager to notify Director, Legacy Properties, VP Environment and internal legal council.
-



REMINDER

- ***Do not disturb any found Cultural Heritage Resources or Human Remains, including suspected archaeological artifacts, fossils, or bones. Work must be stopped if a find is identified***

All copies of this document are uncontrolled when printed.

Table 1 – Regulatory Contact Information

Location	Agency	Contact Information
British Columbia	Archaeology Branch BC Fossil Management Office	(250) 953-3334 (250) 356-1432
Yukon	Yukon Archaeology Program Yukon Palaeontology Program	(867) 667-5983 (867) 667-8089
Northwest Territories	Prince of Wales Northern Heritage Centre Land use permit states to notify the Board or an Inspector	(867) 767-9347 ext. 71250 or 71251 MVLWB - 867-669-0506 Inspector at 867-872-2555 (ext 24)
Ontario	Ontario Archaeological Society	(416) 406-5959
Quebec	Provincial Archaeology Office	(514) 872-7720
Newfoundland	Provincial Archaeology Office	(709) 729-2462

All copies of this document are uncontrolled when printed.

CULTURAL HERITAGE RESOURCE MANAGEMENT DOCUMENTATION

DATE:

TIME:

TIME WORKED STOPPED (If required):

RECORDER'S NAME:

DEPARTMENT/COMPANY:

POSITION:

LEGACY SITE:

LOCATION DESCRIPTION:

UTM:

SURVEYED (YES/NO):

DEPTH BELOW SURFACE:

MARKED and PROTECTED -

DESCRIPTION OF FIND:

SKETCH (attach separately if required):

All copies of this document are uncontrolled when printed.





PHOTOGRAPHS ATTACHED: YES/NO SITE MAP ATTACHED: YES/NO METHOD USED TO MARK AND PROTECT:
NAME AND SIGNATURE OF SUPERVISOR(S)/MANAGER(S):
FOLLOW-UP (FURTHER ACTION IF REQUIRED): Attach a separate sheet if necessary.
COMMUNICATION DOCUMENTATION: Who was contacted (e.g., Site/Project Manager, Archaeology Branch, museum)? Record the name, date, time, phone number and details of conversation. Attach a separate sheet if necessary.

***PLEASE ATTACH ANY ADDITIONAL DOCUMENTATION





APPENDIX A
EXAMPLES OF ARCHEOLOGICAL FINDS

All copies of this document are uncontrolled when printed.





A.1 EXAMPLES OF ARCHAEOLOGICAL FINDS

Types of Artifact or Feature	Photo	How to Visually Identify Artifact
Obsidian		<p>Volcanic glass rock, usually black.</p> <p>Very shiny, smooth, and having sharp edges.</p>
Flint Chert Agate		<p>Very fine-grained rocks which often have a semi-glassy finish and are usually white, pinkish, brown, grey or blue-grey.</p> <p>Varieties of chert often occur in chalk and limestone formations and include flint and agate.</p> <p>Flint often occurs in oval to irregular nodules and is a popular rock used to sharpen blades and other surfaces.</p>
Slate		<p>Often occurs as a black, green or grey.</p> <p>Breaks in horizontal layers.</p>
Antler Bones		<p>Often resembling bone, it is very difficult to differentiate antlers from bone without a microscope.</p> <p>Bones have tiny canals that run through them to carry nutrients and house nerves and other organic material.</p> <p>Often organic material adheres to the walls of these canals and turns dark as it decays.</p>

All copies of this document are uncontrolled when printed.

<p>Pottery</p>		<p>Pottery is often found in small pieces or shards which were part of a larger object like a bowl, pot, and cup.</p> <p>Typically, is found in earth-tone colours (commonly red, brown, black and orange). Often contains paint pigment or decorative inscriptions.</p>
<p>Metal</p>		<p>Often found rusted and corroded, metal can range significantly in size, shape, and colour.</p>
<p>Pecked stone hand mauls (hammers)</p>		<p>Mauls were fashioned from materials such as stone, bone, antlers, and shells. These tools were used for pounding and hammering during activities such as woodworking and food preparation.</p>
<p>Cache pit</p>		<p>Used to store foods for periods of time. Characterized by small depressions generally not more than 3m by 2m wide by 2m deep found in well-drained areas.</p>
<p>Rock cairns</p>		<p>Characterized by the structured placement of rocks in piles.</p> <p>Used for marking or defining a trail/route, however they may also be used to mark boundaries or graves.</p>

All copies of this document are uncontrolled when printed.





<p>Chipped stone flakes</p>		<p>Stone objects or pieces of stone that have been chipped and/or ground in a non-natural way (most common finds).</p>
<p>Burial site indicators</p>		<p>Materials that may indicate that a burial site is present include the presence of any one of the following:</p> <ol style="list-style-type: none"> 1. human remains (i.e., bones); 2. rectangular depressions; and stone cairns.
<p>Buried fire pit Fire-cracked rock</p>	 	<p>Buried fire pits are easily recognizable due to burnt areas on the ground or vegetation close by. Often constructed out of rocks and contains traces of ash.</p> <p>Fire-cracked rock is stone that has been fractured as a result of rapid or alternate heating and cooling in campfires, or most particularly when using fire-heated rock to boil water in features known as boiling pits. Fire cracked rock is typically associated with resource processing and/or food preparation.</p>

All copies of this document are uncontrolled when printed.

APPENDIX B
EXAMPLES OF FOSSIL FINDS

All copies of this document are uncontrolled when printed.

B.1 EXAMPLES OF FOSSIL FINDS

Types of Artifact or Feature	Photo	How to Visually Identify Artifact
Ammonite		<p>These fossils are an extinct group of marine invertebrate animals.</p> <p>Ammonites are excellent index fossils, and it is possible to link the rock layer in which they are found to specific geological time periods. Their fossil shells usually take the form of planispirals, although there were some helically-spiraled and non-spiraled forms (known as heteromorphs).</p>
Trace fossil		<p>Trace fossils may be impressions made on the substrate by an organism. For example, burrows, borings (bioerosion), urolites (erosion caused by evacuation of liquid wastes), footprints and feeding marks, and root cavities. These fossils are geological records of biological activity.</p>
Plant fossil		<p>A plant fossil is any preserved part of a plant that has long since died. Most common are adpressions (compression-impressions) which are flattened plants parts (leaves).</p>
Trilobite		<p>These fossils are a well-known fossil group of extinct marine arthropods that form the class Trilobita.</p> <p>Trilobites are hard-shelled, segmented creatures that lived hundreds of millions of years ago in the earth's ancient seas.</p>

All copies of this document are uncontrolled when printed.

APPENDIX E
SPILL CONTINGENCY PLAN

Sä Dena Hes Mine

Spill Contingency Plan

February 23, 2024

Legacy
Properties

/ **Teck**

Table of Contents

1.0	Purpose and Objectives	1
2.0	Site Description	1
3.0	General Spill Contingency Plan	2
3.1	Release Prevention	2
3.2	Reportable Spills	3
3.3	Discovery and Response to Spills	3
3.4	Spill Reporting Notification Procedure	5
3.5	Spill Incident Investigation	6
4.0	Training	6
Appendix A	Initial Event Report Form	
Appendix B	Yukon Spills Regulations - Schedule A	
Appendix C	Yukon Spills Regulations and Reporting Information	

List of Figures

Figure 2.1	Mine Location.....	2
------------	--------------------	---

1.0 PURPOSE AND OBJECTIVES

This document outlines contingency measures and response strategies for spills of potentially hazardous substances at the Sä Dena Hes mine, which may adversely affect the environment, and/or human health and safety. Rapid deployment of emergency personnel and equipment to a spill will both protect the health and safety of employees and public, as well as minimize potential effects to the environment.

All Teck Resources Limited (Teck) employees and Contractors working at the Sä Dena Hes Mine should be familiar with this document. New employees and contractors will be introduced to the plan as part of their orientation. Personnel will understand the potentially hazardous situations that spills can create to the health and safety of workers and the environment. They will understand their responsibilities as workers to prevent, identify, report, and appropriately deal with a spill. This document will be available for viewing by all workers. The company will advise workers of revisions or changes to the plan.

The objectives of the manual are to:

- identify potentially hazardous materials located on site.
- identify spill prevention measures.
- identify and describe spill response and emergency response measures in the case of an incident.
- establish a high order of preparedness in the event of a spill.
- ensure an orderly and timely decision-making, response, and reporting process.

2.0 SITE DESCRIPTION

The Sä Dena Hes property is the site of a former lead-zinc mine that operated from 1991 to 1992. The property is located 45 km north of Watson Lake in the Yukon Territory and is owned by the Sä Dena Hes Mining Corporation, which is a joint venture between Teck Resources Limited (Teck) and Pan-Pacific Metal Mining Corp., a wholly-owned subsidiary of Korea Zinc. Teck is the operator under the joint venture agreement for the site. Figure 2.1 provides a general location map of the Sä Dena Hes mine.

Permanent closure and decommissioning activities commenced in 2013 and were completed in 2015. Reclamation activities conducted at the site included applying a simple cover, using natural glacial till materials, to most mine disturbed areas limiting the release of contaminants to the air, water, and land. Surface contouring and vegetation have been completed for protection against water erosion. A revegetation program was implemented once the cover system was finished in 2015.

The site remains under a surface land lease for the purposes of ongoing environmental monitoring and maintenance of geotechnical structures (e.g., waste rock dumps and tailings impoundment). There are no chemicals / fuels stored on site. All site roads were decommissioned with the exception of the main access road. Access to the site is controlled via a locked gate on the main access road. Routine site inspections, maintenance and water sampling are the only site activities that are being carried out on site.

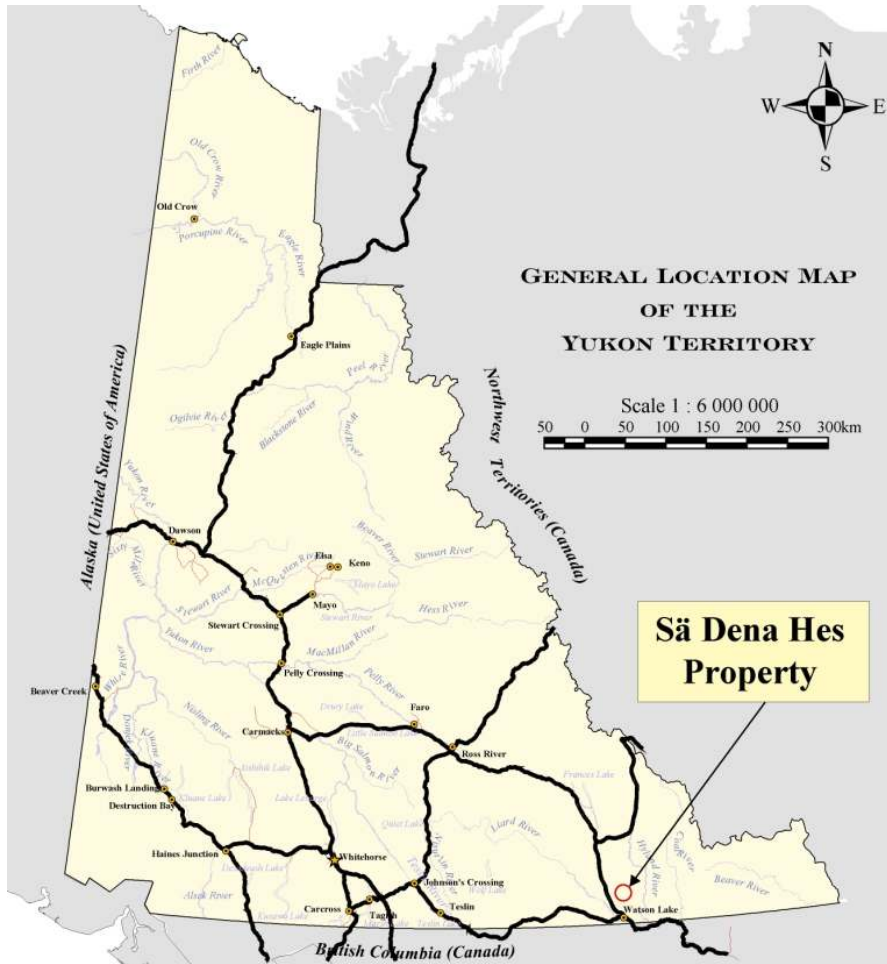

Figure 2.1 Mine Location

3.0 GENERAL SPILL CONTINGENCY PLAN

The mine remains permanently closed and there are no hazardous materials that are routinely stored on site. There are two types of spills that are possible at Sä Dena Hes under current operations as follows:

- A release from the tailings impoundment area
- Product spills during maintenance projects

3.1 Release Prevention

Releases from the tailings impoundment area are prevented by maintaining a routine and preventative maintenance and monitoring schedule according to the Sä Dena Hes Tailings Management Facility Operation, Maintenance and Surveillance Manual for the site (OMS – Document 00000028HZZ). The OMS states that at a minimum two site inspections will occur and that maintenance will be completed promptly following identification. The spring inspection is supplemented with remote monitoring. The annual snowmelt surveillance will include satellite monitoring to track the development of ponded water adjacent to the North Embankment, and a site inspection to determine if drainage mitigation is required.

All copies of this document are uncontrolled when printed.

Other instrumentation including piezometers, weir flows, and settlement gauges are also used as part of the ongoing monitoring of the facility.

Teck requires all employs and contractors to prevent the release of contamination to the surrounding environment and therefore, during applicable projects the following practices shall be used:

- Fuels and chemicals will be stored greater than 30 m from any watercourse
- All fuel and chemical storage, including waste bins, will have adequate secondary containment that is regularly inspected for damage, wear and tear, and replaced as required.
- Any fuel-powered equipment that is stationary for more than 24 hours must have drip trays or secondary containment (e.g., collapsible containment berm)
- Spill kits will be available whenever chemical use or fueling occurs
- Fueling practices must include spill containment, such as drip trays or other similar, to catch potential spills while fueling.
- Never leave fuel pumping unattended.

3.2 Reportable Spills

A spill is defined according to Part 11, Section 132 of the Yukon *Environment Act* as follows:

- a) into the natural environment
- b) from or out of a structure, vehicle, or other container; and
- c) that is abnormal in quantity or quality in light of all circumstances of the release; or
- d) in excess of an amount specified in the regulations

Section 3 of the Spill Regulations, states that a spill in excess of the amounts specified in Schedule A is a spill under the *Act*. Schedule A of the Spill Regulations is reproduced in Appendix B.

Spills that exceed volumes defined in Schedule A of the Spill Regulations and any that are otherwise deemed reportable as per the *Environment Act* will be reported to the Yukon Spill Report Centre under the direction of the Manager, Environmental Performance.

For purposes of Section 133 of the *Act*, a report to the Yukon Spill Report Centre will be considered a report to an environmental protection officer.

3.3 Discovery and Response to Spills

In the event of a breach of the embankment, barriers will be placed (e.g., rock or earthen berm) or constructed to prevent further migration of tailings and material as soon as it is safe to do so using available equipment on site and those procured from Watson Lake. Tailings and embankment material will be collected and returned to the tailings impoundment.

For spills involving products (e.g., chemicals or fuels), the following provides a general response to any product spill upon initial discovery. Also refer to the product Safety Data Sheet (SDS) for more specific information on material handling, hazards, and spill response.

FIRST PERSON TO OBSERVE THE SPILL

- Ensure personal and worker safety. If you cannot identify the spilled substance, consider it dangerous.

All copies of this document are uncontrolled when printed.

IF PERSONNEL ARE INJURED

- Call for medical help, attend to injured person, and administer first aid if safe to do so.

IF SAFE

- Stop all sources of ignition and stop or reduce the source flow of the spill.
- Shut off all valves.
- Shut off all electrical power.
- Initiate containment.
- Put down adsorbent pads and berm spill area if possible.
- Do not enter confined spaces.
- Do not expose self to fire hazard.
- Complete the spill report form and report the spill.

IF UNSAFE

- Initiate evacuation (upgrade or upwind) – move to safe area.
- Isolate area and deny entry until qualified response personnel arrive.
- Deny access to all unauthorized personnel.

REPORT

- For all spills of any size notify Legacy Dispatch 250-427-6079 immediately when safe to do so
- Complete the Initial Event Report and submit to legacy.safety@teck.com within 2 hours. The Initial Event Report form is included in in Appendix A.

SPILL REMEDIATION

- For spills to water, absorbent pads and berms shall be used to contain the spill and a vacuum truck shall be contacted immediately.
- For small spills to soil, all free product and contaminated soil must be dug up and disposed of in properly labeled containers available on-site.
- For a large spill, the spill must be contained to the extent possible using absorbent materials and building a berm around the area until a contractor can remove the materials.

A list of typical spill response equipment is provided below. It is a non-exhaustive list of some spill response supplies that would be appropriate to have at any site or in any vehicle where a spill may occur:

- sorbent booms to contain petroleum spills in water
- sorbent pads for soaking up petroleum spills
- cat litter or other absorbent non-combustible material
- shovels
- pails or barrels
- rubber boots
- gloves

All copies of this document are uncontrolled when printed.

- disposable coveralls
- emergency flagging or triangular reflectors

Excavated materials will need to be disposed of accordingly. The following local contractor can be contacted regarding collection and disposal of contaminated soils.

Northern Enviro Services
636 Alaska Hwy.
Watson Lake, YT
867-536-7361

3.4 Spill Reporting Notification Procedure

3.4.1 Internal Notification

All spills, regardless of volume, must be immediately reported to Legacy Dispatch at **250-427-6079**. The Dispatch will contact the Manager, Environmental Performance and the Site Manager.

3.4.2 External Notification

Releases of a substance into the environment that may cause, is causing or has caused an adverse effect to the environment, human health or safety, or property must be reported to the Yukon 24 Hour Spill Report Line immediately regardless of the volume. In addition, spills with quantities greater than those shown in Appendix B must be reported. Reporting a spill to the Yukon Spill Centre shall be done immediately when safe to do so and under the direction of the Manager, Environmental Performance.

Yukon Spill Centre **24 hr** **867-667-7244**

The Yukon Spill Centre phone line is monitored 24-hours per day. The operator will also notify all other concerned agencies when necessary. The following information shall be conveyed through the 24-hour spill report line.

- Location and time of the spill.
- Circumstances leading up to the spill.
- Type and quantity of material spilled.
- Details of any action taken at the spill site.
- Description of the environment at the location of the spill (e.g. terrain, watercourses, etc.).

Yukon Spills Regulations and Reporting Information is attached in Appendix C.

3.4.3 External Technical Advice - CANUTEC

The Canadian Transport Emergency Center (CANUTEC), a branch of Transport Canada, can also be contacted for 24-hour technical advice on Dangerous Goods, as needed.

CANUTEC – 24-hr helpline for dangerous goods **1-888-226-8832 or 613-996-6666**

All copies of this document are uncontrolled when printed.

3.5 Spill Incident Investigation

Upon resolution and completion of cleanup of a spill, an incident investigation must be conducted. The objective of the Investigation is to prevent a reoccurrence of an incident. The investigation will be coordinated by the Manager, Environmental Performance and may involve additional personnel depending on the nature of the incident and the investigator's technical or operational experience. Teck applies the Incident Cause Analysis Method (ICAM) investigation process. ICAM identifies systemic health, safety, or environmental deficiencies by providing a set of tools to examine the contributing factors that lead to incidents.

4.0 TRAINING

All Teck employees and Contractors working at the mine site should be familiar with this document. New employees and contractors will be introduced to the plan as part of their orientation. The orientation will include an overview of the potentially hazardous situations that spills can create to the health and safety of workers and the environment, and worker responsibilities to prevent, identify, report, and respond to a spill, including training on the use of spill kits. This document will be available for all workers. The company will advise workers of revisions or changes to the plan.

All Teck employees and Contractors must provide Safety Data Sheets (SDS) for all products that are used on-site or must be aware of where SDS are stored. All personnel must be aware of the contents of the SDS prior to working with products. Teck employees and contractors are trained in Workplace Hazardous Materials Information System (WHMIS) and Transportation of Dangerous Goods (TDG) prior to doing work on site.

APPENDIX A
INITIAL EVENT REPORT FORM

All copies of this document are uncontrolled when printed.

Initial Event Report

Event report must be submitted to Legacy Safety within 2 hours of the event.

This report is not intended to be comprehensive. The intention is to provide Teck with initial details to support Teck's response/investigation. The information contained in this report should be factual and not contain opinions or speculation.

EVENT DETAILS			
SITE NAME	EVENT LOCATION	EVENT DATE	EVENT TIME
EVENT DESCRIPTION <i>(provide as much detail as possible)</i>			
ACTIONS TAKEN <i>(including notifications)</i>			
WITNESSES <i>(name and contact info)</i>			
ENVIRONMENTAL EVENT DETAILS <input type="checkbox"/> Check if not applicable OR Check the following if applicable:			
Spill / Environmental Release of a substance / Permit Non-Compliance <input type="checkbox"/> Yes <input type="checkbox"/> No			
Geotechnical Incident <input type="checkbox"/> Yes <input type="checkbox"/> No Wildlife Injury / mortality / dangerous interaction <input type="checkbox"/> Yes <input type="checkbox"/> No			
MATERIAL SPILLED	QUANTITY SPILLED	SOURCE	
-	-	-	
SPILL WAS RELEASED TO			
<input type="checkbox"/> Ground <input type="checkbox"/> Air <input type="checkbox"/> Water <input type="checkbox"/> Drain <input type="checkbox"/> Other:			
DESCRIPTION OF SPILL LOCATION AND SURROUNDINGS			
DISTANCE TO NEAREST PUBLIC FACILITY, RESIDENCE, INDIGENOUS COMMUNITY	DISTANCE TO NEAREST STREAM, WATER BODIES, SENSITIVE AREAS	WILDLIFE / FISH IMPACTED POTENTIALLY RELATED TO A RELEASE OF A SUBSTANCE OR EXPOSURE OF MINE-AFFECTED WATER?	
-	-	<input type="checkbox"/> Yes <input type="checkbox"/> No	
PERSON/COMPANY IN CONTROL OF THE SUBSTANCE WHEN IT WAS SPILLED			
-			
INJURED PERSON DETAILS <input type="checkbox"/> Check if no person was injured			
NAME	EMPLOYER	POSITION/ROLE	
-	-	-	
PERSON COMPLETING REPORT			
NAME AND SIGNATURE		COMMENTS	
		-	

Form Routing:

Save file as <YYYY-MM-DD> <SITE ABBREV> Event Report – Description (e.g., 2022-02-01 SUL Event Report – Missing Person).
Email to Legacy.Safety@teck.com. Attach available supporting information (e.g., photos, witness statements, pre-task risk assessments, etc.). To ensure reporting deadline is met, supporting information may be submitted later as it becomes available.

All copies of this document are uncontrolled when printed.

APPENDIX B
YUKON SPILLS REGULATIONS - SCHEDULE A

All copies of this document are uncontrolled when printed.

SCHEDULE A

ITEM	COLUMN 1 - SUBSTANCE SPILLED	COLUMN 2 - SPECIFIED AMOUNT
1.	Explosives of Class 1 as defined in section 3.9 of the Federal Regulations	any amount
2.	Flammable gases, of Division 1 of Class 2 as defined in section 3.11(a) of the Federal Regulations	Any amount of gas from a container larger than 100L, or where the spill results from equipment failure, error or deliberate action or inaction
3.	Non-flammable gases of Division 2 of Class 2 as defined in section 3.11(d) of the Federal Regulations	Any amount of gas from a container larger than 100L, or where the spill results from equipment failure, error or deliberate action or inaction
4.	Poisonous gases of Division 3 of Class 2 as defined in section 3.11(b) of the Federal Regulations	any amount
5.	Corrosive gases of Division 4 of Class 2 as defined in section 3.11(c) of the Federal Regulations	any amount
6.	Flammable liquids of Class 3 as defined in section 3.12 of the Federal Regulations	200 L
7.	Flammable solids of Class 4 as defined in section 3.15 of the Federal Regulations	25 kg
8.	Products or substances that are oxidizing substances of Division 1 of Class 5 as defined in sections 3.17(a) and 3.18(a) of the Federal Regulations	50 kg or 50 L
9.	Products or substances that are organic compounds that contain the bivalent "-O-O-" structure of Division 2 of Class 5 as defined in sections 3.17(b) and 3.18(b) of the Federal Regulations	1 kg or 1 L
10.	Products or substances that are poisons of Division 1 of Class 6 as defined in sections 3.19(a) to (e) and 3.20(a) of the Federal Regulations	5 kg or 5 L
11.	Organisms that are infectious or that are reasonably believed to be infectious and the toxins of these organisms as defined in sections 3.19(f) and 3.20(b) of the Federal Regulations	any amount
12.	Radioactive materials of Class 7 as defined by section 3.24 of the Federal Regulations	any discharge or a radiation level exceeding 10 mSv/h at the package surface and 200 mSv/h at 1 m from the package surface
13.	Products or substances of Class 8 as defined by section 3.24 of the Federal Regulations	5 kg or 5 L

ITEM	COLUMN 1 - SUBSTANCE SPILLED	COLUMN 2 - SPECIFIED AMOUNT
14.	Miscellaneous products or substances of Division 1 of Class 9 as defined by sections 3.27(1) and 2(a) of the Federal Regulations	50 kg or 50 L
15.	Miscellaneous products or substances of Division 2 of Class 9 as defined in section 3.27(1) and 2(b) of the Federal Regulations	1 kg or 1 L
16.	Miscellaneous products or substances of Division 3 of Class 9 as defined in section 3.27(1) and 2(c) of the Federal Regulations	5 kg or 5 L
17.	Special waste as defined in section 1 of the Special Waste Regulations	amounts specified in s. 3(1)(b) of Special Waste Regulations
18.	A pesticide as defined in section 2 of the <i>Environment Act</i> , but not including those pesticides and fertilizers listed in Schedule 4 of the Pesticide Regulations	5 kg or 5L
19.	Pesticides and fertilizers listed in Schedule 4 of the Pesticide Regulations	any amount

APPENDIX C
YUKON SPILLS REGULATIONS AND REPORTING INFORMATION

All copies of this document are uncontrolled when printed.



Spills Regulations and Reporting

Spills, unfortunately, do happen, and some spills need to be cleaned up right away. When hazardous substances such as fuel oil are spilled, the environment and public health can be harmed if action is not taken.

The *Environment Act* and the *Spills Regulations* outline what types and sizes of spills must be reported. Spills of hazardous substances must be reported regardless of the volume if they are abnormal in quality or quantity. If you're not sure, report it!

When a Spill Occurs

You must take these steps **as soon as possible under the circumstances** after a spill has been identified:

1. Report the spill to the Yukon Spill Report Centre or an Environmental Protection Officer. Spills occurring anywhere in the Yukon should be reported to the **Yukon Spill Report Centre at (867) 667-7244**. This number is maintained by the Yukon Government 24 hours per day, and collect calls are accepted. The Spill Report Centre will gather information such as:
 - the location and time of the spill;
 - the circumstances leading up to the spill;
 - the type and quantity of material spilled;
 - details of any action taken at the spill site; and
 - a description of the environment at the location of the spill (e.g. terrain, watercourses, etc.)
2. Notify the owner or person in charge of the spilled substance and any person who may be adversely affected by the spill.
3. Take all reasonable measures to confine the spill.
Measures may include actions such as the following, if it is safe and appropriate to do so:
 - stopping the release of any more of the spilled substance by turning off valves, picking up fallen containers, etc.;
 - putting down absorbent material;
 - building berms or ditches to stop spilled material from spreading; etc.
4. Restore the site to the same condition that it was in before the spill.
Environmental Protection Officers may provide direction regarding actions to be taken to restore the site, including sampling to show that no contamination remains.

Last Resort

If the person responsible for the spill does not attempt to confine the spill or to restore the site, an Environmental Protection Officer has the authority to order the responsible person to take action.

If the responsible person still does not act, the Environmental Protection Officer has the authority to ensure that the site is cleaned up, and any costs incurred will be billed to the person responsible for the spill.

More detailed information can be found in Part 11 of the *Environment Act*, and in the Spills Regulations.

Other Topics

Fact Sheets are also available on the following topics:

- Spill Response Plans
- Contaminated Sites
- Storage of Special Wastes

For more information on the Spills Regulations, please contact:

Environmental Programs Branch
Department of Environment (V-8)
Box 2703
Whitehorse, Yukon
Y1A 2C6

Phone: (867) 667-5683
Toll Free: 1-800-661-0408 extension 5683
Fax: (867) 393-6205
E-mail: envprot@gov.yk.ca

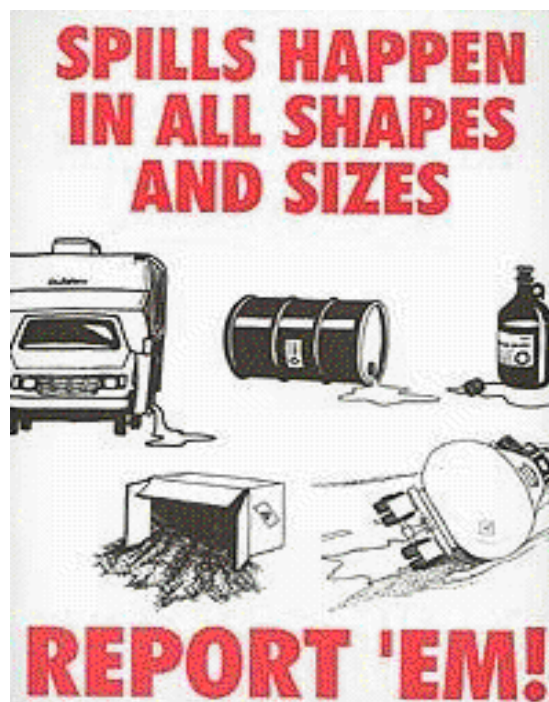

Copies of Yukon regulations may be viewed online at <http://environmentyukon.gov.yk.ca/monitoringenvironment/> under the "Standards & Approvals" section, or at any Yukon Public Library, territorial agent, territorial representative or regional services office. You may purchase copies at the Inquiry Centre, Yukon Government Administration Building, 2071-2nd Avenue in Whitehorse, or by mail from the Subscriptions Clerk, Yukon Government Queen's Printer, Box 2703, Whitehorse, Yukon, Y1A 2C6 (phone (867) 667-5783 or toll free 1-800-661-0408 extension 5783).

APPENDIX F
MINE EMERGENCY RESPONSE PLAN

Sä Dena Hes Mine

Mine Emergency Response Plan

February 1, 2024

Legacy
Properties

Teck

TABLE OF CONTENTS

SECTION 1.0	Acronyms and Definitions	4
SECTION 2.0	Plan Administration	7
2.1	Policy Directive.....	7
2.2	Facility Description	8
2.3	Objectives and Priorities	9
2.4	Authorities & References	10
2.5	Maintenance.....	10
2.6	Risk Management	10
2.7	Planning	12
2.8	External Engagement.....	12
2.9	Public and Media Relations.....	14
2.10	Department Operations Centre.....	14
2.11	Emergency Operations Center	14
2.12	Training & Awareness	14
2.13	Exercises.....	15
SECTION 3.0	Emergency Response Procedures	16
3.1	Step 1 – Event Detection	16
3.2	Step 2 – Emergency Level Determination	16
3.3	Step 3 – Emergency Notification and Communication Plan	20
3.4	Step 4 – Emergency Response Actions	23
3.5	Step 5 - Event Termination and Follow-Up.....	26
SECTION 4.0	Roles and Responsibilities.....	27
4.1	Accountabilities, Roles, and Responsibilities.....	27
4.2	EMT Organizational Chart.....	29
SECTION 5.0	Useful Documents.....	30
5.1	Useful Documents.....	30
5.2	Authority for Expenditure.....	31
SECTION 6.0	Contacts	32
6.1	External Contacts.....	32
6.2	Internal Contacts	39
Appendix A	Tailings and Water Retaining Structures	42
Appendix A	Tailings Facilities.....	43
A.1.	Project Affected People (PAP) and Communities of Interest (COI).....	43
A.2.	MERP Activation and Boundary between MERP and OMS	45
A.3.	Failure Modes and Risk Assessment.....	46
A.4.	Preventive & Remedial Actions.....	49
A.5.	Links to Reference Documents for Tailings Related Emergencies.....	51

All copies of this document are uncontrolled when printed.

Appendix B	Commonly Used Documents	52
B.1	TLP Emergency Event Termination Report	53
B.2	TLP Emergency Event Report	53
B.3	TLP Emergency Event Recovery Plan.....	53
Appendix C	Maps	54
C.1	SDH Mine Site Map.....	55
C.2	SDH Site Overview	56
C.3	SDH to Watson Lake Community Hospital Route.....	57
C.4	SDH Helipad Access Locations	58
Appendix D	Evacuation Plan	59
D.1	SDH Evacuation Route to Watson Lake	61
Appendix E	Infrastructure at Risk	62
E.1	Teck-Owned Infrastructure.....	63
E.2	External Agency-Owned Infrastructure	63
Appendix F	Other Available Resources	64
F.1	Other Available Resources	65
Appendix G	Public and Media Relations Management	66
G.1	Public and Media Relations.....	67

SECTION 1.0 ACRONYMS AND DEFINITIONS

ACRONYMS

Acronym	Definition
AFPR	Annual Facility Performance Review
ALARP	As Low As Reasonably Possible
CCT	Crisis Communication Team
CDA	Canadian Dam Association
CISM	Critical Incident Stress Management
CMT	Crisis Management Team
COI	Communities of Interest
CSA	Canadian Standards Association
DFO	Department of Fisheries and Oceans
DOC	Department Operations Centre
DSR	Dam Safety Review
ECCC	Environment and Climate Change Canada
EHSC	Environment, Health, Safety, and Community
EMT	Emergency Management Team
EOC	Emergency Operations Centre
EOR	Engineer of Record
EPD	Environmental Protection Division
EPP	Emergency Preparedness Plan
EPRP	Emergency Preparedness and Response Plan
ERP	Emergency Response Plan
FLHA	Field Level Hazard Assessment
FN	First Nations
GISTM	Global Industry Standard for Tailings Management
HPRC	High Potential Risk Classification
HSRC	Health, Safety, and Reclamation Code
IAP	Incident Action Plan
IC	Incident Commander

All copies of this document are uncontrolled when printed.

ICMM	International Council on Mining & Metals
ICP	Incident Command Post
ICS	Incident Command System
ISO	Incident Safety Officer
ITRB	Independent Tailings Review Board
MAC	Mining Association of Canada
MCE	Maximum Credible Earthquake
MERP	Mine Emergency Response Plan
OMS	Operation, Maintenance, and Surveillance
PAP	Project Affected People
PEARL	People, Environment, Assets, Reputation, and Livelihood
PIO	Public Information Officer
PMF	Probable Maximum Flood
RTFE	Responsible Tailings Facility Engineer
SAR	Search and Rescue
TARP	Trigger Action Response Plan
TGR	Tailings Governance Review
TIA	Tailings Impoundment Area
TIPP	Turn In Poachers and Polluters
TLP	Teck Legacy Properties
TMA	Tailings Management Area
TMS	Tailings Management System
TNA	Training Needs Analysis
TSB	Transportation Safety Board
TSF	Tailings Storage Facility
TWG	Tailings Working Group
TWRS	Tailings and Water Retaining Structures
UC	Unified Command
WHMIS	Workplace Hazardous Material Information System

All copies of this document are uncontrolled when printed.

DEFINITIONS

Crisis Communications Team – Internal designation for the corporate team responsible for all media and public relations communications during an emergency.

Corporate Affairs Team – Internal designation for the corporate team responsible for all media and public relations communications during an emergency. When dealing with the public during a crisis situation we refer to our Crisis Communication Team as the ‘Corporate Affairs Team’.

Critical Incident Stress – Critical incident stress refers to the range of physical and psychological symptoms that might be experienced by someone because of being involved in a traumatic critical incident. Critical incident stress is simply the body's normal reaction to an abnormal event.

A traumatic critical incident – A traumatic critical incident is any incident during which a person experiences, witnesses, or is confronted with serious injury, death, mass casualties; any incident in which a person's life has been imperiled or threatened; or any situation that is recognized at the time to have the potential to significantly interfere immediately or at a later time with a person's ability to function professionally or personally.

Communities of Interest - Any of those who may be impacted by, have interest in, or can influence Teck's legacy sites.

Project Affected People - Are people who may experience impacts from a tailings facility and/or who directly bear the impacts of a tailings failure, and their involvement ensures that their rights, concerns, and well-being are upheld.

SECTION 2.0 PLAN ADMINISTRATION

2.1 Policy Directive

Teck Resources Limited and its group of companies is committed to achieving operational excellence and continuous improvement by responsibly managing its risks across the entire organization and globally.

Management is committed to having an appropriately resourced emergency response plan for each location within Teck's global footprint to effectively manage an emergency event. These plans will meet both regulatory and industry standards and will be exercised on an annual basis.

Teck recognizes Mine Emergency Response Plans (MERP) are a vehicle for understanding the hazards at our locations and the risks they may present to people, the environment, our assets, and our reputation. Management expects all staff to understand how to respond to an emergency and to work towards eliminating these risks while continuously scanning our business environment for new risks and threats that appear as our business evolves.

The Site Manager will be responsible for ensuring these plans exist, are relevant, and that staff are trained in their use. The Emergency Response Coordinator, the Mine/Site Manager, or a trained and competent designate will lead the Emergency Management Team (EMT) as the Incident Commander. The Sä Dena Hes Mine is a closed facility with no permanent on-site staff. The site is managed by the Teck Legacy Properties (TLP) Team in Kimberley, BC. The Teck Legacy Properties Emergency Management Team is ICS-trained and qualified to lead responses to any emergency at the Sä Dena Hes Mine. At no time will the Sä Dena Hes Mine site be without someone to lead the emergency response as the Incident Commander.

Emergency response procedures and action plans will be created for known and potential hazards after collaborative and comprehensive consultation with external stakeholders, whether they be the emergency services, local communities, key partners, or industry and subject matter experts. Training will be carried out annually, or more frequently if required by the nature of the threat or local regulations, for everyone with a named responsibility, including those nominated as alternates.

Our emergency preparedness and crisis management planning are the cornerstone of our response effectiveness and have been endorsed by our Board of Directors and Executive Team.

2.2 Facility Description

Name of Site	Sä Dena Hes
Address of Site	No civic address, refer to below coordinates.
Longitude	128°53'W
Latitude	60° 35'N
Mine / Site Manager	Ray Proulx
Access to Site	<p>1.0 The mine site is reached via the Robert Campbell Highway, north of Watson Lake. At approximately kilometer 47 of the Robert Campbell Highway, a 25 km access road extends to the mine property. The site access road is normally not accessible for wheeled vehicles in the winter due to snow not being plowed.</p> <p>2.0 If accessed by helicopter, the site is located 45 km from the Watson Lake airport, due north (approximate heading 357 degrees). Helipad and access location coordinates can be found in Appendix C: Maps</p>
Contact Person/Phone to Access Site	TLP Dispatch: 1-250-427-6079
Traffic Entry Points	<i>See Appendix C: Maps</i>
Site Communication Requirements	SAT phone, InReach, 2-way radios
Approximate Number of People on Site	Normally no one on site. In summer may have 4 to 8 people periodically if project work occurring.
Nature of Site	The Sä Dena Hes mine site is in the Closure – Active Care phase of mine life. The only remaining tailings retaining embankment is the North Embankment. Other structures include reclaimed waste rock dumps and closed portals.
Brief Explanation of Daily Site Activity	Normally no one is on site other than routine environmental sampling events. In summer there may be intermittent project work occurring with a variable number of personnel present.

All copies of this document are uncontrolled when printed.

2.3 Objectives and Priorities

This Mine Emergency Response Plan (MERP) sets out actions required in the event of an emergency at the Sä Dena Hes Mine site. While it is not intended for this MERP to cover every emergency in detail, it does set out the basic steps to be followed at the Sä Dena Hes Mine site.

The top priority for this plan is for the protection and preservation of life, the environment and property. This MERP is an effective mechanism for escalating an incident to the Corporate Crisis Management Team, located in Vancouver, when necessary.

The four prime objectives of this plan are to ensure:

- emergency information is available and can be relied upon.
- emergency response procedures are developed, understood, relevant and documented.
- emergencies are managed to defined protocols.
- emergencies are reported according to defined company, legal and regulatory requirements.

This MERP supports the Emergency Management Team and Emergency Response Team in coordinating, and leading all actions and interventions required to provide an effective first response and resolution to emergencies.

This MERP documents the resources and strategies (based on risk scenarios) to address the immediate response to an emergency. It identifies site hazards and their potential effects, roles and responsibilities of internal and external responders, emergency event pre-planning activities, such as stakeholder identification and contact confirmation, notification procedures to all stakeholders and responders, frequency of testing the MERP, and procedures for the administration and update of the MERP to maintain preparedness for all types of emergency events.

The inclusion of the plan components listed above ensures this MERP conforms to the requirements of the Global Industry Standard on Tailings Management, GISTM (GTR 2020). Specific elements related to tailings facilities (for sites where they exist) are included in [Appendix A](#) and taken in totality with the information included in the body of the document forms the tailings Emergency Preparedness and Response Plan (EPRP).

2.4 Authorities & References

2.4.1 Legislation

The following legislation applies to the Sä Dena Hes Mine.

Area	Law	Regulation/Statute	Guidelines
YK	Quartz Mining Act QML-0004		License is for the reclamation, remediation, closure and post closure and maintenance related to the production and development that occurred at the Sä Dena Hes Mine Site
YK	Yukon Waters Act and Waters Regulation - Water License - QZ16-051		To store/alter flow of water associated with maintenance and decommissioning activities and to deposit a waste to water
CAN	Reference: CDA Guidelines (Tailings management)		Reference: A Guide to the Management of Tailings Facilities

2.5 Maintenance

This plan will be reviewed at least annually by the Emergency Response Coordinator, the Site Manager, and the Responsible Tailings Facility Engineer, where applicable, as well as following any incident or exercise that provides suggestions for improvements. The annual revisions will focus on ensuring the factual content such as contact information and nominated personnel is correct.

2.6 Risk Management

A Risk Management Process (RMP) has been established for all mines managed by Teck Legacy Properties. Site risk registers have been created which contain inputs into existing business processes, in order to reduce the effect of uncertainty on business objectives and enhance resiliency should an unwanted event occur. RMP also supports strategic business planning and prioritization, emergency response planning, personnel and financial resource allocation, and informed decision making. The RMP involves consistent practice in **hazard, risk, and vulnerability identification, analysis, and evaluation** as well as the subsequent application of **controls** and additional activities to verify **control effectiveness**. It is a continual and iterative process that occurs in parallel with, and informs, other business processes. Persons who attend the Sä Dena Hes Mine are required to complete an orientation which provides hazard, risk, and vulnerability identification and control information.

All copies of this document are uncontrolled when printed.

The following hazards, risks, and vulnerabilities are part of the Sä Dena Hes Mine risk register and are managed using the appropriate response actions located in [Section 3.4](#).

Identified potential threats managed by emergency response actions contained in Section 3.4
Aviation Incident
Avalanche Event
Flooding Event
Hazardous Material Spill
Missing Persons
Mobile Equipment Collision
Natural Disaster
Subsidence/Wall Failure
Tailings Storage Facility Embankment Failure
Unusual Event Causing Multiple Casualties/Severe Trauma/Fatality
Wildfire Event
Wildlife-Related Event
Working On/Near Water/Ice, Near Drowning

2.7 Planning

Emergency response programming has been developed by the Emergency Response Coordinator with consultation from internal subject matter experts and by those who are directly responsible for the area most directly affected. Input and feedback will be sought by other site departments or functions who will also be affected.

2.8 External Engagement

Teck recognizes emergencies do not exist only within a worksite, and from time to time, depending on the nature of the emergency, may impact external stakeholders such as the emergency services, local communities, and authorities. Feedback, input, and ideas will be sought from these stakeholders as part of producing effective procedures and action plans.

External engagement is actioned during the planning stages of this document. Engagement consists of reviewing mine site hazards, risks, and vulnerabilities and current controls as well as the external groups roles/responsibilities during an emergency. It is important that the below listed groups be involved in pre-planning to ensure they are aware of site hazards, avoid conflicting responsibilities during an emergency and ensure clear communication is provided.

All engagement activities are tracked internally using Teck's Trackline system along with other internal information tracking practices. Information tracked with regards to these engagement activities includes, at a minimum, the date and location of the engagement, topics discussed, questions received and resolved, and session participants. External stakeholders may request information on these engagements by contacting the Sä Dena Hes Site Manager or the Legacy Social Performance and Communities Team.

The following lists are not exclusive regarding engagement activities with Teck Legacy Properties. Other individuals, agencies, or organizations may have also been part of engagement activities but may not be reflected in the lists below.

2.8.1 First Responder Engagement

Agency	Jurisdiction	Responsibility
Yukon Territory Emergency Measures	Yukon Territory	Territorial management and coordination related to large scale emergency events
Watson Lake RCMP	Watson Lake and area including Sä Dena Hes	Protective services, criminal investigations, security
Watson Lake Fire Department	Watson Lake and area including Sä Dena Hes	Fire and rescue services
Watson Lake Ambulance	Midway and area including Sä Dena Hes	Triage, treatment, and transport of victims of emergency events
Yukon Search & Rescue	Yukon Territory	Search & rescue services

2.8.2 Affected Community Engagement

Agency/Organization/Municipality
Residents of Watson Lake and the public who use areas close to the Sä Dena Hes mine for access and/or leisure activities (e.g., walking, cycling)
Owners of hunter guiding, trapping, and fishing enterprises located near the Sä Dena Hes mine

2.8.3 Indigenous People Engagement

Indigenous People
Liard First Nations

2.9 Public and Media Relations

In the event of a serious incident that becomes of interest to the public or the media, all communications will be directed by the Teck Corporate Crisis Communication Team. A local Public Information Officer (PIO) will be established and communications regarding the incident will be provided by the Crisis Communication Team through the PIO. General procedures for addressing calls from the public or media calls or on-site media arrivals can be found in [Appendix G](#).

2.10 Department Operations Centre

To effectively manage emergencies, a Department Operations Centre (DOC) will be established for Medium-Level and High-Level emergencies. The following are suggested locations for the DOC.

Location	Description and Location of Resources
Teck Main Office - Board Room 601 Knighton Road, Kimberley, BC	Board room table that seats 12 people, whiteboard, phones, computers, maps, mounted TV capable of mirroring computer. Multiple break out offices, lunchroom and 2 bathrooms.
Central Shops – Training Room 400 Jim Ogilvie Way, Kimberley, BC	Multiple tables that seat >20 people, whiteboard, phones, large wall space, computers, maps, mounted TV capable of mirroring computer. Breakout areas available, lunchroom and 4 bathrooms.

2.11 Emergency Operations Center

Emergency Operations Centers (EOCs) are organized by external functional disciplines (e.g., fire, law enforcement, or medical services), by jurisdiction (e.g., federal, provincial, regional, or municipal), or by some combination thereof. Provincial, Regional, or State emergency response personnel are responsible for the establishment of the EOC. Establishment of an EOC may assist the local Emergency Management Team in coordinating a unified response to a major emergency with external support such as the Emergency Services, Local Authorities, and communities. If an emergency occurs where an EOC is established and Teck is a key stakeholder, the EOC may request a Teck liaison person to relay information from EOC to Teck’s DOC.

2.12 Training & Awareness

Training will be used to communicate details, roles, and responsibilities of the emergency response planning. Training will seek to increase awareness, skills, and competency in emergency response capabilities. Emergency Response and Management Teams will be trained and maintained for all sites.

A Training Needs Analysis (TNA) is maintained for Legacy Properties personnel. This TNA identifies what training is required for employees, contractors, visitors and first responders. All training will have clear

All copies of this document are uncontrolled when printed.

objectives and will seek to make the best use of time available and minimize disruption to normal business activity.

2.13 Exercises

Teck Legacy Properties maintains an Emergency Response Exercise Program for training and testing purposes. The program is available for review on request. The program is developed by the Emergency Response Coordinator and contains the following major components:

- Purpose and Objectives
- Hazards, Risks, Vulnerabilities, and the Four Phases of Emergency Management
- Response Organization
- Exercise Development and Evaluation
- Exercise Documentation
- Roles and Responsibilities
- Core Competencies
- Logistical Considerations
- Resource Management Plan
- Documentation Management Plan
- Communications Management Plan
- Budget
- Training Plan and Program Schedule (5-year testing plan)
- Exercise records with After Action Report/Improvement Plans

Testing and updating the MERP occurs on a frequency that meets the requirements of GISTM and applicable regulatory agencies. All documented learnings are used to inform and update the MERP state of readiness and to direct future training. Testing and updates will be performed more frequently if required by a material change in the mine site, its tailings facility (if present), or the social, environmental, and local economic context.

SECTION 3.0 EMERGENCY RESPONSE PROCEDURES

Establishing a set response procedure that applies to all emergencies ensures that vital actions are not missed and mitigates risk of human error which could exasperate the incident or create another incident and increase loss.

There are five steps of emergency response procedures as shown below. These steps are described in detail in the following sections:

- Step 1 – Event Detection
- Step 2 – Emergency Level Determination
- Step 3 – Emergency Notification and Communication Plan
- Step 4 – Emergency Response Actions
- Step 5 – Termination and Follow-up

3.1 Step 1 – Event Detection

This step describes the detection of an unusual or emergency event and provides information to assist TLP site personnel in determining the appropriate emergency level for the event.

Unusual or emergency events may be detected by:

- observations on site property or in buildings and facilities by employees/contractors.
- notification of observations made by the public of an event or condition originating from the mine site.
- notifications from employees/contractors of witnessed environmental, health & safety, and human behavioral events.

Procedure for reporting events:

- Report all unusual or emergency events to TLP Dispatch 1-250-427-6079 or 1-855-899-6857.
- Provide your name, nature of the emergency, location of the emergency, potential for emergency to escalate and affect other areas, actions being taken to control the emergency, and contact number for follow-up and further status reports.

3.2 Step 2 – Emergency Level Determination

The actual or potential consequences of events will be classified under one of the three levels below as part of Teck's Crisis Management Assessment Guide, which is described in more detail on the following pages:

- **Low Level** emergency is a non-urgent, unusual event that is slowly developing. This event is *not* normal but has not yet threatened the operation of the site or structural integrity of any tailings embankments/facilities. This event could escalate if left unchecked.
- **Medium Level** emergency applies when conditions exist that have or are likely to have a significant effects on buildings, roads, environment, and infrastructure, or pose a significant risk to the health, safety, or welfare of people and assets.
- **High Level** emergency applies when conditions exist that have caused a significant, damaging effect on buildings, roads, environment, and infrastructure or have caused a significant damage to the health, safety, or welfare of people. The event threatens the operation of the site and could have catastrophic consequences for the company and industry.

All copies of this document are uncontrolled when printed.

Sä Dena Hes Mine Mine Emergency Response Plan

At Teck, Trigger Action Response Plan (TARP) and Event Driven Criteria are practiced under the site's Operation, Maintenance and Surveillance (OMS) Manual. This information informs levels of emergency and actions related to tailings and water retaining structures. The boundary between MERP and OMS is clearly defined by the activation of MERP determined by the Site Manager (or designated). A flow chart contained in [Appendix A](#), A.2 assists in defining activation and establishing the operational boundary between the MERP and the OMS.

3.2.1 Teck's Crisis Management Assessment Approach

To ensure consistency in the assessment of potentially damaging events and issues throughout Teck, standardized notification and escalation “thresholds” have been developed. These thresholds are set out in a Crisis Management Assessment Guide for ease of use (see following page). Teck prefers to operate on the principle of preparing for the worst while hoping for the best, relying on early activation to ensure timely notification, tracking, management, and response.

All potentially damaging events / issues should be evaluated against the Crisis Management Assessment Guide to determine the appropriate level of escalation. The Crisis Management Assessment Guide provides a description of the potential types and/or outcomes of events, a measurement of severity and the teams that would potentially be involved for each. Once a team is notified of an incident, it is their responsibility to refer to the Crisis Management Assessment Guide and determine the requirement for activation of further teams in the next level of the organization.

To use the Crisis Management Assessment Guide, the following steps should be taken:

1. Identify all the relevant incident/issue outcomes from the list in the left-hand column of the Crisis Management Assessment Guide.
2. For each outcome, determine the description (from the boxes to the right of the outcome) that best describes the severity. If there is uncertainty over a severity level, always select the higher ranking to ensure adequate notification and response.
3. The outcome registering the highest severity determines the overall severity ranking of the event.

NOTE: Non-operational issues may result in a High severity ranking and may not involve Emergency Response Team or Site Management Team.

Where an outcome occurs that is not covered by the Crisis Management Assessment Guide, the team consulting the Crisis Management Assessment Guide must make an assessment regarding the appropriate level of notification / escalation based on their best judgment.

Each outcome has been rated against the company's response priority acronym, known as **P.E.A.R.L.**, which must be reflected in any response:

People – protect the health, safety, and wellbeing of those involved or affected (e.g., first responders, emergency response teams, impacted employees and contractors and affected communities) including impact minimization and recovery.

Environment – protect, preserve, and restore the environment.

Assets – repair property and process damage and offset production losses to the extent practical.

Reputation – preserve and, where possible, enhance the company's reputation.

Livelihood – return to safe operating conditions as quickly as possible.

Use of this Crisis Management Assessment Guide provides a consistent, non-subjective assessment and escalation / notification decision making process. Consistent use and application of this Crisis Management Assessment Guide aims to ensure that notifications occur uniformly, regardless of where an event or issue originates.

If response is required by any Team, then that Team must notify the next ascending Team.

All copies of this document are uncontrolled when printed.

Crisis Management Assessment Guide

		Low	Medium	High
✓	Response by	Site Management and / or Emergency Response - Usual business reporting applies	Site Management Team Activation (notification to Corporate Crisis Management Team)	Site Management Team and / or Corporate Crisis Management Team Activation
	Outcome			
PEOPLE				
	Injury / health	Recordable injury involving hospitalization. Localized and contained outbreak of communicable disease.	Life-threatening or life-altering injury. Epidemic outbreak of a communicable disease. WHO-designated pandemic in nearby countries.	Single or multiple fatalities / mass casualties. WHO-designated pandemic in-country of operation.
	Missing / trapped personnel	Unconfirmed report of people / person missing or trapped.	People / person missing or trapped but confirmed alive and uninjured.	People / person confirmed missing or trapped and not responding or able to make contact.
	Security (Physical)	Unconfirmed report of threat against individuals / infrastructure / assets requiring investigation. Potential civil unrest.	Confirmed threats against individuals, infrastructure or assets requiring intervention. Civil unrest, or need for significant security changes, impacting a single site.	Kidnap or extortion demand or actions involving harm to individuals. Campaign of civil unrest, or a need for significant security changes, impacting multiple sites.
	Community impacts	Localized low-level impact requiring site resources and communication with external stakeholders.	Localized impact, exceeding site resources, requiring communication and coordinated external assistance. Damage to an item of cultural significance.	Significant impact affecting the company's social license to operate. Destruction of irreplaceable item or location of cultural significance.
ENVIRONMENT				
	Environmental impact	Event that requires regulatory reporting with no potential for off-site impacts. Permanent or irreversible impact to a common species or ecosystem element	Long-term impact/destruction to biodiversity and/or ecological resources beyond applicable boundaries. Lingering but reversible damage to rare or valued species or vulnerable ecosystem.	Significant off-site impacts, exceeding site's response capability. Permanent, irreversible impact to a rare or valued species or vulnerable ecosystem or habitat
ASSETS				
	Technical damage / recovery	Geotechnical or infrastructure failure not affecting site operations plan, nor requiring a formal recovery plan / recovery project team.	Geotechnical or infrastructure failure affecting site operations plan, requiring a formal recovery plan / recovery project team.	Geotechnical or infrastructure failure impacting operations such that it would require revising overall company guidance / outlook to market.
	Loss of control of communications / IT / data / control systems	Outage of critical site system(s) within site capability to quickly restore / recover, and within maximum acceptable outage.	Outage / cyber-attack to critical site systems resulting in sensitive data theft / loss or exceeding maximum acceptable outage.	Outages / targeted cyber-attack / sensitive data theft / loss affecting multiple sites or with potential to impact multiple sites.
	Impact to production / project execution	Operational or asset impairment, with continued operations relying on alternative means or spare capacity.	Operational or asset impairment up to one month without alternative means for continued operations. Impact \$25-50m.	Long-term or permanent operational or asset impairment without alternative means for continued operations. Impact >\$50m.
	Contractor, supply chain, partner impact	Potential interruption to critical suppliers, essential services or equipment needs.	Critical contractors, suppliers or essential services disrupted with impact to operations.	Critical contractors, suppliers or essential service partner(s) in crisis impacting multiple sites.
REPUTATION				
	Media / social media	Local and/or regional media interest. 100s of social media posts. Shift or transition in relationship with key influencer(s).	National media interest. 1,000s of social media posts, including posts or statements by key influencer(s). Abrupt step-change in relationship with key influencer(s).	Event attracting international mainstream media. 10,000s of social media posts. Transformative change in relationship with key influencer(s).
	Breach of ethics	Informal allegations of improper or unethical behavior.	Formal allegations of improper or unethical behavior.	Formal charges by enforcement agency involving unethical behavior.
LIVELIHOOD				
	Regulatory action	Regulatory interest with potential impact to site operations.	Regulatory action with potential to impact site operations for one month. Impact \$25-50m.	Regulatory action with potential to impact one or more operations for longer than one month. Impact >\$50m.
	Government order / legislative action	Government interest not impacting site operations.	Government order / legislation negatively impacting operations or life-of-mine plan for a single operation or project.	Government sanction, action, order or legislation halting operation or project. Critical operating permits indefinitely revoked or denied. New laws jeopardizing economic viability.
	Labor relations / action	Higher than normal intelligence suggesting labor disruption.	Actual labor disruption impacting site operations or production for more than one shift.	Labor disruption impacting operations or production for more than 48 hours.
	Loss of senior personnel	Incident or illness to site senior manager not affecting site management capabilities.	Normal operational management capabilities adversely impacted at site.	Succession challenges adversely impacting the company's corporate management capabilities.
	Legal issue	Informal allegations against the company of illegal acts.	Allegations of illegal acts with police intervention. Legal action by or against the company with potential to impact continuity of operations at one location.	Charges of illegal acts resulting in police intervention. Legal action by or against the company with potential to impact continuity of operations at multiple sites.

All copies of this document are uncontrolled when printed.

3.3 Step 3 – Emergency Notification and Communication Plan

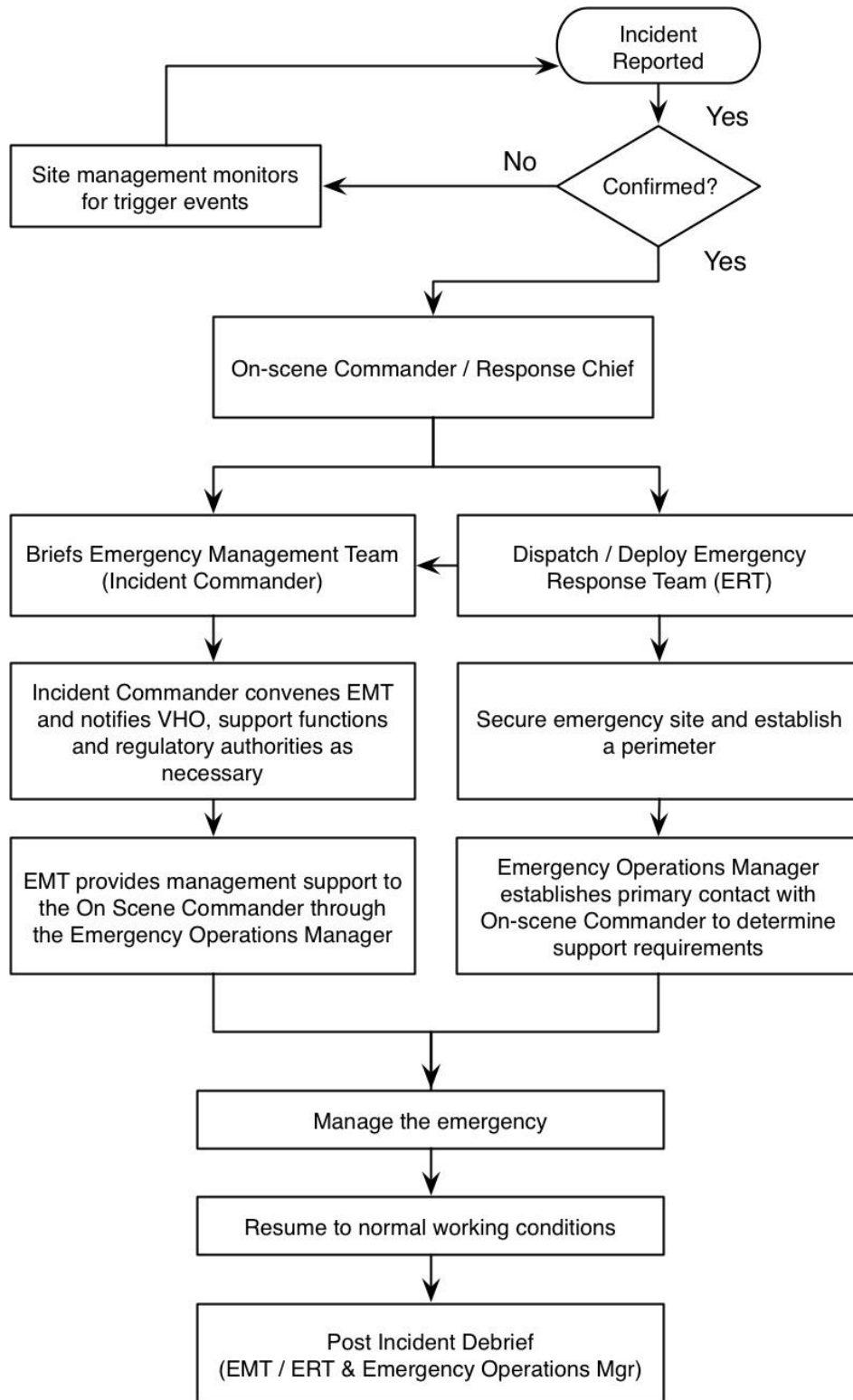

All copies of this document are uncontrolled when printed.

3.3.1 Emergency Response Flow Chart and ICS Position Responsibilities

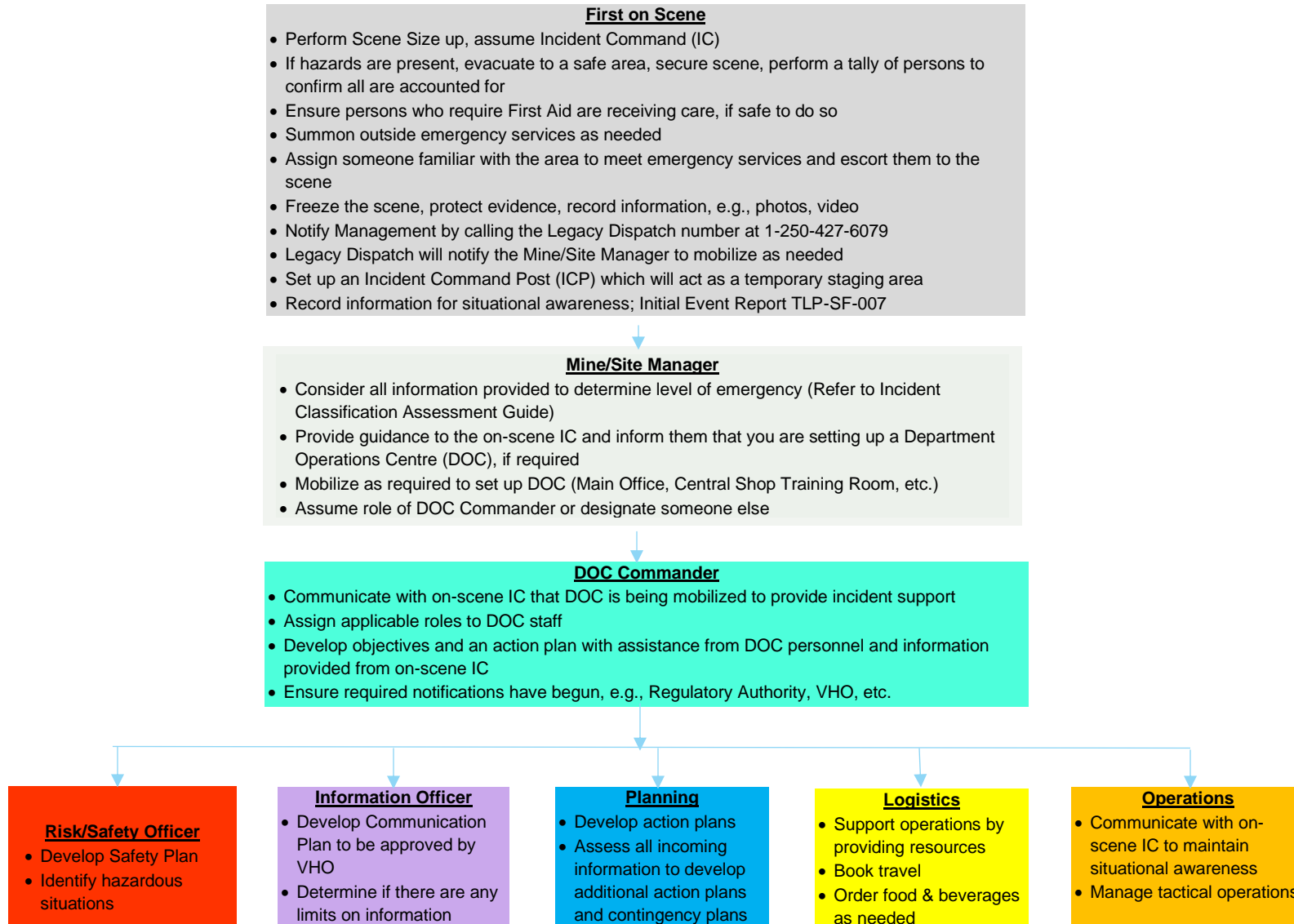

All copies of this document are uncontrolled when printed.

3.3.2 Legacy Emergency Notification Chart

Table 3.1 ERP Notification Chart for All Emergency Levels at YK Sites

See *SDH Stakeholder Identification Board* for detailed callout lists.

Responsible Entity	Low Level	Medium Level	High Level
	<i>Slowly Developing, Unusual Event</i>	<i>Hazardous Situation, Rapidly Developing, Potential significant effects to people, environment, assets, reputation, and livelihood</i>	<i>Urgent, Emergency, Significant immediate effects to people, environment, assets, reputation, and livelihood</i>
Observer of Emergency Incident	<ul style="list-style-type: none"> Notify Local Emergency Response Agencies, as required. Notify Legacy Dispatch of the event. Remain on site and in contact with Legacy. Dispatch to provide further assistance, if required. 	<ul style="list-style-type: none"> Notify Local Emergency Response Agencies, as required. Notify Legacy Dispatch of the event. Remain on site and in contact with Legacy Dispatch to provide further assistance, if required. 	<ul style="list-style-type: none"> Notify Local Emergency Response Agencies, as required. Notify Legacy Dispatch of the event. Remain on site and in contact with Legacy Dispatch to provide further assistance, if required.
Legacy Dispatch	<ul style="list-style-type: none"> Notify Mine Manager of event. Notify Legacy Safety Department. Maintain contact with on-scene observer. 	<ul style="list-style-type: none"> Notify Mine Manager of event. Notify Legacy Safety Department. Maintain contact with on-scene observer. 	<ul style="list-style-type: none"> Notify Mine Manager of event. Notify Legacy Safety Department. Maintain contact with on-scene observer.
Mine Manager	<ul style="list-style-type: none"> Enact MERP. Enact EMT and appoint Sector Chiefs, as required. Notify Director, Environmental Legacies and VP Environment. 	<ul style="list-style-type: none"> Enact MERP. Enact EMT and appoint Sector Chiefs. Notify Director, Environmental Legacies and VP Environment. Notify Teck Legal team if there are liability issues. Issue PR statements as required. 	<ul style="list-style-type: none"> Enact MERP. Enact EMT and appoint Sector Chiefs. Notify Director, Environmental Legacies and VP Environment. Notify Teck Legal team if there are liability issues. Issue PR statements as required.
EMT and Support Roles	<ul style="list-style-type: none"> Monitor event for direction of progress. Be prepared to escalate emergency to Medium Level, if required. 	<ul style="list-style-type: none"> Notify emergency personnel and have them begin site evacuation and access restriction, as required. Notify local emergency response agencies, as required, to assist with emergency management. Notify Yukon Emergency Measures, as required Notify Regulators, (Energy, Mines, and Resources, Environment Yukon, Highways and Public Works, Yukon OH&S, Natural Resources Canada) as required Notify Service Providers, (e.g., ATCO Electric) Notify federal regulators, (ECCC) as required Be prepared to escalate emergency to High Level, if required 	<ul style="list-style-type: none"> Notify emergency personnel and have them begin evacuation & access restriction. Notify local emergency response agencies, as required, to assist with emergency management. Notify Yukon Emergency Measures, as required Notify Regulators, (Energy, Mines, and Resources, Environment Yukon, Highways and Public Works, Yukon OH&S, Natural Resources Canada) as required Notify Service Providers, (e.g., ATCO Electric) Notify federal regulators, (ECCC) as required
VP Environment		<ul style="list-style-type: none"> Notify Teck Legal team if there are liability issues. Notify other Teck Corporate personnel as required. 	<ul style="list-style-type: none"> Notify Teck Legal team if there are liability issues. Notify other Teck Corporate personnel as required.

All copies of this document are uncontrolled when printed.

3.4 Step 4 – Emergency Response Actions

Emergencies on site will be managed using Incident Command System (ICS) structure.

Emergency Response Actions will include the following phases of:

Containment – The initial step to control an emergency: discovery and reporting of the problem; monitoring the situation; and early and immediate action.

Notification – Managers notify their own workers of the hazards and, if required, get them to safety and notify key personnel in order to mobilize the Emergency Response Procedures.

Mobilization – Takes effect when the Emergency Management Team has established control of the emergency operations. Outline of teams in place and their location. Occupation of emergency site and, if applicable, dispatch of Liaison to the Emergency Operations Centre.

Objectives	<ul style="list-style-type: none"> • Protect the health and safety of persons. • Protect the environment. • Secure business sites and facilities. • Safeguard and make available vital materials, supplies, and equipment to ensure the safety and recovery of records from predictable disasters. • Reduce the risk of further loss during an emergency. • Ensure the mine site ability to continue operating after an emergency. • Protect vital information and records.
INITIAL ACTIONS	
Containment Actions	<p>First on scene:</p> <ol style="list-style-type: none"> 1. Assume command of the emergency as the Incident Commander (IC) until relieved by a more qualified person. IC to use persons on scene as resources to complete following actions. 2. IC: Secure the scene and make safe (e.g., If there is a small fire that can be <u>safely</u> extinguished by fire extinguishers proceed to attempt to extinguish fire). 3. IC: Restrict access to event site (e.g., arrange for access gate guards, barricade roads). 4. IC: Arrange for evacuation of persons in immediate danger to the predetermined safe area (muster point), record all names of workers and cross reference with tally system. Determine whether any individuals are missing. If an individual is reported missing, perform a hasty search, if safe to do so. 5. IC: Initiate mitigation activities, based on incident action plan objectives, to attempt to gain control of the situation. 6. Shut off infrastructure that may be impacted, if safe to do so, or delegate another to do so. 7. Perform first aid within your scope of training to the injured, if safe to do so. 8. Arrange for transport of injured individuals to medical aid according to established first aid transport guidelines. 9. Freeze the scene. Preserve evidence, protect from elements (e.g., rain, snow), the use of tarps can be useful, taking photos can also preserve evidence. 10. In event of fatality: <ul style="list-style-type: none"> • limit access to essential personnel only. Do not move body, wait for RCMP to provide guidance. • begin notification without delay. <p style="color: red;"><i>Do not attempt to rescue persons from a hazardous area or to extinguish fire if unsafe to do so.</i></p>

INITIAL ACTIONS

<p>Notification Actions</p>	<ol style="list-style-type: none"> 1. IC: Initiate Emergency Response Team by calling 911 and requesting needed resources (police, ambulance). 2. IC: Assign someone familiar with the site to meet outside emergency services at the mine access point given to the 911 dispatcher, to escort them to the emergency scene. 3. IC: Notify Site Supervisors of emergency and associated hazards. Advise to have employees muster at safe locations as required. 4. IC: Notify Legacy Dispatch of emergency (1-250-427-6079). 5. Legacy Dispatch to notify Mine Manager and Legacy Safety (1-250-908-7058) of emergency. 6. Mine Manager or designate to determine level of emergency. See Error! Reference source not found. Assessment Guide. 7. Mine Manager or designate (EMT Leader) to notify Director, Environmental Legacies, VP Environment, regulatory agencies, and Teck Crisis Management team as required, based on severity of incident. <p><i>Contacts: Error! Reference source not found.</i></p>
<p>Mobilization Actions</p>	<ol style="list-style-type: none"> 8. If Incident Classification is Medium or High, establish a Department Operations Centre (DOC). Post notices to clearly mark DOC location. 9. Reference: Incident Command Emergency Response Checklist. 10. IC: Transfer command to Mine Manager or designate. 11. Operations Chief to establish Incident Command Post (ICP), staging area, and organize site. 12. Personnel who are deemed essential will be directed to report to the Department Operations Centre or Incident Command Post. 13. Form an Emergency Management Team from personnel on hand. Outline a plan of action. Assign qualified personnel to specific tasks. 14. Upon arrival of outside assistance (police, fire, ambulance), Unified Command (UC) may be established. <p><i>For Tailings Related Emergencies: See Appendix A and Mine OMS Manual for Tailings Facility Information and Specific Response Direction.</i></p>

3.5 Step 5 - Event Termination and Follow-Up

3.5.1 Event Termination

The emergency shall be terminated by the EMT. In the event of a High-Level emergency, in which case downstream effects will have occurred, the RCMP and any other emergency response agency or agencies shall be consulted, and the MERP will not be terminated until they are satisfied that there is no longer a risk to the public.

Once the EMT has determined the emergency has been brought under control and to a conclusion, Teck Legacy Properties can revert from an active emergency response situation to clean-up and remediation activities, and the implementation of the Return to Normal Conditions.

3.5.2 Event Termination Notification

The EMT shall notify the emergency response agencies, local municipalities, and Teck senior management that the emergency has passed. Once this notification has been provided, reverse notification shall be completed, and individuals shall update all notified personnel/agencies as listed in the Emergency Management Process Board.

A [TLP Emergency Event Termination Report](#) will be issued by Teck Legacy Properties.

3.5.3 Return to Normal Conditions – [Recovery Plan](#)

The Return to Normal Condition Plan shall be developed on a case-by-case basis. Actual events from the emergency will determine what measures are required, and what kind of timeline can be expected.

The event-specific Return to Normal Conditions Plan shall be the responsibility of the EMT. The Plan shall require the investigation and assessment of the extent of effects of the emergency.

3.5.4 Critical Incident Stress Management

Responding to and/or witnessing emergency incidents may potentially result in critical incident stress. Management is committed to providing support for individual employees experiencing critical incident stress. Teck Legacy Properties management will make available Post Incident Psychological Care where appropriate.

SECTION 4.0 ROLES AND RESPONSIBILITIES

4.1 Accountabilities, Roles, and Responsibilities

ICS Role	Name	Accountable for:
Incident Commander	Mine Manager or designate	<ul style="list-style-type: none"> Overall command of the emergency or incident. Safety Officer and Liaison Officer.
Emergency Operations Manager	EMT Member	<ul style="list-style-type: none"> Is the single point of contact with the On-scene Commander and the Emergency Response Team Passing information and requests from the On-scene Commander to the Incident Commander and the rest of Emergency Management Team Preparing, maintaining, and implementing the MERP
Emergency Planning Manager	EMT Member	<ul style="list-style-type: none"> Information Management (Info boards & logs) Needs log Short term planner (3-12 hours) Near term planner (next 24hrs - 3 days) Long term planner (3wks - VHO liaison)
Emergency Logistics Manager	EMT Member	<ul style="list-style-type: none"> Distribution Group, Supply Coordinator, IT & Communications, Medical, Fire Department
Emergency Liaison Manager	EMT Member	<ul style="list-style-type: none"> Legal Advice, Risk Group, Communities Liaison, Financial Control
Risk Management/Safety Officer	Health & Safety Team Member	<ul style="list-style-type: none"> Develop and recommend measures for ensuring personnel safety Assess and anticipate hazardous and unsafe situations
Security	EMT Member	<ul style="list-style-type: none"> Perimeter and site security integrity Vehicle Marshalling Point(s)
On-Scene Commander	EMT Member	<ul style="list-style-type: none"> Providing direction and leadership to the ERT Reports to Emergency Operations Manager
ERT Member	EMT Member	<ul style="list-style-type: none"> Mine rescue, firefighting, and emergency response
Medical Control Officer	EMT Member	<ul style="list-style-type: none"> Casualty Clearing Station, Onsite clinic, Ambulance Loading Point, Body Holding Area
Public Information Officer (PIO)	EMT Member	<ul style="list-style-type: none"> Liaising with the Vancouver Head Office Crisis Communications Team to get direction on providing support to the site and the emergency.
Subject Matter Expert	EMT Member	<ul style="list-style-type: none"> Covering major and severe risks present on site.
Communications Coordinator	EMT Member	<ul style="list-style-type: none"> Evaluate and maintain existing communication systems Develop alternative communications systems as required

All copies of this document are uncontrolled when printed.

Log Keeper	EMT Member	<ul style="list-style-type: none">• All incidents must be well documented -perhaps in tandem with planning. Scribes may be at the incident scene as well as in the Incident Command Centre.
------------	------------	-----------------------------------------------------------------------------------------------------------------------------------------------------------------------------------------------------------

4.2 EMT Organizational Chart

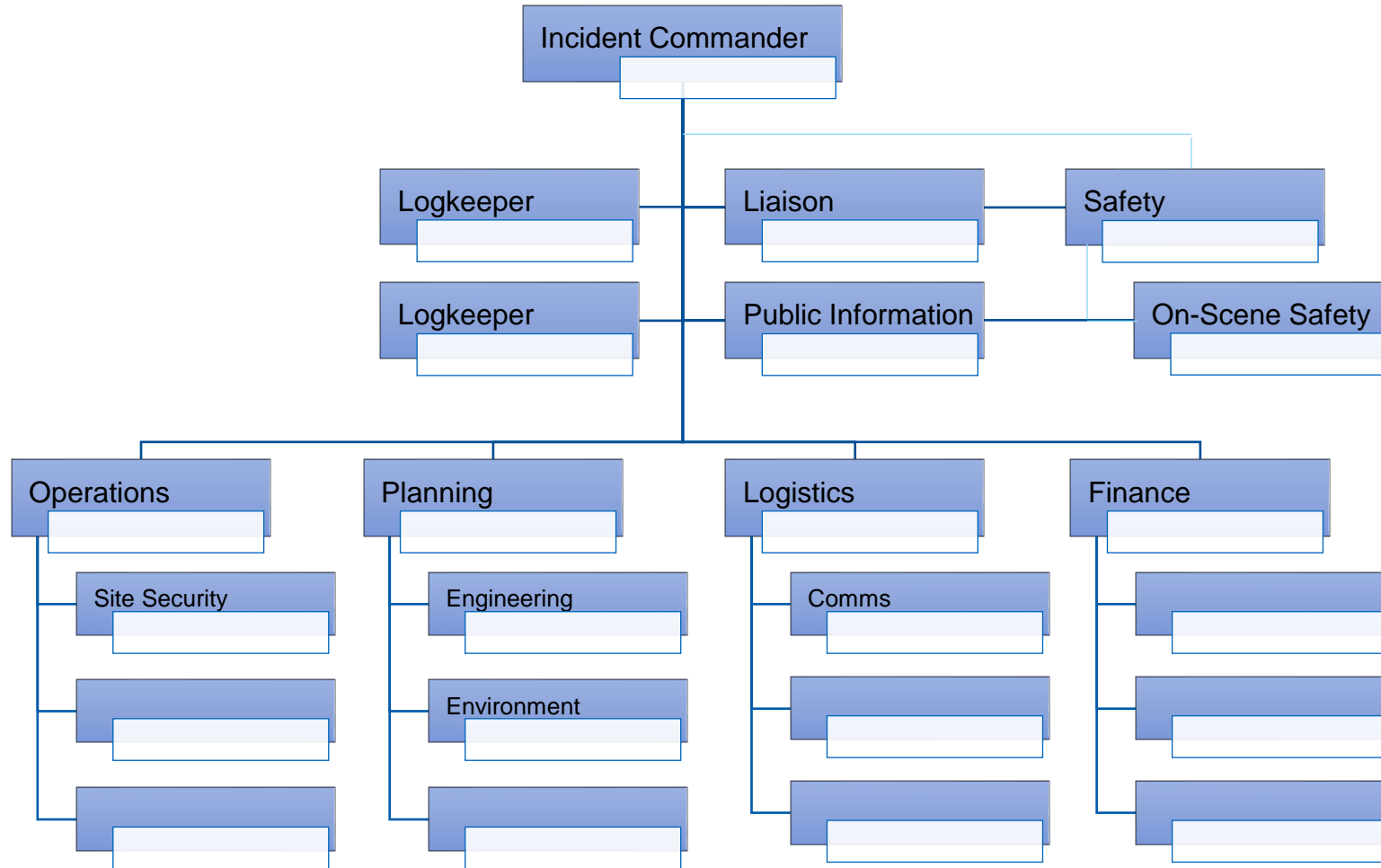

All copies of this document are uncontrolled when printed.

SECTION 5.0 USEFUL DOCUMENTS

5.1 Useful Documents

In addition to the documents listed below, reference materials are available in the following appendices:

Tailings and Water Retaining Structures – [Appendix A](#)

Commonly Used Documents – [Appendix B](#)

Maps – [Appendix C](#)

Evacuation Plan – [Appendix D](#)

Infrastructure at Risk – [Appendix E](#)

Other Available Resources – [Appendix F](#)

Public and Media Relations Management – [Appendix G](#)

5.1.1 Manuals

Manual Name	Purpose of Manual	Manual Document Number
Environmental Monitoring, Surveillance, and Reporting Plan	Outlines the strategy for site monitoring in the short- and long-term including water monitoring, physical monitoring, aquatic environmental monitoring, terrestrial and reclamation effectiveness	2017-06-28 Sä Dena Hes EMSRP Rev2.pdf
Operation Maintenance and Surveillance Manual (OMS)	Defines procedures for the safe operation, maintenance, and surveillance of the Sä Dena Hes Mine Tailings and Water Retaining Structures.	SDH-OMS-001
Post-Reclamation Adaptive Management Plan	A tool used to address uncertainty or conditions in water quality beyond those anticipated in post-reclamation.	Prepared By Alexco Environmental Group
Spill Contingency Plan	Outlines contingency measures and response strategies for spills of potentially hazardous substances, which may adversely affect the environment and/or human health and safety.	SDH-EP-001

All copies of this document are uncontrolled when printed.

5.1.2 Documents and Reports

Document Name	Purpose of Document	Document Number
Sä Dena Hes Mine Detailed Decommissioning & Reclamation Plan, August 2015 Update	Provides details on the closure and reclamation plans conducted at site.	(Teck, 2015)
Annual dam safety inspection report	Provides background, history, recent investigations	Most recent date
Annual Water License report	Provides annual environmental monitoring studies	Most recent date

5.2 Authority for Expenditure

Personnel are authorized to sign off on expenditures up to the limits set for their roles as part of normal business. Emergency expenditures will be authorized during incidents impacting business operations.

Finance will provide a person to the EMT whose task is to track expenditure and provide quick decisions on whether to exceed normal business expenditure and whether an Emergency Cost Code is required for the incident and recovery. An Emergency Cost Code can assist with tracking the financial impact related to the emergency event.

SECTION 6.0 CONTACTS

6.1 External Contacts

6.1.1 Emergency Services

Name	Position	Non-Emergency #	Emergency #
Watson Lake Ambulance	Ambulance	Office: 1-867-536-4444	1-867-536-4444
Air Ambulance – Alkan Air	Medical Evacuation	Office: 1-867-668-2107	1-867-536-5555 (Police) or 1-867-668-2107
Watson Lake Fire Department	Fire Chief – Charlie Crane	Office: 1-867-536-4755	1-867-536-2222
Watson Lake RCMP	RCMP	Office: 1-867-536-2677	1-867-536-5555 24-hour number
Yukon SAR	Jason Hudson - President	1-867-334-2518	1-867-667-5555
Watson Lake Community Hospital	Receiving Hospital	1-867-536-4444	1-867-536-4444
Poison Control Centre	Poison Control	1-800-567-8911	1-800-567-8911
Forest Fire Reporting	Forest Fire	1-888- 798-3473	1-888-798-3473
Yukon Wildfire	Main Office Yukon Duty Officer	1-867-456-3845 Office: 1-867-667-3128 Mobile: 1-867-332-1926	

All copies of this document are uncontrolled when printed.

Yukon Wildfire – Tintina Region	Cal Read – Regional Manager Duty Room	1-867-332-0013 1-867-536-2004 or 1-867-332-2005	
Yukon Wildland Fire – Watson Lake	Tyson Cole	1-867-536-4794	
Yukon First Nations Wildland Watson Lake	Aaron Johnson (AJ)	1-867-334-3330	
Avalanche Canada	Avalanche Forecasts Website: www.avalanche.ca	Phone: 1-250-837- 2141 Email: info@avalanche.ca	1-867-536-5555 (Police)
Yukon Emergency Measures Office			1-867-667-5220
Yukon Energy	Electrical Provider		1-800-676-2843
ATCO Electric Yukon	Electrical Emergencies	1-867-633-7000	1-800-661-0513
Director – Yukon OH&S		1-867-667-5450	
Yukon Worker’s Compensation Health & Safety Board	Worker Safety	1-867-667-5645	1-800-661-0443 or 1-867-667-5450
Transportation Safety Board	Transportation Safety	1-800-387-3557	

All copies of this document are uncontrolled when printed.

6.1.2 Local, Provincial, Territorial, and Federal Government

Agency	Contact #
YTG Department of Environment – Watson Lake Scott Allen	1-867-536-5081
Environment and Climate Change Canada	1-800-668-6767
Fisheries and Oceans Canada	1-867-393-6722
Yukon Water Board	1-867-456-3980
Crown-Indigenous Relations and Northern Affairs Canada	1-800-567-9604
Natural Resources Canada	1-867-667-3957
Transport Canada (Prairie and Northern Region)	1-888-463-0521
Yukon Environmental and Socio-Economic Assessment Board	1-867-668-6420
Yukon Conservation Officer Services TIPP – Turn In Poachers and Polluters	1-800-661-0525
Yukon Government - Energy, Mines and Resources	1-867-667-3130 1-867-667-3111
Energy, Mines, and Resources – Watson Lake Compliance Monitoring and Inspections	1-867-536-7335
Yukon Spill Line	1-867-667-7244

All copies of this document are uncontrolled when printed.

Yukon Highways and Public Works	1-800-661-0408 ext. 3732
---------------------------------	--------------------------

6.1.3 First Nations and Community

Name	Position	Contact #	Email
Liard First Nation	Band Administration Office	1-867-536-5200 TF: 1-866-736-2131	
Chad Hamer Graham Gifford	Trapper Cabin contacts	1-867-536-4501 1-438-793-9599 Coordinates: N 60.509917° W 128.863483° Elevation 4031 ft. The cabin is 40m off the roadside at 22km, visible from air and access road. Main access gate is at 24km.	chamer@northwestel.net

All copies of this document are uncontrolled when printed.

6.1.4 Service Providers

Name	Position	Contact #	Email
Castle Rock Enterprises	General Contractor – Whitehorse Equipment and materials	1-867-668-6188	office@castlerockent.com
Lyon Kechika Contracting – Derek Loots	Contractor - Equipment	1-250-775-0043 1-250-779-3010	
A Nice Motel	Hotel in Watson Lake	1-867-536-4639	info@anicermotel.com
Stampeder’s B&B Cabins	Watson Lake	1-867-536-2157	stampeders@northwestel.net
Horizon Helicopters	Whitehorse Cole Hodinski – Operations Manager	1-867-633-6044 1-867-335-2568	info@horizonhelicopters.ca cole@horizonhelicopters.ca
Canadian Helicopters Limited	Twin Engine Helicopter – Fort St. John	1-250-787-0432	
Yellowhead Helicopters Ltd. – Dease Lake	‘Emergency Use Only’ Helicopter Resource Call in order from top to bottom ->	Base #: 1-250-771-5164 Hangar #: 1-250-771-5911 Operations Support Centre #: 1-250-963-9884	osc@yhl.ca
Tundra Helicopters – Steve Harrison	Single Engine – requires variance to use	1-867-536-4644	
K&K Truck Rentals	Rental Agency - Whitehorse	1-867-456-2121	

All copies of this document are uncontrolled when printed.

Budget Car Rental	Whitehorse Airport	1-867-667-6200	
-------------------	--------------------	----------------	--

6.1.5 Consultants

Name	Position	Contact #	Email
Enerso Solutions	Environmental Consultant – Whitehorse	1-867-322-9152 Emilie cell: 1-514-249-3923	
Engineer of Record	Peter Mikes	Direct Office: 1-604-601-8489 SRK: 1-604-681-4196	1-250-420-7296 Email: pmikes@srk.com
Alternate Engineer of Record	Trevor Podaima	Direct Office: 1-306-955-4768 SRK: 1-306-955-4778	1-306-321-6694 Email: tpodaima@srk.com

All copies of this document are uncontrolled when printed.

6.3 Internal Contacts

6.3.1 Emergency Management Team Contacts

Name	Position	Work	Mobile	Email
Legacy Dispatch	After hours / weekend on-call Teck Legacy Properties	1-855-899-6857	1-250-427-6079	
Michelle Unger	Manager, Environmental Performance	1-250-427-8422	1-250-432-5264	Michelle.Unger@teck.com
Ray Proulx	Mine/Site Manager	1-250-242-6335	1-250-467-3194	Ray.Proulx@teck.com
Mark Slater	Manager, Geotechnical & Water	1-250-427-8434	1-250-433-7789	Mark.Slater@teck.com
Jeff Basarich	Project Manager; Sä Dena Hes Caretaker	1-780-618-4693	1-780-618-4693	Jeff.Basarich@teck.com
Morgan Lypka	RTFE	1-250-427-8114	1-250-425-5323	Morgan.Lypka@teck.com
Silawat Jeeravipoolvarn	Alternate RTFE	1-587-284-0319	1-587-284-0319	Silawat.Jeeravipoolvarn@teck.com
Katie Clark	Coordinator, Health & Safety	1-250-427-1087	1-250-427-1087	Katie.Clark@teck.com
Shari Lomon	Supervisor, Health, and Safety	1-250-427-8412	1-250-427-1061	Shari.Lomon@teck.com
John Adolphe	Emergency Response	1-250-427-9735	1-250-427-9735	John.Adolphe@teck.com

All copies of this document are uncontrolled when printed.

	Coordinator			
Wendy McBain	Environmental Coordinator	1-250-427-8436	1-236-505-0439	Wendy.McBain@teck.com

6.3.2 Crisis Management Team Contacts

Name	Position	Work	Mobile	Email
Bjorn Weeks	Director, Environmental Legacies, Environment - Acting	1-604-679-0079		Bjorn.Weeks@teck.com
Scott Maloney	VP Environment	1-604-699-4721	1-604-312-8680	Scott.Maloney@teck.com
Lauren Cook	Legal Counsel	1-604-695-5878	1-604-290-3574	Lauren.Cook@teck.com
Steve Hippiisley	Director, Risk, Security & Loss Control, Risk	1-604-699-5012	1-250-299-6458	Steve.Hippiisley@teck.com
Jeff Hanman	SVP, Sustainability & External Affairs	1-604-699-4338	1-604-354-5230	Jeff.Hanman@teck.com
Joshua Tepper	VP Health & Safety - Acting	1-604-695-5839	1-236-986-6569	Joshua.Tepper@teck.com
Nora Lozano	Director, Health & Safety (Alternate)	1-604-699-4103	1-778-554-4682	Nora.Lozano@teck.com

All copies of this document are uncontrolled when printed.

Sä Dena Hes Mine
Mine Emergency Response Plan

Chris Stannell	Public Relations Manager	1-604-699-4368	1-604-353-1609	Chris.Stannell@teck.com
Alana Duffy	Director, Communications	1-604-699-4547	1-604-347-9616	Alana.Duffy@teck.com

All copies of this document are uncontrolled when printed.

APPENDIX A
TAILINGS AND WATER RETAINING STRUCTURES

All copies of this document are uncontrolled when printed.

APPENDIX A TAILINGS FACILITIES

List of tailings storage facilities:

- Sä Dena Hes (SDH) Tailings Management Area (TMA)

A.1. Project Affected People (PAP) and Communities of Interest (COI)

There are no permanent dwellings in the vicinity of Sä Dena Hes that may be affected in the event of an embankment or TMA emergency at Sä Dena Hes, and should a failure occur, loss of life is unlikely other than through unforeseeable misadventure.

However, the following PAP and COIs located downstream of, or near, the Sä Dena Hes mine may be affected in the event of a tailings emergency:

- Residents of Watson Lake and the public who use areas close to the Sä Dena Hes mine for access and/or leisure activities (e.g., walking, cycling)
- Yukon Territory Emergency Measures
- Owners of hunter guiding, trapping, and fishing enterprises located near the Sä Dena Hes mine
- Indigenous Groups:
 - Liard First Nation

The above summary is not exhaustive or definitive and will continue to be reviewed and updated on an annual basis. Links to the current COI and PAP maps are provided below noting that these documents are considered “living” and will be revised as COI and PAP are identified and validated.

- [Sä Dena Hes COI Map](#)
- [Sä Dena Hes PAP Map](#)

Tailings Storage Facility Information Summary

Storage Facility	Embankment	Type	Approximate Embankment Length (m)	Approximate Maximum Height (m)	Volume Stored (Tailings and/or Water)
Sä Dena Hes TMA	North Dam	Lead/Zinc Tailings	260	15	700,000 tonnes Tailings No water stored

All copies of this document are uncontrolled when printed.

A.2. MERP Activation and Boundary between MERP and OMS

When an event occurs that is specified in the OMS TARP event driven criteria, an assessment must be made to determine whether to continue to follow the direction of the OMS and perform the associated tasks for all identified responsible persons or to activate the MERP and use the ICS management by objectives approach.

For all **developing** TARP event driven criteria incidents that do not meet the high-level TARP criteria, the associated TARP level should first be determined based on the initial situation report information. Low and medium-level TARP activations may not require MERP activation and management unless contributing situational factors are expected to escalate the event. Using the initial situation report information, complete a MERP activation assessment using the Incident Classification Assessment Guide to determine if there are potential outcomes identified which would necessitate activation of the MERP.

If a MERP activation is warranted, use the event driven action items provided in the low or medium-level TARP along with other situational information from the emergency scene as guidance for developing incident action plan objectives.

All high-level TARP activations should immediately activate the MERP. The initial situation report information should be assessed using the Incident Classification Assessment Guide to determine MERP level activation and to develop incident management objectives.

All event level assessments should be performed by the RTFE, the Site Manager, and the Site Health & Safety Coordinator in consultation with the Emergency Response Coordinator and Manager, Geotechnical & Water, if required.

A.3. Failure Modes and Risk Assessment

The RTFE is responsible for the validation and update the content of this section.

Tailings failure modes and risk assessment for the site have been completed and documented in two key documents including 1) Tailings Risk Register and 2) Catastrophic Credible Failure Scenario Assessment.

The potential failure modes for SDH TMA consist of:

- Overtopping, during freshet due to extreme snowpack/melt and ice blockage of the drainage channel to the south occurs during freshet that results in development of a pond that leads to overtopping
- Internal erosion through the foundation, which could occur during normal operations or during a flood or storm event.
- Slope instability, including from a seismic event, including but not limited to structural failure of embankment or foundation

External erosion through development of large gullies down the embankment slope or cutting of the toe. To supplement the risk register, Teck with support from EoR, conducted a credible catastrophic failure scenario assessment (CFSA). Teck's definition of a "catastrophic" failure is one with a risk to life safety or irreversible impact to a rare or valued ecosystem, social, or cultural heritage element – this definition is equivalent to "Severe" consequence in the risk matrix.

Of the above potential failure modes, the CFSA identified the following for the site:

- No severe downstream impacts were identified.
- Non-severe downstream impacts were identified for overtopping, internal erosion, slope instability and external erosion failure modes. The consequence of these failure scenarios include:
 - Health & Safety - Injury to personnel or public on dam crest or downstream of dam at time of failure (rare for anyone to be standing on or around the dam)
 - Environment - Reversible impact.
 - Communities - Potential inundation onto neighboring properties (first-nations land), perceived long-term impact.

An embankment breach inundation study has been completed for SDH TMA but is considered not required by the EoR at this time because there is no flow failure mode and no potential catastrophic impacts. The potential consequence of the catastrophic failure mode and the project affected people have been used in the development of the emergency response and actions in Section 3.4 to provide immediate response to save lives, supply humanitarian aid and minimize environmental harm in accordance with the Good Practice Guide (ICMM 2021).

Section A.4 provides some preventative and remedial measures to implement for the failure modes noted above and discussed below. These actions should only be performed under the direction of the Mine/Site Manager with the assistance of the Manager, Geotechnical and Water, site RTFE, Engineer of Record (EOR), associated consulting engineers, or other qualified professional engineers, along with Teck Legacy Site Safety Support.

Not all specific causes of embankment or tailings failure have been included here, only the most common types. These have been discussed in general terms only.

All copies of this document are uncontrolled when printed.

Overtopping

Overtopping failure is the uncontrolled flow of water over the embankment which can occur due to a severe storm (including wind) or flood event or “Fair Weather” event. At the SDH TMA, overtopping is only possible as a failure mode during extreme snowmelt leading to snow blockage of the TMA North Swale Drainage channel and creation of a temporary pond.

In the event of a major storm event, an inspection of the TMA shall be completed. Major storm event triggers are listed in the site TARP. Reoccurring seasonal (freshet) inspection triggers are also listed in the TARP.

Internal Erosion or Seepage Failure

Internal erosion occurs when the hydraulic forces exerted by seepage through the embankment, or its foundation are sufficient to cause the detachment of particles and to transport them out of the embankment (ICOLD 2015). Generally, clear seepage with low or no turbidity is not viewed as a serious problem, if there are adequate filters and drainage to prevent the transport of fill material.

The presence of new seepage can be identified in the winter months when new wet areas can be identified by the ice produced. In summer months, seepage can be identified through the accumulation of water and vegetation (such as bulrushes), and soft conditions on the downstream slope or near the toe. Identified seepage areas should be marked so that they can be monitored for changes in flow and size.

Turbid seepage should always be treated seriously, as it is an indication of internal erosion in the fill or foundation material. Internal erosion may lead to dam failure by progressive erosion (piping) if remedial actions are not taken immediately.

The following are types of seepage failure:

- **Piping Through the Embankment Fill:** When seepage occurs through the embankment fill. As material is eroded from the embankment, a void (referred to as a “pipe”) forms and may progressively work its way back until it connects to the pond, which eventually washes out the embankment.
- **Piping Through the Embankment Foundation:** If highly permeable cavities, bedrock faults or layers of gravel or coarse sand are present in the embankment foundation, it can result in heavy seepage through the embankment foundation. Concentrated seepage at high flow rates will erode the soil, resulting in increases in flow of water and soil. The embankment will settle, potentially leading to embankment failure.
- **Sloughing of the Downstream Slope:** Failure due to sloughing begins when the downstream toe becomes saturated and begins to erode, resulting in a small slump or slide on the embankment slope. This results in a steepened face, which will likely slump again to form an even more unstable surface. The process of saturation and slumping will continue until failure if remedial actions are not pursued.
- **Concentrated Leaks:** When water seeps along the interface between the embankment fill and a through-penetrating structure (i.e., a pipe through the embankment) and progressively erodes the embankment or foundation material, and eventually forms a “pipe” which connects to the pond.

Structural Failure – Slope Instability

Structural failures are typically a result of structural weaknesses, which are generally caused by improper maintenance, inadequate construction materials or unsound design.

Specific structural failure modes include the following:

- Embankment slide.
- Foundation slide.
- Faulty construction and poor maintenance.
- If material compaction was inadequate during construction, it may lead to embankment failure.

External Erosion

Earthen embankments are particularly susceptible to external erosion failure as the fill material used in construction can be eroded even at very low velocities. Failure due to external erosion from the action of water on the embankment may result from:

- erosion at the downstream toe (base) of the embankment, and/or flow velocities at the base of the embankment.
- erosion of the downstream face through the formation of erosion gullies. These generally form during heavy rainfall events (or overtopping from snowmelt), and formation of large erosion gullies could lead to failure. Properly maintained vegetation or other erosion control methods will help protect the downstream slope.

External erosion can be caused by one or a combination of the following factors:

- inadequate erosion protection
- poor maintenance
- overtopping

Earthquake – Slope Instability or Overtopping

Earthquakes can affect embankment stability through:

- the development of cracks within the structure.
- liquefaction of the tailings and/or foundation materials.

In the event of an earthquake event, an inspection of the embankment and TMA structures shall be completed. Earthquake triggers are listed in the site TARP.

A.4. Preventive & Remedial Actions

Though very unlikely, a failure of the TMA could impact the area downstream from the TMA. It is difficult to predict where an embankment breach would be initiated and precisely what corrective actions would be required. Nevertheless, to assist in dealing with emergency situations threatening the TMA, this section describes the resources available and potential courses of actions that could be taken promptly to avert an embankment breach.

The list below is not exhaustive, and any actions taken will be dependent on the emergency situation and the incident objectives determined by the Emergency Management Team (EMT) and implemented by the Incident Commander in the Incident Action Plan. The EMT will reference the OMS when determining the incident objectives and defining response actions based on the most current emergency situation report.

These actions are summarized as:

- lower pond water level.
- arrest or retard embankment internal erosion.
- arrest or retard embankment external erosion.
- build a toe buttress.

The sections below describe the necessary actions to be taken to mitigate potential impacts on the downstream area while the efforts to control the embankment incident are underway.

These actions should only be performed under the direction of the Mine/Site Manager with the assistance of the Manager, Geotechnical and Water, site RTFE, Engineer of Record (EOR), associated consulting engineers, or other qualified professional engineers, along with Teck Legacy Site Safety Support.

The following subsections provide additional information of the above preventive and remedial actions.

Lower Impoundment Pond Water Level

In the unlikely event of an embankment failure emergency, one of the main preventive measures is to limit water entering the facility and/or drawing down pond levels. This is applicable to embankment overtopping during a flood, loss of freeboard due to settlement, piping failure or other event which could lead to loss of containment. The following should be done:

- Re-direct water away from embankment crests by diverting upstream catchments and excavating temporary channels. Equipment will need to be sourced from preferred contractors.
- Check the TMA outlet and remove blockages if present.
- Install pumps near the TMA outlet to increase discharge capacity, sourced from preferred contractors, notify regulatory agencies, ensure due diligence is carried out and documented appropriately.

Arrest or Retard Internal Erosion

Once excess and/or murky seepage caused by internal erosion is detected, additional actions can be taken to arrest further development of the erosion, which could lead to piping failure of the embankment.

All copies of this document are uncontrolled when printed.

Follow the same steps as “Lower Impoundment Water Level”.

If sinkholes develop, they should be immediately filled with embankment fill materials compatible with the internal zoning of the embankment (generally sands and gravels). If the sinkholes are located upstream, efforts should be made to prevent pond water flowing into the sinkholes. If water levels cannot be lowered, then this could be accomplished by placing additional earthfill in the surrounding area to block any potential access of pond water to the sinkholes.

A weighted filter buttress berm should be placed over the exit area where excess and/or murky seepage is observed. The filter berm would allow free exit of seepage water without carrying away existing embankment fill and/or foundation materials. The filter berm is to be constructed of filter and drainage materials with progressively increasing particle size towards the berm outer surface.

If, in the seepage exit area, the initial flow velocity is too high for the placement of filter materials of appropriate size, materials of larger size and heavier weight may have to be placed first. As the seepage velocity is reduced by these oversized materials, the properly zoned filter berm could then be placed to arrest further development of internal erosion of the embankment.

The selection of materials and dimensions of the filter berm are to be defined by the Manager for Legacy Facilities in consultation with a qualified embankment engineer.

Digital photographs of seepage conditions prior to and during the construction of the filter berm are to be sent promptly to the qualified embankment engineer for on-going review.

Arrest or Retard External Erosion

If the embankment is experiencing external erosion, the following actions should be taken:

- Follow the same steps as “Lower Impoundment Water Level”.
- Place erosion protection (e.g., riprap, sandbags) along the affected areas where erosion is occurring.

In an event that an open channel begins to form on the embankment crest, granular materials should be used to plug the channel. Materials of sufficient size and weight can be moved into the breach from the alternate side of the channel. As the channel is gradually being closed, the materials used to plug the channel should increase in size and weight to cope with the increasing flow velocity. After the channel is completely closed, additional material should be placed upstream of the granular-fill plug to stop the seepage through the plug.

Build a Toe Buttress

If the embankment is showing signs of stability issues (e.g., tension cracks, slumping, scarps, toe bulging):

- Follow the same steps as “Lower Impoundment Water Level”.
- Construct a toe buttress along the affected area using granular fill (sand and gravel). Input will be required from a qualified geotechnical engineer on the size and extent of buttress required.

All copies of this document are uncontrolled when printed.

A.5. Links to Reference Documents for Tailings Related Emergencies

The following are links to related external manuals specific document sections used for the Tailings Related Emergencies. The links provide access to site specific information regarding the TSF and for specific emergency management prescriptive actions for tailings related emergencies identified in Section A.4.

- [OMS MANUAL SDH TMA](#)
- [TARP SDH TMA](#)

APPENDIX B
COMMONLY USED DOCUMENTS

All copies of this document are uncontrolled when printed.

B.1 TLP Emergency Event Termination Report

The TLP Emergency Event Termination Report is generated when a MERP activation incident has been deactivated. It provides details on the affected site, type of emergency, extent of damage or effects of the event on the site or downstream areas, and any outstanding items that may require attention after the termination.

[TLP Emergency Event Termination Report](#)

B.2 TLP Emergency Event Report

The TLP Emergency Event Report is generated to provide a description of the event and actions taken to bring the event to resolution and return to normal operating conditions. The report also contains any lessons learned that can be incorporated into any further MERP testing or MERP activations and forms part of the annual report of events.

[TLP Emergency Event Report](#)

B.3 TLP Emergency Event Recovery Plan

The TLP Emergency Event Recovery Plan is generated when an emergency event is being brought under control and a return to normal operating conditions is anticipated. It includes information on effects of the event and what will be required to return to normal conditions, including investigations, damage and site impact assessments, regulatory requirements, required remediation activities, and estimated recovery time. Post-event follow-up activities with individuals or agencies are also documented here.

[TLP Emergency Event Recovery Plan](#)

APPENDIX C
MAPS

C.1 SDH Mine Site Map



All copies of this document are uncontrolled when printed.

C.2 SDH Site Overview



All copies of this document are uncontrolled when printed.

C.3 SDH to Watson Lake Community Hospital Route

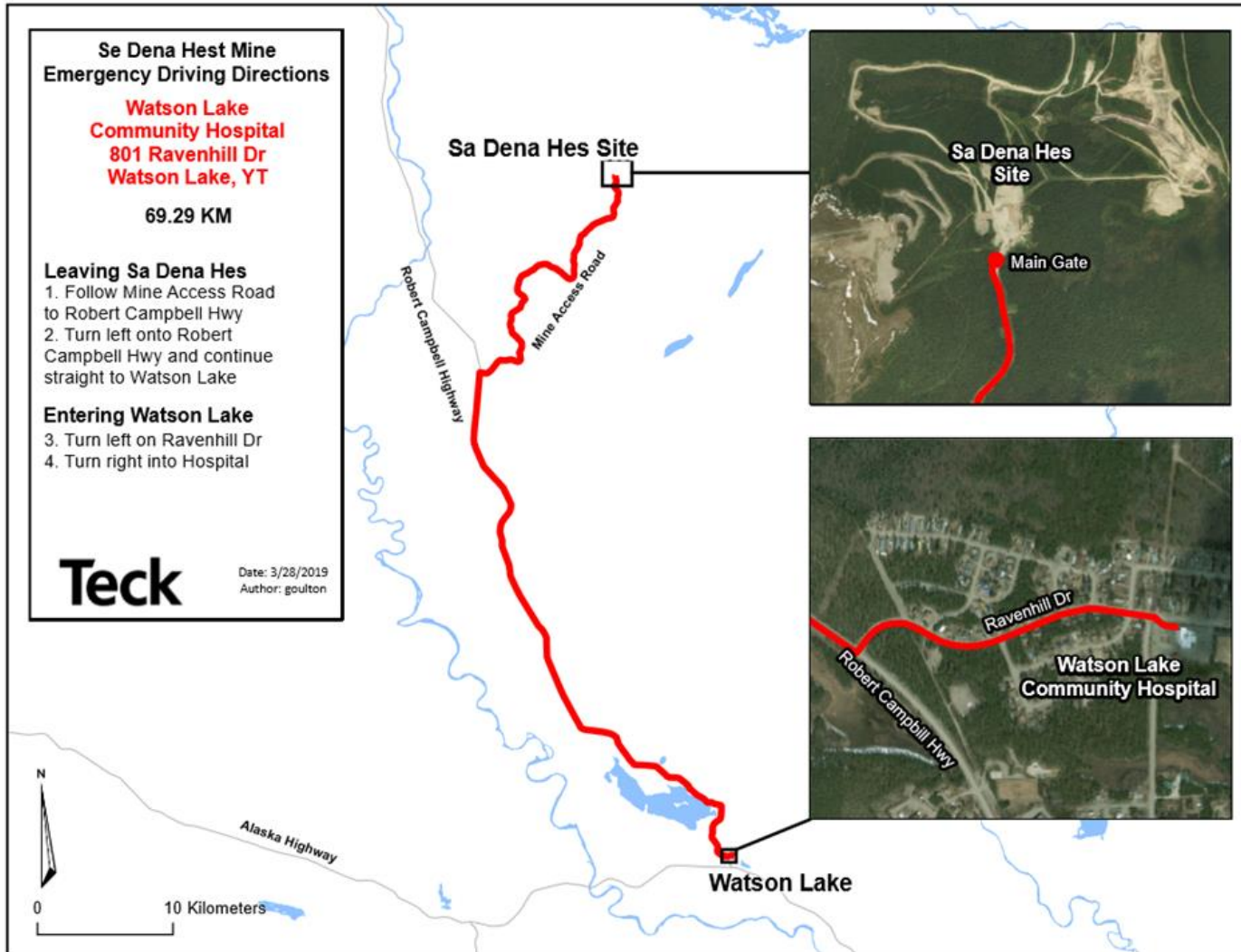

All copies of this document are uncontrolled when printed.

C.4 SDH Helipad Access Locations

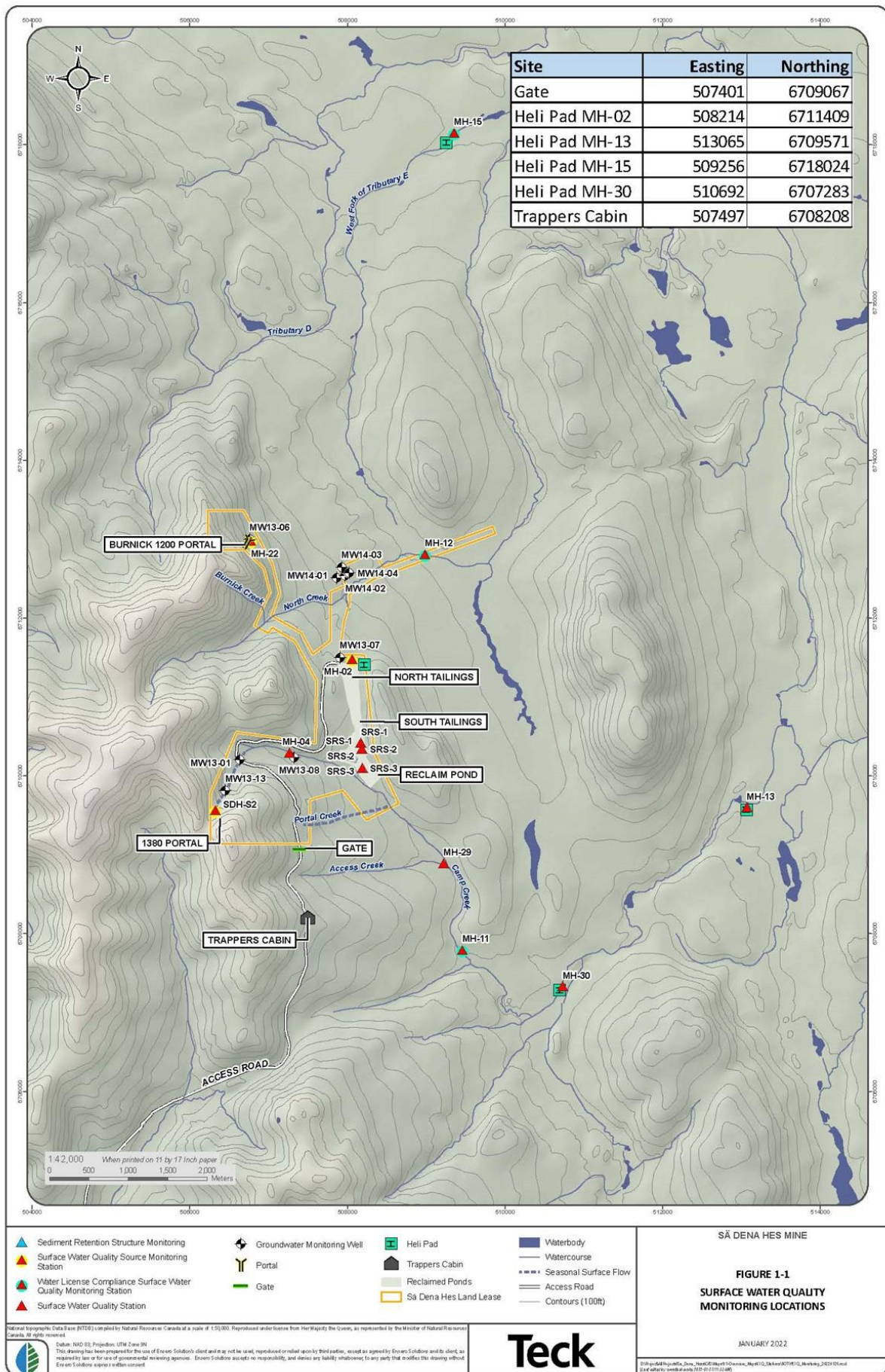

All copies of this document are uncontrolled when printed.

APPENDIX D
EVACUATION PLAN

All copies of this document are uncontrolled when printed.

SITE EVACUATION PLAN

If an Evacuation Order is in place, it means you are at risk and must leave immediately. Stop all current activities and proceed to designated muster areas (site access gates) and perform a personnel tally. Once all personnel are accounted for, proceed to evacuate the site along the designated routes. Follow all instructions provided by emergency response agencies, if provided.

D.1 SDH Evacuation Route to Watson Lake

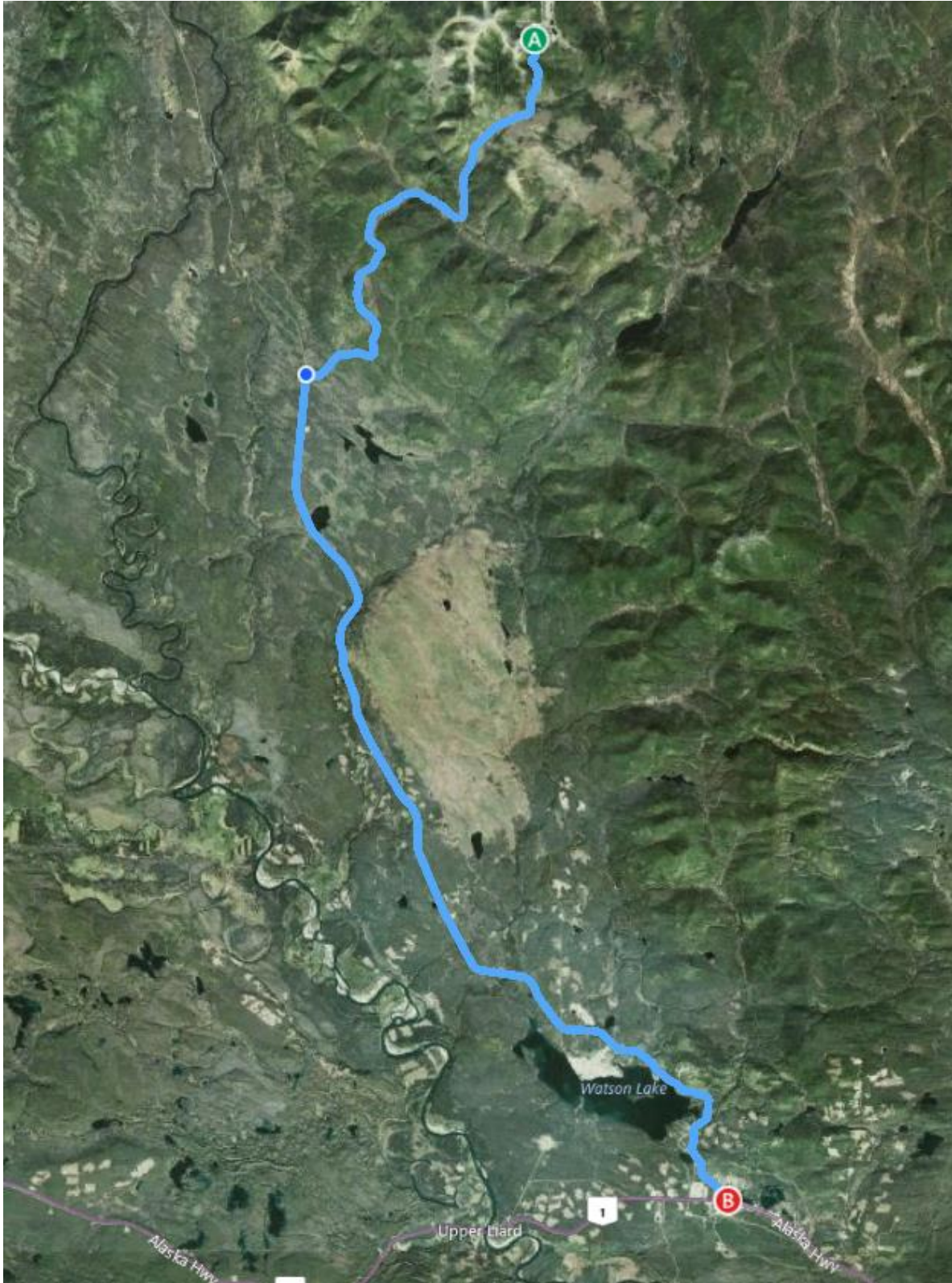

All copies of this document are uncontrolled when printed.

APPENDIX E
INFRASTRUCTURE AT RISK

All copies of this document are uncontrolled when printed.

E.1 Teck-Owned Infrastructure

There is no Teck-owned infrastructure on site outside of the Tailings Management Area.

E.2 External Agency-Owned Infrastructure

There is no external agency-owned infrastructure on site.

APPENDIX F
OTHER AVAILABLE RESOURCES

All copies of this document are uncontrolled when printed.

F.1 Other Available Resources

Other Equipment Inventory

There is no onsite rescue equipment. Teck employees and Contractors are instructed to bring to site at minimum the following:

- 1) Roadside Kit for each vehicle
- 2) Satellite phone or other means of communication (InReach) as there is no cell phone coverage on site
- 3) First Aid Supplies

As part of work preplanning (or a site visit) a risk assessment is performed to determine first aid training level and first aid response equipment required.

Air Operations Support

Helispots/Helipads	Easting	Northing
Gate	507401	6709067
MH-02	508214	6711409
MH-13	513065	6709571
MH-15	509256	6718024
MH-30	510692	6707283
Trapper Cabin	507497	6708208

APPENDIX G
PUBLIC AND MEDIA RELATIONS MANAGEMENT

All copies of this document are uncontrolled when printed.

G.1 Public and Media Relations

In the event of a serious incident that becomes of interest to the public or the media, all communications will be directed by the Teck Corporate Crisis Communication Team. A local Public Information Officer (PIO) will be established and communications regarding the incident will be provided by the Crisis Communication Team through the PIO.

All EMT members will follow the Crisis Communication procedures for Media Calls and On-Site Media Arrivals found below.

Incoming Media Calls during a Crisis

- Log all media calls using a [Media Log Sheet](#)
- Advise caller that someone will be back to them soon
- Forward digital media log sheets to Chris Stannell, chris.stannell@teck.com as soon as possible. Should a reporter press for information, please explain:

I am not the right person to speak to you about this. I will forward your contact information and the details of your inquiry to our Teck Corporate Affairs Team. Someone will be in touch with you shortly.

Should a reporter continue to press (aggressively) for information, please explain:

Again, I'm not the right person to speak to you about this. I will forward your contact and questions to our Teck Corporate Affairs Team as soon as we end the call.

Should a reporter use profanity or similar, please explain:

I have taken your information and the details of your question, which I will forward to our Teck Corporate Affairs Team I am ending the call now.

On-site Arrival of Reporter(s) and/or Camera Crew during a Crisis

- Politely ask for the reporter's/camera operator's business card
- Invite the reporter(s)/camera operator to be seated in the reception area, explaining that someone will be with them shortly

Should a reporter press for information, please explain:

I am not the right person to speak to you about this. Someone will be with you shortly. Thank you.

Should the camera operator start rolling, please ask him/her to take a seat in the reception area:

Please have a seat. Someone will be with you shortly. Thank you.

A few dos and don'ts

- Do remain calm and polite
- Do repeat the above scripted lines regardless of how many times or ways a reporter asks the question
- Do inform the Teck Corporate Crisis Communication Team as soon as possible of a media call or on-site arrival
- Do capture as much information as possible on the Media Log Sheet
- Do continue working calmly
- Don't be rude

All copies of this document are uncontrolled when printed.

Sä Dena Hes Mine Mine Emergency Response Plan

- Don't say 'no comment'
- Don't speculate
- Don't allow media to wander
- Don't put your hand up to cover the camera should it be rolling
- Don't cover your face should the camera be rolling