

REPORT ON

**CONSTRUCTION SURFACE WATER
MANAGEMENT PLAN
CARMACKS COPPER PROJECT
CARMACKS, YUKON**

Submitted to:

Western Copper Corporation
2050 – 111 West Georgia Street
Vancouver, BC
V6E 4M3

DISTRIBUTION:

- 1 Copy - Western Copper Corporation
- 1 Copy - M3 Engineering & Technology Corporation
- 2 Copies - Golder Associates Ltd.

June 24, 2008

07-1413-0077
Doc. No. 036 Rev. 1

EXECUTIVE SUMMARY

This report presents the Construction Surface Water Management Plan (CSWMP) for the Carmacks Copper Project (Project) construction phase. Stage I and Stage II represent initial phases of the construction. Since the project is being developed incrementally, Stage III and Stage IV are a transition from the construction phase into the operational phase of the Project. A separate SWMP has been developed for the permanent water management requirements for the operation phase of the Project and will be updated during the detailed design for the project and as Western Copper Corporation (WCC) moves into the actual operation of the mine.

The CSWMP describes a surface water management approach to collect, divert and treat water during the construction phase of the Project. This approach involves the use of temporary conveyance structures, permanent conveyance structures, as well as structural erosion and sediment control measures. The primary objective of the CSWMP is to minimize construction related impacts to surface water quantity and quality, while also facilitating construction works.

This CSWMP describes a preliminary site construction sequence, as well as the location and construction sequence of temporary and permanent water management measures that should be in place during construction for each of the major site facilities, and then into the operational phase for each facility. Details and construction guidelines for each of the proposed measures and erosion and sediment control structures are also presented in this report.

TABLE OF CONTENTS

<u>SECTION</u>	<u>PAGE</u>
EXECUTIVE SUMMARY	I
1.0 INTRODUCTION.....	1
2.0 SITE DESCRIPTION.....	2
3.0 PROJECT CONSTRUCTION SEQUENCE.....	3
4.0 CSWMP DESIGN BASIS	5
5.0 PROPOSED SURFACE WATER MANAGEMENT CONTROLS.....	6
5.1 Permanent Diversion Ditches	6
5.2 Temporary Diversion Ditches	6
5.3 Check Dams	6
5.4 Sediment Barrier - Brushwood Barriers and Sediment Fences.....	7
5.5 Additional Considerations	7
6.0 MONITORING	8
7.0 CLOSURE	9

LIST OF FIGURES

Figure 1 Location Plan

LIST OF DRAWING SHEETS

Sheet 1 Surface Water Management Plan Construction Stage I
Sheet 2 Surface Water Management Plan Construction Stage II
Sheet 3 Surface Water Management Plan Construction Stage III
Sheet 4 Surface Water Management Plan Construction Stage IV
Sheet 5 Surface Water Management Plan Construction Typical Details

LIST OF APPENDICES

Appendix I CSWMP Guidelines

1.0 INTRODUCTION

This report presents the Construction Surface Water Management Plan (CSWMP) for the Carmacks Copper Project (the Project) construction phase. The CSWMP describes the temporary conveyance structures, permanent conveyance structures, and erosion and sediment control measures to be used during construction of each of the major site facilities. The construction of the Project has been subdivided into four stages. Stage I and Stage II represent the initial phases of construction for the Project. Since the overall project will be incrementally developed, Stages III and Stages IV represent a transition from construction into operation. A separate Surface Water Management Plan (SWMP) has been developed for the permanent water management requirements for the operation phase of the Project and will be updated during the detailed design for the project and as Western Copper Corporation (WCC) moves into the actual operation of the mine.

Golder has relied on information obtained during Golder's 2007 field investigation program in addition to information obtained from previous work and Project information presented by Western Copper Corporation, and assumes there are no major omissions. Where available information is limited, or where additional detailed field investigation work may affect the design, attempts have been made to identify the interpretations and assumptions made.

The scope of this report is limited to the hydrotechnical aspects only, and does not include any specific provisions for the investigation, testing or assessment of the potential presence or impact of soil or groundwater contamination at the site, as this is beyond Golder's scope of work.

This report should be read in conjunction with the **“Important Information and Limitations of This Report”** which is appended following the text of the report. The reader's attention is specifically drawn to this information, as it is essential that it is followed for the proper use and interpretation of this report.

2.0 SITE DESCRIPTION

The Carmacks Copper Project consists of a proposed open pit copper mine with supporting infrastructure for extraction and processing of copper ore. The site is located in the Yukon Territory about 38 km northwest of the Village of Carmacks and 192 km north of Whitehorse (Figure 1).

The major infrastructure for the project includes the following:

- Open Pit Mine;
- Heap Leach Facility (HLF);
- Waste Rock Storage Area (WRSA);
- Crusher Plant;
- Process Plant;
- Events Pond;
- Truck Shop;
- Mine Haul Roads; and
- Camp Site.

3.0 PROJECT CONSTRUCTION SEQUENCE

The overall project construction sequence is described below and presented graphically on Sheets 1 to 4. This is considered a general sequence of construction that will be used to implement the CSWMP. Deviations from this sequence may occur during the construction program based on scheduling, material and equipment availabilities. The construction sequence has been divided into four main stages, which are described below:

STAGE I

The first stage of the construction phase includes construction of the Crusher Plant, Explosives Storage Area and Explosives Magazine, access road from the Crusher Plant to the Open Pit, the HLF and WRSA sediment ponds and the southern major diversion ditches around the HLF and WRSA. Diversion ditches around the Crusher Plant and downstream of the Pre-Production Open Pit will also be constructed.

Stockpile areas will be established north of the Open Pit, east of the HLF sediment pond, and near the WRSA sediment pond to contain any organic material or other materials stripped during development. Borrow pits will be established at the Plant Site and the WRSA and the Pre-Production Open Pit will be pre-stripped to obtain material for construction of the site facilities.

During Stage I construction, the Sediment Ponds will function as storage ponds whereby stored runoff will be used for moisture conditioning of soils and general site use such as dust suppression. Also, during Stage I, non-contact runoff from undisturbed areas will be conveyed in the diversion ditches around construction areas and then will be released into wide, natural overland flow areas. The overland flow areas will promote sheet flow, thereby reducing flow velocities and encouraging infiltration.

STAGE II

Once the HLF sediment pond and required segments of the surface water diversion ditches are constructed, the Plant Site, HLF Containment Berm, Events Pond, Truck Shop and Camp Site will be constructed. The access road between the WRSA and Open Pit will also be constructed.

Diversion ditches will be constructed to direct runoff around the areas to be stripped within the WRSA and HLF. The southern portion of the HLF will be stripped and graded and the eastern portion of the WRSA will be cleared and stripped of organics. Stockpiles will be developed to the south of the WRSA, and south of the Crusher Plant. Borrow Pits will be developed to the south of the Open Pit, west of the HLF, and west of the Truck Shop.

During Stage II water accumulated in either of the Sediment Ponds will be discharged to the adjacent natural water courses following removal of suspended particles, and/or reused during construction. Non-contact site runoff conveyed in the diversion ditches will also be discharged into adjacent waterways with implementation of best management practices to minimize suspended particles entering the water courses.

STAGE III

The third stage represents a transition from construction into operation, with incremental construction occurring. Stage three includes expansion of the HLF, Open Pit and WRSA and stripping the remaining footprint of the WRSA. The diversion ditches around the WRSA will be connected so that runoff drains to the WRSA sediment pond and diversion ditches around the HLF will be connected so that runoff drains to the HLF sediment pond. If necessary, a borrow pit and stockpile will be developed near the Explosives Storage Area.

STAGE IV

Stage four occurs during the operation of the mine and comprises expansion of the HLF and WRSA and Open Pit and completion of the remaining diversion ditches.

4.0 CSWMP DESIGN BASIS

The primary objective of the CSWMP is to minimize construction related impacts to surface water quantity and quality, while also facilitating construction works. Surface water management controls are to be implemented to divert overland flow around construction areas, reduce erosion and remove suspended sediments from surface water before it is released into wide, natural overland flow areas or back into natural watercourses.

This CSWMP considers construction areas to be disturbed non-industrial areas with a potential for inert sediment generation. No treatment or control measures have been included for any industrial chemicals or other contaminants. Additional controls or treatment facilities may be required for that purpose.

The CSWMP's for each of the major site facilities are presented on Sheets 1 to 5. The plans are based on four main principles for managing surface water during the construction phase of the project, as follows:

- *Construction of surface water controls* – includes construction of sediment ponds, diversion ditches, check dams and sediment barriers, and establishment of stockpile areas prior to any large scale land clearing or construction activity begins.
- *Diverting overland runoff from undisturbed areas* – includes interception and diversion of runoff from undisturbed areas around the construction sites to keep the construction areas dry and to minimize the potential for sediment transport into natural watercourses.
- *Control of sediment near the source* - the size and number of erosion and sediment controls is reduced by controlling sediment near the source.
- *Protect receiving waters downstream of the construction sites* – runoff from disturbed areas is collected and treated in Sediment Ponds to remove sediment prior to re-use at the site or release to natural watercourses.

5.0 PROPOSED SURFACE WATER MANAGEMENT CONTROLS

A number of temporary water management control structures have been proposed for the CSWMP. These structures correspond to standard Best Management Practices (BMPs) which have been adopted for the Project. Sheet 5 and Appendix I present construction guidelines for the proposed BMPs. To assure continued performance and functionality, all control structures should be inspected regularly, maintained and repaired, as required.

5.1 Permanent Diversion Ditches

Permanent diversion ditches are used to divert overland flow from undisturbed and disturbed areas and release it into wide, natural overland flow areas, natural watercourses or sediment ponds. The design of permanent diversion ditches and sediment ponds will be covered under a separate report.

5.2 Temporary Diversion Ditches

Temporary diversion ditches should be used to capture overland water flow from undisturbed areas and divert it around the construction sites and into wide, natural overland flow areas or natural watercourses downslope. These measures will not only facilitate construction, but will also limit the volume of water requiring treatment and the amount of sediment potentially eroded from disturbed areas.

Several diversion ditches are proposed in the CSWMP. Ditches with less than 2% grade are unlined but contain check dams to reduce velocities and settle sediment. Ditches that exceed 2% grade are lined with non woven geotextile over which rock riprap will be placed (refer to Sheet 5).

5.3 Check Dams

Check dams are small temporary structures installed within a ditch to reduce flow velocity, reducing potential to cause erosion in the channel and allowing sediment to settle.

For this project, it is recommended that check dams are installed along the sections of the diversion ditches that are not lined with rock riprap. As illustrated in Sheet 5, check dams should be spaced at approximately 40 m intervals.

5.4 Sediment Barrier - Brushwood Barriers and Sediment Fences

These are temporary filters made of brushwood available at the site wrapped in geotextile or sediment fences that provide a physical barrier to sediment and help reduce the velocity of overland surface water runoff. Sediment fences are linear filter barriers installed to prevent or minimize transport of sediment in overland runoff.

Brushwood barriers or alternatively sediment fences can be used downslope of disturbed areas and around stockpiles to capture sediment.

5.5 Additional Considerations

In addition to the control structures described above, the following BMPs should be applied to the construction sites:

- Maintain as much of the existing vegetation as possible. Limiting the disturbance is recognized as the single, most effective method of reducing erosion.
- Limit the length and steepness of excavated slopes by benching.
- Surface compaction reduces the potential for suspending sediment. Roughening the surface of disturbed areas serves to increase infiltration into the ground surface during rainfall events. Roughening the surface of a disturbed area can be accomplished by tracking the area with heavy equipment, such as a bulldozer, or track mounted excavator.
- Prevent tracking of sediments off-site by implementing dust control measures for roads.

It is recommended that surface water management monitoring be implemented during the construction phase, with regular inspections and water sampling if required, to assure the performance of the control measures meets the water quality standards for the Project.

6.0 MONITORING

All water management structures should be monitored weekly and after each rain event for maintenance purposes. Accumulated sediment should be cleaned out and buried and away from drainage flow paths and natural watercourses. Additional erosion and sediment controls may need to be implemented as required.

7.0 CLOSURE

We trust that the information contained in this report meets your present requirements. Please contact us if you have any questions or concerns regarding the above.

Yours very truly,

GOLDER ASSOCIATES LTD.

ORIGINAL SIGNED BY

Wade Ludlow, B.Eng.
Water Resources Group

ORIGINAL SIGNED BY

Fiona Esford, P.Eng. (BC)
Project Manager

Reviewed by

ORIGINAL SIGNED BY

Peter W. Morgan, P.Eng. (BC)
Associate, Water Resources Group

WL/FCE/PWM/kt

Attachments

O:\Final\2007\1413\07-1413-0077\doc 036 Rpt-0624_08 WCC-Construction Surface Water Management Plan.doc

IMPORTANT INFORMATION AND LIMITATIONS OF THIS REPORT

Standard of Care: Golder Associates Ltd. (Golder) has prepared this report in a manner consistent with that level of care and skill ordinarily exercised by members of the engineering and science professions currently practising under similar conditions in the jurisdiction in which the services are provided, subject to the time limits and physical constraints applicable to this report. No other warranty, expressed or implied is made.

Basis and Use of the Report: This report has been prepared for the specific site, design objective, development and purpose described to Golder by the Client. The factual data, interpretations and recommendations pertain to a specific project as described in this report and are not applicable to any other project or site location. Any change of site conditions, purpose, development plans or if the project is not initiated within eighteen months of the date of the report may alter the validity of the report. Golder can not be responsible for use of this report, or portions thereof, unless Golder is requested to review and, if necessary, revise the report.

The information, recommendations and opinions expressed in this report are for the sole benefit of the Client. No other party may use or rely on this report or any portion thereof without Golder's express written consent. If the report was prepared to be included for a specific permit application process, then upon the reasonable request of the client, Golder may authorize in writing the use of this report by the regulatory agency as an Approved User for the specific and identified purpose of the applicable permit review process. Any other use of this report by others is prohibited and is without responsibility to Golder. The report, all plans, data, drawings and other documents as well as all electronic media prepared by Golder are considered its professional work product and shall remain the copyright property of Golder, who authorizes only the Client and Approved Users to make copies of the report, but only in such quantities as are reasonably necessary for the use of the report by those parties. The Client and Approved Users may not give, lend, sell, or otherwise make available the report or any portion thereof to any other party without the express written permission of Golder. The Client acknowledges that electronic media is susceptible to unauthorized modification, deterioration and incompatibility and therefore the Client can not rely upon the electronic media versions of Golder's report or other work products.

The report is of a summary nature and is not intended to stand alone without reference to the instructions given to Golder by the Client, communications between Golder and the Client, and to any other reports prepared by Golder for the Client relative to the specific site described in the report. In order to properly understand the suggestions, recommendations and opinions expressed in this report, reference must be made to the whole of the report. Golder can not be responsible for use of portions of the report without reference to the entire report.

Unless otherwise stated, the suggestions, recommendations and opinions given in this report are intended only for the guidance of the Client in the design of the specific project. The extent and detail of investigations, including the number of test holes, necessary to determine all of the relevant conditions which may affect construction costs would normally be greater than has been carried out for design purposes. Contractors bidding on, or undertaking the work, should rely on their own investigations, as well as their own interpretations of the factual data presented in the report, as to how subsurface conditions may affect their work, including but not limited to proposed construction techniques, schedule, safety and equipment capabilities.

Soil, Rock and Groundwater Conditions: Classification and identification of soils, rocks, and geologic units have been based on commonly accepted methods employed in the practice of geotechnical engineering and related disciplines. Classification and identification of the type and condition of these materials or units involves judgment, and boundaries between different soil, rock or geologic types or units may be transitional rather than abrupt. Accordingly, Golder does not warrant or guarantee the exactness of the descriptions.

Special risks occur whenever engineering or related disciplines are applied to identify subsurface conditions and even a comprehensive investigation, sampling and testing program may fail to detect all or certain subsurface conditions. The environmental, geologic, geotechnical, geochemical and hydrogeologic conditions that Golder interprets to exist between and beyond sampling points may differ from those that actually exist. In addition to soil variability, fill of variable physical and chemical composition can be present over portions of the site or on adjacent properties. **The professional services retained for this project include only the geotechnical aspects of the subsurface conditions at the site, unless otherwise specifically stated and identified in the report.** The presence or implication(s) of possible surface and/or subsurface contamination resulting from previous activities or uses of the site and/or resulting from the introduction onto the site of materials from off-site sources are outside the terms of reference for this project and have not been investigated or addressed.

Soil and groundwater conditions shown in the factual data and described in the report are the observed conditions at the time of their determination or measurement. Unless otherwise noted, those conditions form the basis of the recommendations in the report. Groundwater conditions may vary between and beyond reported locations and can be affected by annual, seasonal and meteorological conditions. The condition of the soil, rock and groundwater may be significantly altered by construction activities (traffic, excavation, groundwater level lowering, pile driving, blasting, etc.) on the site or on adjacent sites. Excavation may expose the soils to changes due to wetting, drying or frost. Unless otherwise indicated the soil must be protected from these changes during construction.

Sample Disposal: Golder will dispose of all uncontaminated soil and/or rock samples 90 days following issue of this report or, upon written request of the Client, will store uncontaminated samples and materials at the Client's expense. In the event that actual contaminated soils, fills or groundwater are encountered or are inferred to be present, all contaminated samples shall remain the property and responsibility of the Client for proper disposal.

Follow-Up and Construction Services: All details of the design were not known at the time of submission of Golder's report. Golder should be retained to review the final design, project plans and documents prior to construction, to confirm that they are consistent with the intent of Golder's report.

During construction, Golder should be retained to perform sufficient and timely observations of encountered conditions to confirm and document that the subsurface conditions do not materially differ from those interpreted conditions considered in the preparation of Golder's report and to confirm and document that construction activities do not adversely affect the suggestions, recommendations and opinions contained in Golder's report. Adequate field review, observation and testing during construction are necessary for Golder to be able to provide letters of assurance, in accordance with the requirements of many regulatory authorities. In cases where this recommendation is not followed, Golder's responsibility is limited to interpreting accurately the information encountered at the borehole locations, at the time of their initial determination or measurement during the preparation of the Report.

Changed Conditions and Drainage: Where conditions encountered at the site differ significantly from those anticipated in this report, either due to natural variability of subsurface conditions or construction activities, it is a condition of this report that Golder be notified of any changes and be provided with an opportunity to review or revise the recommendations within this report. Recognition of changed soil and rock conditions requires experience and it is recommended that Golder be employed to visit the site with sufficient frequency to detect if conditions have changed significantly.

Drainage of subsurface water is commonly required either for temporary or permanent installations for the project. Improper design or construction of drainage or dewatering can have serious consequences. Golder takes no responsibility for the effects of drainage unless specifically involved in the detailed design and construction monitoring of the system.

N:\Active\Year 2007\1413\07-1413-0077 (Carmacks Copper)\DRAFTING\CAD\Surface Water Management Plan 28 Feb 08\ Drawing file: K7100-09.dwg Jun 23, 2008 - 5:11pm



PROJECT				WESTERN COPPER CORPORATION CARMACKS COPPER PROJECT YUKON TERRITORY			
TITLE				LOCATION PLAN			
PROJECT No.		07-1413-077		FILE No.		K7100-09.DWG	
DESIGN				SCALE	AS SHOWN	REV.	0
CADD	S.S.S.	FEB-29-08		FIGURE 1			
CHECK							
REVIEW							

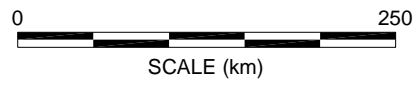

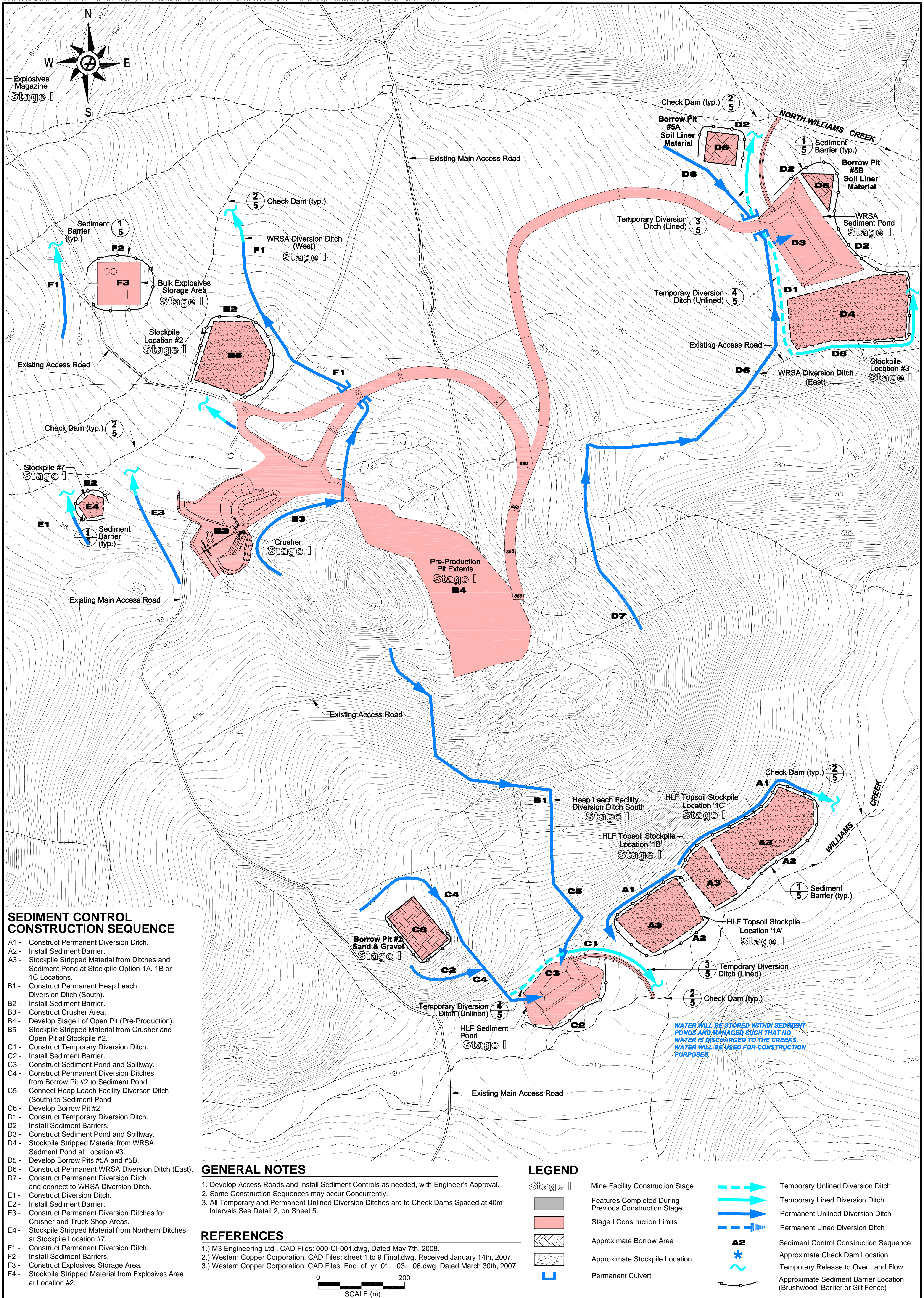

SEDIMENT CONTROL CONSTRUCTION SEQUENCE

- A1 - Construct Permanent Diversion Ditch.
- A2 - Install Sediment Barrier.
- A3 - Stockpile Stripped Material from Ditches and Sediment Pond at Stockpile Option 1A, 1B or 1C Locations.
- B1 - Construct Permanent Heap Leach Diversion Ditch (South).
- B2 - Install Sediment Barrier.
- B3 - Construct Crusher Area.
- B4 - Develop Stage I of Open Pit (Pre-Production).
- B5 - Stockpile Stripped Material from Crusher and Open Pit at Stockpile #2.
- C1 - Construct Temporary Diversion Ditch.
- C2 - Install Sediment Barrier.
- C3 - Construct Sediment Pond and Spillway.
- C4 - Construct Permanent Diversion Ditches from Borrow Pit #2 to Sediment Pond.
- C5 - Connect Heap Leach Facility Diversion Ditch (South) to Sediment Pond
- D1 - Develop Borrow Pit #2
- D2 - Construct Temporary Diversion Ditch.
- D3 - Install Sediment Barriers.
- D4 - Construct Sediment Pond and Spillway.
- D5 - Stockpile Stripped Material from WRSA Sediment Pond at Location #3.
- D6 - Develop Borrow Pits #5A and #5B.
- D7 - Construct Permanent WRSA Diversion Ditch (East).
- E1 - Construct Permanent Diversion Ditch and connect to WRSA Diversion Ditch.
- E2 - Construct Diversion Ditch.
- E3 - Install Sediment Barrier.
- E4 - Construct Permanent Diversion Ditches for Crusher and Truck Shop Areas.
- F1 - Stockpile Stripped Material from Northern Ditches at Stockpile Location #7.
- F2 - Construct Permanent Diversion Ditch.
- F3 - Install Sediment Barriers.
- F4 - Construct Explosives Storage Area.
- F5 - Stockpile Stripped Material from Explosives Area at Location #2.

GENERAL NOTES

1. Develop Access Roads and Install Sediment Controls as needed, with Engineer's Approval.
2. Some Construction Sequences may occur Concurrently.
3. All Temporary and Permanent Unlined Diversion Ditches are to Check Dams Spaced at 40m Intervals See Detail 2, on Sheet 5.

REFERENCES

- 1.) M3 Engineering Ltd., CAD Files: 000-CI-001.dwg, Dated May 7th, 2008.
- 2.) Western Copper Corporation, CAD Files: sheet 1 to 9 Final.dwg, Received January 14th, 2007.
- 3.) Western Copper Corporation, CAD Files: End_of_yr_01, _03, _06.dwg, Dated March 30th, 2007.

LEGEND

<p>Stage I</p> <ul style="list-style-type: none"> Features Completed During Previous Construction Stage Stage I Construction Limits Approximate Borrow Area Approximate Stockpile Location Permanent Culvert 	<ul style="list-style-type: none"> Temporary Unlined Diversion Ditch Temporary Lined Diversion Ditch Permanent Unlined Diversion Ditch Permanent Lined Diversion Ditch Sediment Control Construction Sequence Approximate Check Dam Location Temporary Release to Over Land Flow Approximate Sediment Barrier Location (Brushwood Barrier or Silt Fence)
--	---

SHEET 1	<p>PROJECT</p> <p style="text-align: center;">WESTERN COPPER CORPORATION CARMACKS COPPER PROJECT YUKON TERRITORY</p>	<p>DRAFT</p> <p>NOT FOR CONSTRUCTION</p> <p>For Discussion Purposes Only</p>	<p>SCALE (m)</p> <p>0 200</p>	<p>DATE</p> <p>DES</p> <p>REVISION DESCRIPTION</p> <p>CADD</p> <p>CHK</p> <p>RVV</p>	<p>23/06/08 A.I./W.L. ISSUED WITH REVISED REPORT S.S.S.</p> <p>21/05/08 A.I./W.L. ISSUED FOR CLIENT REVIEW S.S.S.</p> <p>29/02/08 W.L. ISSUED WITH REPORT S.S.S.</p>	<p>Goldier Associates</p> <p>Abbotsford, BC</p>
----------------	---	---	-------------------------------	--	--	---

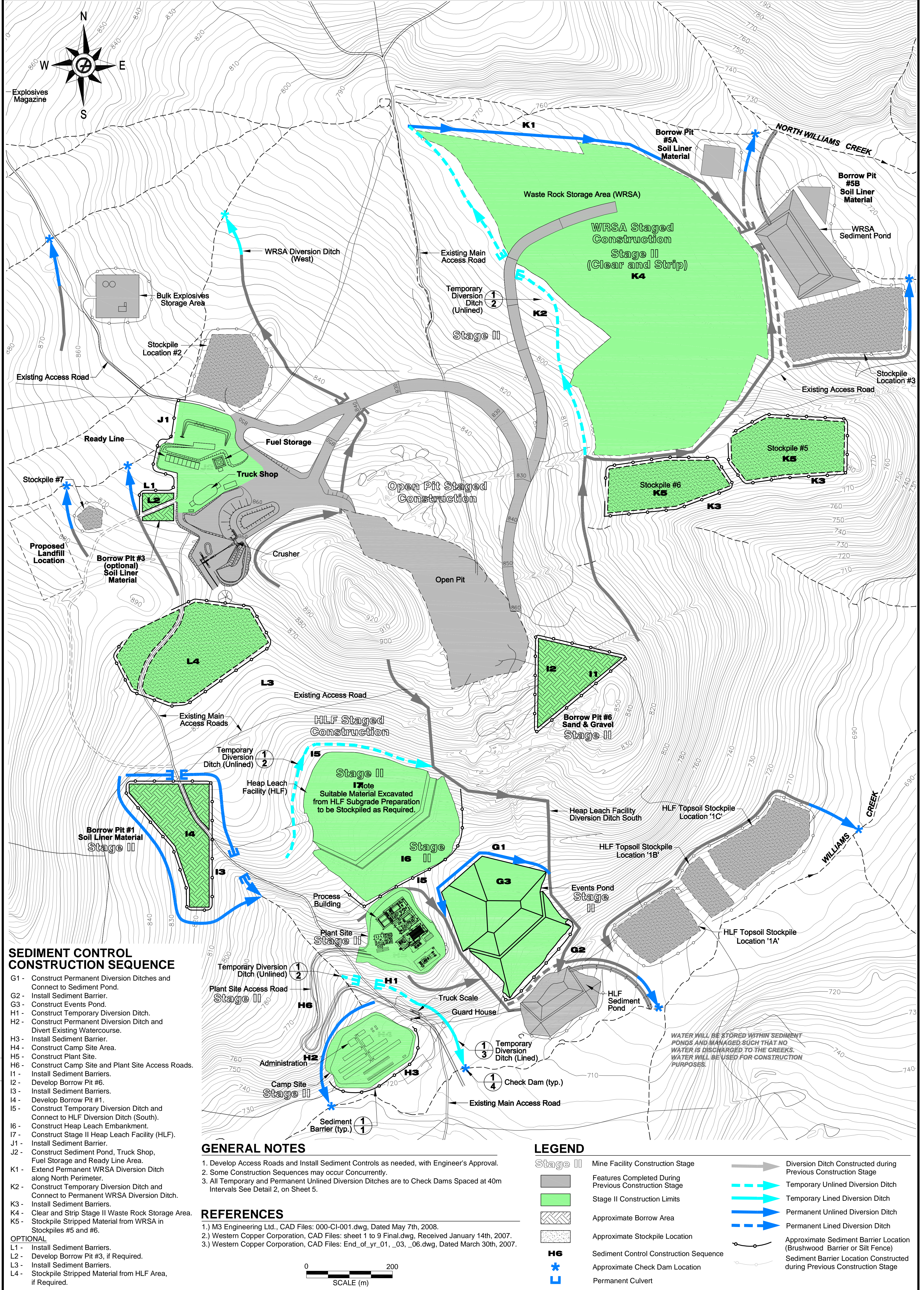

SEDIMENT CONTROL CONSTRUCTION SEQUENCE

- G1 - Construct Permanent Diversion Ditches and Connect to Sediment Pond.
 - G2 - Install Sediment Barrier.
 - G3 - Construct Events Pond.
 - H1 - Construct Temporary Diversion Ditch.
 - H2 - Construct Permanent Diversion Ditch and Divert Existing Watercourse.
 - H3 - Install Sediment Barrier.
 - H4 - Construct Camp Site Area.
 - H5 - Construct Plant Site.
 - H6 - Construct Camp Site and Plant Site Access Roads.
 - I1 - Install Sediment Barriers.
 - I2 - Develop Borrow Pit #6.
 - I3 - Install Sediment Barriers.
 - I4 - Develop Borrow Pit #1.
 - I5 - Construct Temporary Diversion Ditch and Connect to HLF Diversion Ditch (South).
 - I6 - Construct Heap Leach Embankment.
 - I7 - Construct Stage II Heap Leach Facility (HLF).
 - J1 - Install Sediment Barrier.
 - J2 - Construct Sediment Pond, Truck Shop, Fuel Storage and Ready Line Area.
 - K1 - Extend Permanent WRSA Diversion Ditch along North Perimeter.
 - K2 - Construct Temporary Diversion Ditch and Connect to Permanent WRSA Diversion Ditch.
 - K3 - Install Sediment Barriers.
 - K4 - Clear and Strip Stage II Waste Rock Storage Area.
 - K5 - Stockpile Stripped Material from WRSA in Stockpiles #5 and #6.
- OPTIONAL**
- L1 - Install Sediment Barriers.
 - L2 - Develop Borrow Pit #3, if Required.
 - L3 - Install Sediment Barriers.
 - L4 - Stockpile Stripped Material from HLF Area, if Required.

GENERAL NOTES

1. Develop Access Roads and Install Sediment Controls as needed, with Engineer's Approval.
2. Some Construction Sequences may occur Concurrently.
3. All Temporary and Permanent Unlined Diversion Ditches are to Check Dams Spaced at 40m Intervals See Detail 2, on Sheet 5.

REFERENCES

- 1.) M3 Engineering Ltd., CAD Files: 000-CI-001.dwg, Dated May 7th, 2008.
- 2.) Western Copper Corporation, CAD Files: sheet 1 to 9 Final.dwg, Received January 14th, 2007.
- 3.) Western Copper Corporation, CAD Files: End_of_yr_01_03_06.dwg, Dated March 30th, 2007.

LEGEND

- Stage II** Mine Facility Construction Stage
- Features Completed During Previous Construction Stage
- Stage II Construction Limits
- Approximate Borrow Area
- Approximate Stockpile Location
- H6** Sediment Control Construction Sequence
- Approximate Check Dam Location
- Permanent Culvert
- Diversion Ditch Constructed during Previous Construction Stage
- Temporary Unlined Diversion Ditch
- Temporary Lined Diversion Ditch
- Permanent Unlined Diversion Ditch
- Permanent Lined Diversion Ditch
- Approximate Sediment Barrier Location (Brushwood Barrier or Silt Fence)
- Sediment Barrier Location Constructed during Previous Construction Stage

SHEET 2	<p>SURFACE WATER MANAGEMENT PLAN CONSTRUCTION STAGE II</p>	<p>WESTERN COPPER CORPORATION CARMACKS COPPER PROJECT YUKON TERRITORY</p>	<p>DRAFT NOT FOR CONSTRUCTION For Discussion Purposes Only</p>	<table border="1" style="width: 100%; border-collapse: collapse;"> <thead> <tr> <th>REV</th> <th>DATE</th> <th>DES</th> <th>REVISION DESCRIPTION</th> <th>CADD</th> <th>CHK</th> <th>RWV</th> </tr> </thead> <tbody> <tr> <td>23/06/08</td> <td>A.I./W.L.</td> <td></td> <td>ISSUED WITH REVISED REPORT</td> <td></td> <td></td> <td>S.S.S.</td> </tr> <tr> <td>21/05/08</td> <td>A.I./W.L.</td> <td></td> <td>ISSUED FOR CLIENT REVIEW</td> <td></td> <td></td> <td>S.S.S.</td> </tr> <tr> <td>29/02/08</td> <td>W.L.</td> <td></td> <td>ISSUED WITH REPORT</td> <td></td> <td></td> <td>S.S.S.</td> </tr> </tbody> </table>	REV	DATE	DES	REVISION DESCRIPTION	CADD	CHK	RWV	23/06/08	A.I./W.L.		ISSUED WITH REVISED REPORT			S.S.S.	21/05/08	A.I./W.L.		ISSUED FOR CLIENT REVIEW			S.S.S.	29/02/08	W.L.		ISSUED WITH REPORT			S.S.S.
REV	DATE	DES	REVISION DESCRIPTION	CADD	CHK	RWV																										
23/06/08	A.I./W.L.		ISSUED WITH REVISED REPORT			S.S.S.																										
21/05/08	A.I./W.L.		ISSUED FOR CLIENT REVIEW			S.S.S.																										
29/02/08	W.L.		ISSUED WITH REPORT			S.S.S.																										



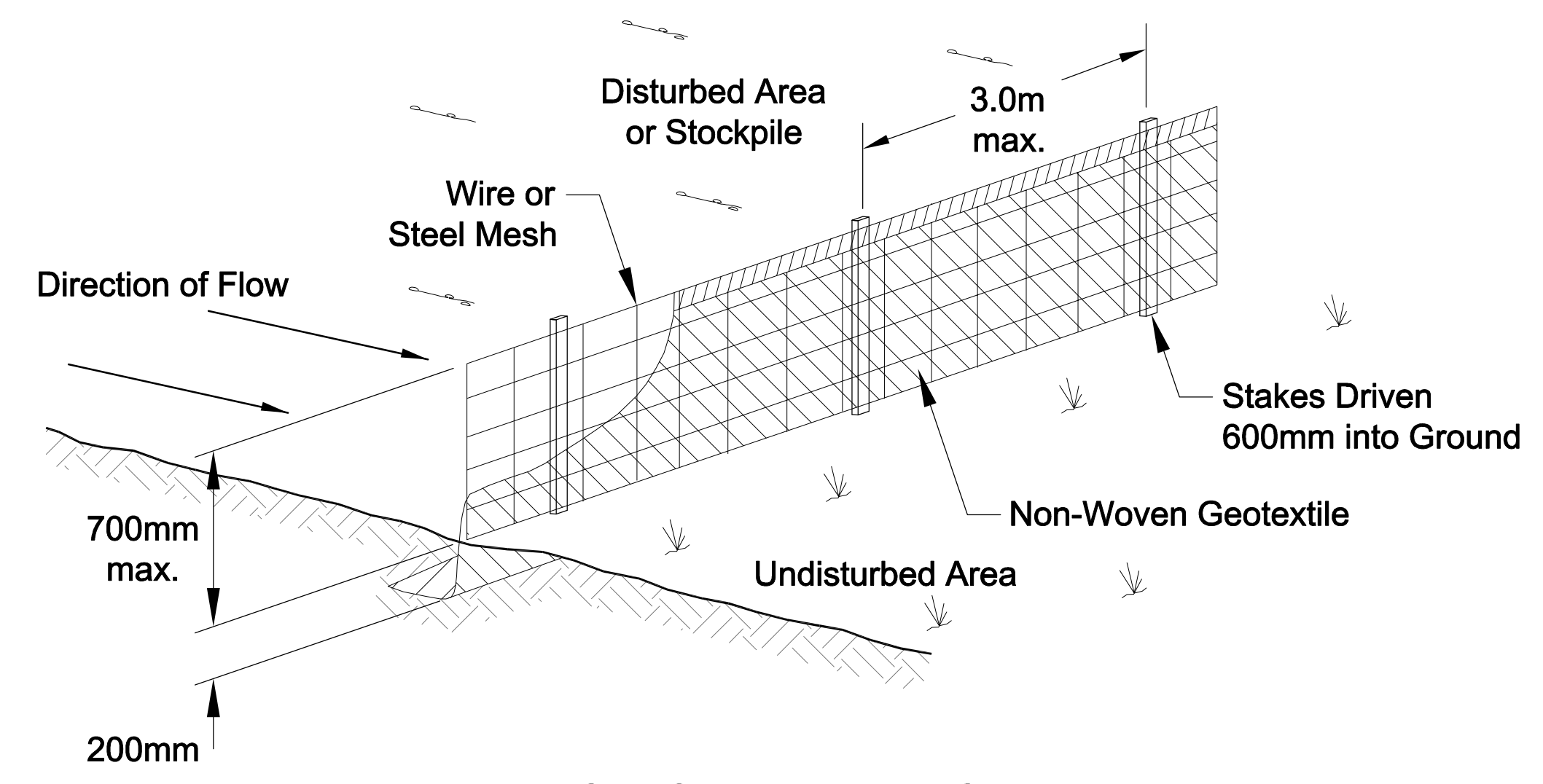

TYPICAL SEDIMENT FENCE

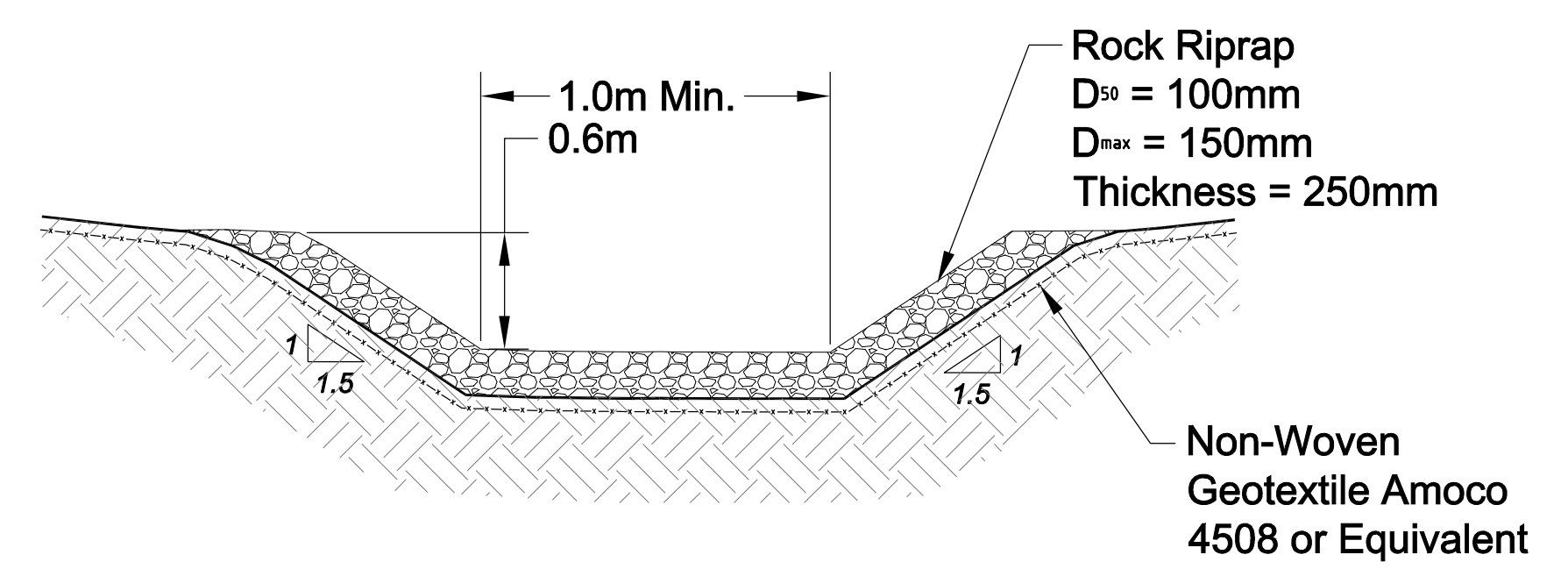

3 TYPICAL TEMPORARY DIVERSION DITCH (LINED)
Not to Scale

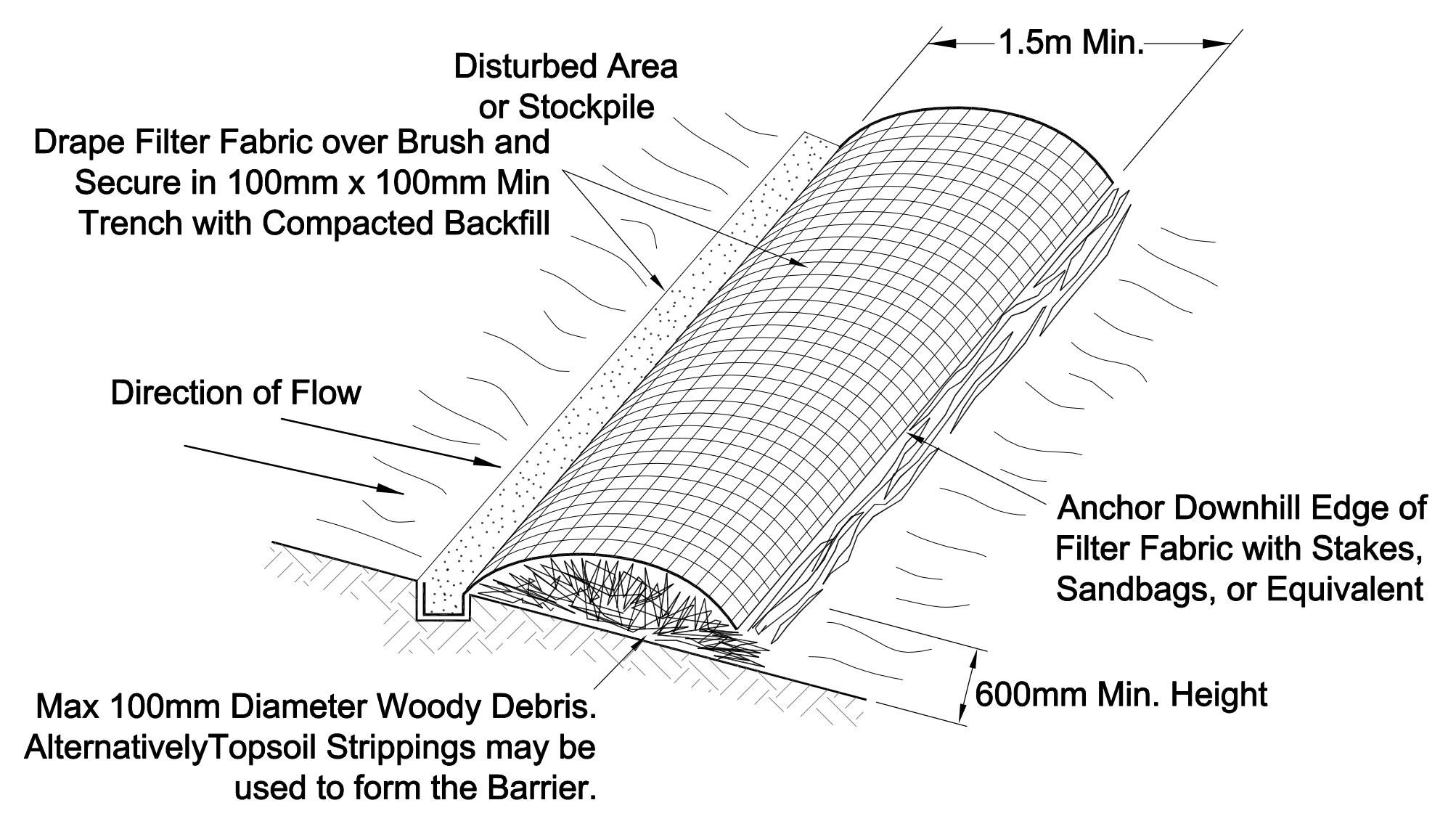

TYPICAL BRUSHWOOD BARRIER

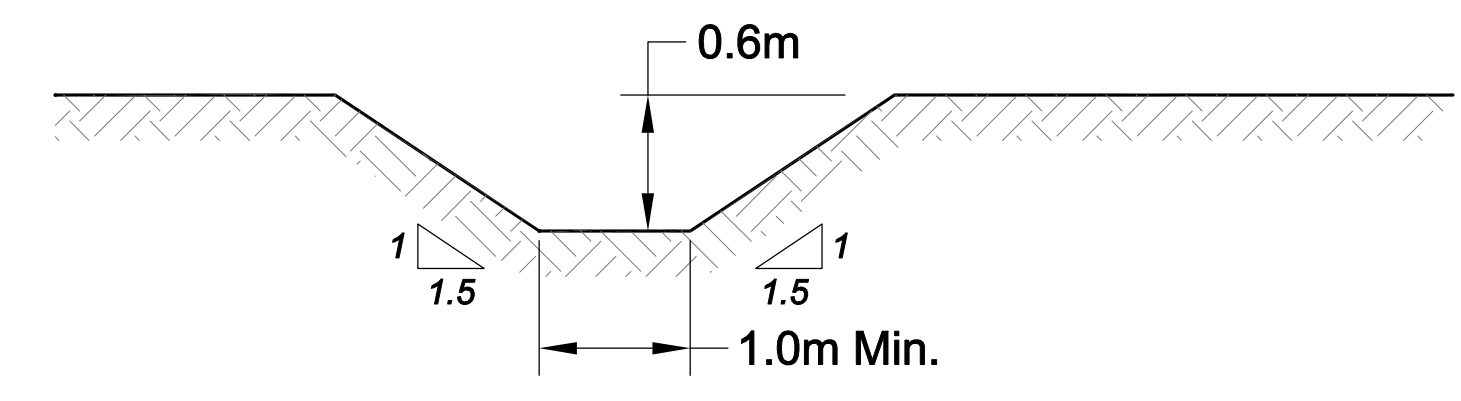

OPTION A

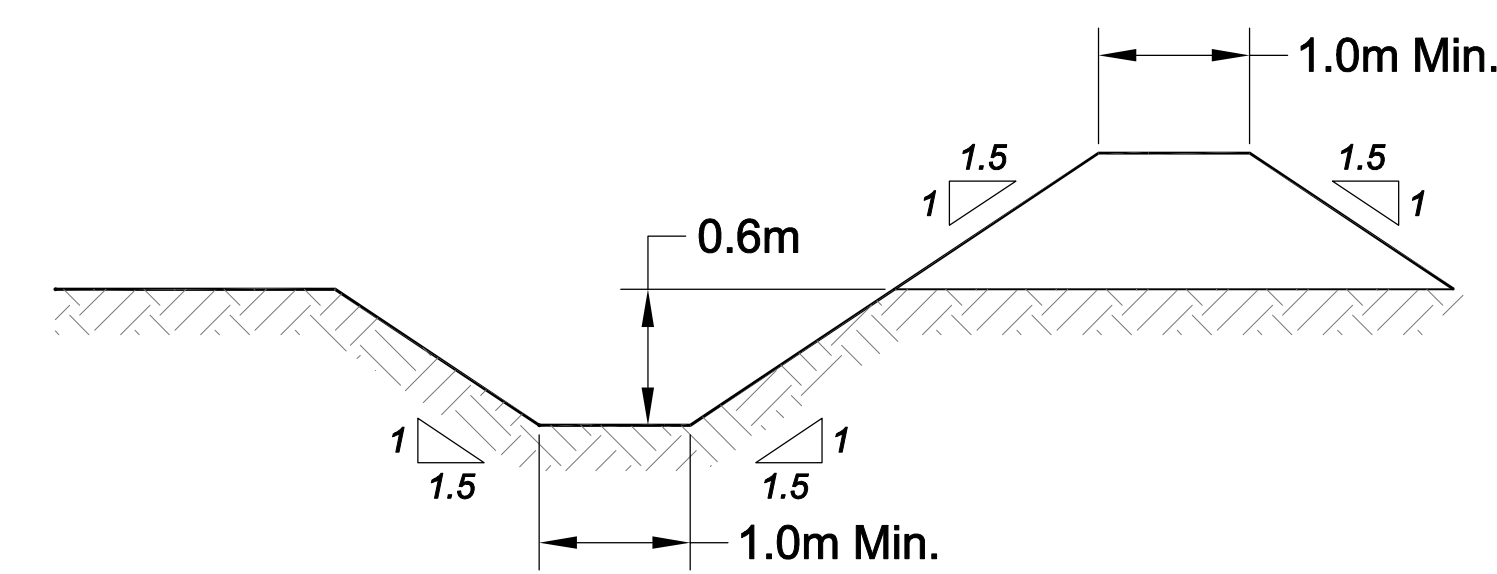

OPTION B

4 TYPICAL TEMPORARY DIVERSION DITCH (UNLINED)
Not to Scale

1 TYPICAL SEDIMENT BARRIERS
Not to Scale

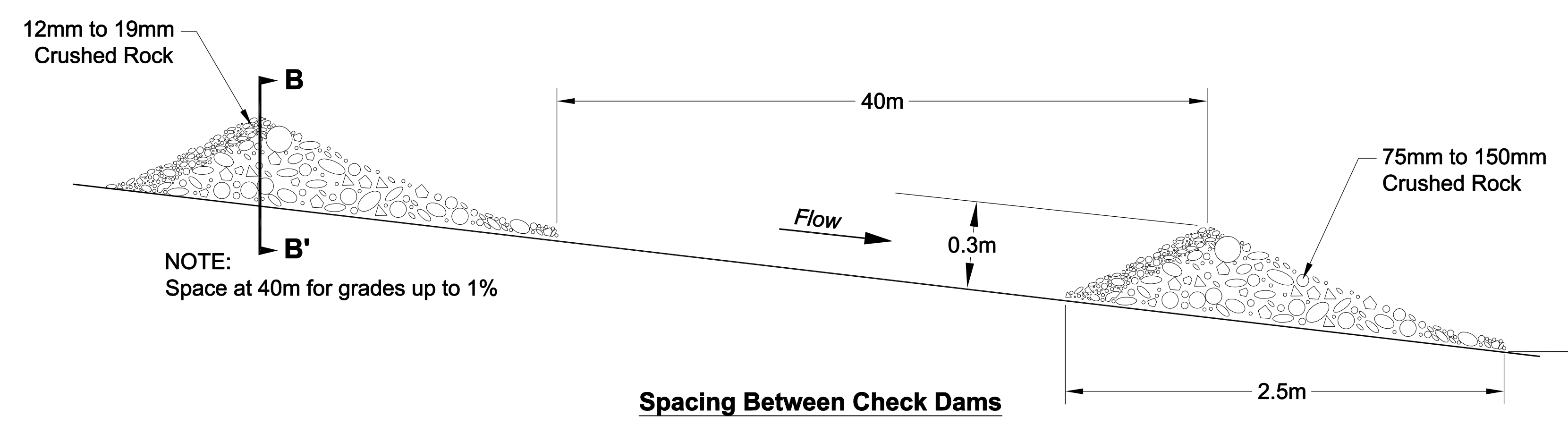

2 TYPICAL CHECK DAM
Not to Scale

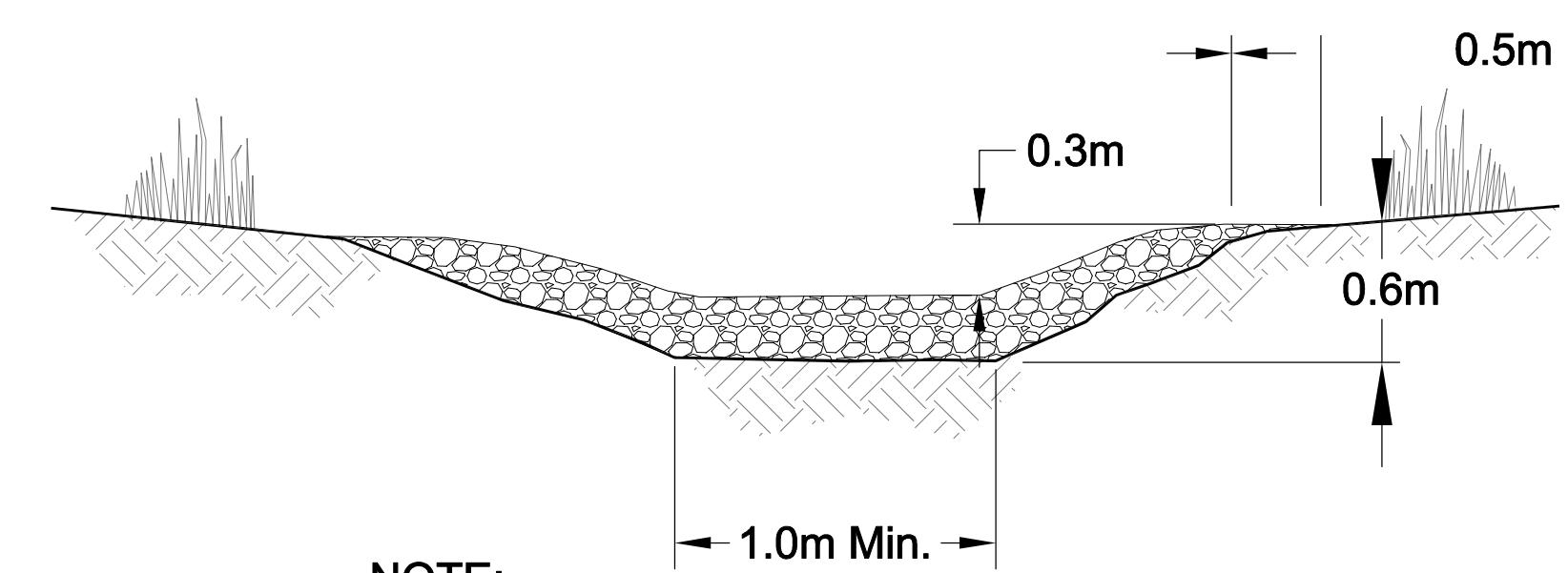

NOTE:
Key rock into channel banks and extend it beyond the abutments a minimum of 0.5m to prevent flow around dam.

Section B-B'

REV	DATE	DES	ISSUED WITH REPORT	S.S.S.	CHK	ROW
1	29/02/08					

PROJECT
WESTERN COPPER CORPORATION
CARMACKS COPPER PROJECT
YUKON TERRITORY

TITLE
SURFACE WATER MANAGEMENT PLAN CONSTRUCTION TYPICAL DETAILS

PROJECT No.	07-1413-0077
PHASE	7100 TASK 1000
FILE No.	P7100-05.DWG
REV.	0 SCALE AS SHOWN
DESIGN	W.L. 29/02/08
CADD	S.S.S. 29/02/08
CHECK	
REVIEW	

I:\Projects\2007\1413\07-1413-0077 - Carmacks Copper\05-Construction\Water Management\Plan 29_02_08.dwg
 29/02/08 10:58:11 AM
 S.S.S.

APPENDIX I
CSWMP GUIDELINES

BRUSH BARRIER AND BRUSH MATTING MATERIALS

Lay temporary brush barrier, constructed from residue from site clearing, at perimeter of site to intercept and retain sediment in runoff water from disturbed areas. Install overlapping layers of brush barrier using material with stems less than 100 mm in diameter.

Wrap woven geotextile filter fabric over the brush and clearing material and place ends in trenches located along the length of the barrier.

Backfill trench with compacted soil to anchor fabric.

SEDIMENT FENCE

- Construct sediment fence from woven geotextile filter fabric attached to the upstream face of steel posts 1.5 m long. Install posts to depth of 600 mm in ground at 3 m centres. When fabric is used without the wire support fence, post spacing shall not exceed 1.5 m.
- When standard-strength filter fabric is used, a wire mesh support fence shall be fastened securely to the upslope side of the posts using heavy duty wire staples at least 25 mm long or tie wires.
- The standard-strength filter fabric shall be stapled or wired to the fence, and 0.75 m of the fabric shall extend into the trench. The fabric shall not extend more than 1 m above the original ground surface. When extra-strength filter fabric and closer post spacing are used, the wire mesh support fence may be eliminated. The filter fabric is then stapled or wired directly to the posts.
- Bury lower edge of filter fabric in a trench excavated a minimum of 300 mm wide and 300 mm deep on upstream side of posts. Backfill trench and compact soil. Overlap edges of fabric lengthways by 0.5 m. Turn the ends of the fence uphill. The height of a sediment fence shall not exceed 1 m.
- Sediment fences should be placed on contour to be most effective.

CHECK DAMS

- Check dams are intended to reduce gully erosion. Check dams reduce flow velocities, trap and store larger-sized sediment and provide stabilized drops.
- They are keyed into the bank and bottom sufficiently.
- They are maintained so that one failed check dam does not jeopardize the entire series.