



# **EAGLE GOLD PROJECT**

## **WATER MANAGEMENT PLAN**

*Version 2020-01*

**JANUARY 2020**

**THIS PAGE INTENTIONALLY LEFT BLANK**

---

## TABLE OF CONTENTS

<b>1</b>	<b>Introduction .....</b>	<b>1</b>
1.1	Project Location and Background .....	1
1.2	Project Schedule .....	4
1.3	Definitions .....	4
1.4	Scope of Plan .....	4
<b>2</b>	<b>Water Management Planning.....</b>	<b>6</b>
2.1	Objectives .....	6
2.2	Strategies .....	6
2.3	Execution Strategy .....	7
2.3.1	Roles and Responsibilities .....	7
2.3.2	Responsibility, Accountability, Consultation and Information.....	9
2.3.3	Engineers of Record.....	13
<b>3</b>	<b>Environmental Conditions .....</b>	<b>14</b>
3.1	Regional Setting.....	14
3.2	Climate .....	14
3.2.1	Project Site .....	14
3.2.2	Temperature .....	15
3.2.3	Potential Evaporation .....	15
3.2.4	Precipitation.....	17
3.2.5	Snow Accumulation and Snowmelt.....	18
3.2.6	Extreme Rainfall/Snowmelt .....	19
3.3	Physiography .....	23
3.4	Surface Water .....	23
3.4.1	Streamflow.....	23
3.4.2	Surface Water Quality .....	25
3.4.2.1	Dublin Gulch Drainage .....	25
3.4.2.2	Eagle Creek Drainage.....	27
3.4.2.3	Haggart Creek Drainage .....	28
3.5	Groundwater .....	33
3.5.1	Hydrogeologic Setting .....	33
3.5.2	Groundwater Occurrence .....	33
3.5.3	Groundwater Flow .....	34
3.5.4	Surface Water - Groundwater Connectivity.....	34
3.5.5	Groundwater Flow Properties.....	34
3.5.6	Groundwater Quality .....	35

Table of Contents

---

3.5.6.1	General Characterization .....	35
3.5.6.2	Statistical Characterization.....	36
<b>4</b>	<b>Design Basis and Criteria .....</b>	<b>37</b>
4.1	Storm Water Design Criteria .....	37
4.2	Sediment and Control Erosion .....	41
4.2.1	Sediment and Erosion Sources.....	41
4.2.2	Best Management Practices .....	42
4.2.2.1	Vegetation Management .....	42
4.2.2.2	Soil Bioengineering .....	42
4.2.2.3	Mulching.....	43
4.2.2.4	Rolled Erosion Control Products.....	43
4.2.2.5	Surface Roughening .....	44
4.2.2.6	Re-contouring.....	44
4.2.2.7	Silt Fencing.....	44
4.2.2.8	Temporary Sediment Traps and Sediment Basins .....	44
4.2.2.9	Filter Bags and Geotubes .....	45
4.2.2.10	Flocculants .....	46
4.2.2.11	Collection Ditches .....	46
4.2.2.12	Diversion Ditches .....	47
4.2.2.13	Roadside Berms and Ditches.....	47
4.2.2.14	Culverts .....	47
4.2.2.15	Exfiltration Areas .....	47
4.3	Discharge Protocols.....	52
<b>5</b>	<b>Water Balance, Storm Water &amp; Groundwater .....</b>	<b>53</b>
5.1	Surface Water Balance Model .....	53
5.2	Heap Leach Water Balance Model .....	53
5.2.1	Deterministic Model.....	54
5.2.2	Stochastic Model .....	54
5.2.3	Operational Model .....	54
5.2.4	Heap Draindown.....	55
5.3	Water Quality Model.....	55
5.4	Storm Water Model .....	55
5.5	Groundwater Model.....	60
5.5.1	Conceptual Hydrogeologic Model .....	60
5.5.2	Groundwater Model Development.....	60
5.5.3	Model Results.....	61
5.5.3.1	Open Pit Advance and Mine Dewatering .....	61

	5.5.3.2	Groundwater Supply Extraction .....	61
	5.5.3.3	Flow in Haggart Creek .....	61
<b>6</b>		<b>Water Management Implementation .....</b>	<b>62</b>
	6.1	Key Water Management Facilities .....	63
	6.1.1	Lower Dublin South Sediment Control Pond.....	63
	6.1.2	Culverts, Ditches and Pipes .....	63
	6.1.2.1	Culverts .....	63
	6.1.2.2	Ditches .....	64
	6.1.2.3	Pipes .....	66
	6.1.3	Open Pit.....	66
	6.1.4	Heap Leach Facility .....	67
	6.1.5	Mine Water Treatment Plant .....	67
	6.2	Erosion and Sediment Control Plan Implementation .....	70
	6.2.1	Erosion and Sediment Control - Current Status.....	70
	6.2.2	Erosion and Sediment Control - Forward Planning.....	71
	6.3	Sanitary Wastewater Management.....	74
	6.4	Water Uses .....	74
	6.5	Frozen Material Management .....	74
	6.6	Maintenance and Monitoring Strategies .....	76
<b>7</b>		<b>Water Distribution.....</b>	<b>77</b>
	7.1	Fresh Water .....	79
	7.2	Process Water.....	79
	7.3	Potable .....	79
	7.4	Fire Suppression .....	79
	7.5	Dust Control .....	80
<b>8</b>		<b>References.....</b>	<b>81</b>

**List of Tables**

Table 1.2-1:	Project Schedule Controls on Water Management Strategies .....	4
Table 2.3-1:	Positions and Responsibility Summary.....	7
Table 2.3-2:	Water Management RACI Matrix.....	10
Table 2.3-3:	Engineers of Record .....	13
Table 3.2-1:	Climate Stations at the Eagle Gold Project .....	15
Table 3.2-2:	Snow Survey Stations at the Eagle Gold Project .....	15
Table 3.2-3:	Project (Site) Monthly and Mean Annual Temperatures.....	15

Table of Contents

---

Table 3.2-4:	Potential Evaporation (PE) Estimates for the Camp Site .....	16
Table 3.2-5:	Project Site Monthly Rainfall Data .....	17
Table 3.2-6:	Project Site Snow Survey Data.....	19
Table 3.2-7:	Maximum Monthly 24-hour Rainfall for the Camp Station (mm) .....	20
Table 3.2-8:	Maximum Monthly 24-hour Rainfall for the Potato Hills Station (mm).....	20
Table 3.2-9:	Recurrence Interval Estimates of 24-hour Storm Rainfall Depths (mm) .....	20
Table 3.4-1:	Eagle Gold Project Hydrometric Stations .....	24
Table 3.4-2:	Summary of Monthly Average Discharge, Unit Yield and Runoff for Project Site .....	24
Table 4.1-1:	Design Criteria .....	37
Table 4.2-1:	Temporary Sediment Basin Design Specifications.....	45
Table 5.4-1:	Catchment Areas Used in the Model .....	56
Table 5.4-2:	Flood Volume and Peak Runoff Values Estimated from the Rainfall Runoff Analysis.....	56
Table 6.1-1:	Effluent Quality Criteria.....	62
Table 6.1-2:	Culvert Specifications .....	64
Table 6.1-3:	Water Management Ditch Design Specifications .....	65
Table 6.1-4:	Collection Ditch Specifications.....	65
Table 7.1-1:	Fresh Water Capacities .....	79

**List of Figures**

Figure 1.1-1:	Property Location Map.....	2
Figure 1.1-2:	General Arrangement .....	3
Figure 3.2-1:	Climate Monitoring Stations and Snow Survey Locations.....	22
Figure 3.4-1:	Hydrometric Station Network .....	32
Figure 4.1-1:	Overview Plan Watershed Areas.....	40
Figure 4.2-1:	Culvert Sections and Details.....	48
Figure 4.2-2:	Erosion Control BMP - Sections and Details - Sheet 1 of 2 .....	49
Figure 4.2-3:	Erosion Control BMP - Sections and Details - Sheet 2 of 2 .....	50
Figure 4.2-4:	Haul Road Typical Cross Sections .....	51
Figure 4.2-5:	Mine Service Road Typical Cross Sections.....	51
Figure 5.4-1:	Eagle Gold Basin Model .....	58
Figure 5.4-2:	Lower Dublin South Pond Current Status.....	59
Figure 6.1-1:	Key Water Management Facilities Overview Plan.....	69

Figure 6.2-1: Installed Erosion and Sediment Control BMPs..... 73  
Figure 7.1-1: Mine Site Water Distribution Plan ..... 78

**List of Appendices**

Appendix A Flocculant Use Plan  
Appendix B As-Built Record Drawings  
Appendix C IFC Design Specifications, Drawing Package and Reissued Drawings

**List of Acronyms and Abbreviations**

% ..... percent  
< ..... less than  
> ..... greater than  
ADR ..... adsorption, desorption and recovery  
BC ..... British Columbia  
BGC ..... BGC Engineering Ltd.  
BMP ..... Best Management Practice  
CHP ..... corrugated metal half-pipe  
cm ..... centimetre  
CN ..... curve number  
°C ..... degrees Celsius  
EQS ..... effluent quality standards  
FMMP ..... Frozen Materials Management Plan  
GCL ..... geosynthetic clay liner  
ha ..... hectare  
hr ..... hour  
HLF ..... Heap leach facility  
IROSA ..... ice-rich overburden storage area  
km ..... kilometres  
km<sup>2</sup> ..... square kilometres  
L ..... litres  
LDSP ..... Lower Dublin South Pond  
LLDPE ..... linear low-density polyethylene  
m ..... metres  
masl ..... metres above sea level  
m<sup>2</sup> ..... square metres  
m<sup>3</sup> ..... cubic metres  
m/s ..... metres per second



MF .....microfiltration  
mg/L ..... milligrams per litre  
min .....minutes  
MIW ..... mine-influence water  
mm .....millimetre  
MWTP ..... mine water treatment plan  
pH.....potential of hydrogen (measure of acidity)  
PLS .....pregnant leach solution  
Project..... Eagle Gold Project  
PTS ..... passive treatment systems  
RECP ..... rolled erosion control products  
SGC ..... StrataGold Corporation  
WAD CN.....weak acid-dissociable cyanide  
WBM ..... water balance model  
WQM..... water quality model  
WRSA .....waste rock storage area

**THIS PAGE INTENTIONALLY LEFT BLANK**

# 1 INTRODUCTION

The Eagle Gold Project (the “Project”) is located about 85 kilometers (km) from Mayo, Yukon using existing highway and access roads (Figure 1.1-1). The Project involves open pit mining at a production rate of approximately 10.7 million tonnes per year ore. The open pit is being developed using standard drill and blast technology. Ore is removed from the open pit by haul truck and delivered to the first stage crushing plant (the primary crusher), situated on the north side of the open pit, passed through three crushing stages and then delivered to the heap leach facility (HLF) via conveyor belt. Gold is extracted using heap leaching, and a carbon Adsorption, Desorption, and Recovery (ADR) system over life of mine. Waste rock is removed from the open pit by haul truck and delivered to one of two waste rock storage areas. In the first year of mining, waste rock has been delivered to the (Platinum Gulch Waste Rock Storage Area (WRSAs), and as mining progresses the Eagle Pup WRSA will be opened.

Constructed water-related infrastructure includes a control pond (Lower Dublin South Pond or LDSP), Ditch A and the lower reach of Ditch B, the HLF events pond. Additional planned water-related infrastructure includes completing Ditch B, an ice-rich overburden storage area (IROSAs) and a mine water treatment plant (MWTP). The general layout of the mine and infrastructure components of the Project are presented in Figure 1.1-2.

The open pit is located to the south of the Dublin Gulch valley in the headwater areas of Suttles Gulch and Platinum Gulch. Mined rock that does not contain economic ore or cannot be used for construction is placed in the WRSAs.

Non-contact water has been and/or will be diverted, as feasible, around disturbed areas before discharging into receiving waters (i.e., Haggart Creek, Dublin Gulch and Eagle Creek). During operations the LDSP is used to retain water for HLF process make-up solution. A MWTP will be constructed during operations downstream of the HLF and adjacent to the LDSP to treat contact water when not needed for process make-up, and will discharge treated water into Haggart Creek. During closure, infrastructure will be decommissioned, covers will be placed on the WRSAs and the HLF, active water treatment systems will be in place and ultimately phased out as passive treatment systems are established.

## 1.1 PROJECT LOCATION AND BACKGROUND

The majority of the Project site lies within the Dublin Gulch watershed. Dublin Gulch is a second order stream that is a tributary to Haggart Creek which flows to the South McQuesten River. Elevations in the vicinity of the Project range from 730 meters above sea level (masl) in the Haggart Creek valley to 1,540 masl at the summit of Potato Hills (which forms the eastern boundary of the Dublin Gulch watershed).

Access to the Project site is from the Silver Trail (Highway 11) onto the existing South McQuesten Road and Haggart Creek Road. Together, the two roads comprise a 45 km road divided by the South McQuesten River.

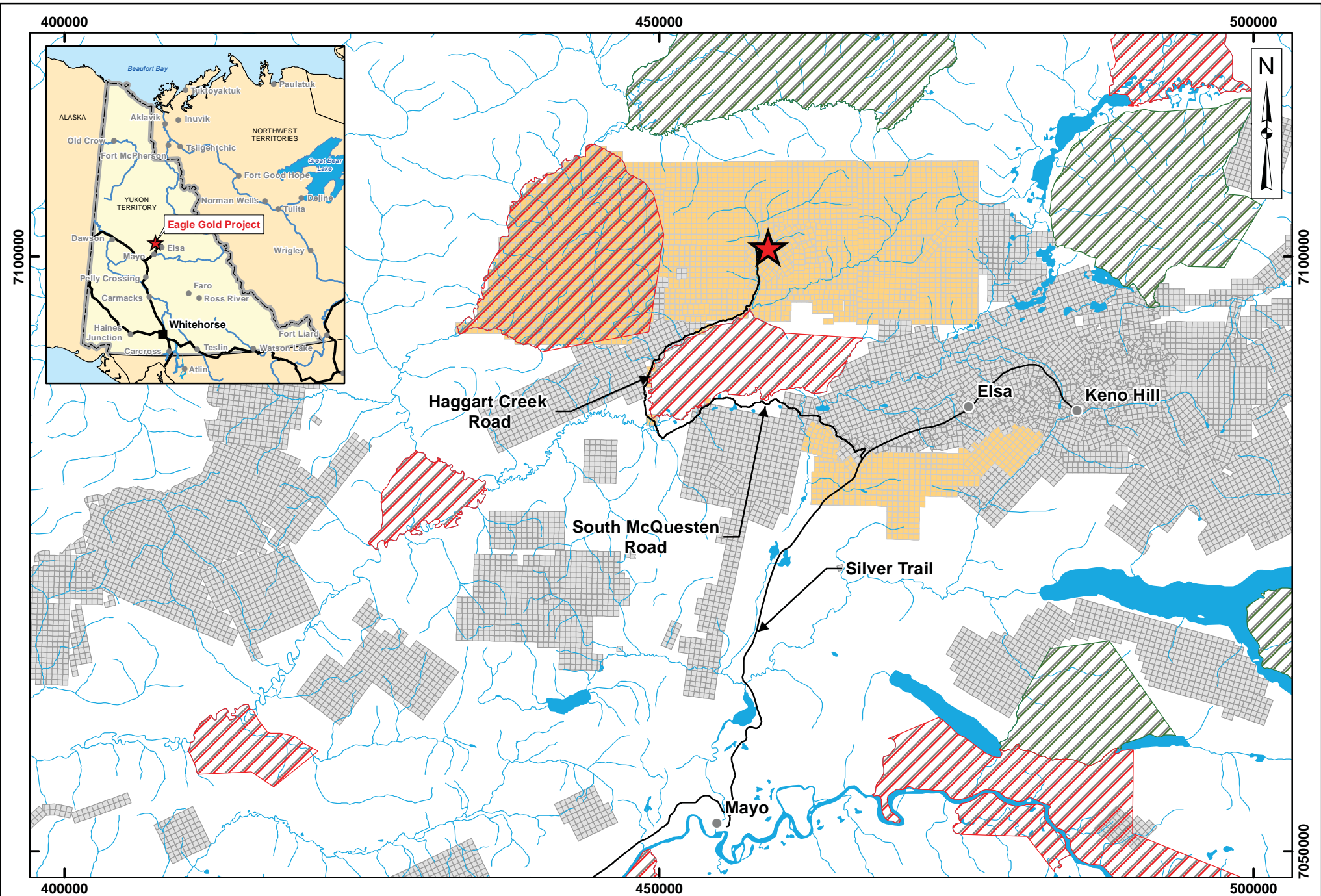

★ Eagle Gold Project	● Town / Village	▨ Category A Settlement Land
■ StrataGold Claims	— Road	▨ Category B Settlement Land
■ Other Claims	— Watercourse	

**StrataGold**  
Corporation

0 3 6 12  
Kilometres

Projection:	Drawn By:
NAD 83 Zone 8N	HC
Date:	Figure:
2017/03/15	1.1-1

**EAGLE GOLD PROJECT**  
**YUKON TERRITORY**

**Project Location**

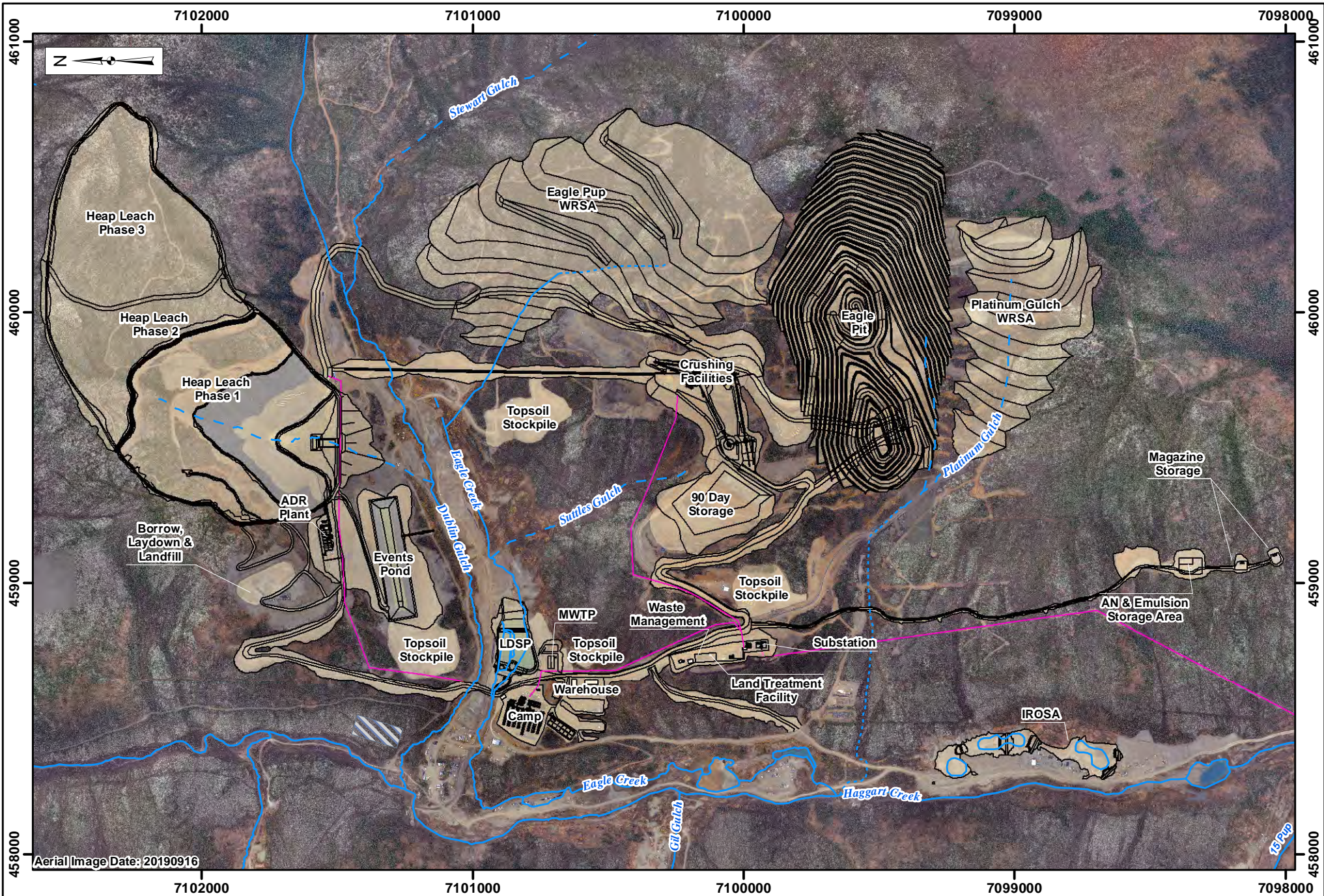

Aerial Image Date: 20190916

Legend:

- Facility
- Site Power
- ▨ Reserved Area
- Perennial
- - - Ephemeral
- · - · - Intermittent

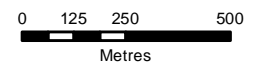

Projection:  
NAD 83 UTM  
Zone 8N

Date:  
2020/01/09

Drawn By:  
HC

Figure:  
1.1-2

**EAGLE GOLD PROJECT  
YUKON TERRITORY**

**General Arrangement**

## 1.2 PROJECT SCHEDULE

A summary of the project schedule is provided in Table 1.2-1. The schedule is conceptual and dependent upon various operational considerations.

**Table 1.2-1: Project Schedule Controls on Water Management Strategies**

Project Phase	Duration (yrs)	Controls on Water Management Strategies
Phase 1	3	Ramp-up and complete Phase 1 of Heap; contact water managed based on process make-up requirements, through adaptive water management strategies and continued development of future active treatment system based on operational monitoring data
Phase 2	2.5	Northward expansion of the HLF footprint and continued stacking; active treatment of contact water from the LDSP; progressive reclamation of PG WRSA; development of the PG PTS
Phase 3	2	Eastward expansion of the HLF footprint and continued stacking until the HLF reaches capacity; continued active treatment and development of the PG WRSA cover and PG PTS
Phase 4	1.0	Termination of mining and ore production, but continued irrigation of the ore stack for gold production; reclamation of EP WRSA and begin development of LDSP PTS, managed pumpback of heap drain-down solution; open pit begins to fill
Phase 5	2.0	Termination of gold production and period of rinsing and cyanide destruction; managed pumpback of heap drain-down solution – some heap discharge to treatment; LDSP and/or PG PTS discharge to Haggart Creek if criteria are met; open pit still filling
Phase 6	5.0	Controlled drain-down of heap (drain-down solution split into two flows: managed pumpback to heap and proportion sent to active treatment); begin conversion of Event Pond into HLF PTS; when flows and concentration criteria are met - change from active treatment to passive treatment of the heap seepage; open pit fills– flow allowed to drain to Haggart Creek (via PTS as necessary)
Phase 7	NA	Uncontrolled drainage of heap – seepage rate will ultimately meet rate of meteoric input; all passive treatment systems in place and meeting objectives and monitoring in effect
Phase 8	NA	Post-closure. Monitoring if required

## 1.3 DEFINITIONS

The term “sediment-laden water” is used to describe water that originates from disturbed areas (e.g., roads, foundation pads, etc.) and only needs treatment for sedimentation, which is done through the management practices described in this Plan. “Contact water” is used to describe water that will come into contact with the open pit, waste rock storage areas, or the heap leach facility. This type of water may require additional treatment (i.e., at the mine-water treatment plant, passive treatment system) during operations and/or closure prior to discharge to the environment. Conversely, “non-contact water” is used to describe water that has not come into contact with any Project facilities.

## 1.4 SCOPE OF PLAN

This Water Management Plan (the “Plan”) has been developed to proactively manage sediment-laden, contact and non-contact water within the Project site.

The Plan has several functional components, each developed from specific design basis and criteria, and supported by the integration of baseline studies and various water-related modeling exercises.

The Plan describes the capability of the site water management infrastructure to contain, control and convey short duration extreme rainfall events. Water management facilities are designed with two specific operating modes: 1)

service conditions, which include day-to-day operations and 2) ultimate limit conditions, which include provisions for safely handling extreme peak runoff events.

The sediment and erosion control section describes the best management practices (BMPs) that have been and will be implemented on site with appropriate flexibility for new control measures to allow the design elements to be field-fit to suit the conditions encountered (i.e., adaptive management approach).

The operations water management section describes water routing and key management facilities built during construction (e.g., control pond and events pond), and in addition to those facilities maintained for use into the operations phase.

Closure and post-closure water management is described in the Reclamation and Closure Plan.

## **2 WATER MANAGEMENT PLANNING**

### **2.1 OBJECTIVES**

The primary objective of this Plan is to protect and conserve water resources (including the water quality, water quantity, and the aquatic ecosystem) from impairment caused by the Project. Other objectives considered when developing design criteria include the following:

- Protect and prevent surface and ground water resources from potential contamination caused by the activities throughout the Project.
- Protect infrastructure from damage, to maintain safety and minimize financial costs for repair or replacement.
- Maximize water reuse and avoid contaminated water discharges.
- Maximize clean water runoff.
- Minimize the need for additional make-up water use.
- Prevent the discharge of sediment-laden water to surface water streams.
- Minimize the impact on the receiving environment.
- Encourage stabilization and regrowth of vegetation.

### **2.2 STRATEGIES**

The primary strategies for means of achieving the objectives listed above include:

- Separating waters of different quality, so that water quality deterioration is minimized. (i.e., diverting non-contact water away from disturbed areas).
- Minimizing the contact between water and potential contaminants, such as chemicals, petroleum products, or waste products.
- Erosion and pollution source control (i.e., minimizing total suspended solid levels in runoff from disturbed areas),
- Capture of contact water so that it can be treated, as necessary, prior to reuse or discharge back into the environment.

Management of non-contact water is best done by the redirecting of surface runoff away from disturbed areas. This process can be done by constructing small stable channels, swales, or ponds to capture as much of the surface runoff as possible, or by constructing small obstacles such as berms or other barriers, that will redirect the flow around a specific area.

Management of sediment-laden water is best done by reducing the velocity of water thus allowing sediments to settle. This process can be done by constructing channels with check dams, SCPs, sediment basins, exfiltration ponds, and sediment traps, as well as through the stabilization of disturbed land surfaces, and re-establishment of vegetative cover. Where final slopes are created, indigenous vegetation will be planted.



Management of contact water is best done by capturing as much of the water as possible in water management ponds, using this water for various mine operations (e.g., process water, dust control) and/or pumping the water to a treatment facility, where it can then be treated, as necessary, prior to recirculation/re-use or discharged back to the environment.

In summary, all water will need to be controlled in such a manner that minimizes erosion in areas disturbed by construction or operational activities and which prevents the release of contact water, which could adversely affect the quality of receiving waters (e.g., Dublin Gulch, Haggart Creek, and Eagle Creek).

## 2.3 EXECUTION STRATEGY

### 2.3.1 Roles and Responsibilities

To ensure that the Plan is executed effectively, clearly defined roles and responsibilities for water management design, construction and implementation are critical.

Table 2.3-1 provides details on the key positions within SGC that have responsibilities related to the execution of the Plan.

**Table 2.3-1: Positions and Responsibility Summary**

Position	Responsibilities and Accountabilities
Chief Operating Officer (COO)	<ul style="list-style-type: none"> <li>▪ Reports to CEO</li> <li>▪ Overall accountability for the operation of the Project</li> <li>▪ Oversight of resources (human and financial) for the implementation of SGC's commitments and objectives related to production, health and safety, and environment</li> <li>▪ Oversees on-site environmental and health and safety performance</li> </ul>
VP Operations and General Manager	<ul style="list-style-type: none"> <li>▪ Reports to COO</li> <li>▪ Overall accountability for the operation of the Project</li> <li>▪ Responsible for providing oversight for all Project operations and allocating the necessary resources for the operation, maintenance and management of Project infrastructure.</li> <li>▪ Accountable for on-site environmental, health and safety performance during operation</li> </ul>
Lands & Permitting Manager / Director of Technical Services	<ul style="list-style-type: none"> <li>▪ Reports to COO</li> <li>▪ Establish corporate environmental policies and objectives</li> <li>▪ Monitors and reports on SGC's performance related to environmental policies and objectives</li> <li>▪ Liaise with regulatory authorities</li> <li>▪ Monitors compliance with terms and conditions of permits and licences</li> <li>▪ Reviews and prepares updates for management plans</li> <li>▪ Support the management of Project water management infrastructure by advising operational departments and obtaining the appropriate regulatory approvals as necessary</li> </ul>
Environmental Manager	<ul style="list-style-type: none"> <li>▪ Reports VP Operations and General Manager</li> <li>▪ Liaises with the senior management, regulators and stakeholders</li> <li>▪ Ensures effective monitoring and auditing of environmental performance of departments and contractors on site and identifies opportunities for improvement</li> <li>▪ Monitors compliance with permits, licenses and authorizations</li> <li>▪ Ensures regulatory environmental monitoring and reporting requirements are met</li> <li>▪ Reviews and prepares updates for management plans</li> <li>▪ Oversees environmental studies and monitoring programs</li> <li>▪ Liaises with Operations managers to prioritise water management planning, infrastructure and initiatives</li> </ul>
Supply Chain Manager	<ul style="list-style-type: none"> <li>▪ Reports to Victoria Gold's VP Operations and General Manager</li> <li>▪ Accountable for procurement and purchasing, including water management infrastructure for the Project</li> <li>▪ Ensure that environmental commitments, policies and objectives are included in all contract documents</li> </ul>

Section 2 Water Management Planning

<b>Position</b>	<b>Responsibilities and Accountabilities</b>
Mine Operations Manager / Technical Services Superintendent	<ul style="list-style-type: none"> <li>▪ Reports to the VP Operations and General Manager</li> <li>▪ Provides oversight and is accountable for all Project mining operations, including the operation, construction and maintenance of water and waste management infrastructure at mining areas, stockpiles, WRSAs and along mine roads, including culverts, ditches, surface water management ponds and associated water treatment systems</li> <li>▪ Responsible for implementing identified water management mitigations and initiatives within functional area</li> </ul>
Process and Crushing Manager/ Superintendent	<ul style="list-style-type: none"> <li>▪ Reports to the VP Operations and General Manager</li> <li>▪ Provides oversight and is accountable for all ore crushing and processing operations, including the operation, construction and maintenance of surface water management infrastructure associated with the HLF, including culverts, ditches, surface water management ponds and any associated water treatment systems</li> <li>▪ Responsible for implementing identified water management practices and initiatives within functional area</li> </ul>
Site Services Manager	<ul style="list-style-type: none"> <li>▪ Reports to the VP Operations and General Manager</li> <li>▪ Provides oversight and is accountable for all Site Services operations, including the operation, construction and maintenance of water and waste management infrastructure including release of water from the LDSP</li> <li>▪ Responsible for managing water in containment areas associated with fuel facilities and hazardous materials/waste storage areas, including landfarm and landfill facilities</li> </ul>
General Foremen	<ul style="list-style-type: none"> <li>▪ Reports to the Manager/Superintendent of respective department</li> <li>▪ Responsible for providing leadership and direction to the Operations/Process function</li> <li>▪ Responsible for implementing identified water management practices and initiatives within functional area</li> </ul>
Maintenance Manager	<ul style="list-style-type: none"> <li>▪ Reports to the VP Operations and General Manager</li> <li>▪ Provides oversight and is accountable for all maintenance activities</li> <li>▪ Responsible for managing water in containment areas associated with maintenance equipment areas and any actual maintenance and service work sites</li> </ul>
Environmental Superintendent	<ul style="list-style-type: none"> <li>▪ Reports to VP Operations and General Manager</li> <li>▪ Overall accountability for environmental staff and performance at site</li> <li>▪ Coordinates implementation and monitors the performance of the Environmental Management Systems at site</li> <li>▪ Serves as the liaison for regulatory agents during onsite inspections and visits</li> <li>▪ Provides ongoing environmental education and environmental awareness training to all employees and contract workers</li> <li>▪ Prepares investigations and reporting of environmental incidents to regulatory bodies, stakeholders and senior management</li> <li>▪ Manages environmental studies and monitoring programs</li> <li>▪ Reviews and prepares updates for management plans</li> <li>▪ Works directly with site managers and supervisors to prioritise water management planning, infrastructure and initiatives</li> <li>▪ Advise operational departments on the implementation of the appropriate controls to manage surface water flows and contact water, including the implementation of sedimentation and erosion controls</li> </ul>
Environmental Coordinator	<ul style="list-style-type: none"> <li>▪ Reports to the Environmental Superintendent</li> <li>▪ Specific accountabilities for environmental monitoring, sampling and reporting as per Project management plans and regulatory approvals</li> <li>▪ Provides day to day direction to Environmental and Operations staff onsite in regards to water management</li> <li>▪ Serves as a liaison for regulatory agents during onsite inspections and visits</li> <li>▪ Provides ongoing environmental education and environmental awareness training to all employees and contract workers</li> <li>▪ Monitors and tracks water management infrastructure onsite</li> <li>▪ Supports updates of management plans</li> <li>▪ Works with site departments to inspect water management infrastructure</li> </ul>
Environmental Technician	<ul style="list-style-type: none"> <li>▪ Reports to the Environmental Coordinator</li> <li>▪ Works with operations to inspect water management infrastructure</li> </ul>

---

Position	Responsibilities and Accountabilities
	<ul style="list-style-type: none"><li data-bbox="380 319 1451 367">▪ Responsible for monitoring and sampling activities in conjunction with operations staff as per the Project's management plans</li></ul>

### 2.3.2 Responsibility, Accountability, Consultation and Information

To provide clarity with respect to all aspects of the execution of the Plan, a RACI matrix (Table 2.3-2) has been developed to provide staff with a clear graphic representation of the those SGC employees that are directly responsible for each aspect of the Plan.

Table 2.3-2: Water Management RACI Matrix

PROJECT TASK	PLAN SECTION	LEADERSHIP					OPERATIONS								
		COO	VP OGM	Lands Permitting Manager	Director Tech Services	Enviro Manager	Supply Chain Manager	Mine Ops Manager	Tech Manager Engineer Services	Process Manager	Site Services Manager	Maintenance Manager	Ops General Foremen / Super-intendents	Enviro Super-intendent	Enviro Coordinator / Technician
<b>PLANNING</b>															
Water Management Plan updates as needed	Water Use Licence	I	I	A	R	R	I	C	C	C	C	I	I	R	I
Technical Support for Water Management Plan	4, 5	I	I	C	A	I	I	I	C	C	I	I	I	R	I
Mine water treatment plant design	5	I	C	C	A	I	C	I	C	C	I	I	I	R	I
<b>IMPLEMENTATION</b>															
<b>KEY WATER MANAGEMENT FACILITIES</b>															
<b>LDSP</b>															
Decision to initiate discharge from LDSP (based on LDSP water levels, on site TSS, turbidity and recent lab results)	6.1.1	C	A	C	C	C	N/A	N/A	C	C	C	N/A	R	C	R
Operate the Low-Level Outlet (LLO) to initiate or cease discharge		I	I	I	I	I	N/A	N/A	N/A	C	A	N/A	R	C	R
Monitoring LDSP water quality discharge as per effluent quality criteria	4.3	I	I	C	C	C	N/A	N/A	N/A	N/A	C	N/A	R	A	R
Decision to cease discharge from LDSP (based on internal TSS/turbidity)	4.3, 6.1.1	C	A	C	C	C	N/A	N/A	N/A	N/A	C	N/A	R	C	R
<b>CULVERTS, DITCHES AND PIPES</b>															
Install culverts, ditches and pipes (excluding Open Pit)	6.1.2	I	I	I	I	C	I	C	C	N/A	A	N/A	R	C	R
<b>OPEN PIT</b>															
Manage open pit water and internal water transfers to Ditch A	6.1.3	I	I	I	C	C	N/A	A	C	N/A	C	N/A	R	C	R
<b>HLF</b>															
Initiate pumping from LDSP to HLF for process solution (based on process water needs)	6.1.4, 6.4	I	I	I	C	C	N/A	N/A	I	A	C	I	R	C	R
Initiate pumping from Event Pond to HLF for process solution (based on process water needs)		I	I	I	I	I	N/A	N/A	I	A	C	I	R	C	R
Initiate pumping from in-Heap Pond to ADR plant (based on in-Heap Pond water levels)		I	I	I	I	I	N/A	N/A	I	A	I	I	R	C	R

PROJECT TASK	PLAN SECTION	LEADERSHIP					OPERATIONS								
		COO	VP OGM	Lands Permitting Manager	Director Tech Services	Enviro Manager	Supply Chain Manager	Mine Ops Manager	Tech Manager Engineer Services	Process Manager	Site Services Manager	Maintenance Manager	Ops General Foremen / Super-intendents	Enviro Super-intendent	Enviro Coordinator / Technician
<b>MWTP</b>															
Construct MWTP	6.1.5	I	A	C	C	C	R	C	C	R	C	C	I	R	R
Commission MWTP		I	A	C	C	C	R	C	C	R	C	C	I	R	I
Operate MWTP		C	A	C	C	C	N/A	N/A	C	R	I	R	R	C	I
<b>EROSION AND SEDIMENT CONTROL PLAN IMPLEMENTATION</b>															
Incorporate Best Management Practices during operations	4.2.1, 4.2.2, 6.2.1	I	A	C	C	C	R	R	R	R	R	R	R	R	R
Construct additional sediment basins, exfiltration areas, berms, diversion ditches, rock energy dissipation structures, silt fencing	6.2.2	I	C	I	C	C	N/A	C	C	N/A	A	N/A	R	C	R
<b>SANITARY WASTEWATER MANAGEMENT</b>															
Management of potable water and sanitary wastewater	6.3	I	I	I	I	I	N/A	I	I	I	A	R	R	C	I
<b>WATER USES</b>															
Project-wide tracking of water distribution	6.4, 7	C	A	C	C	C	N/A	N/A	C	C	C	N/A	I	R	R
<b>FROZEN MATERIALS MANAGEMENT</b>															
Management of Ice-Rich Overburden	6.5	C	A	I	C	C	N/A	R	I	R	R	N/A	R	C	R
<b>MAINTENANCE AND MONITORING</b>															
Project-wide environmental sampling and monitoring	3.4.2	I	I	C	C	A	I	I	I	I	I	I	I	R	R
Open pit facilities	6.6	C	A	C	C	C	I	R	C	I	I	R	R	I	R
LDSP facilities		C	A	C	C	C	I	I	C	C	R	R	R	I	R
HLF facilities		C	A	C	C	C	I	I	C	R	I	R	R	I	R
Mine Water Treatment Plant		C	A	C	C	C	I	I	C	R	C	R	R	I	R
Sediment basins, ditches, pipes, exfiltration areas, culverts, berms, diversion ditches, rock energy dissipation structures, silt fencing		I	A	C	C	C	I	C	C	I	C	I	R	I	R

Section 2 Water Management Planning

PROJECT TASK	PLAN SECTION	LEADERSHIP					OPERATIONS								
		COO	VP OGM	Lands Permitting Manager	Director Tech Services	Enviro Manager	Supply Chain Manager	Mine Ops Manager	Tech Manager Engineer Services	Process Manager	Site Services Manager	Maintenance Manager	Ops General Foremen / Superintendents	Enviro Superintendent	Enviro Coordinator / Technician
<b>REPORTING</b>															
Monthly WUL reporting	Water Use Licence	I	I	C	C	A	N/A	C	C	C	C	C	N/A	R	R
Annual Inspections and reporting of key facilities		I	I	A	C	C	N/A	C	C	C	C	C	N/A	N/A	N/A
Annual reporting of water management strategies, usage, and distribution		I	I	C	C	A	N/A	C	C	C	C	C	N/A	R	R
Emergency Response Reporting for LDSP discharges exceeding effluent criteria		C	A	C	C	C	N/A	N/A	N/A	N/A	C	N/A	N/A	R	R

### 2.3.3 Engineers of Record

Table 2.3-3 provides the Engineers of Record (EoR) for the design, construction and operation for the identified Engineered Structures on the Project.

**Table 2.3-3: Engineers of Record**

Structure	EoR Design	EoR Construction	EoR Operation	Status
Heap Leach Facility	Phase 1A -Troy Meyer Phase 1B - Barry Carlson	Phase 1A - Troy Meyer Phase 1B - Barry Carlson	Barry Carlson	Construction of the following components complete: <ul style="list-style-type: none"> <li>▪ Embankment</li> <li>▪ Phase 1A liner system</li> <li>▪ Phase 1A underdrains</li> <li>▪ Phase 1A PLS pipe network</li> <li>▪ Phase 1A barren solution pipe network</li> </ul>
Events Pond	Troy Meyer	Troy Meyer	Barry Carlson	Construction Complete. No modifications made nor required since construction completion. EoR "As-Built" information in final review.
Lower Dublin South Pond	Mauricio Herrera	Mauricio Herrera	N/A No alteration made to facility since completion of construction.	Construction complete.
Ditches A, B, C and 90 Day stockpile connection	Mauricio Herrera	Mauricio Herrera	N/A EoR responsible for construction of additional features will be identified in future submission	Construction of the following components complete: <ul style="list-style-type: none"> <li>▪ Ditch A, Ditch A pipe, and PG sump</li> <li>▪ Ditch B STN 0+000 to ST0+314</li> <li>▪ Ditch C</li> </ul> Additional construction will be undertaken when water management infrastructure is required to manage surface runoff and seepage from newly disturbed areas
Waste Rock Storage Area	Steve Tang	Mike Levy	Mike Levy	Facility development will continue for the life of mine.
Rock Drain – Waste Rock Storage Area	Kevin Jones	Mike Levy Richard Tuohey	Richard Tuohey	Facility development will continue for the life of mine.
IROSA	Adam Wallace	N/A	N/A	Facility construction has not commenced.
Open Pit	Michael Levy	Richard Tuohey	Richard Tuohey	Facility development will continue for the life of mine.
MWTP	Samuel Billin	N/A	N/A	Facility Construction has not commenced.

### 3 ENVIRONMENTAL CONDITIONS

A Hydrometeorology Report (Lorax, 2017a) was completed for the Project to provide long-term estimates for various meteorological and hydrological parameters that acted as the basis for assembly of hydro-meteorological inputs that were used in the design of water management structures prior to their construction. Hydrometeorological interpretation is ongoing to support refinement and update of various water balance models for the Project area and for future design considerations as necessary.

The discussion provided herein includes recent climate and hydrology data collected for the Project site (Lorax 2019 a and b)

The long-term estimates provided in Lorax (2017a) were based on regional datasets and available site data from 2007 to 2016. Lorax (2017a) summarizes, integrates, and analyses data collected at the Project site as well as regional data from Environment Canada and Yukon Environment. Prior to finalization of water management infrastructure, the design engineers reviewed more recent data collected to confirm that the characterization work undertaken remained appropriate for their design as required by the Type A Water Use Licence QZ14-041 (and subsequently QZ14-041-1)

The long-term estimates considered for the design of water management infrastructure are discussed further in Section 5.

#### 3.1 REGIONAL SETTING

The Project is located within the Boreal Cordillera ecozone, which comprises much of the southern Yukon and a large portion of northern British Columbia, and more specifically within the Yukon Plateau-North ecoregion. The Boreal Cordillera ecozone is broadly characterized by the presence of several mountain ranges that trend in the northwesterly direction and include extensive plateau regions. The plateaus consist of flat or gently rolling upland terrain separated by broad valleys and lowlands.

The climate is characterized by long, cold, dry winters and short, warm, periodically wet summers, with conditions varying according to altitude and aspect. Streamflow in the region is typically highest in May due to melting of the winter snowpack. Annual peak instantaneous flows commonly occur in this freshet period on larger rivers, but on smaller streams they may also occur in summer or early autumn due to intense rain or rain on snow events. Flows decrease throughout the winter and minimum flows typically occur in March or April.

#### 3.2 CLIMATE

##### 3.2.1 Project Site

The information on the Project climate stations and snow survey stations is presented in Table 3.2-1 and Table 3.2-2, and the locations are shown in Figure 3.2-1. Climatic parameters are measured at the Project site by two weather stations. The Potato Hills station is situated near the eastern basin divide (1,420 m), and was installed in August 2007. The second station was originally installed near the camp at 823 m in August 2009, and subsequently moved to its current location in September 2010 at 782 m due to construction of new camp facilities.



**Table 3.2-1: Climate Stations at the Eagle Gold Project**

Station	Elevation (m asl)	UTM E	UTM N	Record Period
Camp Station	782	458,164	7,101,036	2009-present
Potato Hills Station	1,420	463,544	7,100,833	2007-present

**Table 3.2-2: Snow Survey Stations at the Eagle Gold Project**

Station	Elevation (m asl)	UTM E	UTM N	Record Period
Camp Snow Survey	782	458,164	7,101,036	2009-present
Ann Gulch Snow Survey	875	458,945	7,101,185	2012-2017
Stewart (Snow Survey #2)	995	460,570	7,101,490	Mar 2012 only
Potato Hills Snow Survey	1,420	463,290	7,100,568	2009-present

### 3.2.2 Temperature

Air temperatures at the Project site are consistent with those throughout the Yukon interior. As indicated in Table 3.2-3 below, mean annual air temperature at site is -3.2°C at the Camp station (782 m) and -3.8 °C at the Potato Hills station (1,420 m) over their respective periods of record. At the Camp station, monthly average temperature ranges from -19.3°C in January to 13.2°C in July, and -15.0°C to 10.8°C at the Potato Hills station, for the same months. The minimum (maximum) recorded daily average temperatures were -43.8°C (22.0°C) and -36.6°C (22.8°C) at the Camp and Potato Hills stations, respectively.

The monthly mean temperatures signatures for both climate stations are shown in Table 3.2-3, and the pattern is consistent with the larger regional picture. During the months of March to October inclusive, the standard lapse rate applies, with temperatures decreasing with rising elevation, and are approximately 3°C cooler at the upper station, on average. However, during the winter months of November to February, temperature inversions are common at the Project site as per the broader region, with temperatures roughly 2.5°C cooler on average in the valley bottom than at the height of land.

**Table 3.2-3: Project (Site) Monthly and Mean Annual Temperatures**

Station	Jan	Feb	Mar	Apr	May	Jun	Jul	Aug	Sep	Oct	Nov	Dec	Annual
Camp	-19.3	-17.3	-12.4	-1.7	7.3	12.2	13.2	10.7	4.5	-3.6	-17.1	-19.9	-3.2
Potato Hills	-15.0	-14.1	-12.3	-4.4	5.0	9.8	10.8	8.2	2.3	-5.6	-13.5	-15.2	-3.8

Source: Lorax (2019a)

### 3.2.3 Potential Evaporation

As described in Lorax (2019a) 15-minute potential evaporation rates were computed for the Camp station using available climate and the Ref-ET calculator - a compiled, standalone computer program that calculates reference evapotranspiration (ASCE 2005). For the period of available record (Jan 2013 to Dec 2017), a 15-minute climate input file was prepared for the Eagle Gold Site. The input variables required by Ref-ET are: maximum air temperature, minimum air temperature, relative humidity, incoming solar radiation, atmospheric pressure and wind speed.

Section 3 Environmental Conditions

From the assembled climate inputs, Ref-ET returned potential evaporation (PE) computations for an array of evaporation models (e.g., Penman-Monteith model, Priestley- Taylor formulation), which were aggregated to daily time-step. Presented in Table 3.2-4 (monthly tabulations) are resulting outputs from Ref-ET for months March to October.

May to end-September PE estimates for the Camp station are also reported in Table 3.2-4 and are estimated to range from 380 - 400 mm over this period. In terms of monthly magnitudes of PE, highest monthly rates of PE are expected in May, June, July and August of each year.

**Table 3.2-4: Potential Evaporation (PE) Estimates for the Camp Site**

Period	Method	Potential Evaporation (mm)							
		2012	2013	2014	2015	2016	2017	2018	Average (2012-2017)
Mar	PM	-	17	21	17	24	18	20	20
	P-T	-	16	19	16	16	13	25	17
Apr	PM	-	40	47	47	57	56	51	50
	P-T	-	40	46	46	48	50	59	48
May	PM	-	78	91	113	106	97	78	94
	P-T	-	82	85	108	86	80	83	87
June	PM	-	114	98	97	126	---	94	106
	P-T	-	116	96	97	109	---	99	103
July	PM	87	102	91	80	91	---	108	93
	P-T	93	102	90	86	86	---	113	95
August	PM	69	74	55	61	79	83	60	69
	P-T	70	73	56	63	67	68	67	66
Sep	PM	36	30	33	27	45	34	44	36
	P-T	26	24	28	23	30	25	49	29
Oct	PM	6	3	10	10	12	5	14	9
	P-T	4	3	4	5	5	4	17	6
Total (Mar-Oct)	PM	-	461	441	455	541	---	470	474
	P-T	-	453	419	440	447	---	511	454
Total (May-Sep)	PM	-	397	367	378	448	---	384	395
	P-T	-	397	354	378	378	---	410	383

Notes: *PM and P-T* Indicate potential evaporation (PE) estimates based on Penman–Monteith and Priestley–Taylor approaches respectively. 2. PE Estimates computed using Eagle camp/lower 15-min climate data (i.e., air, temperature, relative humidity, wind speed, precipitation solar radiation, atmospheric pressure) and Ref-Et software.

### 3.2.4 Precipitation

Precipitation data is collected at the Project site using tipping bucket rain gauges, which have not been adapted to measure snowfall. Therefore, the precipitation data presented in Table 3.2-5 is for rainfall only, collected between the months of March and October, inclusive. Generally, precipitation falls as snow from November through March, with precipitation falling as a mix of rain and snow in April and October. Rainfall data for March is included in the table below, where the temperature record indicates that precipitation would have fallen as rain (i.e., daily average air temperature was above zero).

**Table 3.2-5: Project Site Monthly Rainfall Data**

Climate Station	Elevation (ma sl)	Rainfall (mm)														
		Year	Jan	Feb	Mar	Apr	May	Jun	Jul	Aug	Sep	Oct	Nov	Dec	Annual	
Camp Station	782	2009	-	-	-	-	-	-	-	-	-	35.0	8.0	S	S	-
		2010	S	S	5.0	9.0	20.0	62.0	34.0	28.0	25.0	12.0	S	S	195.0	
		2011	S	S	11.0	10.0	16.0	31.0	75.0	44.0	40.0	9.0	S	S	236.0	
		2012	S	S	13.0	1.0	22.0	18.0	74.6	29.8	24.0	4.8	S	S	187.2	
		2013	S	S	8.6	10.4	34.6	25.6	28.4	35.2	58.6	25.2	S	S	226.6	
		2014	S	S	5.4	8.8	9.2	52.8	43.2	70.4	28.8	23.2	S	S	241.8	
		2015	S	S	20.8	13.0	8.2	28.8	64.0	62.0	38.6	13.4	S	S	248.8	
		2016	S	S	6.2	4.4	14.0	32.6	55.0	31.0	25.6	2.6	S	S	171.4	
		2017	S	S	S	2.2	24.4	M	M	12.8	20.4	6.0	S	S	-	
		2018	S	S	12.0	1.4	63.2	49.4	1.6	34.4	4.6	12.4	S	S	179.0	
		All Years	Mean	S	S	10.3	6.7	23.5	37.5	47.0	38.6	30.1	11.7	S	S	210.7
	Max	S	S	20.8	13.0	63.2	62.0	75.0	70.4	58.6	25.2	S	S	248.8		
	Min	S	S	5.0	1.0	8.2	18.0	1.6	12.8	4.6	2.6	S	S	171.4		
Potato Hills Station	1420	2007	-	-	-	-	-	-	-	24.0	100.8	2.0	S	S	-	
		2008	S	S	3.4	4.8	58.4	52.0	201.2	130.0	11.2	1.2	S	S	462.2	
		2009	S	S	S	3.0	-	50.8	12.6	75.4	44.4	1.2	S	S	-	
		2010	S	S	1.0	6.2	16.4	77.2	45.8	39.4	4.2	5.4	S	S	195.6	
		2011	S	S	0.2	7.2	21.2	38.0	92.8	83.8	34.4	0.4	S	S	278.0	
		2012	S	S	S	0.6	9.6	24.2	64.8	37.8	21.0	4.6	S	S	162.6	

Climate Station	Elevation (ma sl)	Rainfall (mm)														
		Year	Jan	Feb	Mar	Apr	May	Jun	Jul	Aug	Sep	Oct	Nov	Dec	Annual	
		2013	S	S	2.2	0.2	29.6	33.2	18.0	18.2	63.8	<i>10.0</i>	S	S	175.2	
		2014	S	S	S	M	M	M	M	M	M	M	S	S	-	
		2015	S	S	M	M	M	M	M	48.5	27.1	<i>10.0</i>	S	S	-	
		2016	S	S	D	D	14.5	23.0	38.3	42.6	24.6	<i>0.6</i>	S	S	-	
		2017	S	S	D	D	16.2	25.8	46.3	21.8	53.0	<i>6.1</i>	S	S	-	
		2018	S	S	D	D	D	46.5	13.5	77.0	4.0	<i>3.8</i>	S	S	-	
		All Years	Mean	S	S	S	3.7	27.0	45.9	72.5	57.1	38.4	4.4	S	S	254.7
			Max	S	S	S	7.2	58.4	77.2	201.2	130.0	100.8	<i>10.0</i>	S	S	462.2
			Min	S	S	S	0.2	9.6	24.2	12.6	18.2	4.2	<i>0.4</i>	S	S	162.6

Notes:

1. Winter precipitation data (October through April in many years) are unreliable due to the majority falling as snow. The months where no rainfall was recorded due to freezing conditions are denoted by an 'S'.
2. Data for the month of October are in italics, as rainfall is not measured for the entire month.
3. 'M' denotes data missing due to a sensor malfunction.
4. In August 2015, the primary rain gauge at the Potato Hills Station was replaced by a standalone tipping bucket rain gauge. The replacement gauge is deployed each spring (i.e., in April or May) then decommissioned in the autumn (October). Missing data at Potato Hills Station denoted by 'D' indicate time periods during which the standalone tipping bucket rain gauge was not deployed.

### 3.2.5 Snow Accumulation and Snowmelt

Snow data have been collected at three snow courses at the Project site since 2009. Furthermore, the annual maximum snow water equivalent (SWE) value generally occurs in late-March or early-April at the Project site. Field measurements from site show that snow density is generally lower earlier in the season, corresponding to colder temperatures, but increases through winter as the snow pack deepens, weathers and as snow melt progresses.

Project site snow survey data is summarized in Table 3.2-6 for period of record 2009 to 2018. Annual maximum SWE values range from 93 mm to 161 mm at the Camp snow course, 98 mm to 117 mm (shorter record) at the Ann Gulch snow course, and vary from 190 mm to 410 mm at the Potato Hills snow course.

The Potato Hills snow survey was conducted in the immediate vicinity of the weather station from 2009 to 2011. However, due to the exposed location, snow redistribution resulted in variable measurements, and therefore the survey was moved to its current and more representative location in 2012, several hundred meters to the south-east (Figure 3.2-1). Note that high snowpacks did not allow access to the Potato Hills snow course in March 2012, and therefore the survey was conducted at Stewart Gulch (Snow Survey #2; Figure 3.2-1).

**Table 3.2-6: Project Site Snow Survey Data**

Year	Camp Station				Ann Gulch (Snow Survey #2)				Potato Hills Station			
	Survey Date	Depth (cm)	SWE (mm)	Density (%)	Survey Date	Depth (cm)	SWE (mm)	Density (%)	Survey Date	Depth (cm)	SWE (mm)	Density (%)
2009	2009-04-21	69	112	16%	-	-	-	-	2009-04-21	126	410	33%
2010	2010-03-31	50	99	20%	-	-	-	-	2010-03-31	103	278	27%
	2010-04-21	69	112	16%	-	-	-	-	2010-04-21	126	405	32%
2011	2011-03-28	55	93	17%	-	-	-	-	2011-03-28	105	251	24%
2012	2012-03-20	78	161	21%	-	-	-	-	2012-03-20 <sup>1</sup>	99	237	24%
	2012-04-20	56	79	14%	-	-	-	-	2012-04-22	117	262	22%
2013	-	-	-	-	2013-02-20	70	97	14%	2013-02-28	96	185	19%
	2013-03-02	61	108	18%	2013-03-02	67	115	17%	-	-	-	-
	2013-04-02	59	108	18%	2013-04-02	62	117	19%	2013-04-03	90	190	21%
					2013-04-16	62	85	14%	-	-	-	-
	2013-05-05	58	106	18%	2013-05-03	58	105	18%	2013-05-05	117	167	14%
2014	2014-03-12	57	126	22%	2014-03-12	51	94	18%	2014-03-11	98	276	28%
	2014-04-02	55	100	18%	2014-04-02	46	98	21%	2014-04-02	96	275	29%
	-	-	-	-	-	-	-	-	2014-05-08	70	258	37%
2016	2016-03-02	53	118	22%	2016-03-02	53	117	22%	2016-03-02	95	214	22%
	2016-04-09	38	140	37%	2016-04-09	22	115	52%	2016-04-10	107	257	24%
	-	-	-	-	-	-	-	-	2016-05-03	95	226	24%
2017	2017-03-17	51	89	17%	2017-03-17	50	100	20%	2017-03-17	84	206	25%
	2017-04-13	46	117	25%	2017-04-13	30	82	27%	2017-04-13	98	244	25%
	2017-05-04	7	28	40%	2017-05-04	0	0	NA	2017-05-03	89	236	27%
2018	2018-02-28	53	100	19%	-	-	-	-	2018-02-28	85	203	24%
	2018-04-04	54	109	20%	-	-	-	-	2018-04-04	91	219	24%
	2018-05-16	0	0	0%	-	-	-	-	2018-05-16	81	226	28%

Notes:

1. Snow survey data for Potato Hills collected on 2012-03-20 is from Stewart Gulch survey (Snow Survey #2) at 995 masl.
2. No snow surveys were conducted at site in 2015.

### 3.2.6 Extreme Rainfall/Snowmelt

The derivation of extreme rainfall/snowmelt events are important input criteria for the design of water management infrastructure to ensure that extreme events can be adequately managed. Estimates of the 24-hour rainfall for various return periods were developed in 2017 to support the design of key Project infrastructure. The specific

Section 3 Environmental Conditions

infrastructure designs informed by these estimates have either been constructed or will have the input criteria confirmed prior to their construction.

Estimates of the 24-hour rainfall for various return periods were computed in three ways. The first method used the rainfall Intensity-Duration-Frequency (IDF) curves published by Environment Canada for the Mayo A climate station, and the second method used the longer daily rainfall record from the Mayo A station. For reference, the values determined by the two methods were compared to an older and highly conservative method using a frequency factor approach, as presented in the Rainfall Frequency Atlas for Canada (Hogg and Carr, 1985).

For comparison with the estimated rainfall values, the monthly maximum 24-hour rainfall totals are presented in Table 3.2-7 and Table 3.2-8, for the Camp and Potato Hills climate stations, respectively.

The values derived from the scaled Mayo A daily data (highlighted in grey) reported in Table 3.2-9 were recommended for use in engineering design.

**Table 3.2-7: Maximum Monthly 24-hour Rainfall for the Camp Station (mm)**

Month	2009	2010	2011	2012	2013	2014	2015	Max
May	--	9.6	5.6	7.6	6.6	4.0	3.8	9.6
Jun	--	15.2	8.4	6.6	4.6	14.0	7.2	15.2
Jul	--	8.0	17.8	22.0	9.4	11.2	14.0	22.0
Aug	11.2	15.4	14.0	14.0	19.8	13.2	16.8	19.8
Sep	8.6	8.4	8.2	8.8	15.8	8.6	15.4	15.8
Max	11.2	15.4	17.8	22.0	19.8	14.0	16.8	22.0

Source: Lorax (2017a)

**Table 3.2-8: Maximum Monthly 24-hour Rainfall for the Potato Hills Station (mm)**

Month	2007	2008	2009	2010	2011	2012	2013	Max
May	--	14.8	0.0	7.8	6.2	2.4	7.0	14.8
Jun	--	16.4	14.4	20.4	13.4	7.2	8.0	20.4
Jul	--	27.0	5.0	16.2	17.2	17.0	3.6	27.0
Aug	14.2	38.2	12.6	20.2	19.8	16.2	6.2	38.2
Sep	35.8	4.0	9.2	1.8	12.8	6.8	10.0	35.8
Max	35.8	38.2	14.4	20.4	19.8	17.0	10.0	38.2

Source: Lorax (2017a)

**Table 3.2-9: Recurrence Interval Estimates of 24-hour Storm Rainfall Depths (mm)**

Exceedance Probability	Return Period	Mayo A	Camp		Project			Potato Hills	
		504 m	782 m		1125 m			1420 m	
		IDF	Daily <sup>1</sup>	IDF <sup>2</sup>	Daily <sup>1</sup>	IDF <sup>2</sup>	ARFA <sup>3</sup>	Daily <sup>1</sup>	IDF <sup>2</sup>
0.5	1:2	18	22	20	25	23	31	36	26
0.1	1:10	25	33	28	38	32	49	54	36
0.04	1:25	29	39	32	44	37	58	63	42
0.02	1:50	31	43	35	49	40	65	70	44
0.01	1:100	34	47	38	54	43	72	77	49

Exceedance Probability	Return Period	Mayo A	Camp		Project			Potato Hills	
		504 m	782 m		1125 m			1420 m	
		IDF	Daily <sup>1</sup>	IDF <sup>2</sup>	Daily <sup>1</sup>	IDF <sup>2</sup>	ARFA <sup>3</sup>	Daily <sup>1</sup>	IDF <sup>2</sup>
0.005	1:200	39 <sup>4</sup>	51	44	58	50	78	83	56
0.001	1:1000	43 <sup>4</sup>	60	48	69	55	94	99	62
PMP	PMP	--	--	--	--	--	256	--	--

Source: Lorax (2017a)

Notes:

- 1 Based on the Mayo A annual maximum daily rainfall, multiplied by 1.18, and scaled by elevation.
- 2 Based on the Mayo A 24-hour IDF curve estimates, and scaled by elevation.
- 3 Based on the Adjusted Rainfall Frequency Atlas method (Knight Piésold 2013).
- 4 IDF curve values not provided for these recurrence intervals – values in table based on extrapolation.

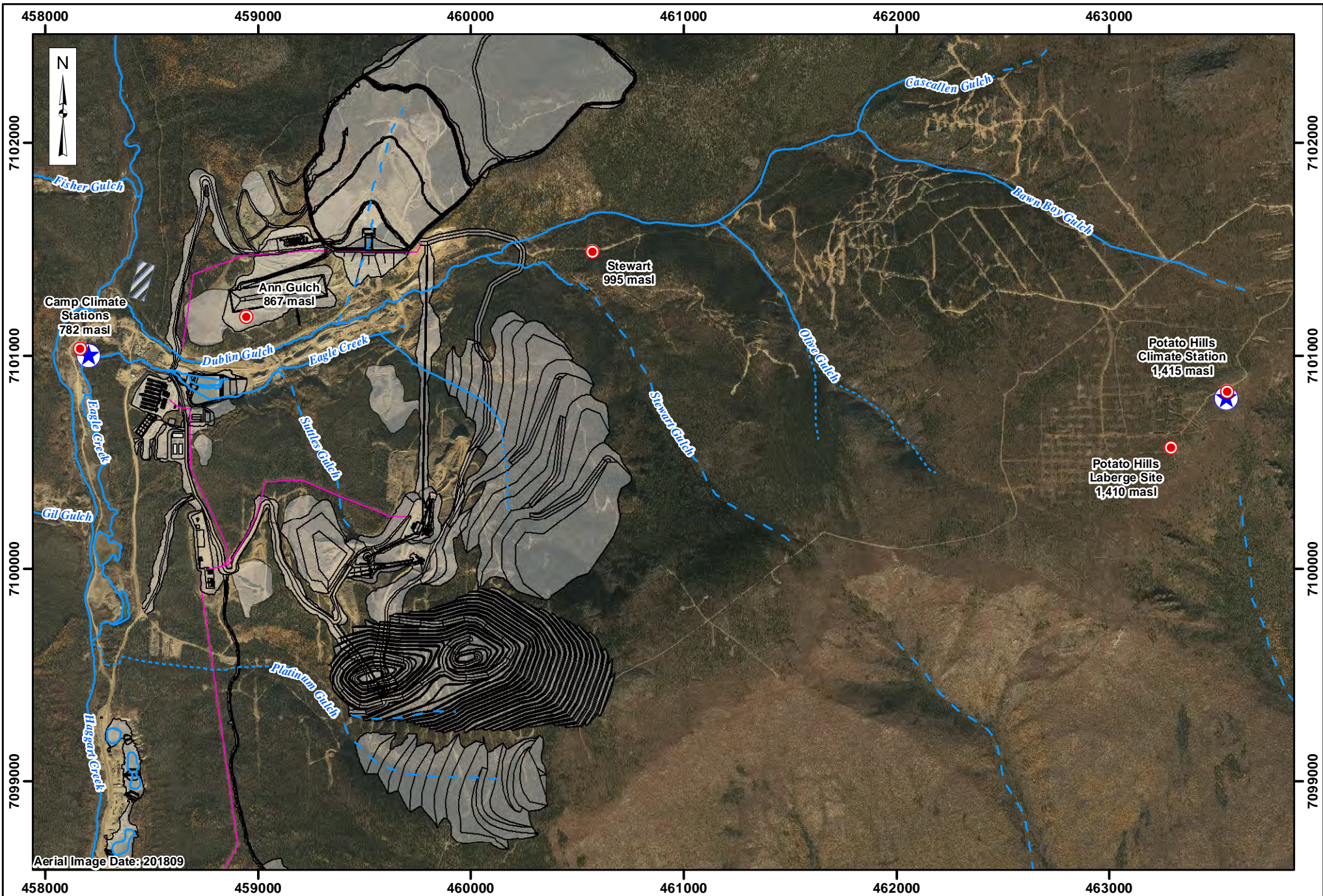

Legend:

Climate Station	Facility	Perennial
Snow Survey Sites	Site Power	Ephemeral
Reserved Area	Intermittent	

StrataGold Corporation

0 150 300 600  
Metres

Projection: NAD 83 UTM Zone 8N	Drawn By: HC
Date: 2020/01/09	Figure: 3.2-1

**EAGLE GOLD PROJECT  
YUKON TERRITORY**

**Climate Monitoring Stations  
& Snow Survey Locations**



### 3.3 PHYSIOGRAPHY

The project is located within the Mayo Lake-Ross River Ecoregion, which encompasses the Stewart, Macmillan, and Pelly plateaus, a subdivision of the Yukon Plateau physiographic subdivision. Terrain consists of rolling upland plateaus and small mountain groups with nearly level tablelands dissected by deep and broad U-shaped valleys. Most of the terrain in the region lies between 500 and 1,700 m asl, while most of the slopes in the project area are between 15 to 30%. The local study area lies in the upper regions of the Haggart Creek drainage basin, including the Dublin Gulch and Eagle Creek sub-basins. Haggart Creek flows generally southwestward and into the South McQuesten River which ultimately eventually flows to the Stewart River.

Placer mining has been conducted in both Haggart Creek and the Dublin Gulch basins over the past century. The outcome of these operations resulted in large placer deposits which altered the natural drainage character of Dublin Gulch, including channel diversions and some changes to sub-basin divides. The most notable changes affected Eagle Pup and Suttles Gulch. These water courses formerly entered into Dublin Gulch in the lower part of the valley. However, as a result of the placer mining activities, these drainages were diverted and helped to form Eagle Creek. As a result of constructing the mine, the Eagle Creek drainages have been further altered, principally by the construction of the LDSP along the drainage path. This is described more fully in Section 6.1.1. After leaving the Dublin Gulch valley, Eagle Creek turns southward and flows parallel to Haggart Creek for several kilometres through placer deposits including several ponds before draining to Haggart Creek downstream of the mouth of Gil Gulch. Lynx Creek, the largest tributary to Haggart Creek, meets Haggart Creek about 3 km downstream of the Eagle Creek-Haggart confluence.

### 3.4 SURFACE WATER

#### 3.4.1 Streamflow

Eight currently operating hydrometric stations with the most complete records are described in Lorax (2019b) and include streamflow monitoring stations in Dublin Gulch, Haggart Creek, Lynx Creek, Stewart Gulch and Eagle Creek. Station locations and the associated metadata are presented in Figure 3.4-1 and Table 3.4-1, respectively,

Lorax (2019b) provides a recent summary of all hydrometric data, and includes a summary of discharge measurement techniques, stage measurements and corrections, QA/QC of field data, approach and methods for hydrometric record assembly, and rating curve development and error. Over time, manual discharge measurements have been conducted using the following methods: velocity area techniques using a current meter; salt dilution; calibrated V-notch weir; calibrated Parshall flume; bucket/bag; and float-area method.

All hydrometric stations at the Eagle Gold Project were instrumented with metric staff gauges and continuously recording HOBO pressure transducers set to record water levels every 15 minutes.

To develop continuous time-series of discharge for the Project streams, spot measurements of stage and discharge were combined with continuous water level records collected by the pressure transducers. Rating curves were derived to describe the relationship between water level and discharge unique and specific to each monitoring station, and then applied to the continuous water level records to estimate discharge.

Table 3.4-2 provides a summary of monthly average discharge, unit yield and runoff for Project site hydrometric stations listed in Table 3.4-1. Flow records for all stations are presented in this format and as unit yield plots in Lorax (2019b).

**Eagle Gold Project**  
Water Management Plan

Section 3 Environmental Conditions

Available site data confirm streamflow patterns seen in the regional record. The characteristic snowmelt driven freshet signature, which typically occurs between early May and early June is evident at site hydrology stations. The recession limb of the freshet tapers to a summer low-flow regime reflective of primarily groundwater, which is punctuated by periodic rainfall driven runoff events, typically one to four days in duration. Air temperatures at the Project site begin to drop below zero in September. Accordingly, many of the smaller tributaries experience low- or zero-flow conditions for the majority of the winter season.

**Table 3.4-1: Eagle Gold Project Hydrometric Stations**

Station ID	Station Name	Record Period	Northing	Easting	Drainage Area (km <sup>2</sup> )	Median Basin Elevation (m)	Notes
W1	Dublin Gulch above Stewart Gulch	2007 - Date	7,101,545	460,249	6.8	1,303	Continuous discharge time-series
W4	Haggart Creek below Dublin Gulch	2007 - Date	7,101,223	458,144	76.9	1,125	Continuous discharge time-series
W5	Haggart Creek above Lynx Creek	2007 - Date	7,095,888	457,815	97.5	1,091	Continuous discharge time-series
W6	Lynx Creek above Haggart Creek	2007 - Date	7,095,964	458,099	100.9	1,049	Continuous discharge time-series
W22	Haggart Creek above Dublin Gulch	2007 - Date	7,101,377	458,319	66.8	1,113	Continuous discharge time-series
W26	Stewart Gulch	2007 - Date	7,101,443	460,331	1.3	1,183	Continuous discharge time-series, manual data only for 2007 - 2009, 2011.
W27	Eagle Creek	2007 - Date	7,100,997	458,235	2.7	1,037	Continuous discharge time-series, manual data only for 2007
W29	Haggart Creek below Eagle Creek	2007 - Date	7,099,583	458,225	86.1	1,112	Manual measurements for 2010, continuous data thereafter; station destroyed by freshet flooding and moved to W99
W99	Haggart Creek upstream of 15 Pup	2019	7,098,180	458,322	TBD	TBD	

**Table 3.4-2: Summary of Monthly Average Discharge, Unit Yield and Runoff for Project Site**

Station (Discharge Area)	Variable	Jan	Feb	Mar	Apr	May	Jun	Jul	Aug	Sep	Oct	Nov	Dec	Average/ Total
W1 (6.8 km <sup>2</sup> )	Average Discharge (m <sup>3</sup> /s)	--	--	--	0.024	0.218	0.099	0.086	0.089	0.091	0.090	0.069	--	0.096
	Average Yield (L/s/km <sup>2</sup> )	--	--	--	3.5	32.0	14.5	12.6	13.1	13.4	13.2	10.1	--	14.1
	Runoff (mm)	--	--	--	5	64	34	34	32	35	21	4	--	229
W4 (76.9 km <sup>2</sup> )	Average Discharge (m <sup>3</sup> /s)	--	--	--	0.256	2.022	1.022	0.819	0.871	0.891	0.794	1.026	--	0.963
	Average Yield (L/s/km <sup>2</sup> )	--	--	--	3.3	26.3	13.3	10.6	11.3	11.6	10.3	13.3	--	12.5
	Runoff (mm)	--	--	--	2	53	31	29	29	30	18	24	--	216
W5 (97.5 km <sup>2</sup> )	Average Discharge (m <sup>3</sup> /s)	--	--	--	--	2.960	1.375	1.034	1.029	1.020	1.009	--	--	1.405
	Average Yield (L/s/km <sup>2</sup> )	--	--	--	--	30.4	14.1	10.6	10.6	10.5	10.4	--	--	14.4
	Runoff (mm)	--	--	--	--	63	32	28	27	27	15	--	--	192
W6 (100.9 km <sup>2</sup> )	Average Discharge (m <sup>3</sup> /s)	--	--	--	--	3.240	1.204	0.949	1.126	1.193	0.985	1.300	--	1.428
	Average Yield (L/s/km <sup>2</sup> )	--	--	--	--	32.1	11.9	9.4	11.2	11.8	9.8	12.9	--	14.2

Station (Discharge Area)	Variable	Jan	Feb	Mar	Apr	May	Jun	Jul	Aug	Sep	Oct	Nov	Dec	Average/ Total
	Runoff (mm)	--	--	--	--	62	22	24	29	30	16	3	--	188
W22 (66.8 km <sup>2</sup> )	Average Discharge (m <sup>3</sup> /s)	--	--	--	0.609	1.898	0.881	0.683	0.803	0.784	0.701	0.937	--	0.912
	Average Yield (L/s/km <sup>2</sup> )	--	--	--	9.1	28.4	13.2	10.2	12.0	11.7	10.5	14.0	--	13.7
	Runoff (mm)	--	--	--	13	58	32	25	31	30	17	15	--	222
W26 (1.3 km <sup>2</sup> )	Average Discharge (m <sup>3</sup> /s)	--	--	--	--	0.018	0.017	0.014	0.014	0.013	0.010	--	--	0.014
	Average Yield (L/s/km <sup>2</sup> )	--	--	--	--	14.0	12.9	10.6	11.0	9.6	7.4	--	--	10.9
	Runoff (mm)	--	--	--	--	11	24	24	29	24	7	--	--	120
W27 (2.7 km <sup>2</sup> )	Average Discharge (m <sup>3</sup> /s)	--	--	--	--	0.080	0.034	0.029	0.025	0.024	0.025	--	--	0.036
	Average Yield (L/s/km <sup>2</sup> )	--	--	--	--	29.6	12.6	10.8	9.1	8.9	9.1	--	--	13.3
	Runoff (mm)	--	--	--	--	48	30	24	23	22	12	--	--	159
W29 (8 km <sup>2</sup> )	Average Discharge (m <sup>3</sup> /s)	--	--	--	--	2.508	1.300	1.224	1.165	1.043	0.980	--	--	1.370
	Average Yield (L/s/km <sup>2</sup> )	--	--	--	--	29.1	15.1	14.2	13.5	12.1	11.4	--	--	15.9
	Runoff (mm)	--	--	--	--	44	27	38	35	31	20	--	--	196

Source: Lorax (2019b)

### 3.4.2 Surface Water Quality

The current water quality and aquatic biota baseline program began in 2007. Stantec (2011a and 2012a), Lorax (2013), and Lorax (2017b) provide details on sample locations, sampling methods and frequency, and detailed summaries of results. Water quality characterization has occurred every year since 2007 and is still ongoing. The water quality data summaries provided in the subsection below reflect baseline conditions prior to construction.

The study area includes the Haggart Creek, Dublin Gulch, Eagle Creek basins, which have been subject to historical placer mining. Dublin Gulch and Eagle Creek basins have been affected by further development activities due to mine construction. The study area also includes Lynx Creek basin, which has not been subject to placer mining and will be unaffected by development activities. For the period of 2007 to 2016, a total of 21 monitoring stations were sampled within the study area. Monitoring of these stations continued during construction (2017-2019) and will continue during operations as part of the Environmental Monitoring, Surveillance and Adaptive Management Plan (EMSAMP). Since this data does not represent baseline conditions it is not reported on in this section, but is reported on in our monthly and annual reports submitted to the Yukon Water Board. The baseline data were used to establish water quality objectives and adaptive management criteria.

Portions of Haggart Creek, Dublin Gulch, and Eagle Creek drainage basins are located upstream, within or downstream of Project activities, thus sampling sites were located upstream and downstream of the Project footprint. Lynx Creek drains a large catchment to the south of the Project area that will be unaffected by development activities and will serve as reference monitoring location, but because it will be unaffected it is not summarized in this management plan.

#### 3.4.2.1 Dublin Gulch Drainage

The major ion chemistry of Dublin Gulch is assessed with respect to conductivity, hardness, alkalinity, sulphate and pH. Dublin Gulch is characterized by soft to moderately hard waters, with monthly mean hardness values

ranging from 28 to 66 mg/L at station W1 (downstream) and 47 mg/L to 145 mg/L at station W21 (upstream). Values for conductivity, hardness, and alkalinity demonstrate pronounced seasonal fluctuations, with minima coinciding with freshet periods in May and June. Conductivity, hardness and alkalinity at both sites exhibit an approximate two- to three-fold increase in concentration between freshet and other times of the year.

Overall, such trends in stream salinity reflect varying proportions of snow-melt driven surface runoff (lower ionic strength) and groundwater inputs (higher ionic strength) as driven by the seasonal water balance. Values upstream are typically higher than values downstream, and may reflect the contribution from groundwater discharges at lower elevations in the catchment.

The pH in Dublin Gulch remains relatively uniform throughout the year with values generally ranging between 7.0 and 8.0. The neutral to slightly basic pH conditions can be linked to bicarbonate alkalinity. All pH values reported to date have remained within the BC freshwater chronic criterion range for pH of 6.5 to 8.5.

Baseline concentrations for sulphate in Dublin Gulch are generally low, and exhibit a pronounced seasonal signature as observed for other salinity proxies. Sulphate minima during high flow can be attributed to the influence of low ionic strength melt waters, while higher values during the low-flow periods likely reflect an increased proportion of groundwater inputs.

Mean monthly sulphate values range from freshet minima of approximately 6.0 mg/L and 17 mg/L, respectively to maximum mean values observed during winter low flows of 20 mg/L and 65 mg/L, respectively.).

Unlike the dissolved ions, elevated TSS concentrations in Dublin Gulch generally coincide with the peak snowmelt month of May or during intense rainfall events. At most other flow periods of the year, TSS values in Dublin Gulch were generally below the analytical detection limit of 3.0 mg/L. Peak TSS values measured for the period of 2007 to 2016 were 103 mg/L (May 2014) and 37 mg/L (May 2011), respectively.

Nutrients quantified in Dublin Gulch include nitrate (NO<sub>3</sub><sup>-</sup>), nitrite (NO<sub>2</sub><sup>-</sup>), ammonia (NH<sub>3</sub>), total phosphate (T-PO<sub>43</sub><sup>-</sup>), and dissolved orthophosphate (D-o-PO<sub>43</sub><sup>-</sup>). In overview, nutrient parameters show low values in Dublin Gulch. Ammonia-N concentrations in Dublin Gulch are low with mean monthly values ranging from <0.005 mg/L to 0.028 mg/L.

Ammonia-N concentrations are expected to remain low in Dublin Gulch due to the low persistence of ammonia in fully oxygenated freshwaters at neutral pH. Similar to ammonia, the majority of nitrite-N values have occurred near or below the detection limit value. Baseline nitrate-N concentrations in Dublin Gulch are also low, with mean monthly values ranging from approximately 0.006 to 0.2 mg/L. Minima are evident during high flow periods, reflecting melt water influences. During lower flow periods, Dublin Gulch is characterized by higher nitrate-N concentrations, again likely reflective of a greater proportion of groundwater derived flow.

Primary productivity in freshwaters is typically limited by available phosphorus. Accordingly, measurements of phosphorus compounds in surface waters can provide an indication of trophic status (i.e., productivity regime). Baseline concentrations for dissolved orthophosphate in Dublin Gulch are low, ranging from approximately <0.0020 to 0.005 mg/L.

Total organic carbon (TOC) reflects a combination of dissolved organic carbon (DOC) and particulate phases associated with both aquatic and terrestrial organic matter. Highest values of TOC and DOC are typically observed during high flow periods, likely reflecting contributions of particulate carbon associated with terrestrial runoff and within-stream re-suspension. In contrast, low and uniform values prevail during low flow conditions, during which time TOC is predicted to be present primarily as dissolved phases. Mean monthly baseflow TOC

levels in Dublin Gulch are lowest at W1 (1.0 mg/L) and slightly higher at W21 (1.4 mg/L). Freshet flow TOC levels are higher and typically exceed 10 mg/L.

Baseline trace element concentrations in Dublin Gulch were derived from data collected from August 2007 to July 2016. In general, mean monthly concentrations of total and dissolved trace elements are low (e.g., Sb, Cu, Co, Cr, Pb, Hg, Se, Tl and Zn). However, Dublin Gulch is characterized by elevated total and dissolved As concentrations throughout its reaches with generally low variability in measured concentrations throughout all flow conditions.

Total Al and total Cd are also observed to be elevated during peak flow months; higher total concentrations are associated with elevated TSS levels. Total and dissolved Al values correlate positively with flow and elevated TSS, with dissolved Al reaching a mean monthly maximum of 0.15 mg/L at W1 to 0.17 mg/L at W21 in May. The correlation between dissolved and total fractions strongly suggests that the dissolved Al fraction is governed by colloidal Al hydroxides that are able to pass through a 0.45 µm filter membrane. During non-peak flow periods, dissolved Al concentrations in Dublin Gulch are typically an order of magnitude lower than total concentrations.

### 3.4.2.2 Eagle Creek Drainage

The major ion chemistry of Eagle Pup and Eagle Creek is described with respect to conductivity, hardness, alkalinity, sulphate and pH. Eagle Pup is characterized by moderately hard to hard waters, with monthly mean hardness values ranging from 94 to 285 mg/L. Hardness values in lower Eagle Creek are slightly lower but are characterized as moderately hard to hard with monthly mean hardness ranging from 83 mg/L to 212 mg/L at station.

Like the other project area streams, values for conductivity, hardness, and alkalinity demonstrate pronounced seasonal fluctuations, with minima coinciding with freshet periods in May and June during peak periods of snowmelt runoff. The pH in Eagle Creek remains relatively uniform throughout the year, with values generally ranging between 7.5 and 8.4. Alkalinity values in excess of 150 mg/L are typical and represent significant buffering capacity and dissolution of carbonate mineral phases in the catchment.

Baseline concentrations for sulphate in Eagle Creek are notably higher (e.g., ~60 mg/L during nonfreshet flow conditions) than observed in Dublin Gulch (~20 mg/L) for corresponding flow periods. The higher sulphate concentrations in the Eagle Creek drainage likely reflect the presence and weathering of the low-sulphide Eagle Gold deposit.

TSS concentrations observed in the Eagle Creek drainage were highly variable depending upon location in the catchment. The seasonal TSS signature was similar to that observed in Dublin Gulch, exhibiting higher concentrations in peak freshet months (e.g. > 30 mg/L) and lower concentrations during lower flow periods. Conversely, the highest mean monthly TSS concentrations corresponded to freshet (April/May) as well as summer (e.g. July and August) flow periods. The elevated TSS concentrations in Eagle Creek at station W27 had a significant influence on total trace element concentrations as described below.

Nutrient parameters show low values in the Eagle Creek drainage. Ammonia-N concentrations are low with mean monthly values ranging from <0.005 mg/L to 0.011 mg/L at W9 and <0.005 mg/L to 0.059 mg/L at W27. The majority of nitrite-N values have occurred near or below the detection limit value. Baseline nitrate-N concentrations during low flows in Eagle Creek are higher (e.g. ~0.02 to 0.30 mg/L) than observed in Dublin Gulch (e.g. 0.1 mg/L).

Baseline concentrations for dissolved orthophosphate in Eagle Creek are low, ranging from approximately <0.0020 to 0.005 mg/L. Mean monthly baseflow TOC levels in Eagle Creek are typically 1.0 mg/L to 2.0 mg/L, while freshet flow TOC levels are on the order of 15 to 20 mg/L.

Baseline trace element concentrations in upper Eagle Creek were derived from data collected from July 2009 to May 2013. Characterization of baseline water quality in lower Eagle Creek was developed using data collected from August 2007 to October 2014. Because of the influence of Suttles Gulch, the data from W9 and W27 are described separately below.

### **Upper Eagle Creek (Eagle Pup)**

In general, mean monthly concentrations of total and dissolved trace elements in the upper Eagle Creek basin are low, with concentrations of key parameters of interest (e.g. Cd, Cu, Co, Cr, Pb, Hg, Ni, Se, Tl and Zn) measured at, or below, their respective analytical detection limit. However, total and dissolved arsenic concentrations are naturally elevated in the head waters of Eagle Creek. During low flow conditions, total and dissolved As concentrations are similar and typically range between 0.018 mg/L and 0.022 mg/L with dissolved As accounting for over 95% of total As.

Episodic periods of higher flow and elevated TSS values result in elevated total As values that have been observed to range from approximately 0.033 mg/L to values approaching 0.06 mg/L. These brief periods of elevated total As do not translate into higher dissolved As concentrations which show decreased dissolved As concentrations during freshet months (e.g. 0.012 mg/L) and near consistent low flow dissolved concentrations of approximately 0.02 mg/L. The dissolved data suggest that solid-phase As associated with higher TSS is primarily responsible for peak concentrations observed. The periods of elevated TSS also result in higher concentrations of trace elements (namely Al, Cd, Mn and Ag).

### **Lower Eagle Creek**

Lower Eagle Creek has experienced periods of very elevated TSS since mid-2010 to present. These periods of elevated TSS result in elevated concentrations of total trace elements, in particular Al, As, Cd, Cu, Pb, Hg, Mn, Ni, Ag and Zn. Total As concentrations during these elevated TSS events can exceed 0.450 mg/L (and is directly attributable to solid-phase As in suspended sediments).

Conversely, dissolved As concentrations, while higher than observed in the upper reaches of Eagle Creek at W9, remain consistently between 0.025 mg/L and 0.036 mg/L (e.g. during winter low flow) and 0.03 and 0.049 mg/L during summer flow periods. Based on these results, baseflow As concentrations in upper Eagle Creek basin are approximately 0.02 mg/L and increase further down the catchment to roughly 0.028 mg/L.

### **3.4.2.3 Haggart Creek Drainage**

#### **Upper Haggart Creek above Dublin Gulch**

The major ion chemistry of upper Haggart Creek is described with respect to conductivity, hardness, alkalinity, sulphate and pH. Upper Haggart Creek is characterized by moderately hard to hard waters, with monthly mean hardness values ranging from approximately 63 to 216 mg/L. Like the other project area streams, values for conductivity, hardness, and alkalinity demonstrate pronounced seasonal fluctuations, with minima coinciding with freshet periods in May and June during peak periods of snowmelt-driven runoff. The pH in upper Haggart Creek remains relatively uniform throughout the year with mean values generally ranging between 7.3 and 8.0. Alkalinity

values are typically in excess of 85 mg/L suggesting a well-buffered system. Lower alkalinity values are only experienced during freshet periods.

Baseline concentrations for sulphate in upper Haggart Creek are notably higher (e.g., ~60 to 93 mg/L) during non-freshet flow conditions as compared to peak snowmelt periods where values typically less than 25 mg/L sulphate are observed. TSS concentrations in upper Haggart Creek exhibit freshet maxima, generally coinciding with the peak snowmelt month of May. At most other flow periods of the year, TSS values in upper Haggart Creek were generally below the analytical detection limit of 3.0 mg/L. The peak TSS value measured for the period of 2007 to 2016 was approximately 80 mg/L.

Nutrient parameters show low values in upper Haggart Creek. Ammonia-N concentrations are low with mean monthly values ranging from <0.005 mg/L to 0.022 mg/L at W22. Similar to ammonia, the majority of nitrite-N values have occurred near or below the detection limit value. Baseline nitrate-N concentrations in upper Haggart Creek are also low, with mean monthly values ranging from approximately 0.03 to 0.16 mg/L. Minima are evident during high flow periods, reflecting melt water influences.

Like other project area streams, baseline concentrations for dissolved orthophosphate in upper Haggart Creek are low, ranging from approximately <0.0010 to 0.0013 mg/L. Mean monthly baseflow TOC levels in upper Haggart Creek are low and generally less than 1.5 mg/L. Freshet flow TOC levels are much higher at approximately 25 mg/L, reflecting the addition of terrestrial-derived runoff and organic detritus.

In general, mean monthly concentrations of total and dissolved trace elements are low for all parameters monitored with the exception of Al, Mn and to a lesser extent Cd during the peak freshet month of May. Most parameters are present at concentrations at or below their respect analytical detection limit. Unlike Dublin Gulch and Eagle Creek drainages, arsenic concentrations in upper Haggart Creek at W22 are low; mean monthly concentrations range from a high of 0.004 mg/L during freshet periods to values typically less than 0.0008 mg/L for the remaining flow periods.

### **Upper Haggart Creek below Dublin Gulch**

The major ion chemistry of Haggart Creek downstream of Dublin Gulch at is similar to that observed at above Dublin Gulch with waters characterized as moderately hard to hard. Monthly mean hardness values range from approximately 56 to 209 mg/L with minima coinciding with freshet periods in May and June during snowmelt runoff. The pH is well buffered and relatively uniform throughout the year with values ranging between 7.3 and 8.0. Alkalinity values are lowest in the high flow periods (e.g. approximately 35 mg/L) and greatest in low flow periods (e.g. approximately 120 mg/L).

Sulphate concentrations are slightly lower than observed above Dublin Gulch as a result of the addition of low sulphate loadings from Dublin Gulch. The lowest sulphate concentrations are observed during May and June (e.g. 20 mg/L to 45 mg/L); higher sulphate concentrations are measured during non-freshet flow conditions (e.g. ~60 mg/L to ~90 mg/L).

TSS concentrations are similar to those observed above Dublin Gulch with the exception that higher TSS values below DG occur as a result of suspended solids loadings from Dublin Gulch during peak snowmelt months of May and June. At most other flow periods of the year, TSS values are generally below the analytical detection limit of 3.0 mg/L, with the exception of episodic summer rainfall events that increase suspended sediments loads in the Eagle Creek drainage and to a lesser extent in the Haggart Creek drainage.

Not surprisingly, nutrient parameters in Haggart Creek below Dublin Gulch are low with ammonia-N, nitrate-N and orthophosphate values being very similar in concentration to those observed in Haggart Creek above Dublin Gulch.

Trace element concentrations are very similar to those observed above Dublin Gulch with the sole exception of As. Specifically, mean monthly concentrations of total and dissolved trace elements are low for all parameters monitored with the exception of Al, Mn and to a lesser extent Cd during the peak freshet month of May. Arsenic concentrations are roughly four times that observed above Dublin Gulch. The reason for the increased As concentrations is due to significant natural As loadings entering from Dublin Gulch. Winter low flow mean monthly As concentrations range from 0.0013 mg/L to 0.0018 mg/L (December to March) to summer flow concentrations of approximately 0.0042 mg/L. 95th percentile values for total As for the same winter low flow and summer low flow conditions range from 0.0015 mg/L to 0.0025 mg/L and from 0.0044 mg/L to 0.0061 mg/L, respectively.

### **Haggart Creek below Eagle Creek**

Haggart Creek below Eagle Creek is characterized as moderately hard to hard water. Monthly mean hardness values range from approximately 67 to 232 mg/L with minima coinciding with freshet periods in May and June during snowmelt runoff. Hardness values and alkalinity are slightly higher in this location relative to upstream in Haggart Creek; the greater alkalinity and hardness in the section below Eagle Creek is a result of Ca, Mg inputs from Eagle Creek. The pH in Haggart Creek at below Eagle Creek is well buffered and relatively uniform throughout the year with values ranging between 7.4 and 8.1. Alkalinity values are lowest in the high flow periods (e.g. approximately 40 mg/L) and greatest during low flow periods (e.g. approximately 130 mg/L).

Sulphate concentrations are slightly higher than observed at the Haggart Creek segment below Dublin Gulch for the low flow months (e.g. January to April) and reflect higher sulphate loadings from Eagle Creek. During peak flow periods, sulphate concentrations in Haggart Creek from are not significantly different moving downstream and typically range from approximately 20 mg/L to 60 mg/L.

TSS concentrations are higher than those observed upstream during the peak flow periods and likely reflect the higher TSS loadings from Dublin Gulch and Eagle Creek. At most other flow periods of the year, TSS values are generally below the analytical detection limit of 3.0 mg/L with the exception of episodic summer rainfall events that increase suspended sediments loads in Haggart Creek sub-basins.

Nutrient parameters are low with ammonia-N, nitrate-N and orthophosphate values being very similar in concentration to those observed in Haggart Creek above Dublin Gulch.

Water quality in Eagle Creek has a notable influence on water quality conditions in Haggart Creek below Eagle Creek. The high TSS loadings occurring in Eagle Creek, particularly during freshet conditions, result in elevated concentrations of total trace elements, in particular Al, As, Cd, Cu, Pb, and Mn. The most significant trace metal increases are associated with total arsenic. Total As concentrations are typically greater below Eagle Creek as compared to above Dublin Gulch during most flow periods of the year and can be particularly elevated during peak flow events. As with the other trace metal parameters, the elevated total As concentrations can be associated with the increased TSS loadings derived from Eagle Creek.

Mean As concentrations were calculated using all monitoring results for each station. Mean arsenic concentrations in Haggart Creek above Dublin Gulch (0.0009 mg/L) increase to values of approximately 0.0038 mg/L downstream following inputs from Dublin Gulch. Below Eagle Creek, mean arsenic concentrations in Haggart Creek increase to values of approximately 0.006 mg/L. Farther downstream, mean arsenic concentrations decrease to values of roughly 0.0045 mg/L. Although Lynx Creek is an undisturbed catchment,



arsenic is also naturally elevated in drainage waters with a mean arsenic concentration of 0.0064 mg/L and as a result, mean arsenic concentrations below the confluence with Lynx Creek, are observed to increase to 0.0056 mg/L.

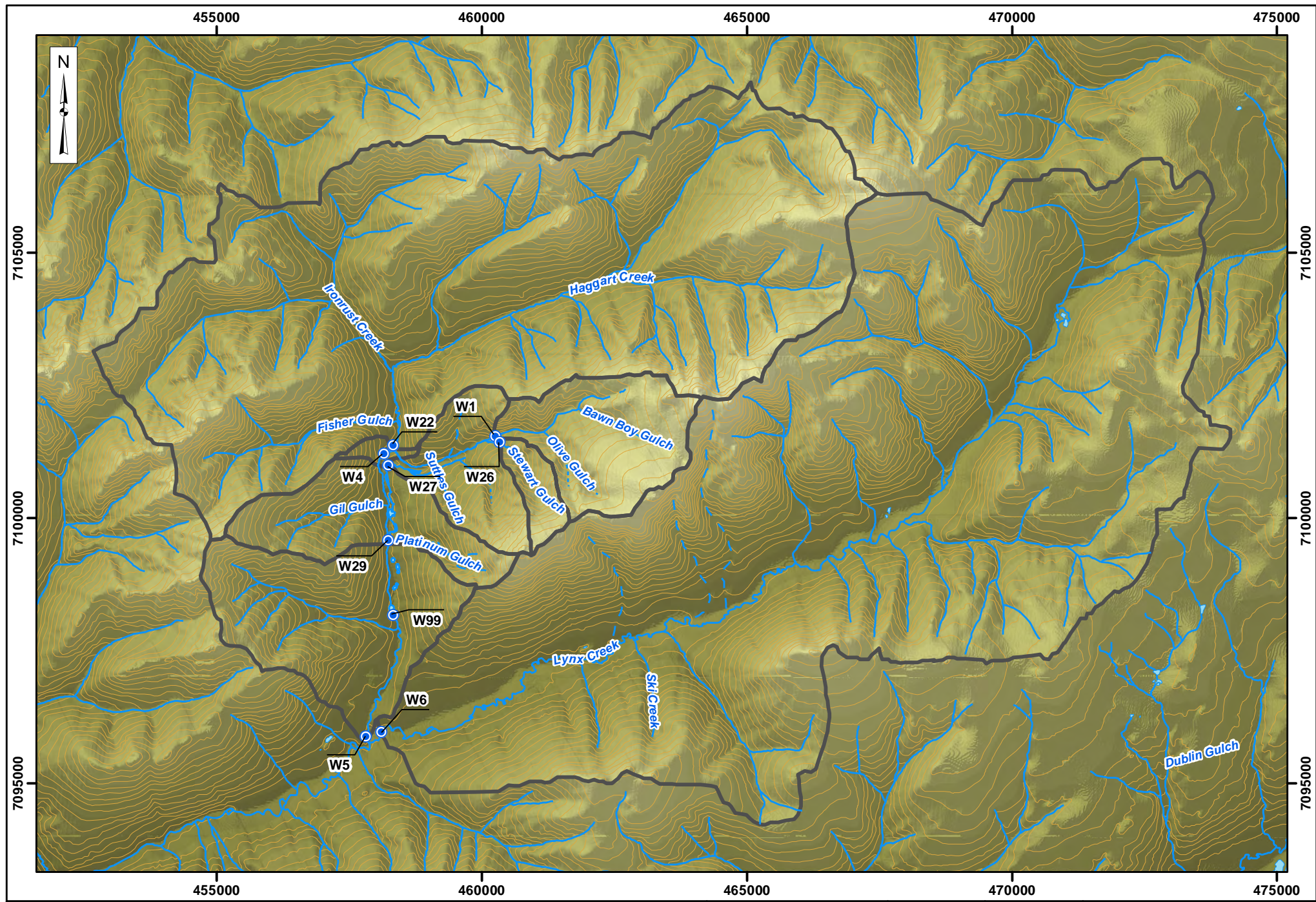

Legend:

	Watershed Boundary		Contour (100ft)		Ephemeral
	Perennial		Intermittent		

0 0.5 1 2  
Kilometers

Projection:  
NAD 83 UTM  
Zone 8N

Date:  
2020/01/10

Drawn By:  
HC

Figure:  
3.4-1

**EAGLE GOLD PROJECT  
YUKON TERRITORY**

**Hydrometric  
Station Network**

## 3.5 GROUNDWATER

Material property data available for the Project comprises results of packer tests, slug tests and pumping tests from drilled bore holes and wells at site. Hydraulic head data (instantaneous and continuous) has been collected from 104 monitoring wells, standpipe piezometers, vibrating wire piezometers, and aquifer test wells (Stantec 2010, BGC 2012a, BGC 2012b and BGC 2013a), located across eight different sub-basins that include Bawn Boy Gulch, Olive Gulch, Stewart Gulch, Eagle Pup, Suttles Gulch, Platinum Gulch, Dublin Gulch, and Ann Gulch. In addition, since 2009 water quality data has been collected on a regular basis from 18 of the site monitoring wells in these same sub-basins. The groundwater level and groundwater quality data collection program that began in 2009 is still on-going. The data obtained has been used to identify local groundwater recharge and discharge zones, groundwater flow patterns, characterize groundwater quality and to develop a numerical hydrogeological model (BGC 2014) which was recently updated (BGC 2019).

### 3.5.1 Hydrogeologic Setting

There are two principal water-bearing units in the project area: deeper relatively low permeability bedrock and the near-surface moderately permeable surficial deposits. Surficial material at the Project site consists of a thin veneer of organic soils underlain by colluvium (i.e., a loose heterogeneous mass of soil material), glaciofluvial deposits (i.e., originating from rivers associated with glaciers), or till (a glacial deposit). Below these clastic (i.e., transported broken fragments of rock) units are either metasedimentary or granodiorite bedrock, which is deeply weathered in places. The elongated granodiorite stock (ore bearing unit) has intruded the surrounding host metasediment. The surficial material thickness and physical properties varies significantly throughout the area.

The Dublin Gulch valley contains large amounts of fluvial materials that were considerably reworked by placer mining operations. Extensive stockpiles of placer deposits comprised of sub-rounded metasediment and granodiorite clasts, ranging in size from sands to boulders, and fine-grained material (i.e., that are located in former placer settling ponds) are present adjacent to the Dublin Gulch and Eagle Creek watercourses. A till blanket covered with a colluvial veneer is located along the south valley wall in Dublin Gulch valley and extends southward in the Haggart Creek valley. A recent alluvial fan is present where Dublin Gulch meets Haggart Creek. Discontinuous permafrost is also present, especially on the north-facing slopes and affects the connectivity between the deep and shallow water-bearing zones in places. Further details of the spatial distribution and characteristics of surficial materials are found in Stantec (2011b).

### 3.5.2 Groundwater Occurrence

Generally groundwater has been observed deeper (approximately >6 m below ground) at higher elevations and shallow to artesian in lower elevations and in valley bottoms. Springs and seeps have been observed in a few locations where valley bottoms have narrowed. These are typically associated with the re-emergence of a stream from channel deposits (i.e., a gaining reach). In these instances (e.g., Eagle Pup, Stewart Gulch), thin alluvium overlying shallow bedrock is the likely cause of the emergence. The interpreted piezometric surface appears to generally mimic the surface topography (see Figures 3 and 4 in BGC 2013a). Groundwater elevation data exhibit common seasonal trends in all monitored locations, characterized by relatively high-water levels corresponding to spring freshet and fall precipitation events, and relatively low water levels related to dry summer and frozen winter conditions. Small but discernible responses to precipitation events were observed in the wells with continuously recording dataloggers.

### 3.5.3 Groundwater Flow

Groundwater flow in the bedrock occurs in fractures and fault zones, while preferentially flowing through more permeable (and porous) sediments within the surficial deposits. General orientation of groundwater flow contours mimic the topography of the site as groundwater flows from the highest to lowest areas. Throughout most of the project area the groundwater divides of each sub-basin approximately coincide with the surface water divides. In the lower Dublin Gulch valley the groundwater divide between the Eagle Creek and Dublin Gulch basins in the placer tailings is not as clearly defined due to the disturbed nature of the placer deposits.

Groundwater recharge occurs at higher elevations throughout the Dublin Gulch-Eagle Creek drainage basin and ultimately discharges to surface water (in some cases as seeps and springs) at lower elevations in the valley or directly to surface streams, or ultimately into Haggart Creek. The main groundwater flow in conjunction with the highest groundwater elevations is expected to occur during the snowmelt in late spring (i.e., May to June) after thawing of the shallow sediment.

Data from nested well pairs or vibrating wire piezometer nests indicate upward or near neutral gradients in the lower Dublin Gulch valley and a mix of near neutral, downward and upward gradients in the upper reaches of Bawn Boy or in the Open Pit area. In some cases, gradient plots indicate both positive and negative gradients exist within the same profile, which may be due to anisotropy within the bedrock, and/or possible fracture controls on groundwater flow.

### 3.5.4 Surface Water - Groundwater Connectivity

Streamflow is generally composed of rainfall runoff and groundwater base flow. Groundwater contributes to stream flows where the groundwater table elevation intersects the ground surface. Typically, these intersections are located in stream channel invert (e.g., Eagle Pup appears in mid-valley where the valley is well confined by bedrock); however, they also appear as seepage from slopes within the placer deposits of the lower Dublin Gulch valley. Groundwater from the lower Dublin Gulch valley likely contributes a measurable portion of the baseflow to Haggart Creek. The baseflow contributions to the streams maintain flow in the larger creeks during the drier months of the year (including winter flows).

### 3.5.5 Groundwater Flow Properties

Estimates of hydraulic conductivity in the overburden materials are based on 12 recovery tests carried out in colluvium, till, placer, and fluvial materials and three pumping tests conducted in the lower Dublin Gulch valley aquifer. Results for all testing range from  $4 \times 10^{-7}$  to  $4 \times 10^{-3}$  metres per second (m/s) at depths less than 35 m below ground. The hydraulic conductivity of the colluvial, alluvial, and till deposits was generally higher than that of the placer material, and also higher than the bedrock.

The bedrock hydraulic conductivity dataset includes over 80 packer tests and recovery tests conducted in over 50 boreholes and six pumping tests. Results of the pumping tests are typically considered to be more representative of the larger scale (bulk) hydraulic conductivity of the rock mass. Results of the 1996 pumping tests conducted at depths less than 55 m yielded hydraulic conductivity values ranging from  $3 \times 10^{-7}$  m/s to  $5 \times 10^{-7}$  m/s. Mean results of the two pumping tests conducted in bedrock in 2011 were  $8 \times 10^{-6}$  m/s in the lower valley and  $9 \times 10^{-8}$  m/s in the Open Pit area at depths up to 100 m and 140 m below ground, respectively. Results from the 2012 testing in the lower Dublin Gulch valley bedrock aquifer are about an order of magnitude higher ( $9.0 \times 10^{-5}$  m/s) than results from 2011 testing; however, these results are specific to an 18 m thick zone targeted by the well, whereas the 2011 well was tested over a thicker (37 m) zone.

Generally, the hydraulic conductivity of the intrusive units and metasediments is similar and tends to decrease with depth, although considerable variation in results is apparent for each unit at any given depth. The general trend of decreasing hydraulic conductivity is common in bedrock settings as described by Rutqvist and Stephansson (2003).

### 3.5.6 Groundwater Quality

#### 3.5.6.1 General Characterization

Groundwater quality data has been previously summarized in Stantec (2012b), which includes the most comprehensive data summary of 1996-2011 data, and BGC (2013a) which provides an update through 2012. The data suggests that the chemical composition of groundwater in the project area depends on the local and up-gradient rock-types. Groundwater quality data have been collected for many areas of the site including in Eagle Pup, Dublin, Suttles, Ann, Stewart, Olive, Bawn Boy and Platinum Gulches. The parameters analyzed included dissolved and total metals, nutrients, anions and other general parameters.

The groundwater samples were classified based on their major ion chemical composition, taking into account the major anions and cations. Calcium is the dominating cation in most groundwater samples from the site; however, in some sampling locations magnesium concentrations exceeded calcium. Carbonate was the dominating anion in all samples, and was particularly high in some samples.

The following parameters exceeded the Canadian Council of Ministers for the Environment (CCME) and/or Contaminated Sites Regulation (CSR) guidance parameters in the Project area: aluminum, arsenic, cadmium, copper, iron, lead, molybdenum, nickel, selenium, silver, and/or zinc. The CSR guideline values apply to both surface and groundwater, whereas the CCME guidelines only apply to surface water. However, as groundwater ultimately discharges to surface water bodies, the CCME guideline values are included here for reference.

Comparison of groundwater quality data to current Yukon CSR AW standards (for protection of freshwater aquatic life) identified dissolved arsenic exceedances in all Project sub basins. Arsenic concentrations in Ann Gulch, Suttles Gulch and Eagle Pup were 3 to 70 times higher than the CSR AW standard; whereas, arsenic concentrations in Platinum Gulch were 160 to 200 times higher than the CSR AW standard.

The highest dissolved arsenic concentrations reported in the project area occurred consistently in Platinum Gulch and ranged between 8 and 10 mg/L. These concentrations were approximately two times higher than dissolved arsenic values reported in a well in Dublin Gulch and approximately ten to one hundred times higher than concentrations reported in all other project sub-basins. No discernible correlations were interpreted between dissolved metals and geological strata. CSR AW dissolved arsenic exceedances were reported in monitoring wells screened in both unconsolidated sediments and bedrock.

The exceedances do not imply that the groundwater at the site is currently contaminated; only that background concentrations of these parameters are higher than typically found in other natural sites in Canada and merely reflect the natural geologic and hydrogeologic conditions within these specific areas of the project area.

Comparison of the multiple years of groundwater data indicated that groundwater quality parameters were generally in the same range and that seasonal trends were not apparent over the years sampled.

### **3.5.6.2 Statistical Characterization**

A comprehensive characterization of background groundwater quality was completed by CoreGeo/Watterson (2017) in accordance with Clause 158 of QZ14-041. The assessment included a statistical analysis of all available groundwater quality data from the Project area up through 2015. In keeping with the rationale described within the Reasons for Decision document issued for QZ14-041, and the methods described within CSR Protocol No. 10, background groundwater quality values at the 95th percentile were determined. Also, to help characterize the data across the site, groundwater quality data are presented and described by sub-basin and on a site-wide basis.

The following points summarize the results and conclusions of the statistical characterization:

- The quality and character of groundwater data (in terms of spatial coverage, multiple sampling events over a range of seasons and times of the year, consistency in sampling technique and analytical laboratory) meets or exceeds the requirements established in Protocol No. 10, where applicable.
- Stantec (2012b) and BGC (2013a) concluded that, in general, there were no discernible effects from well completion zone or seasonality in the data.
- Background concentration calculation and presentation methods are intended to illustrate groundwater quality variation at the site and to provide a baseline for future evaluation of groundwater data.
- Background POI concentrations (95th percentiles) demonstrated a high degree of spatial variability at the sub-basin and site-wide scales.
- Except for cyanide during the 1995-96 sampling events, the site-wide background concentrations of all general chemistry parameters did not exceed applicable CCME-FAL guideline values for these parameters.
- Although site-wide background calculations may provide a useful overall reference, significant variation in background concentrations between sub-basins for some elements indicates that the site-wide background values may not be the best representative value in all situations.
- A comparison between total and dissolved background concentrations demonstrated the role that turbidity and TSS has on the overall sample results, especially when TSS is greater than 100 NTU for the common rock forming elements (i.e., aluminum, iron). For the most part, total water chemistry data was suitable to support background parameter calculations; however, where wells produce samples with elevated turbidity or TSS, dissolved parameters may provide a better comparison with guidelines especially with respect to toxicity for aquatic life.

## 4 DESIGN BASIS AND CRITERIA

### 4.1 STORM WATER DESIGN CRITERIA

For the purpose of this Plan, the Project area has been subdivided into a number of hydrologic watersheds and sub-watersheds, as shown on Figure 4.1-1. These watershed boundaries shown in the figure are based on the proposed end of mine topography. To ensure that the corresponding conveyance and storage structures are capable of routing runoff during the entire life of the Project, they were sized to their largest respective contributing area.

A risk-based approach was used to select appropriate design storm events for water management facilities. This approach weighs the likelihood of failure, versus the consequence of failure, on a case-specific basis. Design storm events are developed by assessing the annual recurrence of precipitation events of a given magnitude, as described in Section 3.

Design storm events were used as input parameters in most rainfall-runoff type storm water models (e.g., HEC-HMS, PCSWMM and, TR-55). Design criteria for various design elements are listed in Table 4.1-1.

**Table 4.1-1: Design Criteria**

Infrastructure Element	Design Element	Design Basis Criteria
Unlined Diversion or Collection Ditches	Design Storm Event	1 in 10-year, 24-hour for capacity and 1 in 100-year for armouring
	Maximum Depth (mm): Type 1 or 2	300
	Minimum Width (mm): Type 2	500
	Minimum Grade (%): Type 1 or 2	1.00
	Maximum Grade (%): Type 1 or 2	1.70
	Maximum Side Slopes: Type 1 or 2	3H:1V
	Maximum Velocity (m/s): Type 1 or 2	1.5
Lined Diversion or Collection Ditches	Design Storm Event	1 in 10-year, 24-hour for capacity and 1 in 100-year for armouring
	Design Storm Event (above major infrastructure)	1 in 100-year
	Maximum Depth (mm)	500
	Minimum Grade (%): Type 3 / Type 4	1.00 / 0.50
	Maximum Grade (%): Type 3 / Type 4	4.5 / 15
	Maximum Side Slopes: Type 3 / Type 4	2.5H:1V / 1H:1V

Section 4 Design Basis and Criteria

Infrastructure Element	Design Element	Design Basis Criteria
	Maximum Velocity (m/s): Type 3 / Type 4	2.33 / 4.0
Pipes	Design Storm Event	1 in 10-year, 24-hour
Culverts	Minimum Diameter (mm)	750
	Design Storm Event (Areas < 1 ha)	1 in 10-year, 24-hour
	Design Storm Event (Areas > 1 ha)	1 in 100-year, 24-hour
	Design Storm Event (at stream conveyances)	1 in 200-year, 24-hour
	Design Storm Event (downstream of the Lower Dublin South Pond)	1 in 1000-year, 24-hour
	Maximum HW/Diameter Ratio	2.0 for less than 1.0 m 1.5 for greater than 1.0 m
	Minimum Grade (%)	0.5
	Minimum Velocity (m/s)	1.0
	Maximum Velocity (m/s)	4.0
Temporary Sediment Control Ponds and Exfiltration Areas	Design Storm Event (storage)	1 in 10-year, 24-hour
	Design Storm Event (overflow spillway)	1 in 100-year, 24-hour
	Depth Requirements (m):	
	Minimum Dead Storage (sediment)	0.5
	Maximum Dead Storage (sediment)	50% of Total Depth
	Minimum Live Storage (liquid)	1.5
Permanent Sediment Control Ponds	Design Storm Event (storage)	1 in 10-year, 24-hour
	Design Storm Event (overflow spillway)	1 in 200-year, 24-hour
	Design Storm Event (overflow spillway – dam)	1 in 1000-year, 24-hour
	Depth Requirements (m):	
	Minimum Dead Storage (sediment)	0.5
	Maximum Dead Storage (sediment)	50% of Total Depth



Infrastructure Element	Design Element	Design Basis Criteria
	Minimum Live Storage (liquid)	1.5
	Minimum Freeboard (200-year event)	0.5
	Dewatering (pumping capability)	Full Dewater in 24 hours

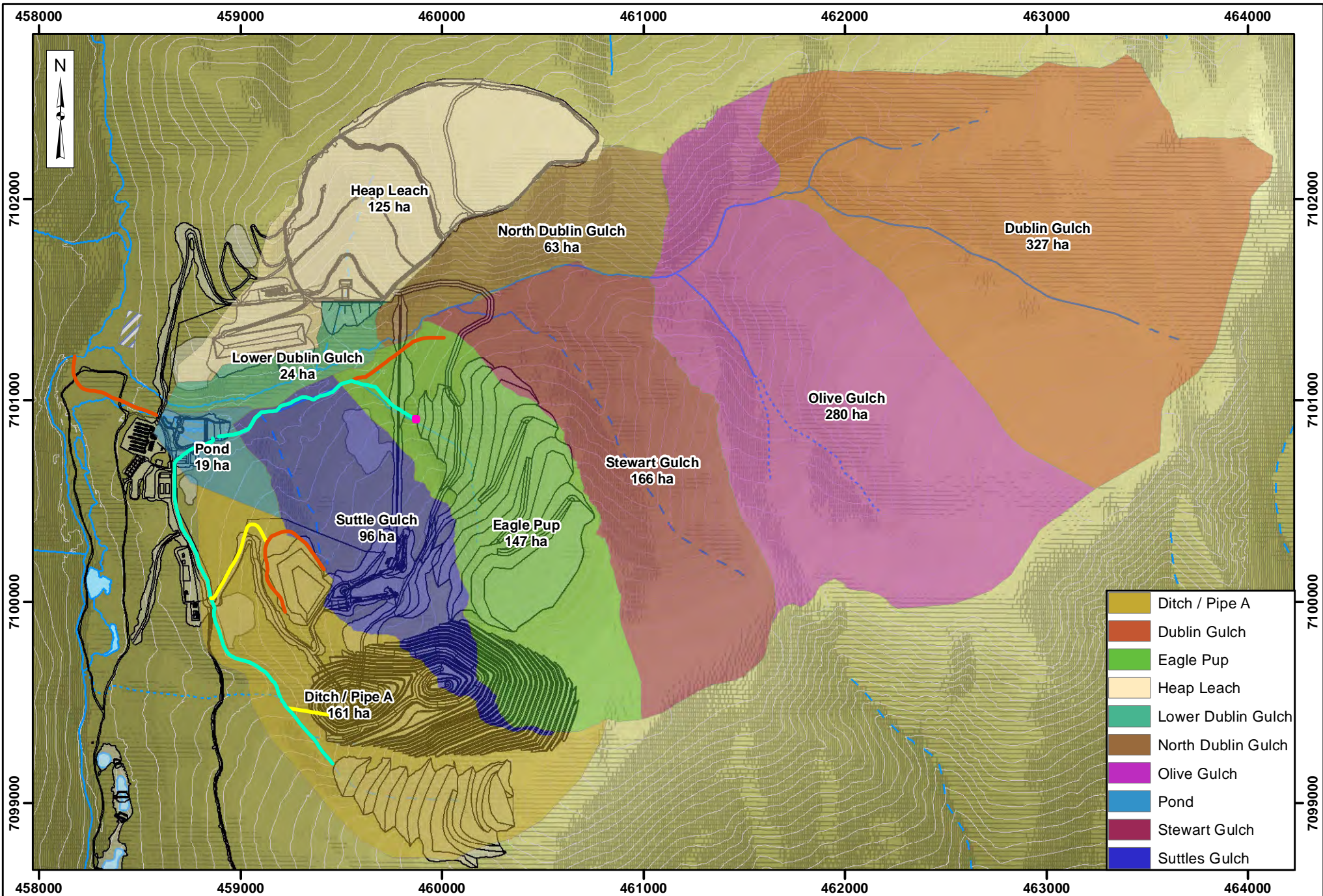

Legend:

Facility	Ditch	Perennial
Contour (25 m)	Pipe & Ditch	Ephemeral
Reserved Area	Pipe	Intermittent

StrataGold Corporation

0 175 350 700  
Metres

Projection: NAD 83 UTM Zone 8N	Drawn By: HC
Date: 2020/01/10	Figure: 4.1-1

**EAGLE GOLD PROJECT  
YUKON TERRITORY**

**Overview Plan  
Watershed Areas**

## 4.2 SEDIMENT AND CONTROL EROSION

Sediment and erosion control measures are implemented and maintained to prevent the discharge of sediment-laden water to the receiving environment. The BMPs described below are shown on Figure 4.2-1 to Figure 4.2-3 and were utilized during construction and will continue to be required during operations. Implementation of BMPs is described in Section 6.

### 4.2.1 Sediment and Erosion Sources

Activities that have the potential to result in erosion and sedimentation include the following.

- Vegetation clearing and topsoil stripping.
- Excavation, grading and filling.
- Stockpiling of topsoil and waste rock.
- Management of ice-rich material.
- Construction and maintenance of roads and infrastructure.

Potential effects from the above activities in the absence of planned mitigation measures include:

- Increased surface erosion from disturbed and rehabilitated areas
- Increased sediment load entering the natural water system
- Siltation or erosion of ditches, culverts, and watercourses
- Damage to existing roadways and embankments, i.e. rutting, scouring, or potholing

The Plan addresses the above potential hazards to ensure effective management of surface water and sediment-laden runoff. Sediment mobilization and erosion can best be minimized by using the following measures.

- Limiting the extent of land disturbance to the practical minimum
- Reducing water velocities across the ground using soil bioengineering, surface roughening, sediment logs, and re-contouring, particularly on exposed surfaces and in areas where water concentrates
- Concurrently reseeding disturbed land and constructing drainage controls to improve the stability of rehabilitated land
- Protecting natural drainages and watercourses by constructing appropriate sediment control devices such as collection and diversion ditches, sediment traps, in-channel energy dissipaters, and sediment basins
- Installing rock riprap, channel lining, sediment filters or other suitable measures in ditches on steep gradients, as required
- Restricting access to re-vegetated and stabilized areas
- Constructing collection and diversion ditches to intercept surface runoff

- Directing all sediment-laden runoff to the appropriate sediment control measure
- Constructing appropriate temporary BMP measures (e.g., silt fences, hay bales) downslope of disturbed sites (where more permanent sediment control measures are not appropriate, or in combination with more permanent measures)
- Implementing soil bioengineering techniques to contain sediment and enable disturbed surfaces to recover.

Installation of temporary erosion and sediment control features or “BMPs” is the first step towards controlling erosion and sedimentation. All temporary sediment and erosion control features will require regular maintenance and inspection after each significant rainfall. These temporary features will be removed after achieving soil and sediment stabilization. Typical sediment and erosion design elements and BMPs are described in the following section.

## **4.2.2 Best Management Practices**

Erosion control BMPs reduce erosion by stabilizing exposed soil or reducing surface runoff flow velocity. There are generally two types of erosion control BMPs:

- Source control BMPs for protection of exposed surfaces, and
- Conveyance BMPs for control of runoff and reduction/capture of sediment.

Descriptions of the planned BMPs are provided below.

### **4.2.2.1 Vegetation Management**

Natural vegetation is one of the best and most cost-effective methods of reducing the potential for erosion and sedimentation. Vegetation keeps soil secure, and leaves and ground cover absorb raindrop velocities. In order to preserve vegetation, “no-entry” vegetation buffers are utilized to prevent excess clearing, particularly around water bodies, prior to clearing vegetation from surrounding areas. When preserving natural vegetation is not a viable option, cleared areas that will not include infrastructure will be re-seeded as soon as practical.

### **4.2.2.2 Soil Bioengineering**

Soil bioengineering is the use of plant materials to perform engineering functions such as bank protection, erosion protection, drainage, and slope stabilization (Polster 2002). Some typical techniques include:

- Sediment log fences
- Live bank protection
- Live palisades

Sediment log fences are used on over-steepened slopes where the incline prevents successful growth of vegetation. Sediment logs are placed on the slopes to create terraces, which slows the velocity of water, and holds the soil in place in order to encourage vegetation growth.

Live bank protection is generally used in streams for habitat restoration, but the technique can be transferred to constructed ditches. Sediment log fences using cut plugs and live cuttings are installed on the banks of the ditch, which become stabilized once the live cuttings sprout and grow.

The live palisades technique involves installing large cottonwood (poplar) posts in trenches adjacent to eroding stream beds where the natural vegetation has been compromised. The cottonwood will root along its entire buried length producing a dense cylinder of roots.

These techniques prevent the creation of smooth, hard surfaces, which tend to encourage increased velocities and thus increased erosion potential. USDA (1992) provides useful application and construction guidelines for various bioengineering techniques.

#### **4.2.2.3 Mulching**

Mulching is the application of a uniform protective layer of straw, wood fiber, wood chips, or other acceptable material on, or incorporated into, the soil surface of a seeded area to allow for the immediate protection of the seed bed. The purpose of mulching is to protect the soil surface from the forces of raindrop impact and overland flow, foster the growth of vegetation, increase infiltration, reduce evaporation, insulate the soil, and suppress weed growth. Mulching also helps hold fertilizer, seed, and topsoil in place in the presence of wind, rain, and runoff, while reducing the need for watering. Mulching has been used to minimize permafrost thaw and to restore physical stability in some disturbed areas.

Mulching may also be utilized in areas that have been seeded either for temporary or permanent covers. There are two basic types of mulches: organic mulches and chemical mulches. Organic mulches may include straw, hay, wood fiber, wood chips and bark chips. This type of mulch is usually spread by hand or by machine (mulch blower) after seed, water, and fertilizer have been applied. Chemical mulches, also known as soil binders or tackifiers, are composed of a variety of synthetic materials, including emulsions or dispersions of vinyl compounds, rubber, asphalt, or plastics mixed with water. Chemical mulches are usually mixed with organic mulches as a tacking agent to aid in the stabilization process, and are not used as stand-alone mulch, except in cases where temporary dust and/or erosion control is required.

Hydroseeding, sometimes referred to as hydromulching, consists of mixing a tackifier, specified organic mulch, seed, water, and fertilizer together in a hydrosurry and spraying a layer of the mixture onto a surface or slope with hydraulic application equipment. The choice of materials for mulching will be based on soil conditions, season, type of vegetation, and the size of the area.

#### **4.2.2.4 Rolled Erosion Control Products**

Rolled erosion control products (RECP) are geosynthetic or organic materials composed of two layers of coarse mesh that contain a central layer of permeable fibers in between. These products take the form of flexible sheet materials that are often composed of organic materials that decompose over time. When intended for long-term use, RECPs are made from UV-stable synthetics such as polypropylene. RECPs may be used to cover un-vegetated cut or fill slopes in order to provide erosion control when seeding or mulching alone is unsuccessful. RECP sheets must be anchored with special stakes or rocks and must be in direct, tight contact with the soil surface in order to perform effectively. RECP's have been used sparingly in specific areas to date.

#### **4.2.2.5 Surface Roughening**

Cut and fill slopes are typically roughened with tracked machinery or by other means, to reduce runoff velocity, increase infiltration, reduce erosion, and to aid in the establishment of vegetative cover. Roughening is typically carried out by a tracked machine moving up and down the slope, creating undulations on the soil surface parallel to the contour. This procedure is simple, inexpensive and provides immediate short-term erosion control for bare soil, where vegetative cover is not yet established. Compared to hard, compacted smooth surfaces a rough soil surface provides more favorable moisture conditions, which will aid in seed germination. Surface roughening works best on flat and moderately sloped areas.

#### **4.2.2.6 Re-contouring**

Re-contouring the soil surface can also reduce the effect of erosion by shortening the length of the accumulation and movement of water as well as decreasing its slope. Creating undulations or troughs also reduces overland water movement velocity. These types of improvements are beneficial as they are easily planned and constructed on site. However, where implemented both surface roughening and re-contouring are considered only semi-permanent erosion control methods and more permanent structures will be needed over time.

#### **4.2.2.7 Silt Fencing**

Silt fencing is a perimeter control used to intercept sheet flow runoff and used in conjunction with other BMPs. Typical silt fencing comprises a geotextile fabric anchored to posts driven into the ground. Silt fencing promotes sediment control by filtering water that passes through the fabric and increases short term detention time, allowing suspended sediments to settle. A typical silt fence installation is shown on Figure 4.2-1.

Silt fences have been placed parallel to slope contours in key areas. Barrier locations were chosen based on site features and conditions (e.g., soil types, terrain features, and sensitive areas), design plans, existing and anticipated drainage courses, and other available erosion and sediment controls. Typical barrier sites are catch points beyond the toe of fill or on side slopes above waterways or drainage channels. Silt fences have not been used for wide low-flow, low-velocity drainage ways, for concentrated flows, in continuous flow streams, for flow diversion, or as check dams. Silt fencing has been installed per the manufacturer's specifications and as detailed on Figure 4.2-1.

Silt fencing conditions are typically inspected and maintained following major rainfall events. Proper installation and frequent maintenance is required for effective sediment control.

#### **4.2.2.8 Temporary Sediment Traps and Sediment Basins**

A sediment trap/basin is a temporary structure that is used to detain runoff from small drainage areas (generally less than 2 hectares [ha]) to allow sediment to settle out. Sediment traps/basins have been and will be located in areas where access can be maintained for sediment removal and proper disposal. A sediment trap/basin can be created by excavating a basin, utilizing an existing depression, or constructing a dam on a slight slope downward from the work area. Sediment-laden runoff from the disturbed site is conveyed to the trap/basin via ditches, slope drains, or diversion dikes. The trap/basin is a temporary measure, and is to be maintained until the site is permanently protected against erosion by vegetation and/or structures.

Temporary sediment traps and sediment basins have been and will be constructed at the end of smaller collection ditches to detain sediment-laden runoff long enough to allow sediment to settle out. The size of the temporary sediment trap/basin is dependent on the ditch design flows. The exact locations and final geometry of the traps are field fitted to integrate with the terrain to minimize disturbance. The Site Services Manager or Technical Services Superintendent review and approve the sizing and location of these basins prior to construction with input from the Environmental Superintendent. The sediment traps/basins are inspected regularly. When the sediment trap/basin has accumulated sediment and/or debris, the traps are cleaned to restore design capacity.

Two sizes of sediment basins designated SB1 and SB2 have been developed for the site and used for different size drainage areas. The sizing and dimensions of the two sediment basins are summarized Table 4.2-1.

**Table 4.2-1: Temporary Sediment Basin Design Specifications**

	Sediment Basin size 1	Sediment Basin size 2
Drainage Area (hectares)	<1	1 - 2
Width (m)	10	12
Length (m)	20	25
Depth of Wet Storage (m)	1	1
Minimum Spillway Weir Length (m)	2	4

The width and length dimensions correspond to the top of the wet storage area, at the base of the outlet structure.

#### **4.2.2.9 Filter Bags and Geotubes**

Filter bags are generally constructed from a sturdy non-woven geotextile capable of filtering particles larger than 150 microns. Filter bags are typically installed at the discharge end of pumped diversions, via fabric flange fittings, to remove fine grained materials before discharging to the environment. These measures have not been utilized to date.

If and when used for fine grained materials, filter bags shall be installed on flat, stable, non-erodible foundations, or in well vegetated areas. The pumping rate shall be no greater than specified by the manufacturer. Discharge from filter bags will be routed to lined areas (i.e., rock aprons, riprap, etc.) to reduce water velocity and minimize erosion.

A smaller variety of filter bags, referred to as filter socks, can be installed on the discharge ends of gravity flow pipes, such as slope drains, to filter silt particles before discharging to the environment.

Filter bags shall be maintained in the following manner.

- Inspected daily for defects, rips, tears, sediment accumulation, and erosion of the surrounding area.
- When sediment fills one half of the volume of the filter bag, the filter bag shall be removed from service and replaced.

Spare bags shall be kept nearby to minimize time required to recommence pumping activities. Once the used bag is fully drained, the bag and its contents can be deposited in the reclamation material storage areas for use as cover materials during mine closure, or disposed of in the on-site landfill.

Geotubes can be used as part of a dewatering system to separate and contain solids in sediment-laden water. The system is composed of a geosynthetic tube, which is available in various sizes, and an injection port. The sediment-laden water is pumped or directed via gravity into the geotube until full. Clean water drains through the pores of the engineered textile, which allows the solids to consolidate inside the geotube. Once the apparatus is full of solids, it can be disposed of at a landfill or the solids can be removed and used on site.

#### **4.2.2.10 Flocculants**

The term flocculation is used to describe the aggregation of small particles clumping together and settling out of suspension. In sediment and erosion control applications, flocculation is achieved with the use of chemical or natural additives (e.g., corn starch, chitosan, guar gum). The flocculants accelerate the natural settling process in sedimentation ponds as the sediment-laden water flows through the pond, and therefore the required pond detention time is reduced. Additionally, flocculants can be added at specific points along collection ditches to initiate the settling process prior to arrival at the water management pond. This system may be beneficial in steep topographic areas where:

- The calculated surface area for the design particle size is not practical
- Where the clay component is high, as clay soil types have a lower settling velocity than other particles.

If site conditions necessitate the use of flocculants, SGC will use only products from the high molecular weight anionic polyacrylamides (or PAMs) group of flocculants, and that are non-toxic to fish to settle sediment in sediment control ponds or sediment basins. There is a wide range of anionic PAMs available for water clarification and erosion control. The methods used to identify the flocculants to be used for this project are described in the Flocculant Use Plan (Appendix A).

#### **4.2.2.11 Collection Ditches**

Strategically placed ditches and runoff collection structures can help direct water movement, which in turn limits erosion. A collection ditch intercepts sediment-laden water runoff from disturbed areas and diverts it to a stabilized area where it can be effectively managed. Collection ditches are used to collect runoff and convey it to the appropriate sediment control measures. General locations and conditions include the following.

- Below disturbed existing slopes to divert sediment-laden water to control facilities.
- At or near the perimeter of a construction area to prevent sediment-laden runoff from leaving the site.
- Below disturbed areas before stabilization to prevent erosion.

Ditch designs have been based on steady, uniform flow analysis.

Two large collection ditches (Ditch A and Ditch B, see section 6.1.2) have been built at the downslope perimeter of development activities including the WRSAs, open pit and crushers, while smaller collection and diversion ditches have been used to direct flow to the main catchment ditches. Cut and fill slopes leave long runs of exposed soils that are prone to erosion. A ditch placed above the cut slope will intercept water and direct it to less erosion prone areas. Typical collection and diversion ditches (two types) and pipe/ditch



combinations (for contact water emanating from the WRSAs and 90-day stockpile) are shown on Figure 4.2-3.

#### **4.2.2.12 Diversion Ditches**

Diversion ditches have been and will be constructed up-gradient of disturbed areas to intercept clean surface water runoff as practicable. A diversion ditch is a channel lined with vegetation, riprap, or other flexible, erosion resistant material. The main design considerations are the design flow and velocity of the water expected in the channel. All diversion ditches have been designed to carry the appropriate peak flow. All diversion ditches discharge through a stabilized outlet designed to handle the expected runoff velocities and flows from the ditch without scouring. The selection of a type of lining is based upon the design flow velocities.

#### **4.2.2.13 Roadside Berms and Ditches**

Major roads within the Project footprint also include a safety berm and roadside ditch to maintain a safe and dry driving surface. Safety berms are constructed with locally sourced fill material and the roadside ditch is either cut into the existing topography or excavated in the fill surface of the road. Whilst these features are not constructed to specific water management criteria (as in the case of the berm the configuration is derived based on safety requirements) these features act to support erosion and sediment control as they effectively channel surface runoff in local areas to low points of the road profile for exfiltration. Typical cross sections for haul and mine service roads are provided in Figure 4.2-4 and Figure 4.2-5.

#### **4.2.2.14 Culverts**

In general, while variations may occur due to site-specific conditions, culverts have been installed at a slope of 2% with an inflow along a smooth headwall. In some cases, a small energy dissipater or stilling basin is constructed upstream of each culvert to reduce sedimentation. The culverts in use consist of corrugated metal pipe or corrugated polyethylene tubing installed according to the manufacturer's specifications to accommodate the anticipated vehicle loading and to prevent crushing. Standard culvert details can be seen in Figure 4.2-1 and Figure 4.2-2.

#### **4.2.2.15 Exfiltration Areas**

An exfiltration area is used to treat sediment-laden water by detention in an area that is not lined, and which allows the water to filter through the natural ground surface leaving the sediment behind. This process provides complete capture of the sediment as it filters the water only and does not allow for any additional outflows such as riser pipes and/or spillways, which are commonly used in sediment ponds/basins.

Where feasible, exfiltration areas have been designed to detain the 10-year 24-hour storm event. The hydraulic conductivity of surficial material on site ranges from  $10^{-3}$  to  $10^{-7}$  m/s. A value of  $10^{-7}$  m/s is used for the design of the exfiltration areas.

Section 4 Design Basis and Criteria

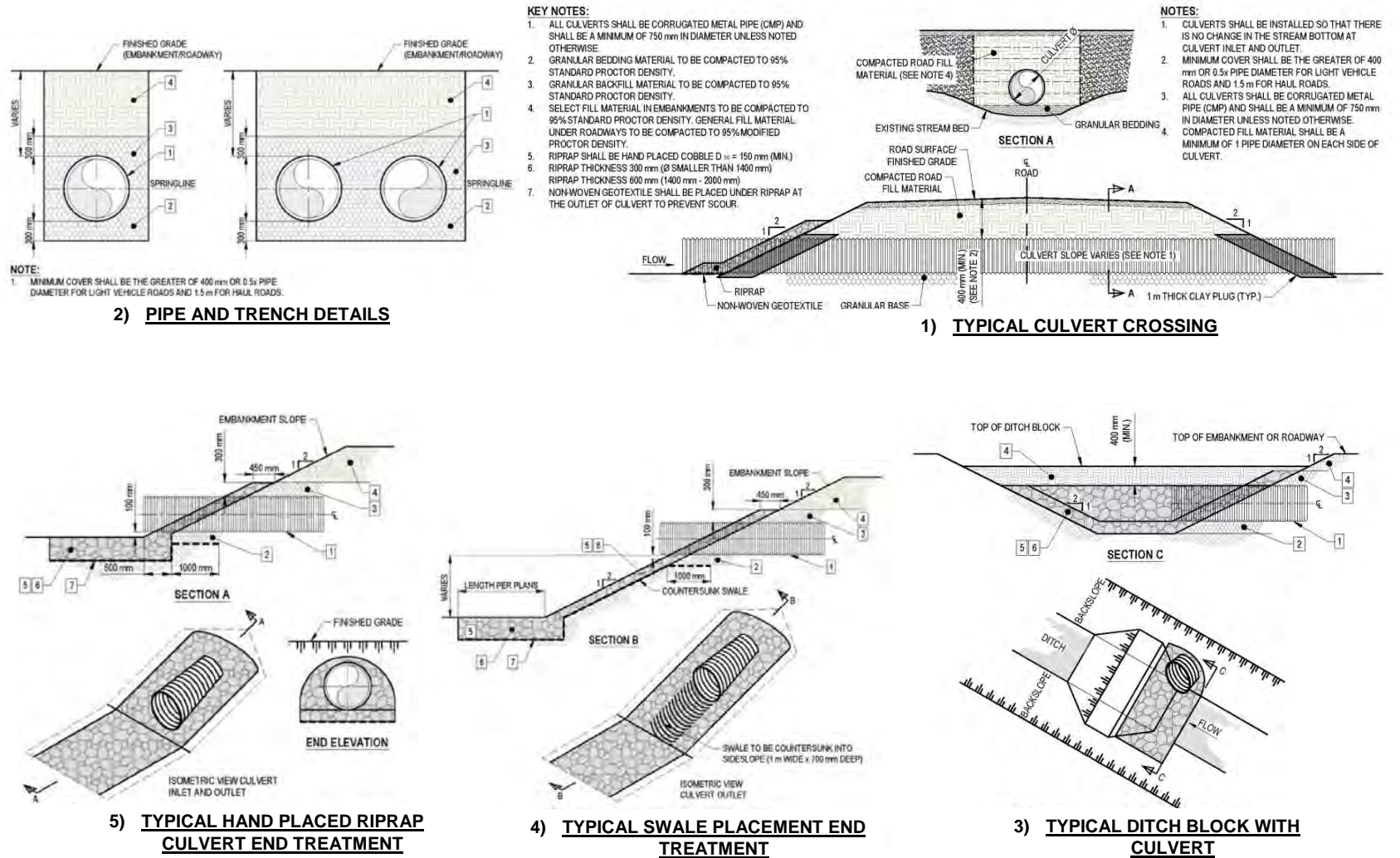

Figure 4.2-1: Culvert Sections and Details

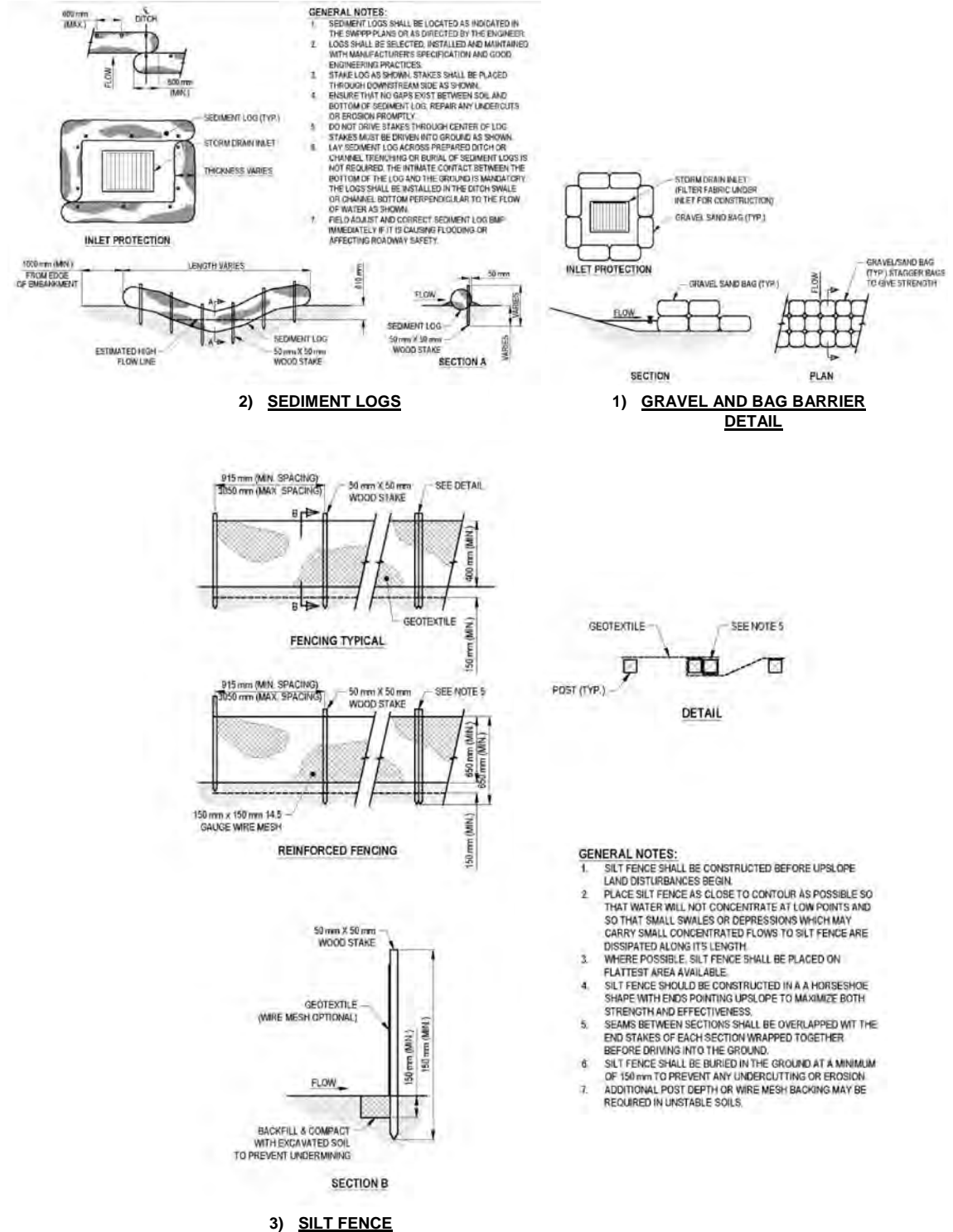

Figure 4.2-2: Erosion Control BMP - Sections and Details - Sheet 1 of 2

Section 4 Design Basis and Criteria

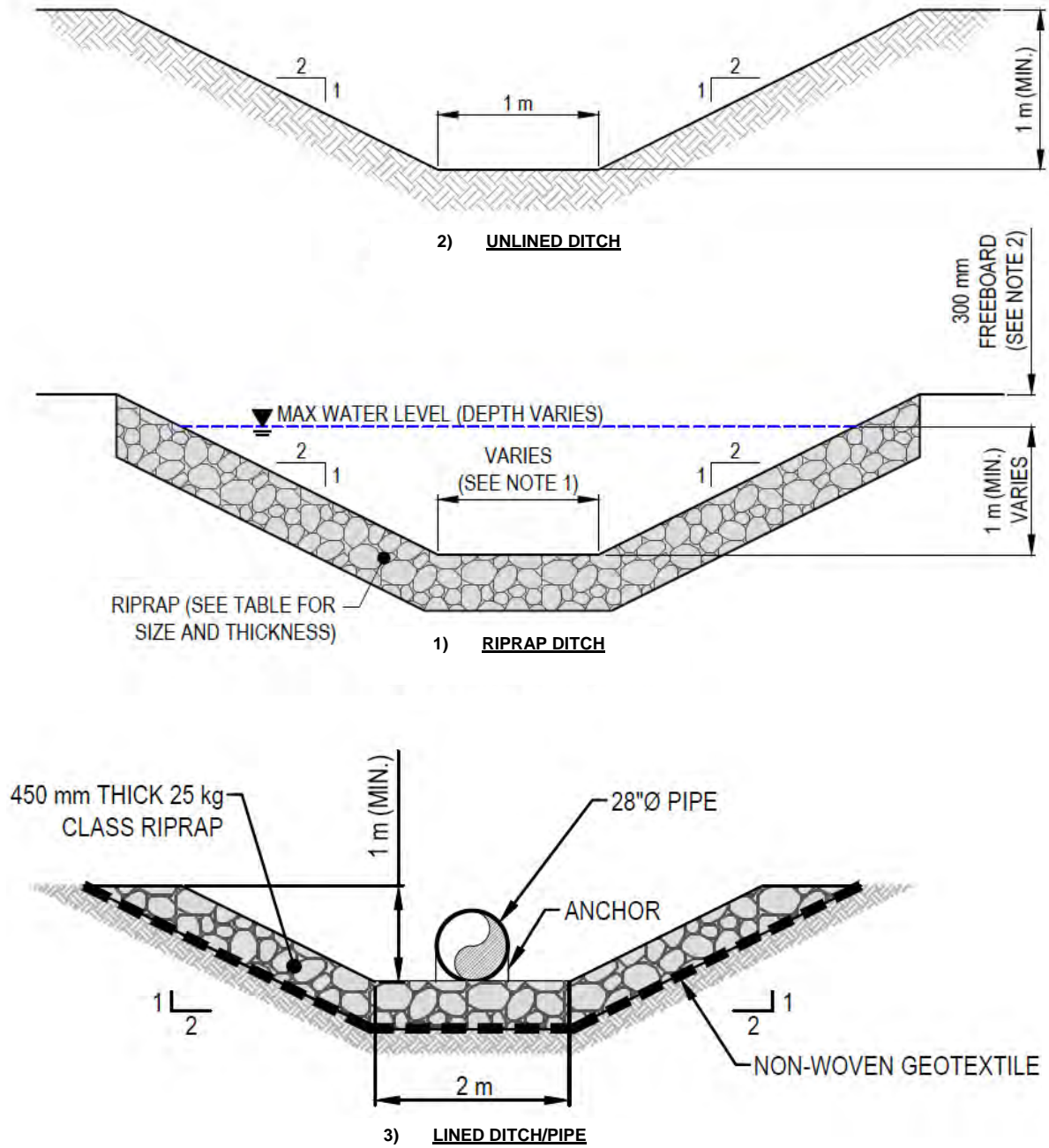

Figure 4.2-3: Erosion Control BMP - Sections and Details - Sheet 2 of 2

Section 4 Design Basis and Criteria

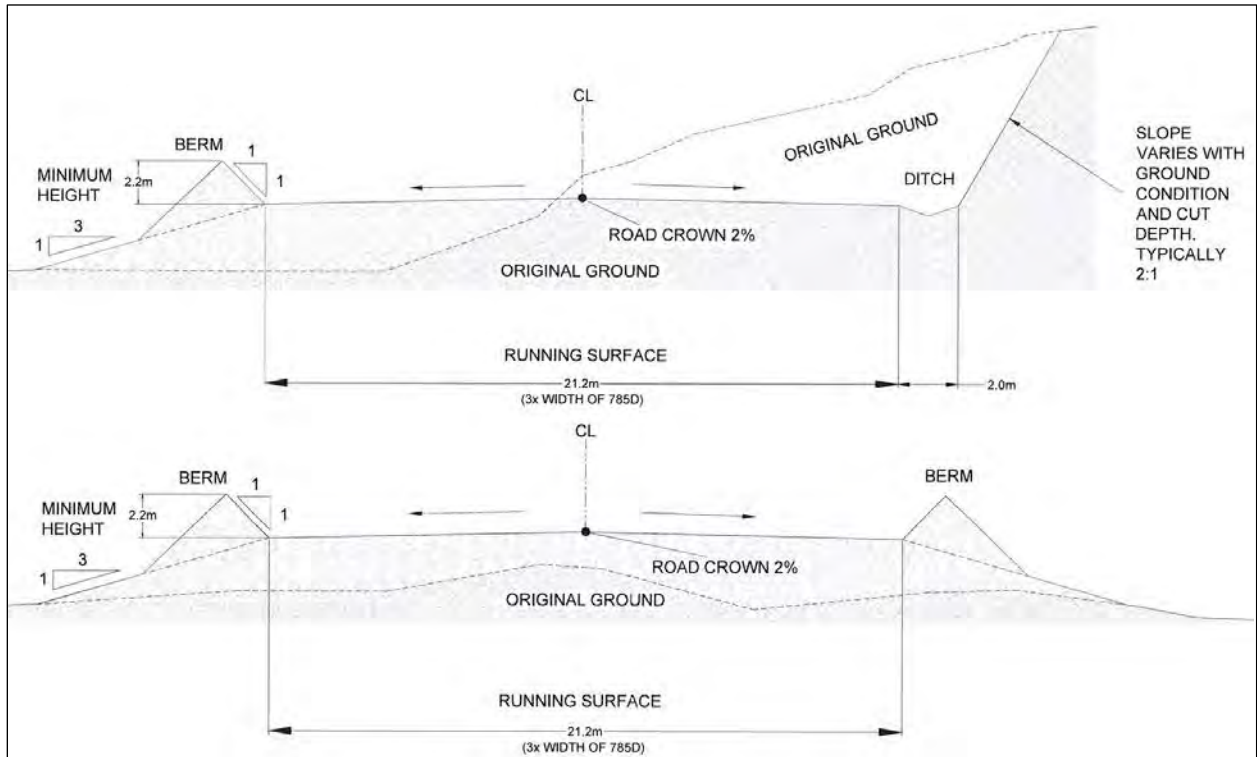

Figure 4.2-4: Haul Road Typical Cross Sections

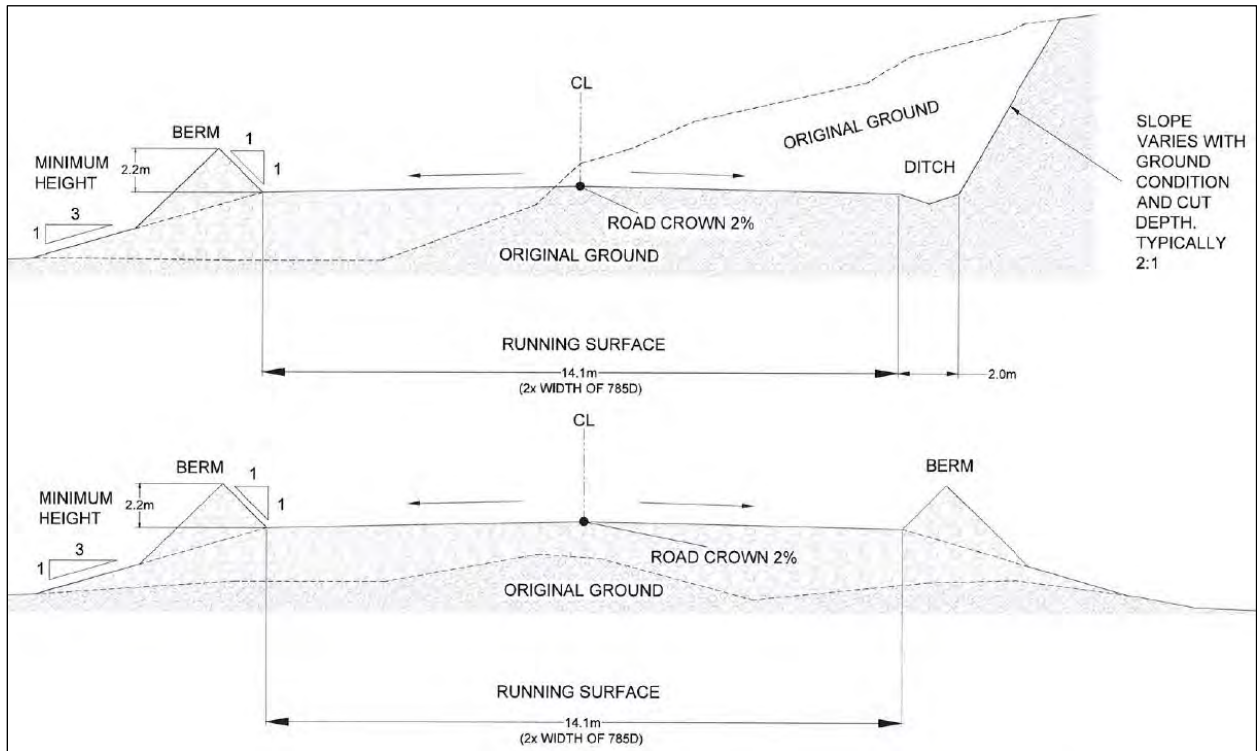

Figure 4.2-5: Mine Service Road Typical Cross Sections

### **4.3 DISCHARGE PROTOCOLS**

When sample results are below the adaptive management threshold of a specific effluent quality criteria, monitoring frequency (of both flow rate and water quality) will continue at the specified rates provided in Tables 3.5-1 (Operations and Active Closure) and 3.7-1 (Late Closure and Post Closure) of the EMSAMP. When sample results exceed the adaptive management thresholds listed in Table 3.8-2 (Operations, Closure and Post Closure) of the EMSAMP, the sampling frequency will increase accordingly (to the next higher order) to better characterize any trends. For example, monitoring frequencies will be increased from monthly to weekly, or weekly to daily, or daily to four times a day as specified by specific adaptive management actions for each threshold, until the source of the trends have been identified and mitigated.

## 5 WATER BALANCE, STORM WATER & GROUNDWATER

Several detailed water-related models were developed and/or used specifically for the Project to simulate the effect of land use changes due to the project within the Project study area (Haggart Creek, Dublin Gulch and Eagle Creek drainage basins). These include the:

- Site Surface Water Balance Model;
- Heap Leach Facility Water Balance Model;
- Water Quality Model;
- Storm Water Model; and
- Numerical Groundwater Model.

These models are structured to provide dynamic spatial and temporal modeling frameworks to represent various physical conditions and simulate changes to the hydrologic regime over the course of the life of the Project. The modeling results provide input to the development and implementation of water management planning for all facets of the project. This section briefly describes each model that informed the development of site water management infrastructure design.

As the design and construction of major water management infrastructure has either been completed or will be developed further during the operational life of the Project, specific model results are not relevant here. Reviewers of this plan should consult the Environmental, Permitting, or Technical Services Departments with respect to the inputs, modelled scenarios, and outputs of each model as necessary.

### 5.1 SURFACE WATER BALANCE MODEL

A surface water balance model (WBM) was created in support of the Eagle Gold Project and was used to simulate the availability and usage of water for operating the Eagle Gold Mine, including the HLF. The WBM simulates the supply and demand for water on a month-by-month basis, from the initiation of mine operations through mine closure and post-closure. The WBM was created using GoldSim®, a dynamic probabilistic simulation model used extensively for mine site water management applications. GoldSim® permits inputs to be entered as probability distributions (rather than discrete values), performs Monte Carlo simulations, tracks outputs from those simulations, and provides a graphic interface to facilitate the review and identification of interactions between components.

The WBM is updated on an annual basis to reflect updates to the climate and hydrology databases.

### 5.2 HEAP LEACH WATER BALANCE MODEL

Heap leach water balance models have been developed (and will be continually updated) for the Project with the objectives of evaluating HLF pad performance in terms of predicting and tracking: 1) makeup water demands, 2) tracking water volumes in the HLF system, and 3) the potential for maintaining an adequate level of emergency pond storage volume. Three (3) different types of water balance models have been used to date: a weekly timestep deterministic model (using a chain of single valued input parameters to produce a series of single valued results),

a weekly timestep stochastic model (probability based), and an operational model focused more on daily inputs and outputs.

### **5.2.1 Deterministic Model**

For the deterministic model, a 68-year site synthetic meteoric record (Lorax 2017a) is used for the modeling of the facility operational life, which includes active ore stacking, a period of gold extraction after the cessation of ore stacking, and an additional period that represents the initiation of draindown and closure.

A three (3) year dry period and a three (3) year wet period, taken from the 68-year synthetic record was included within the mine life. Inclusion of these wet and dry periods in the deterministic record assure that the potential impact of historically observed variations in precipitation are represented by the model and included in the expected operating range.

Air temperature was also included in the site synthetic meteoric record, as it is a major factor in the climate of the site influencing the fluctuations and phases of meteoric water. The water balance model controls the accumulation of SWE in the snowpack as a function of precipitation and temperature using a monthly series of snowpack factors. Similarly, the evaporation data provided in the Lorax (2017a) site synthetic record was included; for the coldest months with mean monthly temperatures below freezing, the potential evaporative loss was replaced with a sublimation loss assumed to be 20% of the monthly precipitation (Lorax 2017a).

The deterministic model uses the synthetic precipitation record, number of days of precipitation, temperature, and the synthetic evaporation time history for the same time period to track system storage and makeup water demand on a monthly basis, compute a single value for all variables and provide results for each month in the record. System storage and makeup water demand is also analyzed.

### **5.2.2 Stochastic Model**

For use in stochastic modeling, descriptive statistics were developed for the compiled monthly values from the 68-year synthetic meteoric record. Rather than singular climate inputs (i.e., the synthetic record), the stochastic model substitutes probability distributions for the discrete monthly rainfall, temperature, and evaporation values and samples the distributions based on the observed statistical parameters (monthly mean and standard deviation). Then the model compiles new probability distributions for the results of interest.

Stochastic modeling results can be used to inform suitable volumes of water stored that can be stored within the pond system and the ability to maintain an adequate level of emergency storage volume. The available emergency storage volume is defined as the total pond capacity minus the volume of water in storage within the pond system at any given point in time.

### **5.2.3 Operational Model**

The HLF operational model is built on a GoldSim® platform with similar principals to the other two HLF water balance models in terms of tracking meteoric variability, but is computed on a 6-hour basis to track in more detail water inputs, stacking sequence, lift volumes, ore properties (e.g., moisture, density, gold grade, etc), contained gold, solution flow rates and in-heap pond water levels. This model will be used to output data on a weekly or monthly basis, to feed into the site-wide water balance model and also conduct stochastic analyses (as required by QZ14-041).



### 5.2.4 Heap Draindown

Once all gold production has ceased and cyanide neutralization and rinsing of the HLF is finished, the post closure heap will be allowed to dewater and drain. The draindown process is an unsaturated flow process that is controlled by the soil water retention characteristics of the ore. The rate of flow during draindown is a function of the unsaturated hydraulic conductivity which is in turn a function of the moisture content of the ore. As the ore drains, the moisture content decreases and the effective unsaturated hydraulic conductivity declines as well leading to an exponentially declining flow rate curve.

It is not practical nor advantageous to simply turn off the pumps and allow the heap to just drain as a very large volume of water would report quickly to the ponds, filling and overflowing them. Therefore, the HLF model assume that pumping of process solution will continue at a declining rate until such time as the water content in the active leach column approaches the water content in the unirrigated ore, or the potential draindown volume remaining would not fill the ponds but would be captured in the pond system and still provide sufficient capacity to capture and store the design events (i.e., 1% probability (100 yr) 24 hr storm and a short-term drain-down). At that point the pumps could be turned off while allowing the heap to continue to drain until it reaches a meta-stable equilibrium with the level of meteoric water that continues to enter the pad year after year.

## 5.3 WATER QUALITY MODEL

The Eagle Gold Project water quality model (WQM) is a mass-conserving mixing model that predicts water quality for 38 parameters at key monitoring and compliance points in the receiving waters affected by mine activity. The model was designed on the GoldSim® platform and utilizes a GoldSim® water balance model (WBM). The WBM is updated annually to reflect additional data collected. Both the WBM and the WQM use a monthly time-step. Model inputs include seepage contact water source terms, Mine Water Treatment Plant (MWTP) and Passive Treatment Systems (PTS) effluent discharge requirements and background water quality for non-contact flows.

The model assumes that contact water comes from the following sources:

- Waste rock storage facilities in Eagle Pup and Platinum Gulch;
- Pit wall runoff and pit-wall depressurization wells that report to pit;
- Heap leach facility (during post-operations and drain-down only); and
- Runoff-seepage from developed and undeveloped portions of the project footprint

The effluent quality standards for the Project listed for each component are utilized in the model. Background flows and water quality from runoff (e.g., non-contact water) and background receiving environment water chemistry are fully characterized and included in the model and, as the Project advances, actual contract water quality information will be used as a model input during the yearly update to the model.

## 5.4 STORM WATER MODEL

A series of hydrological models using HEC-HMS and PCSWMM software were run to estimate the Inflow design flood for Ditch A, Ditch B, Ditch C, Lower Dublin South Pond and various culverts throughout the project site, and to size them based on the corresponding design events. The as-built record drawing package is included as Appendix B. The issued for construction design specifications and drawing package which includes water management infrastructure that is yet to be required is provided as Appendix C.

The more conservative adjusted rainfall frequency atlas values for extreme precipitation were used as input to the rainfall runoff hydrologic models. The general basin model developed using the HEC-HMS software is shown in Figure 5.4-1. The catchment physical characteristics for the model are summarized in Table 5.4-1. The results of the rainfall runoff analysis are summarized in Table 5.4-2.

**Table 5.4-1: Catchment Areas Used in the Model**

Catchment ID	Area (km <sup>2</sup> )	Curve Number (CN)	Lag Time (min)
Dublin Gulch	3.27	60	42
Olive Gulch	2.80	60	38
Stewart	1.66	60	27
North Dublin Gulch	0.63	60	14
Lower Dublin Gulch	0.24	60	6.8
Eagle Pup	1.47	82	41
Suttles Gulch	1.00	82	32
Ditch A	1.57	82	48
Lower Eagle Creek	0.19	82	10

Sources: Tetra Tech 2014, StrataGold 2015 and BGC 2017

**Table 5.4-2: Flood Volume and Peak Runoff Values Estimated from the Rainfall Runoff Analysis**

Catchment ID	Flood Volumes (1000 m <sup>3</sup> )				Peak Flow (m <sup>3</sup> /s)			
	10 Year	100 Year	200 Year	1000 Year	10 Year	100 Year	200 Year	1000 Year
Dublin Gulch	3.73	21.28	28.6	48.9	3.73	1.12	1.65	3.25
Olive Gulch	3.23	18.36	28.6	42.13	3.23	1.01	1.65	2.98
Stewart	1.95	11.00	28.46	25.19	1.95	0.65	1.64	2.00
North Dublin Gulch	0.77	4.27	24.66	9.75	0.77	0.31	1.49	1.01
Lower Dublin Gulch	0.30	1.66	53.12	3.78	0.30	0.14	3.12	0.48
Eagle Pup	22.09	45.33	52.78	71.13	22.09	5.25	3.09	8.39
Suttles Gulch	15.09	30.94	14.76	48.54	15.09	3.90	0.99	6.27
Ditch A	23.82	48.85	67.54	76.64	23.82	6.16	3.95	9.91
Lower Eagle Creek	2.83	5.8	67.49	9.09	2.83	1.13	3.94	1.79
Total (Eagle Pup, Suttles Gulch and Ditch A)	61.0	125.1	135.1	196.3	61.0	15.3	8.0	24.6

Using the model, a total runoff volume of 61,000 m<sup>3</sup> was estimated from the Eagle Pup, Suttles Gulch and Ditch A catchments during the 10 year event. This volume will be conveyed to and stored in the LDSP (Figure 5.4-2).

The pond includes a rock-fill forebay to slow down the flow and promote additional settlement for coarser material just before entering the main pond. During the 10-year 24-hour event, the maximum water level will be less than 811.5 m leaving a freeboard of 2.0 m.

The pond was designed to have a detention time of a minimum of 24 hours. Water outflow will be discharged if water is not needed for other purposes (i.e., dust, make-up water) and if effluent quality criteria are met.

The pond and outflow levels will be controlled through a riser and a low level outlet, which consists of a perforated stand-pipe with a control gate. A submersible pump will be installed in the riser; pump outflow will be sent to a pipe junction that can direct water to the ADR for make-up water; if make-up water is not needed, water flow will be conveyed to the MWTP for treatment prior to discharge.

The LDSP also includes an underdrain system that was installed to mitigate hydrostatic pressures on the pond from groundwater that convey non-contact groundwater to lower Eagle Creek.

In accordance with the design specifications and the Canadian Dam Safety Guidelines (CDA 2007), the LDSP includes a spillway capable of safely routing the 1,000-year flood during the Inflow Design Flood.

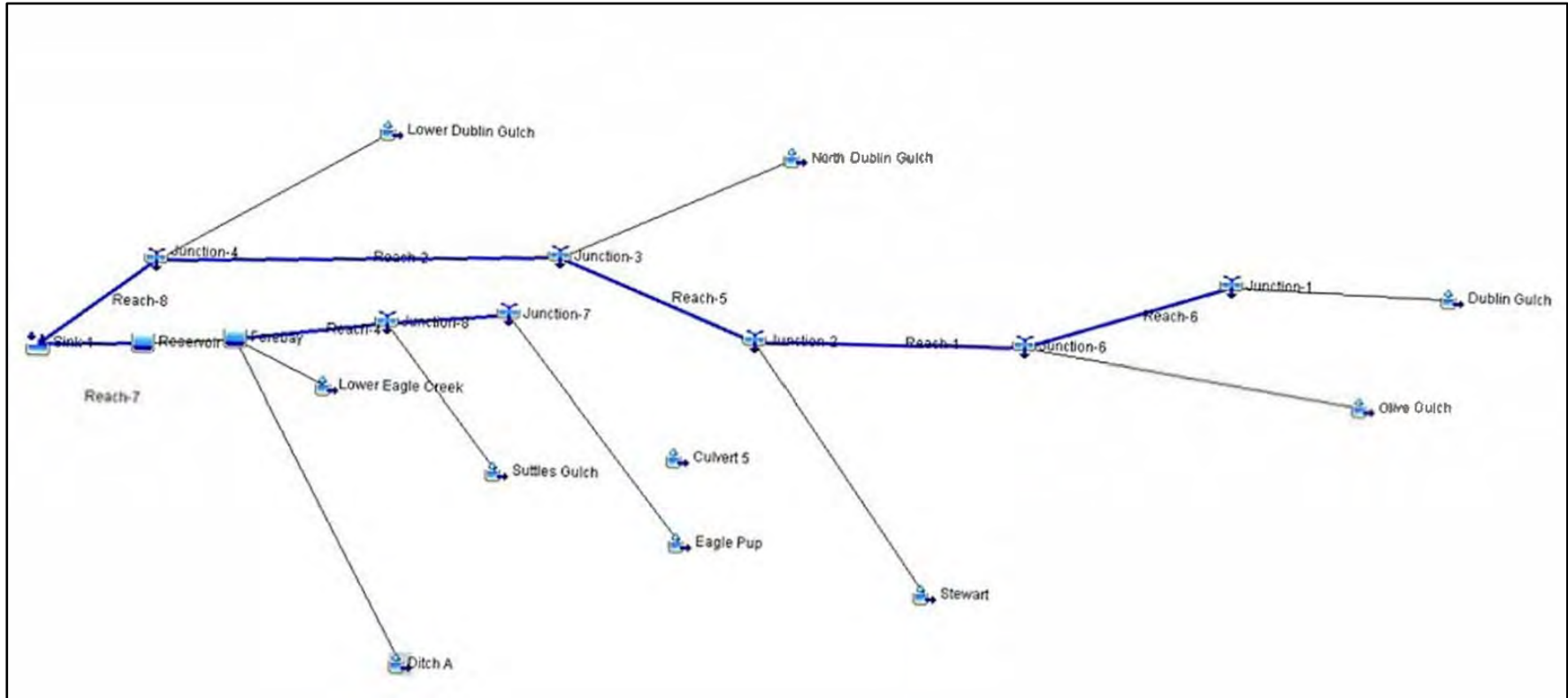
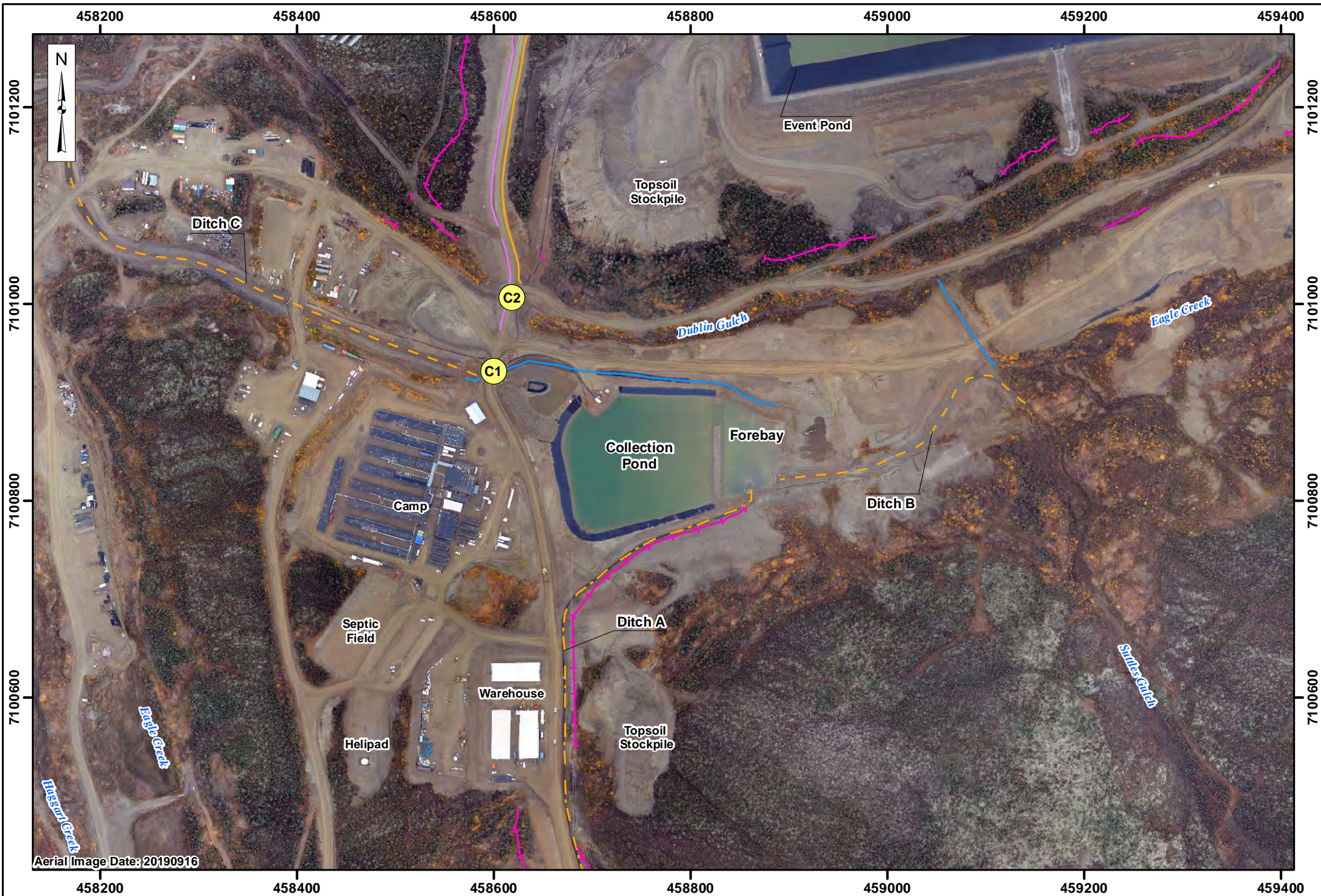

Figure 5.4-1: Eagle Gold Basin Model



Legend:

	Reserved Area		Collection Ditch & Pipe		Road Berm
	Culvert		Collection Ditch		Silt Fence
	Road Ditch		Diversion Ditch		

StrataGold Corporation

0 37.5 75 150  
Metres

Projection: NAD 83 UTM Zone 8N	Drawn By: HC
Date: 2020/01/10	Figure: 5.4-2

**EAGLE GOLD PROJECT  
YUKON TERRITORY**

**Lower Dublin South Pond  
Current Status**

## **5.5 GROUNDWATER MODEL**

With respect to site water management, a three dimensional (3-D) finite difference numerical groundwater flow model for the site was developed by BGC (2019) to:

- quantify groundwater inflows to the proposed open pits,
- evaluate the range or potential hydrogeologic impacts of the mine on surface water flows in the vicinity of mining operations.
- predict changes to the project area groundwater flow regime due to mining activities, and
- evaluate post-closure groundwater flow conditions.

### **5.5.1 Conceptual Hydrogeologic Model**

Measured groundwater elevations suggest that the water table is a subdued replica of topography, with depths to groundwater typically being greater in the uplands relative to the valley bottom. Groundwater enters the flow system from infiltration of precipitation and snowmelt, as well as by surface water infiltration in creeks and gullies. Groundwater discharge occurs primarily to creeks. Groundwater elevations are observed to slowly decline through the winter and spring (i.e. November to April), rise during spring melt and are highest during the summer (i.e. June to September). The seasonal variation in groundwater levels is consistent with the seasonal precipitation and temperature trends.

Surficial materials at the site comprise a thin layer of overburden (typically less than 10 m thick) that is generally composed of a thin veneer of colluvium in the uplands; while alluvium and reworked placer tailings dominate in the valley bottoms. Discontinuous, relatively warm (typically 0° to -1° Celsius) permafrost is present primarily along northeast to northwest-facing slopes with sporadic distribution in the general area. Because of its discontinuous nature it is assumed to have limited regional control on the groundwater flow system.

The bedrock of the project area can be broadly divided into the Hyland Group metasediments and intrusive rocks of the Dublin Gulch Stock. Results from hydrogeologic tests conducted in the bedrock to date show that the hydraulic conductivity of the intrusive and metasediment units is generally similar and associated with fractures, although considerable variation in results is apparent for each unit at any given depth (i.e., 2 to 4 orders of magnitude). Measured hydraulic conductivity ranges from  $3 \times 10^{-5}$  to  $4 \times 10^{-3}$  m/s in placer and fluvial overburden materials, and  $4 \times 10^{-7}$  to  $3 \times 10^{-5}$  m/s for colluvium. Within bedrock, hydraulic conductivity estimates from site data range from  $2 \times 10^{-6}$  to  $2 \times 10^{-8}$  m/s, and exhibit a decreasing trend with depth. Specific storage (Ss) estimated from pumping tests ranged from  $8 \times 10^{-6}$  m<sup>-1</sup> to  $1 \times 10^{-5}$  m<sup>-1</sup> for bedrock and from approximately  $3 \times 10^{-5}$  m<sup>-1</sup> to  $6 \times 10^{-3}$  m<sup>-1</sup> for overburden.

### **5.5.2 Groundwater Model Development**

Groundwater Vistas (Version 7.23; ESI, 2017), a graphical user interface, was used to develop the MODFLOW-SURFACT (Version 3.0) groundwater flow model for the site. The groundwater flow model domain extends beyond the project footprint and local topographic divides to the north and south to major streams and to the east and west to the major topographic divides. The model consists of an approximate area of 82.5 km<sup>2</sup>, 65.3 km<sup>2</sup> of which is within the active model domain.

Continuous, semi-continuous and single groundwater elevation data were used with average annual and mean estimated monthly flows from gauging stations on Stewart Gulch, Dublin Gulch, Eagle Creek and Haggart Creek were used to help calibrate the groundwater flow model to both static and transient conditions. In addition, the model was then calibrated using data from pumping tests conducted in bedrock and alluvial aquifer wells. Comparison of simulated versus observed drawdowns suggested that the calibrated hydraulic conductivity values were reasonable for the project scale of the modeling.

### **5.5.3 Model Results**

#### **5.5.3.1 Open Pit Advance and Mine Dewatering**

Due to the relatively low hydraulic conductivity of the rock mass in the open pit area, pumping wells are not likely to provide a practical or economically efficient means of depressurizing the open pit slopes. Lowering of the groundwater table due to pit excavation and dewatering/depressurization is expected. Active depressurization methods were not examined by BGC in this version of the model (BGC 2019)

#### **5.5.3.2 Groundwater Supply Extraction**

Model results indicate that one to two groundwater supply wells installed in the bedrock of the lower Dublin Gulch valley will be able to sustain the estimated groundwater supply demands (i.e., for process make-up water when the LDSP water supply is limited) as estimated by the site-wide surface water balance model.

#### **5.5.3.3 Flow in Haggart Creek**

As a result of the open pit advance, groundwater supply demands, and reduced recharge from the HLF and WRSA footprints, the model predicted lower hydraulic heads (i.e., drawdown) in the project footprint. During operations this translated to a slight decrease in stream baseflow and a slight increase in stream leakage to the aquifer which resulted in stream flow reductions at W5 of generally less than 1% from May through October to 2% to 5% from December to April. Long term reductions to stream flow at W5 are estimated at approximately 0.5%.

## 6 WATER MANAGEMENT IMPLEMENTATION

The water management objective is to safely convey and/or detain the respective design storm event at each facility, while keeping clean water clean (i.e., maintaining water quality at background levels) and by meeting water quality standards in the receiving environment.

The primary means of achieving the water management objective is by selecting appropriate design inputs (as discussed above), operating an integrated system of sediment-laden and contact water management infrastructure, ongoing erosion source control (i.e., minimizing total suspended solid levels in runoff from disturbed areas) and the diversion of non-contact water away from disturbed areas to reduce the total volume of water needing to be managed.

This section provides an overview of how the key water management facilities integrate with one another and also describes the approach to the management of sediment-laden water.

Water will be controlled in a manner that minimizes erosion and minimizes the chance of release of contact waters to receiving waters (e.g., Dublin Gulch, Haggart Creek, and Eagle Creek).

A critical consideration for all decisions for planned release of water from the Project site is the effluent quality criteria. Table 6.1-1 provides the currently authorized discharge limits for the Project.

**Table 6.1-1: Effluent Quality Criteria**

Parameter <sup>1</sup>	Maximum Concentration in a Grab Sample
pH	6.5 – 8
Total Suspended Solids (TSS)	15.00 mg/L
Sulphate	1850 mg/L
Chloride	250 mg/L
Nitrate-N	19.5 mg/L
Nitrite-N	0.12 mg/L
Ammonia-N	7.5 mg/L
Total Cyanide	1.0 mg/L
WAD Cyanide	0.03 mg/L
Aluminum (Dissolved)	0.4 mg/L
Antimony	0.13 mg/L
Arsenic	0.053 mg/L
Cadmium	0.00125 mg/L
Copper	0.026 mg/L
Cobalt	0.026 mg/L
Iron	6.4 mg/L
Lead	0.05 mg/L
Mercury	0.00008 mg/L
Manganese	7.7 mg/L
Molybdenum	0.45 mg/L
Nickel	0.50 mg/L
Selenium	0.025 mg/L



Parameter <sup>1</sup>	Maximum Concentration in a Grab Sample
Silver	0.01 mg/L
Uranium	0.09 mg/L
Zinc	0.23 mg/L

1 – All concentrations are total values except where noted

As discussed in Section 2.3, no decision for a release of water from any Project facility can be undertaken without following the roles and responsibilities guide. If there is any circumstance in which a release of water from key water management facilities is likely and is considered by an observer to not have been authorized in accordance with Section 2.3, then the VP Operations and General Manager must be contacted immediately.

## 6.1 KEY WATER MANAGEMENT FACILITIES

The integrated water management facilities for the Project discussed in this section are shown in Figure 6.1-1.

### 6.1.1 Lower Dublin South Sediment Control Pond

The LDSP is managed as a retention pond that collects water from disturbed areas in the southern section of the Project including runoff and mine water routed from the Eagle Pup WRSA, Platinum Gulch WRSA, the crusher areas in Suttles Gulch, and the open pit. Ditch/pipe configurations (referred to as Ditch A and Ditch B) route these contact waters to the LDSP.

The pond has been designed and built to store the 10-year, 24hr storm event for all surface runoff from the catchments that report to Ditch A and Ditch B while at the same time providing a retention time of at least 24 hours for any sediment particles sized 0.005 mm (and larger) to settle out. The spillway of the pond is designed to pass the 1000-year, 24-hour storm while still maintaining at least 0.5 m of freeboard.

Water contained within the LDSP is intended to be dispatched to the HLF as makeup water (see Section 7), routed to treatment, or discharged provided that the water meets the discharge requirements. Later in mine life and depending on process water demand, excess water from the LDSP above the assumed process make-up requirements, will be sent to Haggart Creek via the mine water treatment system (as necessary).

If water within the LDSP is not required for other purposes, and in accordance with the approval process considered in Section 3, water within the LDSP will be released via the controlled outlet pipe from the pond into Ditch C, which flows into Haggart Creek about 200 m downstream from the mouth of Dublin Gulch (Figure 6.1-1) and upstream of the water quality monitoring station W4.

Due to the correlation between TSS and As at the Project site (the primary parameters that may exceed discharge criteria), if it is observed that the TSS in the pond discharge could exceed the maximum permitted or regulated discharge quality, then settling aids (e.g., flocculants) may be added upstream of the pond outlet. The procedures for addressing elevated TSS are described in the Flocculant Use Plan (Appendix A)

### 6.1.2 Culverts, Ditches and Pipes

#### 6.1.2.1 Culverts

Figure 6.1-1 depicts eight watercourse crossings along site roads. Culverts are sized to convey the 1 in 10-year 24-hour storm event for temporary crossings, the 1 in 100-year 24-hour storm event for crossings with a

catchment area larger than 1 ha, and the 1 in 200-year 24-hour storm event for stream crossings (i.e., Dublin Gulch and Eagle Creek).

The culverts consist of corrugated metal pipe installed according to the manufacturer's specifications and are sized as shown in Table 6.1-2. Culverts are embedded in gravel and/or constructed with baffles for those crossings where fish passage occur.

The hydrologic model described in Section 5.4 was used to predict the design flows for each crossing. The culverts were sized using standard culvert nomographs and the PCSWMM modelling software.

**Table 6.1-2: Culvert Specifications**

Culvert ID	Catchment Area (Ha)	Design Criteria	Total Rainfall Depth (mm)	Rainfall Distribution	Peak Intensity (mm/h)	Design Flow (m <sup>3</sup> /s)	Length (m)	Slope	Diameter (mm)	# of pipes
1	422.2	IDF from Emergency Spillway	94.0	Type 2	104.3	24.0	28	2.4%	2200	2
2	860.9	1 in 200-year, 24-hour	78.2	Type 2	86.8	4.3	49	5.7%	1200	2
3	846.7	1 in 10-year, 24-hour	49.1	Type 2	54.5	0.3	30	8.7%	750	1
4	836	1 in 200-year, 24-hour	78.2	Type 2	86.8	4.2	58	2.7%	1200	2
5	11.2	1 in 200-year, 24-hour	78.2	Type 2	86.8	1.2	44	7.1%	800	1
6	166.2	1 in 200-year, 24-hour	78.2	Type 2	86.8	1.0	40	7.1%	750	1
7	653.2	1 in 200-year, 24-hour	78.2	Type 2	86.8	3.1	78	7.1%	900	2
8	133.8	1 in 100-year, 2-hour	71.6	Type 2	79.4	5.3	56	3.0%	1200	2
9	na	IDF from Emergency Spillway	94.0	Type 2	104.3	24.0	28	2.4%	2200	2

### 6.1.2.2 Ditches

There are three main ditches related to sediment-laden and contact water for the Project, shown on Figure 6.1-1 and described below:

**Ditch A** is located downslope from the open pit, the Platinum Gulch WRSA, the 90 day stockpile and the open pit access road. Ditch A runs north from the drainage basin of the Platinum Gulch WRSA across the site and into the Lower Dublin South Pond.

When the entire stretch of **Ditch B** is completed it will follow the natural Eagle Creek watercourse, and receive runoff from the Eagle Pup WRSA, and Suttles Gulch which contains the crusher installations and part of the Eagle Pit. Ditch B will flow west across site from the northern end of the Eagle Pup WRSA to the LDSP. Currently only the reach from Suttles Gulch to the LDSP is completed.

**Ditch C** is downslope of the LDSP, and conveys the outflow from the pond to Haggart Creek. Ditch C flows west to a discharge location upstream of W4.

The hydrologic model described in Section 5.4 was used to predict the design flows for each ditch. The design criteria and design flows are presented in Table 6.1-3.

**Table 6.1-3: Water Management Ditch Design Specifications**

Ditch	Design Criteria	Rainfall Depth (mm)	Rainfall Distribution	Peak Intensity (mm/h)	Catchment Area (ha)	Design Flow (m <sup>3</sup> /s)
Ditch A - Upstream of Culvert 8	1 in 100-yr, 24-hour	71.6	Type 2	79.48	133.8	5.3
Ditch A - Downstream of Culvert 8	1 in 100-yr, 24-hour	71.6	Type 2	79.48	157.4	6.2
Ditch B	1 in 100-yr, 24-hour	71.6	Type 2	79.48	246.3	8.9
Ditch C	IDF from Emergency Spillway	-	-	-	422.2	24

A PCSWMM hydraulic model was implemented as part of the design process to predict velocity and water depth along the ditches.

The design of the ditches was based on the gradient and volume of flow anticipated.

- Ditch Types 1 and 2 are used for small watersheds limited to channel slopes of 1% to 2%).
- For larger watersheds with channel slopes of 2% to 15%, a Type 3 ditch is used that includes geotextile liner and a riprap lining with a D50 of 150 mm minimum, and a riprap thickness of at least two times the D50 of the riprap in the channel. The riprap class for each reach of ditch was design as per the Ministry of Transportation BC Supplement to TAC Geometric Design Guide, 2007.

Table 6.1-4 presents the ditch characteristics and specifications for riprap protections. The stationing increases in the downstream direction.

**Table 6.1-4: Collection Ditch Specifications**

DITCH A Specifications											
ID	From Station (m)	To Station (m)	Length (m)	Slope (%)	Velocity (m/s)	Max. Depth (m)	Bottom Width (m)	Side Slopes (XH:1V)	Class of Riprap (kg)	D50 (mm)	
1	0	355	355	2 - 5	1.3 - 2.0	1.4	1	2	10	195	
2	355	519	164	1 - 2	1.0 - 2.8	1.6	1	2	No riprap required		
3	519	575	56	Culvert 8							
4	575	845	270	2 - 5	1.6 - 2.2	1.2	1	2	10	195	
5	845	1020	175	1 - 2	2.4 - 2.9	1	1	2	No riprap required		
6	1020	1195	175	2 - 5	2.0 - 3.0	1	1	2	25	260	
7	1195	1155	135	6 - 15	3.7 - 4.6	0.8	1	2	25	260	
8	1155	1240	45	6 - 15	6.9	0.6	1	2	500	715	
9	1240	1200	45	> 15	10.4	0.4	1	2	Culvert Lined		
DITCH B Specifications											

ID	From Station (m)	To Station (m)	Length (m)	Slope (%)	Velocity (m/s)	Max. Depth (m)	Bottom Width (m)	Side Slopes (XH:1V)	Class of Riprap (kg)	D50 (mm)
1	0	45	45	Culvert 5						
2	45	50	5	Gabion steps – 3 meter drop						
3	50	560	510	6 - 15	3.4 - 6.2	1.1	1	2	250	565
4	560	1026	466	2 - 5	2.0 - 2.9	1.3	1	2	25	260
5	1026	1120	94	6 - 15	5.0 - 5.4	1	1	2	250	565
DITCH C Specifications										
ID	From Station (m)	To Station (m)	Length (m)	Slope (%)	Velocity (m/s)	Max. Depth (m)	Bottom Width (m)	Side Slopes (XH:1V)	Class of Riprap (kg)	D50 (mm)
1	0	20	20	6 - 15	3.7	1.9	2	2	50	330
2	20	57	37	2 - 5	1.3 - 2.0	2.9	2	2	10	195
3	57	90	33	Culvert 1						
4	90	287	197	2 - 5	2.3 - 3.9	1.8	2	2	25	260
5	287	407	120	6 - 15	5.9 - 7.4	1.5	2	2	500	715
6	407	624	217	2 - 5	2.9 – 3.1	1.6	2	2	25	260
7	624	657	33	Culvert 9						
8	657	687	30	2 – 5	2.9 – 3.1	1.6	2	2	25	260

### 6.1.2.3 Pipes

A series of non-perforated pipes have been, in the case of Ditch A, and will be, in the case of Ditch B and the pit and 90-day stockpile connectors, installed to capture contact water from the WRSAs, the 90-day stockpile and the open pit. The pipes are sized to capture the runoff from a 1 in 10 year-24 hour event from those facilities. The alignment of the pipe network is shown in Figure 6.1-1.

Seepage from both WRSAs and the 90-day stockpile will report to sumps that will allow for sampling water quality and flow. Due to the planned open pit geometry, water will accumulate in the planned open pit sump and will be pumped up to, and connect with, the pipe network planned for the Platinum Gulch WRSA. Any contact water that accumulates within the sumps will then flow through the pipes to the LDSP for use as process make up water or will be released to Ditch C in accordance with the discharge standards specified in QZ14-041-1. Drawings and specification for the pipe network are provided in Appendix B and C.

### 6.1.3 Open Pit

As summarized above in Section 5.5 and described by BGC (2014 and 2019), due to the relatively low hydraulic conductivity of the rock mass in the open pit area, dewatering wells are not likely to provide a practical or economically efficient means of depressurizing all the open pit slopes. Horizontal drains may be more effective for depressurizing the pit slopes over the life of the mine to maintain stability of the pit walls and to manage pit wall seepage and most of the inflows. The number and location of horizontal drains will be adapted in the field to match conditions observed in the open pit as it is excavated and monitored. These drains could be supplemented with vertical pumping wells in areas of relatively high hydraulic conductivity. The water captured from here will be piped to a connection point with the pipe collecting seepage from the PG WRSA and will be routed along Ditch A where it will flow to the LDSP.

#### 6.1.4 Heap Leach Facility

The HLF valley fill incorporates an embankment (dam) that provides stability to the base of the heap and the stacked ore. The dam also creates an In-Heap Pond leaching configuration that provides storage of pregnant solution within the pore spaces of the ore. The major design components for the HLF, which are incorporated primarily for solution management purposes, include the following:

- a earth/rock filled embankment (dam) and the In-Heap Pond;
- a composite liner system;
- solution recovery wells;
- associated piping network for solution collection and distribution;
- a leak detection and recovery system (LDRS); and
- a down-stream Events Pond.

The heap leach pad consists of two liner systems: an up-gradient liner system and the In-Heap Pond liner system. The single composite liner system in the upper portion of the pad (above the in-heap solution storage area) is comprised of a double-side textured 60 mil linear low-density, polyethylene (LLDPE) liner over a geosynthetic clay liner (GCL) system. The double composite liner system in the lower portion of the pad (forming the in-heap solution storage area) is composed of two discrete layers of LLDPE liner, separated by a layer of geonet material to form the LDRS, over a GCL system.

Process (barren) solution containing cyanide is applied to the ore via a drip irrigation system (buried during winter). The resultant pregnant leach solution (PLS) is captured in the solution collection system and flows to the In-Heap Pond. The PLS is then recovered via a sump using pumps and standpipes. The PLS is then transferred to the ADR plant for gold recovery.

The heap leach pad is designed to contain a network of pipes that will be distributed throughout the limits of the facility at the base of the ore pile. This pipe network is currently constructed under the existing pad of Phase 1A and will be constructed throughout the pad to collect and convey PLS and an infiltrated stormwater to the In-Heap Pond where it will be pumped to the process plant via the solution collection wells.

The downstream Events Pond serves as an overflow containment area that provides additional solution storage in case the In-Heap Pond capacity is exceeded. Any water collected in the events pond will be pumped back to the ADR plant for use as make up water for the barren solution. Prior to construction of the MWTP, the ADR plant is equipped to function as a cyanide destruct circuit in the extreme case that there is excess cyanide solution that needs to be treated.

#### 6.1.5 Mine Water Treatment Plant

Based on the WBM and the WQM, the HLF system is predicted to be in a negative balance during Phase 1, such that the initial water management strategies during start-up through the end of Phase 1 of the HLF, indicate that any additional volume and rate of contact water delivered to the LDSP can be controlled through general water management strategies (e.g., using water for process make-up water) and additional adaptive water management strategies (e.g., use of evaporators and/or snowmakers depending on season, dynamic storage or use of events ponds for temporary storage of process make-up water). Thus, a mine-water treatment plant is not anticipated for Phase 1.

A MWTP will however be constructed later in the Project life to treat a varying combination of site contact water originating from the open pit and WRSAs, as well serving as a back-up to treat excess water from the HLF primarily during the initial drain-down (Phase 6) (Linkan 2014a). The proposed MWTP will be constructed adjacent to the LDSP and just east of the Camp. This site provides good access for chemical delivery trucks and minimizes major pipe runs. The MWTP raw water feed during Phases 2-5 from the LDSP to the plant will be an insulated and heat traced HDPE pipeline. Phase 6 feed water will also be transferred from the ADR to the plant through a double-contained heat traced and insulated HDPE pipeline. The MWTP will be designed to be flexible and expandable to accommodate a wide range in flows.

Contact water quality, MWTP EQSs, and anticipated flow rates from the LDSP to the MWTP were simulated by the WQM (Section 5.3). During Phases 2 to 5 (active mining), the MWTP will treat arsenic (As) and antimony (Sb). Water quality modeling also indicated that during closure Phase 6 (i.e., primarily drain-down of the HLF) 11 parameters may require treatment. These parameters include pH, TSS, nitrate, nitrite, WAD CN, As, Sb, Pb, Hg, Se, and U. Detailed bench testing (Linkan 2014b) for these parameters provided the basis of the MWTP design. Water management strategies during closure are described in the Reclamation and Closure Plan.

The current preliminary MWTP design was based on maximum estimated daily average influent flow rate (primarily during freshet seasons) of 160 L/s (or 576 m<sup>3</sup>/hr). This works out to an instantaneous influent flow of 188 L/s assuming 20.4 hrs/day of continuous treatment operations to achieve the daily average influent flow of 160 L/s. Thus, 3.6 hrs/day will be dedicated to backwashing the microfiltration (MF) units and cleaning. Based on simulated flows and water chemistry the water treatment process to meet the treatment needs is represented in Figure 1 of Linkan (2014a).

During Phases 2-5, the MWTP will treat excess water from the LDSP that exceeds site specific water quality criteria for As and Sb. Raw water from the LDSP will be transferred to the MWTP through an HDPE pipeline to the reaction tank where chemicals will be added to create iron floc for As and Sb adsorption and pH adjustment. The floc will then be pumped to inline plate clarifiers for settling. The decanted water will feed the microfiltration (MF) units where any remaining unsettled solids will be removed. Settled solids from the clarifiers will be pumped to the thickener. Thickened solids will be pressed in a plate and frame filter press and sent to the low pH repository. The press filtrate and thickener decant will be returned to the reaction tank. Captured suspended solids from the MF will also be returned to the reaction tank to be settled in the clarifiers. MF filtrate water will then be pH-adjusted and dechlorinated as needed to meet discharge standards and sent to the permeate tank. Treated water in the permeate tank will then be discharged to Haggart Creek in accordance with site specific water quality criteria. Technical specifications for the MWTP are described in detail in Linkan (2014a).

The MWTP will produce two types of solids during its life of service: low pH solids, and high pH solids. Low pH solids will be generated during both the operational Phases 2-5 and closure Phase 6. These solids consist of the ferric chloride coagulation treatment process solids. The low pH solids will be pressed with a plate and frame filter press and disposed of in a lined repository as described by Engineering Analytics (2014) and situated just southeast and uphill from the MWTP. High pH solids will only be generated during the early closure (Phase 6). This treatment process targets the removal of mercury and other heavy metals. These solids will be pressed with a plate and frame filter press and disposed of within the cover of the HLF.

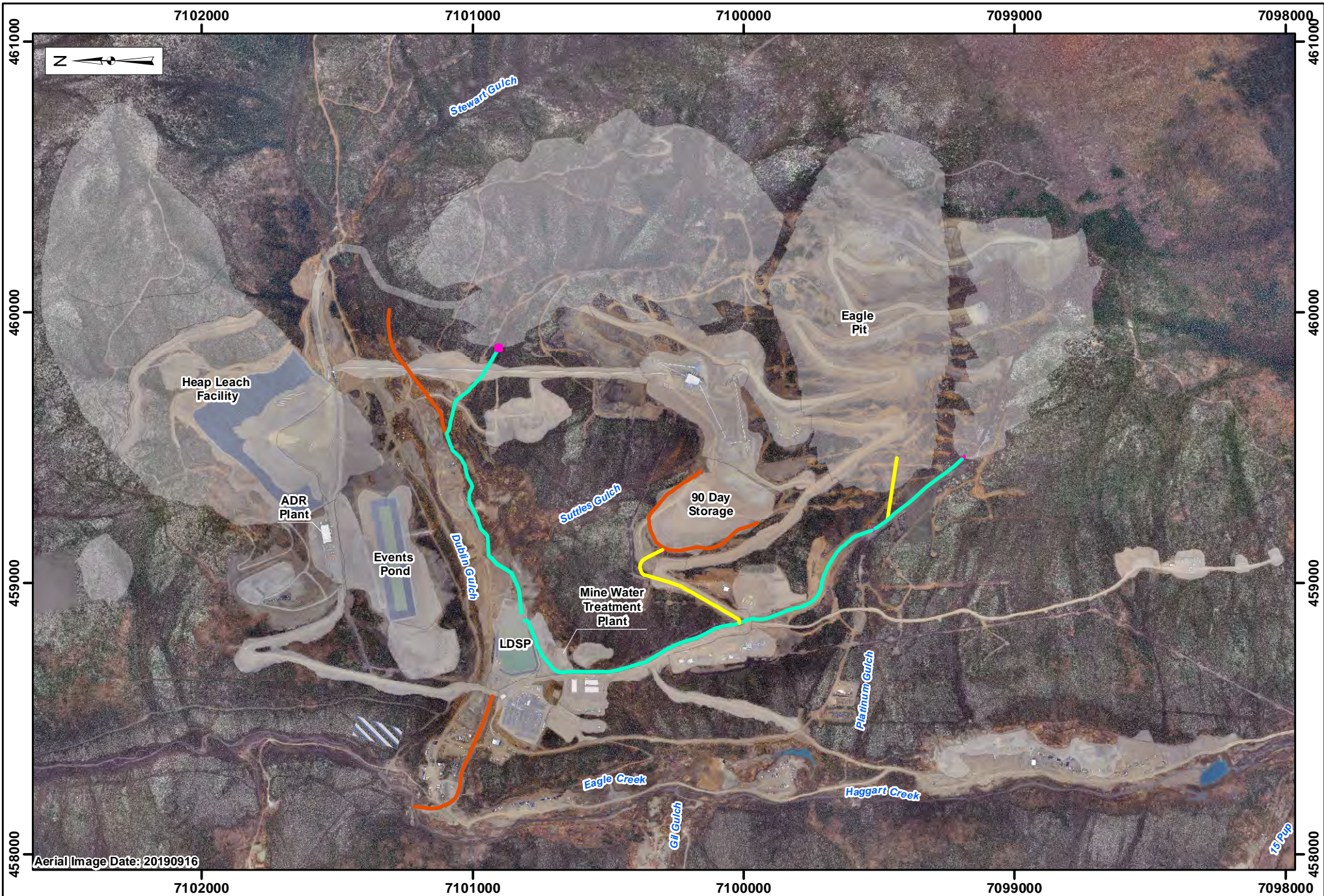

Legend:

- Ditch
- Pipe
- Pipe & Ditch
- Sump
- Culvert
- Reserved Area

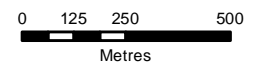

Projection:  
NAD 83 UTM  
Zone 8N

Date:  
2020/01/09

Drawn By:  
HC

Figure:  
6.1-1

**EAGLE GOLD PROJECT  
YUKON TERRITORY**

**Key Water Management  
Facilities Overview**

## **6.2 EROSION AND SEDIMENT CONTROL PLAN IMPLEMENTATION**

This section provides an overview of the current configuration of erosion and sediment control measures based on the BMPs described in Section 4.2 (Sediment and Erosion Control Measures) to support operations. As the Project advances through the operations phase, some of the configuration may be reconsidered based on site observations and areas of activity.

For the purpose of this Plan, the following BMPs will be utilized site wide as necessary.

- Proper staging of construction activities and BMP installations to mitigate erosion and the potential entrainment of sediment.
- Install berms or sediment logs at the top of fill slopes to protect the newly formed slopes from erosion.
- Apply bioengineering techniques for slope stabilization and channel protection as necessary in the sediment basins, ditches, and on any unstable and/or disturbed slopes and surfaces.
- Apply additional BMPs for slope stabilization and channel protection as necessary in the sediment basins, ditches, and on any unstable and/or disturbed slopes and surfaces.
- Install silt fences or sediment logs around the downslope perimeter of material stockpiles to prevent sediment migration downslope.
- Monitor, maintain, repair, or replace the mitigating measures listed above throughout the Project life to ensure BMP effectiveness and efficiency.

### **6.2.1 Erosion and Sediment Control - Current Status**

Erosion and sediment control is ongoing throughout the site to support the overall water management objectives for the Project and to ensure compliance with the regulatory approvals issued for the Project. Revegetation and reseeded work in the areas of the LDSP, Ditches A, B and C in the area of the LDSP, the overland conveyor in the area of the HLF embankment, and the HLF embankment itself have commenced. Additionally, various BMP's have been installed and will be added to, or removed as necessary, during the Operations phase of the Project.

The following measures, in addition to the key water management facilities discussed in section 6.1, are currently in place to stabilize Project areas:

- Silt fences downslope of active mining infrastructure including:
  - Site water management Ditch A
  - Crusher Service Road
  - ADR Process Plant Access Road
  - Substation, gensets, and fuel storage area
  - Waste management facility
  - Crushing and screening areas
  - Topsoil stockpiles A and B
  - HLF embankment area
  - Events Pond and ADR Plant area.
- Silt fences upslope of mining infrastructure including:
  - Overland Conveyor



- Site water management Ditch A
- Lower Dublin South Pond.
- Four sediment basins in topographical low points downslope of the Coarse Ore Stockpile and 90 Day Stockpile areas.
- Exfiltration areas downslope of the following facilities/areas:
  - ADR Process Plant Access Road
  - Events Pond
  - Topsoil Stockpile B.
- Diversion ditches to channel non-contact water away from the following facilities/areas:
  - Upgradient of Phase 1B of the HLF
  - Upgradient of Suttles Gulch
  - Adjacent to the LDSP to intercept unimpacted groundwater seeps.
- Collection ditches to channel contact water from the following facilities/areas (in addition to Ditches A, B and C):
  - ADR Pad
  - Upgradient of Phase 1A of the HLF.
- Rock energy dissipation structures at the end of ditches A, B and C where the ditches either tie into the natural drainage or the LDSP. This protects the receiving area from higher velocity flows released from the diversion ditch.
- Vegetation windrows to act as natural silt fencing downslope of the following facilities/areas:
  - ADR Process Plant Access Road
  - Events Pond
  - 90 Day Stockpile
  - Open Pit access road
  - Camp access road
  - Crusher Pad
  - Substation, gensets, and fuel storage area
  - Waste management facility.

### 6.2.2 Erosion and Sediment Control - Forward Planning

As mining activities on the Project advance, there will be new or increased areas of construction and disturbance that will require the installation of additional erosion and sediment control BMPs. Whilst installation of erosion and sediment control BMPs are best determined based on field observations, the following discussion provides the current conceptual plan for additional erosion and sediment control.

- Install silt fences downslope of mining infrastructure including:
  - HLF eastern access road
  - Eagle Pup WRSA
  - MWTP pad
  - IROSA

## Eagle Gold Project

### Water Management Plan

#### Section 6 Water Management Implementation

---

- Install culverts in Dublin Gulch and Stewart Gulch for the HLF eastern access road;
- Complete construction of Ditch/Pipe B from the EP WRSA to Suttles Gulch;
- Install contact water pipe network for 90-day stockpile and open pit;
- Diversion ditches to channel non-contact water away from the following facilities/areas:
  - Upgradient of Phase 2 of the HLF
  - Upgradient of Phase 3 of the HLF
- Construct sediment basins, exfiltration areas, and rock energy dissipation structures as determined by the Site Services Manager, Technical Services Superintendent and the Environmental Superintendent.

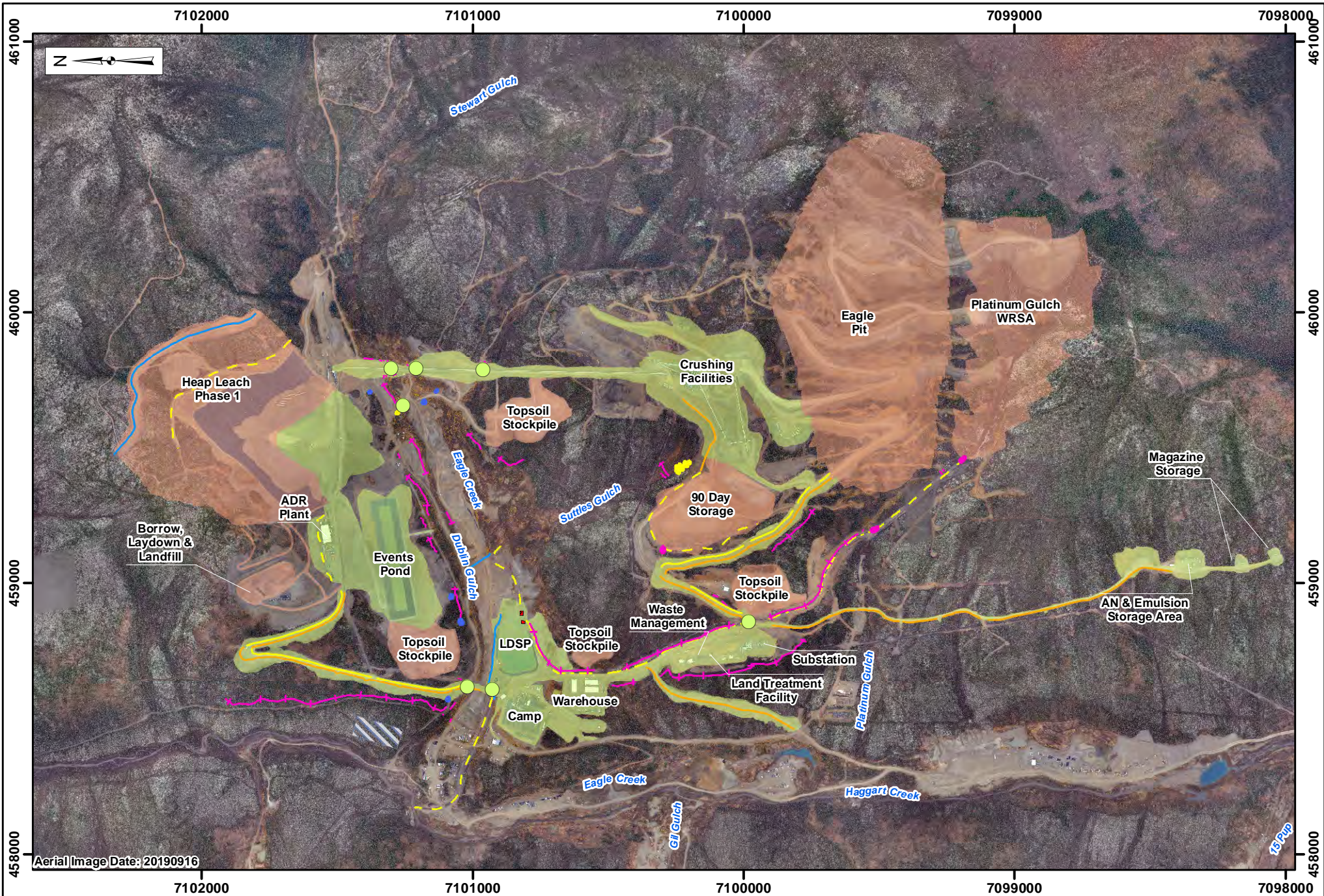

Aerial Image Date: 20190916

Legend:			
Construction Complete	Exfiltration Basin	Culvert	Diversion Ditch
Partial Development	Inlet Basin	Road Ditch	Road Berm
Reserved Area	Sediment Basin	Collection Ditch	Silt Fence
Energy Dissipator		Collection Ditch & Pipe	

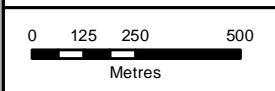

Projection:  
NAD 83 UTM  
Zone 8N  
Date:  
2020/01/09

Drawn By:  
HC  
Figure:  
6.2-1

**EAGLE GOLD PROJECT  
YUKON TERRITORY**

**Installed Erosion &  
Sediment Control BMPs**

## 6.3 SANITARY WASTEWATER MANAGEMENT

In 2018, an on-site sewage disposal system was installed to support the construction and operations camp for the Project. The installation has been fully completed and record drawings and, as per the requirements of the Government of Yukon, Environmental Health Services (EHS), photo documentation of the construction were provided by Tetra Tech and JDS Energy and Mining Inc. and submitted to the Yukon Water Board as required by the Type B Water Use Licence QZ16-016. The ongoing operation, maintenance and surveillance of the camp wastewater system is no longer considered part of this Plan.

## 6.4 WATER USES

Water uses for the project include potable water, dust suppression, wash water, process makeup water and to a significantly lesser extent since major construction activities have been complete, making concrete.

Potable water consumption is estimated in accordance with the projected population of the camp. Consumption rates range from 930 m<sup>3</sup>/month to 3,720 m<sup>3</sup>/month, with the more consumptive months occurring during the ice-free season.

Dust suppression is estimated on the basis of season and number of dry days per month for a typical year. Water for dust suppression water will come from the Lower Dublin South Pond and/or groundwater as needed. Monthly usage ranges from 0 m<sup>3</sup>/month in November through March to approximately 24,800 m<sup>3</sup>/month in the months of June, July, and August. Estimates are calculated from the area of roads to be treated and the average number of dry days per month, reaching a maximum of 20 days/month in dry months.

Wash water includes water to wash trucks and equipment and varies with seasonal activity. Estimated wash water consumption varies from 50 m<sup>3</sup>/month to 250 m<sup>3</sup>/month, with highest projected usage in the summer months.

Makeup water for use within the HLF will be sourced either from the LDSP and/or groundwater as needed. Monthly makeup water requirements are estimated by the HLF WBM to generally decline over the operational life of the facility (as the solution inventory increase) with typical monthly demands of approximately 52,000 m<sup>3</sup> to 78,000 m<sup>3</sup> and maximums of up to 87,000 m<sup>3</sup> during Phase 1 of heap leaching operations. However, even during Phase 1, it is estimated that there will be frequent periods with zero makeup water demand due to solution inventory within the heap, process needs, and natural infiltration (i.e. rainfall or snowmelt).

The HLF WBM also estimates that there will be a modest decrease in Phase 2 as the lined footprint increases and water begins to accumulate in the system. Typical estimated values fall to between 43,000 m<sup>3</sup> to 65,000 m<sup>3</sup> per month and maximums remain at approximately 80,000 m<sup>3</sup>. The frequency at which makeup water demand is zero increases. Makeup water demand is estimated to continue to decline into Phase 3. Although typical modeled values remain between 43,000 m<sup>3</sup> to 65,000 m<sup>3</sup> per month with similar maximum values each month, the frequency at which makeup water demand is zero again increases.

## 6.5 FROZEN MATERIAL MANAGEMENT

Continued earthworks construction and some operational activities of the Project may result in the excavation and exposure of frozen overburden soils, identified as either permafrost or from within the active zone that freezes seasonally. Frozen soils at the project site consist of:

- fine and/or coarse-grained colluvial/alluvial soils or weathered bedrock with little or no ice content,

- coarse-grained sands and gravels with zones of variable ice content,
- fine-grained soils with relatively thin zones (lenses) and low proportions of “excess ice”, and
- fine-grained silty and clayey soils with relatively thick lenses of highly visible “excess ice”.

The term “excess ice” is used to describe ice that occupies a larger pore space in the soil than water in an unfrozen state. When this ice thaws, the resulting water exceeds the water holding capacity of the soil and excess water will be present. Some of the frozen soil with excess ice, hereafter called “ice rich”, may become unstable upon thawing, particularly if it is fine-grained and excess pore water pressure cannot drain readily. Some of these materials, which could potentially be useful in closure activities (e.g., as cover for reclamation) while thawing and draining, may require temporary containment during construction and operation of the mine.

The Frozen Materials Management Plan (FMMP) describes the management of frozen materials, and includes:

- descriptions of existing site conditions pertinent to materials management;
- protocols for characterizing the nature and extent (lateral and vertical) of frozen materials encountered during construction activities including characterizing the presence and extent of excess ice;
- protocols for determining whether encountered frozen material is thaw stable or thaw unstable;
- estimated quantities of frozen materials to be handled during construction distinguishing between material types and different approaches for their management;
- descriptions of appropriate handling requirements for each frozen material type, including protocols for excavation and removal of thaw unstable material from drainage channels, valley walls, etc.;
- design criteria and preliminary engineering for an ice rich overburden storage area;
- construction quality assurance and quality control planning for the ice rich overburden storage area;
- protocols for recording and reporting on the characterization and management of frozen soils (including thaw stable and unstable materials), and
- monitoring plans for stability and associated water management.

Because of the nature of thawing frozen material and the potential for generation of sediment-laden water, the activities associated with the FMMP have been integrated into the overall site Water Management Plan. While the FMMP addresses the identification, field practices and overall management of all frozen materials, including permafrost and ice-rich soils, this Water Management Plan describes best management practices for containing and controlling sediment laden runoff from areas developed in permafrost terrain.

If and when constructed, the Ice Rich Overburden Storage Area (IROSAs) would serve as a dewatering area for any future large volumes of ice-rich material that is excavated during construction and operations. The design (Appendix A in the FMMP) is based on the concept of flow-through berms that permit the exfiltration of excess water to the subsurface while filtering out sediments suspended in the excess pore water. The design consists of five berms to create four storage cells for containing the thawing ice-rich materials. To date, only relatively small volumes of ice-rich material have been encountered and thus construction of the IROSAs has not been necessary.

## **6.6 MAINTENANCE AND MONITORING STRATEGIES**

Regular monitoring of implemented BMPs is essential to the success of the Plan. The Environmental Department will inspect all erosion control measures periodically and after each major runoff-producing rainfall event. Frequent and proper maintenance will allow for prolonged use instead of allowing the facilities to degrade and in need of full replacement.

Silt fences, sediment traps/basins, ditches, culverts, exfiltration areas, and water management basins/ponds will be visually inspected for the following:

- excess sediment build-up;
- structural/physical integrity,
- anticipated wear and tear, and
- snow/ice build-up.

Where certain structures are found to have permafrost or saturated backslopes on the cut slopes, suitable equipment access corridors will be developed to allow for maintenance of those cut slopes.

All key water storage and conveyance structures allow for suitable access to undertake maintenance activities. Maintenance, of the LDSP, sediment basins and other water management structures will be performed as required and may include:

- work required to physically stabilize structures;
- the removal ice or snow to minimize the accumulation within basins/ponds, culverts and water conveyance channels;
- the removal of sediment from ditches, SBs and the LDSP;
- the stabilization and development of adequate drainage from any saturated or permafrost cut slopes
- the repair of any damaged liner, armouring materials or installed erosion control products; and
- the repair or replacement of any damaged or faulty monitoring or control instrumentation or equipment.

For the LDSP, the potential for seepage and settlement need to be considered. Thus, survey monuments will be located along the crest and possibly on the discharge structures. Further, piezometers will be installed through the embankment and equipped with transducers to monitor evolving hydrostatic pressures. Further, flow from the LDSP to Ditch C will be monitored with a V-notch weir installed at the downgradient end of the outflow pipe that discharges to Ditch C. These monitoring locations will be in addition to the routine visual inspections that would need to be conducted and documented as part of periodic inspections. LDSP monitoring protocols will be included in the overall Environmental Monitoring, Surveillance and Adaptive Management Plan.

As surface conditions stabilize, the focus will be less on sediment and erosion control and more on the regular monitoring and maintenance of the stability and condition of water management structures including the main collection ditches, the LDSP and events pond, the ditching and collection of seepage from the WRSAs, the downslope monitoring of the temporary ore stockpile, the reclamation stockpiles and the IROSA. As during construction, monitoring frequencies will be both periodic (as a routine inspection through the year), and after major runoff producing events.

## 7 WATER DISTRIBUTION

Water distribution systems for the Project include fresh water, potable water, process water, and firewater systems. Included in the process water systems are the facilities to contain, transport, and distribute mine-influenced water (MIW). The arrangement of water distribution facilities on the site is depicted in Figure 7.1-1. The figure also shows the general routing of water flows coded by color.



Aerial Image Date: 20190916

Legend:		
	Process Water	
	Process/Fire Water	
	Contact Water	
	Facility	
	Fresh Water	
	Water Discharge	

StrataGold Corporation

0 95 190 380  
Metres

Projection:	NAD 83 UTM Zone 8N
Date:	2020/01/10

Drawn By:	HC
Figure:	7.1-1

**EAGLE GOLD PROJECT  
YUKON TERRITORY**

**Mine Site Water  
Distribution Plan**



## 7.1 FRESH WATER

The freshwater system provides water for freshwater process needs, reagent mixing, wash down water, process make-up, truck washing, fire suppression, and potable water use. Fresh/fire water infrastructure includes a fresh water booster tank and pumps at the well field, water supply pipeline, fresh/fire water tank, and freshwater distribution piping.

The principal source of freshwater is a well constructed through the alluvial valley fill and completed in metasediments. The well is located west of the camp and the Lower Dublin South Pond. Design criteria for the freshwater system are presented in Table 7.1-1.

**Table 7.1-1: Fresh Water Capacities**

Factor	Criterion	Source
Peak freshwater demand	127,000 m <sup>3</sup> per month	KP, 2014
Fresh/Fire water tank capacity – ADR Plant	237 m <sup>3</sup>	Installed Capacity
Fire suppression needs – Camp	125 m <sup>3</sup> /hr for 2 hrs	Estimate 1 standpipe
Fire water storage – Camp	250 m <sup>3</sup>	Installed Capacity
Fire water storage – Crushing Facilities	144 m <sup>3</sup>	Installed Capacity

## 7.2 PROCESS WATER

Process water requirements are primarily associated with make-up water to the Barren Solution Tank and for reagent mixing. Contact water from the LDSP will be a significant source of make-up water to the Barren Solution Tank, supplemented by groundwater as necessary. Make-up water demand is expected to peak during Phase 1 of the HLF. Water for reagent mixing will be supplied by the fresh water tank.

## 7.3 POTABLE

The potable water system is supplied from two wells, one constructed in 2010 and located in the Dublin Gulch alluvial valley and one constructed in 2018 and located within the camp footprint. They both pass through a potable water treatment system in the camp. The water is treated to eliminate bacterial and chemical concerns and stored in a potable water tank (Figure 7.1-1). Potable water is then distributed by booster pumps and piping to the administration building, camp, change house/mine dry, and MWTP (when constructed). Potable water is distributed by truck to the working buildings on site, including the Crushing facilities and ADR building.

## 7.4 FIRE SUPPRESSION

Fire suppression water is provided by fire water tanks located at the ADR Process Plant, at the camp site, and at the crushing facilities. The ADR Process Plant tank is also used for the plant's fresh water and firewater needs, with storage dedicated to the plant and laboratory firewater system. It feeds to hydrant standpipes, and is equipped with jockey pumps and back up diesel jockey pump in case of power failure. The camp and administrative buildings have a dedicated firewater system, also with pump and back up diesel generator power supply in case of power failure. The crushing facility area also has a standalone firewater tank with pump and back up diesel generator jockey pump.

## **7.5 DUST CONTROL**

During operations, most of the water for dust suppression was intended to be pumped into water trucks from the LDSP and used as per licence conditions.

Peak dust suppression demand is projected to occur in the months of June, July, and August and is estimated to be 960 m<sup>3</sup> per day (Knight Piésold 2014). Dust control demand is variable throughout the year.

## 8 REFERENCES

- BGC Engineering Inc. (2012a). Eagle Gold Project - Lower Dublin Gulch Valley Aquifer Tests Project Memorandum, prepared for Victoria Gold Corp. by BGC Engineering Inc., Vancouver BC, September 2012.
- BGC Engineering Inc. (2012b). Eagle Gold Project - Open Pit Pumping Tests Project Memorandum, prepared for Victoria Gold Corp. by BGC Engineering Inc., Vancouver BC, September 2012.
- BGC Engineering Inc. (2013a). Eagle Gold Project - 2012 Groundwater Data Report, prepared for Victoria Gold Corp. by BGC Engineering Inc., Vancouver BC, July 2013.
- BGC Engineering Inc. (2013b). Eagle Gold Project - Production Well Completion Report for PW-BGC12-04, prepared for Victoria Gold Corp by BGC Engineering Inc., Vancouver BC, July 2013.
- BGC (2014). Eagle Gold Project, Numerical Hydrogeologic Model, Final Report; prepared for Victoria Gold Corp. by BGC Engineering Inc., Vancouver BC, April 2014.
- BGC (2017). Eagle Gold Project, Heap Leach Facility Detailed Design, prepared for Victoria Gold Corp. by BGC Engineering Inc., Vancouver BC, November 2017.
- BGC (2019). Eagle Gold Project, Numerical Hydrogeologic Model Update, prepared for Victoria Gold Corp. by BGC Engineering Inc., Vancouver BC, June 2019.
- Canadian Dam Association (CDA 2007). Dam Safety Guidelines. Toronto, Ontario Canada.
- CoreGeo/Watterson (2017). Eagle Gold Project Groundwater Quality Characterization Report prepared by Core Geoscience Services Inc., January 2017
- Hogg, W.D. and Carr, D.A. (1985). Rainfall Frequency Atlas of Canada. Ministry of Environment, Canadian Climate Program. 1985.
- Knight Piésold (2013). Eagle Gold Project Hydrometeorology Report, prepared for Victoria Gold Corp. by Knight Piesold Ltd., Vancouver BC, August 2013.
- Knight Piésold (2014). Eagle Gold Project Site Water Balance Model Report, prepared for Victoria Gold Corp. by Knight Piesold Ltd., Vancouver BC, July 8 2014.
- Linkan (2014a). Engineering Design Report for the Eagle Gold Mine Water Treatment Plan, July 18, 2014.
- Linkan (2014b). Technical Memorandum: Eagle Mine Water Treatment Bench Testing, July 11, 2014.
- Lorax (2013). 2013 Baseline Water Quality Report: Eagle Gold Project, prepared for Victoria Gold Corp. by Lorax Environmental Services Ltd., Vancouver BC, December 2013
- Lorax (2017a), Eagle Gold Hydrometeorology Report, prepared for Victoria Gold Corp. by Lorax Environmental Services Ltd., Vancouver BC, March 13, 2017.
- Lorax (2017b), Baseline Water Quality Report (2016 Update) Eagle Gold Project prepared for Victoria Gold Corp. by Lorax Environmental Services Ltd., Vancouver BC, March 2017.
- Lorax (2019a), Eagle Gold Project Climate Data Report, prepared for Victoria Gold Corp. by Lorax Environmental Services Ltd., Vancouver BC, March 2017.

Section 8 References

---

- Lorax (2019b), Eagle Gold Project Streamflow Monitoring Report - 2018 Update, prepared for Victoria Gold Corp. by Lorax Environmental Services Ltd., Vancouver BC, March 2019.
- Polster, David F. (2002). Soil Bioengineering Techniques for Riparian Restoration. Polster Environmental Services Ltd.
- Rutqvist, J. and Stephansson, O. (2003) The Role of Hydromechanical Coupling in Fractured Rock Engineering. Hydrogeology Journal, 11, pp. 7-40.
- Stantec Ltd. (2011a). Eagle Gold Project – Environmental Baseline Report: Water Quality and Aquatic Biota. June 2011.
- Stantec Ltd. (2011b). Eagle Gold Project – Environmental Baseline Report: Hydrogeology. June 2011.
- Stantec Ltd. (2012a). Eagle Gold Project – Environmental Baseline Report: Water Quality and Aquatic Biota. April 2012.
- Stantec Ltd. (2012b). Eagle Gold Project – Environmental Baseline Data Report: Hydrogeology 2011 – 2012 Update. June 2012.
- USDA (1992). Chapter 18 – Soil Bioengineering for Upland Slope Protection and Erosion Reduction. Engineering Field Handbook. United States Department of Agriculture, Natural Resources Conservation Service. October 1992

# **APPENDIX A**

## **Flocculant Use Plan**

## 1. General

This document provides a basic description of a flocculant use plan that will be implemented, if required, at the SGC Eagle Project. SGC will only use only products from the high molecular weight anionic polyacrylamides (or PAMs) group of flocculants that are non-toxic to fish to settle sediment in the Lower Dublin South Pond (LDSP), sediment control pond.

## 2. Identification and Testing of Appropriate Flocculant(s)

There is a wide range of anionic PAM flocculants available for water clarification however the selection of a specific product is generally informed by site specific soil and water conditions. To ensure that an appropriate product is selected for use on the Project site, a test program will be developed with the earthworks contractor and flocculant suppliers. The test program will commence upon the initial construction of the Lower Dublin South Pond (LDSP) sediment control pond. The testing program will be used to determine the optimal flocculent to meet the discharge criteria for Total Suspended Solids (TSS) (i.e., maximum monthly mean of 15.00 mg/l, and a maximum grab sample of 30.00 mg/L). The test program will specifically be conducted to determine:

- a. The identification of suitable PAM flocculant products that meet the ANSI/NSF Standard 60 for drinking water treatment and is linear (non-cross-linked or resistant to forming complex polymer chains or bonding between adjacent short polymer chains);
- b. An identified maximum dosage for the identified product;
- c. Toxicity testing results for a proposed maximum dosage of the identified PAM product;
- d. A protocol for determining the appropriate dosage rate, which may often be less than the maximum dosage, for the identified product. The protocol will be based on monitoring data (i.e., flow rate, TSS, turbidity) collected routinely and periodically (i.e., likely several times a day during initial establishment to daily once established) from incoming streams (i.e., Ditches A and B).
- e. The Scope of the Testing Program in development is described in Section 2.1

Once the test program is completed, and a suitable PAM flocculant(s) has been determined, a design will be prepared for dosing the flocculant(s) into the feed water going into the LDSP. Material Safety Data Sheets (MSDSs) will be submitted with the design once the PAM products have been identified and tested for performance. Appendix A provides the MSDS for a range of anionic PAM products that may be used to reduce sediment loads in contact water on the Project site.

### 2.1 Scope of Required Testing for Flocculant Determination

Initial testing will be conducted by a selected Flocculant vendor, or third party testing service. The testing will be a standard Laboratory Jar test. The following guidelines will be followed

- Test a minimum of 3 separate polymers covering the tester's recommended polymer formulations for the raw water. The candidate polymers should include as many permutations as practical for the following general polymer characteristics.
- A minimum of five different levels of turbidity will be conducted with equal spacing between the minimum allowable level of 15 mg/l and 1000 mg/l.
- The Jar tests will be conducted for each product at different dosages with the tests run side-by-side, and the results compared to an untreated jar. A minimum of 10 different doses will be conducted for each products.

### 3. Operational Plan for Flocculant System

Should flocculants be required on site to manage elevated TSS concentrations in the discharge from the LDSP or sediment basins, a flocculation system as shown in Figure 1 (assuming the LDSP) will be used. This concept is summarized as follows:

- A centralized flocculation station will prepare a polymer solution from dry polymer powder for in-line injection into Ditch A and Ditch B feeding the LDSP. The maximum batching capacity is expected to be determined during testing;
- The flocculation station and batching and storage tanks will have secondary containment for the expected working volumes of stored liquid;
- It is anticipated that the flocculant storage, station, batching and storage tanks will be assembled into a 40' x8' Sea container converted into mix plant for this application. The plant (if required) will be stationed to the East of the LDSP, before the fore bay;
- Turbidity testing will be conducted daily at regular intervals to determine flocculant addition dosage requirements when there is water to be discharged from the LDSP. Water will be tested at the discharge well of the LDSP, to determine turbidity of the water at the point where it will be released, at the edge of the still well/pump house location of the pond, in the entrance to the main pond, and in the forebay, so that differences in turbidity can be monitored from the entrance to the exit of the water holding area;
- Make-up water for the polymer is expected to be drawn from the secondary portion of the LSDP or from a sediment basin, because the inflow will under most conditions be ephemeral and relatively low. Alternatively, make-up water will be drawn from either a water tank or a nearby water course;
- Protocols for determining the appropriate dosing rates will be prepared from the original testing based on the chosen product. The protocols will be reviewed once in operation to determine the effectiveness and make adjustments to dosing
- The flocculation system will be complete with metering and controls for the mixing and pumping to injection locations; and
- The dry polymer will be shipped to site in 1.0 m<sup>3</sup> super sacks and will be stored indoors.

A standard operating procedure will be developed for the efficient, effective, and controlled addition of the flocculant. The procedure will include, at a minimum, the following:

- Monitoring Requirements (frequency and locations for TSS, turbidity and flow rate);
- Monitoring Methods (sampling and analyses);
- Polymer Handling, Storage and Maintenance;
- Batch Plant Operations and Maintenance (includes make-up water system);
- Periodic Performance Testing to ensure appropriate dosing and uses of identified flocculants; and
- Reporting Protocols and Requirements (for each of the above procedures).

Figure 1 Block Flow Diagram of Flocculation Concept

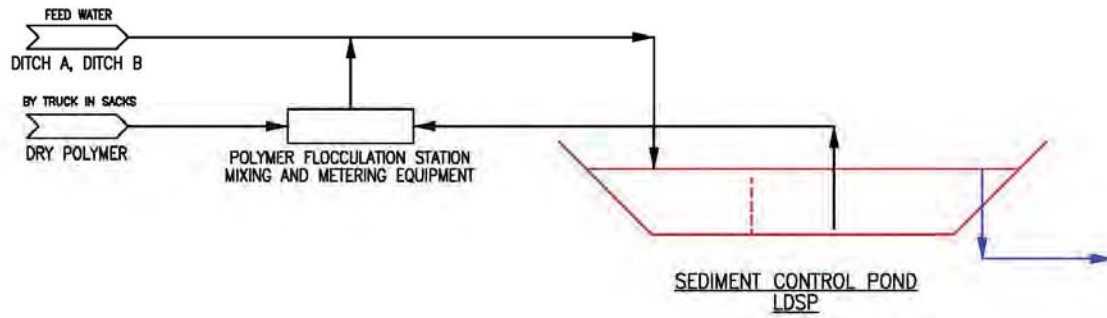

END OF SECTION





# MATERIAL SAFETY DATA SHEET

## PAM A Series

### Section 01 - Product And Company Information

**Product Identifier** ..... PAM A-03, PAM A-103, PAM A-303, PAM A-403, PAM A-503, PAM A-502, PAM A-702, PAM A-703, PAM A-903, PAM A-1003, PAM A-1002, PAM A-1503, PAM A-1803, PAM A-2003

**Product Use** ..... Anionic water treatment polymer.

**Supplier Name** ..... ClearTech Industries Inc.  
1500 Quebec Avenue  
Saskatoon, SK. Canada  
S7K 1V7

**Prepared By** ..... ClearTech Industries Inc. Technical Department  
Phone: (306)664-2522

**24-Hour Emergency Phone** ..... 306-664-2522

### Section 02 - Composition / Information on Ingredients

**Hazardous Ingredients** ..... Contains no hazardous ingredients

**CAS Number** ..... Not applicable

**Synonym (s)** ..... Not available

### Section 03 - Hazard Identification

**Inhalation** ..... Not available

**Skin Contact / Absorption** ..... Irritating to skin

**Eye Contact** ..... Irritating to eyes

**Ingestion** ..... Not available



Exposure Limits..... Nuisance dust: 15mg/m<sup>3</sup>

**Section 04 - First Aid Measures**

**Inhalation**..... Remove victim to fresh air. Give artificial respiration only if breathing has stopped. If breathing is difficult, give oxygen. Seek immediate medical attention.

**Skin Contact / Absorption**..... Remove contaminated clothing. Wash affected area with soap and water. Seek medical attention if irritation occurs or persists

**Eye Contact**..... Flush immediately with water for at least 20 minutes. Forcibly hold eyelids apart to ensure complete irrigation of eye tissue. Seek immediate medical attention

**Ingestion**..... Do not induce vomiting. Consult a physician.

**Additional Information**..... Not available

**Section 05 - Fire Fighting Measures**

**Conditions of Flammability**..... Not available

**Means of Extinction**..... Foam, carbon dioxide, dry powder

**Flash Point**..... Not available

**Auto-ignition Temperature**..... Not available

**Upper Flammable Limit** ..... Not available

**Lower Flammable Limit**..... Not available

**Hazardous Combustible Products**... Nitrogen oxides, carbon monoxide and carbon dioxide.

**Special Fire Fighting Procedures**..... Wear NIOSH-approved self-contained breathing apparatus and protective clothing. When this product comes in contact with water, surfaces become very slippery.



Explosion Hazards..... Not available

**Section 06 - Accidental Release Measures**

Leak / Spill..... Wear appropriate personal protective equipment. Ventilate area. Stop or reduce leak if safe to do so. Prevent material from entering sewers. Do not flush with water. Clean up promptly by sweeping or vacuum. After cleaning, flush away traces with water.

Deactivating Materials..... Not available

**Section 07 - Handling and Storage**

Handling Procedures..... Use proper equipment for lifting and transporting all containers. Use sensible industrial hygiene and housekeeping practices. For good industrial hygiene, avoid contact with skin and eyes, avoid forming dust, and wash hands before breaks and at the end of the workday. Avoid all situations that could lead to harmful exposure.

Storage Requirements..... Keep in a dry, cool place with the container well sealed.

**Section 08 - Personal Protection and Exposure Controls**

**Protective Equipment**

Eyes..... Chemical goggles, full-face shield, or a full-face respirator is to be worn at all times when product is handled. Contact lenses should not be worn; they may contribute to severe eye injury.

Respiratory..... Use dust masks where dust exceeds 15mg/m<sup>3</sup>

Gloves..... Impervious gloves of chemically resistant material (rubber or PVC) should be worn at all times. Wash contaminated clothing and dry thoroughly before reuse.

Clothing..... Body suits, aprons, and/or coveralls of chemical resistant material should be worn at all times. Wash contaminated clothing and dry thoroughly before reuse.

Footwear..... No special footwear is required other than what is mandated at place of work.



**Engineering Controls**

- Ventilation Requirements**..... Mechanical ventilation (dilution or local exhaust), process or personnel enclosure and control of process conditions must be provided in accordance with all fire codes and regulatory requirements. Supply sufficient replacement air to make up for air removed by exhaust systems.
- Other**..... Emergency shower and eyewash must be available and tested in accordance with regulations and be in close proximity.

**Section 09 - Physical and Chemical Properties**

- Physical State**..... Granular solid
- Odor and Appearance**..... Virtually no odor, off white
- Odor Threshold**..... Not available
- Specific Gravity (Water=1)**..... Not available
- Vapor Pressure (mm Hg, 20C)**..... Not available
- Vapor Density (Air=1)**..... Not available
- Evaporation Rate**..... Not available
- Boiling Point**..... Not available
- Freeze/Melting Point**..... Not available
- pH**..... 4-6 @ 5g/L
- Water/Oil Distribution Coefficient**.... Not available
- Bulk Density**..... Not available
- % Volatiles by Volume**..... Not available
- Solubility in Water**..... Complete
- Molecular Formula**..... Not available
- Molecular Weight**..... Not available

**Section 10 - Stability and Reactivity**



- Stability**..... Product is stable
- Incompatibility**..... Oxidizing agents, galvanized metals, mild steel, copper and brass.
- Hazardous Products of Decomposition**.. Thermal decomposition may produce nitrogen oxides.
- Polymerization**..... Will not occur

**Section 11 - Toxicological Information**

- Irritancy**..... Draize tests showed material produces no corneal or iridial effects only slight transitory conjunctival effects similar to those which all granular materials have on conjunctivae.
- Sensitization**..... Testing on guinea pigs showed this material to be non-sensitizing.
- Chronic/Acute Effects**..... A two-year feeding study on rats did not reveal adverse health effects.
- Synergistic Materials**..... Not available
- Animal Toxicity Data**..... LD<sub>50</sub>(oral, rat)= >5000mg/kg
- Carcinogenicity**..... Not considered to be carcinogenic by NTP, IARC, and OSHA.
- Reproductive Toxicity**..... Not available
- Teratogenicity**..... Not available
- Mutagenicity**..... Not available

**Section 12 - Ecological Information**

- Fish Toxicity**..... LC<sub>50</sub>(96 hrs, Fathead minnows)= >1000mg/L
- Biodegradability**..... Not readily biodegradable, this product is not expected to bioaccumulate.
- Environmental Effects**..... The product is not considered toxic to aquatic organisms or harmful to the aquatic environment.

**Section 13 - Disposal Consideration**



**Waste Disposal**..... Dispose in accordance with all federal, provincial, and/or local regulations including the Canadian Environmental Protection Act.

**Section 14 - Transportation Information**

**TDG Classification**

**Class**..... Not regulated

**Group**..... Not regulated

**PIN Number**..... Not regulated

**Other**..... Secure containers (full and/or empty) with suitable hold down devices during shipment and ensure all caps, valves, or closures are secured in the closed position.

**Section 15 - Regulatory Information**

**WHMIS Classification**.....Not a controlled product

**NOTE: THE PRODUCT LISTED ON THIS MSDS HAS BEEN CLASSIFIED IN ACCORDANCE WITH THE HAZARD CRITERIA OF THE CANADIAN CONTROLLED PRODUCTS REGULATIONS. THIS MSDS CONTAINS ALL INFORMATION REQUIRED BY THOSE REGULATIONS.**

**NSF Certification**.....PAM A-503 is certified under ANSI/NSF Standard 60 for coagulation and flocculation at a maximum dosage of 1mg/L.

**Section 16 - Other Information**

**Note:** The responsibility to provide a safe workplace remains with the user. The user should consider the health hazards and safety information contained herein as a guide and should take those precautions required in an individual operation to instruct employees and develop work practice procedures for a safe work environment. The information contained herein is, to the best of our knowledge and belief, accurate. However, since the conditions of handling and use are beyond our control, we make no guarantee of results, and assume no liability for damages incurred by the use of this material. It is the responsibility of the user to comply with all applicable laws and regulations.

**Attention: Receiver of the chemical goods / MSDS coordinator**

As part of our commitment to the Canadian Association of Chemical Distributors (CACD) Responsible Distribution® initiative, ClearTech Industries Inc. and its associated companies require, as a condition of sale, that you forward the attached Material Safety Data Sheet(s) to all affected employees, customers, and end-users. ClearTech will send any available supplementary handling, health, and safety information to you at your request.

If you have any questions or concerns please call our customer service or technical service department.



Preparation Date.....January 21, 2015

**ClearTech Industries Inc. - Locations**

**Corporate Head Office: 1500 Quebec Avenue, Saskatoon, SK, S7K 1V7**

**Phone: 800-387-7503**

**Fax: 888-281-8109**

**www.ClearTech.ca**

<b>Location</b>	<b>Address</b>	<b>Postal Code</b>	<b>Phone Number</b>	<b>Fax Number</b>
Richmond, B.C.	12431 Horseshoe Way	V7A 4X6	800-387-7503	888-281-8109
Port Coquitlam	2023 Kingsway Avenue	V3C 1S9	800-387-7503	888-281-8109
Calgary, AB.	5516E - 40 <sup>th</sup> St. S.E.	T2C 2A1	800-387-7503	888-281-8109
Edmonton, AB.	12020 - 142 <sup>nd</sup> Street	T5L 2G8	800-387-7503	888-281-8109
Saskatoon, SK.	North Corman Industrial Park	S7K 1V7	800-387-7503	888-281-8109
Regina, SK.	555 Henderson Drive	S42 5X2	800-387-7503	888-281-8109
Winnipeg, MB.	340 Saulteaux Crescent	R3J 3T2	800-387-7503	888-281-8109
Mississauga, ON.	355 Admiral Blvd Unit #1	L5T 2N1	800-387-7503	888-281-8109

**24 Hour Emergency Number - All Locations – 1(306) 664-2522**  
**Alternative - 1(800) 387-7503**

**APPENDIX B**  
**As-Built Record Drawings**



# WATER MANAGEMENT PLAN NELPCo EAGLE GOLD MINE, YT



**SITE LOCATION**  
SCALE: NTS

RECORD DRAWING

\\local\hela\Legacy\Vancover\Drafting\Transportation\WTRM\WTRM03037-01 - Eagle Gold Design\_R3 RECORD.dwg [G1.00] January 29, 2018 - 1:29:23 pm (BY: MANG, JUSTIN)

		PROJECT NO.	OFFICE	DES	CKD	REV	DRAWING
		WTRM03037-01	VANC	DH	MH	3	
DATE	SHEET No.	DWN	APP	STATUS			
January 29, 2018	of	JDM	MH	REC			

\\local\hela\legacy\vancover\Drafting\Transportation\WTRM\WTRM03037-01 - Eagle Gold Design\_R3 RECORD.dwg [G1.01] January 29, 2018 - 4:02:25 pm (BY: MANG, JUSTIN)

INDEX OF DRAWINGS	
DWG No.	DESCRIPTION
G1.00	COVER SHEET
G1.01	DRAWING INDEX AND GENERAL NOTES
G1.04	BOREHOLE AND TEST PIT LOCATION PLAN
C1.01	LOWER DUBLIN SOUTH POND - PLAN
C1.02	LOWER DUBLIN SOUTH POND - PROFILES
C1.03	LOWER DUBLIN SOUTH POND - TYPICAL SECTIONS
C1.04	LOWER DUBLIN SOUTH POND - SPILLWAY PLAN AND PROFILE
C1.05	LOWER DUBLIN SOUTH POND - SECTIONS AND DETAILS
C1.06	LOWER DUBLIN SOUTH POND - LOW LEVEL OUTLET AND PUMPHOUSE

**DESIGN CRITERIA:**

- DAM CLASSIFICATION: SIGNIFICANT
- LOWER DUBLIN SOUTH POND CAPACITY (MINIMUM 24 HOUR RETENTION TIME): 1 IN 10 YEAR FLOOD.
- MAIN DAM SPILLWAY: 1 IN 1000 YEAR FLOOD
- COLLECTION DITCHES: 1 IN 10 YEAR FLOOD FOR CAPACITY, 1 IN 100 YEAR FLOOD FOR EROSION
- CULVERT DOWNSTREAM OF THE DAM (H w/D=1.5): 1 IN 1000 YEAR FLOOD
- REST OF CULVERTS (H w/D-1.5): 1 IN 200 YEAR FLOOD

**HYDROLOGY:**

- RECENT PRECIPITATION DATA HAS BEEN REVIEWED AS PART OF THE DESIGN AND FOUND TO BE WITHIN THE NATURAL VARIABILITY.

**DISCLAIMER**

1. These record drawings have been compiled from as-built information provided to Tetra Tech by JDS Energy & Mining Inc. Tetra Tech assumes no responsibility for the accuracy of this information.

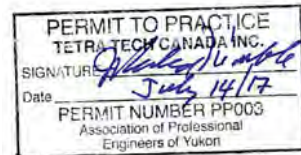

**RECORD DRAWING**

NUM	DATE	DWN	CKD	APR	DESCRIPTION
3	1/29/18	JDM	DH	MH	RECORD DRAWING
2	10/20/17	JDM	DH	MH	DESIGN CHANGE 002
1	7/14/17	JDM	DH	MH	ISSUED FOR CONSTRUCTION
0	7/6/17	JDM	DH	MH	ISSUED FOR CONSTRUCTABILITY REVIEW



CLIENT

WATER MANAGEMENT PLAN NELPCo EAGLE GOLD MINE , YT					
DRAWING INDEX AND GENERAL NOTES					
PROJECT NO.	OFFICE	DES	CKD	REV	DRAWING
WTRM03037-01	VANC	DH	MH	3	G1.01
DATE	SHEET No. of	DWN	APP	STATUS	
January 29, 2018		JDM	MH	REC	

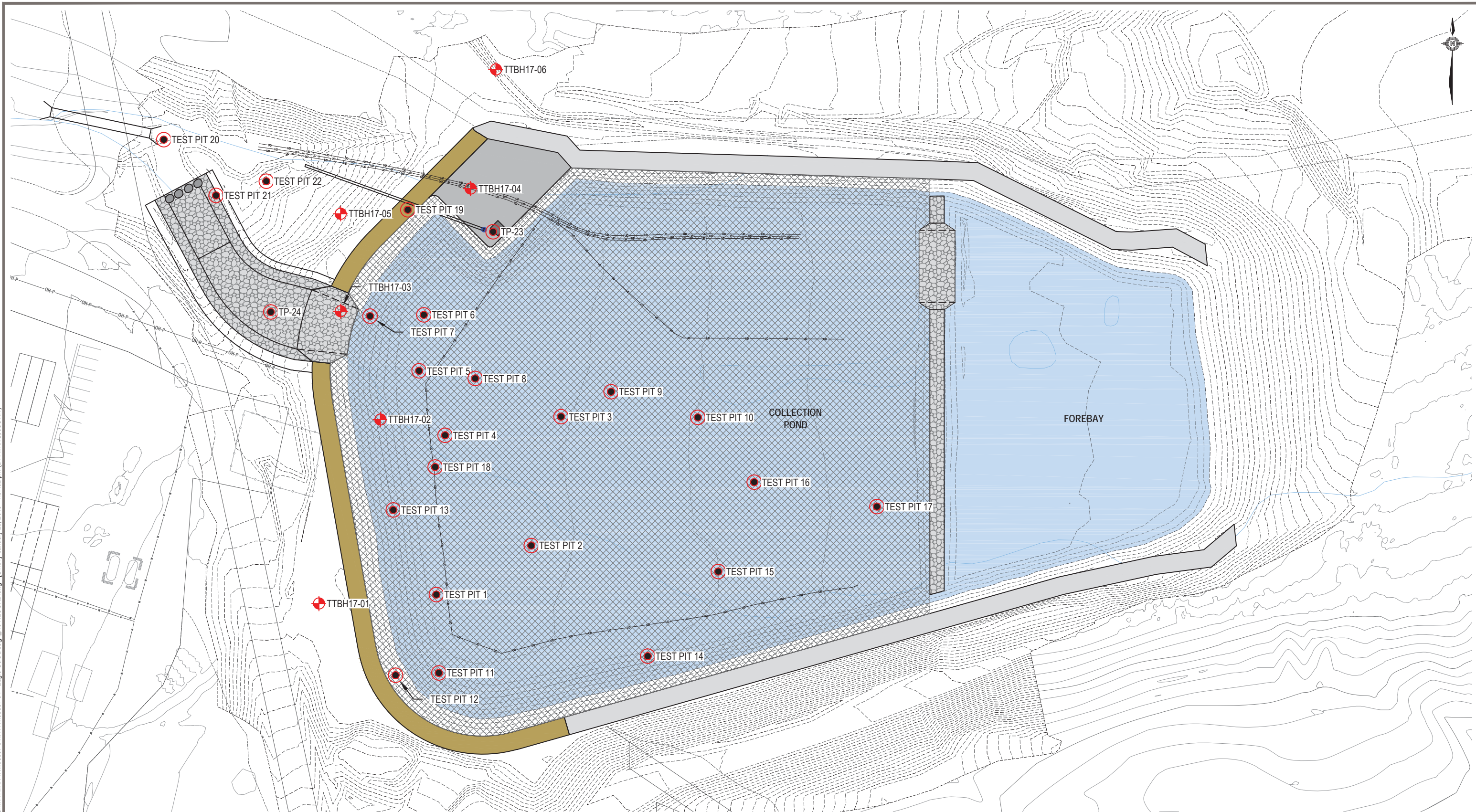

W:\local\heta\Legacy\Drawings\Transportation\WTRM\WTRM03037-01\WTRM03037-01 - Eagle Gold Design - R3 RECORD.dwg [G1.04] January 29, 2018 - 1:37:02 pm (BY: MANG, JUSTIN)

- LEGEND**
- Design Major Contours (2 m)
  - Design Minor Contours (0.5 m)

**NOTES**

PERMIT TO PRACTICE  
 TETRA TECH CANADA INC.  
 SIGNATURE: *[Signature]*  
 Date: *July 14/17*  
 PERMIT NUMBER PPO03  
 Association of Professional Engineers of Yukon

**RECORD DRAWING**

NUM	DATE	DWN	CKD	APR	DESCRIPTION
2	1/29/18	JDM	DH	MH	RECORD DRAWING
1	10/10/17	JDM	DH	MH	ADDED TEST PIT LOCATIONS
0	7/14/17	JDM	DH	MH	ISSUED FOR CONSTRUCTION



CLIENT

**StrataGold Corporation**

**TETRA TECH**

**WATER MANAGEMENT PLAN**  
**NELPCo EAGLE GOLD MINE, YT**

**BOREHOLE AND TEST PIT LOCATION PLAN**

PROJECT NO. WTRM03037-01	OFFICE VANC	DES DH	CKD MH	REV 2	DRAWING G1.04
DATE January 29, 2018	SHEET No. of	DWN JDM	APP MH	STATUS REC	

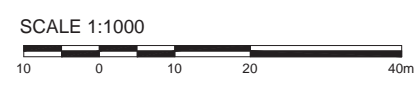

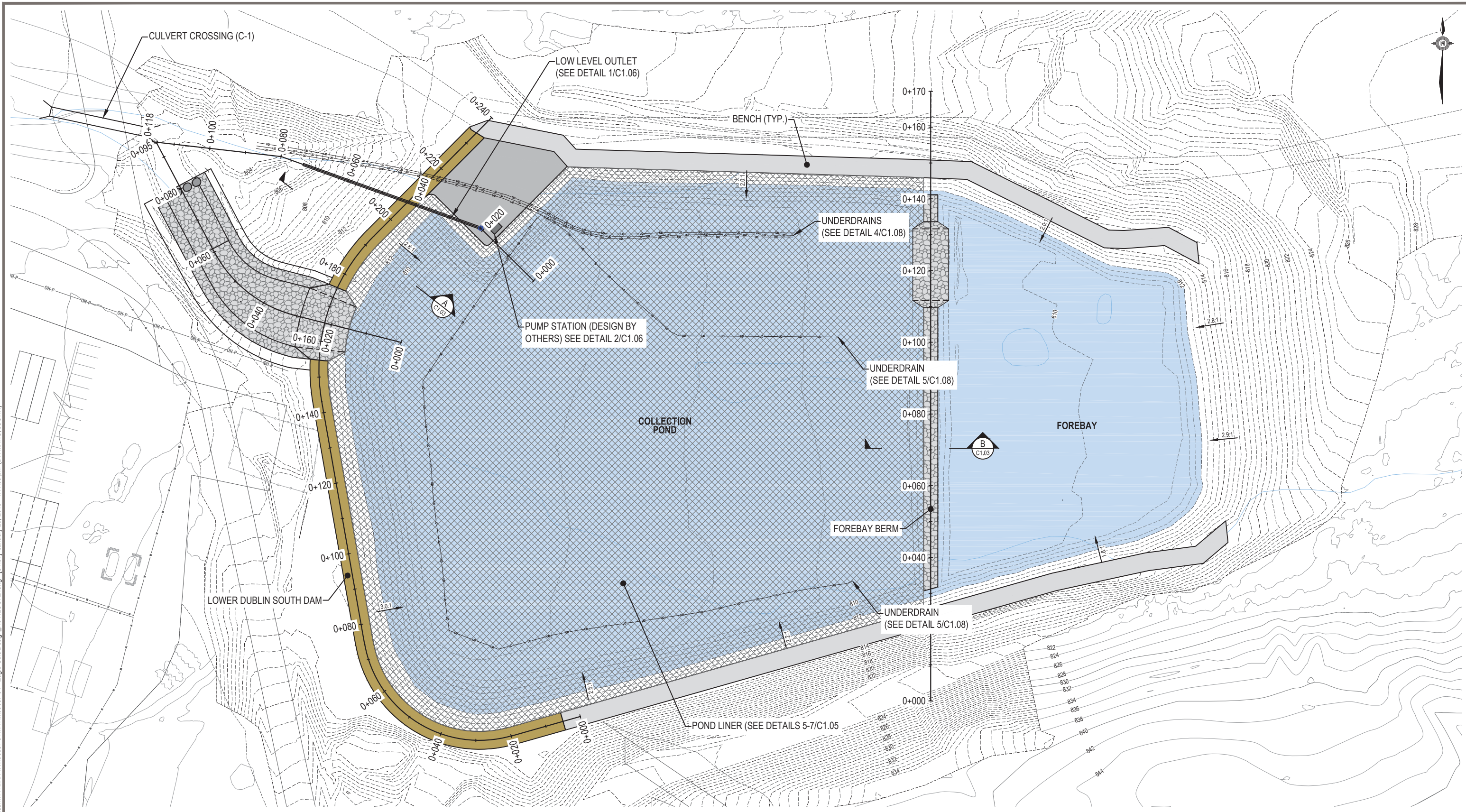

I:\local\beta\Legacy\Vancover\Drafting\Transportation\WTRM\WTRM03037-01 - Eagle Gold Design - R3 RECORD.dwg [C1.01] January 29, 2018 - 1:41:05 pm (BY: MANG, JUSTIN)

- LEGEND**
- Design Major Contours (2 m)
  - Design Minor Contours (0.5 m)

**NOTES**

PERMIT TO PRACTICE  
 TETRA TECH CANADA INC.  
 SIGNATURE: *[Signature]*  
 Date: *July 14/17*  
 PERMIT NUMBER PPO03  
 Association of Professional Engineers of Yukon

**RECORD DRAWING**

NUM	DATE	DWN	CKD	APR	DESCRIPTION
4	1/29/18	JDM	DH	MH	RECORD DRAWING
3	10/20/17	JDM	DH	MH	DESIGN CHANGE 002
2	9/29/17	JDM	DH	MH	DESIGN CHANGE 001
1	7/14/17	JDM	DH	MH	ISSUED FOR CONSTRUCTION
0	7/6/17	JDM	DH	MH	ISSUED FOR CONSTRUCTABILITY REVIEW

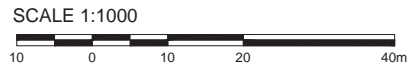

CLIENT

**StrataGold Corporation**

**TETRA TECH**

**WATER MANAGEMENT PLAN**  
**NELPCo EAGLE GOLD MINE, YT**

**LOWER DUBLIN SOUTH POND PLAN**

PROJECT NO. WTRM03037-01	OFFICE VANC	DES DH	CKD MH	REV 4	DRAWING C1.01
DATE January 29, 2018	SHEET No. of	DWN JDM	APP MH	STATUS REC	

\\l:\local\heta\Legacy\Vancover\Drafting\Transportation\WTRM\WTRM03037-01 - Eagle Gold Design\_R3 RECORD.dwg [C1.02] January 29, 2018 - 1:49:12 pm (BY: MANG, JUSTIN)

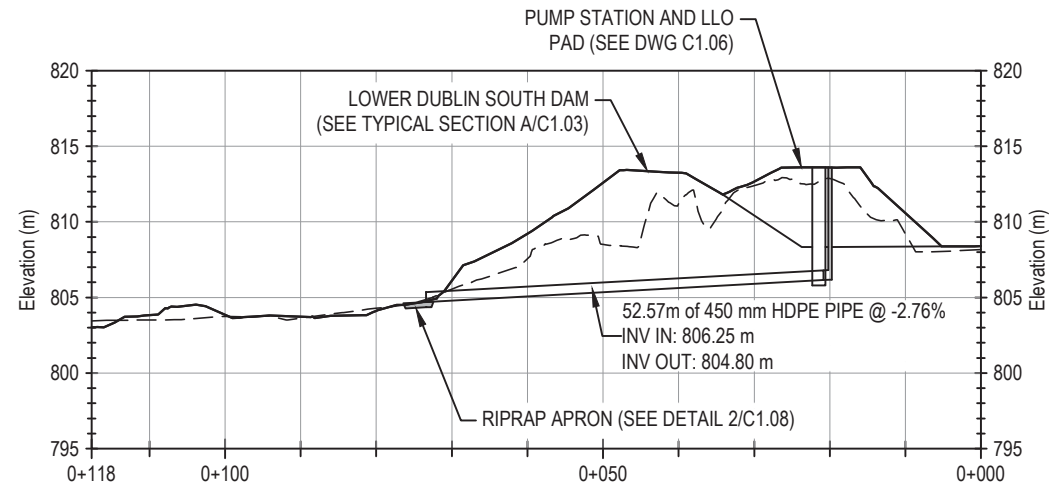

**1** LOW LEVEL OUTLET PROFILE  
C1.02 SCALE: 1:1000 (HORIZ.) 1:500 (VERT)

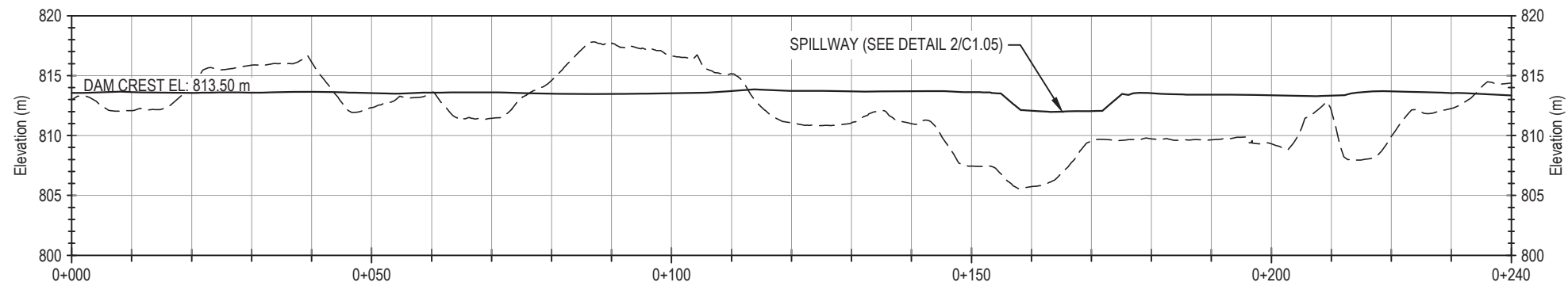

**2** DAM CENTERLINE PROFILE  
C1.02 SCALE: 1:1000 (HORIZ.) 1:500 (VERT)

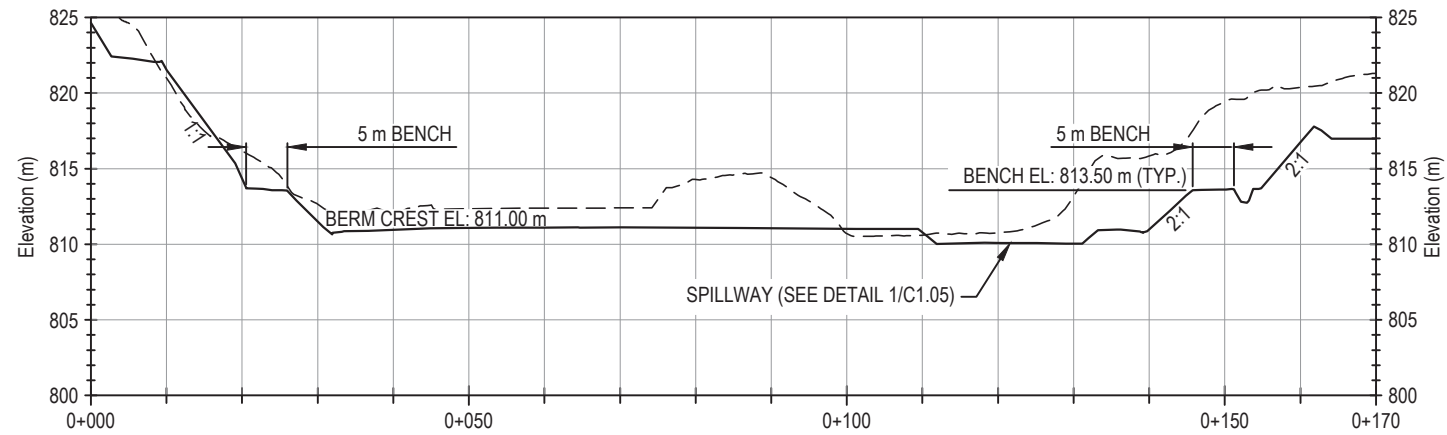

**3** BERM CENTERLINE PROFILE  
C1.02 SCALE: 1:1000 (HORIZ.) 1:500 (VERT)

**NOTE:**

1. PROFILE VIEWS ARE EXAGGERATED BY TWO TIMES VERTICALLY.

**LEGEND**

- Existing Ground
- Proposed Ground

**NOTES**

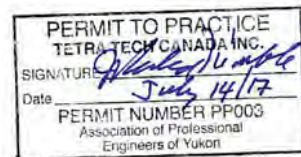

**RECORD DRAWING**

NUM	DATE	DWN	CKD	APR	DESCRIPTION
4	1/29/18	JDM	DH	MH	RECORD DRAWING
3	10/20/17	JDM	DH	MH	DESIGN CHANGE 002
2	9/29/17	JDM	DH	MH	DESIGN CHANGE 001
1	7/14/17	JDM	DH	MH	ISSUED FOR CONSTRUCTION
0	7/6/17	JDM	DH	MH	ISSUED FOR CONSTRUCTABILITY REVIEW



**CLIENT**



**WATER MANAGEMENT PLAN  
NELPCo EAGLE GOLD MINE, YT**

**LOWER DUBLIN SOUTH POND  
PROFILES**

PROJECT NO. WTRM03037-01	OFFICE VANC	DES DH	CKD MH	REV 4	DRAWING C1.02
DATE January 29, 2018	SHEET No. of	DWN JDM	APP MH	STATUS REC	

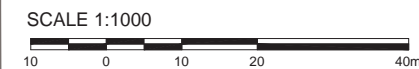

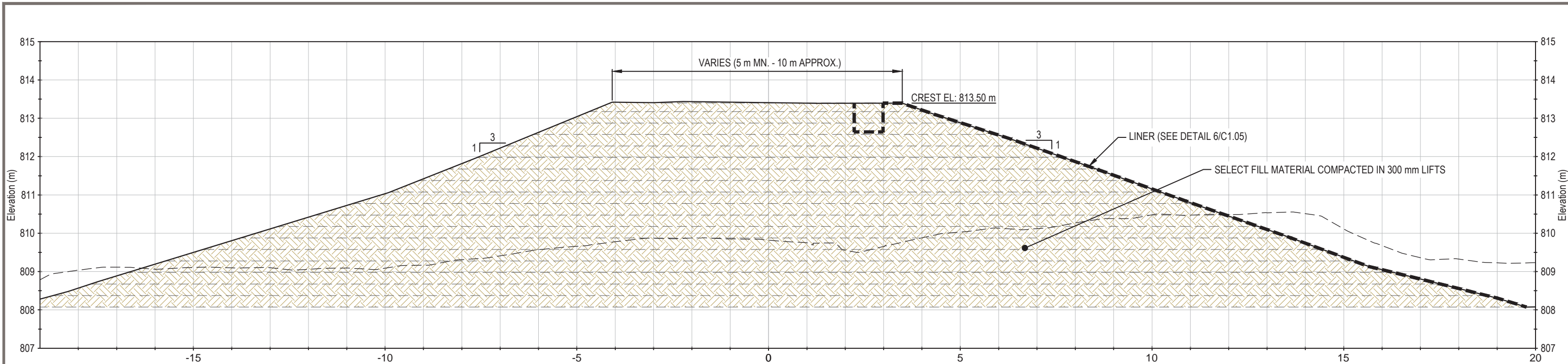

**A** TYPICAL DAM SECTION  
C1.03 SCALE: 1:100

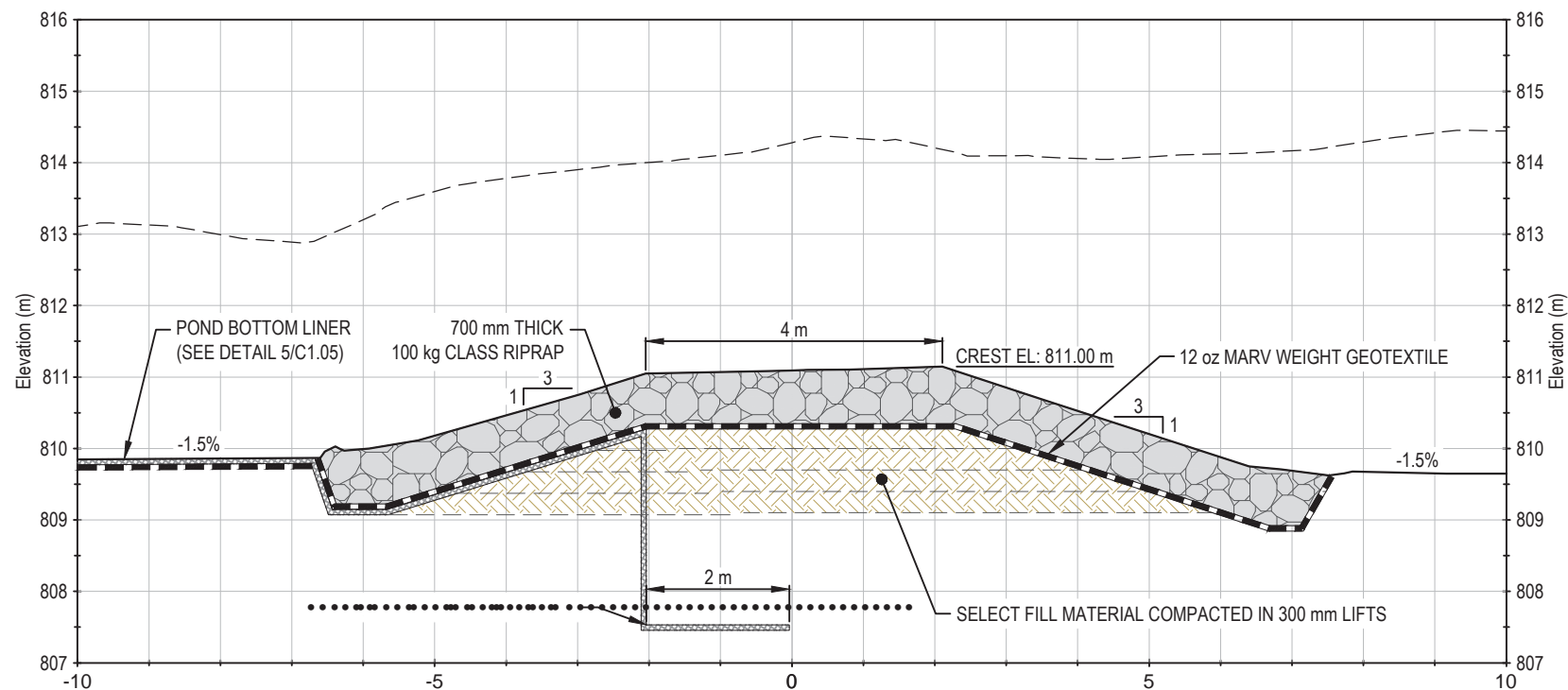

**B** TYPICAL FOREBAY EMBANKMENT SECTION  
C1.03 SCALE: 1:100

**LEGEND**  
 - - - Existing Ground  
 — Proposed Ground

**NOTES**



**RECORD DRAWING**

NUM	DATE	DWN	CKD	APR	DESCRIPTION
4	1/29/18	JDM	DH	MH	RECORD DRAWING
3	10/20/17	JDM	DH	MH	DESIGN CHANGE 002
2	9/29/17	JDM	DH	MH	DESIGN CHANGE 001
1	7/14/17	JDM	DH	MH	ISSUED FOR CONSTRUCTION
0	7/6/17	JDM	DH	MH	ISSUED FOR CONSTRUCTABILITY REVIEW



CLIENT

**WATER MANAGEMENT PLAN**  
**NELPCo EAGLE GOLD MINE, YT**

**LOWER DUBLIN SOUTH POND**  
**TYPICAL SECTIONS**

PROJECT NO. WTRM03037-01	OFFICE VANC	DES DH	CKD MH	REV 4	DRAWING C1.03
DATE January 29, 2018	SHEET No. of	DWN JDM	APP MH	STATUS REC	

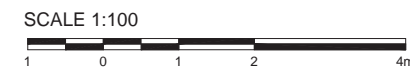

I:\local\heta\Legacy\Drawings\Drafting\Transportation\WTRM\WTRM03037-01 - Eagle Gold Design\_R3 RECORD.dwg [C1.03] January 29, 2018 - 3:46:46 pm (BY: MANG, JUSTIN)

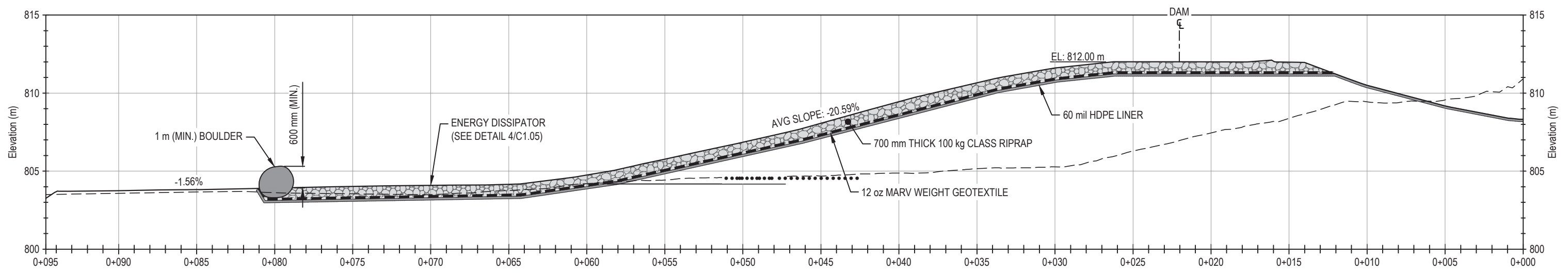
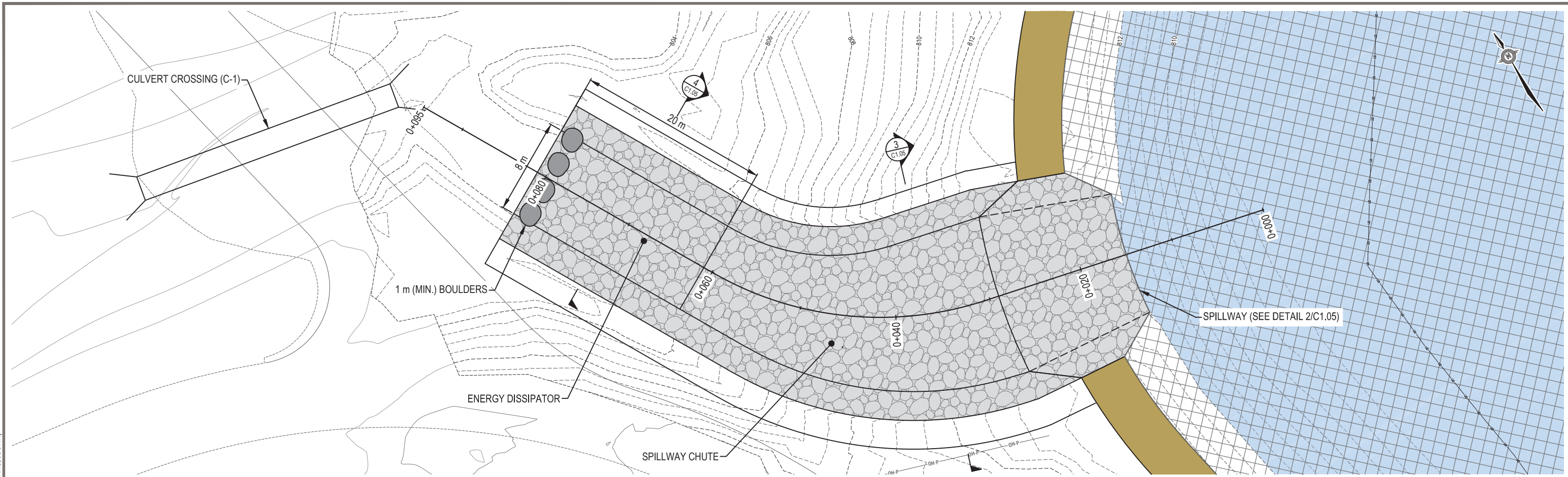

**LEGEND**

---	Existing Ground
—	Proposed Ground

**NOTES**

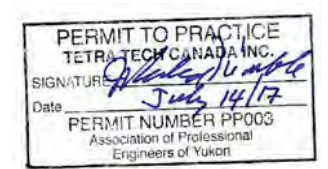

**ISSUED FOR CONSTRUCTION**

NUM	DATE	DWN	CKD	APR	DESCRIPTION
4	1/29/18	JDM	DH	MH	RECORD DRAWING
3	10/20/17	JDM	DH	MH	DESIGN CHANGE 002
2	9/29/17	JDM	DH	MH	DESIGN CHANGE 001
1	7/14/17	JDM	DH	MH	ISSUED FOR CONSTRUCTION
0	7/6/17	JDM	DH	MH	ISSUED FOR CONSTRUCTABILITY REVIEW



CLIENT

<b>WATER MANAGEMENT PLAN NELPCo EAGLE GOLD MINE, YT</b>					
<b>LOWER DUBLIN SOUTH POND SPILLWAY PLAN AND PROFILE</b>					
PROJECT NO. WTRM03037-01	OFFICE VANC	DES DH	CKD MH	REV 4	DRAWING C1.04
DATE January 29, 2018	SHEET No. of	DWN JDM	APP MH	STATUS REC	

SCALE AS SHOWN

\\local\heta\legacy\vancover\Drafting\Transportation\WTRM\WTRM03037-01\WTRM03037-01 - Eagle Gold Design - R3 RECORD.dwg [C1.04] January 29, 2018 - 1:50:48 pm (BY: MANG, JUSTIN)

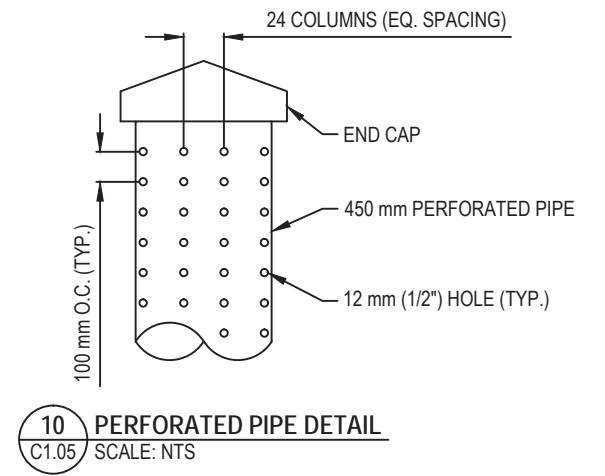
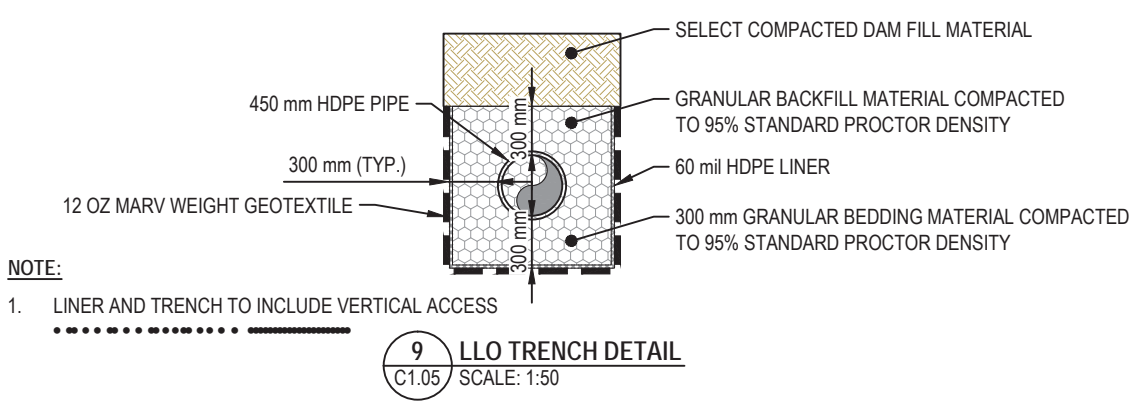
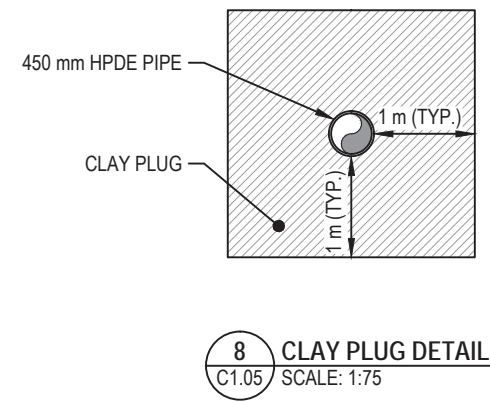
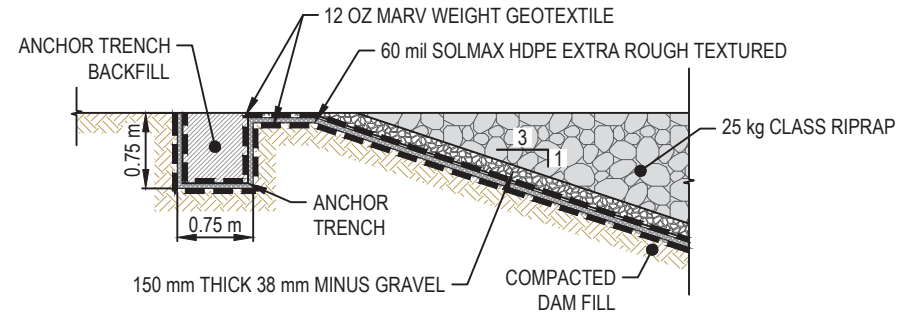
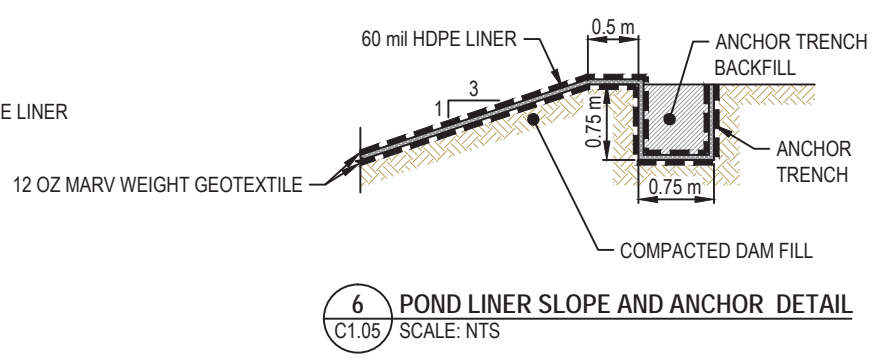
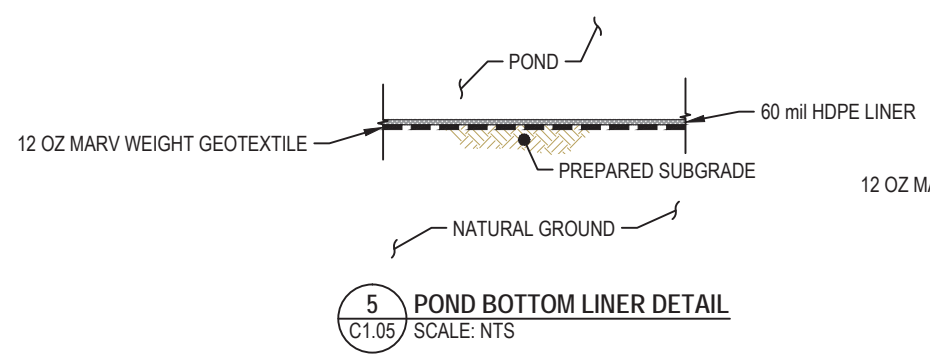
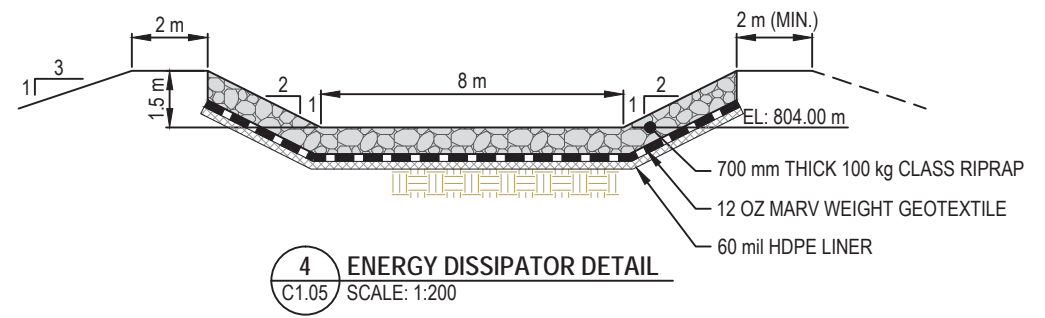
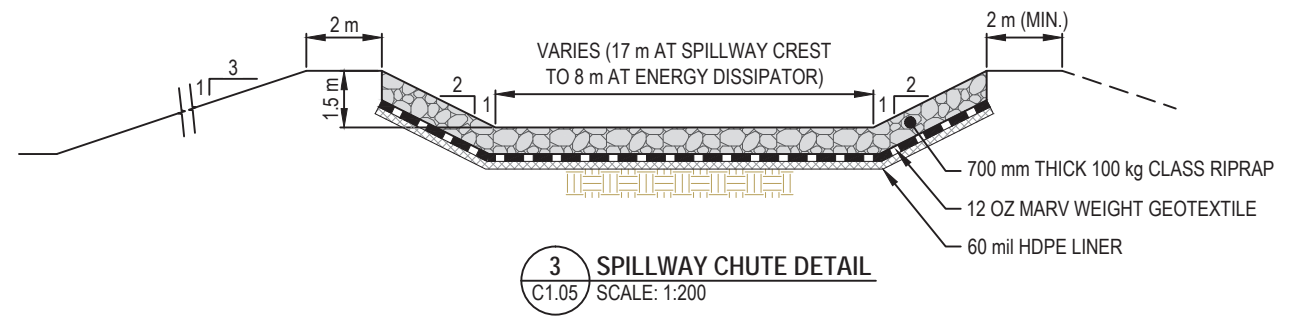
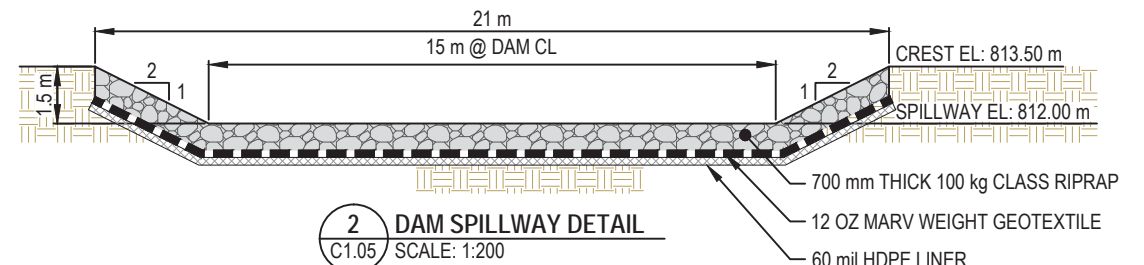
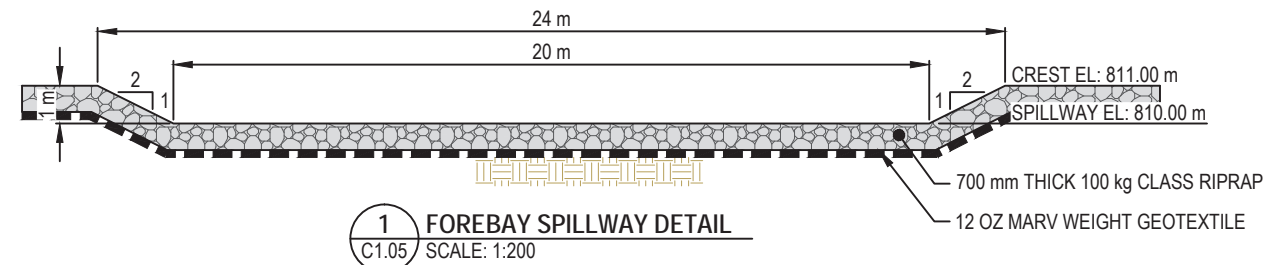

NOTE:  
1. LINER AND TRENCH TO INCLUDE VERTICAL ACCESS

LEGEND

NOTES

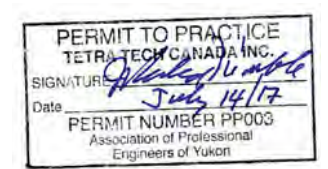

RECORD DRAWING

NUM	DATE	DWN	CKD	APR	DESCRIPTION
4	1/29/18	JDM	DH	MH	RECORD DRAWING
3	10/20/17	JDM	DH	MH	DESIGN CHANGE 002
2	9/29/17	JDM	DH	MH	DESIGN CHANGE 001
1	7/14/17	JDM	DH	MH	ISSUED FOR CONSTRUCTION
0	7/6/17	JDM	DH	MH	ISSUED FOR CONSTRUCTABILITY REVIEW



WATER MANAGEMENT PLAN NELPCo EAGLE GOLD MINE, YT					
LOWER DUBLIN SOUTH POND SECTIONS & DETAILS					
PROJECT NO.	OFFICE	DES	CKD	REV	DRAWING
WTRM03037-01	VANC	DH	MH	4	C1.05
DATE	SHEET No. of	DWN	APP	STATUS	REC
January 29, 2018		JDM	MH	REC	



I:\local\beta\Legacy\Vancover\Drafting\Transportation\WTRM03037-01 - Eagle Gold Design - R3 RECORD.dwg [C1.05] January 29, 2018 - 3:56:49 pm (BY: MANG, JUSTIN)



\\lcal\heta\Legacy\Vancover\Drafting\Transportation\WTRM\WTRM03037-01 - Eagle Gold Design - R3 RECORD.dwg [C1.06] January 29, 2018 - 2:03:24 pm (BY: MANG, JUSTIN)

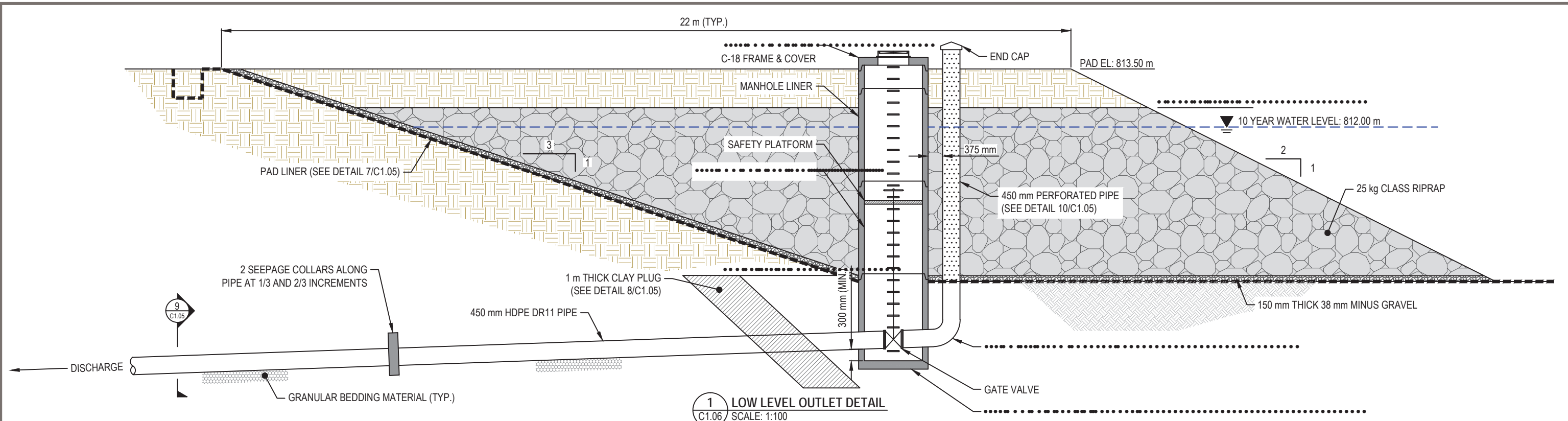

**1 LOW LEVEL OUTLET DETAIL**  
C1.06 SCALE: 1:100

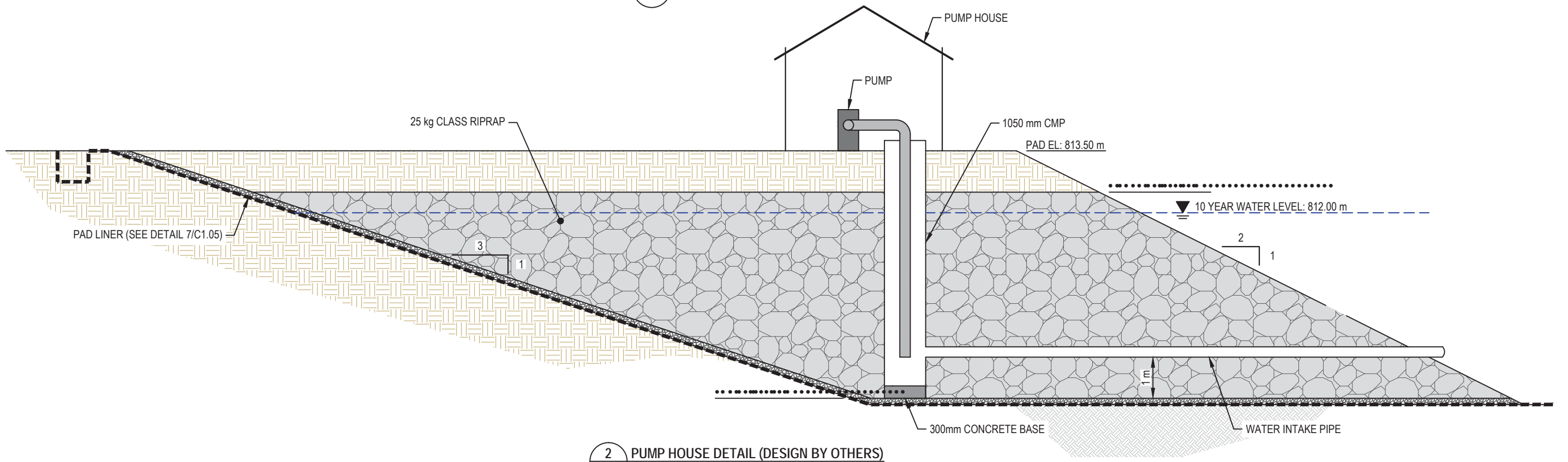

**2 PUMP HOUSE DETAIL (DESIGN BY OTHERS)**  
C1.06 SCALE: 1:100

**LEGEND**

**NOTES**

SCALE 1:100

PERMIT TO PRACTICE  
TETRA TECH CANADA INC.  
SIGNATURE: *[Signature]*  
Date: *July 14/17*  
PERMIT NUMBER PPO03  
Association of Professional Engineers of Yukon

**RECORD DRAWING**

NUM	DATE	DWN	CKD	APR	DESCRIPTION
3	1/29/18	JDM	DH	MH	RECORD DRAWING
2	9/29/17	JDM	DH	MH	DESIGN CHANGE 001
1	7/14/17	JDM	DH	MH	ISSUED FOR CONSTRUCTION
0	7/6/17	JDM	DH	MH	ISSUED FOR CONSTRUCTABILITY REVIEW

CLIENT

**StrataGold Corporation**

**TETRA TECH**

PROFESSIONAL  
YUKON  
MAURIGIO HERRERA  
TERRITORY  
ENGINEER

WATER MANAGEMENT PLAN  
NELPCo EAGLE GOLD MINE, YT

LOWER DUBLIN SOUTH POND  
LOW LEVEL OUTLET AND PUMP HOUSE

PROJECT NO. WTRM03037-01	OFFICE VANC	DES DH	CKD MH	REV 3	DRAWING C1.06
DATE January 29, 2018	SHEET No. of	DWN JDM	APP MH	STATUS REC	

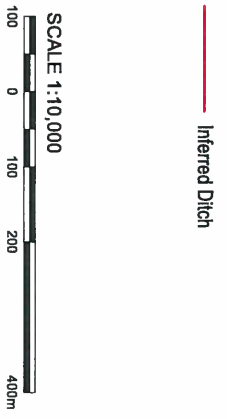

LEGEND

Inferred Ditch

NOTES

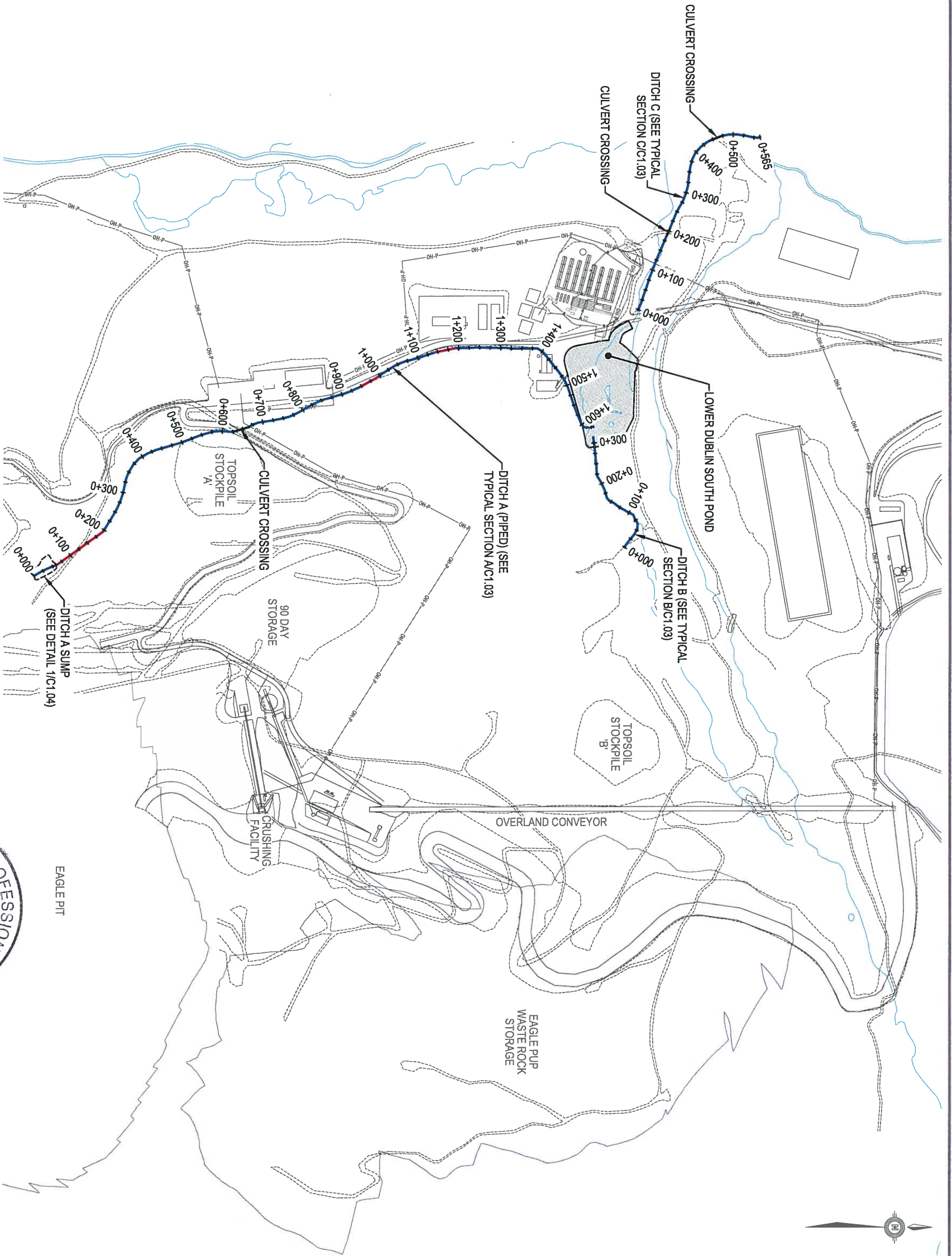

RECORD DRAWING

NUM	DATE	DESIGN	CHECK	RECORD	REVISIONS
0	5/17/19	JHM	MH	MH	RECORD DRAWING

**PROFESSIONAL**

YUKON TERRITORY  
MAURICIO HERRERA  
5/17/19  
ENGINEER

**StrataGold Corporation**

**TETRA TECH**

PROJECT NO.		OFFICE	DES	CAD	REV	DRAWING	
WTRM03037-01		VANC.	MH	MH	0	C1.00	
DATE	SHEET No.	DWN	APP	STATUS			
May 17, 2019		JHM	MH	REC			

WATER MANAGEMENT PLAN  
NELPco EAGLE GOLD MINE, YT  
**DITCH DESIGN PLAN**

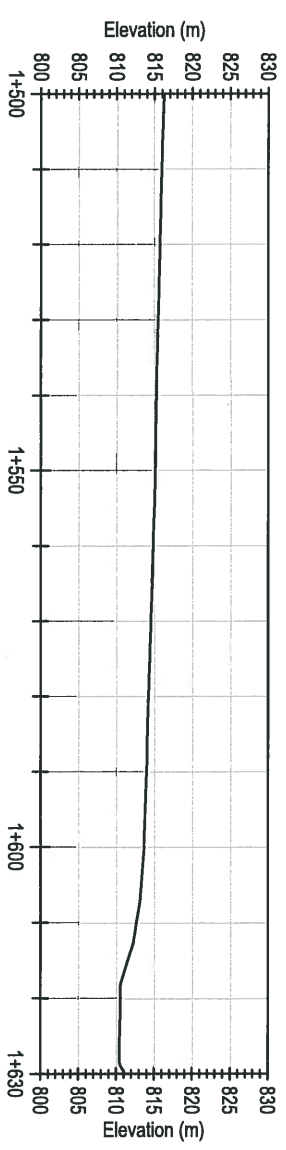
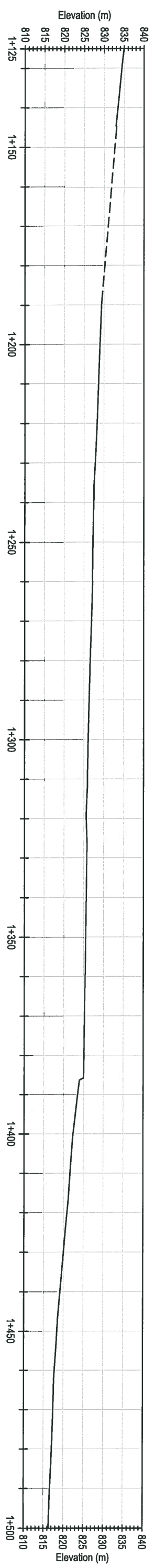
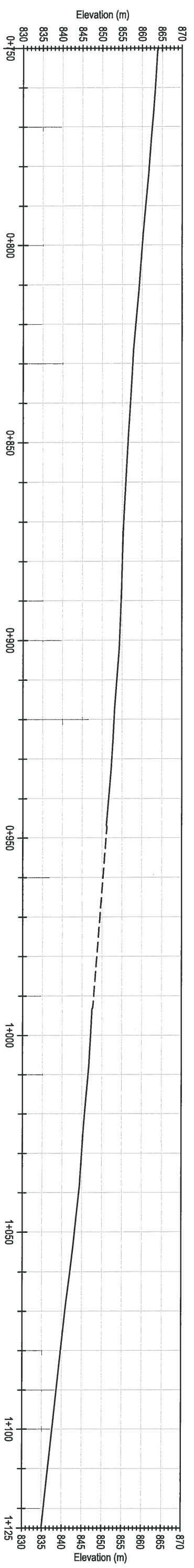
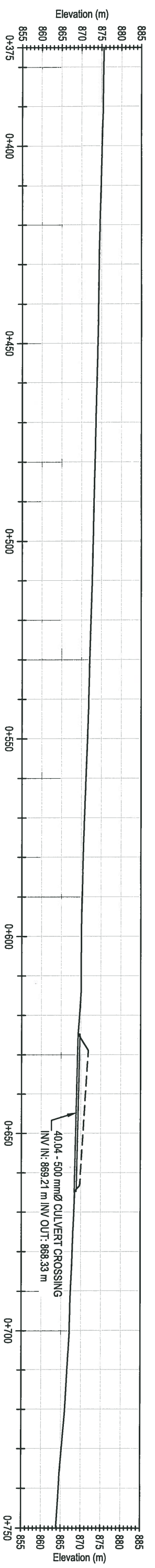
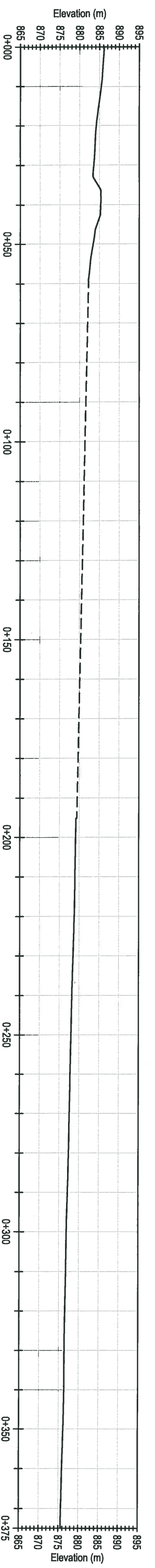

**A** DITCH PROFILE  
C1.01 SCALE: 1:1000

**LEGEND**  
 — As Built Profile  
 - - - Inferred Profile (See Note 2)

**NOTES**  
 1. As Built survey completed on April 14, 2019.  
 2. Ditch profile is inferred due to ice presence at time of survey.

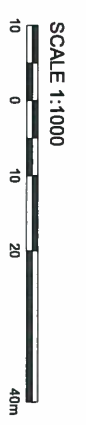

**RECORD DRAWING**

NUM	DATE	BY	CHK	APP	DESCRIPTION
0	5/17/19	JDM	MH	MH	RECORD DRAWING

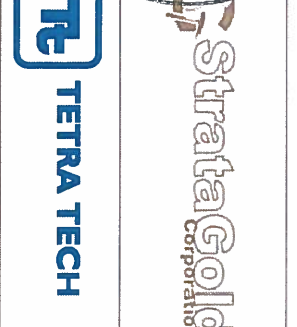

<b>PROJECT NO.</b>		<b>OFFICE</b>		<b>DES</b>		<b>CND</b>		<b>REV</b>		<b>DRAWING</b>
WTRM03037-01		VAN/C		MH		MH		0		
<b>DATE</b>		<b>SHEET No.</b>		<b>DWN</b>		<b>APP</b>		<b>STATUS</b>		<b>C1.01</b>
May 17, 2019		of		JDM		MH		REC		

**WATER MANAGEMENT PLAN**  
**NELPOO EAGLE GOLD MINE, YT**

**DITCH PROFILES**

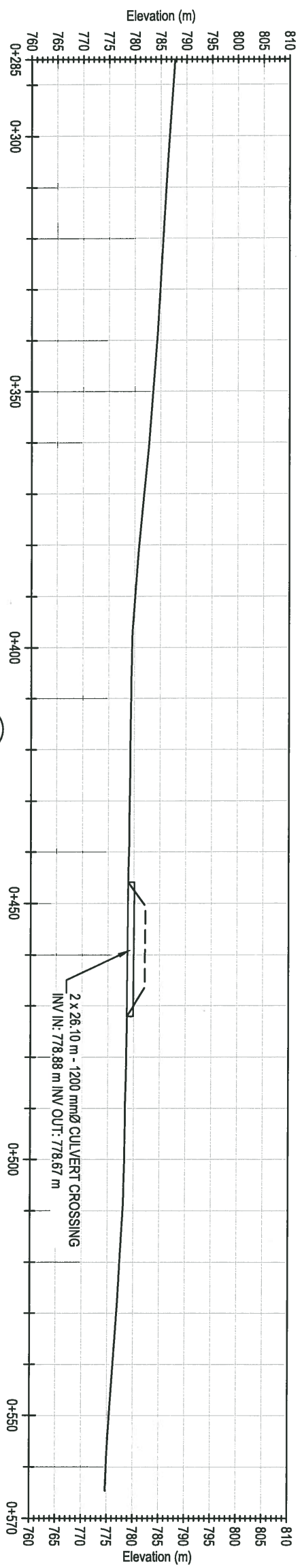
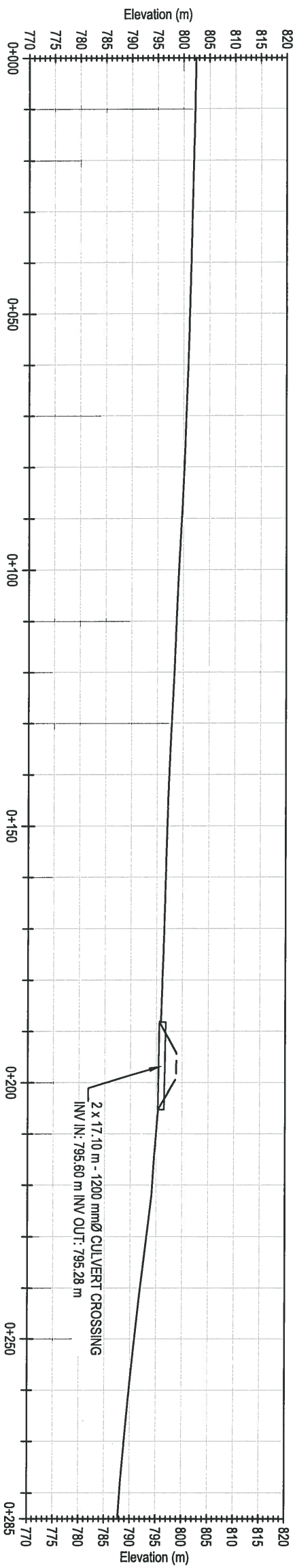
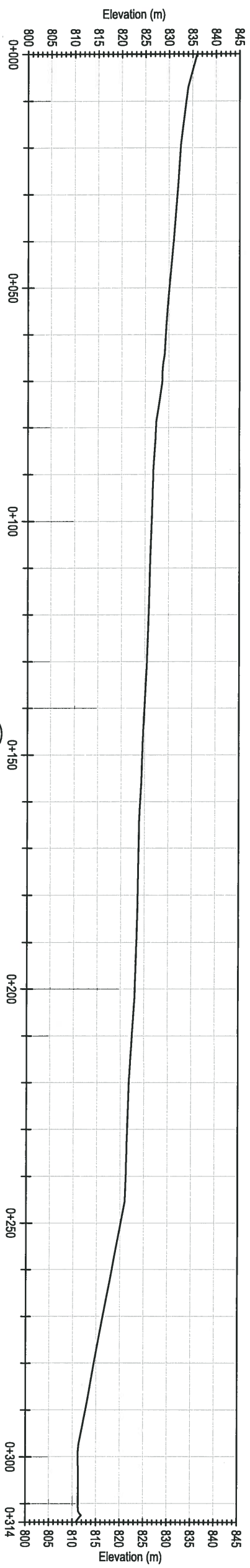

**LEGEND**

— As Built Profile

- - - Inferred Profile (See Note 2)



- NOTES**
1. As Built survey completed on April 14, 2019.
  2. Ditch profile is inferred due to ice presence at time of survey.

**RECORD DRAWING**

NUM	DATE	BY	CHK	APP	DESCRIPTION
0	5/17/19	JDM	MH	MH	RECORD DRAWING



**WATER MANAGEMENT PLAN**  
NELPECO EAGLE GOLD MINE, YT

**DITCH PROFILES**

PROJECT NO.	WTRM03037-01	OFFICE	VANC	DES	MH	CHK	MH	REV	0
DATE	May 17, 2019	SHEET No.	d	BY	JDM	APP	MH	STATUS	REC
									DRAWING
									<b>C1.02</b>

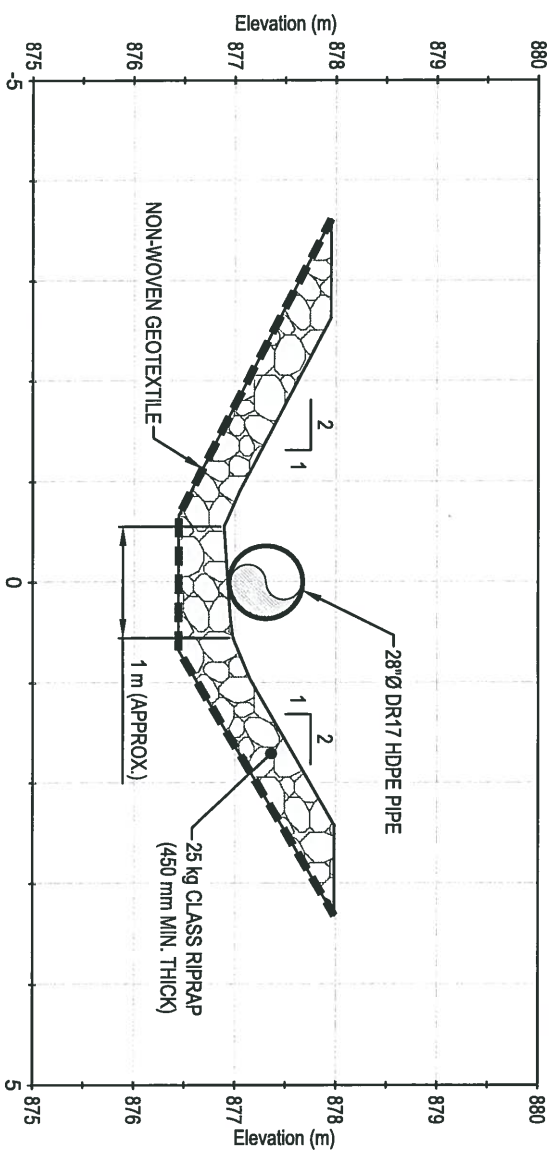

**A** TYPICAL DITCH SECTION  
C1.03 SCALE: 1:75

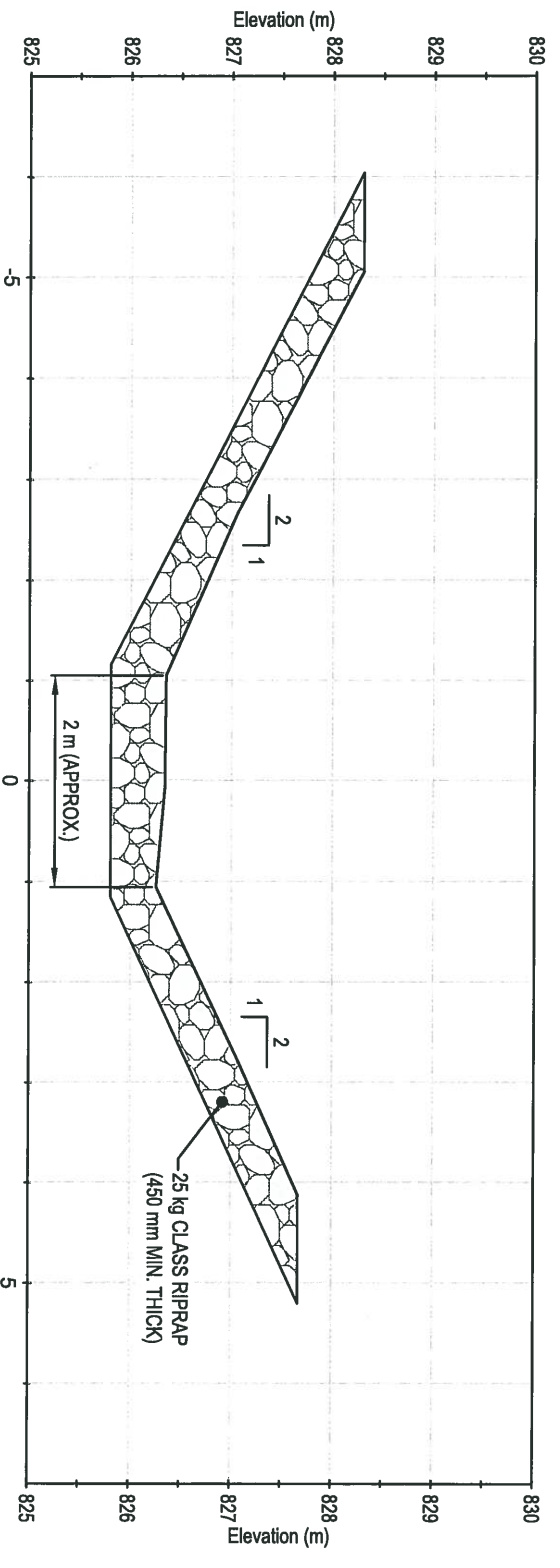

**B** TYPICAL DITCH SECTION  
C1.03 SCALE: 1:75

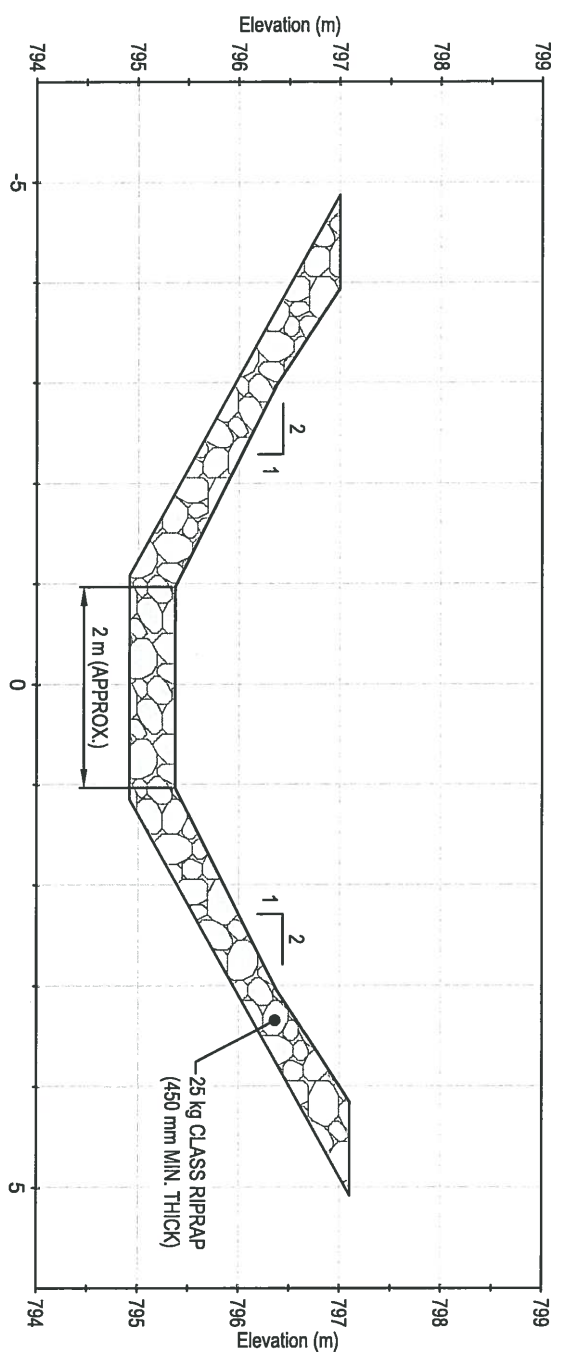

**C** TYPICAL DITCH SECTION  
C1.03 SCALE: 1:75



LEGEND NOTES

RECORD DRAWING

NUM	DATE	BY	CHK	APP	DESCRIPTION
0	5/17/19	JDM	MH	MH	RECORD DRAWING
REVISIONS					

PROFESSIONAL ENGINEER  
YUKON TERRITORY  
MAURICIO HERRERA  
5/17/19  
PROFESSIONAL SEAL

StrataGold Corporation

TETRA TECH

WATER MANAGEMENT PLAN  
NELPco EAGLE GOLD MINE, YT

DITCH CROSS SECTIONS

PROJECT NO.	OFFICE	DES	CHK	REV	DRAWING
WTRM03037-01	VANC	MH	MH	0	C1.03
DATE	SHEET No.	DWN	APP	STATUS	
May 17, 2019	of	JDM	MH	REC	

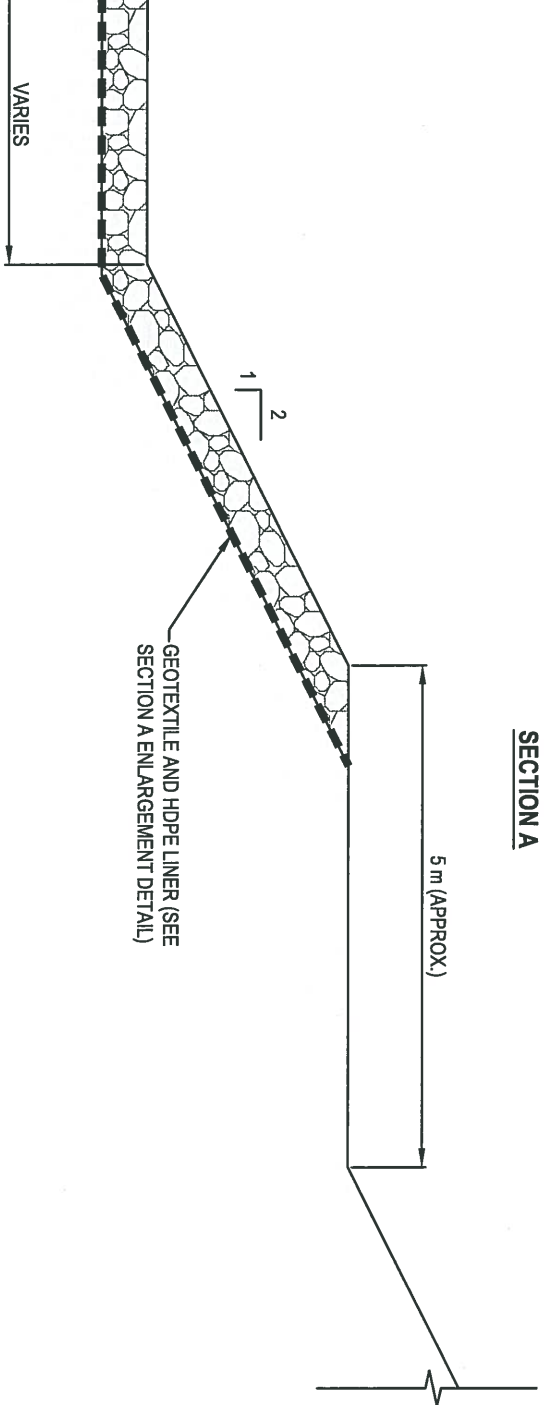
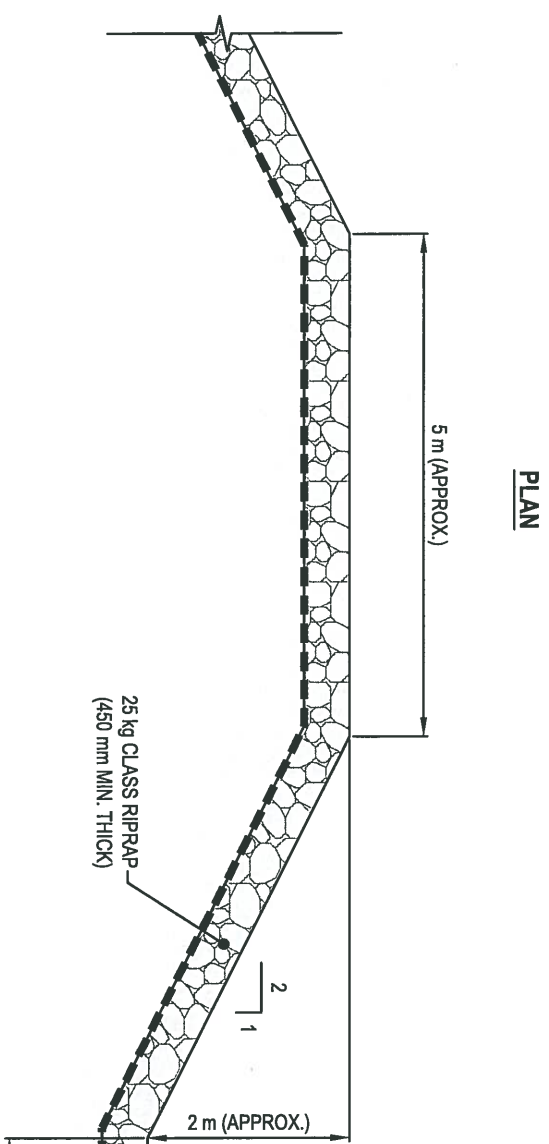
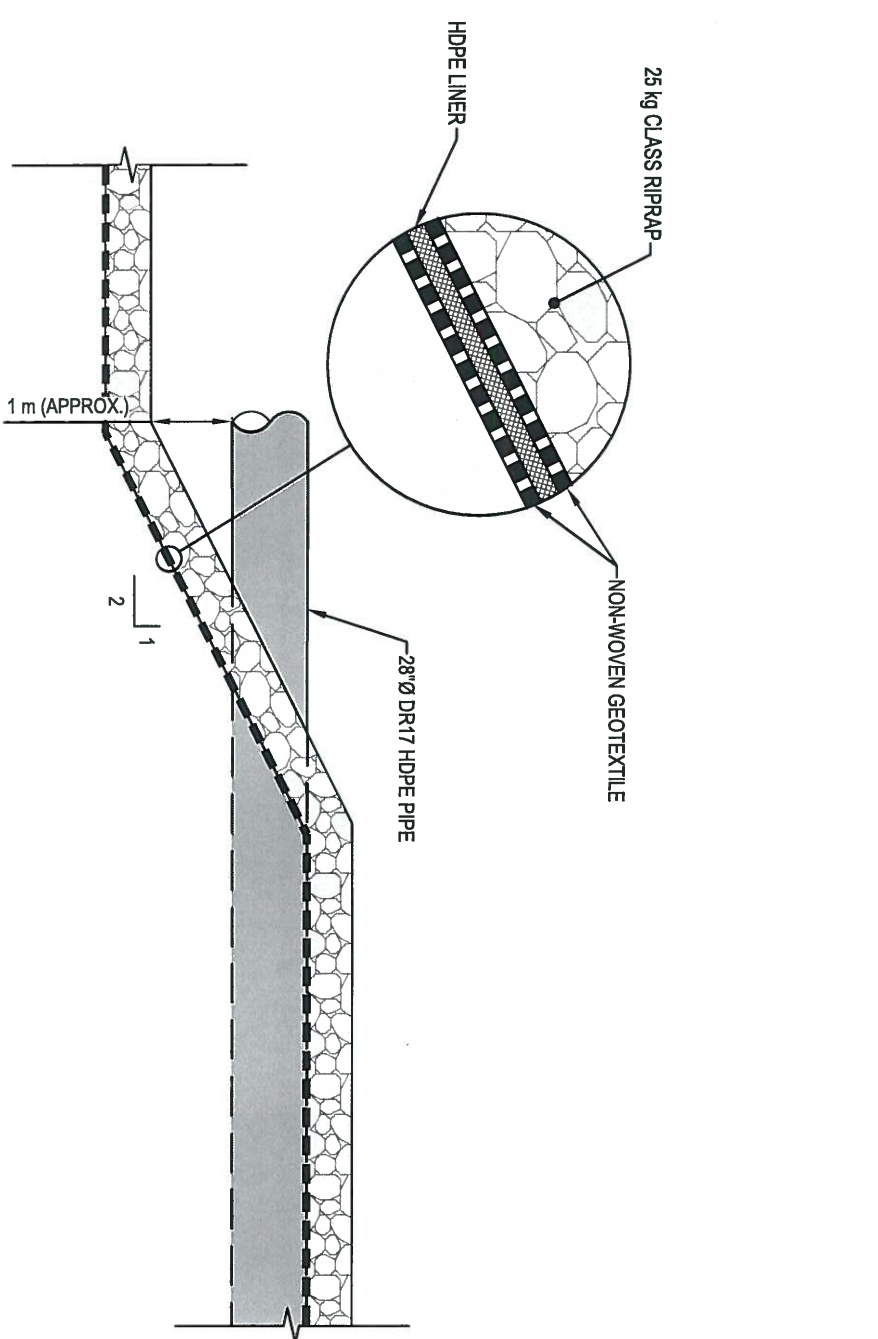
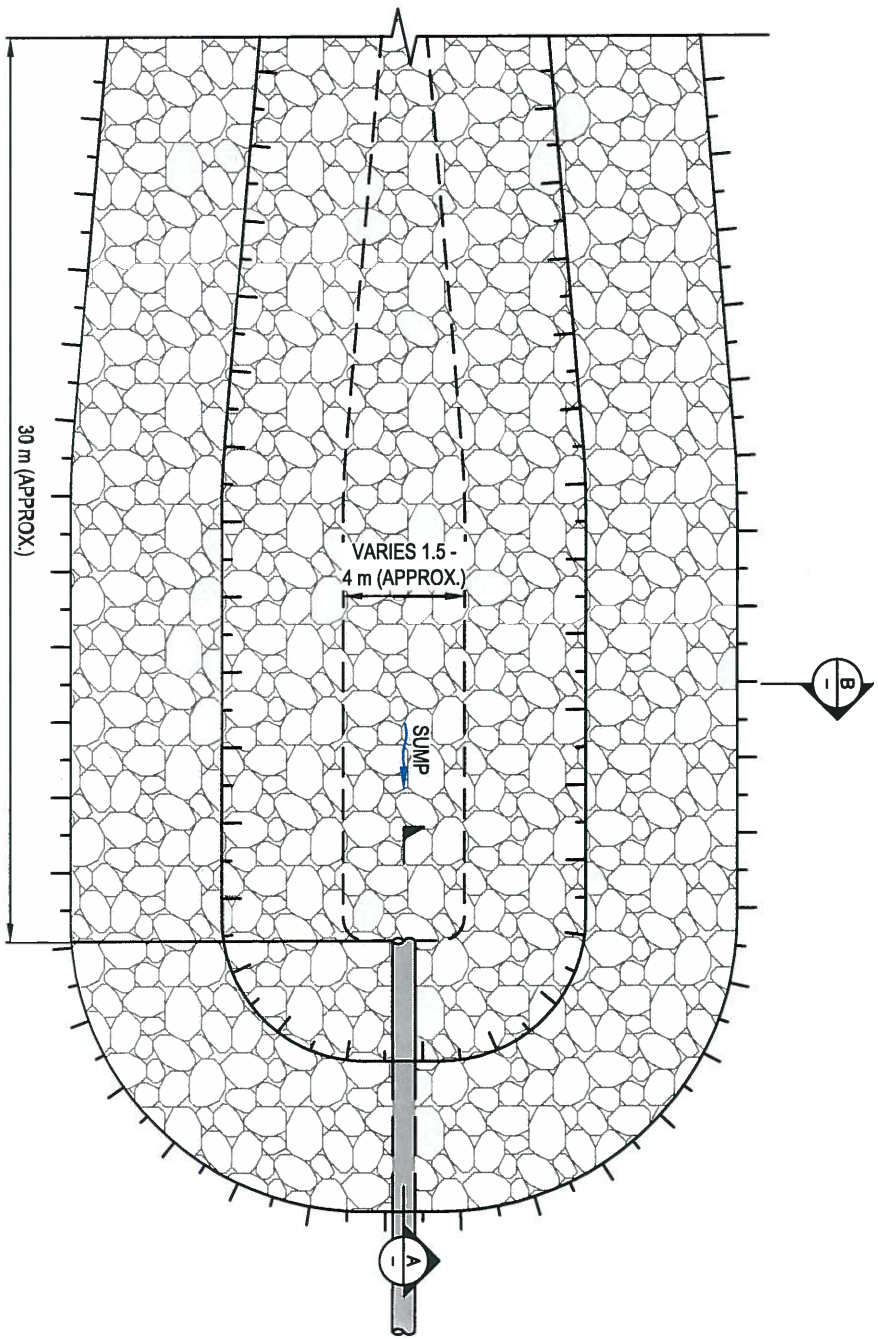

1 SUMP DETAIL  
C1.04 / SCALE: NTS

LEGEND NOTES

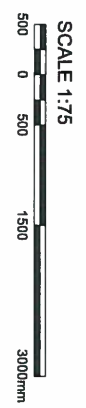

RECORD DRAWING

NUM	DATE	DMN	CHK	APP	REV	DESCRIPTION
0	5/17/19	JDM	MH	MH	0	RECORD DRAWING
REVISIONS						

PROFESSIONAL ENGINEER  
YUKON TERRITORY  
MAURICIO HERRERA  
5/17/19

StrataGold Corporation  
TETRA TECH

WATER MANAGEMENT PLAN  
NELPCO EAGLE GOLD MINE, YT

PROJECT NO.	OFFICE	DES	CHK	REV	DRAWING
WTRM03037-01	VANC	MH	MH	0	C1.04
DATE	SHEET No.	DMN	APP	STATUS	
May 17, 2019	of	JDM	MH	REC	

**APPENDIX C**  
**IFC Design Specifications, Drawing Package and**  
**Reissued Drawings**

# WATER MANAGEMENT PLAN

## NELPCo EAGLE GOLD MINE, YT



**SITE LOCATION**  
SCALE: NTS

**ISSUED FOR CONSTRUCTION**

\\local\hella\legacy\Drawing\Transportation\WTRM\WTRM03037-01 - Eagle Gold Design - R0.dwg [G1.00] July 14, 2017 - 11:46:26 am (BY: MANG, JUSTIN)

<b>CLIENT</b> 	<b>PROJECT NO.</b> WTRM03037-01	<b>OFFICE</b> VANC	<b>DES</b> DH	<b>CKD</b> MH	<b>REV</b> 1	<b>DRAWING</b> G1.00
		<b>DATE</b> July 14, 2017	<b>SHEET No.</b> of	<b>DWN</b> JDM	<b>APP</b> MH	



\\lcal\hella\Legacy\Vancover\Drafting\Transportation\WTRM\WTRM03037-01 - Eagle Gold Design - R0.dwg [G1.01] July 14, 2017 - 11:46:45 am (BY: MANG, JUSTIN)

INDEX OF DRAWINGS	
DWG No.	DESCRIPTION
G1.00	COVER SHEET
G1.01	DRAWING INDEX, GENERAL NOTES, SPECIFICATIONS AND QUANTITIES
G1.02	GEOTECHNICAL SPECIFICATIONS AND NOTES
G1.03	SEDIMENT AND EROSION CONTROL DETAILS
G1.04	BOREHOLE LOCATION PLAN
C1.00	GENERAL ARRANGEMENT - SITE PLAN
C1.01	LOWER DUBLIN SOUTH POND - PLAN
C1.02	LOWER DUBLIN SOUTH POND - PROFILES
C1.03	LOWER DUBLIN SOUTH POND - TYPICAL SECTIONS
C1.04	LOWER DUBLIN SOUTH POND - SPILLWAY PLAN AND PROFILE
C1.05	LOWER DUBLIN SOUTH POND - SECTIONS AND DETAILS
C1.06	LOWER DUBLIN SOUTH POND - LOW LEVEL OUTLET AND PUMPHOUSE
C1.07	CULVERT SECTIONS AND DETAILS
C1.08	DITCH DETAILS

**GENERAL NOTES:**

- THIS PROJECT SHALL BE CONSTRUCTED IN ACCORDANCE WITH THE CONTRACT PLANS AND SPECIFICATIONS AND ANY RULES, REGULATIONS, STANDARDS OR SPECIFICATIONS REFERENCED THEREIN.
- THE CONTRACTOR SHALL COMPLY WITH ALL LOCAL, TERRITORIAL AND FEDERAL LAWS THAT ARE PERTINENT TO THIS WORK.
- AVAILABLE DOCUMENTATION OF EXISTING OR RECENTLY CONSTRUCTED UTILITIES HAS BEEN INDICATED ON DRAWINGS. CONTRACTOR IS RESPONSIBLE FOR AVOIDING ALL UTILITIES WHETHER SHOWN ON THE DRAWINGS OR NOT.
- CONTRACTOR SHALL EXAMINE SITE FIRST HAND WITH OWNER'S REPRESENTATIVE TO DETERMINE THE NATURE AND TYPE OF MATERIALS TO BE CLEARED, EXCAVATED OR REMOVED PRIOR TO THE BIDDING OF WORK.

**DESIGN CRITERIA:**

- DAM CLASSIFICATION: SIGNIFICANT
- LOWER DUBLIN SOUTH POND CAPACITY (MINIMUM 24 HOUR RETENTION TIME): 1 IN 10 YEAR FLOOD.
- MAIN DAM SPILLWAY: 1 IN 1000 YEAR FLOOD
- COLLECTION DITCHES: 1 IN 10 YEAR FLOOD FOR CAPACITY, 1 IN 100 YEAR FLOOD FOR EROSION
- CULVERT DOWNSTREAM OF THE DAM (H w/D=1.5): 1 IN 1000 YEAR FLOOD
- REST OF CULVERTS (H w/D-1.5): 1 IN 200 YEAR FLOOD

**HYDROLOGY:**

- RECENT PRECIPITATION DATA HAS BEEN REVIEWED AS PART OF THE DESIGN AND FOUND TO BE WITHIN THE NATURAL VARIABILITY.

LEGEND NOTES

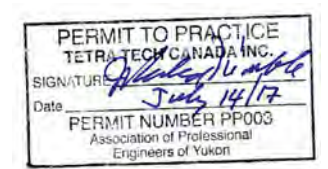

**ISSUED FOR CONSTRUCTION**

NUM	DATE	DWN	CKD	APR	DESCRIPTION
1	7/14/17	JDM	DH	MH	ISSUED FOR CONSTRUCTION
0	7/6/17	JDM	DH	MH	ISSUED FOR CONSTRUCTABILITY REVIEW

P.ENG. (B.C.)  
 July 14, 2017  
 Approved.



<b>WATER MANAGEMENT PLAN          NELPCo EAGLE GOLD MINE , YT</b>					
<b>DRAWING INDEX, GENERAL NOTES          SPECIFICATIONS AND QUANTITIES</b>					
PROJECT NO. WTRM03037-01	OFFICE VANC	DES DH	CKD MH	REV 1	DRAWING G1.01
DATE July 14, 2017	SHEET No. of	DWN JDM	APP MH	STATUS IFC	

**GEOTECHNICAL INVESTIGATION:**

1. A GEOTECHNICAL INVESTIGATION WAS CONDUCTED FROM JUNE 10-13, 2017. APPENDIX A INCLUDES LAB RESULTS FROM THE INVESTIGATION.

**GEOTECHNICAL NOTES:**

• **PREPARATION**

1. REMOVE DEBRIS, SNOW, ICE, WATER, AND LOOSE MATERIAL PRIOR TO STARTING FILL PLACEMENT.
2. DO NOT PLACE FILL MATERIAL WHEN THE MATERIAL, THE FOUNDATION, OR THE RECEIVING SURFACE IS FROZEN.
3. DO NOT PLACE FILL MATERIAL ON ANY SURFACE UNTIL THE PREPARED SURFACE HAS BEEN INSPECTED BY THE OWNER'S REPRESENTATIVE AND ANY DEFECTS IDENTIFIED BY THE OWNER'S REPRESENTATIVE HAVE BEEN RECTIFIED.
4. PROTECT SURFACES PREPARED TO RECEIVE FILL FROM FREEZING.
5. BOND PRIOR TO PLACING THE FIRST LIFT OF FILL. SCARIFICATION OF BEDROCK AND RIPRAP SURFACES IS NOT REQUIRED.
6. GRADE AND COMPACT THE SCARIFIED FOUNDATION SURFACE TO THE SAME DENSITY.
7. CAREFULLY INSPECT ALL EXCAVATIONS BEFORE DOING ANY WORK IN THE EXCAVATIONS. LOOK FOR SIGNS OF CRACKS ABOVE SLOPES, SEEPAGE, AND ANY OTHER SIGNS OF SLOPE INSTABILITY OR POTENTIAL FOR LOOSE MATERIAL TO BECOME DISLODGED.
8. MAINTAIN SIDES AND SLOPES OF EXCAVATIONS IN SAFE CONDITION BY APPROPRIATE METHODS AND IN ACCORDANCE WITH THE ACT FOR THE PROVINCE OF ALBERTA.
9. REMOVE SOIL BLOCKS, BOULDERS, LOOSE ROCK AND OTHER FRAGMENTS THAT MAY SLIDE OR ROLL INTO THE EXCAVATED AREAS AND ANY ACCUMULATIONS OF SUCH MATERIALS FROM THE BASE OF EXCAVATIONS.
10. WHERE CONDITIONS ARE UNSTABLE, CONTRACTOR'S ENGINEER TO DEVELOP A PLAN TO ALLOW SAFE ACCESS.
11. EXCAVATE TO LINES, GRADES, ELEVATIONS AND DIMENSIONS AS INDICATED ON CONSTRUCTION DRAWINGS.

• **DEWATERING AND HEAVE PREVENTION**

1. KEEP EXCAVATIONS FREE OF WATER WHILE WORK IS IN PROGRESS.
2. THE DEWATERED CONSTRUCTION AREA SHOULD BE SUFFICIENT TO ALLOW FULL RECONSTRUCTION OF THE EMBANKMENT AS SHOWN IN THE CONSTRUCTION DRAWINGS.
3. AVOID EXCAVATION BELOW GROUNDWATER TABLE IF QUICK CONDITION OR HEAVE IS LIKELY TO OCCUR.
  - a. PREVENT PIPING OR BOTTOM HEAVE OF EXCAVATIONS BY GROUNDWATER LOWERING, SHEET PILE CUT-OFFS, OR OTHER MEANS.
4. PROTECT OPEN EXCAVATIONS AGAINST FLOODING AND DAMAGE DUE TO SURFACE RUN-OFF.

• **FILL TYPES AND COMPACTION**

1. DO NOT PLACE ORGANIC MATERIALS IN THE FILL.
2. COORDINATE EXCAVATION AND FILL PLACEMENT OPERATIONS, WHERE PRACTICAL, TO ESTABLISH EFFICIENT CONSTRUCTION EFFORT AND MAKE EFFICIENT USE OF EXCAVATED MATERIALS.
3. PLACE FILL AT THE LOCATIONS, AND TO THE LINES, GRADES, AND ELEVATIONS SHOWN ON THE CONSTRUCTION DRAWINGS OR AS ESTABLISHED BY THE OWNER'S REPRESENTATIVE, USING SPECIFIED FILL MATERIALS PLACED, CONDITIONED AND COMPACTED TO THE SPECIFIED REQUIREMENTS.
4. OVERBUILD FINAL FILL SLOPES AND THEN TRIM THEM TO THE LINES, GRADES, AND ELEVATIONS SHOWN ON THE CONSTRUCTION DRAWINGS, OR AS ESTABLISHED BY THE OWNER'S REPRESENTATIVE.
5. MAINTAIN THE TOP SURFACE OF FILL ZONES APPROXIMATELY HORIZONTAL. DURING SPREADING AND COMPACTION, PROVIDE THE SURFACE OF THE FILL ZONE WITH A GENTLE TRANSVERSE GRADIENT OF 3% TO 5% SO THAT WATER FROM PRECIPITATION WILL DRAIN FREELY TOWARD THE EXTREMITIES OF THE FILL ZONE, BUT AWAY FROM ANY FILTER MATERIALS. IMMEDIATELY PRIOR TO ANY SUSPENSION IN FILL OPERATIONS, SLOPE THE FILL SURFACE AT THE ABOVE GRADIENT AND ROLL WITH A SMOOTH CYLINDRICAL ROLLER SO AS TO LEAVE THE SURFACE AREA IN A SMOOTH, EVEN CONDITION FOR DRAINAGE.
6. PLACE AND SPREAD FILL MATERIALS IN CONTINUOUS AND APPROXIMATELY HORIZONTAL LAYERS OF UNIFORM THICKNESS AS PER SECTION 3.10 - COMPACTION IN SUCH A MANNER AS TO PREVENT SEGREGATION AND STRATIFICATION AND TO OBTAIN A HOMOGENEOUS MASS.

7. PLACE AND SPREAD EMBANKMENT DAM MATERIALS IN A DIRECTION PARALLEL TO THE DAM AXIS TO MINIMIZE THE POTENTIAL FORMATION OF PREFERENTIAL SEEPAGE PATHS.
8. USE DISCS AS NECESSARY DURING FILL PLACEMENT TO MIX OR BLEND AS REQUIRED, TO OBTAIN A CONSISTENT FILL MATERIAL, AND TO SCARIFY, BLEND, AND BREAK UP MATERIALS TO THE FULL DEPTH OF THE UNCOMPACTED LIFT.
9. COMMENCE PLACEMENT OF FILL MATERIALS AT THE LOWEST ELEVATION OF THE FOUNDATION OR EXCAVATION AND PROGRESS IN AN UPSLOPE DIRECTION.
10. MOISTEN EACH PREVIOUSLY PLACED LIFT, IF NECESSARY, AND WORK WITH DISCS TO A MINIMUM DEPTH OF 50 mm TO PROVIDE A BONDING SURFACE, PRIOR TO PLACING THE OVERLYING LIFT OF FILL MATERIAL EXCEPT WHEN, IN THE OPINION OF THE OWNER'S REPRESENTATIVE, SUCH WORK CANNOT BE PERFORMED BECAUSE OF COLD WEATHER.
11. JOIN NEW FILL ONTO ALL NATURAL, EXCAVATED, OR FILL SLOPES BY TERRACING OR STEPPING INTO THE SLOPES A MINIMUM OF 1.5 m WIDE. STAGGER FILL JOINTS TO MINIMIZE THE POTENTIAL FOR PREFERRED SEEPAGE PATHS IN ANY DIRECTION.

• **MOISTURE CONTROL**

1. MOISTURE CONTENT, EXCEPT FOR RIPRAP MATERIALS, SHALL BE WITHIN  $\pm 0.5\%$  OF THE OPTIMUM MOISTURE CONTENT DETERMINED IN ACCORDANCE WITH ASTM D698.
2. THE MOISTURE CONTENT OF FILL MATERIALS SHALL BE DETERMINED IN ACCORDANCE WITH ASTM D2216.
3. ADD WATER TO THE FILL MATERIAL WHEN ITS MOISTURE CONTENT IS BELOW THAT SPECIFIED. USE METHODS THAT PERMIT WATER TO BE ADDED, IN CONTROLLED AMOUNTS, AND WHICH DO NOT CAUSE FINER MATERIALS TO BE WASHED OUT. WORK THE WATER INTO THE FILL MATERIAL UNTIL THE SPECIFIED MOISTURE CONTENT IS UNIFORMLY OBTAINED THROUGHOUT THE MATERIAL.
4. WHEN THE MOISTURE CONTENT OF THE FILL MATERIAL EXCEEDS THE SPECIFIED LIMITS, DRY THE FILL MATERIAL, PRIOR TO COMPACTION, BY SPREADING, DISCING, AND HARROWING THE FILL MATERIAL UNTIL THE SPECIFIED MOISTURE CONTENT IS UNIFORMLY OBTAINED THROUGHOUT THE MATERIAL.

• **COMPACTION**

LIFT THICKNESS, COMPACTION REQUIREMENTS, AND DENSITIES SHALL CONFORM TO THE FOLLOWING UNLESS SPECIFIED OTHERWISE:

EMBANKMENT FILL	200 mm LOOSE LIFT THICKNESS	$\geq 98\%$ SPMDD
-----------------	-----------------------------	-------------------

1. COMPACTED DENSITY LIMITS, IN CLAUSE 3.9.1, SHALL BE TO STANDARD PROCTOR MAXIMUM DRY DENSITY (SPMDD) AS DETERMINED BY ASTM D698, OR MAXIMUM VIBRATED DENSITY (MVD) AS DETERMINED BY ASTM D4253.
2. USE COMPACTION EQUIPMENT OF THE TYPE, SIZE, AND EFFICIENCY CAPABLE OF ACHIEVING THE SPECIFIED DENSITIES AND COMMENSURATE WITH THE NATURE OF THE FILL PLACEMENT OPERATION.
3. UNLESS OTHERWISE AUTHORIZED BY THE OWNER'S REPRESENTATIVE, USE A SUITABLY-SIZED VIBRATORY SMOOTH-DRUM ROLLERS FOR GRANULAR MATERIALS.
4. IN AREAS THAT ARE NOT ACCESSIBLE TO LARGER COMPACTION EQUIPMENT, OR WHICH ARE WITHIN 1000 mm OF STRUCTURES OR 600 mm FROM PIPES, OR OTHER ITEMS SUSCEPTIBLE TO COMPACTION INDUCED DAMAGE, REDUCE THE LIFT THICKNESS AND COMPACT FILL MATERIALS WITH HAND OPERATED PNEUMATIC OR MECHANICAL TAMPING EQUIPMENT.
5. APPLY COMPACTION EFFORT FOR A MINIMUM HORIZONTAL DISTANCE OF 600 mm BEYOND THE EDGE OF THE FILL ZONES.
6. COMPACTION REQUIREMENTS FOR MATERIAL THAT CANNOT PRACTICALLY BE TESTED AND COMPARED TO STANDARD PROCTOR DENSITIES, COMPACTION EFFORT SHOULD BE APPROVED BY THE OWNER'S REPRESENTATIVE.
7. EMBANKMENT CREST SHALL BE + 100 mm / 0 mm.

\\local\heta\legacy\Vancover\Drafting\Transportation\WTRM\WTRM03037-01 - Eagle Gold Design - R0.dwg [G1.02] July 14, 2017 - 11:47:19 am (BY: MANG, JUSTIN)

LEGEND

NOTES

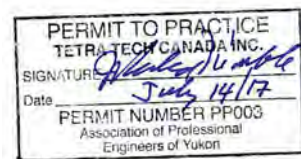

**ISSUED FOR CONSTRUCTION**

NUM	DATE	DWN	CKD	APR	DESCRIPTION
1	7/14/17	JDM	DH	MH	ISSUED FOR CONSTRUCTION
0	7/6/17	JDM	DH	MH	ISSUED FOR CONSTRUCTION REVIEW

PROFESSIONAL SEAL

CLIENT

**WATER MANAGEMENT PLAN  
NELPCo EAGLE GOLD MINE, YT**

**GEOTECHNICAL SPECIFICATIONS AND NOTES**

PROJECT NO. WTRM03037-01	OFFICE VANC	DES JS	CKD MH	REV 1	DRAWING G1.02
DATE July 14, 2017	SHEET No. of	DWN JDM	APP MH	STATUS IFC	

\\lcal\heta\legacy\Vancover\Drafting\Transportation\WTRM03037-01 - Eagle Gold Details - RD.dwg [G1.03] July 14, 2017 - 12:25:39 pm (BY: MANG, JUSTIN)

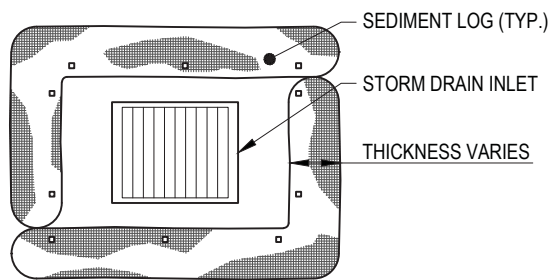
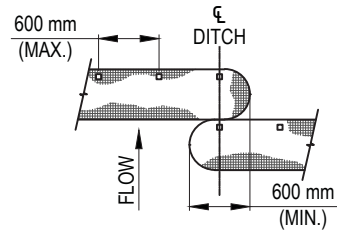

**INLET PROTECTION**

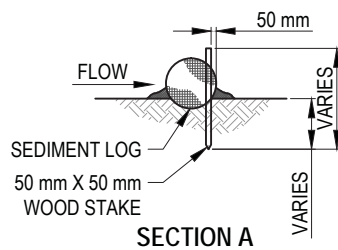
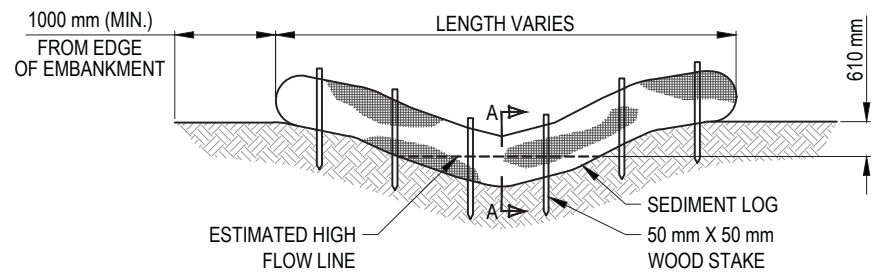

**1 SEDIMENT LOGS**  
G1.03 SCALE: NTS

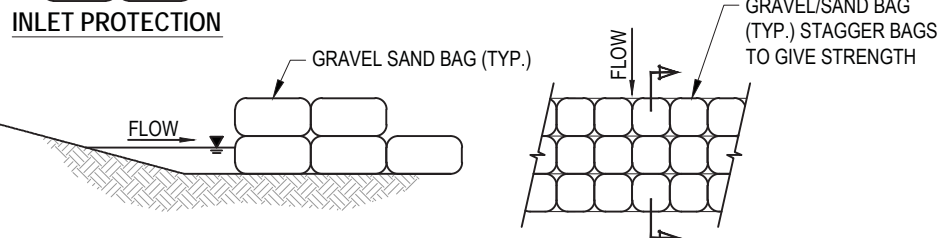
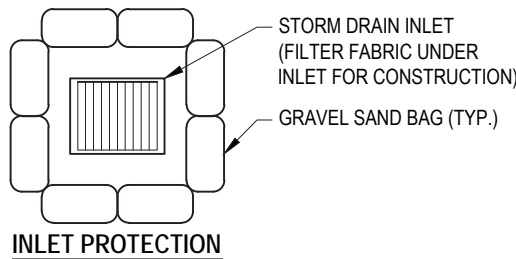

**SECTION**

**PLAN**

**2 GRAVEL/SAND BAG BARRIER DETAIL**  
G1.03 SCALE: NTS



**ISSUED FOR CONSTRUCTION**

NUM	DATE	DWN	CKD	APR	DESCRIPTION
1	7/14/17	JDM	DH	MH	ISSUED FOR CONSTRUCTION
0	7/6/17	JDM	DH	MH	ISSUED FOR CONSTRUCTABILITY REVIEW

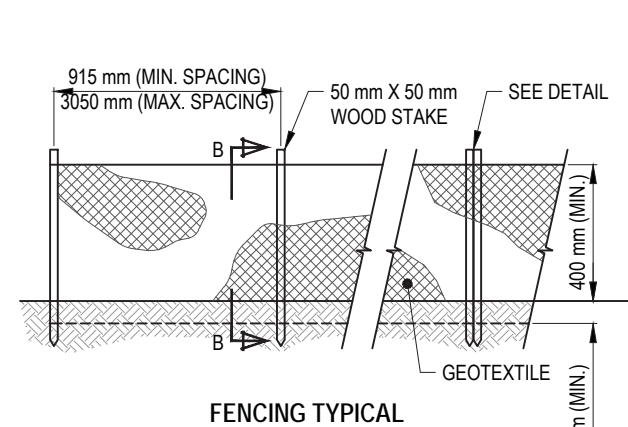

**FENCING TYPICAL**

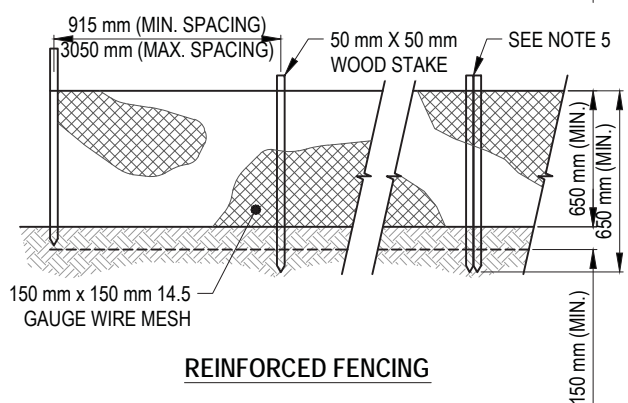

**REINFORCED FENCING**

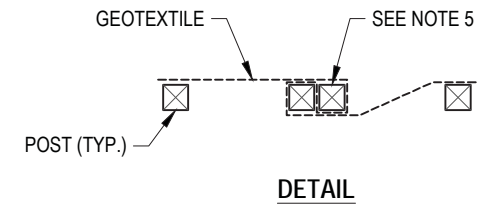

**DETAIL**

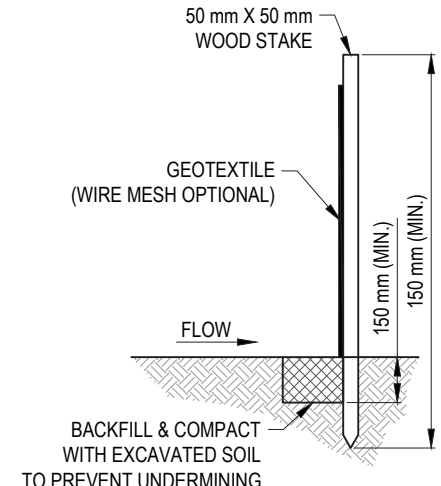

**SECTION B**

**3 SILT FENCE**  
G1.03 SCALE: NTS

**GENERAL NOTES:**

- SILT FENCE SHALL BE CONSTRUCTED BEFORE UPSLOPE LAND DISTURBANCES BEGIN.
- PLACE SILT FENCE AS CLOSE TO CONTOUR AS POSSIBLE SO THAT WATER WILL NOT CONCENTRATE AT LOW POINTS AND SO THAT SMALL SWALES OR DEPRESSIONS WHICH MAY CARRY SMALL CONCENTRATED FLOWS TO SILT FENCE ARE DISSIPATED ALONG ITS LENGTH.
- WHERE POSSIBLE, SILT FENCE SHALL BE PLACED ON FLATTEST AREA AVAILABLE.
- SILT FENCE SHOULD BE CONSTRUCTED IN A HORSESHOE SHAPE WITH ENDS POINTING UPSLOPE TO MAXIMIZE BOTH STRENGTH AND EFFECTIVENESS.
- SEAMS BETWEEN SECTIONS SHALL BE OVERLAPPED WITH THE END STAKES OF EACH SECTION WRAPPED TOGETHER BEFORE DRIVING INTO THE GROUND.
- SILT FENCE SHALL BE BURIED IN THE GROUND AT A MINIMUM OF 150 mm TO PREVENT ANY UNDERCUTTING OR EROSION.
- ADDITIONAL POST DEPTH OR WIRE MESH BACKING MAY BE REQUIRED IN UNSTABLE SOILS.

LEGEND NOTES

CLIENT  
**StrataGold Corporation**

**WATER MANAGEMENT PLAN  
NELPCo EAGLE GOLD MINE, YT**

**SEDIMENT AND EROSION CONTROL DETAILS**

PROJECT NO. WTRM03037-01	OFFICE VANC	DES DH	CKD MH	REV 1	DRAWING G1.03
DATE July 14, 2017	SHEET No. of	DWN JDM	APP MH	STATUS IFC	

**TETRA TECH EBA**

PROFESSIONAL SEAL  
[Signature]  
P. ENG. (B.C.)  
July 14, 2017

\\local\heta\legacy\Drawing\Transportation\WTRM\WTRM03037-01 - Eagle Gold Design\_R0.dwg [G1.04] July 14, 2017 - 11:47:36 am (BY: MANG, JUSTIN)

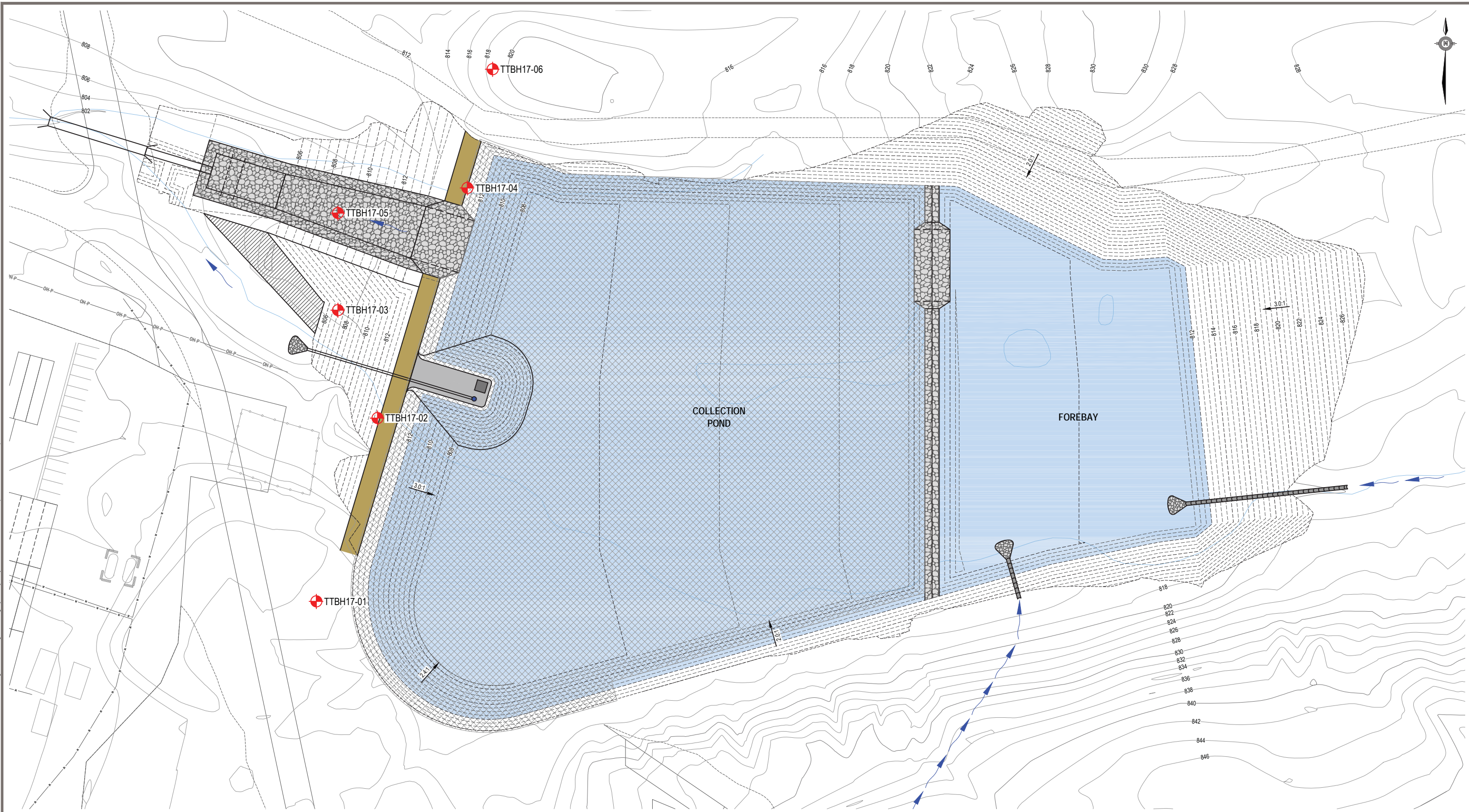

- LEGEND**
- Design Major Contours (2 m)
  - Design Minor Contours (0.5 m)

**NOTES**

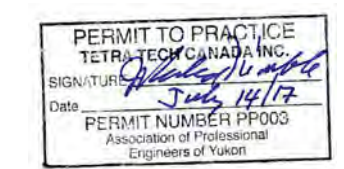

**ISSUED FOR CONSTRUCTION**

NUM	DATE	DWN	CKD	APR	DESCRIPTION
0	7/14/17	JDM	DH	MH	ISSUED FOR CONSTRUCTION
REVISIONS					

July 14, 2017  
 PROFESSIONAL SEAL

CLIENT

<b>WATER MANAGEMENT PLAN NELPCo EAGLE GOLD MINE, YT</b>					
<b>BOREHOLE LOCATION PLAN</b>					
PROJECT NO. WTRM03037-01	OFFICE VANC	DES DH	CKD MH	REV 0	DRAWING G1.04
DATE July 14, 2017	SHEET No. of	DWN JDM	APP MH	STATUS IFC	

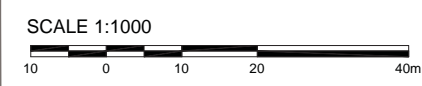

I:\local\beta\Legacy\Vancover\Drafting\Transportation\WTRM03037-01 - Eagle Gold Design - RD.dwg [C1.00] July 14, 2017 - 11:45:02 am (BY: MANG, JUSTIN)

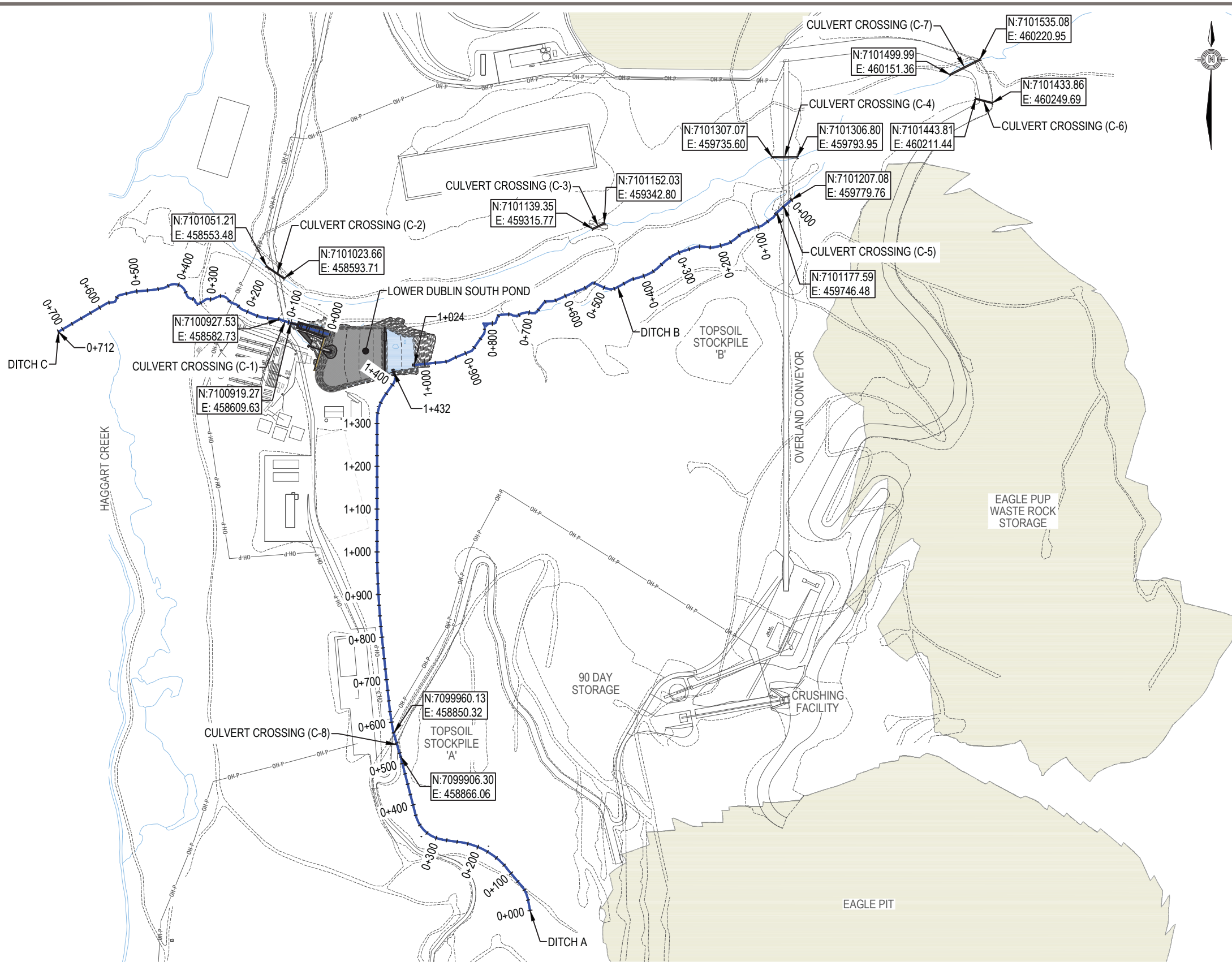

DITCH A		
STATION (m)	LENGTH (m)	TYPE
0+000 - 0+355	355	TYPE 3A
0+355 - 0+519	164	TYPE 2
0+519 - 0+575	CULVERT C-8 (SEE CULVERT TABLE)	
0+575 - 0+845	270	TYPE 3A
0+845 - 1+020	175	TYPE 2
1+020 - 1+330	310	TYPE 3B
1+330 - 1+420	90	TYPE 3E

DITCH B		
STATION (m)	LENGTH (m)	TYPE
0+000 - 0+045	CULVERT C-5 (SEE CULVERT TABLE)	
0+045 - 0+050	5	GABION STEPPED
0+050 - 0+560	510	TYPE 3D
0+560 - 0+886	326	TYPE 3B
0+886 - 0+980	94	TYPE 3D

DITCH C		
STATION (m)	LENGTH (m)	TYPE
0+000 - 0+075	SPILLWAY	
0+075 - 0+095	20	TYPE 3A
0+095 - 0+123	CULVERT C-1 (SEE CULVERT TABLE)	
0+123 - 0+320	197	TYPE 3B
0+320 - 0+440	120	TYPE 3E
0+440 - 0+712	272	TYPE 3B

**NOTES:**

1. STATIONING AND LENGTHS ARE APPROXIMATE.
2. FOR DITCH TYPES SEE DETAIL 1/C1.08.
3. PROPOSED RIPRAP REVETMENT AS SHOWN ON DETAIL 1/C1.08 (DITCH TYPE 3) SHALL BE FIELD FITTED AND ADJUSTED TO SITE CONDITIONS.

CULVERT TABLE			
CULVERT ID	LENGTH (m)	DIAMETER (mm)	BARRELS
C-1	28	2200	2
C-2	49	1200	2
C-3	30	900	1
C-4	58	1200	2
C-5	44	800	1
C-6	40	750	1
C-7	78	900	2
C-8	56	1200	2

**NOTES:**

1. CULVERT LENGTHS, NORTHINGS AND EASTINGS ARE APPROXIMATE.
2. SEE DETAIL 2/C1.07 FOR TYPICAL CULVERT CROSSING.
3. ALL CSP CULVERTS SHALL BE 14 GAUGE (THICKNESS 0.079") ALUMINIZED STEEL TYPE 2 (ALT2) WITH A MINIMUM OF 1 m COVER.
4. GRAVEL LINE BOTTOM OF CULVERT C-3 FOR FISH PASSAGE.

**LEGEND** **NOTES**

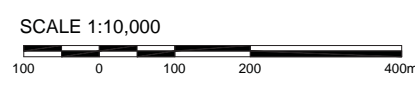

PERMIT TO PRACTICE  
TETRA TECH CANADA INC.  
SIGNATURE: *[Signature]*  
Date: July 14/17  
PERMIT NUMBER PPO03  
Association of Professional Engineers of Yukon

**ISSUED FOR CONSTRUCTION**

NUM	DATE	DWN	CKD	APR	DESCRIPTION
1	7/14/17	JDM	DH	MH	ISSUED FOR CONSTRUCTION
0	7/6/17	JDM	DH	MH	ISSUED FOR CONSTRUCTABILITY REVIEW

*[Signature]* P.ENG. (B.C.)  
July 14, 2017  
APPROVED

CLIENT

WATER MANAGEMENT PLAN NELPCo EAGLE GOLD MINE, YT					
GENERAL ARRANGEMENT SITE PLAN					
PROJECT NO. WTRM03037-01	OFFICE VANC	DES DH	CKD MH	REV 1	DRAWING C1.00
DATE July 14, 2017	SHEET No. of	DWN JDM	APP MH	STATUS IFC	

\\lcal\heta\legacy\Vancover\Drafting\Transportation\WTRM03037-01 - Eagle Gold Design - RD.dwg [C1.01] July 14, 2017 - 12:20:58 pm (BY: MANG, JUSTIN)

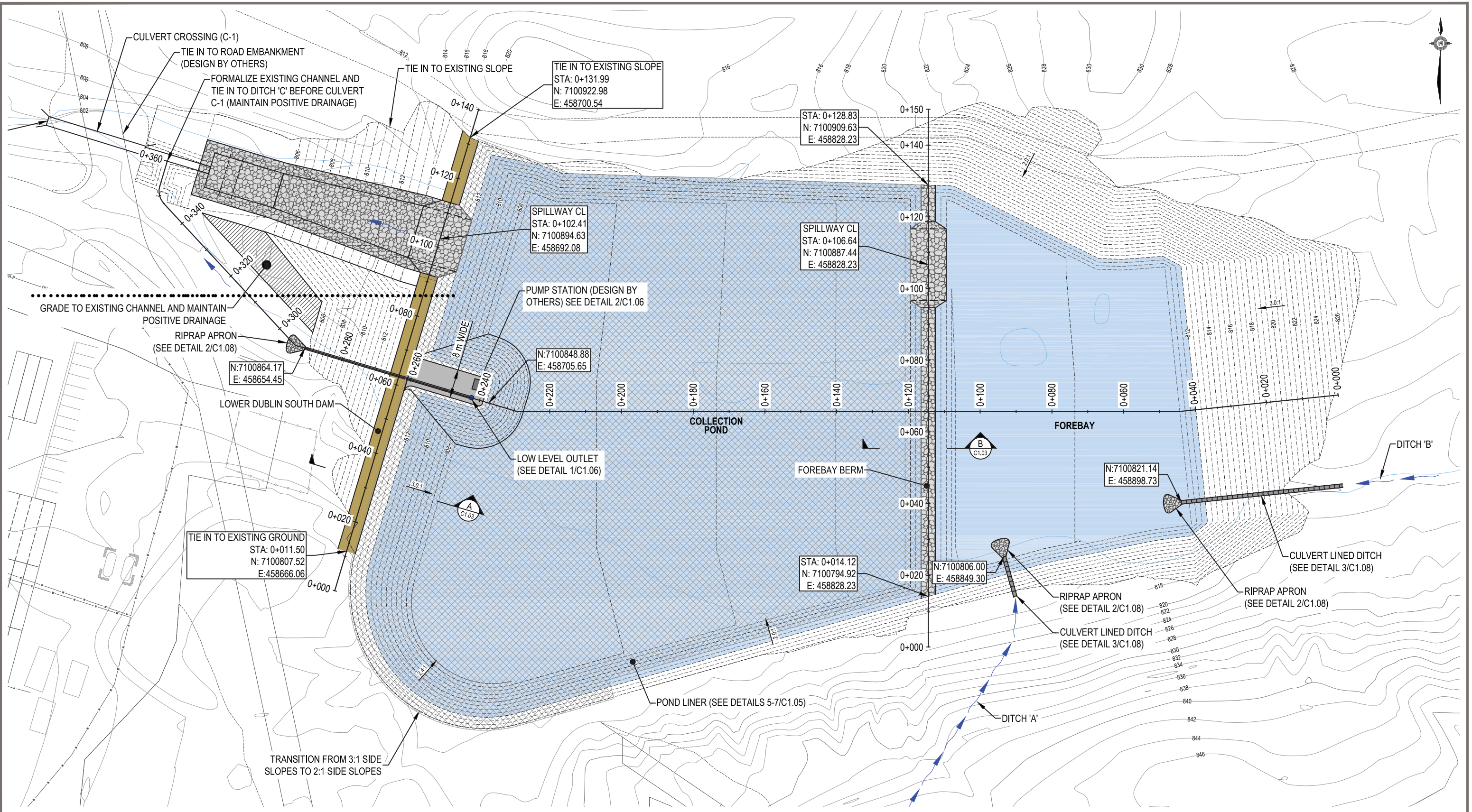

**LEGEND**

- Design Major Contours (2 m)
- - - Design Minor Contours (0.5 m)

**NOTES**

SCALE 1:1000

10 0 10 20 40m

**PERMIT TO PRACTICE**  
 TETRA TECH CANADA INC.  
 SIGNATURE: *[Signature]*  
 Date: July 14/17  
 PERMIT NUMBER PPO03  
 Association of Professional Engineers of Yukon

**ISSUED FOR CONSTRUCTION**

NUM	DATE	DWN	CKD	APR	REVISIONS	DESCRIPTION
1	7/14/17	JDM	DH	MH	ISSUED FOR CONSTRUCTION	
0	7/6/17	JDM	DH	MH	ISSUED FOR CONSTRUCTABILITY REVIEW	

*[Signature]* P.ENG (B.C.)  
 July 14/2017  
 Approved

*[Signature]*  
 July 14, 2017

PROFESSIONAL SEAL

CLIENT

**StrataGold Corporation**

**TETRA TECH EBA**

**WATER MANAGEMENT PLAN**  
 NELPCo EAGLE GOLD MINE, YT

**LOWER DUBLIN SOUTH POND PLAN**

PROJECT NO. WTRM03037-01	OFFICE VANC	DES DH	CKD MH	REV 1	DRAWING C1.01
DATE July 14, 2017	SHEET No. of	DWN JDM	APP MH	STATUS IFC	

I:\local\legacy\Vancover\Drafting\Transportation\WTRM\WTRM03037-01 - Eagle Gold Design - R0.dwg [C1.02] July 14, 2017 - 12:23:04 pm (BY: MANG, JUSTIN)

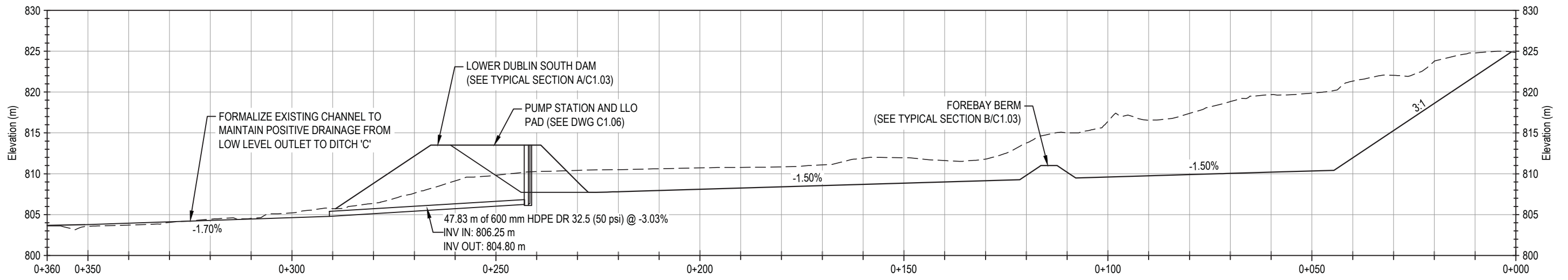

**1 POND CENTERLINE PROFILE**  
C1.02 SCALE: 1:1000 (HORIZ.) 1:500 (VERT)

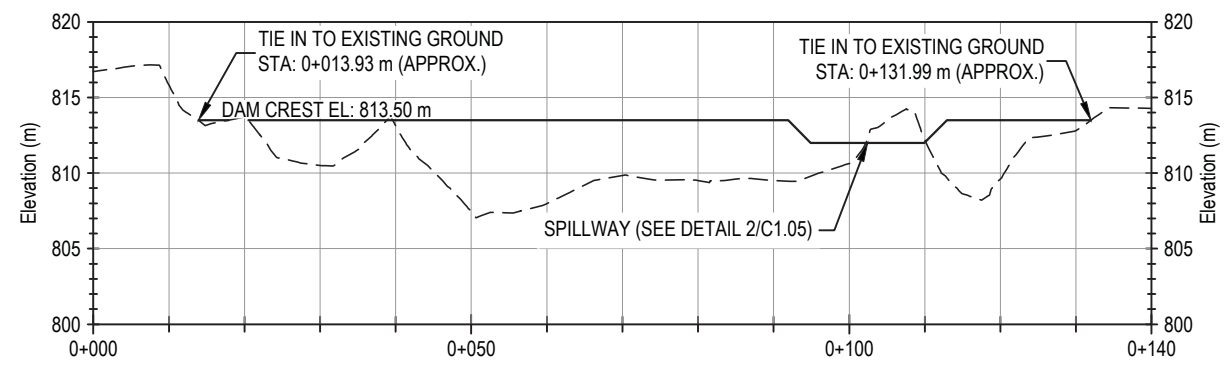

**2 DAM CENTERLINE PROFILE**  
C1.02 SCALE: 1:1000 (HORIZ.) 1:500 (VERT)

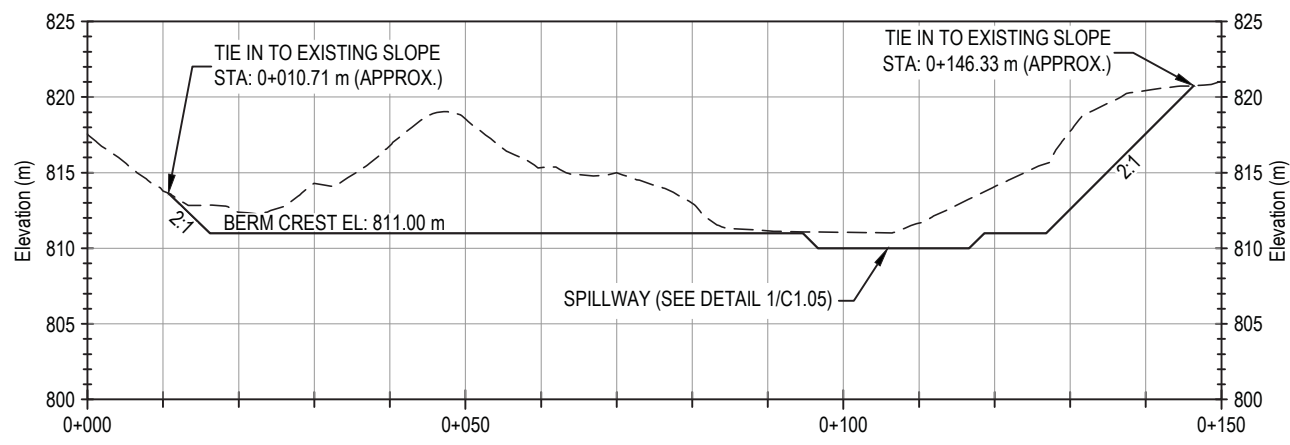

**3 BERM CENTERLINE PROFILE**  
C1.02 SCALE: 1:1000 (HORIZ.) 1:500 (VERT)

**NOTE:**

- 1. PROFILE VIEWS ARE EXAGGERATED BY TWO TIMES VERTICALLY.

**LEGEND**  
 - - - - Existing Ground  
 ——— Proposed Ground

**NOTES**

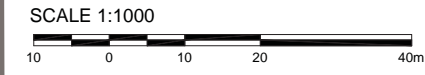

**ISSUED FOR CONSTRUCTION**

NUM	DATE	DWN	CKD	APR	DESCRIPTION
1	7/14/17	JDM	DH	MH	ISSUED FOR CONSTRUCTION
0	7/6/17	JDM	DH	MH	ISSUED FOR CONSTRUCTABILITY REVIEW

*[Handwritten Signature]* P.ENG. (B.C.)  
July 14/2017  
It approved.

*[Handwritten Signature]*  
July 14, 2017



<b>WATER MANAGEMENT PLAN NELPCo EAGLE GOLD MINE, YT</b>					
<b>LOWER DUBLIN SOUTH POND PROFILES</b>					
PROJECT NO. WTRM03037-01	OFFICE VANC	DES DH	CKD MH	REV 1	DRAWING C1.02
DATE July 14, 2017	SHEET No. of	DWN JDM	APP MH	STATUS IFC	

\\l:\local\heta\Legacy\Vancover\Drafting\Transportation\WTRM\WTRM03037-01 - Eagle Gold Design - R0.dwg [C1.03] July 14, 2017 - 12:23:25 pm (BY: MANG, JUSTIN)

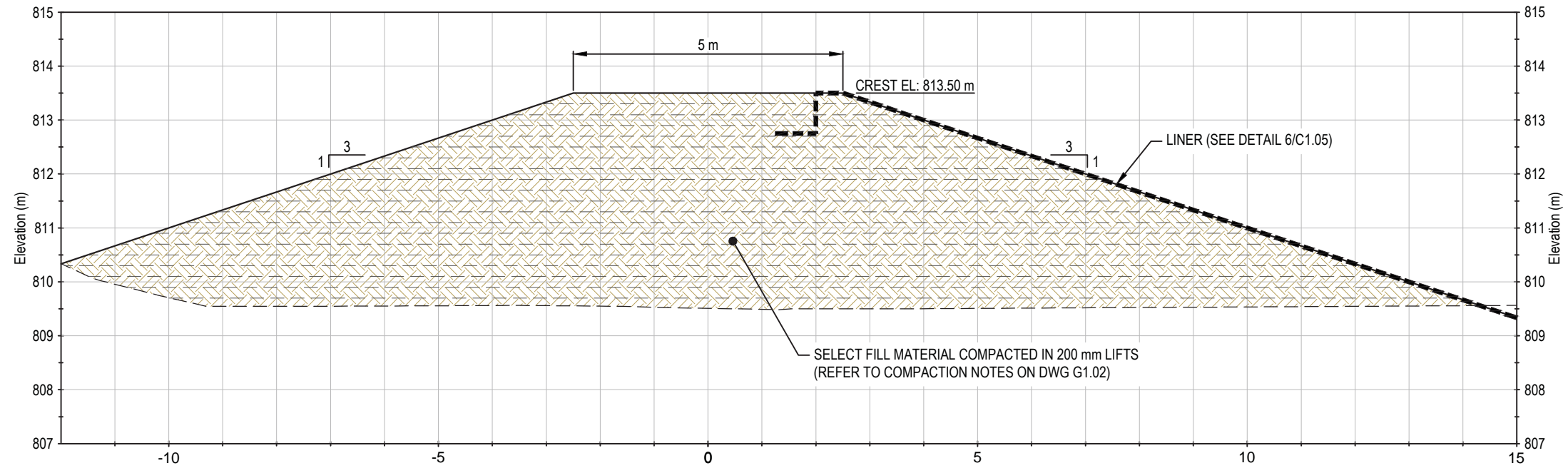

**A TYPICAL DAM SECTION**  
C1.03 SCALE: 1:100

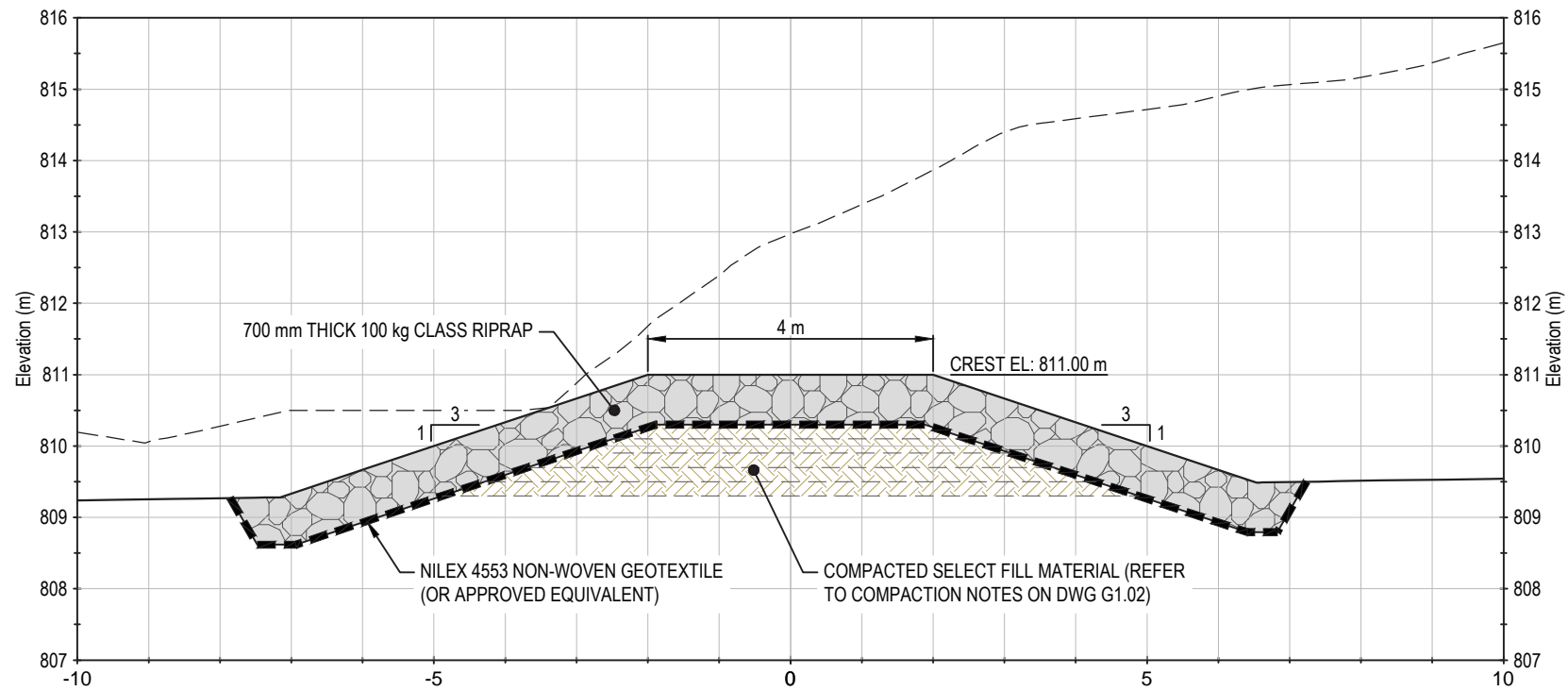

**B TYPICAL FOREBAY EMBANKMENT SECTION**  
C1.03 SCALE: 1:100

**LEGEND**

- Existing Ground
- Proposed Ground

**NOTES**

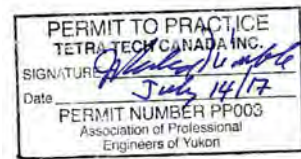

**ISSUED FOR CONSTRUCTION**

NUM	DATE	DWN	CKD	APR	DESCRIPTION
1	7/14/17	JDM	DH	MH	ISSUED FOR CONSTRUCTION
0	7/6/17	JDM	DH	MH	ISSUED FOR CONSTRUCTABILITY REVIEW

July 14, 2017

CLIENT

<b>WATER MANAGEMENT PLAN NELPCo EAGLE GOLD MINE, YT</b>					
<b>LOWER DUBLIN SOUTH POND TYPICAL SECTIONS</b>					
PROJECT NO. WTRM03037-01	OFFICE VANC	DES DH	CKD MH	REV 1	DRAWING C1.03
DATE July 14, 2017	SHEET No. of	DWN JDM	APP MH	STATUS IFC	

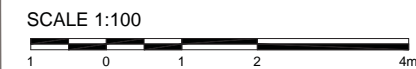



\\lcal\heta\Legacy\Vancover\Drafting\Transportation\WTRM03037-01 - Eagle Gold Design - R0.dwg [C1.04] July 14, 2017 - 12:23:48 pm (BY: MANG, JUSTIN)

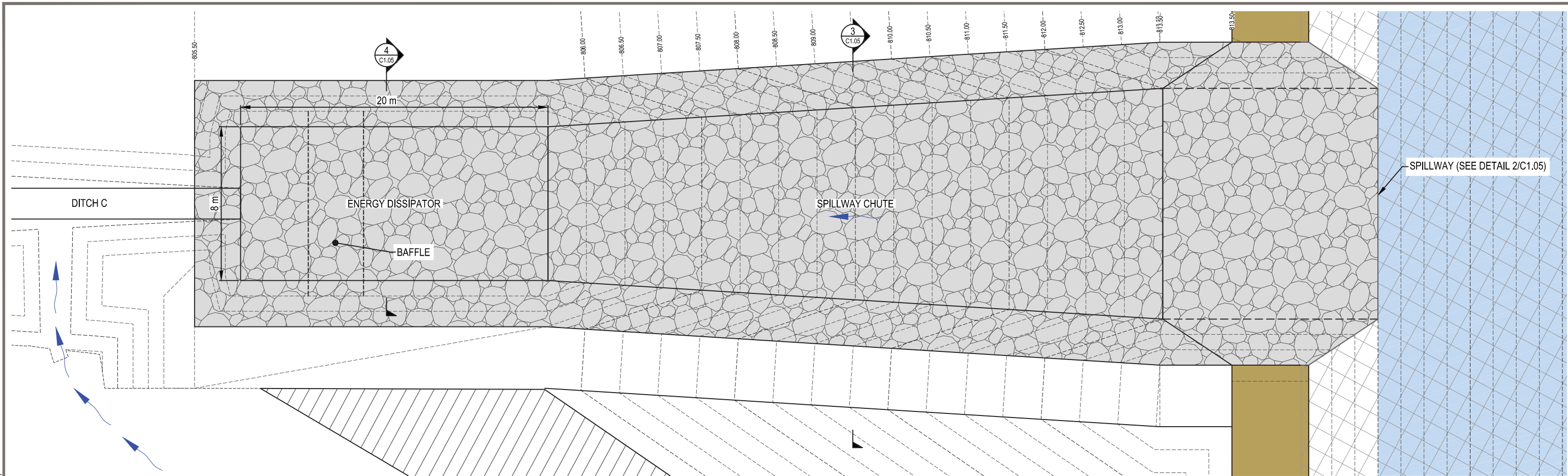

PLAN  
SCALE: 1:250

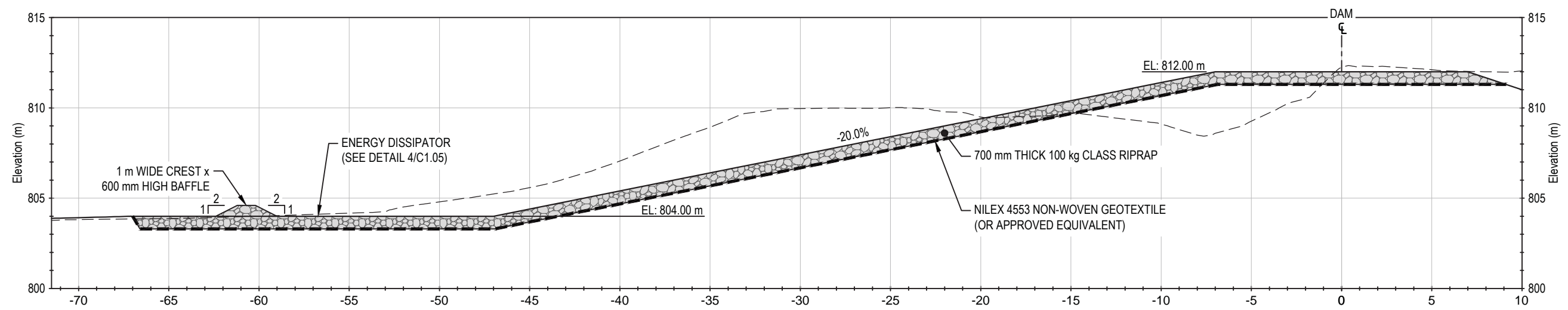

1 BERM CENTERLINE PROFILE  
C1.04 SCALE: 1:250

**LEGEND**  
 --- Existing Ground  
 — Proposed Ground

**NOTES**

PERMIT TO PRACTICE  
 TETRA TECH CANADA INC.  
 SIGNATURE: *[Signature]*  
 Date: July 14/17  
 PERMIT NUMBER PPO03  
 Association of Professional Engineers of Yukon

ISSUED FOR CONSTRUCTION

NUM	DATE	DWN	CKD	APR	DESCRIPTION
1	7/14/17	JDM	DH	MH	ISSUED FOR CONSTRUCTION
0	7/6/17	JDM	DH	MH	ISSUED FOR CONSTRUCTABILITY REVIEW

*[Signature]* P.ENG. (B.C.)  
 July 14, 2017  
 APPROVED

CLIENT

**StrataGold Corporation**

**TETRA TECH EBA**

WATER MANAGEMENT PLAN NELPCo EAGLE GOLD MINE, YT					
LOWER DUBLIN SOUTH POND SPILLWAY PLAN AND PROFILE					
PROJECT NO. WTRM03037-01	OFFICE VANC	DES DH	CKD MH	REV 1	DRAWING C1.04
DATE July 14, 2017	SHEET No. of	DWN JDM	APP MH	STATUS IFC	



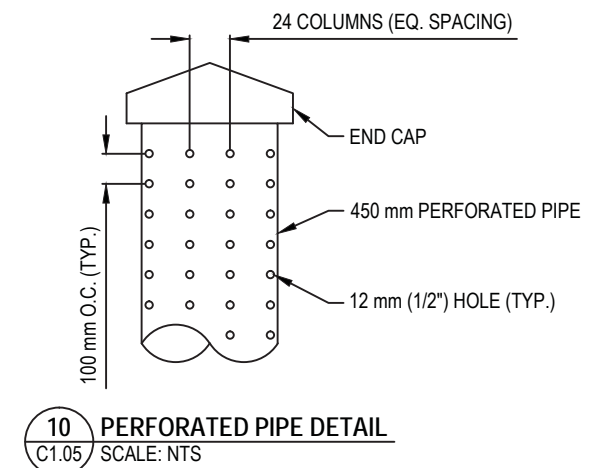
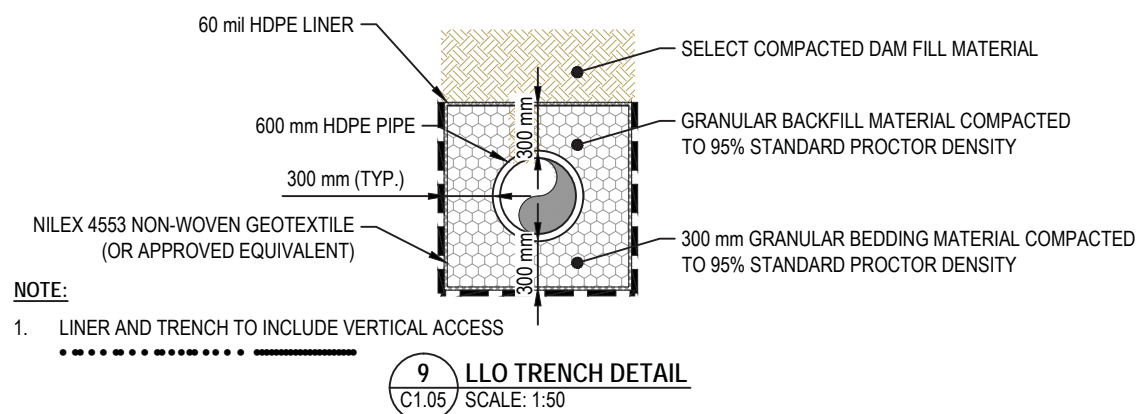
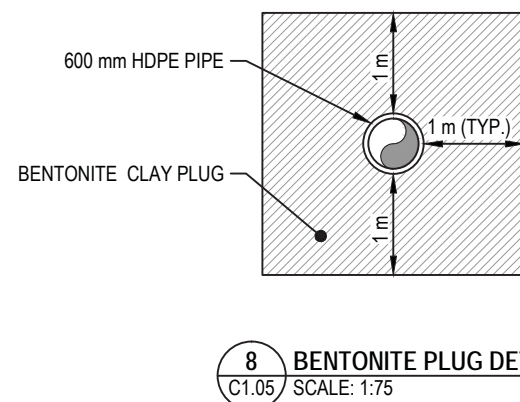
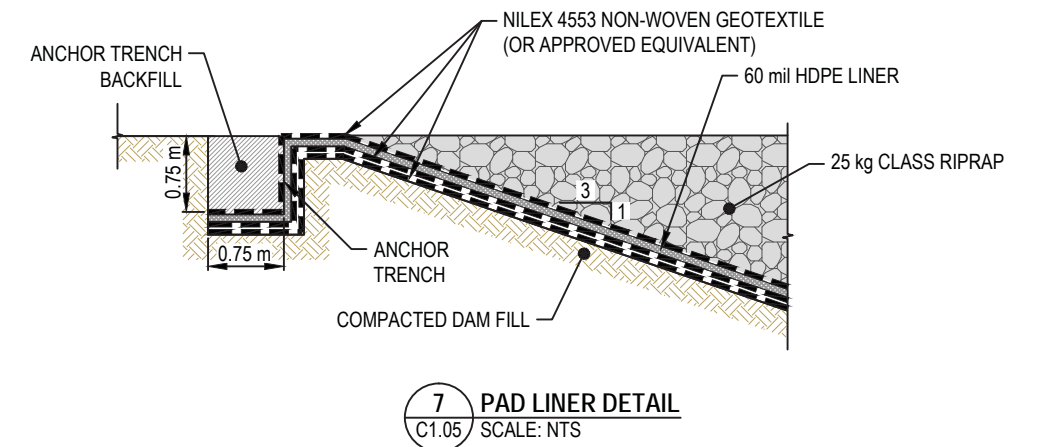
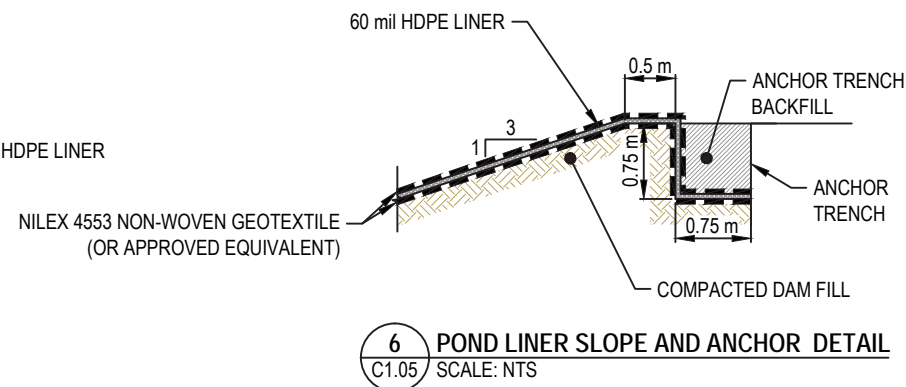
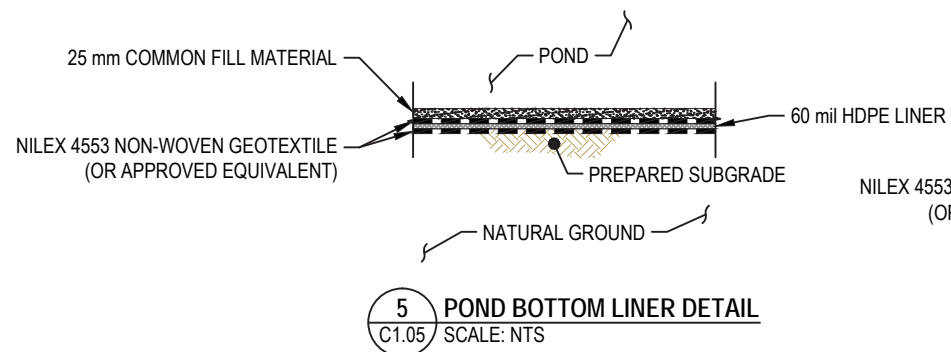
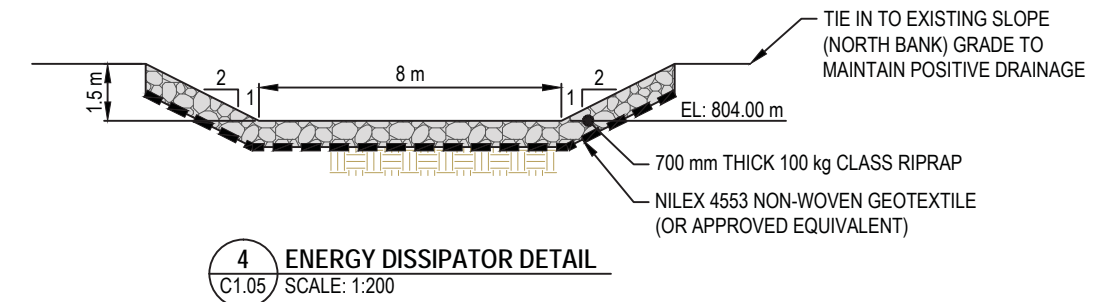
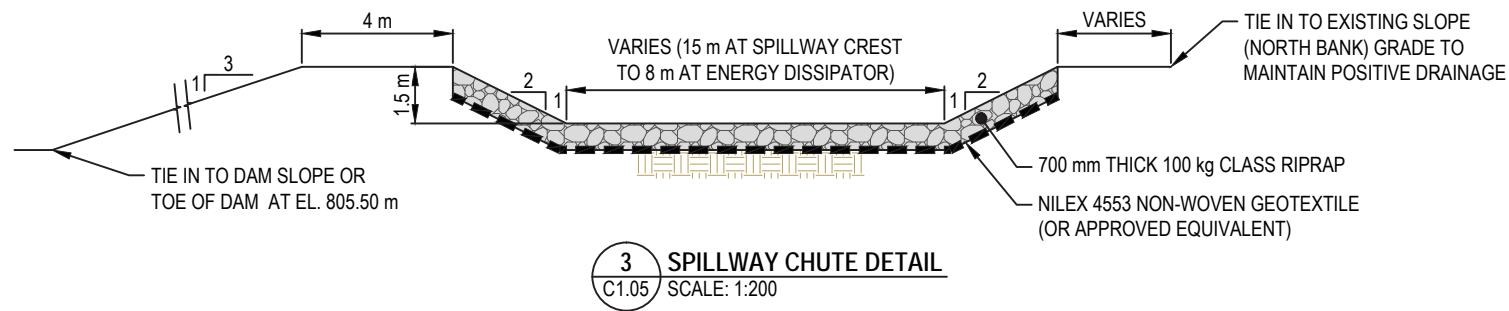
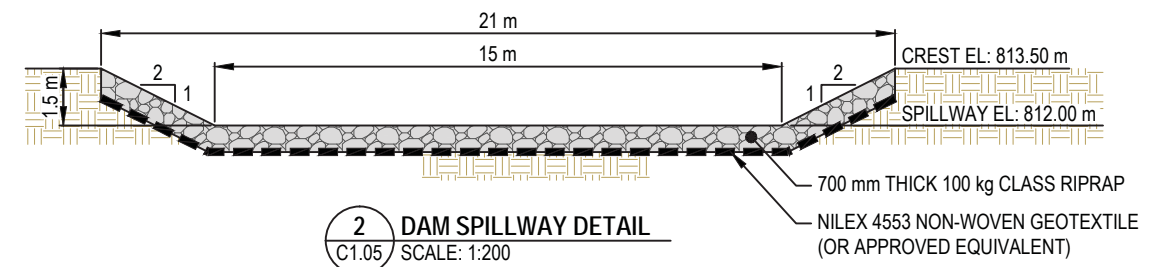
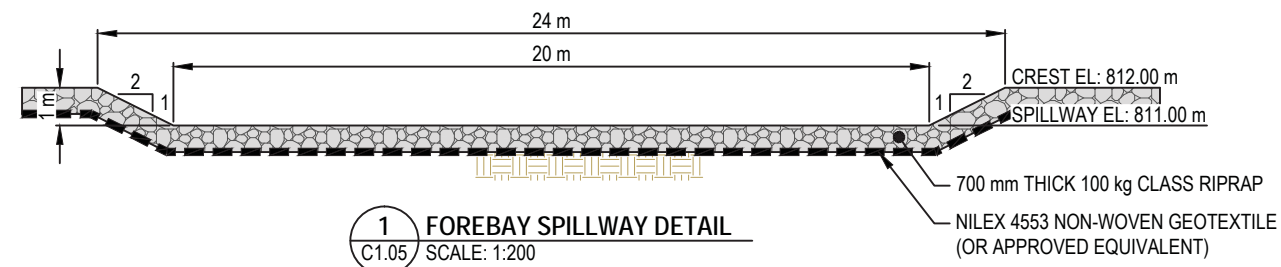

LEGEND

NOTES

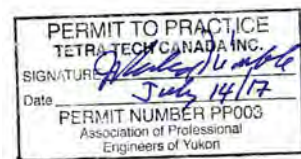

ISSUED FOR CONSTRUCTION

NUM	DATE	DWN	CKD	APR	DESCRIPTION
1	7/14/17	JDM	DH	MH	ISSUED FOR CONSTRUCTION
0	7/6/17	JDM	DH	MH	ISSUED FOR CONSTRUCTION REVIEW

Professional Seal: [Signature], P.ENG. (B.C.), July 14, 2017



WATER MANAGEMENT PLAN NELPCo EAGLE GOLD MINE, YT					
LOWER DUBLIN SOUTH POND SECTIONS & DETAILS					
PROJECT NO.	OFFICE	DES	CKD	REV	DRAWING
WTRM03037-01	VANC	DH	MH	1	C1.05
DATE	SHEET No. of	DWN	APP	STATUS	IFC
July 14, 2017		JDM	MH	IFC	



I:\local\heta\Legacy\Vancover\Drafting\Transportation\WTRM03037-01 - Eagle Gold Design - RD.dwg [C1.05] July 14, 2017 - 12:24:15 pm (BY: MANG, JUSTIN)

\\lcal\heta\Legacy\Drawings\Transportation\WTRM\WTRM03037-01 - Eagle Gold Design - R0.dwg [C1.06] July 14, 2017 - 12:48:40 pm (BY: MANG, JUSTIN)

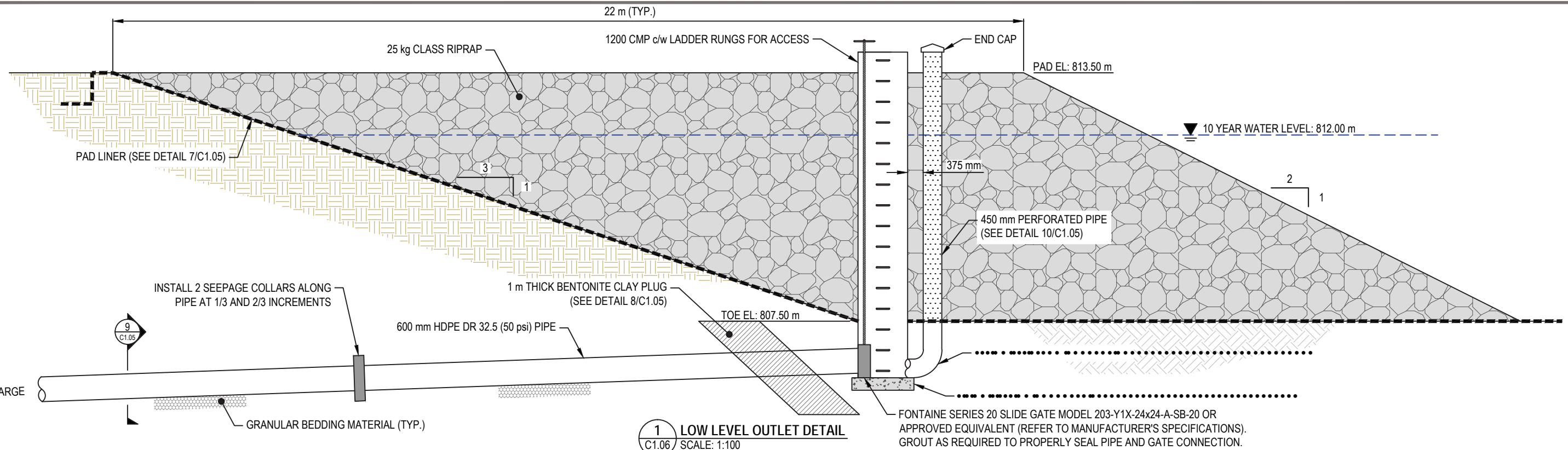

**1 LOW LEVEL OUTLET DETAIL**  
C1.06 SCALE: 1:100

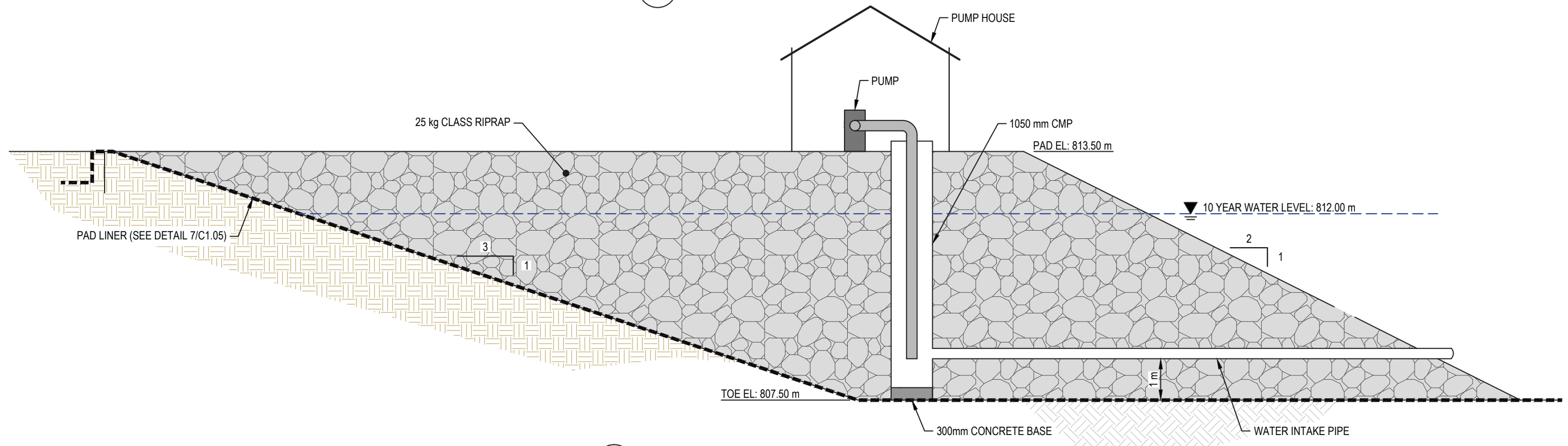

**2 PUMP HOUSE DETAIL (DESIGN BY OTHERS)**  
C1.06 SCALE: 1:100

**LEGEND**

**NOTES**

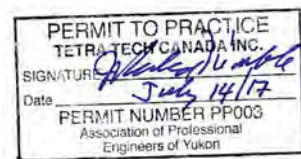

**ISSUED FOR CONSTRUCTION**

NUM	DATE	DWN	CKD	APR	DESCRIPTION
1	7/14/17	JDM	DH	MH	ISSUED FOR CONSTRUCTION
0	7/6/17	JDM	DH	MH	ISSUED FOR CONSTRUCTABILITY REVIEW

Planning Services P.ENG. (B.C.)
   
 July 14, 2017
   
 Approved

CLIENT

<b>WATER MANAGEMENT PLAN</b> <b>NELPCo EAGLE GOLD MINE, YT</b>					
<b>LOWER DUBLIN SOUTH POND</b> <b>LOW LEVEL OUTLET AND PUMP HOUSE</b>					
PROJECT NO.	OFFICE	DES	CKD	REV	DRAWING
WTRM03037-01	VANC	DH	MH	1	C1.06
DATE	SHEET No.	DWN	APP	STATUS	
July 14, 2017	of	JDM	MH	IFC	

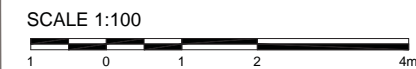

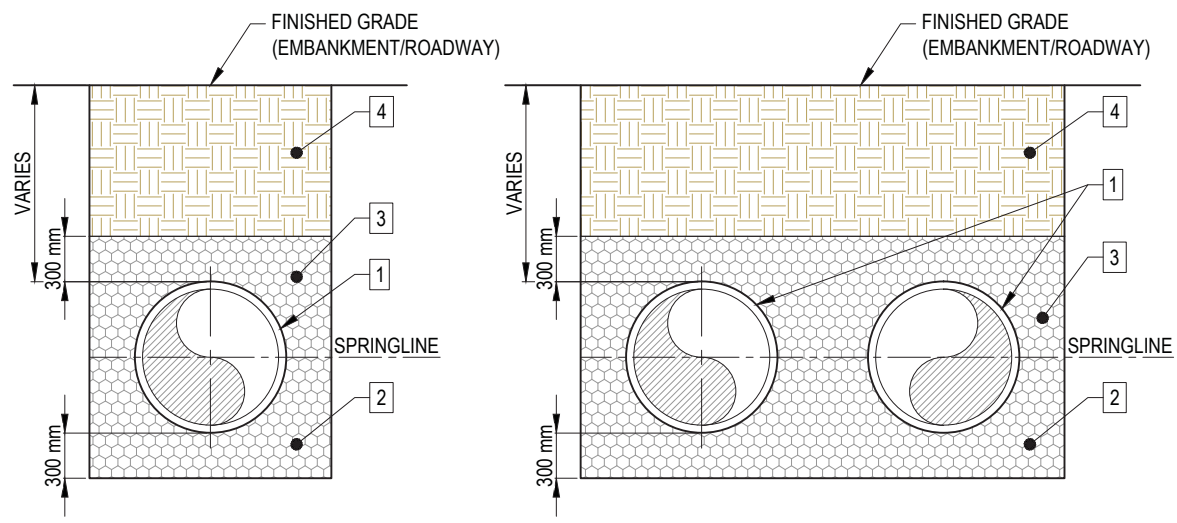

**NOTE:**  
1. MINIMUM COVER SHALL BE THE GREATER OF 400 mm OR 0.5x PIPE DIAMETER FOR LIGHT VEHICLE ROADS AND 1.5 m FOR HAUL ROADS.

**1 PIPE TRENCH DETAILS**  
C1.07 SCALE: NTS

- KEY NOTES:**
1. ALL CULVERTS SHALL BE CORRUGATED METAL PIPE (CMP) AND SHALL BE A MINIMUM OF 750 mm IN DIAMETER UNLESS NOTED OTHERWISE.
  2. GRANULAR BEDDING MATERIAL TO BE COMPACTED TO 95% STANDARD PROCTOR DENSITY.
  3. GRANULAR BACKFILL MATERIAL TO BE COMPACTED TO 95% STANDARD PROCTOR DENSITY.
  4. SELECT FILL MATERIAL IN EMBANKMENTS TO BE COMPACTED TO 95% STANDARD PROCTOR DENSITY. GENERAL FILL MATERIAL UNDER ROADWAYS TO BE COMPACTED TO 95% MODIFIED PROCTOR DENSITY.
  5. RIPRAP SHALL BE HAND PLACED COBBLE  $D_{50} = 150$  mm (MIN.)
  6. RIPRAP THICKNESS 600 mm (1400 mm - 2000 mm)
  7. NON-WOVEN GEOTEXTILE SHALL BE PLACED UNDER RIPRAP AT THE OUTLET OF CULVERT TO PREVENT SCOUR.

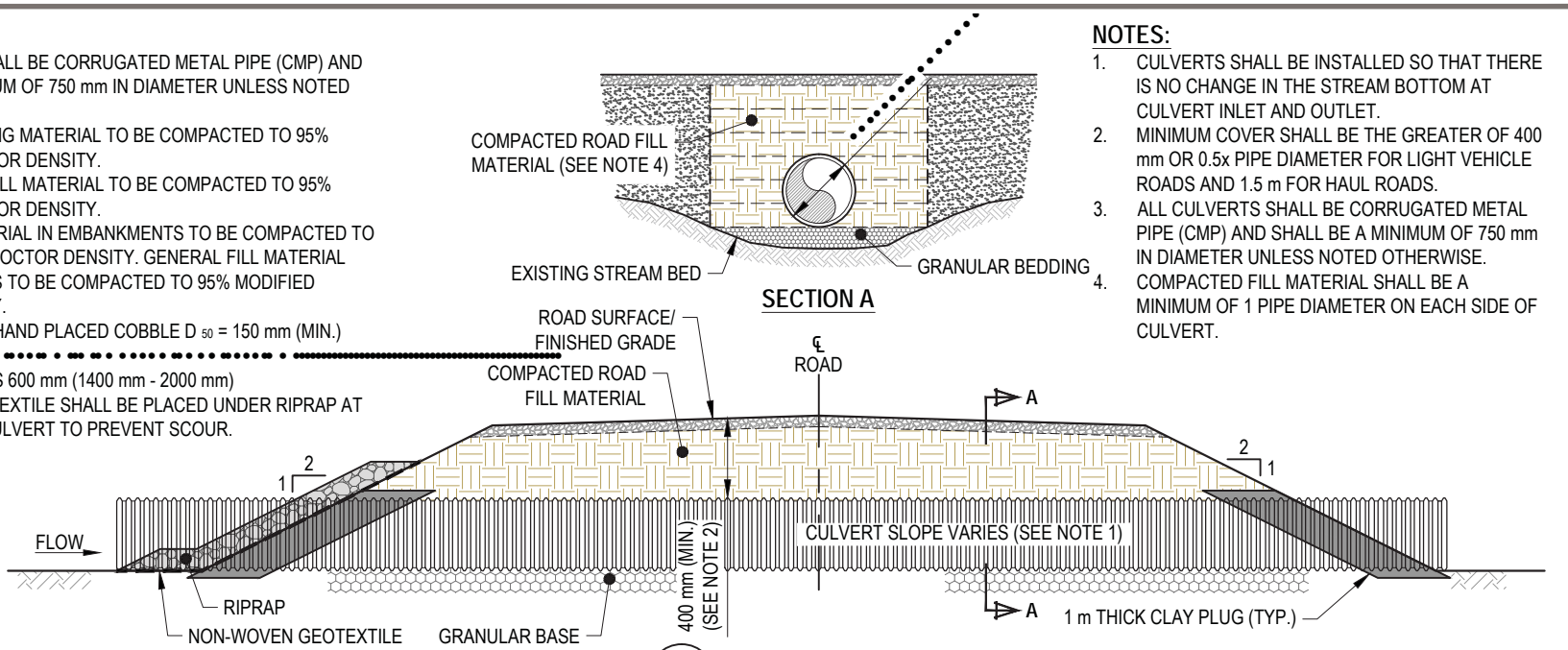

**2 TYPICAL CULVERT CROSSING**  
C1.07 SCALE: NTS

- NOTES:**
1. CULVERTS SHALL BE INSTALLED SO THAT THERE IS NO CHANGE IN THE STREAM BOTTOM AT CULVERT INLET AND OUTLET.
  2. MINIMUM COVER SHALL BE THE GREATER OF 400 mm OR 0.5x PIPE DIAMETER FOR LIGHT VEHICLE ROADS AND 1.5 m FOR HAUL ROADS.
  3. ALL CULVERTS SHALL BE CORRUGATED METAL PIPE (CMP) AND SHALL BE A MINIMUM OF 750 mm IN DIAMETER UNLESS NOTED OTHERWISE.
  4. COMPACTED FILL MATERIAL SHALL BE A MINIMUM OF 1 PIPE DIAMETER ON EACH SIDE OF CULVERT.

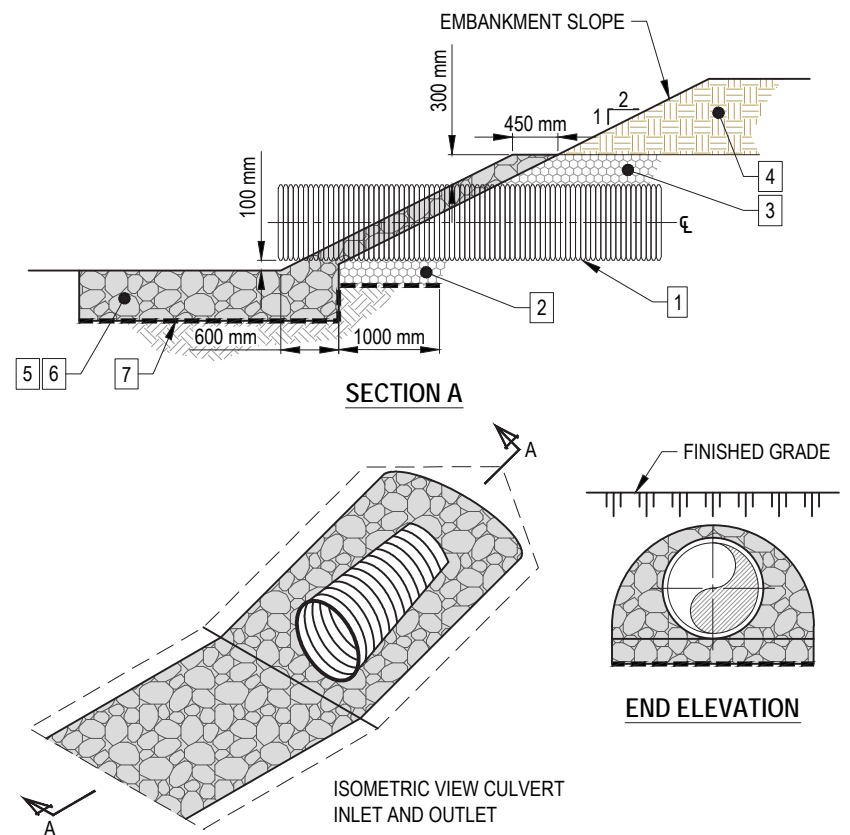

**3 TYPICAL HAND PLACED RIPRAP CULVERT END TREATMENT**  
C1.07 SCALE: NTS

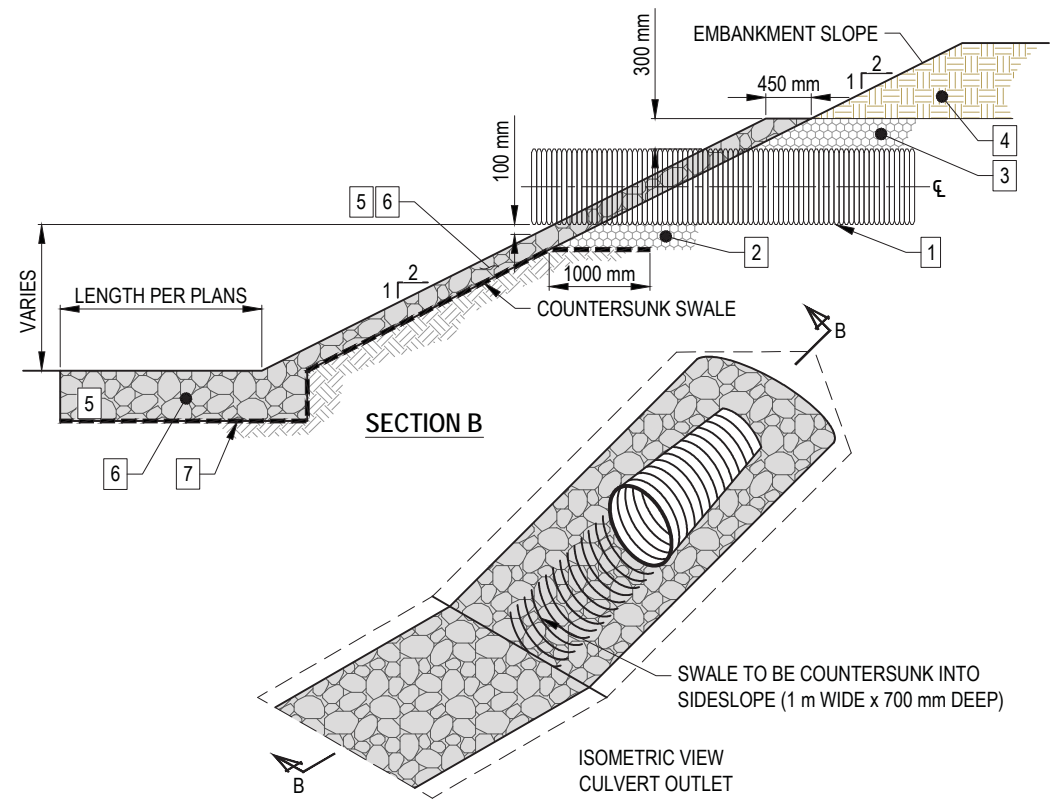

**4 TYPICAL SWALE CULVERT END TREATMENT**  
C1.07 SCALE: NTS

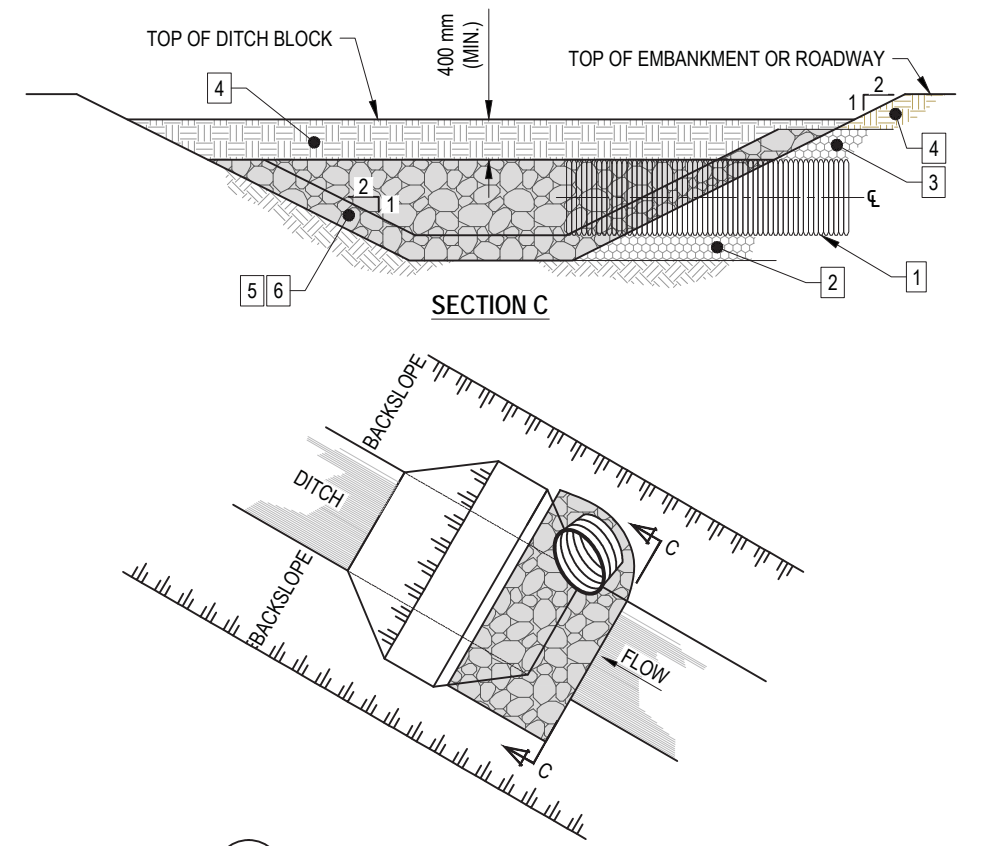

**5 TYPICAL DITCH BLOCK WITH CULVERT**  
C1.07 SCALE: NTS

I:\local\hella\Legacy\Vancover\Drafting\Transportation\WTRM03037-01 - Eagle Gold Details - RD.dwg [C1.07] July 14, 2017 - 12:25:58 pm (BY: MANG, JUSTIN)

LEGEND NOTES

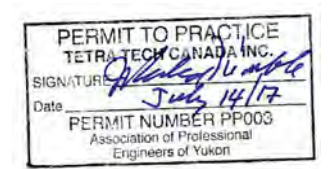

**ISSUED FOR CONSTRUCTION**

NUM	DATE	DWN	CKD	APR	DESCRIPTION
1	7/14/17	JDM	DH	MH	ISSUED FOR CONSTRUCTION
0	7/6/17	JDM	DH	MH	ISSUED FOR CONSTRUCTABILITY REVIEW

PROFESSIONAL SEAL  
  
 P. Peng (C.E.C.)  
 July 14, 2017

CLIENT

WATER MANAGEMENT PLAN NELPCo EAGLE GOLD MINE, YT					
CULVERT SECTIONS AND DETAILS					
PROJECT NO. WTRM03037-01	OFFICE VANC	DES DH	CKD MH	REV 1	DRAWING C1.07
DATE July 14, 2017	SHEET No. of	DWN JDM	APP MH	STATUS IFC	

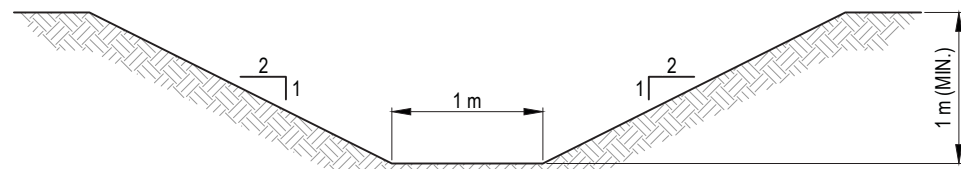

**TYPE 2 - UNLINED DITCH**

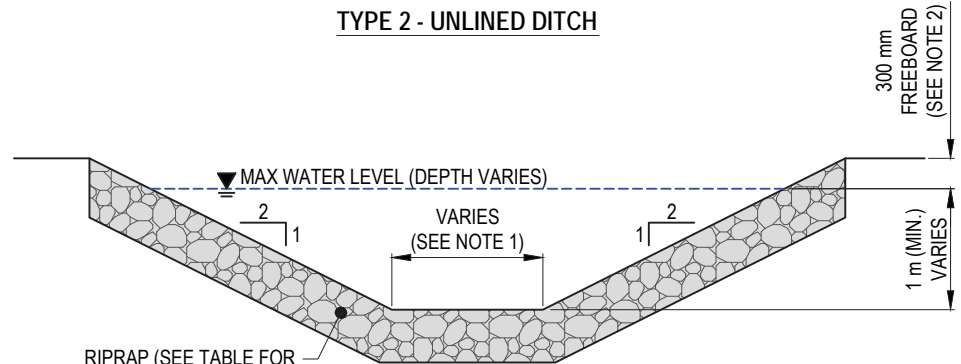

**TYPE 3 - RIPRAP DITCH**

RIPRAP TABLE			
DITCH TYPE	RIPRAP CLASS	RIPRAP THICKNESS	D <sub>50</sub>
TYPE 3A	10 kg	350 mm	195 mm
TYPE 3B	25 kg	450 mm	260 mm
TYPE 3C	50 kg	550 mm	330 mm
TYPE 3D	250 kg	1000 mm	565 mm
TYPE 3E	500 kg	1200 mm	715 mm

**NOTES:**

- FOR DITCH 'A' AND 'B' DITCH BOTTOM WIDTH SHALL BE 1 m AND FOR DITCH 'C' BOTTOM WIDTH SHALL BE 2 m.
- 300 mm FREEBOARD SHALL BE INCLUDED FOR ALL DITCH SECTIONS WHERE WATER DEPTH EXCEEDS 700 mm.

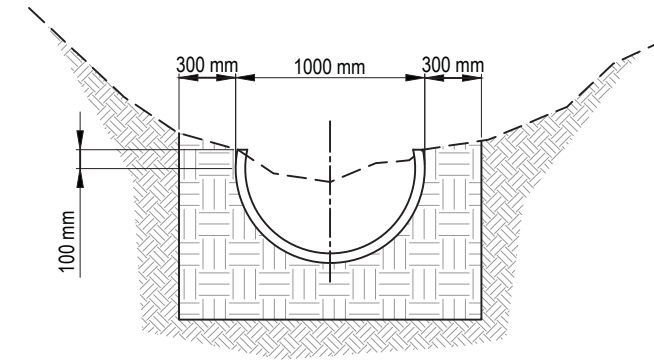

**1 DIVERSION AND COLLECTION DITCHES**  
C1.08 SCALE: NTS

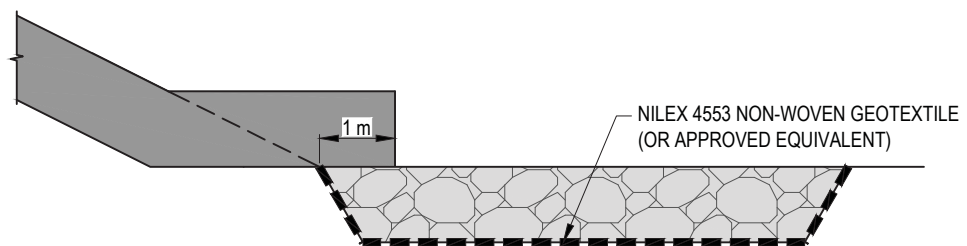
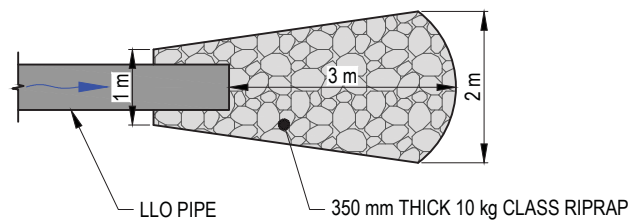
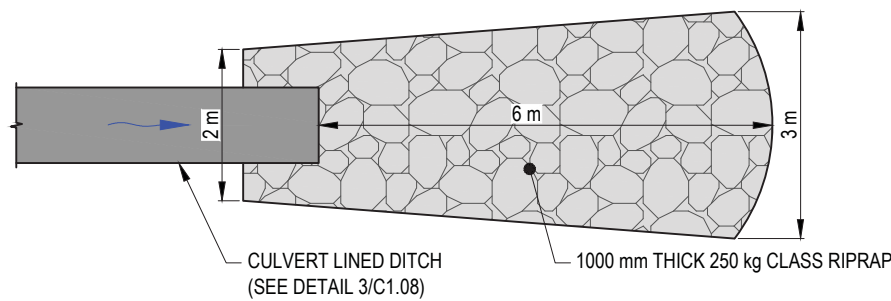

**DITCH A & B**

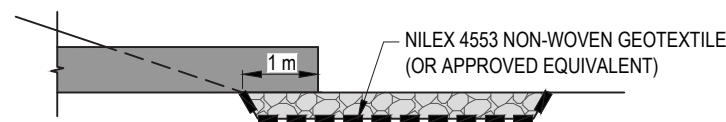

**LLO OUTLET**

**2 ROCK ENERGY DISSIPATOR**  
C1.08 SCALE: NTS

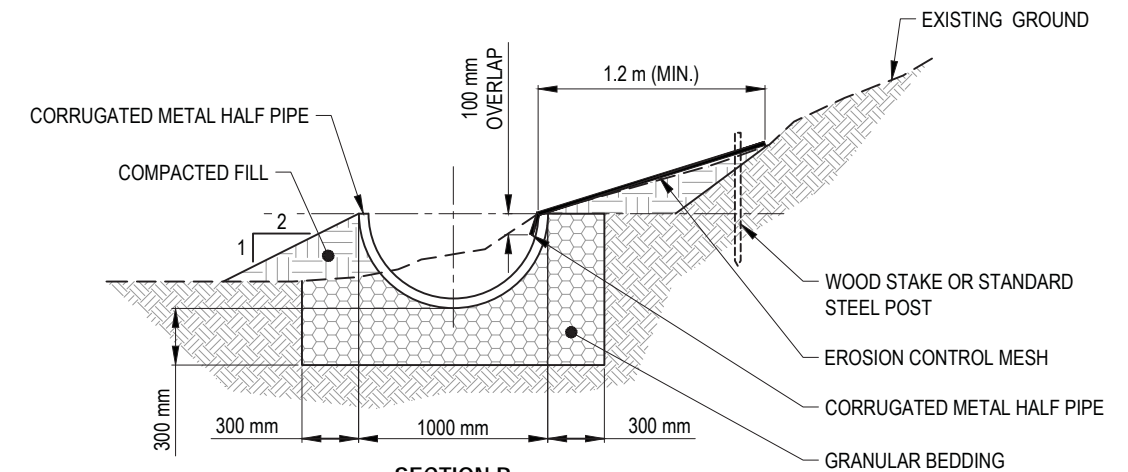
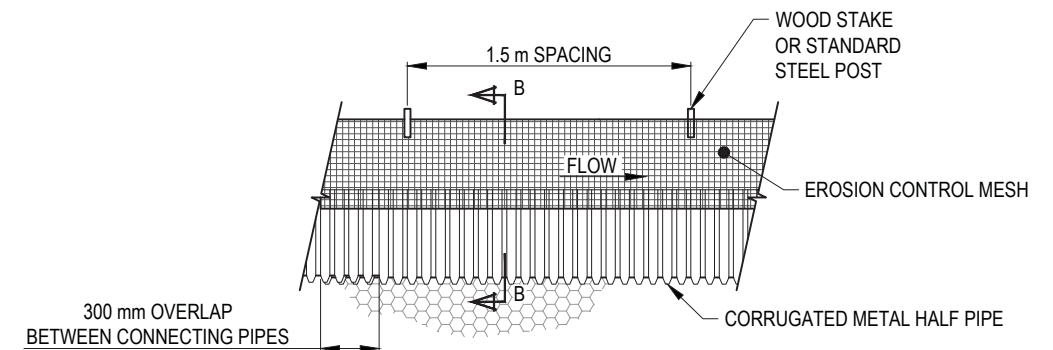

**SECTION B**

**3 CULVERT LINED DITCH**  
1.08 SCALE: NTS

**LEGEND**

**NOTES**



**ISSUED FOR CONSTRUCTION**

NUM	DATE	DWN	CKD	APR	REVISIONS	DESCRIPTION
1	7/14/17	JDM	DH	MH	ISSUED FOR CONSTRUCTION	
0	7/6/17	JDM	DH	MH	ISSUED FOR CONSTRUCTABILITY REVIEW	

PROFESSIONAL SEAL

CLIENT

**WATER MANAGEMENT PLAN**  
**NELPCo EAGLE GOLD MINE, YT**

**DITCH DETAILS**

PROJECT NO.	OFFICE	DES	CKD	REV	DRAWING
WTRM03037-01	VANC	DH	MH	1	C1.08
DATE	SHEET No. of	DWN	APP	STATUS	
July 14, 2017		JDM	MH	IFC	

Q:\Vancouver\Drafting\Transportation\WTRM\WTRM03037-01 - Eagle Gold Ditch Design - R1.dwg [FIGURE 1] August 10, 2018 - 11:01:51 am (BY: KIM, MIA)

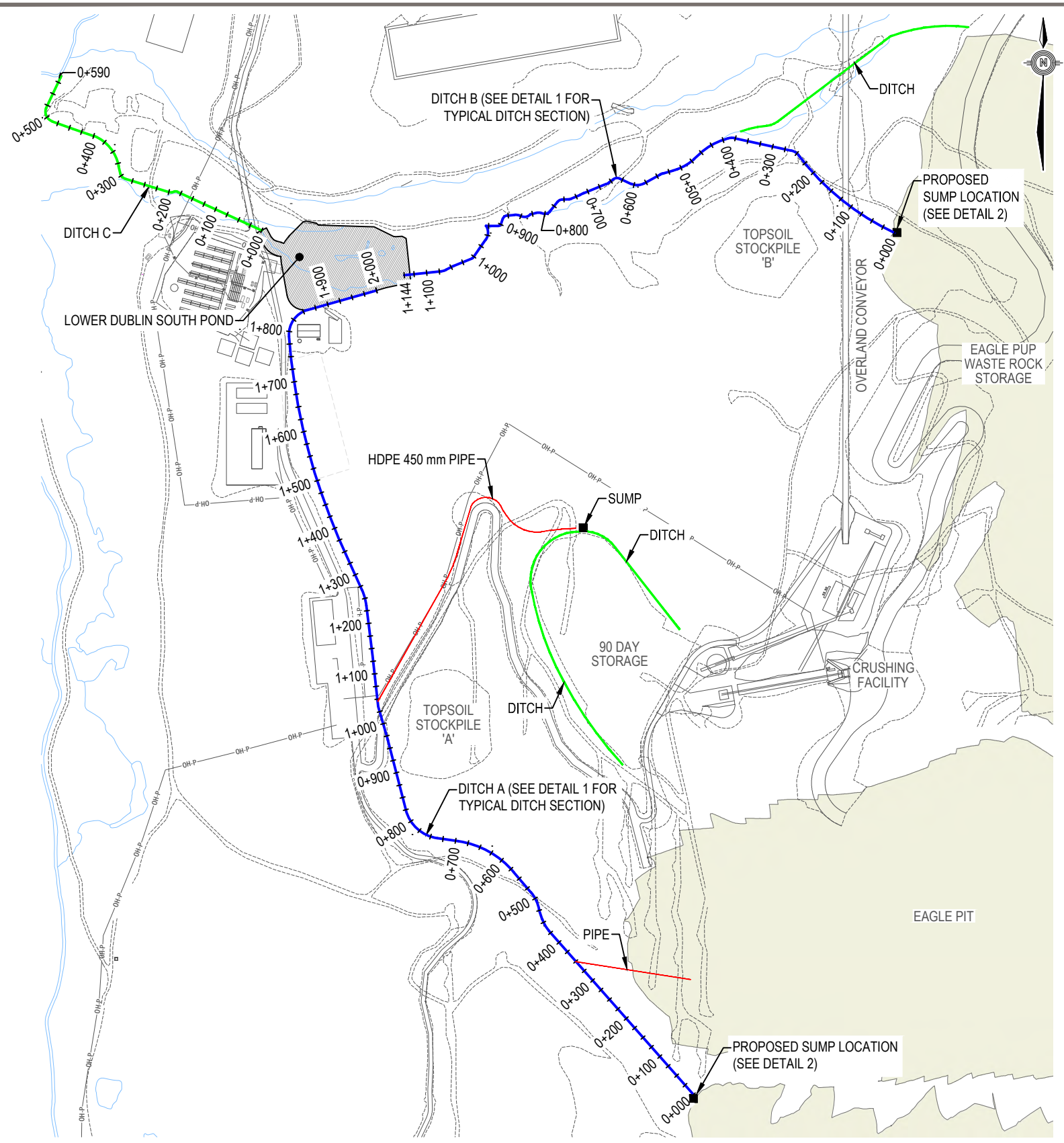

**LEGEND**  
— DITCH WITH PIPE  
— DITCH WITHOUT PIPE

**NOTES**

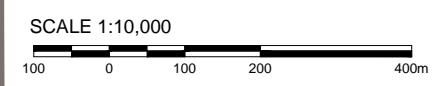

**ISSUED FOR REVIEW**

NUM	DATE	DWN	CKD	APR	DESCRIPTION
A	6/28/18	JDM	MH	MH	ISSUED FOR REVIEW
REVISIONS					

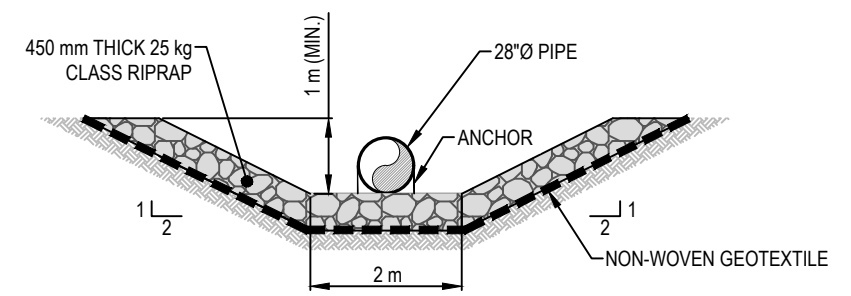

**1 TYPICAL DITCH DETAIL**  
 Fig.1 SCALE: 1:100

**NOTES:**

1. PIPE WILL DAYLIGHT WITHIN 30 m DOWNSTREAM OF THE SUMP.
2. PIPE WILL BE DRAINED AND VALVE CLOSED PRIOR TO WINTER.
3. FIRST 20 m OF PIPE TO INCLUDE PROVISIONS FOR THERMAL STEAMING OR HEAT TRACING.

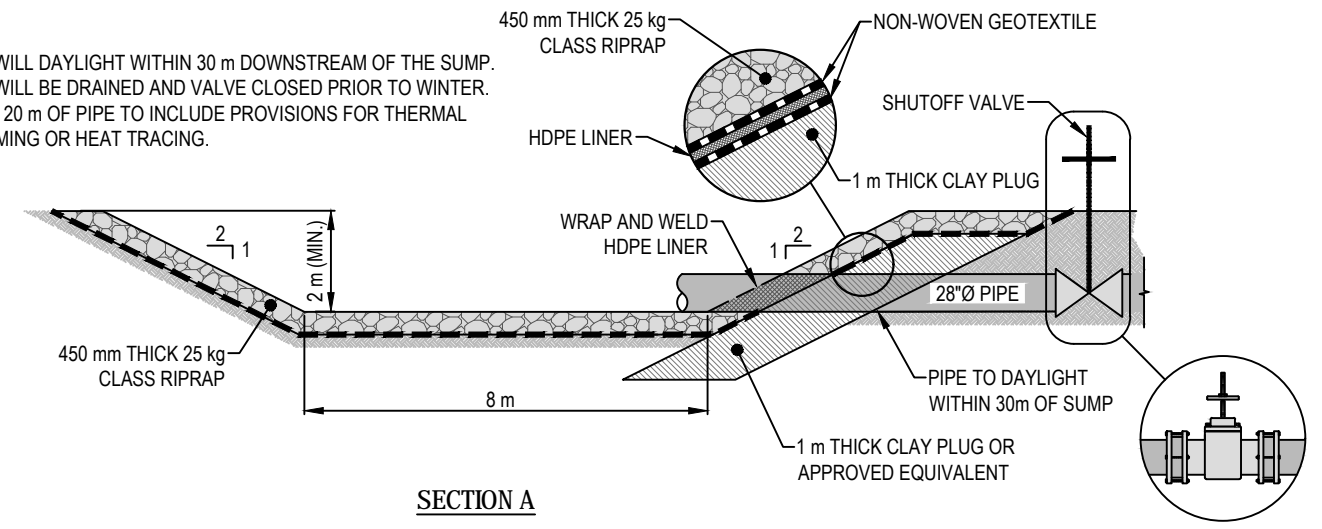

**SECTION A**

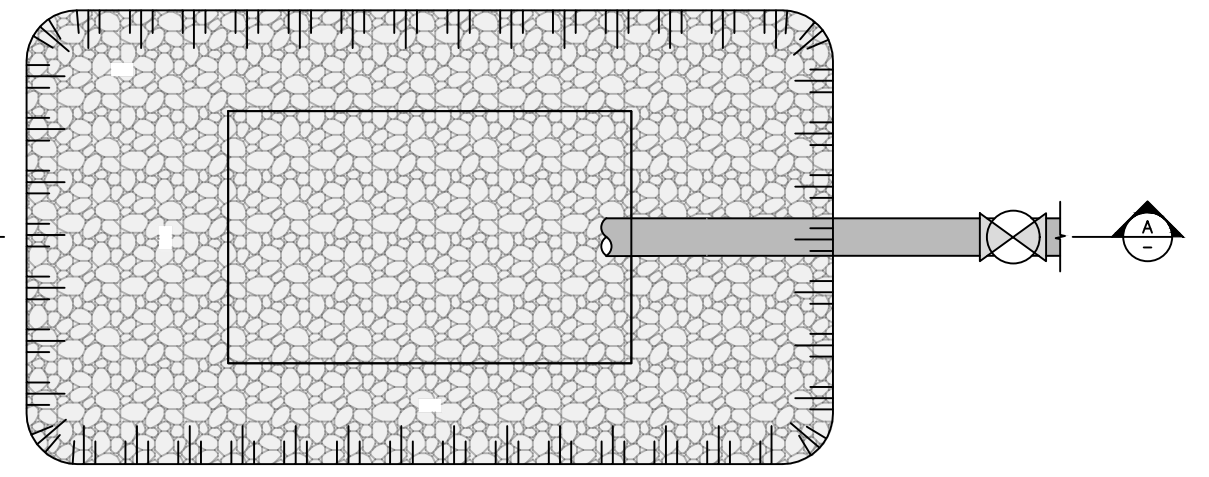

**2 5 m x 8 m SUMP DETAIL**  
 Fig.1 SCALE: 1:150

CLIENT

<b>WATER MANAGEMENT PLAN NELPCo EAGLE GOLD MINE, YT</b>					
<b>DITCH DESIGN</b>					
PROJECT NO. WTRM03037-01	OFFICE VANC	DES MH	CKD MH	REV A	DRAWING
DATE June 28, 2018	SHEET No. of	DWN JDM	APP MH	STATUS IFR	<b>Figure 1</b>

PROFESSIONAL SEAL

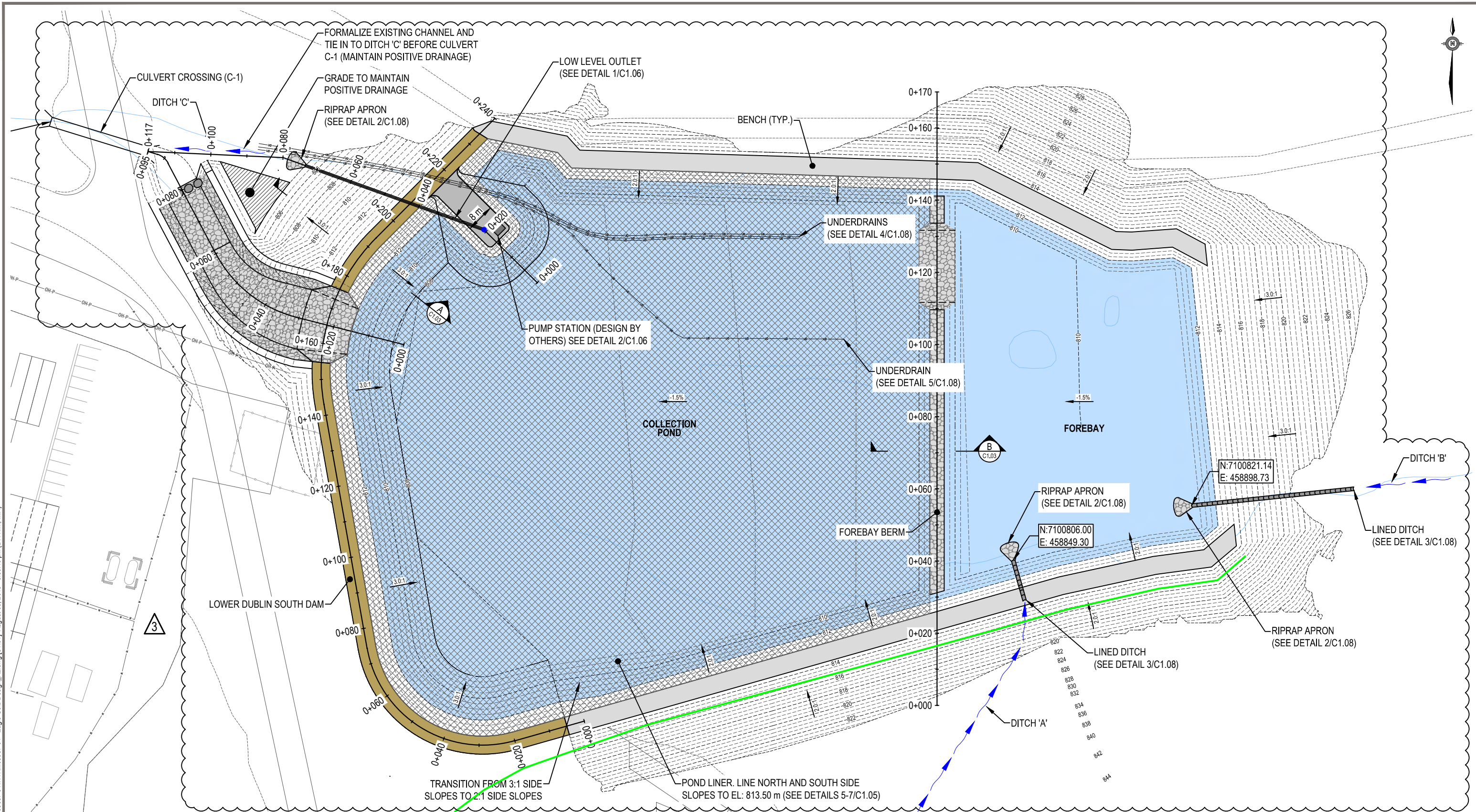

Q:\Vancouver\Drafting\Transportation\WTRM\WTRM03037-01 - Eagle Gold Design - P2.dwg [C1.01] August 08, 2018 - 3:55:40 pm (BY: KIM, MIA)

- LEGEND**
- Design Major Contours (2 m)
  - - - Design Minor Contours (0.5 m)

**NOTES**

PERMIT TO PRACTICE  
TETRA TECH CANADA INC.  
SIGNATURE: *[Signature]*  
Date: *July 14/17*  
PERMIT NUMBER PPO03  
Association of Professional Engineers of Yukon

**ISSUED FOR CONSTRUCTION**

NUM	DATE	DWN	CKD	APR	REVISIONS	DESCRIPTION
3	10/20/17	JDM	DH	MH	DESIGN CHANGE 002	
2	9/29/17	JDM	DH	MH	DESIGN CHANGE 001	
1	7/14/17	JDM	DH	MH	ISSUED FOR CONSTRUCTION	
0	7/6/17	JDM	DH	MH	ISSUED FOR CONSTRUCTABILITY REVIEW	



**WATER MANAGEMENT PLAN  
NELPCo EAGLE GOLD MINE, YT**

**LOWER DUBLIN SOUTH POND  
PLAN**

PROJECT NO. WTRM03037-01	OFFICE VANC	DES DH	CKD MH	REV 3	DRAWING C1.01
DATE October 31, 2017	SHEET No. of	DWN JDM	APP MH	STATUS IFC	

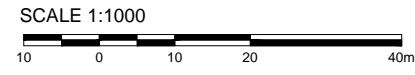

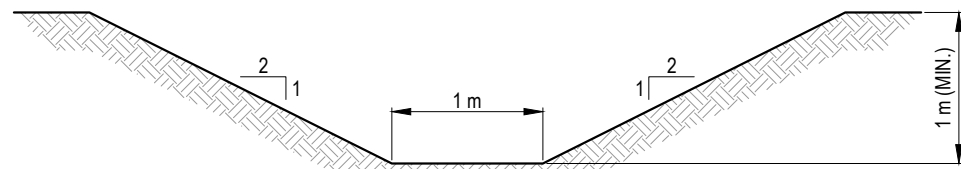

**TYPE 2 - UNLINED DITCH**

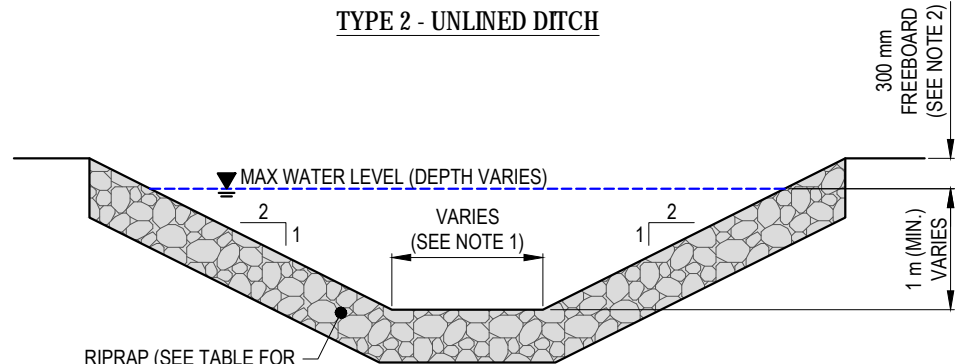

**TYPE 3 - RIPRAP DITCH**

RIPRAP TABLE			
DITCH TYPE	RIPRAP CLASS	RIPRAP THICKNESS	D <sub>50</sub>
TYPE 3A	10 kg	350 mm	195 mm
TYPE 3B	25 kg	450 mm	260 mm
TYPE 3C	50 kg	550 mm	330 mm
TYPE 3D	250 kg	1000 mm	565 mm
TYPE 3E	500 kg	1200 mm	715 mm

**NOTES:**

- FOR DITCH 'A' AND 'B' DITCH BOTTOM WIDTH SHALL BE 1 m AND FOR DITCH 'C' BOTTOM WIDTH SHALL BE 2 m.
- 300 mm FREEBOARD SHALL BE INCLUDED FOR ALL DITCH SECTIONS WHERE WATER DEPTH EXCEEDS 700 mm.

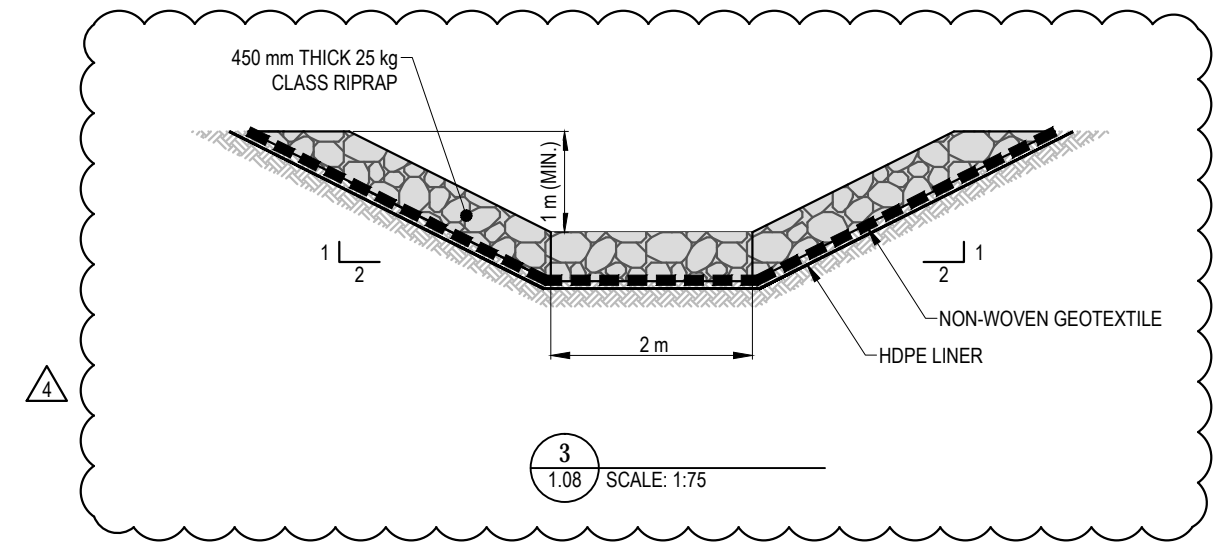

**1 DIVERSION AND COLLECTION DITCHES**  
C1.08 SCALE: NTS

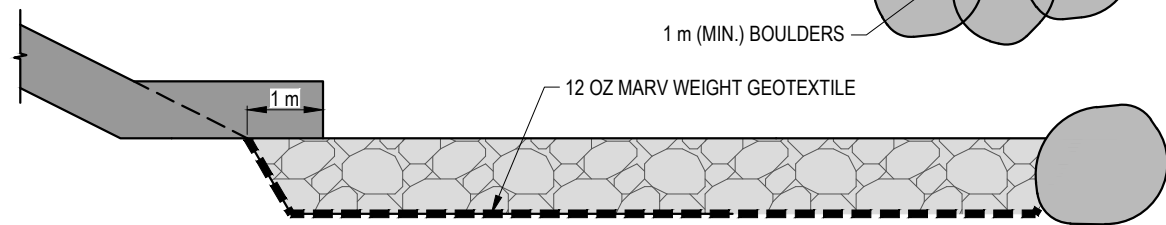
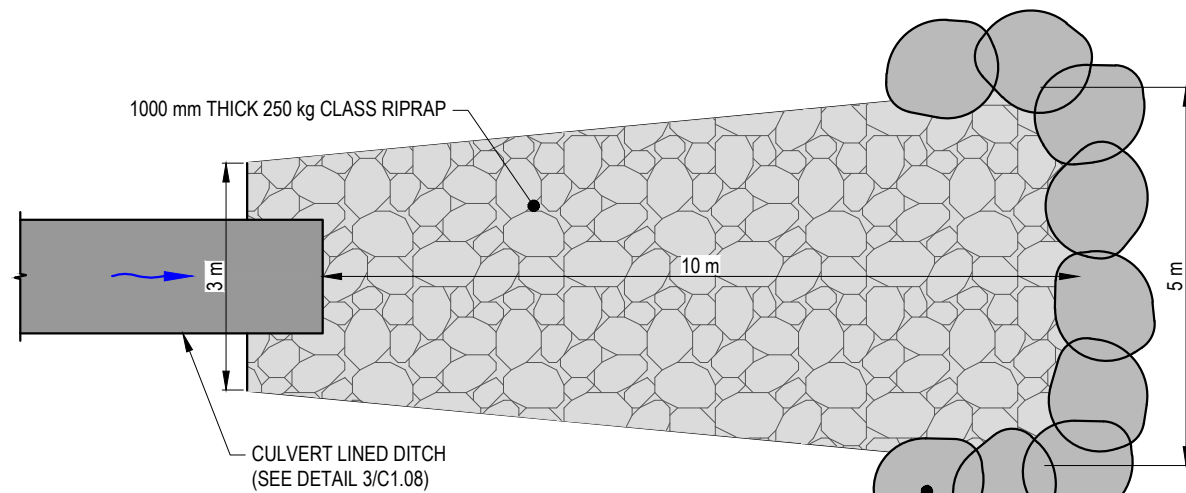

**DITCH A & B**

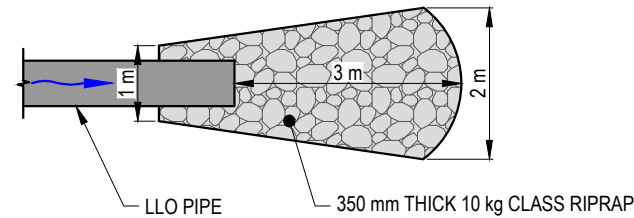

**LLO OUTLET**

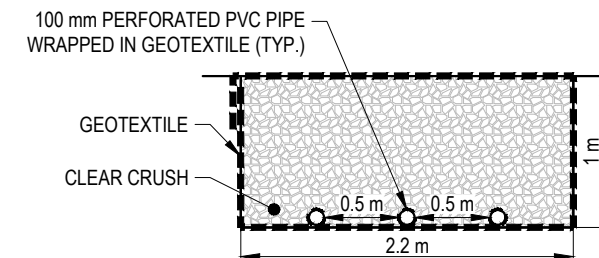

**4 TRENCH DRAIN DETAIL**  
1.08 SCALE: 1:50

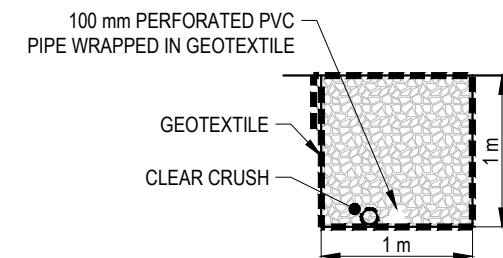

**5 TRENCH DRAIN DETAIL**  
1.08 SCALE: 1:50

**2 ROCK ENERGY DISSIPATOR**  
C1.08 SCALE: NTS

**LEGEND**

**NOTES**

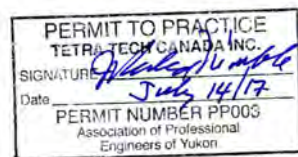

**RECORD DRAWING**

NUM	DATE	DWN	CKD	APR	DESCRIPTION
4	8/2/18	MJK	DH	MH	DESIGN CHANGE 002
3	1/26/18	JDM	DH	MH	RECORD DRAWING
2	9/29/17	JDM	DH	MH	DESIGN CHANGE 001
1	7/14/17	JDM	DH	MH	ISSUED FOR CONSTRUCTION
0	7/6/17	JDM	DH	MH	ISSUED FOR CONSTRUCTABILITY REVIEW



**WATER MANAGEMENT PLAN  
NELPCo EAGLE GOLD MINE, YT**

**DITCH DETAILS**

PROJECT NO.	OFFICE	DES	CKD	REV	DRAWING
WTRM03037-01	VANC	DH	MH	3	C1.08
DATE	SHEET No. of	DWN	APP	STATUS	REC
January 26, 2018		JDM	MH	REC	

Q:\Vancouver\Drafting\Transportation\WTRM\WTRM03037-01 - Eagle Gold Details\_R1.dwg [C1.08] August 02, 2018 - 1:08:24 pm (BY: KIM, MA)