



EAGLE GOLD MINE

WATER MANAGEMENT PLAN

Version 2024-01

MARCH 2024

THIS PAGE INTENTIONALLY LEFT BLANK

DOCUMENT CONTROL

Submission History

Version Number	Version Date	Document Description and Revisions Made
2013-01	September 2013	Original submission to support a potential construction phase of the Mine under a Type B WUL prior to receipt of a Type A WUL
2014-01	August 2014	Revisions for Type A WUL application and to encompass full scope of construction and operations.
2015-01	February 2015	Revisions made based on information requests and VGC responses during the adequacy review period for the Type A WUL application.
2017-01	July 2017	Revision based on optimized site layout and in support of the amendment application for the Type A WUL.
2018-01	August 2018	Revisions made based on information requests and VGC responses during the adequacy review period for the Type A WUL amendment application.
2020-01	January 2020	Revision to address clauses 100 and 101 of QZ14-41-1.
2024-01	March 2024	Revisions made to reflect as-built Mine configuration and to address Yukon Government review comments dated January 30, 2023.

Version 2024-01 of the Water Management Plan (the Plan) for the Eagle Gold Mine has been revised in March 2024 to update Version 2020-01 submitted in January 2020. The table below is intended to identify modifications to the Plan and provide the rationale for such modifications.

Version 2024-01 Revisions

Section	Revision/Rationale
General	<ul style="list-style-type: none"> Updated to Victoria Gold Corp. template
1 Introduction	<ul style="list-style-type: none"> Updated description of the current status of major mine facilities and water management infrastructure on site. Update to General Arrangement Figure to show the current status and configuration of the Mine.
1.2 Mine Schedule	<ul style="list-style-type: none"> Revision to the Mine Schedule Controls on Water Management Strategies to acknowledge the current status of the mine. Minor clarification to discussion of activities in each phase.
1.4 Scope of Plan	<ul style="list-style-type: none"> Minor text revisions to explain the expanded scope and considerations included in the Plan.
2.3.1 Roles and Responsibilities	<ul style="list-style-type: none"> Update to current position titles and responsibilities under the Plan.
2.3.3 Engineers of Record	<ul style="list-style-type: none"> Update to current EoR list.
3 Environmental Conditions	<ul style="list-style-type: none"> Update with environmental data generally to the end of 2023.

Section	Revision/Rationale
4 Design Basis and Criteria	<ul style="list-style-type: none"> ▪ Minor revisions to text to describe as built facilities. ▪ Update to site figures to show as built facilities.
5 Water Balance, Storm Water & Groundwater	<ul style="list-style-type: none"> ▪ Update to describe additional water balance model and flow measurement considerations.
5.1 Water, Pond and Solution Inventory Monitoring Program	<ul style="list-style-type: none"> ▪ New section to describe operational water level and flow transfer monitoring programs and their use.
5.2 Site Water Balance and Analyses Program	<ul style="list-style-type: none"> ▪ New section to describe how daily data collection is utilized for operational monitoring and more formal model validation.
5.3 Sitewide Surface Water Balance Model	<ul style="list-style-type: none"> ▪ Completion revision to provide more detail with respect to SWBM development, inputs and capabilities.
5.4 Heap Leach Water Balance Model	<ul style="list-style-type: none"> ▪ Expanded discussion of HLF WBM inputs and capabilities.
5.5 Sitewide Water Quality Model	<ul style="list-style-type: none"> ▪ Revision to reflect current SWQM inputs and capabilities.
5.6 Sitewide Numerical Groundwater Model	<ul style="list-style-type: none"> ▪ Revision to reflect current model inputs and capabilities.
5.7 Storm Water Model	<ul style="list-style-type: none"> ▪ Minor revisions for readability.
6 Mine Water Management Implementation	<ul style="list-style-type: none"> ▪ Minor revisions to text to describe as built facilities. ▪ Inclusion of Water Quality Objectives
6.1 Key Water Management Facilities	<ul style="list-style-type: none"> ▪ Revision to figure to reflect current as built facilities. ▪ Significant revision to description of facilities, to reflect as built status, and operational management of water to align with current practices.
6.2 Key Water Management Hydrometric Stations and Transfer Monitoring with the Mine Footprint	<ul style="list-style-type: none"> ▪ New section to describe water routing and flow measurement locations within the Mine footprint.
6.3 Water Management Triggers and Actions	<ul style="list-style-type: none"> ▪ New section providing analysis of measured inflows, precipitation events and transfer and treatment capabilities that are subsequently used to inform pond triggers for management actions.

Section	Revision/Rationale
6.4 Other Water Management Structures	<ul style="list-style-type: none">Formerly section 6.1.2 updated to describe current as built minor structures.
6.6 Erosions and Sediment Control Plan Implementation	<ul style="list-style-type: none">Minor revision to describe current approach to erosion and sediment control.
6.8 Water Uses	<ul style="list-style-type: none">Revision to provide updated consumption rates based on monitoring data.
6.10 Maintenance and Monitoring Strategies	<ul style="list-style-type: none">Revision to describe current approaches to maintenance and monitoring.

TABLE OF CONTENTS

1	Introduction	1
1.1	Mine Location and Background	2
1.2	Mine Schedule	5
1.3	Definitions	5
1.4	Scope of Plan	5
2	Water Management Planning.....	7
2.1	Objectives	7
2.2	Strategies	7
2.3	Execution Strategy	8
2.3.1	Roles and Responsibilities	8
2.3.2	Responsibility, Accountability, Consultation and Information.....	10
2.3.3	Engineers of Record.....	13
3	Environmental Conditions	15
3.1	Regional Setting.....	15
3.2	Climate	15
3.2.1	Mine Site.....	15
3.2.2	Temperature	18
3.2.3	Potential Evaporation	18
3.2.4	Precipitation.....	19
3.2.5	Snow Accumulation and Snowmelt.....	22
3.2.6	Extreme Rainfall	23
3.2.7	Snowmelt.....	25
3.3	Physiography	27
3.4	Surface Water	27
3.4.1	Streamflow.....	27
3.4.2	Surface Water Quality	32
3.4.2.1	Dublin Gulch Drainage	32
3.4.2.2	Eagle Creek Drainage.....	34
3.4.2.3	Haggart Creek Drainage	35
3.5	Groundwater	37
3.5.1	Hydrogeologic Setting	38
3.5.2	Groundwater Occurrence and Groundwater Level Monitoring	38
3.5.2.1	Sitewide Groundwater Level Monitoring	38
3.5.2.2	Eagle Pit Depressurization Drainholes	41
3.5.2.3	Eagle Pit Depressurization Monitoring.....	41

3.5.3	Groundwater Flow	43
3.5.4	Surface Water - Groundwater Connectivity.....	44
3.5.5	Groundwater Flow Properties.....	44
3.5.6	Groundwater Quality	45
3.5.6.1	General Characterization	45
3.5.6.2	2017 Statistical Characterization of Baseline Groundwater Data	46
3.5.6.3	Groundwater Quality Monitoring	46
4	Design Basis and Criteria	54
4.1	Storm Water Design Criteria	54
4.2	Sediment and Control Erosion	57
4.2.1	Sediment and Erosion Sources.....	57
4.2.2	Best Management Practices	58
4.2.2.1	Vegetation Management	58
4.2.2.2	Soil Bioengineering	58
4.2.2.3	Mulching.....	59
4.2.2.4	Rolled Erosion Control Products.....	59
4.2.2.5	Surface Roughening	59
4.2.2.6	Re-contouring.....	60
4.2.2.7	Silt Fencing.....	60
4.2.2.8	Temporary Sediment Traps and Sediment Basins	60
4.2.2.9	Filter Bags and Geotubes	61
4.2.2.10	Flocculants	61
4.2.2.11	Collection Ditches	62
4.2.2.12	Diversion Ditches	62
4.2.2.13	Roadside Berms and Ditches.....	62
4.2.2.14	Culverts	63
4.2.2.15	Exfiltration Areas	63
4.3	Discharge Protocols.....	67
5	Water Balance, Storm Water & Groundwater	68
5.1	Water, Pond and Solution Inventory Monitoring Program	69
5.2	Site Water Balance and Analyses Program.....	70
5.3	Sitewide Surface Water Balance Model.....	70
5.4	Heap Leach Water Balance Model	71
5.4.1	Deterministic Model.....	72
5.4.2	Stochastic Model	72
5.4.3	Operational Model	73
5.5	Sitewide Water Quality Model.....	73

Table of Contents

5.6	Sitewide Numerical Groundwater Model.....	73
5.6.1	Mine Groundwater Model Development.....	73
5.6.2	Model Results.....	74
5.6.2.1	Open Pit Advance and Mine Dewatering.....	74
5.6.2.2	Groundwater Supply Extraction.....	74
5.6.2.3	Flow in Haggart Creek.....	74
5.7	Storm Water Model.....	74
6	Mine Water Management Implementation.....	78
6.1	Key Water Management Facilities.....	80
6.1.1	Ponds.....	82
6.1.1.1	Lower Dublin South Sediment Control Pond.....	82
6.1.1.2	Events Pond.....	83
6.1.1.3	In-Heap Pond.....	83
6.1.1.4	Supplemental Water Storage Pond.....	83
6.1.1.5	Desired Available Storage.....	83
6.1.2	Ditches.....	84
6.1.3	Mine Water Treatment Plant.....	85
6.1.3.1	Design.....	86
6.1.3.2	Construction and Commissioning.....	87
6.1.3.3	Operations.....	87
6.1.3.4	Starting the MWTP After an Extended Shutdown Period.....	87
6.1.3.5	MWTP Solids Residue.....	87
6.1.3.6	Cyanide Destruction.....	87
6.2	Key Water Management Hydrometric Stations and Transfer Monitoring Within the Mine footprint.....	88
6.3	Water Management Targets and Actions.....	91
6.3.1	LDSP Inflows and Pond Levels 2020-2023.....	91
6.3.1.1	Summer LDSP Targets.....	91
6.3.1.2	Pre-Freshet LDSP Targets.....	92
6.3.1.3	Freshet Readiness.....	95
6.3.2	EP Inflows and Pond Levels.....	96
6.3.3	In-Heap Pond Levels.....	100
6.3.4	Historical Capacities for Pumping and Transferring Water.....	100
6.3.5	Selection of WMP Targets and Actions.....	101
6.4	Other Water Management Structures.....	105
6.4.1	Culverts.....	105
6.4.2	Pipes.....	105

	6.4.3 Evaporators	105
6.5	Key Minesite Infrastructure	106
	6.5.1 Open Pit.....	106
	6.5.2 Heap Leach Facility	106
	6.5.3 Waste Rock Storage Areas	107
6.6	Erosion and Sediment Control Plan Implementation	107
	6.6.1 Erosion and Sediment Control - Current Status	108
	6.6.2 Erosion and Sediment Control - Forward Planning.....	109
6.7	Sanitary Wastewater Management.....	111
6.8	Water Uses	111
6.9	Frozen Material Management	112
6.10	Maintenance and Monitoring Strategies	113
7	Water Distribution.....	114
	7.1 Fresh Water	116
	7.2 Process Water.....	116
	7.3 Potable	116
	7.4 Fire Suppression.....	116
	7.5 Dust Control	117
8	References.....	118

List of Tables

Table 1.2-1:	Mine Schedule Controls on Water Management Strategies	5
Table 2.3-1:	Positions and Responsibility Summary.....	8
Table 2.3-2:	Water Management RACI Matrix.....	11
Table 2.3-3:	Engineers of Record*	13
Table 3.2-1:	Climate Stations at the Eagle Gold Mine.....	16
Table 3.2-2:	Snow Survey Stations at the Eagle Gold Mine.....	16
Table 3.2-3:	Mine (Site) Monthly and Mean Annual Temperatures	18
Table 3.2-4:	Potential Evaporation (PE) Estimates for the Camp Site	19
Table 3.2-5:	Mine Site Monthly Precipitation/Rainfall Data.....	20
Table 3.2-6:	Mine Site Snow Survey Data	22
Table 3.2-7:	Recurrence Interval Estimates of 24-hour Storm Rainfall Depths (mm)	24
Table 3.2-8:	Maximum Monthly 24-hour Rainfall for the Camp Station (mm)	24
Table 3.2-9:	Maximum Monthly 24-hour Rainfall for the Potato Hills Station (mm).....	25
Table 3.4-1:	Eagle Gold Mine Hydrometric Stations.....	28

Table of Contents

Table 3.4-2:	Summary of Monthly Average Discharge (2007-2022), Unit Yield and Runoff for Mine Site.....	28
Table 3.4-3:	Additional Hydrometric Stations Currently Active for the WMP.....	29
Table 3.5-1:	Eagle Pit Year End 2022 Eagle Pit Piezometer Status.....	42
Table 4.1-1:	Design Criteria.....	54
Table 4.2-1:	Temporary Sediment Basin Design Specifications.....	61
Table 5.7-1:	Catchment Areas Used in the Model.....	75
Table 5.7-2:	Flood Volume and Peak Runoff Values Estimated from the Rainfall Runoff Analysis.....	75
Table 6.1-1:	Change in Pond Capacities Due to Sediment Infill Since Construction.....	83
Table 6.1-2:	Desired Available Storage Volume.....	84
Table 6.1-3:	Water Management Ditch Design Specifications.....	84
Table 6.1-4:	Collection Ditch Specifications.....	85
Table 6.2-1:	Minesite Hydrometric Stations.....	88
Table 6.3-1:	Top Ten 24-hour LDSP Non-Freshet Inflows.....	91
Table 6.3-2:	Top Ten 3-day LDSP Non-Freshet Inflows.....	92
Table 6.3-3:	Comparison of Wintertime LDSP Pump-Outs 2021-2023.....	94
Table 6.3-4:	Comparison of LDSP Pond Volume Minimums and Pump-Outs 2020-2023.....	95
Table 6.3-5:	Top 15 3-Day Freshet LDSP Inflows.....	95
Table 6.3-6:	Seasonal Variability of LDSP and HLF-UMV Inflows.....	97
Table 6.3-7:	Comparison of 2020-2023 Annual Production, Water Use and Water Use Rates.....	98
Table 6.3-8:	Comparison of 2020-2023 Monthly Water Use and Water Use Rates.....	98
Table 6.3-9:	Seasonal Variability in Water Sources and Water Use.....	99
Table 6.3-10:	2021-2023 Maximum Daily and 7-Day Pumping Totals for Each Possible Transfer Route.....	101
Table 6.3-11:	Water Management Pond Targets.....	101
Table 6.3-12:	Water Management Actions when Triggers are Reached.....	103
Table 6.4-1:	Culvert Specifications.....	105
Table 7.1-1:	Fresh Water Capacities.....	116

List of Figures

Figure 1.1-1:	Property Location Map.....	3
---------------	----------------------------	---

Figure 1.1-2:	General Arrangement	4
Figure 3.2-1:	Climate Monitoring Stations and Snow Survey Locations.....	17
Figure 3.4-1:	Hydrometric Station Network	31
Figure 4.1-1:	Overview Plan Watershed Areas.....	56
Figure 4.2-1:	Culvert Sections and Details.....	64
Figure 4.2-2:	Erosion Control BMP - Sections and Details - Sheet 1 of 2	65
Figure 4.2-3:	Erosion Control BMP - Sections and Details - Sheet 2 of 2	66
Figure 4.2-4:	Haul Road Typical Cross Sections	66
Figure 4.2-5:	Mine Service Road Typical Cross Sections.....	67
Figure 5.7-1:	Eagle Gold Basin Model	76
Figure 5.7-2:	Lower Dublin South Pond Current Status.....	77
Figure 6.1-1:	Key Water Management Facilities Overview Plan.....	81
Figure 6.2-1:	Key Water Management Facilities and Transfer Monitoring	90
Figure 6.3-1:	2020-2023 Monthly LDSP Inflows	93
Figure 6.3-2:	Seasonal Variability of LDSP Inflows 2020-2023	94
Figure 6.3-3:	2020-2023 Events Pond Levels.....	96
Figure 6.3-4:	Comparison of 2020-2023 HLF-UMV Monthly Transfers to the Events Pond	97
Figure 6.3-5:	Comparison of 2020-2023 Monthly Process Water Use Volumes and Rates.....	99
Figure 6.3-6:	In-Heap Pond Levels 2020-2023	100
Figure 7.1-1:	Mine Site Water Distribution Plan.....	115

List of Appendices

Appendix A	Flocculant Use Plan
Appendix B	As-Built Record Drawings and Reports

List of Acronyms and Abbreviations

% percent
< less than
> greater than
ADR adsorption, desorption and recovery
BC British Columbia
BGC BGC Engineering Ltd.
BMP Best Management Practice
CHP corrugated metal half-pipe
cm centimetre
CN curve number
CWTS constructed wetland treatment system
°C degrees Celsius
DAS Desired Available Storage
EMSAMP Environmental Monitoring, Surveillance and Adaptive Management Plan
EP Events Pond
EQS effluent quality standards
EP WRSA Eagle Pup Waste Rock Storage Area
FMMP Frozen Materials Management Plan
GCL geosynthetic clay liner
ha hectare
hr hour
HLF Heap leach facility
HLF WBM Heap Leach Facility Water Balance Model
HLF UMV Heap Leach Facility Underdrain Monitoring Vault
IDF Intensity-Duration-Frequency
IHP In-Heap Pond
IROSA ice-rich overburden storage area
km kilometres

km ²	square kilometres
L	litres
LDSP	Lower Dublin South Pond
LLDPE	linear low-density polyethylene
m	metres
MAP	mean annual precipitation
masl	metres above sea level
m ²	square metres
m ³	cubic metres
m/s	metres per second
MF	microfiltration
mg/L	milligrams per litre
min	minutes
Mine	Eagle Gold Mine
MIW	mine-influence water
mm	millimetre
MWTP	mine water treatment plan
PE	potential evaporation
PG WRSA	Platinum Gulch Waste Rock Storage Area
pH	potential of hydrogen (measure of acidity)
PLS	pregnant leach solution
PTS	passive treatment systems
RECP	rolled erosion control products
SGWM	Sitewide Numerical Groundwater Model
SWBM	Site Water Balance Model
SWBP	Site Water Balance Program
SWE	snow water equivalent
SWM	Stormwater Model
SWQM	Sitewide Water Quality Model

Table of Contents

WAD CN.....weak acid-dissociable cyanide
WBM water balance model
WPSIMP..... Water, Pond and Solution Inventory Monitoring Program
WQM water quality model
WRSAwaste rock storage area

1 INTRODUCTION

The Eagle Gold Mine (the “Mine”) is located about 85 kilometers (km) from Mayo, Yukon using existing highway and access roads (Figure 1.1-1). The Mine involves open pit mining at a production rate of approximately 10.7 million tonnes per year ore. The open pit is being developed using standard drill and blast technology. Ore is removed from the open pit by haul truck and delivered to the first stage crushing plant (the primary crusher), situated on the north side of the open pit, passed through three crushing stages and then delivered to the heap leach facility (HLF) via conveyor belt. Gold is extracted using heap leaching, and a carbon Adsorption, Desorption, and Recovery (ADR) system over life of mine. Over the life of mine, waste rock is removed from the open pit by haul truck and delivered to one of two waste rock storage areas (WRSA). Waste rock deposition in the Platinum Gulch WRSA (PG WRSA) has been completed and the remaining waste rock encountered during mining will be placed in the Eagle Pup WRSA (EP WRSA).

Constructed water-related infrastructure includes:

- a control pond (the Lower Dublin South Pond or LDSP) – which collects drainage from both Ditch A and Ditch B; the LDSP serves as a retention pond for water that is either transferred to the Heap Leach Facility (HLF) Events Pond, where it is then stored and used for HLF process make-up water, or treated and released;
- Ditch A - which collects drainage from the PG WRSA, a portion of the Open Pit and the temporary stockpile, in addition to other interfluvial areas;
- Ditch B – which collects drainage from the EP WRSA, and Suttles Gulch which drains a portion of the Open Pit, and the three-stage crushing area;
- Ditch C – which is the overflow channel for the LDSP;
- the HLF Events Pond (EP) – which is the overflow pond from the HLF spillway; the EP also functions as a temporary storage pond for HLF make-up water transferred from the LDSP and collects subsurface drainage from the HLF via the HLF underdrain monitoring vault (HLF UMV); and,
- the mine water treatment plant (MWTP) – located downgradient from the LDSP and EP, and which treats water (not needed for process) from the LDSP and the Events Pond (EP) before discharging to Haggart Creek via a pipeline.

Additional water-related infrastructure that may be completed if needed includes an ice-rich overburden storage area (IROSA). The general layout of the mine and water management infrastructure components of the Mine are presented in Figure 1.1-2.

The open pit is located to the south of the Dublin Gulch valley in the headwater areas of Suttles Gulch and Platinum Gulch. Mined rock that does not contain economic ore or cannot be used for construction is placed in the WRSAs.

Non-contact water has been and/or will be diverted, as feasible, around disturbed areas before discharging into receiving waters (i.e., Haggart Creek, Dublin Gulch and Eagle Creek). During closure, infrastructure will be decommissioned, covers will be placed on the WRSAs and the HLF, active water treatment systems will be in place and ultimately phased out as passive treatment systems are established.

1.1 MINE LOCATION AND BACKGROUND

The majority of the Mine site lies within the Dublin Gulch watershed. Dublin Gulch is a second order stream that is a tributary to Haggart Creek which flows to the South McQuesten River. Elevations in the vicinity of the Mine range from 730 meters above sea level (masl) in the Haggart Creek valley to 1,540 masl at the summit of Potato Hills (which forms the eastern boundary of the Dublin Gulch watershed).

Access to the Mine site is from the Silver Trail (Highway 11) onto the existing South McQuesten Road and Haggart Creek Road. Together, the two roads comprise a 45 km road divided by the South McQuesten River.

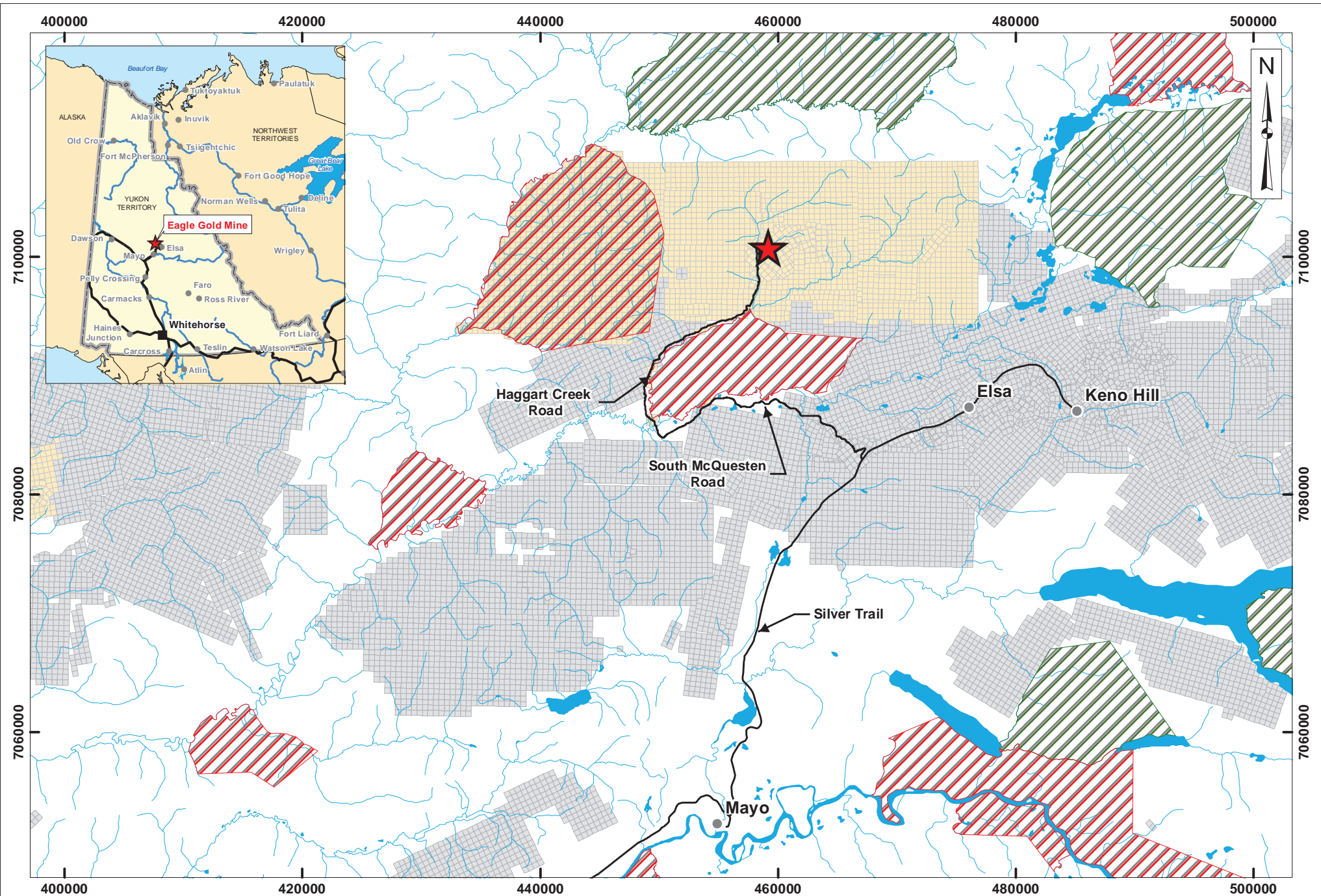

Legend:

	Eagle Gold Mine		Town / Village		Category A Settlement Land
	Victoria Gold Claims		Road		Category B Settlement Land
	Other Claims		Watercourse		

VICTORIA GOLD CORP

0 3 6 12
Kilometres

Projection:	Drawn By:
NAD 83 Zone 8N	HC
Date:	Figure:
2023/03/17	1.1-1

**EAGLE GOLD MINE
YUKON TERRITORY**

Project Location



Legend:	<ul style="list-style-type: none"> — Facility — Built — Watercourse - Perennial - - - Collection Ditch - Main — Not Built - - - Watercourse - Ephemeral - . - . - . Watercourse - Intermittent
---------	---

VICTORIA GOLD CORP

0 125 250 500
Meters

Projection:	Drawn By:
NAD 83 UTM Zone 8	HC
Date:	Figure:
2024/03/30	1.1-2

**EAGLE GOLD MINE
YUKON TERRITORY**

General Arrangement

1.2 MINE SCHEDULE

A summary of the Mine schedule is provided in Table 1.2-1. The schedule is conceptual and dependent upon various operational considerations.

Table 1.2-1: Mine Schedule Controls on Water Management Strategies

Mine Phase	Duration (yrs)	Controls on Water Management Strategies
Phase 1 (completed)	3	Complete ramp-up and Phase 1 of HLF development; contact water managed based on process make-up requirements, through adaptive water management strategies; MWTP constructed and commissioned by end of Phase 1. Waste rock sent primarily to the PG WRSA; begin development of the EP WRSA.
Phase 2	2.5	North-Northeastward expansion of the HLF footprint and continued stacking; active treatment of contact water from the LDSP; waste rock sent primarily to the EP WRSA; progressive reclamation of PG WRSA; development of the PG PTS
Phase 3	2	Eastward expansion of the HLF footprint and continued stacking until the HLF reaches capacity; WRSA sent to EP WRSA; continued active treatment and development of the PG WRSA cover and PG PTS
Phase 4	1.0	Termination of mining and ore production, but continued leaching of the ore stack for gold production; begin reclamation of EP WRSA and begin development of LDSP PTS, managed pumpback of heap drain-down solution; open pit begins to fill
Phase 5	2.0	Termination of gold production and period of rinsing and cyanide destruction; managed pumpback of heap drain-down solution – some heap discharge to treatment; PG PTS discharge to Haggart Creek if criteria are met; open pit still filling
Phase 6	5.0	Controlled drain-down of heap (drain-down solution split into two flows: managed pumpback to heap and proportion sent to active treatment); HLF cover applied in stages; begin conversion of Event Pond into HLF PTS; when flows and concentration criteria are met - change from active treatment to passive treatment of the heap seepage; open pit fills – flow allowed to drain to Haggart Creek (via PTS as necessary)
Phase 7	NA	Uncontrolled drainage of heap – seepage rate will ultimately meet rate of meteoric input; all passive treatment systems in place and meeting objectives and monitoring in effect
Phase 8	NA	Post-closure. Monitoring as required

1.3 DEFINITIONS

The term “sediment-laden water” is used to describe water that originates from disturbed areas (e.g., roads, foundation pads, etc.) and only needs treatment for sedimentation, which is done through the management practices described in this Plan. “Contact water” is used to describe water that will come into contact with the open pit, waste rock storage areas, or the heap leach facility. This type of water may require additional treatment (i.e., at the MWTP or PTS) during operations and/or closure prior to discharge to the environment. Conversely, “non-contact water” is used to describe water that has not come into contact with any Mine facilities.

1.4 SCOPE OF PLAN

This Water Management Plan (the “Plan”) has been developed to proactively manage sediment-laden, contact and non-contact water within the Mine site.

The Plan has several functional components, each developed from specific design basis and criteria, supported by the integration of baseline studies and various water-related modeling exercises, and first-hand experience of managing water on site since 2017 (when construction began).

The Plan describes the capability of the site water management infrastructure to detain, retain, control and convey short duration extreme rainfall events, freshet snowmelt runoff and other runoff generated from rainy periods, groundwater seeps and open pit horizontal drainholes. Water management facilities are designed with two specific operating modes: 1) service conditions, which include day-to-day operations and 2) ultimate limit conditions, which include provisions for safely handling extreme peak runoff events.

The sediment and erosion control section describes the best management practices (BMPs) that have been and will be implemented on site with appropriate flexibility for new control measures to continue to allow the design elements to be field-fit to suit the conditions encountered (i.e., adaptive management approach).

The operations water management section describes water routing and key management facilities built during the construction (e.g., Ditch A and Ditch C, LDSP, and the EP) and operations phase (Ditch B and the MWTP), and in addition to those facilities maintained for use into the operations phase.

Closure and post-closure water management is described in the Reclamation and Closure Plan.

2 WATER MANAGEMENT PLANNING

2.1 OBJECTIVES

The primary objective of this Plan is to protect and conserve water resources (including the water quality, water quantity, and the aquatic ecosystem) from impairment caused by the Mine. Other objectives considered when developing design criteria include the following:

- Protect and prevent surface and ground water resources from potential contamination caused by the activities throughout the Mine.
- Protect infrastructure from damage, maintain safety and minimize financial costs for repair or replacement.
- Maximize water reuse and avoid contaminated water discharges.
- Maximize clean water runoff.
- Prevent the discharge of sediment-laden water to surface water streams.
- Minimize the impact on the receiving environment.
- Encourage stabilization and regrowth of vegetation.

2.2 STRATEGIES

The primary strategies for achieving the objectives listed above include:

- Separating waters of different quality, so that water quality deterioration is minimized. (i.e., diverting non-contact water away from disturbed areas).
- Minimizing the contact between water and potential contaminants, such as chemicals, petroleum products, or waste products.
- Erosion and pollution source control (i.e., minimizing total suspended solid levels in runoff from disturbed areas),
- Capture of contact water so that it can be used for process make-up or treated, as necessary, prior to discharge back into the environment.

Management of non-contact water is best done by directing surface runoff away from disturbed areas. This process can be done by constructing small stable channels, swales, or ponds to capture as much of the surface runoff as possible, or by constructing small obstacles such as berms or other barriers, that will redirect the flow around a specific area.

Management of sediment-laden water is best done by reducing the velocity of water thus allowing sediments to settle. This process can be done by constructing channels with check dams, SCPs, sediment basins, exfiltration ponds, and sediment traps, as well as through the stabilization of disturbed land surfaces, and re-establishment of vegetative cover. Where final slopes are created, indigenous vegetation will be planted.

Management of contact water is best done by capturing water in the LDSP, using this water for various mine operations (e.g., process water, dust control) and/or pumping the water to the MWTP, where it can then be treated, as necessary, prior to discharge back to the environment.

In summary, all water will need to be controlled in such a manner that minimizes erosion in areas disturbed by construction or operational activities and which prevents the release of contact water, which could adversely affect the quality of receiving waters (e.g., Dublin Gulch, Haggart Creek, and Eagle Creek).

2.3 EXECUTION STRATEGY

2.3.1 Roles and Responsibilities

To ensure that the Plan is executed effectively, clearly defined roles and responsibilities for water management design, construction and implementation are critical.

Table 2.3-1 provides details on the key positions within VGC that have responsibilities related to the execution of the Plan.

Table 2.3-1: Positions and Responsibility Summary

Position	Responsibilities and Accountabilities
Chief Operating Officer (COO)	<ul style="list-style-type: none"> ▪ Reports to CEO ▪ Overall accountability for the operation of the Mine ▪ Oversight of resources (human and financial) for the implementation of VGC's commitments and objectives related to production, health and safety, and environment ▪ Oversees on-site environmental and health and safety performance
VP - General Manager of Eagle Gold Mine	<ul style="list-style-type: none"> ▪ Reports to COO ▪ Overall accountability for the operation of the Mine ▪ Responsible for providing oversight for all Mine operations and allocating the necessary resources for the operation, maintenance and management of Mine infrastructure. ▪ Accountable for on-site environmental, health and safety performance during operation
VP Environment	<ul style="list-style-type: none"> ▪ Reports to COO ▪ Monitors and reports on VGC's performance related to environmental policies and objectives ▪ Liaise with regulatory authorities ▪ Monitors compliance with terms and conditions of permits and licences ▪ Reviews and prepares updates for management plans ▪ Supports the management of Mine water management infrastructure by advising operational departments and obtaining the appropriate regulatory approvals as necessary
Environmental Manager	<ul style="list-style-type: none"> ▪ Reports to VP - General Manager of Eagle Gold Mine ▪ Liaises with the senior management, regulators and stakeholders ▪ Ensures effective monitoring and auditing of environmental performance of departments and contractors on site and identifies opportunities for improvement ▪ Monitors compliance with permits, licenses and authorizations ▪ Ensures regulatory environmental monitoring and reporting requirements are met ▪ Reviews and prepares updates for management plans ▪ Oversees environmental studies and monitoring programs ▪ Liaises with Operations managers to prioritise water management planning, infrastructure and initiatives
Administration Manager	<ul style="list-style-type: none"> ▪ Reports to VP - General Manager of Eagle Gold Mine ▪ Accountable for procurement and purchasing, including water management infrastructure for the Mine ▪ Ensure that environmental commitments, policies and objectives are included in all contract documents
Mine Operations Superintendent / Manager, Engineering and Projects	<ul style="list-style-type: none"> ▪ Reports to the VP - General Manager of Eagle Gold Mine ▪ Provides oversight and is accountable for all Mine mining operations, including the operation, construction and maintenance of water and waste management infrastructure at mining areas, stockpiles, WRSAs and along mine roads, including culverts, ditches, and surface water management ponds. ▪ Responsible for implementing identified water management mitigations and initiatives within functional area

Section 2 Water Management Planning

Position	Responsibilities and Accountabilities
Process Operations Manager	<ul style="list-style-type: none"> ▪ Reports to the VP - General Manager of Eagle Gold Mine ▪ Provides oversight and is accountable for all ore crushing and processing operations, including the operation, construction and maintenance of surface water management infrastructure associated with the HLF, including culverts, ditches, and the Events Pond ▪ Responsible for the management of the MWTP ▪ Responsible for implementing identified water management practices and initiatives within functional area
Site Services Manager	<ul style="list-style-type: none"> ▪ Reports to the VP - General Manager of Eagle Gold Mine ▪ Provides oversight and is accountable for all Site Services operations, including the operation, construction and maintenance of water and waste management infrastructure including the LDSP and associated ditches, and release of water from the LDSP ▪ Responsible for managing water in containment areas associated with fuel facilities and hazardous materials/waste storage areas, including landfarm and landfill facilities
General Foremen	<ul style="list-style-type: none"> ▪ Reports to the Manager/Superintendent of respective department ▪ Responsible for providing leadership and direction to the Operations/Process function ▪ Responsible for implementing identified water management practices and initiatives within functional area
Fixed Maintenance Superintendent	<ul style="list-style-type: none"> ▪ Reports to the Process Operations Manager ▪ Provides oversight and is accountable for all fixed equipment maintenance activities ▪ Responsible for managing water in containment areas associated with maintenance equipment areas and any actual maintenance and service work sites
Mobile Maintenance Superintendent	<ul style="list-style-type: none"> ▪ Provides oversight and is accountable for all mobile equipment maintenance activities ▪ Responsible for managing water in containment areas associated with maintenance equipment areas and any actual maintenance and service work sites
Environmental Superintendent	<ul style="list-style-type: none"> ▪ Reports to the Environmental Manager ▪ Overall accountability for environmental staff and performance at site ▪ Coordinates implementation and monitors the performance of the Environmental Management Systems at site ▪ Serves as the liaison for regulatory agents during onsite inspections and visits ▪ Provides ongoing environmental education and environmental awareness training to all employees and contract workers ▪ Prepares investigations and reporting of environmental incidents to regulatory bodies, stakeholders and senior management ▪ Manages environmental studies and monitoring programs ▪ Reviews and prepares updates for management plans ▪ Works directly with site managers and supervisors to prioritise water management planning, infrastructure and initiatives ▪ Advises operational departments on the implementation of the appropriate controls to manage surface water flows and contact water, including the implementation of sedimentation and erosion controls
Environmental Coordinator	<ul style="list-style-type: none"> ▪ Reports to the Environmental Superintendent ▪ Specific accountabilities for environmental monitoring, sampling and reporting as per Mine management plans and regulatory approvals ▪ Provides day to day direction to Environmental and Operations staff onsite in regard to water management ▪ Serves as a liaison for regulatory agents during onsite inspections and visits ▪ Provides ongoing environmental education and environmental awareness training to all employees and contract workers ▪ Monitors and tracks water management infrastructure onsite ▪ Supports updates of management plans ▪ Works with site departments to inspect water management infrastructure
Environmental Technician	<ul style="list-style-type: none"> ▪ Reports to the Environmental Coordinator ▪ Works with operations to inspect water management infrastructure ▪ Responsible for monitoring and sampling activities in conjunction with operations staff as per the Mine's management plans

2.3.2 Responsibility, Accountability, Consultation and Information

To provide clarity with respect to all aspects of the execution of the Plan, a RACI matrix (Table 2.3-2) has been developed to provide staff with a clear graphic representation of those VGC employees that are directly responsible for each aspect of the Plan. The letters in the RACI matrix correspond to the following: R – Responsible, A – Accountable, C – Consulted, I – Informed; the individual denoted as Accountable holds the ultimate accountability for the task and has the ability to veto certain actions that they deem to be imprudent, inapplicable or inappropriate.

Table 2.3-2: Water Management RACI Matrix

MINE TASK	LEADERSHIP			OPERATIONS									
	COO	VP GM	VP Environment	Mine Ops Snr	Manager Engineering & Projects	Process Operations Manager	Site Services Manager	Maintenance Super	Ops General Foremen / Super	Environment Manager	Enviro Super	Enviro Coordinator / Technician	Admin Manager
PLANNING													
Water Management Plan updates as needed	I	I	A	I	C	C	I	N/A	N/A	R	R	I	N/A
Technical Support for Water Management Plan	I	I	A	I	C	C	I	N/A	N/A	R	R	I	N/A
Design of Additional Mine water treatment plant components	A	A	R	N/A	R	R	I	I	N/A	I	I	I	I
IMPLEMENTATION													
KEY WATER MANAGEMENT FACILITIES													
<i>LDSP</i>													
Decision to initiate discharge from LDSP (based on levels and lab results)	C	A	C	N/A	N/A	C	C	N/A	R	C	R	R	N/A
Manage equipment for initiation or cessations of discharge	I	I	I	N/A	N/A	C	A	N/A	R	C	C	R	N/A
Monitoring LDSP water quality discharge as per effluent quality criteria	I	I	C	N/A	N/A	N/A	C	N/A	N/A	A	R	R	N/A
Decision to cease discharge from LDSP	I	A	C	N/A	N/A	N/A	C	N/A	R	C	R	R	N/A
<i>CULVERTS, DITCHES AND PIPES</i>													
Install culverts, ditches and pipes (excluding Open Pit)	I	I	C	N/A	C	N/A	A	N/A	R	C	C	R	I
<i>OPEN PIT</i>													
Manage open pit water and internal water transfers to Ditch A	I	I	C	A	C	C	C	N/A	R	C	C	I	N/A
<i>HLF</i>													
Initiate pumping from LDSP to HLF for process solution (based on water needs)	I	I	I	N/A	N/A	A	C	I	R	I	I	I	N/A
Initiate pumping from Event Pond to HLF for process solution (based on water needs)	I	I	I	N/A	N/A	A	I	I	R	I	I	I	N/A
Initiate pumping from in-Heap Pond to ADR plant (based on in-Heap Pond water levels)	I	I	I	N/A	N/A	A	I	I	R	I	I	I	N/A
<i>MWTP</i>													
Construct Additional Components of the MWTP	I	A	C	C	C	R	C	C	I	C	R	R	R
Commission Additional Components of the MWTP	I	A	C	C	C	R	C	C	I	C	R	I	R
Operate MWTP	I	C	C	N/A	C	A	I	R	R	C	C	I	N/A
EROSION AND SEDIMENT CONTROL PLAN IMPLEMENTATION													
Incorporate BMPs during operations	I	A	C	R	R	R	R	R	R	C	C	C	R
Construct additional sediment basins, exfiltration areas, berms, diversion ditches, rock energy dissipation structures, silt fencing	I	I	I	C	C	N/A	A	N/A	R	C	C	R	N/A
SANITARY WASTEWATER MANAGEMENT													
Management of potable water and sanitary wastewater	I	I	I	N/A	N/A	N/A	A	R	R	C	C	I	N/A
WATER USES													
Mine-wide tracking of water distribution	C	A	C	N/A	C	C	C	N/A	I	C	C	R	N/A
FROZEN MATERIALS MANAGEMENT													
Management of Ice-Rich Overburden	C	A	I	R	I	I	R	N/A	R	C	C	R	N/A
MAINTENANCE AND MONITORING													
Mine-wide environmental sampling and monitoring	I	I	C	I	I	I	I	I	I	A	R	R	I
Open pit facilities	C	A	C	R	C	I	I	R	R	C	I	R	I
LDSP facilities	C	A	C	I	C	C	R	R	R	C	I	R	I
HLF facilities	C	C	C	I	C	A	I	R	R	C	I	R	I

Section 2 Water Management Planning

MINE TASK	LEADERSHIP			OPERATIONS									
	COO	VP GM	VP Environment	Mine Ops Snr	Manager Engineering & Projects	Process Operations Manager	Site Services Manager	Maintenance Super	Ops General Foremen / Super	Environment Manager	Enviro Super	Enviro Coordinator / Technician	Admin Manager
Mine Water Treatment Plant	C	C	C	I	C	A	C	R	R	C	I	R	I
Sediment basins, ditches, pipes, exfiltration areas, culverts, berms, diversion ditches, rock energy dissipation structures, silt fencing	I	A	C	C	C	I	C	I	R	C	R	R	I
REPORTING													
Monthly WUL reporting	I	I	A	C	C	C	C	C	N/A	R	R	R	N/A
Annual Inspections and reporting of key facilities	I	I	A	R	R	R	C	C	N/A	C	N/A	N/A	N/A
Annual reporting of water management strategies, usage, and distribution	I	I	A	C	C	C	C	C	N/A	R	R	R	N/A
Emergency Response Reporting for LDSP discharges exceeding effluent criteria	C	A	C	N/A	N/A	N/A	C	N/A	N/A	C	R	R	N/A

2.3.3 Engineers of Record

Table 2.3-3 provides the Engineers of Record (EoR) for the design, construction and operation for the identified Engineered Structures on the Mine.

Table 2.3-3: Engineers of Record*

Structure	EoR Design	EoR Construction	EoR Operation	Status
Heap Leach Facility	Phase 1A -Troy Meyer Phase 1B - Barry Carlson	Phase 1A - Troy Meyer Phase 1B - Barry Carlson	Barry Carlson	Construction of the following components complete: <ul style="list-style-type: none"> ▪ Embankment ▪ Phase 1 liner system ▪ Phase 1 underdrains ▪ Phase 1 PLS pipe network ▪ Phase 1 barren solution pipe network ▪ Phase 2 liner system ▪ Phase 2 underdrains
Events Pond	Troy Meyer	Troy Meyer	Barry Carlson	Construction Complete. No modifications made nor required since construction completion. EoR "As-Built" information in final review.
Lower Dublin South Pond	Mauricio Herrera	Mauricio Herrera	N/A No alteration made to facility since completion of construction.	Construction complete.
Ditches A, B, C and 90 Day stockpile connection	Mauricio Herrera	Mauricio Herrera	N/A EoR responsible for construction of additional features will be identified in future submission	Construction of the following components complete: <ul style="list-style-type: none"> ▪ Ditch A, Ditch A pipe, and PG sump ▪ Ditch B STN 0+000 to ST0+314 ▪ Ditch C Additional construction will be undertaken when water management infrastructure is required to manage surface runoff and seepage from newly disturbed areas
Waste Rock Storage Areas	Steve Tang	Mike Levy	Mike Levy	Facility development will continue for the life of mine.
Rock Drain – Waste Rock Storage Area	Kevin Jones	Mike Levy Richard Tuohey	Mike Levy	Facility development will continue for the life of mine.
IROSA	Adam Wallace	N/A	N/A	Facility construction has not commenced.
Open Pit	Mike Levy	Richard Tuohey	Mike Levy	Facility development will continue for the life of mine.
MWTP	Sam Billin	Sam Billin and Rob Gutowski	Sam Billin	Facility engineering completed by Linkan Engineering. Construction and Commissioning overseen by JDS.

Eagle Gold Mine
Water Management Plan

Section 2 Water Management Planning

*Troy Meyer - BGC Engineering, Montrose, Colorado (now retired); Barry Carlson – Forte Engineering, Fort Collins, Colorado; Mauricio Herrera – Tetra Tech, Vancouver, BC (now with SRK Consulting, Vancouver, BC); Steve Tang – VGC, Vancouver, BC (now with Skeena Resources, Vancouver, BC); Kevin Jones – Tetra Tech, Edmonton, Alberta (now retired); Adam Wallace – Tetra Tech, Whitehorse, Yukon; Mike Levy – JDS Energy & Mining, Denver, Colorado; Rob Gutowski - JDS Energy & Mining, Vancouver, BC; Sam Billin – Linkan Engineering, Elko, Nevada

3 ENVIRONMENTAL CONDITIONS

Hydrometeorological conditions have been analyzed and summarized for the Mine by Knight Piesold (2012) and Lorax (2017 and 2021) to provide long-term estimates for various meteorological and hydrological parameters. These studies have provided the basis for the development of hydrometeorological inputs used in the design of water management structures prior to their construction, and for evaluating the relative conservatism of these estimates after amassing several years of hydrometeorological data during operations. These evaluations provide data and interpretations to support the continual refinement and update of design characteristics and water balance models for the Mine area and for future design considerations as necessary.

The summary and discussion provided herein includes recent climate and hydrometric data collected for the Mine site up through 2023 (Lorax 2024 a and b)

The long-term estimates provided in Lorax (2021) were based on regional datasets and available site data from 2007 to 2020. Lorax (2021) summarizes, integrates, and analyses data collected at the Mine site as well as regional data from Environment Canada and Yukon Environment. Prior to finalization of water management infrastructure, the design engineers reviewed the most relevant and recent data collected to confirm that the characterization work undertaken remained appropriate for their design as required by the Type A Water Use Licence QZ14-041 (and subsequently QZ14-041-1)

The long-term estimates considered for the design of water management infrastructure are discussed further in Section 6.

3.1 REGIONAL SETTING

The Mine is located within the Boreal Cordillera ecozone, which comprises much of the southern Yukon and a large portion of northern British Columbia, and more specifically within the Yukon Plateau-North ecoregion. The Boreal Cordillera ecozone is broadly characterized by the presence of several mountain ranges that trend in the northwesterly direction and include extensive plateau regions. The plateaus consist of flat or gently rolling upland terrain separated by broad valleys and lowlands.

The climate is characterized by long, cold, dry winters and short, warm, periodically wet summers, with conditions varying according to altitude and aspect. Streamflow in the region is typically highest in May due to melting of the winter snowpack. Annual peak instantaneous flows commonly occur in this freshet period on larger rivers, but on smaller streams they may also occur in summer or early autumn due to intense rain or rain on snow events. Flows decrease throughout the winter and minimum flows typically occur in late winter and early spring prior to freshet (March or April).

3.2 CLIMATE

3.2.1 Mine Site

The information on the Mine climate stations and snow survey stations is presented in Table 3.2-1 and Table 3.2-2, and the locations are shown in Figure 3.2-1. Climatic parameters are measured at the Mine site by two weather stations. The Potato Hills station is situated near the eastern basin divide (1,420 m). The station installed in August 2007 used an ONSET Hobo datalogger that was replaced with a Campbell Scientific CR1000X datalogger in 2020. The second station was originally installed with a Campbell Scientific CR800 datalogger near the camp at 823 m in August 2009, and subsequently moved to its current location in September 2010 at 782 m

Section 3 Environmental Conditions

to accommodate the construction of new camp facilities. Both stations measure temperature, rainfall, wind speed and direction, relative humidity, barometric pressure and solar radiation at 15-minute intervals. The Camp station is also equipped with a snow sensor that records continuous changes in snow depth. All-season precipitation gauges were installed to replace the rainfall only gauges at both stations in 2020.

During 2021, an additional climate station was installed on the 1370 bench of the PG WRSA, as part of the reclamation research program on covers. This station is installed with a net radiometer, a snow depth sensor and a tipping bucket rain gauge.

Initially, snow surveys were collected only at three stations (Camp, Potato Hills and Ann Gulch). Once Mine operations commenced, the Ann Gulch station was replaced by additional stations in the HLF area and the 1370 bench of the PG WRSA was added.

Table 3.2-1: Climate Stations at the Eagle Gold Mine







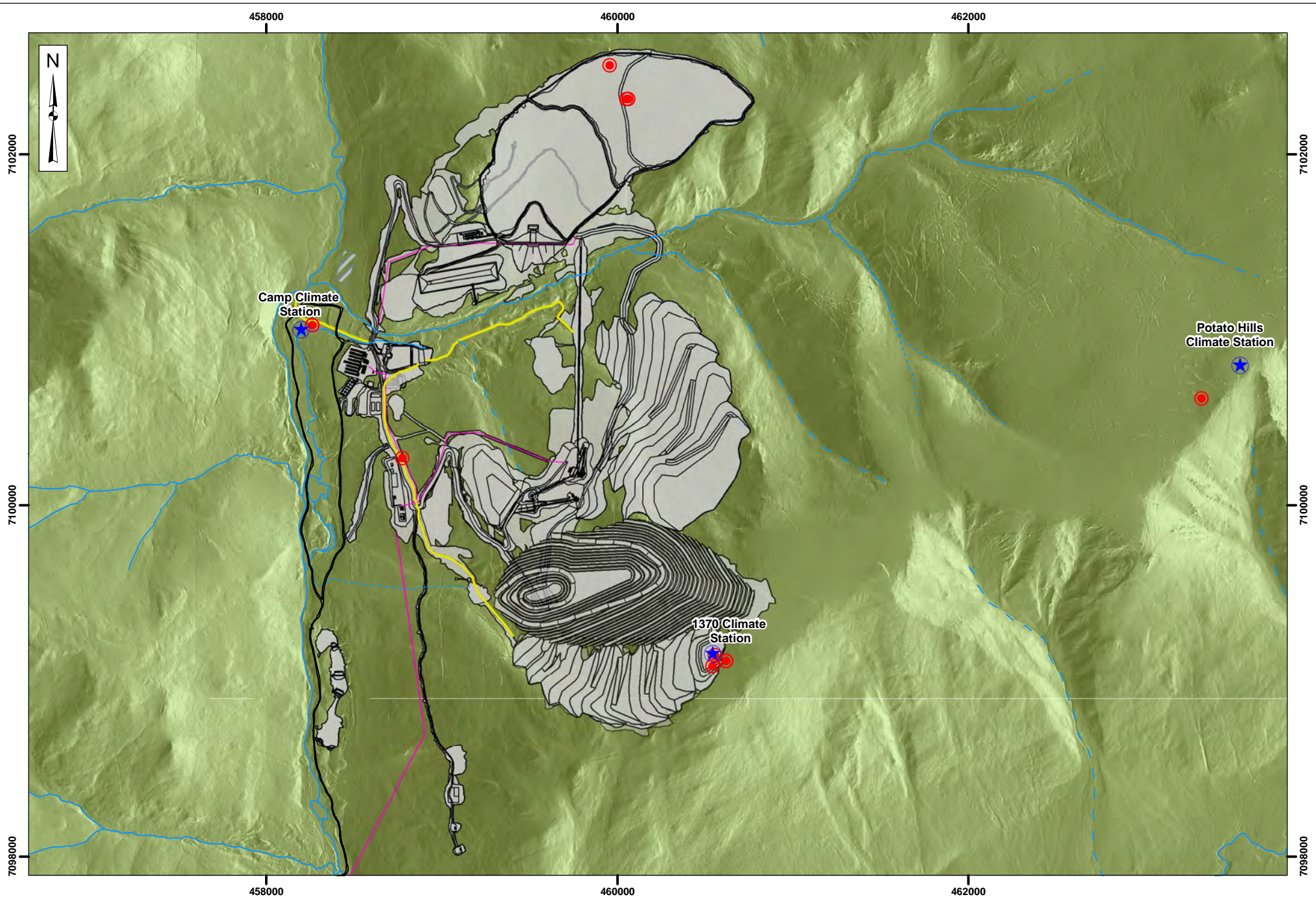

Station	Elevation (m asl)	UTM E	UTM N	Record Period
Camp Station	782	458,164	7,101,036	2009-present
Potato Hills Station	1,420	463,544	7,100,833	2007-present
PG WRSA 1370 Bench	1,370	7,099,188	460,581	2021 - Present

Table 3.2-2: Snow Survey Stations at the Eagle Gold Mine

Station	Elevation (m asl)	UTM E	UTM N	Record Period
Camp	782	458,164	7,101,036	2009-present
Ann Gulch	875	458,945	7,101,185	2012-2017
Stewart (Snow Survey #2)	995	460,570	7,101,490	Mar 2012 only
Potato Hills	1,420	463,290	7,100,568	2009-present
HLF Station	1,078	7,102,319	459,859	2019-2022
PG WRSA 1370 Bench	1,370	7,099,188	460,581	2021 - Present
HLF 3b (Bench and Slope)	1,066	7,102,063	459,295	2021 only
HLF 4b (Bench and Slope)	1,049	7,102,212	459,602	2021 only
HLF 5b (Bench and Slope)	1,048	7,102,207	459,580	2021 only
HLF1b	1,072	7,102,344	459,821	2022 – present
HLF1b-N	1,098	7,102,509	459,960	2022 – present
HLF1b-NW	1,056	7,102,094	459,315	2022 – present
HLF1b-NE	1,118	7,102,129	460,087	2022 - present



Legend:

-  Climate Stations
-  Snow Survey
-  Facility
-  Site Power
-  Watercourse - Perennial
-  Watercourse - Ephemeral
-  Watercourse - Intermittent
-  Reserved Area
-  Major Ditch



Projection:

NAD 83 UTM
Zone 8

Date:

2023-12-29

Drawn By:

LM

Figure:

3.2-1

**EAGLE GOLD PROJECT
YUKON TERRITORY**

**Climate Monitoring Stations
& Snow Survey Locations**

3.2.2 Temperature

Air temperatures at the Mine site are consistent with those throughout the Yukon interior. As indicated in Table 3.2-3 below, mean annual air temperature at site since 2009 is -3.4°C at the Camp station (782 m) and since 2007 -3.7 °C at the Potato Hills station (1,420 m) over their respective periods of record. At the Camp station, monthly average temperature ranges from -19.7°C in December to 13.7°C in July, and -15.4°C to 11.4°C at the Potato Hills station, for the same months. The minimum (maximum) recorded daily average temperatures were -43.8°C (22.0°C) and -36.6°C (22.9°C) at the Camp and Potato Hills stations, respectively. The minimum (maximum) recorded 15-minute temperatures were -46.4°C (31.6°C) and -37.6°C (31.7°C) at the Camp and Potato Hills stations, respectively. For the climate station installed on the 1370 bench of the PG WRSA, air temperature recorded during the 2023 monitoring period ranged from a low of -34.7°C in February to a high of 26.6°C in July.

The monthly mean temperatures signatures for both long term climate stations are shown in Table 3.2-3, and the pattern is consistent with the larger regional picture. During the months of March to October inclusive, the standard lapse rate applies, with temperatures decreasing with rising elevation, and are approximately 3°C cooler at the upper station, on average. However, during the winter months of November to February, temperature inversions are common at the Mine site as per the broader region, with temperatures roughly 2.5°C cooler on average in the valley bottom than at the height of land.

Table 3.2-3: Mine (Site) Monthly and Mean Annual Temperatures

Station	Temperature (°C)												Annual
	Jan	Feb	Mar	Apr	May	Jun	Jul	Aug	Sep	Oct	Nov	Dec	
Camp	-19.2	-18.8	-12.2	-2.2	7.2	12.5	13.7	10.8	4.6	-3.9	-16.6	-19.7	-3.4
Potato Hills	-15.1	-14.4	-12.0	-4.9	4.5	9.9	11.4	8.6	2.3	-5.7	-13.3	-15.4	-3.7

Source: Lorax (2024a)

3.2.3 Potential Evaporation

As described in Lorax (2021) 15-minute potential evaporation rates were computed for the Camp station using available climate and the Ref-ET calculator - a compiled, standalone computer program that calculates reference evapotranspiration (ASCE 2005). For the period of available record (Jan 2013 to Dec 2023 for the purposes of PE calculation), a 15-minute climate input file was prepared for the Eagle Gold Site. The input variables required by Ref-ET are: maximum air temperature, minimum air temperature, relative humidity, incoming solar radiation, atmospheric pressure and wind speed.

From the assembled climate inputs, Ref-ET returned potential evaporation (PE) computations for an array of evaporation models (e.g., Penman-Monteith model, Priestley- Taylor formulation), which were aggregated to daily time-step. Presented in Table 3.2-4 (monthly tabulations) are resulting outputs from Ref-ET for months March to October.

May to end-September PE estimates for the Camp station are also reported in Table 3.2-4 and are estimated to range from 267-448 mm over this period. In terms of monthly magnitudes of PE, highest monthly rates of PE are expected in May, June, July and August of each year.

Table 3.2-4: Potential Evaporation (PE) Estimates for the Camp Site

Period	Method	Potential Evaporation (mm)												Average (2012-2023)
		2012	2013	2014	2015	2016	2017	2018	2019	2020	2021	2022	2023	
Mar	PM	-	17	21	17	24	18	20	24	17	10	13	12	18
	P-T	-	16	19	16	16	13	25	19	19	12	15	10	16
Apr	PM	-	40	47	47	57	56	51	50	59	53	50	36	50
	P-T	-	40	46	46	48	50	59	47	70	65	61	39	52
May	PM	-	78	91	113	106	97	78	96	76	82	94	78	90
	P-T	-	82	85	108	86	80	83	92	89	103	113	87	92
June	PM	-	114	98	97	126	---	94	113	95	137	133	97	110
	P-T	-	116	96	97	109	---	99	109	116	162	158	109	117
July	PM	87	102	91	80	91	---	108	106	108	120	102	111	101
	P-T	93	102	90	86	86	---	113	107	130	147	125	122	109
August	PM	69	74	55	61	79	83	60	69	75	65	70	68	69
	P-T	70	73	56	63	67	68	67	65	90	85	89	74	72
Sep	PM	36	30	33	27	45	34	44	34	32	24	25	23	32
	P-T	26	24	28	23	30	25	49	30	38	32	31	25	30
Oct	PM	6	3	10	10	12	5	14	4	7	1	1	1	6
	P-T	4	3	4	5	5	4	17	4	6	2	3	1	5
Total (Mar-Oct)	PM	-	461	441	455	541	---	470	496	469	493	488	425	475
	P-T	-	453	419	440	447	---	511	473	558	608	596	466	493
Total (May-Sep)	PM	-	397	367	378	448	---	384	418	386	428	424	376	402
	P-T	-	397	354	378	378	---	410	403	463	529	517	417	420

Notes: PM and P-T Indicate potential evaporation (PE) estimates based on Penman–Monteith and Priestley–Taylor approaches respectively. 2. PE Estimates computed using Eagle camp/lower 15-min climate data (I.E, air, temperature, relative humidity, wind speed, precipitation solar radiation, atmospheric pressure) and Ref-Et software.

3.2.4 Precipitation

Regionally, mean annual precipitation (MAP) varies appreciably with elevation. For example, MAP ranges from 324 mm at the Mayo A station (504 m; situated approximately 50 km to the south of the Mine to 572 mm at the Keno Hill station (1,473 m; ~30 km southeast of the Mine). An inspection of available data from regional climate stations indicates both precipitation phases exhibit increases with elevation, with the regional gradients averaging 5%/100 m of elevation gain for rainfall, 11%/100 m for snowfall, and an average MAP gradient of 7%/100 m (Lorax, 2021). On an annual basis, total precipitation in the region is comprised of roughly 60% rainfall and 40% snowfall,

Section 3 Environmental Conditions

noting proportions vary to some degree from station to station, but notably by elevation. Across the Yukon the proportion of annual precipitation falling as snow increases with elevation, resulting in a reversal of the rain/snow proportions (for example for Potato Hills when compared to Camp). Further, for the component of annual precipitation realized as rainfall – roughly half of annual rainfall could be expected in June and July at the Mine.

For the site and prior to June 2020, precipitation data were collected Mine using tipping bucket rain gauges, which were not adapted to measure snowfall. Since June 2020, all-weather precipitation gauges (Geonor weighing cell gauges) have been deployed at both stations. Therefore, the precipitation data presented in Table 3.2-5 prior to June 2020 is for rainfall only, collected between the months of March and October, inclusive. Generally, precipitation falls as snow from November through March, with precipitation falling as a mix of rain and snow in April and October. Rainfall data prior to June 2020 for March are included in the table below, where the temperature record indicates that precipitation would have fallen as rain (i.e., daily average air temperature was above zero).

The data in Table 3.2-5 indicate that mean monthly rainfall is greatest in July at both climate stations (54.8 mm at Camp and 60.1 mm at PH).

Cumulative April to September 2023 precipitation at both Potato Hills (268 mm) and Camp (193 mm) stations closely resembled the respective period of record average (270 mm and 205 mm, respectively).

Summer (July to September) precipitation was markedly below average at both locations. Conversely, October precipitation was substantially above the period of record average. Annual precipitation at both Potato Hills (457 mm) and Camp (386 mm) stations closely resembled the 2020-2023 average (470 mm and 424 mm, respectively).

Notably, total annual precipitation was 656.0 mm at the Camp station, while it was lower at the Potato Hills station (427.2 mm), which is the inverse of the typical precipitation distribution with elevation (i.e., increased precipitation at higher elevations). If this divergence is due to natural variability (and not operational or instrument error), it is likely driven primarily by the rainfall events recorded in late-July through mid-September that are suggestive of convective rainfall events that were more intense at lower elevations in 2022. The precipitation sensors at both stations will continue to be checked by Campbell Scientific technicians on an annual basis to mitigate the potential for erroneous data.

Table 3.2-5: Mine Site Monthly Precipitation/Rainfall Data

Climate Station	Elevation (masl)	Rainfall (mm)															
		Year	Jan	Feb	Mar	Apr	May	Jun	Jul	Aug	Sep	Oct	Nov	Dec	Annual	Apr-Sep	
Camp Station	782	2009	-	-	-	-	-	-	-	-	-	35.0	8.0	S	S	-	
		2010	S	S	5.0	9.0	20.0	62.0	34.0	28.0	25.0	12.0	S	S	195.0	178.0	
		2011	S	S	11.0	10.0	16.0	31.0	75.0	44.0	40.0	9.0	S	S	236.0	216.0	
		2012	S	S	13.0	1.0	22.0	18.0	74.6	29.8	24.0	4.8	S	S	187.2	169.4	
		2013	S	S	8.6	10.4	34.6	25.6	28.4	35.2	58.6	25.2	S	S	226.6	192.8	
		2014	S	S	5.4	8.8	9.2	52.8	43.2	70.4	28.8	23.2	S	S	241.8	213.2	
		2015	S	S	20.8	13.0	8.2	28.8	64.0	62.0	38.6	13.4	S	S	248.8	214.6	
		2016	S	S	6.2	4.4	14.0	32.6	55.0	31.0	25.6	2.6	S	S	171.4	162.6	

Section 3 Environmental Conditions

Climate Station	Elevation (masl)	Rainfall (mm)															
		Year	Jan	Feb	Mar	Apr	May	Jun	Jul	Aug	Sep	Oct	Nov	Dec	Annual	Apr-Sep	
		2017	S	S	S	2.2	24.4	M	M	12.8	20.4	6.0	S	S	-	-	
		2018	S	S	12.0	1.4	63.2	49.4	1.6	34.4	4.6	12.4	S	S	179.0	154.6	
		2019	M	M	M	M	M	M	M	M	M	M	M	M	-	-	
		2020 ⁵	M	M	M	M	M	92.5	99.5	52.7	54.8	36.1	73.2	18.0	-	-	
		2021 ⁵	15.9	14.2	59.0	7.6	48.7	23.5	88.4	91.5	63.6	34.8	21.2	24.6	493.0	323.2	
		2022 ⁵	20.7	27.0	16.9	4.3	12.3	37.7	62.1	72.5	52.0	37.8	16.5	33.5	393.2	240.8	
			23.3	15.2	12.0	21.8	56.4	37.3	32.3	22.1	23.2	82.6	19.7	39.9	385.8	193.1	
		All Years	Mean	S	S	15.4	7.8	27.4	40.9	54.8	45.1	35.3	22.0	32.7	29.0	424.0	205.3
			Max	S	S	59.0	21.8	63.2	92.5	99.5	91.5	63.6	82.6	73.2	39.9	493.0	323.2
			Min	S	S	5.0	1.0	8.2	18.0	1.6	12.8	4.6	2.6	16.5	18.0	385.8	154.6
Potato Hills Station	1420	2007	-	-	-	-	-	-	-	24.0	100.8	2.0	S	S	-	-	
		2008	S	S	3.4	4.8	58.4	52.0	201.2	130.0	11.2	1.2	S	S	462.2	457.6	
		2009	S	S	S	3.0	-	50.8	12.6	75.4	44.4	1.2	S	S	-	-	
		2010	S	S	1.0	6.2	16.4	77.2	45.8	39.4	4.2	5.4	S	S	195.6	189.2	
		2011	S	S	0.2	7.2	21.2	38.0	92.8	83.8	34.4	0.4	S	S	278.0	277.4	
		2012	S	S	S	0.6	9.6	24.2	64.8	37.8	21.0	4.6	S	S	162.6	158.0	
		2013	S	S	2.2	0.2	29.6	33.2	18.0	18.2	63.8	10.0	S	S	175.2	163.0	
		2014	S	S	S	M	M	M	M	M	M	M	S	S	-	-	
		2015	S	S	M	M	M	M	M	48.5	27.1	10.0	S	S	-	-	
		2016	S	S	D	D	14.5	23.0	38.3	42.6	24.6	0.6	S	S	-	-	
		2017	S	S	D	D	16.2	25.8	46.3	21.8	53.0	6.1	S	S	-	-	
		2018	S	S	D	D	D	46.5	13.5	77.0	4.0	3.8	S	S	-	-	
		2019	S	S	D	D	D	D	18.5	D	D	D	S	S	-	-	
		2020 ⁵	S	S	D	D	D	101.2	103.5	68.5	63.7	44.2	18.3	19.0	-	-	
		2021 ⁵	14.2	21.0	58.7	10.9	60.3	29.8	68.2	112.3	66.4	43.5	15.6	25.1	526.1	347.9	
		2022 ⁵	7.8	21.3	12.7	6.7	25.8	35.8	86.8	75.2	64.8	59.1	17.7	13.4	427.2	295.3	
		2022 ⁵	4.6	0.4	40.1	35.9	67.4	54.0	31.0	46.9	32.4	84.6	22.1	38.1	457.4	267.5	
		All Years	Mean	S	S	13.0	4.9	28.0	44.8	62.3	61.0	41.7	13.7	17.2	19.2	318.1	269.8
Max	S		S	58.7	10.9	60.3	101.2	201.2	130.0	100.8	59.1	18.3	25.1	526.1	457.6		
Min	S		S	0.2	0.2	9.6	23.0	12.6	18.2	4.0	0.4	15.6	13.4	162.6	158.0		

Notes:

- Prior to June 2020, winter precipitation data (October through April in many years) are unreliable due to the majority falling as snow. The months where no rainfall was recorded due to freezing conditions are denoted by an 'S'.
- Prior to June 2020, data for the month of October are in italics, as rainfall was not measured for the entire month.
- 'M' denotes data missing due to a sensor malfunction.
- In August 2015, the primary rain gauge at the Potato Hills Station was replaced by a standalone tipping bucket rain gauge. The replacement gauge was deployed each spring (i.e., in April or May) then decommissioned in the autumn (October). Missing data at Potato Hills Station denoted by 'D' indicate time periods during which the standalone tipping bucket rain gauge was not deployed.
- All-weather precipitation gauges were installed in June 2020 at both stations.

3.2.5 Snow Accumulation and Snowmelt

From 2009 to 2019, snow data were collected at three snow courses at the Mine site; since then additional stations were added in the HLF area as part of the program to help estimate snowmelt within the HLF catchment. The annual maximum snow water equivalent (SWE) value generally occurs in late-March or early-April at the Mine site. Field measurements from site show that snow density is generally lower earlier in the season, corresponding to colder temperatures, but increases through winter as the snowpack deepens, weathers and as snow melt progresses.

Mine site snow survey data is summarized in Table 3.2-6 for period of record 2009 to 2023. Annual maximum SWE values range from 93 mm to 199 mm at the Camp snow course, 98 mm to 117 mm at the Ann Gulch/HLF snow course, and vary from 190 mm to 431 mm at the Potato Hills snow course.

The Potato Hills snow survey was conducted in the immediate vicinity of the weather station from 2009 to 2011. However, due to the exposed location, snow redistribution resulted in variable measurements, and therefore the survey was moved to its current and more representative location in 2012, several hundred meters to the south-east (Figure 3.2-1). Note that high snowpacks did not allow access to the Potato Hills snow course in March 2012, and therefore the survey was conducted at Stewart Gulch (Snow Survey #2; Figure 3.2-1).

Table 3.2-6: Mine Site Snow Survey Data

Year	Camp Station				Ann Gulch (Snow Survey #2)				Potato Hills Station			
	Survey Date	Depth (cm)	SWE (mm)	Density (%)	Survey Date	Depth (cm)	SWE (mm)	Density (%)	Survey Date	Depth (cm)	SWE (mm)	Density (%)
2009	2009-04-21	69	112	16%	-	-	-	-	2009-04-21	126	410	33%
2010	2010-03-31	50	99	20%	-	-	-	-	2010-03-31	103	278	27%
	2010-04-21	69	112	16%	-	-	-	-	2010-04-21	126	405	32%
2011	2011-03-28	55	93	17%	-	-	-	-	2011-03-28	105	251	24%
2012	2012-03-20	78	161	21%	-	-	-	-	2012-03-20 ¹	99	237	24%
	2012-04-20	56	79	14%	-	-	-	-	2012-04-22	117	262	22%
2013	-	-	-	-	2013-02-20	70	97	14%	2013-02-28	96	185	19%
	2013-03-02	61	108	18%	2013-03-02	67	115	17%	-	-	-	-
	2013-04-02	59	108	18%	2013-04-02	62	117	19%	2013-04-03	90	190	21%
					2013-04-16	62	85	14%	-	-	-	-
	2013-05-05	58	106	18%	2013-05-03	58	105	18%	2013-05-05	117	167	14%
2014	2014-03-12	57	126	22%	2014-03-12	51	94	18%	2014-03-11	98	276	28%
	2014-04-02	55	100	18%	2014-04-02	46	98	21%	2014-04-02	96	275	29%
	-	-	-	-	-	-	-	-	2014-05-08	70	258	37%
2016	2016-03-02	53	118	22%	2016-03-02	53	117	22%	2016-03-02	95	214	22%
	2016-04-09	38	140	37%	2016-04-09	22	115	52%	2016-04-10	107	257	24%
	-	-	-	-	-	-	-	-	2016-05-03	95	226	24%
2017	2017-03-17	51	89	17%	2017-03-17	50	100	20%	2017-03-17	84	206	25%
	2017-04-13	46	117	25%	2017-04-13	30	82	27%	2017-04-13	98	244	25%
	2017-05-04	7	28	40%	2017-05-04	0	0	NA	2017-05-03	89	236	27%
2018	2018-02-28	53	100	19%	-	-	-	-	2018-02-28	85	203	24%
	2018-04-04	54	109	20%	-	-	-	-	2018-04-04	91	219	24%

Year	Camp Station				Ann Gulch (Snow Survey #2)				Potato Hills Station			
	Survey Date	Depth (cm)	SWE (mm)	Density (%)	Survey Date	Depth (cm)	SWE (mm)	Density (%)	Survey Date	Depth (cm)	SWE (mm)	Density (%)
	2018-05-16	0	0	0%	-	-	-	-	2018-05-16	81	226	28%
					HLF Station (1,078 m)							
2019	2019-03-02	48.3	94	20%	2019-03-02	56.2	119	21%	2019-03-02	78.7	205	26%
	2019-04-01	25.3	72	31%	2019-04-02	37.2	93	25%	2019-04-01	79.3	171	22%
	2019-04-30	0.0	0	-	2019-04-30	31.7	71	18%	2019-04-30	91.0	200	22%
	2019-05-16	0.0	0	-	-	-	-	-	2019-05-16	48.3	111	23%
	2019-06-01	0.0	0	-	-	-	-	-	2019-06-01	0.0	0	-
2020	2020-03-07	89.8	157	18%	2020-03-07	108.7	229	21%	2020-03-13	188.5	431	23%
	2020-04-05	93.9	199	22%	2020-04-10	108.1	262	24%	2020-04-10	140.5	297	21%
	2020-05-02	40.1	142	35%	2020-05-02	50.3	176	35%	2020-05-02	130.3	384	29%
2021	2021-01-15	51.2	74	15%	-	-	-	-	-	-	-	-
	2021-01-30	50.3	77	15%	-	-	-	-	2021-02-03	92.6	216	23%
	2021-02-26	63.1	108	17%	2021-02-26	75.3	140	19%	2021-02-28	100.1	237	24%
	2021-03-30	62.3	113	18%	2021-03-30	78.1	116	15%	2021-03-29	108.9	168	15%
	2021-04-28	38.0	95	26%	-	-	-	-	2021-04-28	95.6	230	24%
	-	-	-	-	-	-	-	-	2021-06-01	16.4	70	32%
2022	2022-01-29	66.8	130	19%	2022-01-29	38.3	66	18%	2022-01-30	128.7	251	20%
	2022-02-27	77.1	157	20%	2022-02-27	39.0	68	18%	2022-02-28	134.6	328	24%
	2022-03-28	74.6	164	22%	2022-03-28	48.1	113	24%	2022-03-26	148.2	422	29%
	2022-04-27	55.1	145	26%	2022-04-27	23.7	78	42%	2022-05-02	137.7	425	31%
2023	2023-01-29	55.2	113	21%	2023-01-29	49.4	99	20%	2023-02-02	93.8	151	16%
	2023-02-25	62.5	124	20%	2023-02-25	61.5	112	18%	2023-02-28	99.6	230	23%
	2023-03-27	66.0	152	23%	2023-03-27	65.0	151	23%	2023-03-28	107.3	271	25%
	2023-04-29	54.1	160	30%	2023-04-29	51.8	267	33%	2023-04-28	124.8	341	27%
	-	-	-	-	-	-	-	-	2023-05-25	23.3	93	40%

Notes:

1. Snow survey data for Potato Hills collected on 2012-03-20 is from Stewart Gulch survey (Snow Survey #2) at 995 masl.
2. No snow surveys were conducted at site in 2015.
3. The HLF Station replaced the Ann Gulch Station in 2019

3.2.6 Extreme Rainfall

The derivation of extreme rainfall/snowmelt events have been important input criteria for the design of water management infrastructure to ensure that extreme events can be adequately managed. Estimates of the 24-hour rainfall for various return periods were developed in 2012 (Knight Piesold, 2012) and then revised again in 2017 (Lorax 2017) to support the design of key Mine infrastructure (Table 3.2-7). The specific infrastructure designs informed by these estimates (LDSP, Ditch A, Ditch B, Ditch C, culverts, etc.) have all been constructed.

Estimates of the 24-hour rainfall for various return periods were computed in three ways. The first method used the rainfall Intensity-Duration-Frequency (IDF) curves published by Environment Canada for the Mayo A climate station, and the second method used the longer daily rainfall record from the Mayo A station. For reference, the values determined by the two methods were compared to an older and highly conservative method using a

Section 3 Environmental Conditions

frequency factor approach, as presented in the Rainfall Frequency Atlas for Canada (Hogg and Carr, 1985). The values derived from the scaled Mayo A daily data (highlighted in grey) reported in Table 3.2-7 have been recommended for use in further engineering design.

Table 3.2-7: Recurrence Interval Estimates of 24-hour Storm Rainfall Depths (mm)

Exceedance Probability	Return Period	Mayo A	Camp		Mine			Potato Hills	
		504 m	782 m		1125 m			1420 m	
		IDF	Daily ¹	IDF ²	Daily ¹	IDF ²	ARFA ³	Daily ¹	IDF ²
0.5	1:2 (median)	18	23	20	26	23	31	29	26
0.2	1:5	22	29	25	33	28	41	37	32
0.1	1:10	25	33	28	38	32	49	42	36
0.04	1:25	29	38	32	44	37	58	49	42
0.02	1:50	31	42	35	48	40	65	54	44
0.01	1:100	34	46	38	53	43	72	59	49
0.005	1:200	39 ⁴	50	44	57	50	78	64	56
0.001	1:1000	43 ⁴	59	48	67	55	94	75	62
PMP	PMP	--	--	--	--	--	256	--	--

Source: Lorax (2017a)

Notes:

- 1 Based on the Mayo A annual maximum daily rainfall, multiplied by 1.18, and scaled by elevation.
- 2 Based on the Mayo A 24-hour IDF curve estimates and scaled by elevation.
- 3 Based on the Adjusted Rainfall Frequency Atlas method (Knight Piésold 2013).
- 4 IDF curve values not provided for these recurrence intervals – values in table based on extrapolation.

An additional nine years of climate data have been collected at the Mine site since the 2013 rainfall estimates were first developed. Daily rainfall totals for the record periods used in the updated analysis were converted to 24-hour totals following Herschfield (1961) in Lorax (2021), and monthly maximums were then calculated for the Camp (Table 3.2-8) and Potato Hills (Table 3.2-9) locations. Review of the 2023 precipitation data collected at the Camp station indicated that these data were biased high relative to the Potato Hills precipitation data, which deviates from the well-developed understanding that precipitation increases with elevation at the Mine. Campbell Scientific identified the root cause as a calibration factor error dating back to the factory testing of the Geonor gauge. The Camp station precipitation data collected since March 2020 were adjusted to remove this error; however, reanalysis of the maximum monthly 24-hour rainfall depths for the camp station have not been completed at the effective date of the version of the Plan.

Table 3.2-8: Maximum Monthly 24-hour Rainfall for the Camp Station (mm)

Month	2009	2010	2011	2012	2013	2014	2015	2016	2017	2018	2019	Max
May	--	9.6	5.6	7.6	6.6	4.0	3.8	7.6	9.2	10.4	NA	10.4
Jun	--	15.2	8.4	6.6	4.6	14.0	7.2	11.0	5.0	11.0	NA	15.2
Jul	--	8.0	17.8	22.0	9.4	11.2	14.0	21.2	11.6	3.2	NA	22.0
Aug	11.2	15.4	14.0	14.0	19.8	13.2	16.8	12.0	3.2	13.0	NA	19.8
Sep	8.6	8.4	8.2	8.8	15.8	8.6	15.4	10.6	15.6	1.4	NA	15.8
Max	11.2	15.4	17.8	22.0	19.8	14.0	16.8	21.2	15.6	13.0	NA	22.0

Table 3.2-9: Maximum Monthly 24-hour Rainfall for the Potato Hills Station (mm)

Month	2007	2008	2009	2010	2011	2012	2013	2014	2015	2016	2017	2018	2019	2020*	2021*	2022*	Max
May	--	14.8	0.0	7.8	6.2	2.4	7.0	NA	NA	6.1	5.0	6.6	NA	NA	10.1	5.5	14.8
Jun	--	16.4	14.4	20.4	13.4	7.2	8.0	NA	NA	5.4	11.4	6.3	NA	36.1	12.9	8.1	36.1
Jul	--	27.0	5.0	16.2	17.2	17.0	3.6	NA	NA	7.3	11.0	5.4	NA	19.2	13.6	33.6	33.6
Aug	14.2	38.2	12.6	20.2	19.8	16.2	6.2	NA	13.1	13.6	7.0	21.1	NA	15.9	34.2	13.1	38.2
Sep	35.8	4.0	9.2	1.8	12.8	6.8	10.0	NA	9.5	6.7	14.2	1.2	NA	14.2	13.0	9.6	35.8
Max	35.8	38.2	14.4	20.4	19.8	17.0	10.0	NA	13.1	13.6	14.2	21.1	NA	36.1	34.2	33.6	38.2

* New all weather Geonor T-200B series precipitation gauge installed in 2020 replaced Hobo rainfall tipping bucket gauge

Source: Lorax (2022, Potato Hills Station Data for 2022)

3.2.7 Snowmelt

Continuous snow depth data have been recorded at the Camp station since 2012 and are summarized in Figure 3.2-2 (Lorax 2024a). The upper panel of Figure 3.2-2 shows the evolution of the snowpack for the 2012 to 2023 time-period, with pack depth showing initial and appreciable accumulation through the months of November and December, typically reaching maximum depth by mid-March each year. These data then show that snowpack depth remains deep and relatively stable to April. The lower panel of Figure 3.2-2 illustrates the timing and rate of snowpack loss for the Camp climate station. While variable from year to year, these data show snowpack losses typically begin in earnest by mid- to late-April, with the duration of melt lasting 15-20 days.

Importantly, while the snowmelt process at the Camp Station is documented it has been observed that the onset of snowmelt at higher elevations (PH) and/or north-facing slopes is typically 2-4 weeks later, and is even earlier for the south-facing slopes of the HLF. Thus, the HLF can be devoid of snow by early April, while there could still be substantial snow at Potato Hills by the end of May. This factor is evident when characterizing the timing and duration of freshet runoff and peak flows for the LDSP, Dublin Gulch and Haggart Creek, which all experience peak freshet runoffs at different times (generally LDSP peak occurs before Dublin Gulch which in turn occurs before Haggart Creek).

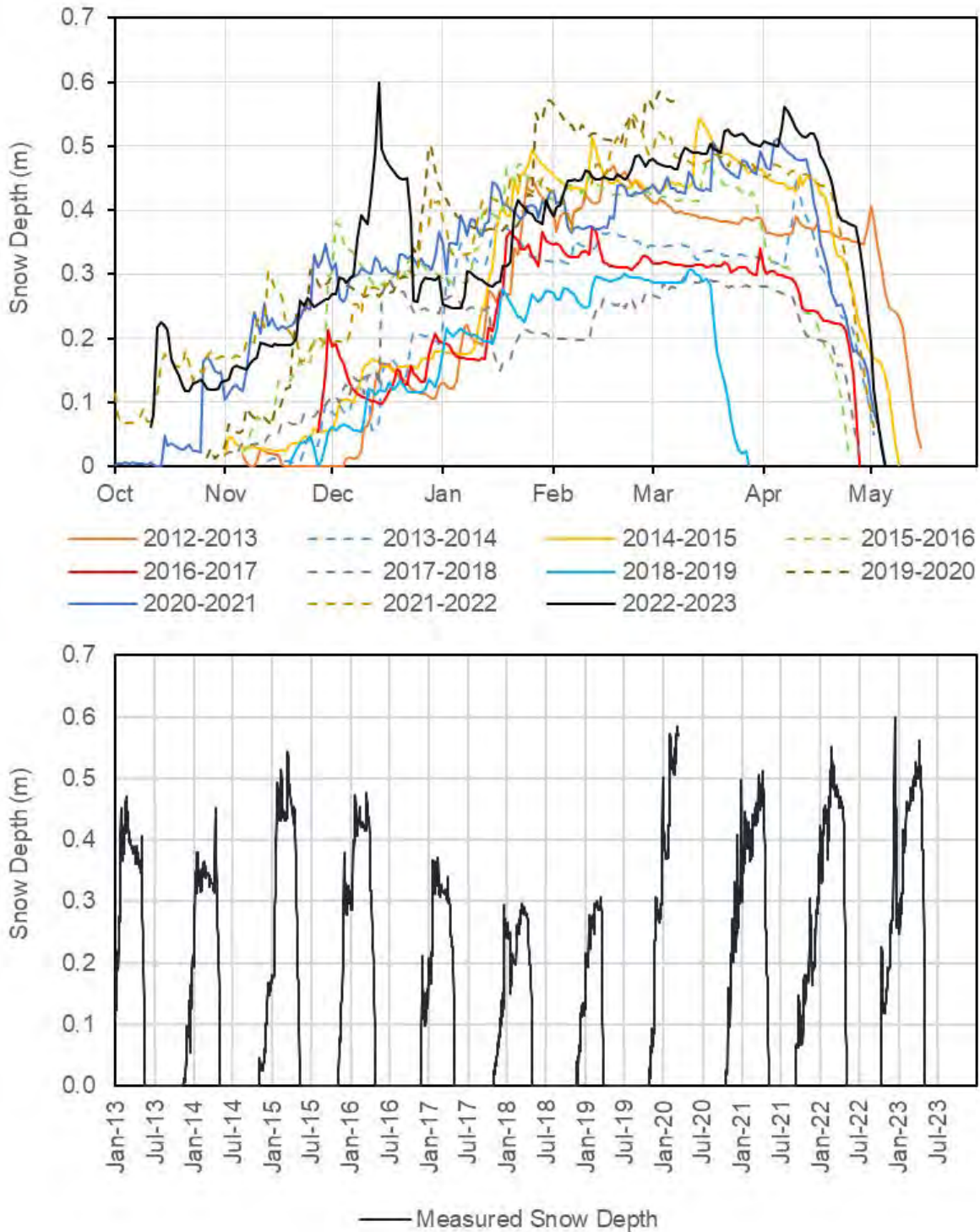

Figure 3.2-2: Summary of recent (2012-2023) continuous snow depth data for the Camp climate station

3.3 PHYSIOGRAPHY

The Mine is located within the Mayo Lake-Ross River Ecoregion, which encompasses the Stewart, Macmillan, and Pelly plateaus, a subdivision of the Yukon Plateau physiographic subdivision. Terrain consists of rolling upland plateaus and small mountain groups with nearly level tablelands dissected by deep and broad U-shaped valleys. Most of the terrain in the region lies between 500 and 1,700 m asl, while most of the slopes in the Mine area are between 15 to 30%. The local study area lies in the upper regions of the Haggart Creek drainage basin, including the Dublin Gulch and Eagle Creek sub-basins. Haggart Creek flows generally southwestward and into the South McQuesten River which ultimately eventually flows to the Stewart River.

Placer mining has been conducted in both Haggart Creek and the Dublin Gulch basins since the late 1890's. The outcome of these operations resulted in large placer deposits which altered the natural drainage character of Dublin Gulch, including channel diversions and some changes to sub-basin divides. The most notable changes affected Eagle Pup and Suttles Gulch. These water courses formerly entered into Dublin Gulch in the lower part of the valley. However, as a result of the placer mining activities, these drainages were diverted and helped to form Eagle Creek. As a result of constructing the mine, the Eagle Creek drainages have been further altered, principally by the construction of the LDSP along the drainage path of Eagle Creek, and subsequent diversion into the LDSP. Thus, the upper catchment area for Eagle Creek no longer flows into the lower section. The effects of this are discussed in Section 5.7 and in Section 6.1.1. After leaving the Dublin Gulch valley, Eagle Creek turns southward and flows parallel to Haggart Creek for several kilometres through placer deposits including several ponds before draining to Haggart Creek downstream of the mouth of Gil Gulch. Lynx Creek, the largest tributary to Haggart Creek, meets Haggart Creek about 3 km downstream of the Eagle Creek-Haggart confluence.

3.4 SURFACE WATER

3.4.1 Streamflow

Eleven currently operating hydrometric stations with the most complete records are described in Lorax (2024b) and include streamflow monitoring stations in Dublin Gulch, Haggart Creek, Lynx Creek, Stewart Gulch and Eagle Creek. Station locations and the associated metadata are presented in Figure 3.4-1 and Table 3.4-1, respectively,

Lorax (2024b) provides a recent summary of all hydrometric data through December 2023, and includes a summary of discharge measurement techniques, stage measurements and corrections, QA/QC of field data, approach and methods for hydrometric record assembly, and rating curve development and error. Over time, manual discharge measurements have been conducted using the following methods: velocity area techniques using a current meter; salt dilution; calibrated V-notch weir; calibrated Parshall flume; bucket/bag; and float-area method.

All continuously recording hydrometric stations at the Eagle Gold Mine have been instrumented with metric staff gauges and continuously recording HOBO pressure transducers set to record water levels every 15 minutes.

To develop continuous time-series of discharge for the Mine streams, spot measurements of stage and discharge were combined with continuous water level records collected by the pressure transducers. Rating curves were derived to describe the relationship between water level and discharge unique and specific to each monitoring station, and then applied to the continuous water level records to estimate discharge.

Table 3.4-2 provides a summary of monthly average discharge, unit yield and runoff for ten or the Mine site hydrometric stations listed in Table 3.4-1. The record for W45 is not sufficient to develop a rating curve, so W45

Section 3 Environmental Conditions

is not provided in Table 3.4-2. Flow records for all stations are presented in this format and as unit yield plots in Lorax (2024b).

Available site data confirm streamflow patterns seen in the regional record. The characteristic snowmelt driven freshet signature, which typically occurs between early May and early June is evident at site hydrology stations. The recession limb of the freshet tapers to a summer low-flow regime reflective primarily of groundwater, which is punctuated by periodic rainfall driven runoff events, typically one to four days in duration. Air temperatures at the Mine site begin to drop below zero in September. Accordingly, many of the smaller tributaries experience low- or zero-flow conditions for the majority of the winter season.

Table 3.4-1: Eagle Gold Mine Hydrometric Stations

Station ID	Station Name	Record Period	Northing	Easting	Drainage Area (km ²)	Median Basin Elevation (masl)	Notes ¹
W1	Dublin Gulch above Stewart Gulch	2007 - Date	7,101,545	460,249	7.0	1,303	Continuous discharge time-series
W4	Haggart Creek below Dublin Gulch	2007 - Date	7,101,223	458,144	76.8	1,125	Continuous discharge time-series
W5	Haggart Creek above Lynx Creek	2007 - Date	7,095,888	457,815	97.7	1,091	Continuous discharge time-series
W6	Lynx Creek above Haggart Creek	2007 - Date	7,095,964	458,099	100.9	1,049	Continuous discharge time-series
W21	Dublin Gulch near the Mouth	2018 - Date	7,101,261	458,359	10.1	1,216	Continuous discharge time-series; sensor malfunction in 2019 and 2020
W22	Haggart Creek above Dublin Gulch	2007 - Date	7,101,377	458,319	66.5	1,113	Continuous discharge time-series
W26	Stewart Gulch	2007 - Date	7,101,443	460,331	1.4	1,183	Continuous discharge time-series, manual data only for 2007 - 2009, 2011.
W27	Eagle Creek	2007 - Date	7,100,997	458,235	2.6	1,037	Continuous discharge time-series, manual data only for 2007
W29	Haggart Creek below Eagle Creek	2007 - Date	7,099,583	458,225	86.1	1,112	Manual measurements for 2010, continuous data thereafter; station destroyed by freshet flooding and moved to W99; manual only after 2016
W45	Eagle Creek at mouth	2018 – 2022	7,099,740	458,243	3.9	1,018	Continuous discharge time-series; sensor malfunction in 2021
W99	Haggart Creek upstream of 15 Pup	2019	7,098,180	458,322	88.3	1,116	Continuous discharge time-series

Note

¹ Continuous during ice-free months only.

Table 3.4-2: Summary of Monthly Average Discharge (2007-2022), Unit Yield and Runoff for Mine Site

Station (Discharge Area)	Variable	Jan	Feb	Mar	Apr	May	Jun	Jul	Aug	Sep	Oct	Nov	Dec	Average/ Total
W1 (6.8 km ²)	Average Discharge (m ³ /s)	--	--	--	0.024	0.329	0.139	0.092	0.084	0.084	0.102	0.069	--	0.115
	Average Yield (L/s/km ²)	--	--	--	3.5	48.4	20.4	13.5	12.4	12.3	15.0	10.1	--	17.0
	Runoff (mm)	--	--	--	5	71	51	36	32	32	21	4	--	252
W4 (76.9 km ²)	Average Discharge (m ³ /s)	--	--	--	0.376	2.383	1.234	0.851	0.868	0.885	0.887	--	--	1.069
	Average Yield (L/s/km ²)	--	--	--	4.9	31.0	16.0	11.1	11.3	11.5	11.5	--	--	13.9
	Runoff (mm)	--	--	--	1	57	40	30	30	30	18	--	--	205

Section 3 Environmental Conditions

Station (Discharge Area)	Variable	Jan	Feb	Mar	Apr	May	Jun	Jul	Aug	Sep	Oct	Nov	Dec	Average/ Total
W5 (97.5 km ²)	Average Discharge (m ³ /s)	--	--	--	--	3.121	1.499	1.049	1.018	1.040	1.166	--	--	1.482
	Average Yield (L/s/km ²)	--	--	--	--	32.0	15.4	10.8	10.4	10.7	12.0	--	--	15.2
	Runoff (mm)	--	--	--	--	61	38	29	27	28	14	--	--	197
W6 (100.9 km ²)	Average Discharge (m ³ /s)	--	--	--	--	4.056	1.273	0.955	1.096	1.188	1.148	0.574	--	1.470
	Average Yield (L/s/km ²)	--	--	--	--	34.7	10.7	8.7	10.5	11.2	9.9	5.7	--	13.1
	Runoff (mm)	--	--	--	--	65	29	24	28	30	15	3	--	194
W21 (10.1 km ²)	Average Discharge (m ³ /s)	--	--	--	--	0.280	0.182	0.103	0.105	0.087	0.116	--	--	0.146
	Average Yield (L/s/km ²)	--	--	--	--	27.7	18.8	10.6	11.7	9.1	11.9	--	--	15.0
	Runoff (mm)	--	--	--	--	46	40	23	16	16	13	--	--	153
W22 (66.8 km ²)	Average Discharge (m ³ /s)	--	--	--	0.407	2.212	1.057	0.706	0.793	0.775	0.824	0.937	--	0.964
	Average Yield (L/s/km ²)	--	--	--	6.1	33.1	15.8	10.6	11.9	11.6	12.3	14.0	--	14.4
	Runoff (mm)	--	--	--	9	59	40	27	29	29	17	15	--	225
W26 (1.3 km ²)	Average Discharge (m ³ /s)	--	--	--	--	0.029	0.014	0.010	0.013	0.011	0.009	--	--	0.014
	Average Yield (L/s/km ²)	--	--	--	--	22.6	10.6	8.2	9.5	8.0	7.0	--	--	10.9
	Runoff (mm)	--	--	--	--	30	23	21	25	20	8	--	--	128
W27 (2.7 km ²)	Average Discharge (m ³ /s)	--	--	--	0.007	0.054	0.026	0.022	0.020	0.018	0.023	--	--	0.024
	Average Yield (L/s/km ²)	--	--	--	2.5	20.0	9.5	8.3	7.4	6.6	8.5	--	--	9.0
	Runoff (mm)	--	--	--	3.0	38	23	19	19	17	9	--	--	127
W29 (86.1 km ²)	Average Discharge (m ³ /s)	--	--	--	--	2.552	1.267	1.049	1.095	1.037	1.018	--	--	1.336
	Average Yield (L/s/km ²)	--	--	--	--	29.6	14.7	12.2	12.7	12.1	11.8	--	--	15.5
	Runoff (mm)	--	--	--	--	41	33	33	33	31	18	--	--	189
W99 (90.1 km ²)	Average Discharge (m ³ /s)				1.503	3.104	1.689	0.950	0.955	0.938	1.451	--	--	1.513
	Average Yield (L/s/km ²)				17.0	35.1	19.1	10.8	10.8	10.6	16.4	--	--	17.1
	Runoff (mm)				19	56	49	28	29	28	20	--	--	229

Source: Lorax (2024b)

As part of site water management and compliance with the WUL, hydrometric data are also collected at several key watercourse stations as summarized in Table 3.4-3 and other additional internal minesite stations.

Table 3.4-3: Additional Hydrometric Stations Currently Active for the WMP

Station	Station Name	Northing ¹	Easting ¹	Notes
W4 mix	Haggart Creek below W4	7101136	458077	Located approximately 70 metres downstream of W4 at assumed location of good streamflow mixing
W8	Dublin Gulch below Olive Gulch	7101585	460346	Above potential effects from ROM Road crossing
W9	Eagle Pup	7101052	459630	Within Mine Footprint; Flows to Eagle Creek then into Ditch B
W10	Suttles Gulch	7100848	459158	Within Mine Footprint; Flows into Eagle Creek and then into Ditch B
W20	Bawn Boy Gulch	7101961	461945	--

Eagle Gold Mine
Water Management Plan

Section 3 Environmental Conditions

Station	Station Name	Northing¹	Easting¹	Notes
W23	Haggart Creek below Lynx Creek	7095683	457790	--
W25	Haggart Creek upstream of Fisher Gulch	7102196	458364	--
W30	Cascallen Gulch	7102034	461645	--
W31	Olive Gulch	7101619	461645	--
W39	Haggart Creek above South McQuesten River	7086504	449780	--
W49	South McQuesten River below Haggart Creek	7085495	449221	--
W51	Dublin Gulch downstream of Bawn Boy and Cascallen	7102040	461638	--
W61	Upper Eagle Creek upstream of Suttles	7100895	459139	--

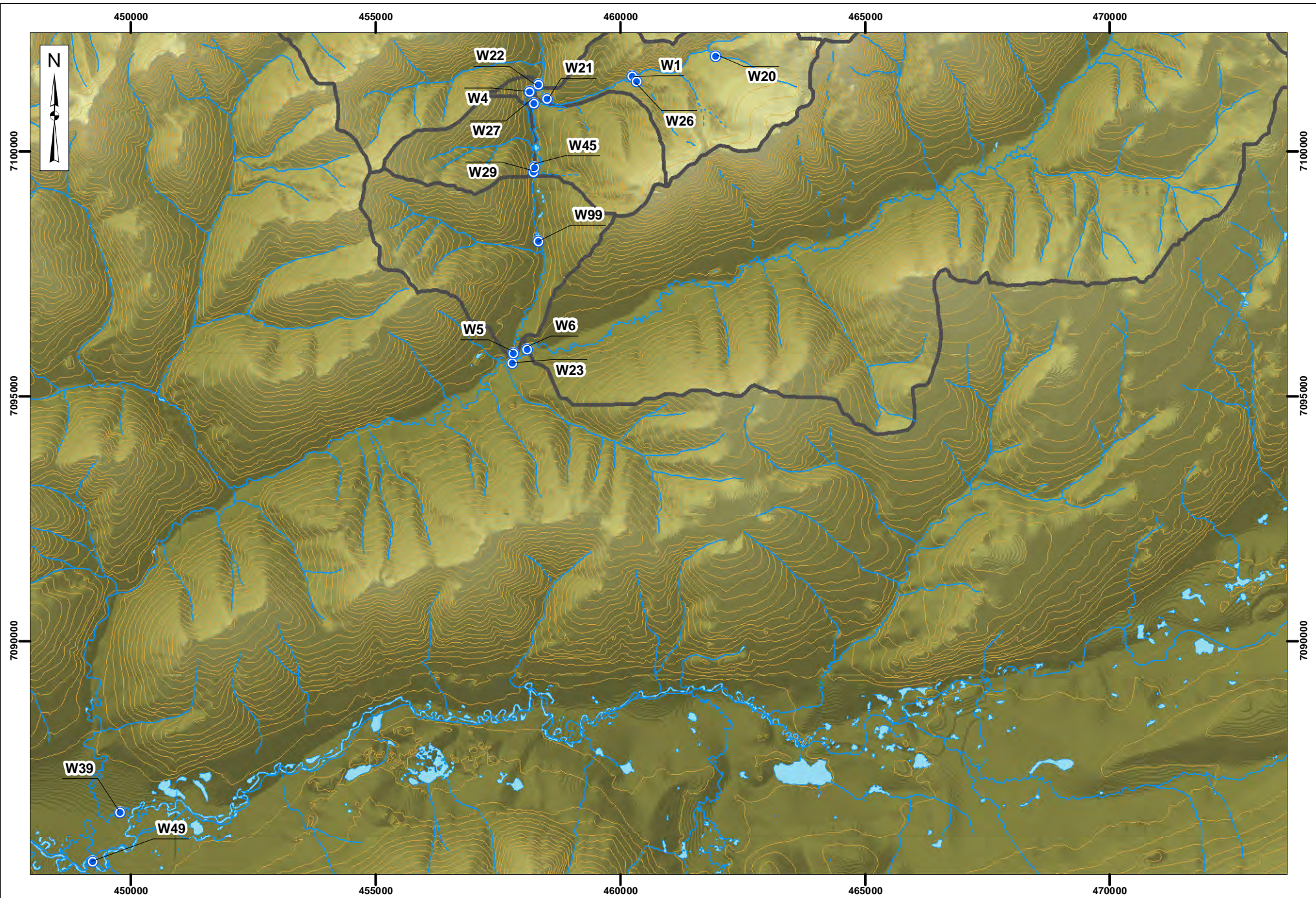

Legend:

	Surface Water Quality/Hydrometric Stations		Watercourse - Perennial
	Watershed Boundary		Watercourse - Ephemeral
	Contour (100ft)		Watercourse - Intermittent

VICTORIA GOLD CORP

0 0.75 1.5 3
Kilometers

Projection:
NAD 83
UTM Zone 8

Date:
2024-04-04

Drawn By:
HC

Figure:
3.4-1

**EAGLE GOLD MINE
YUKON TERRITORY**

Hydrometric and Water Quality
Sampling Station Network

3.4.2 Surface Water Quality

The current water quality and aquatic biota baseline program began in 2007. Stantec (2011a and 2012a), Lorax (2013), and Lorax (2017b) provide details on sample locations, sampling methods and frequency, and detailed summaries of results. Water quality characterization has occurred every year since 2007 and is still ongoing. The water quality data summaries provided in the subsection below reflect baseline conditions prior to construction, refer to the Annual Reports for 2018 through 2023 for summaries of SWQ data collected since 2017. The Annual Reports contain results for each year, which compares the concentrations for key water quality parameters at selected water quality monitoring stations for the reporting year to the baseline record and to AMP threshold values. Additionally, the SWQM results are updated annually for the Annual Report. The SWQM report provides plots for each receiving water station that compares results for key water quality parameters (all years) to model results.

The study area includes the Haggart Creek, Dublin Gulch, Eagle Creek basins, which have been subject to historical placer mining. Dublin Gulch and Eagle Creek basins have been affected by further development activities due to mine construction. The study area also includes Lynx Creek basin, which has not been subject to placer mining and will be unaffected by development activities. For the period of 2007 to 2016, a total of 21 monitoring stations were sampled within the study area. Monitoring of these stations continued during construction (2017-2019) and has continued during operations as EMSAMP. Since this data does not represent baseline conditions it is not reported on in this section, but as noted above is reported on in our monthly and annual reports submitted to the Yukon Water Board. The baseline data were used to establish water quality objectives and adaptive management criteria.

Portions of Haggart Creek, Dublin Gulch, and Eagle Creek drainage basins are located upstream, within or downstream of Mine activities, thus sampling sites were located upstream and downstream of the Mine footprint. Lynx Creek drains a large catchment to the south of the Mine area that is unaffected by development activities and serves as a reference monitoring location; however, as Lynx Creek will be unaffected by the Mine it is not summarized in this management plan.

3.4.2.1 Dublin Gulch Drainage

The major ion chemistry of Dublin Gulch is assessed with respect to conductivity, hardness, alkalinity, sulphate and pH. Dublin Gulch is characterized by soft to moderately hard waters, with monthly mean hardness values ranging from 28 to 66 mg/L at station W1 (downstream) and 47 mg/L to 145 mg/L at station W21 (upstream). Values for conductivity, hardness, and alkalinity demonstrate pronounced seasonal fluctuations, with minima coinciding with freshet periods in May and June. Conductivity, hardness and alkalinity at both sites exhibit an approximate two- to three-fold increase in concentration between freshet and other times of the year.

Overall, such trends in stream salinity reflect varying proportions of snow-melt driven surface runoff (lower ionic strength) and groundwater inputs (higher ionic strength) as driven by the seasonal water balance. Values upstream are typically higher than values downstream, and may reflect the contribution from groundwater discharges at lower elevations in the catchment.

The pH in Dublin Gulch remains relatively uniform throughout the year with values generally ranging between 7.0 and 8.0. The neutral to slightly basic pH conditions can be linked to bicarbonate alkalinity. All pH values reported to date have remained within the BC freshwater chronic criterion range for pH of 6.5 to 8.5.

Baseline concentrations for sulphate in Dublin Gulch are generally low, and exhibit a pronounced seasonal signature as observed for other salinity proxies. Sulphate minima during high flow can be attributed to the influence of low ionic strength melt waters, while higher values during the low-flow periods likely reflect an increased proportion of groundwater inputs.

Mean monthly sulphate values range from freshet minima of approximately 6.0 mg/L and 17 mg/L, respectively to maximum mean values observed during winter low flows of 20 mg/L and 65 mg/L, respectively.).

Unlike the dissolved ions, elevated TSS concentrations in Dublin Gulch generally coincide with the peak snowmelt month of May or during intense rainfall events. At most other flow periods of the year, TSS values in Dublin Gulch were generally below the analytical detection limit of 3.0 mg/L. Peak TSS values measured for the period of 2007 to 2016 were 103 mg/L (May 2014) and 37 mg/L (May 2011), respectively.

Nutrients quantified in Dublin Gulch include nitrate (NO₃⁻), nitrite (NO₂⁻), ammonia (NH₃), total phosphate (T-PO₄₃⁻), and dissolved orthophosphate (D-o-PO₄₃⁻). In overview, nutrient parameters show low values in Dublin Gulch. Ammonia-N concentrations in Dublin Gulch are low with mean monthly values ranging from <0.005 mg/L to 0.028 mg/L.

Ammonia-N concentrations are expected to remain low in Dublin Gulch due to the low persistence of ammonia in fully oxygenated freshwaters at neutral pH. Similar to ammonia, the majority of nitrite-N values have occurred near or below the detection limit value. Baseline nitrate-N concentrations in Dublin Gulch are also low, with mean monthly values ranging from approximately 0.006 to 0.2 mg/L. Minima are evident during high flow periods, reflecting melt water influences. During lower flow periods, Dublin Gulch is characterized by higher nitrate-N concentrations, again likely reflective of a greater proportion of groundwater derived flow.

Primary productivity in freshwaters is typically limited by available phosphorus. Accordingly, measurements of phosphorus compounds in surface waters can provide an indication of trophic status (i.e., productivity regime). Baseline concentrations for dissolved orthophosphate in Dublin Gulch are low, ranging from approximately <0.0020 to 0.005 mg/L.

Total organic carbon (TOC) reflects a combination of dissolved organic carbon (DOC) and particulate phases associated with both aquatic and terrestrial organic matter. Highest values of TOC and DOC are typically observed during high flow periods, likely reflecting contributions of particulate carbon associated with terrestrial runoff and within-stream re-suspension. In contrast, low and uniform values prevail during low flow conditions, during which time TOC is predicted to be present primarily as dissolved phases. Mean monthly baseflow TOC levels in Dublin Gulch are lowest at W1 (1.0 mg/L) and slightly higher at W21 (1.4 mg/L). Freshet flow TOC levels are higher and typically exceed 10 mg/L.

Baseline trace element concentrations in Dublin Gulch were derived from data collected from August 2007 to July 2016. In general, mean monthly concentrations of total and dissolved trace elements are low (e.g., Sb, Cu, Co, Cr, Pb, Hg, Se, Tl and Zn). However, Dublin Gulch is characterized by elevated total and dissolved As concentrations throughout its reaches with generally low variability in measured concentrations throughout all flow conditions.

Total Al and total Cd are also observed to be elevated during peak flow months; higher total concentrations are associated with elevated TSS levels. Total and dissolved Al values correlate positively with flow and elevated TSS, with dissolved Al reaching a mean monthly maximum of 0.15 mg/L at W1 to 0.17 mg/L at W21 in May. The correlation between dissolved and total fractions strongly suggests that the dissolved Al fraction is governed by

colloidal Al hydroxides that are able to pass through a 0.45 µm filter membrane. During non-peak flow periods, dissolved Al concentrations in Dublin Gulch are typically an order of magnitude lower than total concentrations.

3.4.2.2 Eagle Creek Drainage

The major ion chemistry of Eagle Pup and Eagle Creek is described with respect to conductivity, hardness, alkalinity, sulphate and pH. Eagle Pup is characterized by moderately hard to hard waters, with monthly mean hardness values ranging from 94 to 285 mg/L. Hardness values in lower Eagle Creek are slightly lower but are characterized as moderately hard to hard with monthly mean hardness ranging from 83 mg/L to 212 mg/L at station.

Like the other Mine area streams, values for conductivity, hardness, and alkalinity demonstrate pronounced seasonal fluctuations, with minima coinciding with freshet periods in May and June during peak periods of snowmelt runoff. The pH in Eagle Creek remains relatively uniform throughout the year, with values generally ranging between 7.5 and 8.4. Alkalinity values in excess of 150 mg/L are typical and represent significant buffering capacity and dissolution of carbonate mineral phases in the catchment.

Baseline concentrations for sulphate in Eagle Creek are notably higher (e.g., ~60 mg/L during nonfreshet flow conditions) than observed in Dublin Gulch (~20 mg/L) for corresponding flow periods. The higher sulphate concentrations in the Eagle Creek drainage likely reflect the presence and weathering of the low-sulphide Eagle Gold deposit.

TSS concentrations observed in the Eagle Creek drainage were highly variable depending upon location in the catchment. The seasonal TSS signature was similar to that observed in Dublin Gulch, exhibiting higher concentrations in peak freshet months (e.g. > 30 mg/L) and lower concentrations during lower flow periods. Conversely, the highest mean monthly TSS concentrations corresponded to freshet (April/May) as well as summer (e.g. July and August) flow periods. The elevated TSS concentrations in Eagle Creek at station W27 had a significant influence on total trace element concentrations as described below.

Nutrient parameters show low values in the Eagle Creek drainage. Ammonia-N concentrations are low with mean monthly values ranging from <0.005 mg/L to 0.011 mg/L at W9 and <0.005 mg/L to 0.059 mg/L at W27. The majority of nitrite-N values have occurred near or below the detection limit value. Baseline nitrate-N concentrations during low flows in Eagle Creek are higher (e.g. ~0.02 to 0.30 mg/L) than observed in Dublin Gulch (e.g. 0.1 mg/L).

Baseline concentrations for dissolved orthophosphate in Eagle Creek are low, ranging from approximately <0.0020 to 0.005 mg/L. Mean monthly baseflow TOC levels in Eagle Creek are typically 1.0 mg/L to 2.0 mg/L, while freshet flow TOC levels are on the order of 15 to 20 mg/L.

Baseline trace element concentrations in upper Eagle Creek were derived from data collected from July 2009 to May 2013. Characterization of baseline water quality in lower Eagle Creek was developed using data collected from August 2007 to October 2014. Because of the influence of Suttles Gulch, the data from W9 and W27 are described separately below.

Upper Eagle Creek (Eagle Pup)

In general, mean monthly concentrations of total and dissolved trace elements in the upper Eagle Creek basin are low, with concentrations of key parameters of interest (e.g. Cd, Cu, Co, Cr, Pb, Hg, Ni, Se, Tl and Zn) measured at, or below, their respective analytical detection limit. However, total and dissolved arsenic concentrations are naturally elevated in the head waters of Eagle Creek. During low flow conditions, total and

dissolved As concentrations are similar and typically range between 0.018 mg/L and 0.022 mg/L with dissolved As accounting for over 95% of total As.

Episodic periods of higher flow and elevated TSS values result in elevated total As values that have been observed to range from approximately 0.033 mg/L to values approaching 0.06 mg/L. These brief periods of elevated total As do not translate into higher dissolved As concentrations which show decreased dissolved As concentrations during freshet months (e.g. 0.012 mg/L) and near consistent low flow dissolved concentrations of approximately 0.02 mg/L. The dissolved data suggest that solid-phase As associated with higher TSS is primarily responsible for peak concentrations observed. The periods of elevated TSS also result in higher concentrations of trace elements (namely Al, Cd, Mn and Ag).

Lower Eagle Creek

Lower Eagle Creek has experienced periods of very elevated TSS since mid-2010 to present. These periods of elevated TSS result in elevated concentrations of total trace elements, in particular Al, As, Cd, Cu, Pb, Hg, Mn, Ni, Ag and Zn. Total As concentrations during these elevated TSS events can exceed 0.450 mg/L (and is directly attributable to solid-phase As in suspended sediments).

Conversely, dissolved As concentrations, while higher than observed in the upper reaches of Eagle Creek at W9, remain consistently between 0.025 mg/L and 0.036 mg/L (e.g. during winter low flow) and 0.03 and 0.049 mg/L during summer flow periods. Based on these results, baseflow As concentrations in upper Eagle Creek basin are approximately 0.02 mg/L and increase further down the catchment to roughly 0.028 mg/L.

3.4.2.3 Haggart Creek Drainage

Upper Haggart Creek above Dublin Gulch

The major ion chemistry of upper Haggart Creek is described with respect to conductivity, hardness, alkalinity, sulphate and pH. Upper Haggart Creek is characterized by moderately hard to hard waters, with monthly mean hardness values ranging from approximately 63 to 216 mg/L. Like the other Mine area streams, values for conductivity, hardness, and alkalinity demonstrate pronounced seasonal fluctuations, with minima coinciding with freshet periods in May and June during peak periods of snowmelt-driven runoff. The pH in upper Haggart Creek remains relatively uniform throughout the year with mean values generally ranging between 7.3 and 8.0. Alkalinity values are typically in excess of 85 mg/L suggesting a well-buffered system. Lower alkalinity values are only experienced during freshet periods.

Baseline concentrations for sulphate in upper Haggart Creek are notably higher (e.g., ~60 to 93 mg/L) during non-freshet flow conditions as compared to peak snowmelt periods where values typically less than 25 mg/L sulphate are observed. TSS concentrations in upper Haggart Creek exhibit freshet maxima, generally coinciding with the peak snowmelt month of May. At most other flow periods of the year, TSS values in upper Haggart Creek were generally below the analytical detection limit of 3.0 mg/L. The peak TSS value measured for the period of 2007 to 2016 was approximately 80 mg/L.

Nutrient parameters show low values in upper Haggart Creek. Ammonia-N concentrations are low with mean monthly values ranging from <0.005 mg/L to 0.022 mg/L at W22. Similar to ammonia, the majority of nitrite-N values have occurred near or below the detection limit value. Baseline nitrate-N concentrations in upper Haggart Creek are also low, with mean monthly values ranging from approximately 0.03 to 0.16 mg/L. Minima are evident during high flow periods, reflecting melt water influences.

Like other Mine area streams, baseline concentrations for dissolved orthophosphate in upper Haggart Creek are low, ranging from approximately <0.0010 to 0.0013 mg/L. Mean monthly baseflow TOC levels in upper Haggart Creek are low and generally less than 1.5 mg/L. Freshet flow TOC levels are much higher at approximately 25 mg/L, reflecting the addition of terrestrial-derived runoff and organic detritus.

In general, mean monthly concentrations of total and dissolved trace elements are low for all parameters monitored with the exception of Al, Mn and to a lesser extent Cd during the peak freshet month of May. Most parameters are present at concentrations at or below their respective analytical detection limit. Unlike Dublin Gulch and Eagle Creek drainages, arsenic concentrations in upper Haggart Creek at W22 are low; mean monthly concentrations range from a high of 0.004 mg/L during freshet periods to values typically less than 0.0008 mg/L for the remaining flow periods.

Upper Haggart Creek below Dublin Gulch

The major ion chemistry of Haggart Creek downstream of Dublin Gulch is similar to that observed at above Dublin Gulch with waters characterized as moderately hard to hard. Monthly mean hardness values range from approximately 56 to 209 mg/L with minima coinciding with freshet periods in May and June during snowmelt runoff. The pH is well buffered and relatively uniform throughout the year with values ranging between 7.3 and 8.0. Alkalinity values are lowest in the high flow periods (e.g. approximately 35 mg/L) and greatest in low flow periods (e.g. approximately 120 mg/L).

Sulphate concentrations are slightly lower than observed above Dublin Gulch as a result of the addition of low sulphate loadings from Dublin Gulch. The lowest sulphate concentrations are observed during May and June (e.g. 20 mg/L to 45 mg/L); higher sulphate concentrations are measured during non-freshet flow conditions (e.g. ~60 mg/L to ~90 mg/L).

TSS concentrations are similar to those observed above Dublin Gulch with the exception that higher TSS values below DG occur as a result of suspended solids loadings from Dublin Gulch during peak snowmelt months of May and June. At most other flow periods of the year, TSS values are generally below the analytical detection limit of 3.0 mg/L, with the exception of episodic summer rainfall events that increase suspended sediments loads in the Eagle Creek drainage and to a lesser extent in the Haggart Creek drainage.

Not surprisingly, nutrient parameters in Haggart Creek below Dublin Gulch are low with ammonia-N, nitrate-N and orthophosphate values being very similar in concentration to those observed in Haggart Creek above Dublin Gulch.

Trace element concentrations are very similar to those observed above Dublin Gulch with the sole exception of As. Specifically, mean monthly concentrations of total and dissolved trace elements are low for all parameters monitored with the exception of Al, Mn and to a lesser extent Cd during the peak freshet month of May. Arsenic concentrations are roughly four times that observed above Dublin Gulch. The reason for the increased As concentrations is due to significant natural As loadings entering from Dublin Gulch. Winter low flow mean monthly As concentrations range from 0.0013 mg/L to 0.0018 mg/L (December to March) to summer flow concentrations of approximately 0.0042 mg/L. 95th percentile values for total As for the same winter low flow and summer low flow conditions range from 0.0015 mg/L to 0.0025 mg/L and from 0.0044 mg/L to 0.0061 mg/L, respectively.

Haggart Creek below Eagle Creek

Haggart Creek below Eagle Creek is characterized as moderately hard to hard water. Monthly mean hardness values range from approximately 67 to 232 mg/L with minima coinciding with freshet periods in May and June during snowmelt runoff. Hardness values and alkalinity are slightly higher in this location relative to upstream in

Haggart Creek; the greater alkalinity and hardness in the section below Eagle Creek is a result of Ca, Mg inputs from Eagle Creek. The pH in Haggart Creek at below Eagle Creek is well buffered and relatively uniform throughout the year with values ranging between 7.4 and 8.1. Alkalinity values are lowest in the high flow periods (e.g. approximately 40 mg/L) and greatest during low flow periods (e.g. approximately 130 mg/L).

Sulphate concentrations are slightly higher than observed at the Haggart Creek segment below Dublin Gulch for the low flow months (e.g. January to April) and reflect higher sulphate loadings from Eagle Creek. During peak flow periods, sulphate concentrations in Haggart Creek from are not significantly different moving downstream and typically range from approximately 20 mg/L to 60 mg/L.

TSS concentrations are higher than those observed upstream during the peak flow periods and likely reflect the higher TSS loadings from Dublin Gulch and Eagle Creek. At most other flow periods of the year, TSS values are generally below the analytical detection limit of 3.0 mg/L with the exception of episodic summer rainfall events that increase suspended sediments loads in Haggart Creek sub-basins.

Nutrient parameters are low with ammonia-N, nitrate-N and orthophosphate values being very similar in concentration to those observed in Haggart Creek above Dublin Gulch.

Water quality in Eagle Creek has a notable influence on water quality conditions in Haggart Creek below Eagle Creek. The high TSS loadings occurring in Eagle Creek, particularly during freshet conditions, result in elevated concentrations of total trace elements, in particular Al, As, Cd, Cu, Pb, and Mn. The most significant trace metal increases are associated with total arsenic. Total As concentrations are typically greater below Eagle Creek as compared to above Dublin Gulch during most flow periods of the year and can be particularly elevated during peak flow events. As with the other trace metal parameters, the elevated total As concentrations can be associated with the increased TSS loadings derived from Eagle Creek.

Mean As concentrations were calculated using all monitoring results for each station. Mean arsenic concentrations in Haggart Creek above Dublin Gulch (0.0009 mg/L) increase to values of approximately 0.0038 mg/L downstream following inputs from Dublin Gulch. Below Eagle Creek, mean arsenic concentrations in Haggart Creek increase to values of approximately 0.006 mg/L. Farther downstream, mean arsenic concentrations decrease to values of roughly 0.0045 mg/L. Although Lynx Creek is an undisturbed catchment, arsenic is also naturally elevated in drainage waters with a mean arsenic concentration of 0.0064 mg/L and as a result, mean arsenic concentrations below the confluence with Lynx Creek, are observed to increase to 0.0056 mg/L.

3.5 GROUNDWATER

Material property data available for the Mine comprises results of packer tests, slug tests and pumping tests from drilled bore holes and wells at site. Hydraulic head data (instantaneous and continuous) have been collected from 104 monitoring wells, standpipe piezometers, vibrating wire piezometers, and aquifer test wells (Stantec 2010, BGC 2012a, BGC 2012b and BGC 2013a), located across eight different sub-basins that include Bawn Boy Gulch, Olive Gulch, Stewart Gulch, Eagle Pup, Suttles Gulch, Platinum Gulch, Dublin Gulch, and Ann Gulch. In addition, since 2009 water quality data have been collected on a regular basis from 18 of the site monitoring wells in these same sub-basins. The groundwater level and groundwater quality data collection program that began in 2009 is still on-going. The data obtained has been used to identify local groundwater recharge and discharge zones, groundwater flow patterns, characterize groundwater quality and to develop a numerical hydrogeological model (BGC 2014) which was updated in 2019 (BGC 2019).

3.5.1 Hydrogeologic Setting

There are two principal water-bearing units in the Mine area: deeper relatively low permeability bedrock and the near-surface moderately permeable surficial deposits. Surficial material at the Mine site consists of a thin veneer of organic soils underlain by colluvium (i.e., a loose heterogeneous mass of soil material), glaciofluvial deposits (i.e., originating from rivers associated with glaciers), or till (a glacial deposit). Below these clastic (i.e., transported broken fragments of rock) units are either metasedimentary or granodiorite bedrock, which is deeply weathered in places. The elongated granodiorite stock (ore bearing unit) has intruded the surrounding host metasediment. The surficial material thickness and physical properties varies significantly throughout the area.

The Dublin Gulch valley contains large amounts of fluvial materials that were considerably reworked by placer mining operations. Extensive stockpiles of placer deposits comprised of sub-rounded metasediment and granodiorite clasts, ranging in size from sands to boulders, and fine-grained material (i.e., that are located in former placer settling ponds) are present adjacent to the Dublin Gulch and Eagle Creek watercourses. A till blanket covered with a colluvial veneer is located along the south valley wall in Dublin Gulch valley and extends southward in the Haggart Creek valley. A recent alluvial fan is present where Dublin Gulch meets Haggart Creek. Discontinuous permafrost is also present, especially on the north-facing slopes and affects the connectivity between the deep and shallow water-bearing zones in places. Further details of the spatial distribution and characteristics of surficial materials are found in Stantec (2011b).

3.5.2 Groundwater Occurrence and Groundwater Level Monitoring

There are two groundwater level monitoring programs: 1) the site-wide program that began in 2009 and conducted as part of the EMSAMP, and 2) an open pit program that began in 2020 as part of the monitoring of depressurization behind the pit walls.

3.5.2.1 Sitewide Groundwater Level Monitoring

The objectives of the groundwater quantity monitoring program (as a part of the EMSAMP) have been to provide continuous and spot level groundwater level measurements to monitor potential Mine effects on the occurrence and quantity of groundwater. Groundwater level data have been collected since 2009 from the wells/piezometers installed throughout the Mine footprint. Continuous recording data loggers have been used at selected locations on site to provide a better understanding of seasonal variability in areas of current and planned infrastructure.

Instantaneous groundwater level and continuous water level data logger information collected from 2009 to 2023 were compiled by BGC (2024) and are depicted in hydrograph plots of groundwater elevations measured for each monitoring wells since their respective installation. Data compilation and analytical methods for processing the groundwater level data are most recently described in BGC 2024 and are provided with the Annual Report for 2022.

Generally, groundwater has been observed deeper (approximately >6 m below ground) at higher elevations and shallow to artesian in lower elevations and in valley bottoms. Springs and seeps have been observed in a few locations where valley bottoms have narrowed. These are typically associated with the re-emergence of a stream from channel deposits (i.e., a gaining reach). In these instances (e.g., Eagle Pup, Stewart Gulch), thin alluvium overlying shallow bedrock is the likely cause of the emergence. The interpreted piezometric surface appears to generally mimic the surface topography (see Figures 3 and 4 in BGC 2019).

Four representative examples (from BGC 2024) depicting seasonal variability and continuous data recording are provided below, including MW96-9b (located upstream of any Mine effects in Bawn Boy Gulch), MW19-LDSP-2B

(located in the Dublin Gulch valley and downgradient of the LDSP), MW19-EPW1a (located in the Eagle Pup valley downgradient from the EP WRSA), and MW10-PG1 (located in mid Platinum Gulch valley downgradient from the PG WRSA). As described in previous reports (Stantec 2012b, BGC 2013, and BGC 2014), and for the 2018-2023 Annual Reports the well network hydrographs have demonstrated some range in seasonal variability (since 2009), with fluctuating water elevation generally being 2m to 5m throughout the year, but over 10 m have been recorded. In the four examples, the continuous data indicate ~2m, ~3m, ~5m, and ~5m of seasonal variability at MW10-PG1, MW19-EWP1a, MW96-9b and MW19-LDSP2b, respectively. Groundwater levels are characterized with relatively high-water levels during spring freshet and fall precipitation events, and relatively low water levels related to dry summer and frozen winter conditions. The available data indicate that the groundwater table generally mimics the surface topography, with recharge along topographic highs, and discharge along creeks and gullies. Small but discernible responses to precipitation events were observed in the wells with continuously recording dataloggers. The hydrographic data presented with the 2023 Annual Report do not indicate any increasing or decreasing trends or measurable effects from mining activities on groundwater levels.

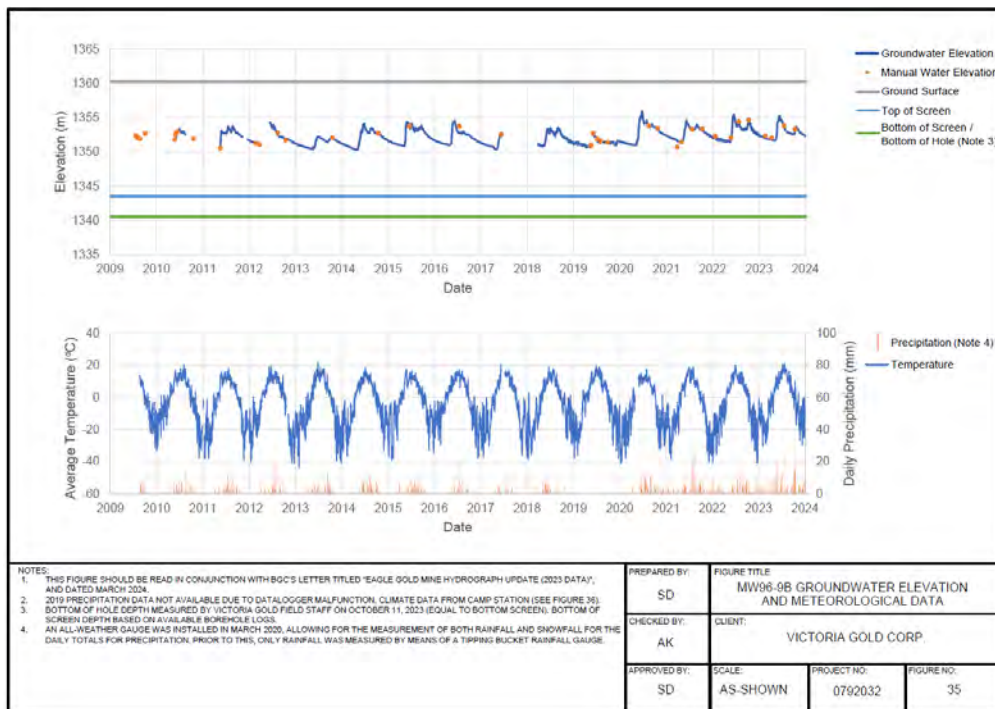

Figure 3.5-1: 2009 to 2023 Groundwater Hydrograph for MW96-9b - Bawn Boy Gulch Upgradient from Mine Effects

Section 3 Environmental Conditions

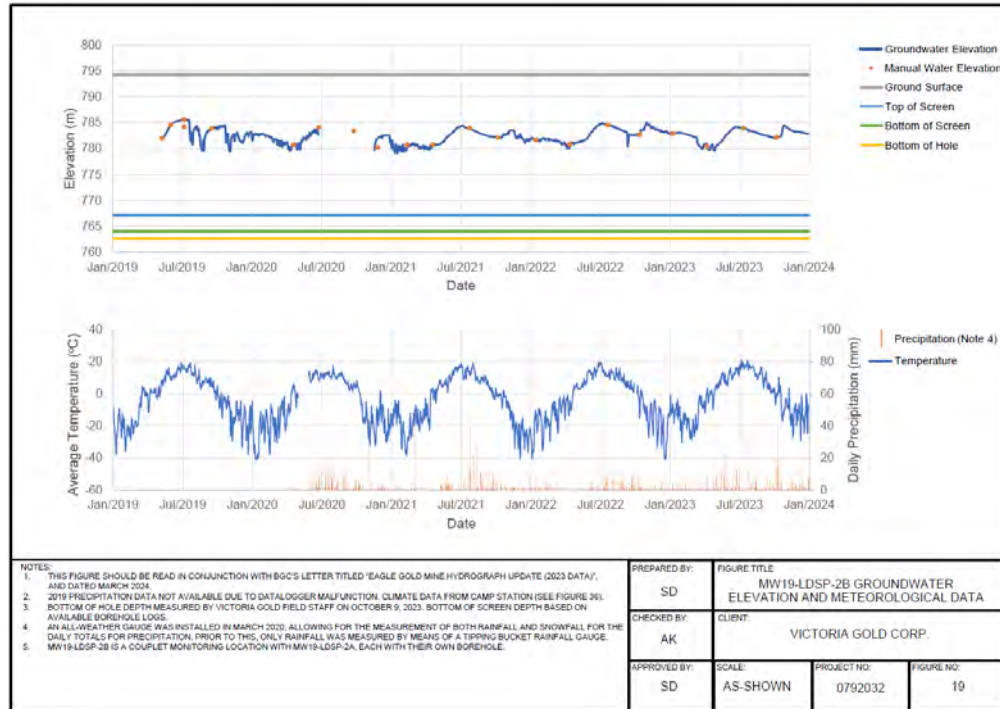

Figure 3.5-2: 2019 to 2023 Groundwater Hydrograph for MW19-LDSP-2B - Dublin Gulch Valley Downgradient from LDSP and Mine Effects

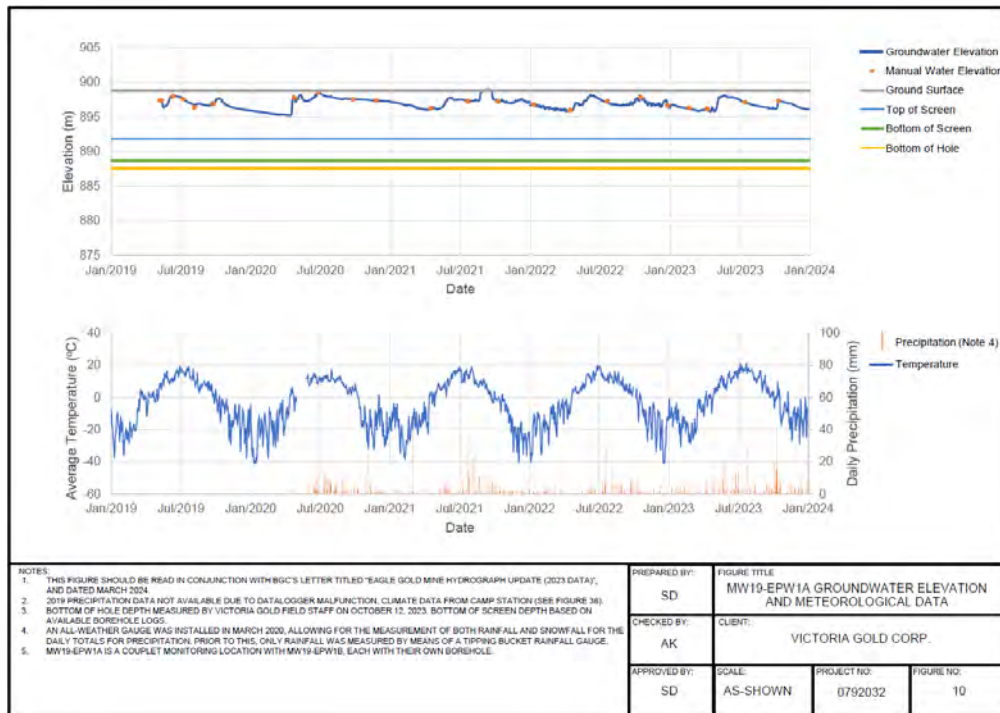

Figure 3.5-3: 2019 to 2023 Groundwater Hydrograph for MW19-EPW-1A - Lower Eagle Pup Valley Downgradient of EP WRSA and Mine Effects

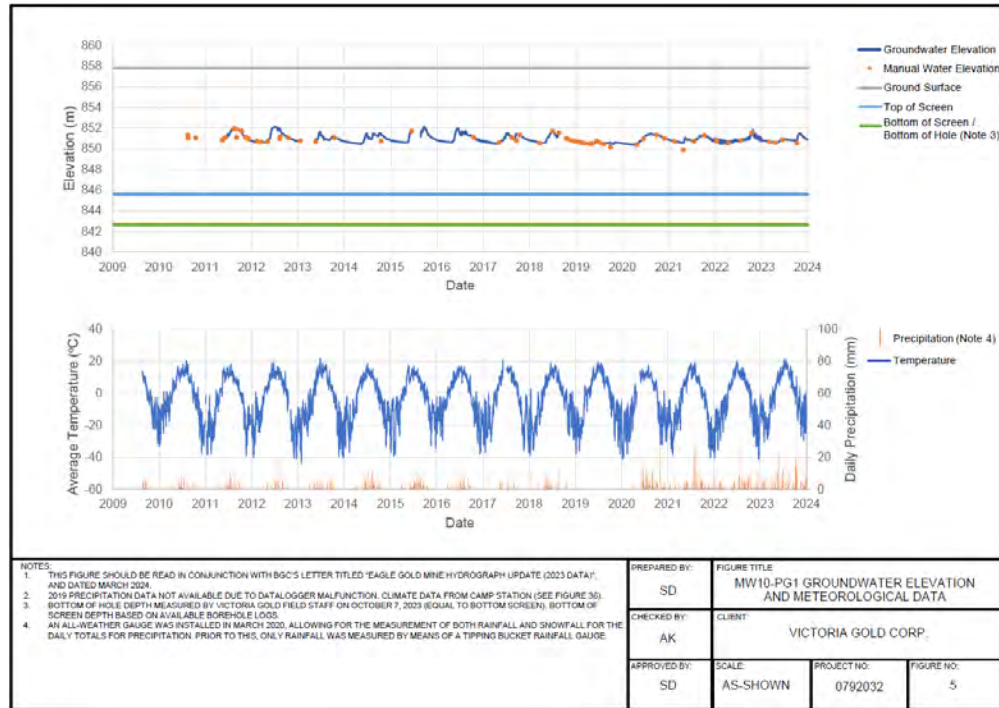

Figure 3.5-4: 2010-2023 Groundwater Hydrograph for MW10-PG1 - Mid Platinum Gulch Valley Downgradient of PG WRSA and Mine Effects

3.5.2.2 Eagle Pit Depressurization Drainholes

As the Eagle Pit has advanced since production, pit wall stability and the effectiveness of depressurization has become more important. Initially, due to relatively deep levels of groundwater below successive benches, depressurization was accomplished passively through natural groundwater seeps that formed along certain fracture zones on the pit walls. As the excavation deepened, more active depressurization methods were required. Commencing in the summer of 2022 and continued in 2023, a series of horizontal drainholes were installed. As a result, the total water flow emanating from the pit walls has increased over the last few years. This water, ultimately conveyed into Ditches A and B has added to the overall water flow into the LDSP.

Each HDH was completed with a valve to control and measure seepage flow and collect water quality samples if needed.

3.5.2.3 Eagle Pit Depressurization Monitoring

As summarized in the 2022 Annual Report, since 2020, as part of overall geotechnical stability monitoring, depressurization monitoring of the pit walls has been conducted with the use of piezometers strategically placed around and within pit limits and targeting different pit phases. Piezometer readings are set on a datalogger to read twice a day, and the data is collected weekly when access is available and monthly during winter when vehicle access is not always available.

Some piezometers were located in sacrificial areas where the pit ultimately advanced (i.e., located along interbenches of relatively early phases of pit development), while others are located up or cross-gradient of all pit development to monitor piezometric pressures throughout the life of the mine. By the end of 2023, there were still four active nested piezometers (Deep-08-VW1, VW2 and VW3; BH21-05A-VW1, VW2 and VW3; BH22-06B-

Section 3 Environmental Conditions

VW1, VW2 and VW3; and, GT23-05-VW1, VW2 and VW3), while two others (Deep-04-VW1, VW2 and VW3; and Deep-06-VW1, VW2, and VW3) were retired.

Table 3.5-1 summarizes the status of all piezometers in and around the Eagle Pit by the end of 2023.

Table 3.5-1: Eagle Pit Year End 2022 Eagle Pit Piezometer Status

Piezometer	Year Installed	Status	Location	Tip Elevation (masl)	Purpose
DEEP-08 – VW1	2020	Active	Ex-pit	879.5	Future Phase 3 Monitoring
DEEP-08 – VW2	2020	Active	Ex-pit	931.4	Future Phase 3 Monitoring
DEEP-08 – VW3	2020	Active	Ex-pit	987.7	Future Phase 3 Monitoring
DEEP-06 – VW1	2021	Retired	In-Pit – Phase 2	1049.5	Phase 2 Wall Monitoring
DEEP-06 – VW2	2021	Retired	In-Pit – Phase 2	1134.0	Phase 2 Wall Monitoring
DEEP-06 – VW3	2021	Retired	In-Pit – Phase 2	1213.9	Phase 2 Wall Monitoring
DEEP-04 – VW1	2021	Retired	In-Pit – Phase 2	975.1	Phase 1 Wall Monitoring
DEEP-04 – VW2	2021	Retired	In-Pit – Phase 2	1038.6	Phase 1 Wall Monitoring
DEEP-04 – VW3	2021	Retired	In-Pit – Phase 2	1102.0	Phase 1 Wall Monitoring
BH21-05A – VW1	2021	Active	Ex-Pit	1186.1	Phase 3 South Wall Monitoring
BH21-05A – VW2	2021	Active	Ex-Pit	1236.3	Phase 3 South Wall Monitoring
BH21-05A – VW3	2021	Active	Ex-Pit	1268.9	Phase 3 South Wall Monitoring
BH21-06B – VW1	2021	Active	Ex-Pit	1236.7	Phase 3 East Wall Monitoring
BH21-06B – VW2	2021	Active	Ex-Pit	1272.0	Phase 3 East Wall Monitoring
BH21-06B – VW3	2021	Active	Ex-Pit	1356.9	Phase 3 East Wall Monitoring
GT23-05 – VW1	2023	Active	Ex-Pit	1178.8	Northeastern Wall Monitoring
GT23-05 – VW2	2023	Active	Ex-Pit	1230.8	Northeastern Wall Monitoring
GT23-05 – VW3	2023	Active	Ex-Pit	1279.1	Northeastern Wall Monitoring

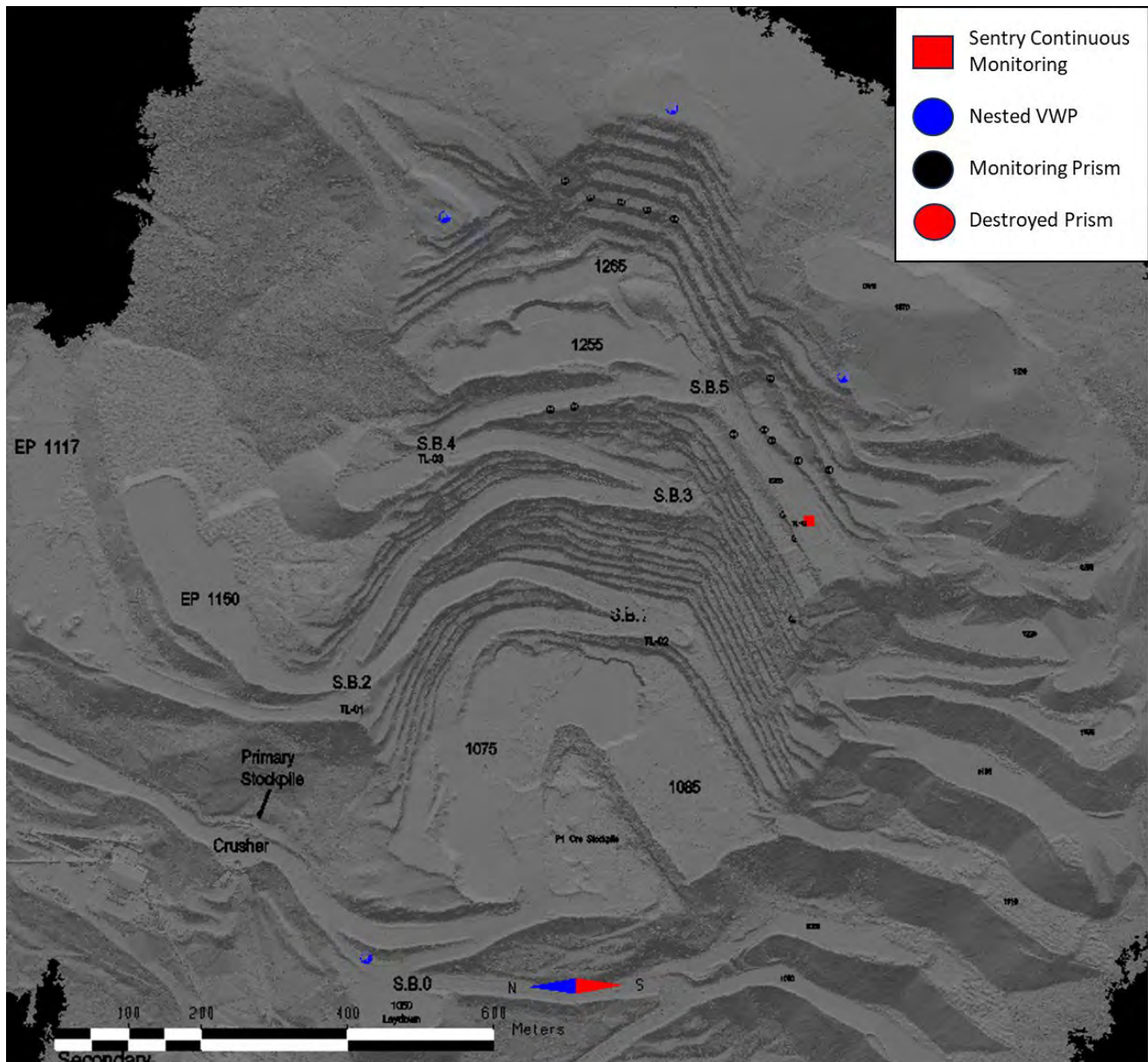

Figure 3.5-5: Active Eagle Pit Piezometers During 2023

3.5.3 Groundwater Flow

Groundwater flow in the bedrock occurs in fractures and fault zones, while preferentially flowing through more permeable (and porous) sediments within the surficial deposits. Fracture flow has been very evident in the Eagle Pit. As the pit has widened and deepened exposing major fracture zones and contributing to an increase in seepage, which is managed as noted above by the use of HDH's and piezometers.

General orientation of groundwater flow contours mimic the topography of the site as groundwater flows from the highest to lowest areas. Throughout most of the Mine area the groundwater divides of each sub-basin approximately coincide with the surface water divides. In the lower Dublin Gulch valley the groundwater divide

between the Upper Eagle Creek and Dublin Gulch basins when in the placer tailings is not as clearly defined due to the artificial depositional nature of deposits, and the construction and operation of Ditch B, which due to its lined nature has reduced the quantity of recharge that formerly came from Eagle Creek. Nevertheless, groundwater levels have been observed in the Dublin Gulch valley to be close to the surface (seepage emanating in deeper cut sections), with the highest levels occurring during freshet.

Groundwater recharge occurs at higher elevations throughout the Dublin Gulch-Eagle Creek drainage basin and ultimately discharges to surface water (in some cases as seeps and springs) at lower elevations in the valley or directly to surface streams, or ultimately into Haggart Creek. The main groundwater flow in conjunction with the highest groundwater elevations is expected to occur during the snowmelt in late spring (i.e., May to June) after thawing of the shallow sediment.

Data from nested well pairs or vibrating wire piezometer nests indicate upward or near neutral gradients in the lower Dublin Gulch valley and a mix of near neutral, downward and upward gradients in the upper reaches of Bawn Boy or in the Open Pit area. In some cases, gradient plots indicate both positive and negative gradients exist within the same profile, which may be due to anisotropy within the bedrock, and/or possible fracture controls on groundwater flow.

3.5.4 Surface Water - Groundwater Connectivity

Streamflow is generally composed of rainfall runoff and groundwater base flow. Groundwater contributes to stream flows where the groundwater table elevation intersects the ground surface. Typically, these intersections are located in stream channel inverts (e.g., there are several seeps that intersect with the Bawn Boy Gulch indicating the locations of the intersection with the bedrock groundwater table; also, the former Eagle Pup – now below the EP WRSA - appeared in mid-valley where the valley was well confined by bedrock); however, they also appear as seepage from slopes within the placer deposits of the lower Dublin Gulch valley. Groundwater from the lower Dublin Gulch valley likely contributes a measurable portion of the baseflow to Haggart Creek. The baseflow contributions to the streams maintain flow in the larger creeks during the drier months of the year (including winter flows).

3.5.5 Groundwater Flow Properties

Estimates of hydraulic conductivity in the overburden materials are based on 12 recovery tests carried out in colluvium, till, placer, and fluvial materials and three pumping tests conducted in the lower Dublin Gulch valley aquifer. Results for all testing range from 4×10^{-7} to 4×10^{-3} metres per second (m/s) at depths less than 35 m below ground. The hydraulic conductivity of the colluvial, alluvial, and till deposits was generally higher than that of the placer material, and also higher than the bedrock.

The bedrock hydraulic conductivity dataset includes over 80 packer tests and recovery tests conducted in over 50 boreholes and six pumping tests. Results of the pumping tests are typically considered to be more representative of the larger scale (bulk) hydraulic conductivity of the rock mass. Results of the 1996 pumping tests conducted at depths less than 55 m yielded hydraulic conductivity values ranging from 3×10^{-7} m/s to 5×10^{-7} m/s. Mean results of the two pumping tests conducted in bedrock in 2011 were 8×10^{-6} m/s in the lower valley and 9×10^{-8} m/s in the Open Pit area at depths up to 100 m and 140 m below ground, respectively. Results from the 2012 testing in the lower Dublin Gulch valley bedrock aquifer are about an order of magnitude higher (9.0×10^{-5} m/s) than results from 2011 testing; however, these results are specific to an 18 m thick zone targeted by the well, whereas the 2011 well was tested over a thicker (37 m) zone.

Generally, the hydraulic conductivity of the intrusive units and metasediments is similar and tends to decrease with depth, although considerable variation in results is apparent for each unit at any given depth. The general trend of decreasing hydraulic conductivity is common in bedrock settings as described by Rutqvist and Stephansson (2003).

3.5.6 Groundwater Quality

3.5.6.1 General Characterization

Groundwater quality data has been previously summarized in Stantec (2012b), which includes the most comprehensive data summary of 1996-2011 data, and BGC (2013a) which provides an update through 2012. Further, a comprehensive statistical characterization of background groundwater quality was completed by CoreGeo/Watterson (2017) in accordance with Clause 158 of QZ14-041. The assessment included a statistical analysis of all available groundwater quality data from the Mine area up through 2015. Since 2017, groundwater data have been collected as part of the EMSAMP and have reported on in each Annual Report.

The data suggests that the chemical composition of groundwater in the Mine area depends on the local and up-gradient rock-types. Groundwater quality data have been collected for many areas of the site including in Eagle Pup, Dublin, Suttles, Ann, Stewart, Olive, Bawn Boy and Platinum Gulches. The parameters analyzed included dissolved and total metals, nutrients, anions and other general parameters.

The groundwater samples were classified based on their major ion chemical composition, taking into account the major anions and cations. Calcium is the dominating cation in most groundwater samples from the site; however, in some sampling locations magnesium concentrations exceeded calcium. Carbonate was the dominating anion in all samples and was particularly high in some samples.

The following parameters from the naturally occurring hydrogeologic environment (baseline) exceeded the Canadian Council of Ministers for the Environment (CCME) and/or Contaminated Sites Regulation (CSR) guidance parameters in the Mine area: aluminum, arsenic, cadmium, copper, iron, lead, molybdenum, nickel, selenium, silver, and/or zinc. The CSR guideline values apply to both surface and groundwater, whereas the CCME guidelines only apply to surface water. However, as groundwater ultimately discharges to surface water bodies, the CCME guideline values are included here for reference.

Comparison of naturally occurring (baseline) groundwater quality data to current Yukon CSR AW standards (for protection of freshwater aquatic life) identified dissolved arsenic exceedances in all Mine sub basins. Arsenic concentrations in Ann Gulch, Suttles Gulch and Eagle Pup were 3 to 70 times higher than the CSR AW standard; whereas, arsenic concentrations in Platinum Gulch were 160 to 200 times higher than the CSR AW standard.

The highest dissolved arsenic concentrations reported in the Mine area occurred consistently in Platinum Gulch and ranged between 8 and 10 mg/L. These concentrations were approximately two times higher than dissolved arsenic values reported in a well in Dublin Gulch and approximately 10 to 100 times higher than concentrations reported in all other Mine sub-basins. No discernible correlations were interpreted between dissolved metals and geological strata. CSR AW dissolved arsenic exceedances were reported in monitoring wells screened in both unconsolidated sediments and bedrock.

The exceedances do not imply that the groundwater at the site is currently contaminated; only that the natural background concentrations of these parameters are higher than typically found in other natural sites in Canada and merely reflect the natural geologic and hydrogeologic conditions within these specific areas of the Mine area.

Comparison of the multiple years of groundwater data indicated that groundwater quality parameters were generally in the same range and that seasonal trends were not apparent over the years sampled up until operations began.

3.5.6.2 2017 Statistical Characterization of Baseline Groundwater Data

In keeping with the rationale described within the Reasons for Decision document issued for QZ14-041, and the methods described within CSR Protocol No. 10, background groundwater quality values at the 95th percentile were determined. Also, to help characterize the data across the site, groundwater quality data are presented and described by sub-basin and on a site-wide basis.

The following points summarize the results and conclusions of the statistical characterization:

- The quality and character of groundwater data (in terms of spatial coverage, multiple sampling events over a range of seasons and times of the year, consistency in sampling technique and analytical laboratory) meets or exceeds the requirements established in Protocol No. 10, where applicable.
- Stantec (2012b) and BGC (2013a) concluded that, in general, there were no discernible effects from well completion zone or seasonality in the data.
- Background concentration calculation and presentation methods are intended to illustrate groundwater quality variation at the site and to provide a baseline for future evaluation of groundwater data.
- Background POI concentrations (95th percentiles) demonstrated a high degree of spatial variability at the sub-basin and site-wide scales.
- Except for cyanide during the 1995-96 sampling events, the site-wide background concentrations of all general chemistry parameters did not exceed applicable CCME-FAL guideline values for these parameters.
- Although site-wide background calculations may provide a useful overall reference, significant variation in background concentrations between sub-basins for some elements indicates that the site-wide background values may not be the best representative value in all situations.
- A comparison between total and dissolved background concentrations demonstrated the role that turbidity and TSS has on the overall sample results, especially when TSS is greater than 100 NTU for the common rock forming elements (i.e., aluminum, iron). For the most part, total water chemistry data was suitable to support background parameter calculations; however, where wells produce samples with elevated turbidity or TSS, dissolved parameters may provide a better comparison with guidelines especially with respect to toxicity for aquatic life.

3.5.6.3 Groundwater Quality Monitoring

The groundwater quality monitoring program has been undertaken (as part of the EMSAMP) in conjunction with the groundwater quantity program with water quality samples taken on a quarterly basis. The results of the program are reported yearly in the Annual Report.

The discussions on groundwater quality in the Annual Reports are generally associated with four key spatial areas that align with the major facility footprints that include: HLF (Ann Gulch valley) and Events Pond, the LDSP area (or lower Dublin Gulch valley), the Platinum Gulch WRSA (or Platinum Gulch valley) and the Eagle Pup WRSA (or Eagle Pup valley), and a fifth key area (Bawn Boy Gulch) in the upper Dublin Gulch headwaters. Key

parameters of concern have been identified in previous reports (Stantec 2010; Stantec 2011, CoreGeo 2017, and in the Annual Reports for 2020, 2021, 2022 and 2023). They include: pH, aluminum, arsenic, cadmium, copper, lead, iron and selenium.

The following summary highlights some of the important observations identified in the 2022 Annual Report regarding potential trends for each of the four areas (only possible trends are discussed). Refer to figures in the 2022 Annual Report for the most up-to-date summaries and depictions of concentrations over time for the key parameters.

Heap Leach Facility (Ann Gulch valley) and the Events Pond

While there is fluctuation in values for all parameters, at this time there are no meaningful long-term increasing or decreasing trends in values for any of the parameters, although in some instances (e.g., Cd and Pb concentrations decreasing in MW19-DG6Ra perhaps due to a longer period to fully develop the wells, and Se concentrations increasing in MW19-HLF1b) there appear to be some minor short-term trends, which require additional years of monitoring to validate.

Parameter observations include the following:

- While there is fluctuation in values for all parameters, at this time there are no meaningful long-term increasing or decreasing trends in values for any of the parameters, although in some instances (e.g., Cd and Pb concentrations decreasing in MW19-DG6Ra perhaps due to a longer period to fully develop the wells, and Se concentrations increasing in MW19-HLF1b) there appear to be some minor short-term trends, which require additional years of monitoring to validate.
- pH has remained neutral to slightly basic for the duration of the monitoring program except MW19-EVP2b and MW22-HLF3b, which at times were slightly acidic. MW19-EVP2b and MW19-DG6Ra show the greatest variability.
- Aluminum levels across all wells ranged almost four orders of magnitude. However, for each well, fluctuations generally remained within one or two orders of magnitude.
- Arsenic levels are relatively stable with the varying concentrations between wells: MW19-DG6Ra and MW19-DG6Rb are all over 1mg/L arsenic, while MW10-AG6, MW10-AG3a, MW22-AG6aR, MW19-HLF1b, MW22-HLF2a and MW22-HLF4b have much lower concentrations (0.001 – 0.1 mg/L). The concentrations at MW19-EVP2b, MW22-HLF2b, MW22-AG6b, and MW22-HLF3b are between these two groups, with MW22-HLF4a much lower at 0.0001 mg/L and trending upward. There is a slight decreasing trend for MW19-HLF1b.
- For all the wells cadmium concentrations fluctuate between two and three orders of magnitude, while some individual wells exhibit less overall fluctuation. Cadmium was often reported at less than the detection limit for some of the wells. MW19-HLF1b and MW19-EVP2b have exhibited a decreasing trend (to the method detection limit) over time.
- Copper concentrations at all wells have a variability of approximately two to three orders of magnitude over time, with some wells with only one order of magnitude variability, while many samples were at or near the method detection limit.
- There have been zero instances of cyanide for any wells in this area. For 2023, lab results from all wells indicate concentrations below the detection limit of 0.0050 mg/L.

Section 3 Environmental Conditions

- Iron has overall high variability among all well locations (between four and five orders of magnitude), but individual wells have very consistent results over time.
- Except for MW19-EVP2b (with almost three orders of magnitude variability), lead concentrations for each well generally fluctuate only one order of magnitude and concentrations are often close to or at the MDL. MW19-EVP2b appears to demonstrate a decreasing trend since installation, which may reflect that it took a couple years to become fully developed.
- For all the wells, selenium concentrations fluctuate within two orders of magnitude. Most of the wells exhibit relatively stable conditions, some recording values at the method detection limit. MW19-HLF1b has shown an increasing trend over time.
- Except for a few anomalous increases in mercury concentrations (between 0.0001 to 0.00001 mg/L), all wells were slightly above the MDL with a decreasing trend to less than the MDL.
- Zinc concentrations show an overall moderate variability among wells of three orders of magnitude. Wells installed in 2019 indicate decreasing to stable concentrations over time, while wells installed in 2022 demonstrate minor short-term trends, which require additional years of monitoring to validate.
- Across all wells, chromium, fluoride, and silver concentrations fluctuate only one order of magnitude and are generally stable at individual wells.
- Uranium concentrations vary up to three orders of magnitude for all wells, with individual wells showing generally stable to slightly decreasing or increasing concentrations.

Lower Dublin South Pond Area (Lower Dublin Gulch Valley)

Groundwater data for the well network in the Lower Dublin Gulch drainage (which is the location of the Lower Dublin South Pond) is provided below. The wells considered include BH-BGC11-72, BH-BGC11-74, MW10-OBS1, MW19-LDSP2a/b and MW18-DG2R. The data set for this area consists of groundwater quality data from 2017 through 2023. MW10-OBS1 was replaced with MW19-LDSP2a in 2019 and is no longer monitored. MW18-LDSP1 continues to be monitored on a quarterly basis but has had insufficient water in the well to collect samples.

Parameter observations include the following:

- pH is consistently neutral to slightly basic across all wells. MW19-LDSP2a/b and MW18-DG2R all had similar ranges of pH values throughout 2023.
- MW19-LDSP2b and BH-BGC11-72 had anomalously high aluminum concentrations in 2019. Except for 2019, all wells have exhibited a low variability of aluminum concentrations (within 0.001 to 0.1 mg/L or one to two orders of magnitude) throughout 2023. Stations show similar trends throughout each quarterly sampling event.
- Arsenic concentrations range four orders of magnitude for the LDSP area wells. However, from 2020-2023, concentrations have been very consistent for BH-BGC11-72, BH-BGC11-74 and MW19-LDSP2a/b. Concentrations at MW18-DG2R were generally higher (3.24 to 4.48 mg/L) for the period 2020-2023.
- Cadmium concentrations range from 0.000001 mg/L to 0.001 mg/L across all stations. Over the data collection period, there appears to be a downward trend to the MDL in cadmium concentrations for all stations.

- Taken collectively, copper concentrations have ranged over three orders of magnitude with some seasonal variation, trending near or below the MDL (0.0002mg/L).
- Iron concentrations have ranged over four orders of magnitude for the wells in this area. However, since 2020, iron concentrations at BH-BGC11-72, BH-BGC11-74 and MW19-LDSP2a have had very consistent values over the monitoring period, with no discernable upwards or downward trends.
- Lead concentrations have displayed variability over the entire dataset but appear to have stabilized since 2019. Of the five wells sampled in 2023, there was an anomalous increase from one sampling event at MW19-LDSP2b.
- Selenium concentrations have exhibited between one and two orders of magnitude variability for wells in this area. Concentrations were stable for 2023 samples, remaining at or below MDL throughout the year. MW19-LDSP2a was the only exception, exhibiting general concentrations closer to 0.001 mg/L.
- Across all wells, mercury concentrations have trended downwards since 2019 and have stabilized at or below the MDL.
- There is minimal variability of two orders of magnitude in zinc concentrations between all wells, generally trending downwards from 2019. For the 2023 period, concentrations were generally stable with one anomalous increase observed at BH-BGC11-74.
- Chromium concentrations have remained at or below MDL from 2021 onwards.
- Fluoride concentrations fluctuate only one order of magnitude and are generally stable at individual wells.
- Across all wells, silver concentrations have shown a decreasing trend from 2019 onward and have remained at or below MDL from 2022-2023.
- Uranium concentrations fluctuate only one order of magnitude and are generally stable. MW19-LDSP2b shows a slight increasing trend.

Platinum Gulch WRSA (Platinum Gulch Valley)

Groundwater data for the well network in the Platinum Gulch drainage, including wells in the Land Treatment Facility (LTF) area, is provided in the figures below. The data set for this area consists of groundwater quality data from 2019 through 2023. Wells were monitored quarterly in 2023 and include MW10-PG1, MW19-PGW1a, MW22-PGW1bR, MW22-LPH1b, and MW22-LPH2b.

The LTF area wells MW22-LPH1b and MW22-LPH2b were developed in Q2 2023 and then monitored accordingly, however both wells were damaged during the year due to wildfire mitigation efforts or equipment loss down the well and will need to be re-drilled in 2024, with further data collection requirements to discern any trends.

Parameter observations include the following:

- pH has remained neutral to slightly basic over the last five years of data collected for both MW10-PG1 and MW19-PGW1a. Both stations have similar trendlines over the collection period. The other three wells (MW22-PGW1bR, MW22-LPH1b and MW22-LPH2b) have not been installed long enough to discern trends, but the observed pH values were all within an expected range (7.5 to 8.2).
- Aluminum concentrations at MW10-PG1 and MW19-PGW1a have a range of approximately one order of magnitude from 2019 to present with no increasing or decreasing trends. MW22-PGW1bR requires further data collection to identify any trends.

Section 3 Environmental Conditions

- Arsenic concentrations at MW10-PG1 and MW19-PGW1a appear relatively stable with one spike recorded in Q2 2022 at MW19-PGW1a. MW10-PG1 continues to exhibit the highest arsenic concentrations of all wells monitored on the project site, fluctuating from 8-9 mg/L throughout the period. Concentrations at MW22-PGW1bR show a decreasing trend during 2023 but will require further data collection to validate.
- Cadmium concentrations at MW10-PG1 and MW19-PGW1A show a stable trend since April 2020. Further data collection is required at MW22-PGW1bR, MW22-LPH1b and MW22-LPH2b before any trends can be identified.
- Copper concentrations at MW10-PG1 and MW19-PGW1a have showed relatively stable values since 2019, with both wells being within the range of 0.0002-0.004 mg/L. Remaining area wells were at or near the MDL for samples taken in 2023.
- Iron concentrations remained relatively stable for 2023 except for a spike in the MW22-PGW1bR sample collected in Q4 2023. This was one order of magnitude greater than the previous three samples; however further monitoring will be required to discern any trends for this well. Prior to 2023, concentrations in the two wells (MW10-PG1 and MW19-PGW1a) were relatively constant (within ~one order of magnitude) except for a few occurrences, which appear to be anomalies.
- Lead concentrations across all wells were stable throughout 2023 although there is a discernable increase of one order of magnitude at MW10-PG1 from 2022 to 2023, although the increase did not exceed historic values from 2019.
- Selenium concentrations for 2023 were relatively stable, and within the range of historical data. MW19-PGW1a displays a relatively flat trend (except for an anomalously low value on April 26, 2022, coinciding with the spikes in As and Al). Sample results for all wells were within two orders of magnitude of each other.
- Mercury concentrations at all wells remained at or below MDL for the reporting period.
- MW10-PG1 and MW19-PGW1a zinc concentrations remained consistent with previous year sample results while there is a discernible increase from Q1 onward for MW22-PGW1bR. Further monitoring is required to validate any trends at this location. MW10-PG1 has showed a steady decline of over an order of magnitude since November 2020 after exhibiting a two order of magnitude increase over the first two years of monitoring. Further, while MW19-PGW1a did not exhibit the increase that MW10-PG1 did, this well has showed a steady decline (similar in gradient to the decline in MW10-PG1) from about 0.02 mg/L to about 0.003 mg/L.
- Chromium and silver concentrations remained at or below the MDL (0.00025 mg/L) across all wells except for MW10-PG1 and MW22-LPH1b,
- Fluoride and uranium concentrations were relatively stable across all wells for the reporting period, with only one order of magnitude (or less) difference between all wells.

Eagle Pup WRSA (Eagle Pup Valley)

Groundwater data for the wells in the Eagle Pup drainage is provided in Figure 3.4-14 through Figure 3.4-17. Information has been gathered for this area at two locations since 2009 (MW96-13a and MW95-151¹). MW19-EPW1a and MW19-EPW1b were installed in 2019. MW19-EPW1b was replaced by MW22-EPW1bR and MW22-151a was installed in 2022.

Parameter observations include the following:

- pH in the Eagle Pup drainage is neutral to slightly basic.
- Aluminum concentrations have fluctuated within less than two orders of magnitude for all wells, except for an anomalous spike in MW93-13a in 2014.
- Except for the period just after installation in MW96-13a, arsenic concentrations have had minor variability within less than one order of magnitude for each well.
- Cadmium concentrations for samples taken in 2023 are all within one order of magnitude with some wells (MW95-151 and MW22-EPW1bR) close to or at MDL. Concentrations in MW19-EPW1a appear to have stabilized to less than 0.0001 mg/L after initial higher concentrations just after installation.
- Of the four wells sampled in 2023, copper concentrations are within two orders of magnitude. There is an overall decreasing trend over an order of magnitude in MW19-EPW1a since installation. At the same time, the couplet deeper well (MW19-EPW1b) exhibited an increasing trend until it was decommissioned in early 2022. Concentrations in the replacement well MW22-EPW1b were lower and did not continue this trend.
- Iron concentrations have shown a high variability over the monitoring period and have varied up to three orders of magnitude for all the wells. While MW95-151 has exhibited an overall increasing trend since 2009, concentrations have decreased somewhat over the last year. Similarly, MW96-13a exhibited an order of magnitude increase until it was decommissioned in 2021. MW19-EPW1a has shown a slight increase in 2023 compared to the downward trend observed 2020-2022.
- For all wells, lead concentrations display trends towards detection limits since the end of 2022. The relatively high lead concentrations observed in MW19-EPW1a appear to have stabilized at concentrations two orders of magnitude lower than that observed just after well installation.
- For all wells, selenium concentrations have varied within two orders of magnitude. Concentrations at MW96-13a were measured at or near to the detection limit from 2009-2020 until the well was decommissioned. Concentrations of selenium at MW22-EPW1bR were at or below MDL for samples taken in 2023. All other active sites remain around one order of magnitude from one another, with MW19-EPW1a showing a slight increase over the last two sample events.
- Mercury concentrations at all wells have remained at or below detection limits, except for an anomalous spike at MW19-EPW1a in Q4 2023.
- For all wells, zinc concentrations since 2019 have varied within approximately two orders of magnitude. Data from the older wells MW95-151 and MW96-13a suggest an overall decreasing trend since

¹ MW95-151 was incorrectly labeled MW96-15b in previous years.

installation, while the newer wells (since 2019) exhibit high variability between sampling events without any discernible trends.

- All wells indicate consistent chromium and silver concentrations close to or at the MDL.
- Fluoride and uranium concentrations for all wells remain within one order of magnitude and are consistent over time.

Bawn Boy Gulch (Upper Dublin Gulch Headwaters Area)

Beginning in 2019, efforts to gather information on groundwater quality have focused on the Bawn Boy Gulch drainage area, where a single monitoring well (MW96-9b) has been in operation since its installation in 1996. This well has been periodically monitored since installation, with continuous water level recording beginning in 2011 (except for a brief period in 2017-2018). Data for this well is provided below.

- The pH level in MW96-9b is consistently neutral to slightly basic, as confirmed by field measurements that show consistency within one standard unit (between pH 6.7-7.5).
- Aluminum concentrations have varied two orders of magnitude since 2019, with an overall stable concentration.
- Arsenic concentrations have been remarkably consistent ranging between 0.05 to 0.16 mg/L, decreasing since 2019 to an overall stable trend from 2020-2023.
- Except for the first sample in early 2019, cadmium concentrations are within less than one order of magnitude.
- Copper concentrations steadily declined since 2019 and remained at or below MDL for all samples taken in 2023.
- Iron concentrations were initially relatively high (~3 mg/L) but have remained much lower over subsequent years, being either at or slightly above detection limits.
- Similarly to iron, lead concentrations were initially relatively high (upwards to 0.004 mg/L) but have since been at the MDL or slightly higher in subsequent samples.
- Selenium concentrations have remained relatively constant since 2019 with a slight decreasing trend from 2022-2023.
- Mercury concentrations were relatively higher during the initial sampling event in 2019 but have trended down to detection limits or lower in recent years.
- Zinc concentrations showed an initial decreasing trend from the onset of sampling until Q4 2021 where concentrations peaked at 0.00012 mg/L in Q2 2022, before exhibiting a decreasing trend over the last six sampling events.
- Since the onset of sampling, chromium concentrations have been relatively stable at or slightly above MDL.
- Fluoride concentrations have been very stable since the onset of sampling, ranging between 0.03-0.04 mg/L.
- Silver concentrations have trended downward to detection limits or lower since the onset of sampling.

- Uranium concentrations exhibit a slight overall downward trend since 2019, with average concentrations being 0.0002 mg/L.

4 DESIGN BASIS AND CRITERIA

4.1 STORM WATER DESIGN CRITERIA

For the purpose of this Plan, the Mine area had been subdivided into a number of hydrologic watersheds and sub-watersheds, as shown on Figure 4.1-1. These watershed boundaries shown in the figure are based on the proposed end of mine topography during the design phase. To ensure that the corresponding conveyance and storage structures were capable of routing runoff during the entire life of the Mine, they were sized to their largest respective contributing area.

A risk-based approach was used to select appropriate design storm events for water management facilities. This approach weighs the likelihood of failure, versus the consequence of failure, on a case-specific basis. Design storm events are developed by assessing the annual recurrence of precipitation events of a given magnitude, as described in Section 3.

Design storm events were used as input parameters in most rainfall-runoff type storm water models (e.g., HEC-HMS, PCSWMM and, TR-55). Design criteria for various design elements are listed in Table 4.1-1.

Table 4.1-1: Design Criteria

Infrastructure Element	Design Element	Design Basis Criteria
Unlined Diversion or Collection Ditches	Design Storm Event	1 in 10-year, 24-hour for capacity and 1 in 100-year for armouring
	Maximum Depth (mm): Type 1 or 2	300
	Minimum Width (mm): Type 2	500
	Minimum Grade (%): Type 1 or 2	1.00
	Maximum Grade (%): Type 1 or 2	1.70
	Maximum Side Slopes: Type 1 or 2	3H:1V
	Maximum Velocity (m/s): Type 1 or 2	1.5
Lined Diversion or Collection Ditches	Design Storm Event	1 in 10-year, 24-hour for capacity and 1 in 100-year for armouring
	Design Storm Event (above major infrastructure)	1 in 100-year
	Maximum Depth (mm)	500
	Minimum Grade (%): Type 3 / Type 4	1.00 / 0.50
	Maximum Grade (%): Type 3 / Type 4	4.5 / 15
	Maximum Side Slopes: Type 3 / Type 4	2.5H:1V / 1H:1V
	Maximum Velocity (m/s): Type 3 / Type 4	2.33 / 4.0
Pipes	Design Storm Event	1 in 10-year, 24-hour
Culverts	Minimum Diameter (mm)	750
	Design Storm Event (Areas < 1 ha)	1 in 10-year, 24-hour
	Design Storm Event (Areas > 1 ha)	1 in 100-year, 24-hour
	Design Storm Event (at stream conveyances)	1 in 200-year, 24-hour
	Design Storm Event (downstream of the Lower Dublin South Pond)	1 in 1000-year, 24-hour

Infrastructure Element	Design Element	Design Basis Criteria
	Maximum HW/Diameter Ratio	2.0 for less than 1.0 m 1.5 for greater than 1.0 m
	Minimum Grade (%)	0.5
	Minimum Velocity (m/s)	1.0
	Maximum Velocity (m/s)	4.0
Temporary Sediment Control Ponds and Exfiltration Areas	Design Storm Event (storage)	1 in 10-year, 24-hour
	Design Storm Event (overflow spillway)	1 in 100-year, 24-hour
	Depth Requirements (m):	
	Minimum Dead Storage (sediment)	0.5
	Maximum Dead Storage (sediment)	50% of Total Depth
	Minimum Live Storage (liquid)	1.5
Permanent Sediment Control Ponds	Minimum Freeboard (100-year event)	0.5
	Design Storm Event (storage)	1 in 10-year, 24-hour
	Design Storm Event (overflow spillway)	1 in 200-year, 24-hour
	Design Storm Event (overflow spillway – dam)	1 in 1000-year, 24-hour
	Depth Requirements (m):	
	Minimum Dead Storage (sediment)	0.5
	Maximum Dead Storage (sediment)	50% of Total Depth
	Minimum Live Storage (liquid)	1.5
Minimum Freeboard (200-year event)	0.5	
	Dewatering (pumping capability)	Full Dewater in 24 hours

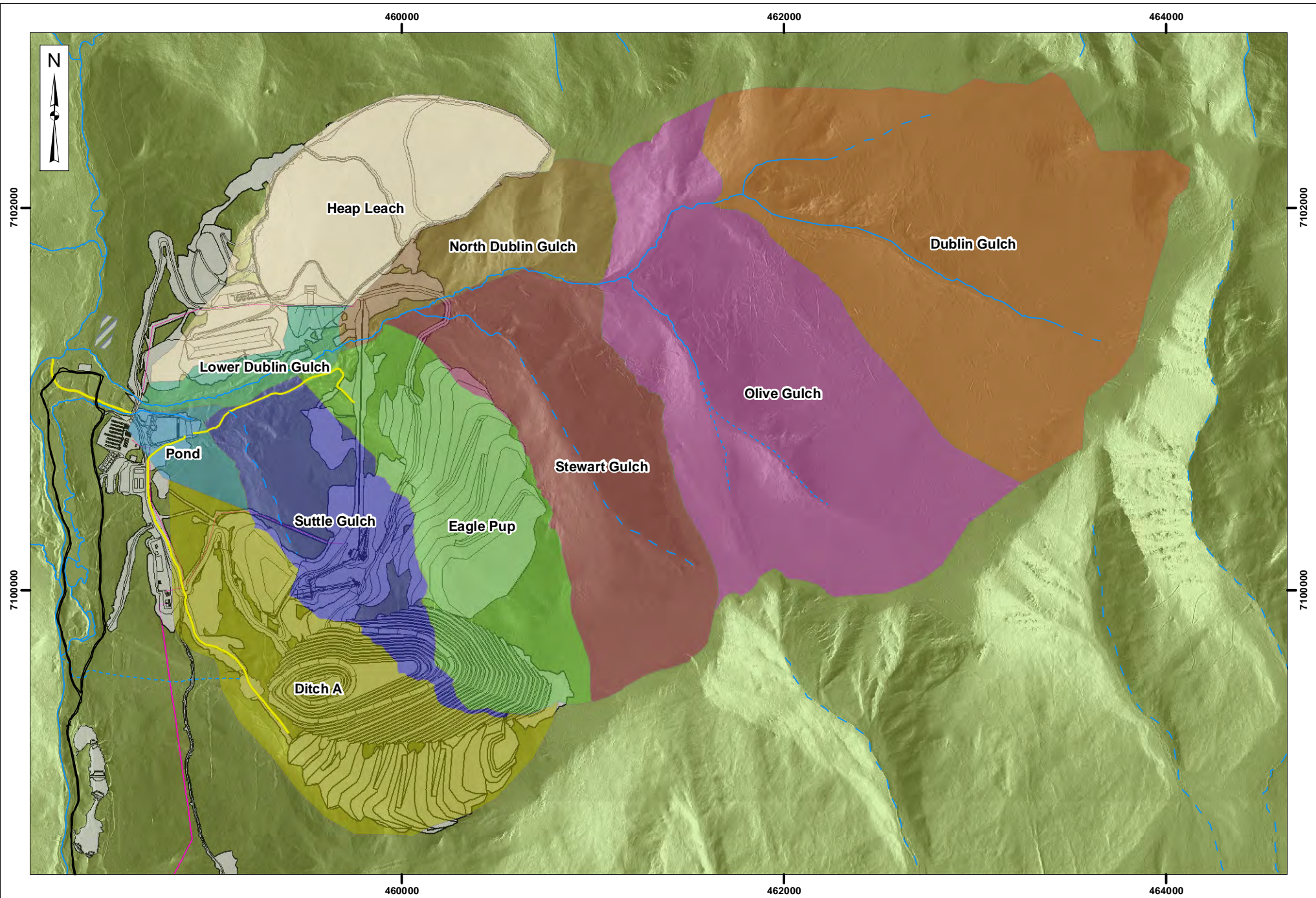

Legend:

- Facility
- Site Power
- Watercourse - Perennial
- - - Watercourse - Ephemeral
- · · Watercourse - Intermittent
- ▨ Reserved Area
- Major Ditch

VICTORIA
GOLD CORP

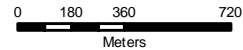

Projection:

NAD 83 UTM
Zone 8

Date:

2023-12-30

Drawn By:

HC

Figure:

4.1-1

**EAGLE GOLD MINE
YUKON TERRITORY**

**Overview Plan
Watershed Areas**

4.2 SEDIMENT AND CONTROL EROSION

Sediment and erosion control measures are implemented and maintained to prevent the discharge of sediment-laden water to the receiving environment. The BMPs described below are shown on Figure 4.2-1 to Figure 4.2-3 and were utilized during construction and continue to be required during operations. Implementation of BMPs is described in Section 6.

4.2.1 Sediment and Erosion Sources

Activities that have the potential to result in erosion and sedimentation include the following.

- Vegetation clearing and topsoil stripping.
- Excavation, grading and filling.
- Stockpiling of topsoil and waste rock.
- Management of ice-rich material.
- Construction and maintenance of roads and infrastructure.

Potential effects from the above activities in the absence of planned mitigation measures include:

- Increased surface erosion from disturbed and rehabilitated areas
- Increased sediment load entering the natural water system
- Siltation or erosion of ditches, culverts, and watercourses
- Damage to existing roadways and embankments, i.e. rutting, scouring, or potholing

The Plan addresses the above potential hazards to ensure effective management of surface water and sediment-laden runoff. Sediment mobilization and erosion can best be minimized by using the following measures.

- Limiting the extent of land disturbance to the practical minimum
- Reducing water velocities across the ground using soil bioengineering, surface roughening, sediment logs, and re-contouring, particularly on exposed surfaces and in areas where water concentrates
- Concurrently reseeding disturbed land and constructing drainage controls to improve the stability of rehabilitated land
- Protecting natural drainages and watercourses by constructing appropriate sediment control devices such as collection and diversion ditches, sediment traps, in-channel energy dissipaters, and sediment basins
- Installing rock riprap, channel lining, sediment filters or other suitable measures in ditches on steep gradients, as required
- Restricting access to re-vegetated and stabilized areas
- Constructing collection and diversion ditches to intercept surface runoff
- Directing all sediment-laden runoff to the appropriate sediment control measure

- Constructing appropriate temporary BMP measures (e.g., silt fences, hay bales) downslope of disturbed sites (where more permanent sediment control measures are not appropriate, or in combination with more permanent measures)
- Implementing soil bioengineering techniques to contain sediment and enable disturbed surfaces to recover.

Installation of temporary erosion and sediment control features or “BMPs” is the first step towards controlling erosion and sedimentation. All temporary sediment and erosion control features will require regular maintenance and inspection after each significant rainfall. These temporary features will be removed after achieving soil and sediment stabilization. Typical sediment and erosion design elements and BMPs are described in the following section.

4.2.2 Best Management Practices

Erosion control BMPs reduce erosion by stabilizing exposed soil or reducing surface runoff flow velocity. There are generally two types of erosion control BMPs:

- Source control BMPs for protection of exposed surfaces, and
- Conveyance BMPs for control of runoff and reduction/capture of sediment.

Descriptions of the planned BMPs are provided below.

4.2.2.1 Vegetation Management

Natural vegetation is one of the best and most cost-effective methods of reducing the potential for erosion and sedimentation. Vegetation keeps soil secure, and leaves and ground cover absorb raindrop velocities. In order to preserve vegetation, “no-entry” vegetation buffers are utilized to prevent excess clearing, particularly around water bodies, prior to clearing vegetation from surrounding areas. When preserving natural vegetation is not a viable option, cleared areas that will not include infrastructure will be re-seeded as soon as practical.

4.2.2.2 Soil Bioengineering

Soil bioengineering is the use of plant materials to perform engineering functions such as bank protection, erosion protection, drainage, and slope stabilization (Polster 2002). Some typical techniques include:

- Sediment log fences
- Live bank protection
- Live palisades

Sediment log fences are used on over-steepened slopes where the incline prevents successful growth of vegetation. Sediment logs are placed on the slopes to create terraces, which slows the velocity of water, and holds the soil in place in order to encourage vegetation growth.

Live bank protection is generally used in streams for habitat restoration, but the technique can be transferred to constructed ditches. Sediment log fences using cut plugs and live cuttings are installed on the banks of the ditch, which become stabilized once the live cuttings sprout and grow.

The live palisades technique involves installing large cottonwood (poplar) posts in trenches adjacent to eroding stream beds where the natural vegetation has been compromised. The cottonwood will root along its entire buried length producing a dense cylinder of roots.

These techniques prevent the creation of smooth, hard surfaces, which tend to encourage increased velocities and thus increased erosion potential. USDA (1992) provides useful application and construction guidelines for various bioengineering techniques.

4.2.2.3 Mulching

Mulching is the application of a uniform protective layer of straw, wood fiber, wood chips, or other acceptable material on, or incorporated into, the soil surface of a seeded area to allow for the immediate protection of the seed bed. The purpose of mulching is to protect the soil surface from the forces of raindrop impact and overland flow, foster the growth of vegetation, increase infiltration, reduce evaporation, insulate the soil, and suppress weed growth. Mulching also helps hold fertilizer, seed, and topsoil in place in the presence of wind, rain, and runoff, while reducing the need for watering. Mulching has been used to minimize permafrost thaw and to restore physical stability in some disturbed areas.

Mulching may also be utilized in areas that have been seeded either for temporary or permanent covers. There are two basic types of mulches: organic mulches and chemical mulches. Organic mulches may include straw, hay, wood fiber, wood chips and bark chips. This type of mulch is usually spread by hand or by machine (mulch blower) after seed, water, and fertilizer have been applied. Chemical mulches, also known as soil binders or tackifiers, are composed of a variety of synthetic materials, including emulsions or dispersions of vinyl compounds, rubber, asphalt, or plastics mixed with water. Chemical mulches are usually mixed with organic mulches as a tacking agent to aid in the stabilization process, and are not used as stand-alone mulch, except in cases where temporary dust and/or erosion control is required.

Hydroseeding, sometimes referred to as hydromulching, consists of mixing a tackifier, specified organic mulch, seed, water, and fertilizer together in a hydrosurry and spraying a layer of the mixture onto a surface or slope with hydraulic application equipment. The choice of materials for mulching will be based on soil conditions, season, type of vegetation, and the size of the area.

4.2.2.4 Rolled Erosion Control Products

Rolled erosion control products (RECP) are geosynthetic or organic materials composed of two layers of coarse mesh that contain a central layer of permeable fibers in between. These products take the form of flexible sheet materials that are often composed of organic materials that decompose over time. When intended for long-term use, RECPs are made from UV-stable synthetics such as polypropylene. RECPs may be used to cover unvegetated cut or fill slopes in order to provide erosion control when seeding or mulching alone is unsuccessful. RECP sheets must be anchored with special stakes or rocks and must be in direct, tight contact with the soil surface in order to perform effectively. RECP's have been used sparingly in specific areas to date.

4.2.2.5 Surface Roughening

Cut and fill slopes are typically roughened with tracked machinery or by other means, to reduce runoff velocity, increase infiltration, reduce erosion, and to aid in the establishment of vegetative cover. Roughening is typically carried out by a tracked machine moving up and down the slope, creating undulations on the soil surface parallel to the contour. This procedure is simple, inexpensive and provides immediate short-term erosion control for bare

soil, where vegetative cover is not yet established. Compared to hard, compacted smooth surfaces a rough soil surface provides more favorable moisture conditions, which will aid in seed germination. Surface roughening works best on flat and moderately sloped areas.

4.2.2.6 Re-contouring

Re-contouring the soil surface can also reduce the effect of erosion by shortening the length of the accumulation and movement of water as well as decreasing its slope. Creating undulations or troughs also reduces overland water movement velocity. These types of improvements are beneficial as they are easily planned and constructed on site. However, where implemented both surface roughening and re-contouring are considered only semi-permanent erosion control methods and more permanent structures will be needed over time.

4.2.2.7 Silt Fencing

Silt fencing is a perimeter control used to intercept sheet flow runoff and used in conjunction with other BMPs. Typical silt fencing comprises a geotextile fabric anchored to posts driven into the ground. Silt fencing promotes sediment control by filtering water that passes through the fabric and increases short term detention time, allowing suspended sediments to settle. A typical silt fence installation is shown on Figure 4.2-1.

Silt fences have been placed parallel to slope contours in key areas. Barrier locations were chosen based on site features and conditions (e.g., soil types, terrain features, and sensitive areas), design plans, existing and anticipated drainage courses, and other available erosion and sediment controls. Typical barrier sites are catch points beyond the toe of fill or on side slopes above waterways or drainage channels. Silt fences have not been used for wide low-flow, low-velocity drainage ways, for concentrated flows, in continuous flow streams, for flow diversion, or as check dams. Silt fencing has been installed per the manufacturer's specifications and as detailed on Figure 4.2-1.

Silt fencing conditions are typically inspected and maintained following major rainfall events. Proper installation and frequent maintenance is required for effective sediment control.

4.2.2.8 Temporary Sediment Traps and Sediment Basins

A sediment trap/basin is a temporary structure that is used to detain runoff from small drainage areas (generally less than 2 hectares [ha]) to allow sediment to settle out. Sediment traps/basins have been and will be located in areas where access can be maintained for sediment removal and proper disposal. A sediment trap/basin can be created by excavating a basin, utilizing an existing depression, or constructing a dam on a slight slope downward from the work area. Sediment-laden runoff from the disturbed site is conveyed to the trap/basin via ditches, slope drains, or diversion dikes. The trap/basin is a temporary measure and is to be maintained until the site is permanently protected against erosion by vegetation and/or structures.

Temporary sediment traps and sediment basins have been and will be constructed at the end of smaller collection ditches to detain sediment-laden runoff long enough to allow sediment to settle out. The size of the temporary sediment trap/basin is dependent on the ditch design flows. The exact locations and final geometry of the traps are field fitted to integrate with the terrain to minimize disturbance. The Site Services Manager or Technical Services Superintendent review and approve the sizing and location of these basins prior to construction with input from the Environmental Superintendent. The sediment traps/basins are inspected regularly. When the sediment trap/basin has accumulated sediment and/or debris, the traps are cleaned to restore design capacity.

Two sizes of sediment basins designated SB1 and SB2 have been developed for the site and used for different size drainage areas. The sizing and dimensions of the two sediment basins are summarized Table 4.2-1.

Table 4.2-1: Temporary Sediment Basin Design Specifications

	Sediment Basin size 1	Sediment Basin size 2
Drainage Area (hectares)	<1	1 - 2
Width (m)	10	12
Length (m)	20	25
Depth of Wet Storage (m)	1	1
Minimum Spillway Weir Length (m)	2	4

The width and length dimensions correspond to the top of the wet storage area, at the base of the outlet structure.

4.2.2.9 Filter Bags and Geotubes

Filter bags are generally constructed from a sturdy non-woven geotextile capable of filtering particles larger than 150 microns. Filter bags are typically installed at the discharge end of pumped diversions, via fabric flange fittings, to remove fine grained materials before discharging to the environment. These measures have not been utilized to date.

If and when used for fine grained materials, filter bags shall be installed on flat, stable, non-erodible foundations, or in well vegetated areas. The pumping rate shall be no greater than specified by the manufacturer. Discharge from filter bags will be routed to lined areas (i.e., rock aprons, riprap, etc.) to reduce water velocity and minimize erosion.

A smaller variety of filter bags, referred to as filter socks, can be installed on the discharge ends of gravity flow pipes, such as slope drains, to filter silt particles before discharging to the environment.

Filter bags shall be maintained in the following manner.

- Inspected daily for defects, rips, tears, sediment accumulation, and erosion of the surrounding area.
- When sediment fills one half of the volume of the filter bag, the filter bag shall be removed from service and replaced.

Spare bags shall be kept nearby to minimize time required to recommence pumping activities. Once the used bag is fully drained, the bag and its contents can be deposited in the reclamation material storage areas for use as cover materials during mine closure or disposed of in the on-site landfill.

Geotubes can be used as part of a dewatering system to separate and contain solids in sediment-laden water. The system is composed of a geosynthetic tube, which is available in various sizes, and an injection port. The sediment-laden water is pumped or directed via gravity into the geotube until it is full. Clean water drains through the pores of the engineered textile, which allows the solids to consolidate inside the geotube. Once the apparatus is full of solids, it can be disposed of at a landfill, or the solids can be removed and used on site.

4.2.2.10 Flocculants

The term flocculation is used to describe the aggregation of small particles clumping together and settling out of suspension. In sediment and erosion control applications, flocculation is achieved with the use of chemical or natural additives (e.g., corn starch, chitosan, guar gum). The flocculants accelerate the natural settling process

in sedimentation ponds as the sediment-laden water flows through the pond, and therefore the required pond detention time is reduced. Additionally, flocculants can be added at specific points along collection ditches to initiate the settling process prior to arrival at the water management pond. This system may be beneficial in steep topographic areas where:

- The calculated surface area for the design particle size is not practical
- Where the clay component is high, as clay soil types have a lower settling velocity than other particles.

If site conditions necessitate the use of flocculants, VGC will use only products from the high molecular weight anionic polyacrylamides (or PAMs) group of flocculants, and that are non-toxic to fish to settle sediment in sediment control ponds or sediment basins. There is a wide range of anionic PAMs available for water clarification and erosion control. The methods used to identify the flocculants to be used for this Mine are described in the Flocculant Use Plan (Appendix A).

4.2.2.11 Collection Ditches

Strategically placed ditches and runoff collection structures can help direct water movement, which in turn limits erosion. A collection ditch intercepts sediment-laden water runoff from disturbed areas and diverts it to a stabilized area where it can be effectively managed. Collection ditches are used to collect runoff and convey it to the appropriate sediment control measures. General locations and conditions include the following.

- Below disturbed existing slopes to divert sediment-laden water to control facilities.
- At or near the perimeter of a construction area to prevent sediment-laden runoff from leaving the site.
- Below disturbed areas before stabilization to prevent erosion.

Ditch designs have been based on steady, uniform flow analysis.

Two large collection ditches (Ditch A and Ditch B, see section 6.1.2) have been built at the downslope perimeter of development activities including the WRSAs, open pit and crushers, while smaller collection and diversion ditches have been used to direct flow to the main catchment ditches. Cut and fill slopes leave long runs of exposed soils that are prone to erosion. A ditch placed above the cut slope will intercept water and direct it to less erosion prone areas. Typical collection and diversion ditches (two types) are shown on Figure 4.2-3.

4.2.2.12 Diversion Ditches

Diversion ditches have been and will be constructed up-gradient of disturbed areas to intercept clean surface water runoff as practicable. A diversion ditch is a channel lined with vegetation, riprap, or other flexible, erosion resistant material. The main design considerations are the design flow and velocity of the water expected in the channel. All diversion ditches have been designed to carry the appropriate peak flow. All diversion ditches discharge through a stabilized outlet designed to handle the expected runoff velocities and flows from the ditch without scouring. The selection of a type of lining is based upon the design flow velocities.

4.2.2.13 Roadside Berms and Ditches

Major roads within the Mine footprint also include a safety berm and roadside ditch to maintain a safe and dry driving surface. Safety berms are constructed with locally sourced fill material and the roadside ditch is either cut into the existing topography or excavated in the fill surface of the road. Whilst these features are not constructed to specific water management criteria (as in the case of the berm the configuration is derived based on safety

requirements) these features act to support erosion and sediment control as they effectively channel surface runoff in local areas to low points of the road profile for exfiltration. Typical cross sections for haul and mine service roads are provided in Figure 4.2-4 and Figure 4.2-5.

4.2.2.14 Culverts

In general, while variations may occur due to site-specific conditions, culverts have been installed at a slope of 2% with an inflow along a smooth headwall. In some cases, a small energy dissipater or stilling basin is constructed upstream of each culvert to reduce sedimentation. The culverts in use consist of corrugated metal pipe or corrugated polyethylene tubing installed according to the manufacturer's specifications to accommodate the anticipated vehicle loading and to prevent crushing. Standard culvert details can be seen in Figure 4.2-1.

4.2.2.15 Exfiltration Areas

An exfiltration area is used to treat sediment-laden water by detention in an area that is not lined, and which allows the water to filter through the natural ground surface leaving the sediment behind. This process provides complete capture of the sediment as it filters the water only and does not allow for any additional outflows such as riser pipes and/or spillways, which are commonly used in sediment ponds/basins.

Where feasible, exfiltration areas have been designed to detain the 10-year 24-hour storm event. The hydraulic conductivity of surficial material on site ranges from 10^{-3} to 10^{-7} m/s. A value of 10^{-7} m/s is used for the design of the exfiltration areas.

Section 4 Design Basis and Criteria

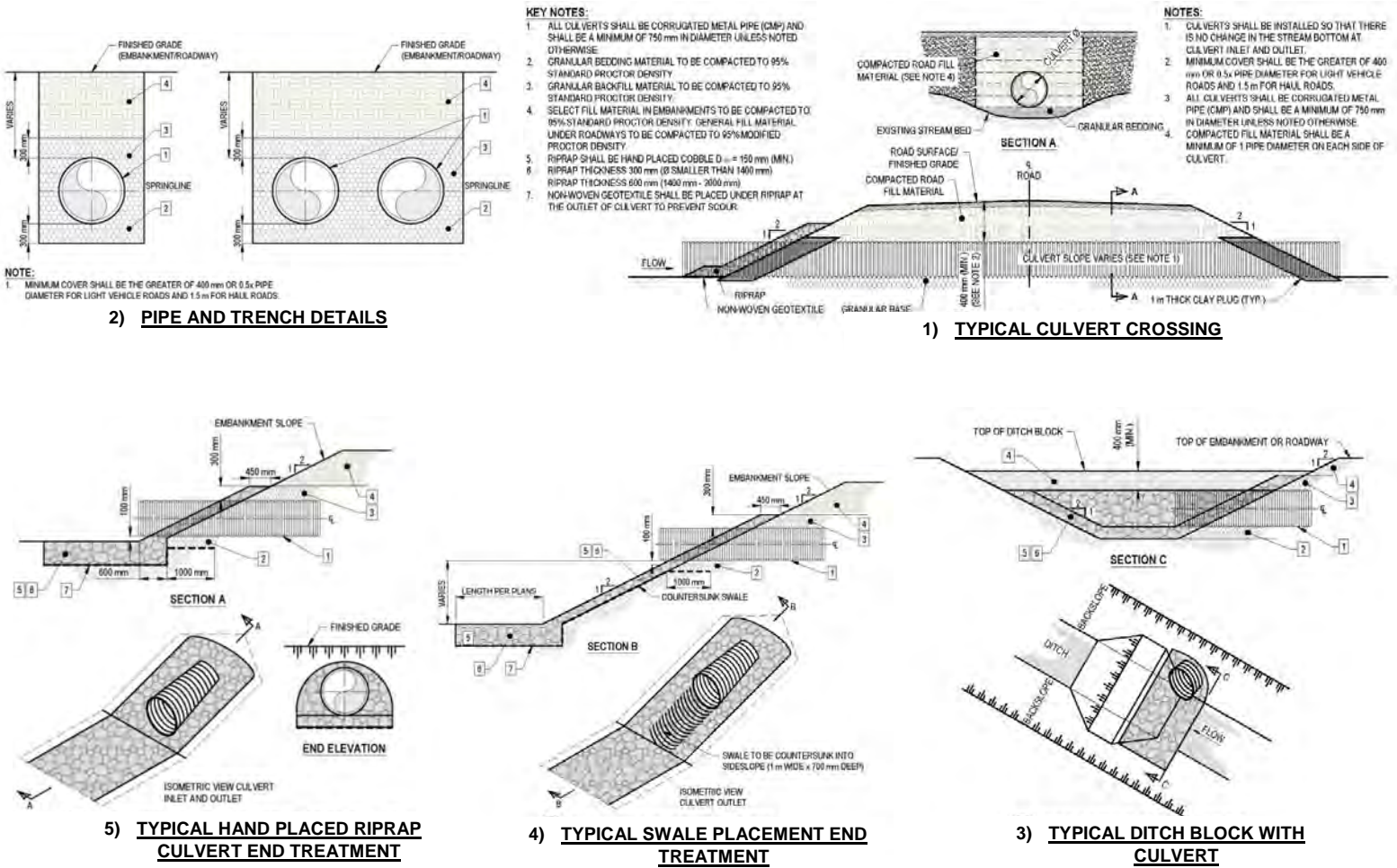
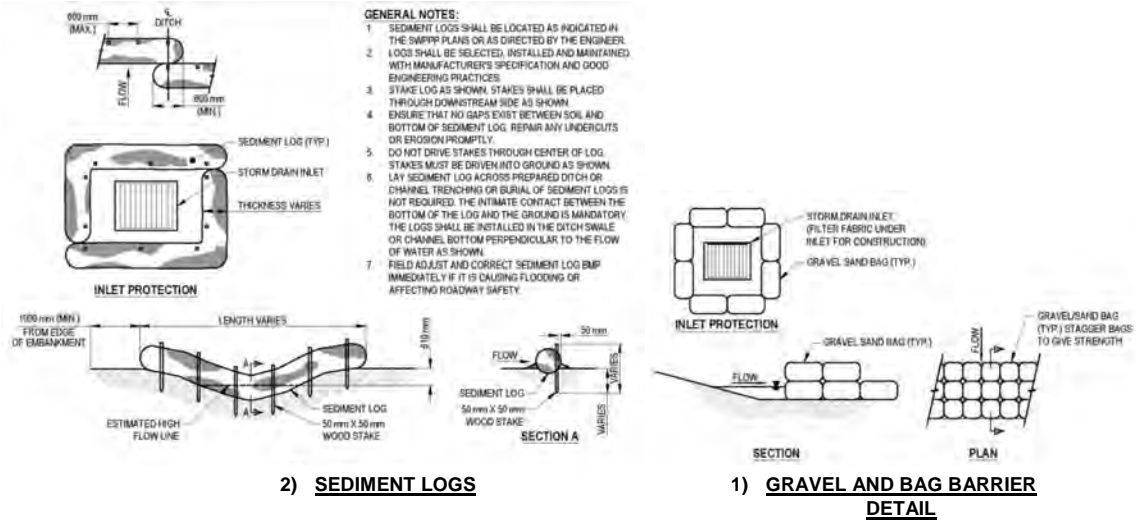

Figure 4.2-1: Culvert Sections and Details

Section 4 Design Basis and Criteria



2) SEDIMENT LOGS

1) GRAVEL AND BAG BARRIER DETAIL

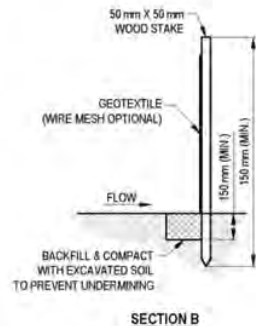
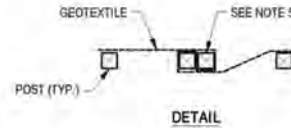
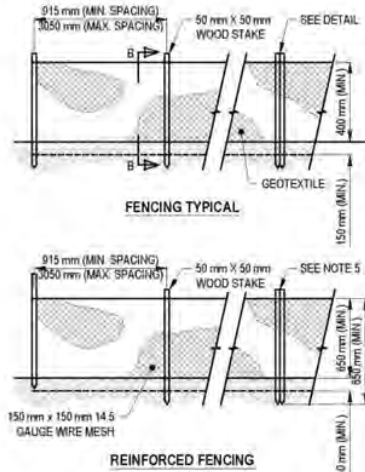

3) SILT FENCE

Figure 4.2-2: Erosion Control BMP - Sections and Details - Sheet 1 of 2

Section 4 Design Basis and Criteria

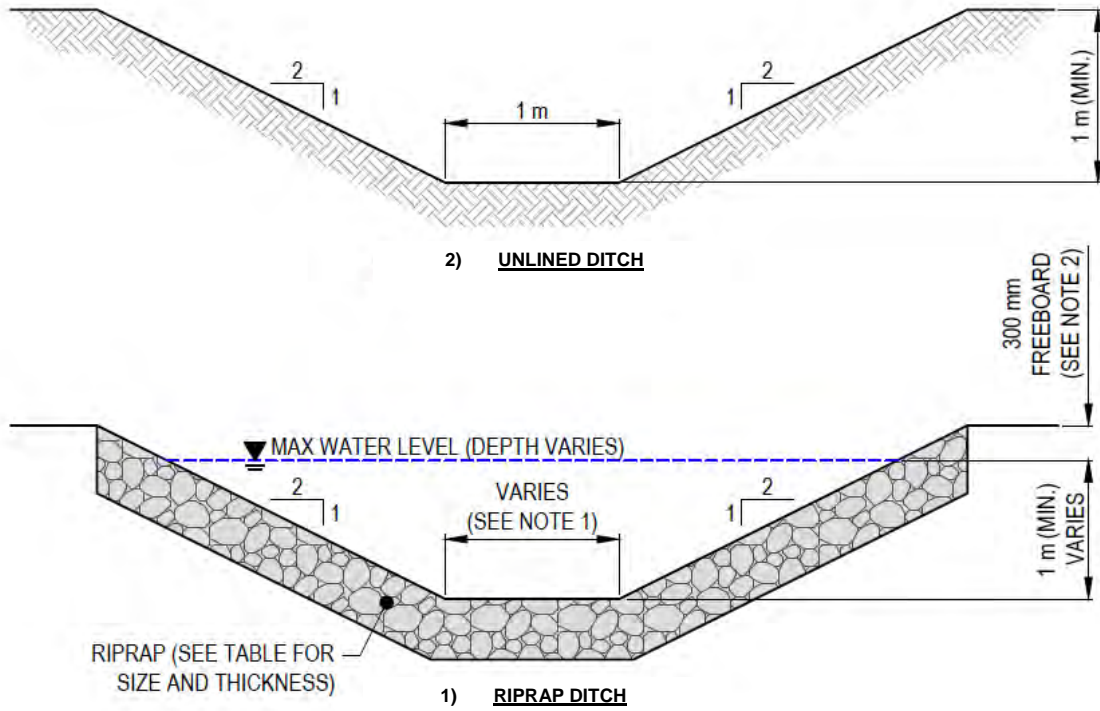

Figure 4.2-3: Erosion Control BMP - Sections and Details - Sheet 2 of 2

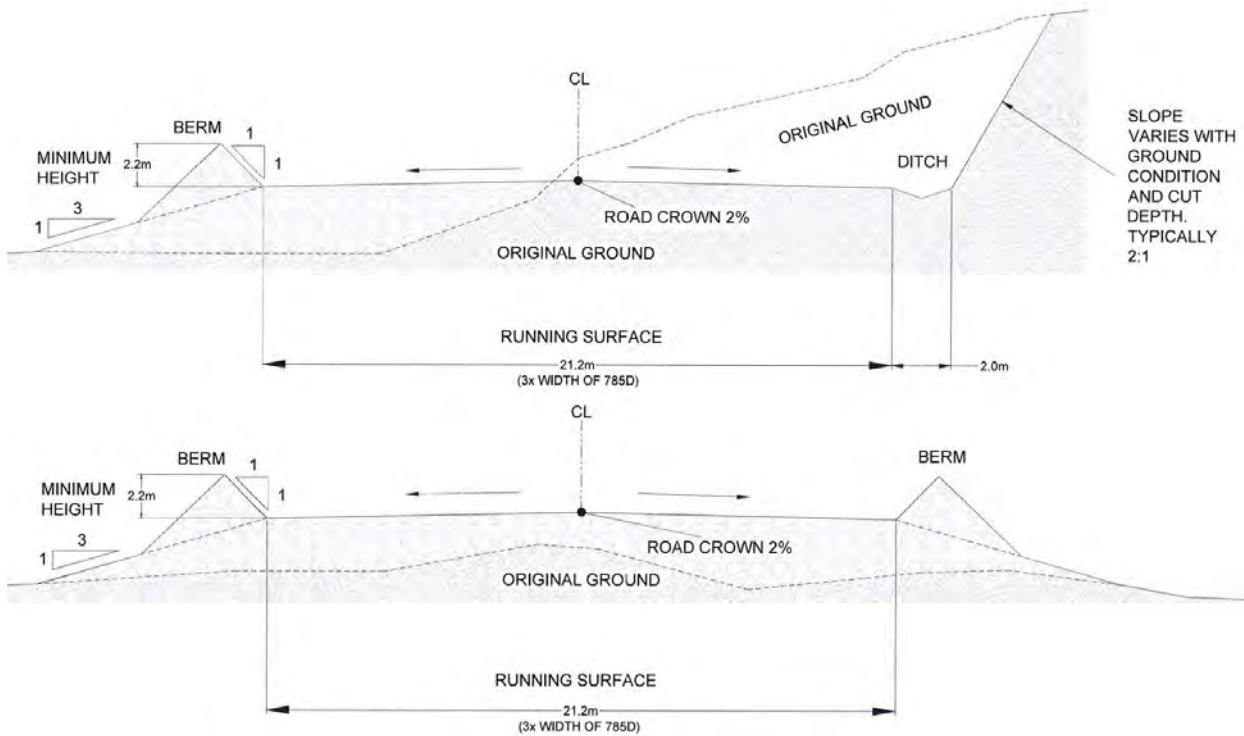

Figure 4.2-4: Haul Road Typical Cross Sections

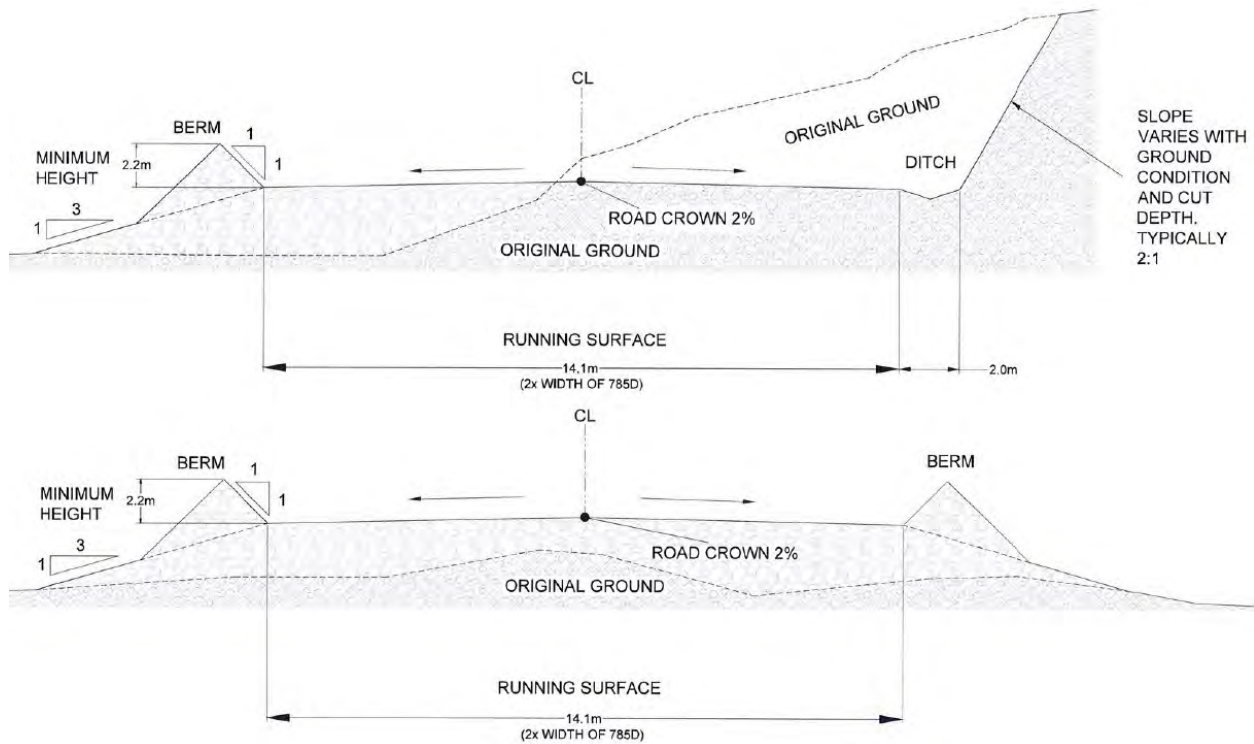

Figure 4.2-5: Mine Service Road Typical Cross Sections

4.3 DISCHARGE PROTOCOLS

When sample results are below the adaptive management threshold of a specific effluent quality criteria, monitoring frequency (of both flow rate and water quality) will continue at the specified rates provided in Tables 3.5-1 (Operations and Active Closure) and 3.7-1 (Late Closure and Post Closure) of the EMSAMP. When sample results exceed the adaptive management thresholds listed in Table 3.8-2 (Operations, Closure and Post Closure) of the EMSAMP, the sampling frequency will increase accordingly (to the next higher order) to better characterize any trends. For example, monitoring frequencies will be increased from monthly to weekly, or weekly to daily as specified by specific adaptive management actions for each threshold, until the source of the trends have been identified and mitigated.

5 WATER BALANCE, STORM WATER & GROUNDWATER

Several detailed water-related programs and models were developed and currently used for the Mine to simulate the effect of land use changes due to the Mine within the Mine study area (Haggart Creek, Dublin Gulch and Eagle Creek drainage basins). These include the:

- Water, Pond and Solution Inventory Monitoring Program (WPSIMP)
- Site Water Balance Program (SWBP)
- Sitewide Surface Water Balance Model (SWBM);
- Heap Leach Facility Water Balance Model (HLF WBM);
- Sitewide Water Quality Model (SWQM); and,
- Sitewide Numerical Groundwater Model (SGWM).

The integration of these models and programs is depicted in Figure 5.1. The model structure and inputs are dependent on a number of sources (i.e., EMSAMP, production data, and topographic and geologic data and information) that are continuously updated through the life of the Mine. These models and programs are structured to provide dynamic spatial and temporal frameworks to represent various physical conditions and simulate changes to the hydrologic regime and water management capacities over the life of the Mine. On-going modeling results provide input to the development and implementation of water management planning for all facets of the Mine. This section briefly describes each model or program that continually informs site water management evaluations and decisions.

In addition to the models described above, a stormwater model (SWM) was developed and used as part of the initial design and construction of water management infrastructure that included ponds, ditches, diversions and culverts. Since construction of infrastructure is largely complete, water management data (i.e., climate, hydrometric and pond inflow data, and infrastructure maintenance records) have been used to evaluate the relative conservatism of the existing stormwater infrastructure designs. This type of information is utilized in the WPSIMP as part of on-going water management evaluations. While the SWM is not used in on-going water management activities, some of the design elements of the model were initially integrated with the SWBM. This relationship is not depicted in Figure 5.1.

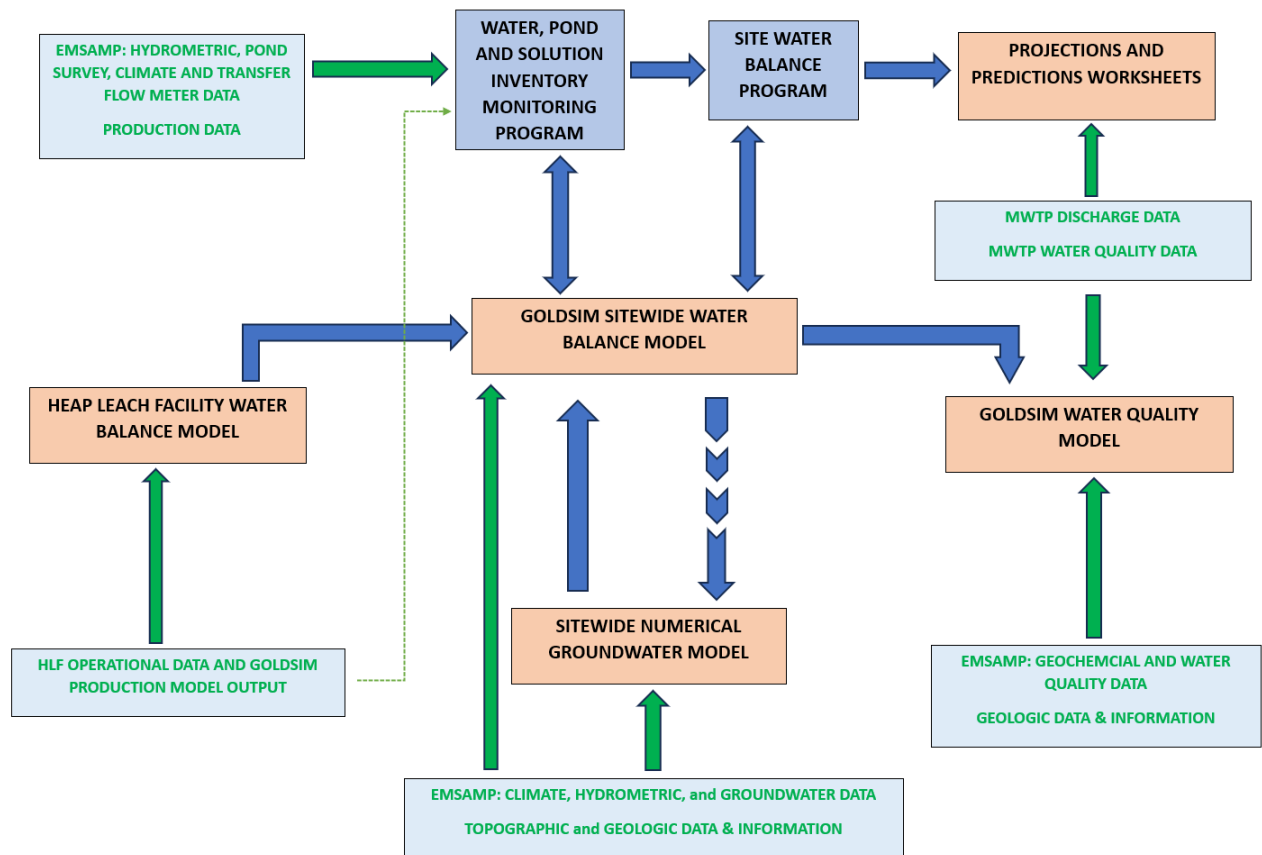

Figure 5.1: Water Management Data and Models Integration and Flow Diagram

5.1 WATER, POND AND SOLUTION INVENTORY MONITORING PROGRAM

The water, pond and solution inventory monitoring program (WPSIMP) is an Excel-based file with linked worksheets for daily water-related data on pond levels, flow transfers between ponds and facilities, flow measurements, well production, water use and water discharges to Haggart Creek.

Linked worksheets include, for example:

- LDSP: includes daily pond survey data, calculated volumes based on storage-elevation data, transfers to the EP, HLF/IHP and the MWTP;
- EP: includes daily pond survey data, calculated volumes based on storage-elevation data, transfers from the LDSP and HLF-UMV, and transfers to the ADR or HLF/IHP;
- IHP: includes daily pond and volume data provided by the Process Department;
- Deep well: includes daily pumping data for transfers to the ADR, HLF or EP;
- HLF-UMV: provides daily flow meter records of transfers to the EP;

- MWTP: daily output from MWTP operation including total discharge, min and max flows, sludge/solids wasting, and general water quality data results from treated water in the finishing tank; and
- Production look-up: tracks daily historical and mined production (tonnes of ore stacked) totals;

5.2 SITE WATER BALANCE AND ANALYSES PROGRAM

Data collected and compiled in worksheets in the Excel-based WPSIMP are used in additional worksheets that perform water balance calculations and back-calculates flows into the LDSP. This data is used for several purposes including as input to help calibrate the SWBM on an annual basis. Additional worksheets include:

- LDSP inflows and precipitation – tracks daily precipitation, LDSP inflows and associated increases;
- Precipitation and LDSP inflow rankings – ranks daily and three-day precipitation totals with daily and 3-day LDSP inflow responses;
- Desired Available Storage (DAS) and Water use: calculates and tracks available storage in the EP and IHP;
- Plots: includes charts of pond levels/volumes, water use, transfers, LDSP inflows, MWTP discharges;
- Projections Worksheet: Projects cumulative volumes to the LDSP (and All Ponds) through winter, freshet and into summer using measured and projected production data, measured and projected water transfer and use rates, and measured and modeled (exported from the GoldSim® Lorax SWBM) LDSP inflow data;
- Predictions worksheet: built on similar principles of the projections Worksheet - model inputs include variable production rates, variable water use rates, variable LDSP inflow rates based on measured or modeled scenarios, and variable ULF-UMV pumping rates; incorporates variable water management triggers and provides a one year look ahead; predicts daily flow to the MWTP while assuming pond levels do not exceed specified capacities.

5.3 SITEWIDE SURFACE WATER BALANCE MODEL

The sitewide surface water balance model (SWBM) was created and developed most recently by Lorax (2023c) in support of the Eagle Gold Mine using GoldSim®, a dynamic probabilistic simulation model used extensively for mine site water management applications. GoldSim® permits inputs to be entered as probability distributions (rather than discrete values), performs Monte Carlo simulations, tracks outputs from those simulations, and provides a graphic interface to facilitate the review and identification of interactions between components.

The SWBM is used to simulate the availability and usage of water for operating the Eagle Gold Mine, including the HLF from the initiation of mine operations through mine closure and post-closure. The WBM produces outputs of daily discharge values for Mine site stations based on the mine plan and water management activities associated with the Mine. To capture the highly dynamic nature of streamflows and water management activities at the Mine site, the SWBM is run on a daily time-step and flow outputs from the SWBM are output at a monthly time-step.

As depicted in Figure 5-1, the SWBM is an integral component of site water management, as it incorporates and is calibrated by data collected as part of the EMSAMP (e.g., hydrometric, climate, topographic, operational, internal water-transfer, mine development, etc.) and inputs from the heap leach facility water balance model (HLF

WBM) (Forte 2023), and the sitewide numerical groundwater model (GWM) (BGC 2019) to produce input for the water quality model (WQM) and other water management applications.

The SWBM watershed architecture is driven by a daily climate time-series input and is configured to include all relevant Mine infrastructure, including the HLF, open pit, WRSAs, 90-day ore stockpile, and water management infrastructure (e.g., sediment ponds, collection ditches, events pond, etc.). Within the Base Case module of the SWBM, each mine component is spatially defined by year of the Mine life, which allows the footprints (sub-catchments) and /or volumes of each component to expand as the mine development progresses. Each sub-catchment represents a single land cover type (e.g., WRSA, open pit, natural ground, etc.).

The natural catchment runoff module of the SWBM generates estimates of streamflow from climate data using a watershed modeling approach. The architecture of the watershed model is predicated on the concept that streamflow is comprised of three components: quickflow, interflow and baseflow (Maidment, 1993). The natural catchment SWBM was assembled using three reservoirs to represent these components, and the factors governing the rates at which these reservoirs fill via precipitation and snowmelt were varied by basin and/or mine component type (e.g., natural ground, WRSAs, open pit). This foundational SWBM architecture is used consistently within each natural watershed of mine sub-watershed to convert meteoric water into runoff based on sub-watersheds characteristics (e.g., elevation, surface type, water management infrastructure).

Modelled flows for each sub-catchment are routed to the next downstream node depending on water management practices or natural catchment topography, as applicable. This allows the predicted flows to be derived for any sub-watershed in the SWBM or aggregated and reported for a collection point of interest (e.g., sediment collection pond discharge, or receiving environment node, the LDSP and Events Pond for estimating the potential for maintaining an adequate level of pond storage volume for various risk scenarios). This approach also allows concentrations and loads of specific water quality parameters as part of the SWQM to be tracked for each sub-catchment, mine component and receiving water quality station to be balanced at each successive downstream node.

The HLF WBM described in Forte (2023) forms a sub-component of the site-wide water balance model as depicted in Figure 5-1, and the climate data inputs and assumptions are consistent between the two models to ensure discrepancies are not introduced by differing architecture or inputs. The SWBM is updated on an annual basis to reflect updates to the climate and hydrology databases (refer to Annual Report for the most up-to-date model report).

5.4 HEAP LEACH WATER BALANCE MODEL

The HLF WBM (currently developed and maintained most recently by Forte (2023)) is continually updated on an annual basis (see Annual Report). The model helps to evaluate HLF pad performance in terms of predicting and tracking: 1) makeup water demands, 2) water volumes in the HLF system, 3) predicting water levels in the In-heap Pond (IHP), 4) predicting HLF draindown rates, and 5) for providing output data to be integrated with the SWBM. Three (3) different types of HLF WBMs have been used to date: a weekly timestep deterministic model (using a chain of single valued input parameters to produce a series of single valued results), a weekly timestep stochastic model (probability based), and an operational model focused more on daily inputs and outputs.

The HLF WBM was initially developed and then annually updated using historic measured data for ore placement, solution measurements and management, and other relevant data as it pertains to the HLF. Model results include outputs developed for the SWBM as well as the stochastic projections surrounding the In-Heap Pond and Events

Pond. Importantly, the model results do not represent all site wide water management practices associated with the Events Pond (as those are captured in the SWBM), however they do represent water management practices surrounding the HLF. The model also incorporates site lessons learned for solution management as well as incorporating historical pond level records for the start of each annual model update.

The HLF WBM uses a large array of operational, meteorological, ore hydrodynamic properties, and metallurgical input data. During production, ore samples have been collected for testing, to characterize ore properties assumed in the model. The model incorporates details surrounding the HLF while providing operations with the ability to utilize more recorded inputs to better understand solution and pond level management. For the draindown process, several discharge scenarios (varying rates of flow to the MWTP) are examined for both the normal and climate change data sets, the effect of which yields varying durations for the period of draindown and when integrated with the SWBM and SWQM provides data to evaluate potential effects on how best to achieve water quality objectives in Haggart Creek during the draindown/closure period.

5.4.1 Deterministic Model

For the deterministic model, two updated, separate composite sets of data provided by Lorax (2022) include: 1) the 1000 m set, which uses the hydrologic 2016 year (currently assumed to be most representative) repeated as a typical year from the start of the model timeframe to closure, and 2) a climate change data set, which has the identical basis as the 1000 m set, but incorporates the effects of climate change on the weather at site. The model also utilizes the mine plan for the periods of ore stacking, gold extraction, and the initiation of draindown and closure.

Air temperature, solar radiation and potential evaporation data were also included in the site synthetic meteoric record, as they are both important factors in the climate of the site that influence fluctuations and phases of meteoric water. The division of precipitation between rain and snow and the calculation of SWE and excess water (rain and melt) are modeled using the Snow 17 submodel. The Snow 17 submodel takes average daily temperature and precipitation as the critical inputs but also corrects for seasonal solar radiation changes, latitude and altitude in the implicit calculations of melt factor and lapse rate most notably. Snow 17 also makes use of daily heat deficit accounting for determination of the internal condition of the snowpack based on the net heat transfer effects caused by the daily temperature and precipitation at the snow surface. Sublimation is calculated using heat transfer principles and is included implicitly within the Snow 17. The deterministic model tracks system storage and makeup water demand on a monthly basis.

5.4.2 Stochastic Model

For use in stochastic modeling, descriptive statistics were developed for the compiled monthly values from the 71-year synthetic meteoric record. Rather than singular climate inputs (i.e., the synthetic record), the stochastic model substitutes probability distributions for the discrete monthly rainfall, temperature, and evaporation values and samples the distributions based on the observed statistical parameters (monthly mean and standard deviation). Then the model compiles new probability distributions for the results of interest.

Stochastic modeling results are used to inform whether suitable volumes of water can be stored within the pond system and if an adequate level of emergency storage volume can be maintained. The available storage volume is defined as the total pond capacity minus the volume of water in storage within the pond system at any given point in time.

5.4.3 Operational Model

The HLF operational model is built on a GoldSim® platform with similar principals to the other two HLF WBMs in terms of tracking meteoric variability, but is computed on a 6-hour basis to track in more detail water inputs, stacking sequence, lift volumes, ore properties (e.g., moisture, density, gold grade, etc.), contained gold, solution flow rates and IHP water levels. This model supports on-going operational decisions and provides output data on a 6-hour, daily, weekly and/or monthly basis. In addition to its primary function to support ore and gold processing, the output data also feeds into the WPSIMPs and SWBP to provide data used for monthly and annual reporting as required by QZ14-041-1.

5.5 SITEWIDE WATER QUALITY MODEL

The Eagle Gold Mine sitewide water quality model (SWQM) is a mass-conserving mixing model that predicts water quality for 38 parameters at key monitoring points in the receiving waters which are compared to site-specific water quality objectives. The model was also designed on the GoldSim® platform and utilizes the SWBM, which is updated annually to reflect additional data collected (see Lorax 2023 in the Annual Report). Both the SWBM and SWQM use a daily timestep reported on a monthly basis. Model inputs include contact water source terms, effluent discharge requirements and background water quality for non-contact flows.

The model assumes that contact water comes from the following sources:

- Waste rock storage facilities in Eagle Pup and Platinum Gulch;
- Pit wall runoff and pit-wall depressurization seepage from horizontal drain holes that report to the pit;
- Heap leach facility (during post-operations and drain-down only); and
- Runoff-seepage from developed and undeveloped portions of the Mine footprint.

The effluent quality standards for the Mine listed for each component are utilized in the model. Background flows and water quality from runoff (e.g., non-contact water) and background receiving environment water chemistry are fully characterized and included in the model and, are included with Mine observed contact water quality information as model input. This database is updated for each annual revision to the model.

5.6 SITEWIDE NUMERICAL GROUNDWATER MODEL

With respect to site water management, a three dimensional (3-D) finite difference numerical groundwater flow model for the site was developed by BGC (2019) to:

- predict groundwater inflows to the Eagle pit due to natural seepage and flows from horizontal drainholes,
- evaluate the range or potential hydrogeologic impacts of the mine on surface water flows in the vicinity of mining operations,
- predict changes to the Mine area groundwater flow regime due to mining activities, and
- evaluate post-closure groundwater flow conditions.

5.6.1 Mine Groundwater Model Development

Groundwater Vistas (Version 7.23; ESI, 2017), a graphical user interface, was used to develop the MODFLOW-SURFACT (Version 3.0) groundwater flow model for the site. The groundwater flow model domain extends beyond

the Mine footprint and local topographic divides to the north and south to major streams and to the east and west to the major topographic divides. The model consists of an approximate area of 82.5 km², 65.3 km² of which is within the active model domain.

Continuous, semi-continuous and single groundwater elevation data were used with average annual and mean estimated monthly flows from hydrometric stations on Stewart Gulch, Dublin Gulch, Eagle Creek and Haggart Creek used to help calibrate the groundwater flow model to both static and transient conditions. In addition, the model was then calibrated using data from pumping tests conducted in bedrock and alluvial aquifer wells. Comparison of simulated versus observed drawdowns suggested that the calibrated hydraulic conductivity values were reasonable for the Mine scale of the modeling.

5.6.2 Model Results

5.6.2.1 Open Pit Advance and Mine Dewatering

Due to the relatively low hydraulic conductivity of the rock mass in the open pit area, pumping wells have not been used to depressurize the open pit slopes. Depressurization has been done primarily with the drilling and installation of horizontal drain holes (HDHs). While active depressurization methods were not specifically examined in the latest version of the model (BGC 2019), the model simulates the lowering of the groundwater table due to pit excavation and depressurization and quantifies the annual seepage flows. These results are then provided for the SWBM, where it is then converted to monthly input.

5.6.2.2 Groundwater Supply Extraction

While considering all the active wells in the Camp area, the SGWM results indicated that one to two groundwater supply wells installed in the bedrock of the lower Dublin Gulch valley would be sufficient to sustain the estimated groundwater supply demands (i.e., for process make-up water when the LDSP water supply is limited). Currently only one well (Deep Well or PW-BGC12-4) has been required for process make-up water.

5.6.2.3 Flow in Haggart Creek

As a result of the open pit advance, groundwater supply demands, and reduced recharge from the HLF and WRSA footprints, the model predicted lower hydraulic heads (i.e., drawdown) in the Mine footprint. During operations this was predicted to translate to a slight decrease in stream baseflow and a slight increase in stream leakage to the aquifer which resulted in stream flow reductions at W5 of generally less than 1% from May through October to 2% to 5% from December to April. Long term reductions to stream flow at W5 are estimated at approximately 0.5%. These predicted changes would be difficult to document as they are within the observed natural variability. As such, based on four years of mine development, there have been no measurable effects on streamflow.

5.7 STORM WATER MODEL

As part of the initial design of water management facilities and infrastructure, a series of hydrological models using HEC-HMS and PCSWMM software were run to estimate the inflow design flood for Ditch A, Ditch B, Ditch C, the LDSP and various culverts throughout the Mine site, and to size them based on the corresponding design events.

The more conservative adjusted rainfall frequency atlas values for extreme precipitation were used as input to the rainfall runoff hydrologic models. The relative conservatism of these assumptions has been evaluated and discussed in Section 6, as part of the process for determining Water Management Triggers for specific facilities. The general basin model developed using the HEC-HMS software is shown in Figure 5.7-1. The catchment

physical characteristics for the model are summarized in Table 5.7-1. The results of the rainfall runoff analysis are summarized in Table 5.7-2.

Table 5.7-1: Catchment Areas Used in the Model

Catchment ID	Area (km ²)	Curve Number (CN)	Lag Time (min)
Dublin Gulch	3.27	60	42
Olive Gulch	2.80	60	38
Stewart	1.66	60	27
North Dublin Gulch	0.63	60	14
Lower Dublin Gulch	0.24	60	6.8
Eagle Pup	1.47	82	41
Suttles Gulch	1.00	82	32
Ditch A	1.57	82	48
Lower Eagle Creek	0.19	82	10

Sources: Tetra Tech 2014, StrataGold 2015 and BGC 2017

Table 5.7-2: Flood Volume and Peak Runoff Values Estimated from the Rainfall Runoff Analysis

Catchment ID	Flood Volumes (1000 m ³)				Peak Flow (m ³ /s)			
	10 Year	100 Year	200 Year	1000 Year	10 Year	100 Year	200 Year	1000 Year
Dublin Gulch	3.73	21.28	28.6	48.9	3.73	1.12	1.65	3.25
Olive Gulch	3.23	18.36	28.6	42.13	3.23	1.01	1.65	2.98
Stewart	1.95	11.00	28.46	25.19	1.95	0.65	1.64	2.00
North Dublin Gulch	0.77	4.27	24.66	9.75	0.77	0.31	1.49	1.01
Lower Dublin Gulch	0.30	1.66	53.12	3.78	0.30	0.14	3.12	0.48
Eagle Pup	22.09	45.33	52.78	71.13	22.09	5.25	3.09	8.39
Suttles Gulch	15.09	30.94	14.76	48.54	15.09	3.90	0.99	6.27
Ditch A	23.82	48.85	67.54	76.64	23.82	6.16	3.95	9.91
Lower Eagle Creek	2.83	5.8	67.49	9.09	2.83	1.13	3.94	1.79
Total (Eagle Pup, Suttles Gulch and Ditch A)	61.0	125.1	135.1	196.3	61.0	15.3	8.0	24.6

Using the model, a total runoff volume of ~61,000 m³ was estimated from the Eagle Pup, Suttles Gulch and Ditch A catchments during the 10-year event. The pond was designed to store 68,522 m³ at the spillway elevation of 812.0 m asl and have a detention time of a minimum of 24 hours for settling solids. This conservatively represents the volume conveyed to and detained in the LDSP (Figure 5.7-2). Subsequent evaluations of the hydrometeorologic data assumed for the model were completed in 2017 (Lorax 2017) and then again in 2021 (Lorax 2021). The analysis indicated that the retention capacity for a 10-yr rainfall runoff event could be reduced to ~46,500 m³. This was the working assumption after pond construction was completed, resulting in an assumed surplus of ~14,500 m³ above the design conditions. These design assumptions are evaluated and discussed further in Section 6 in the development of water management triggers for the LDSP.

The LDSP design included rock-filled energy dissipators at the location of the outlets of Ditch A and B into forebay to slow down the flow and promote additional settlement for coarser material before entering the main pond. The

SWBM estimated that during the design 10-year 24-hour event, the maximum water level would be less than 811.5 m. In accordance with the design specifications and the Canadian Dam Safety Guidelines (CDA 2007, 2013), the LDSP includes a spillway capable of safely routing the 1,000-year flood during the Inflow Design Flood.

The pond and outflow levels were designed to be controlled through a riser and a low-level outlet (LLO), which consists of a perforated stand-pipe with a control gate. A submersible pump has been installed in the riser; pump outflow can be sent to a pipe junction that can direct water to the ADR for make-up water; if make-up water is not needed, water flow can also be conveyed to the MWTP for treatment prior to discharge.

The LDSP also includes an underdrain system below the liner that was installed to mitigate hydrostatic pressures on the pond liner from groundwater. The underdrains discharge downstream of the pond at LDSP-UND, and they convey non-contact groundwater to lower Eagle Creek. There is also a seepage collection ditch that collects non-contact groundwater seepage emanating from the east bank of the LDSP and conveys it to a pipe which passes under the ADR access road and joins the flow from the LDSP-UND.

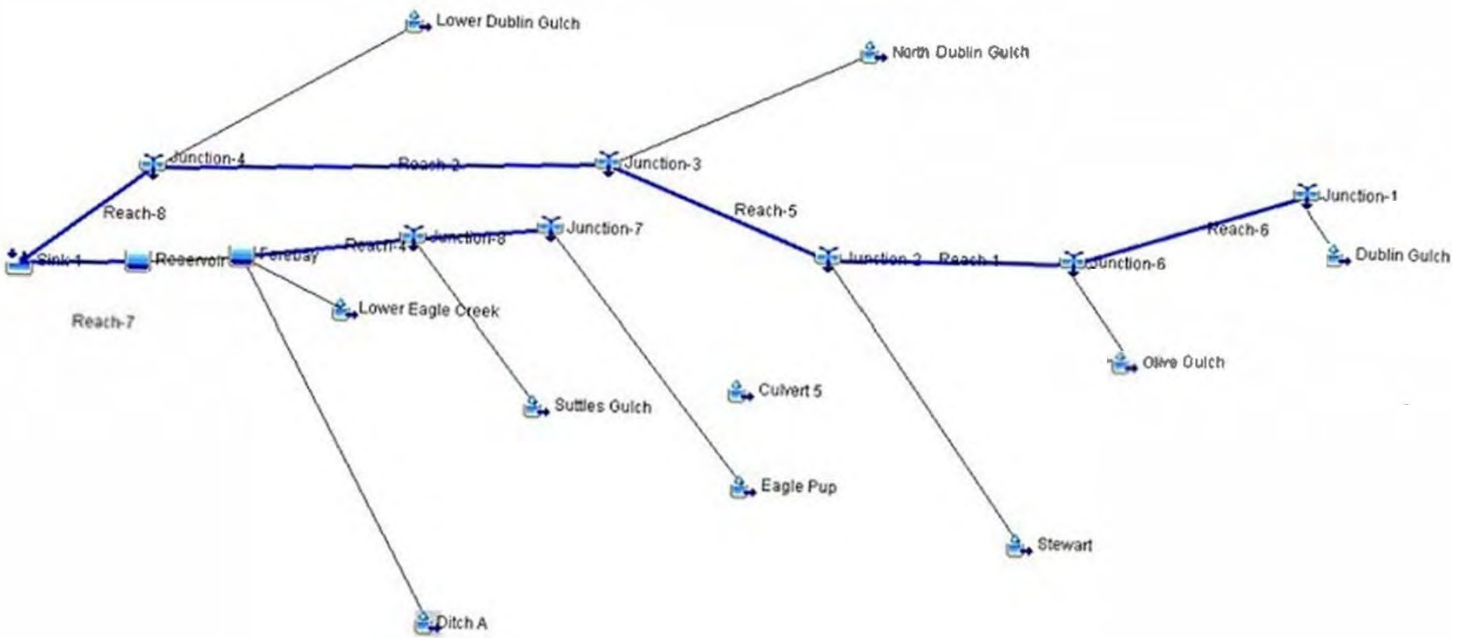

Figure 5.7-1: Eagle Gold Basin Model

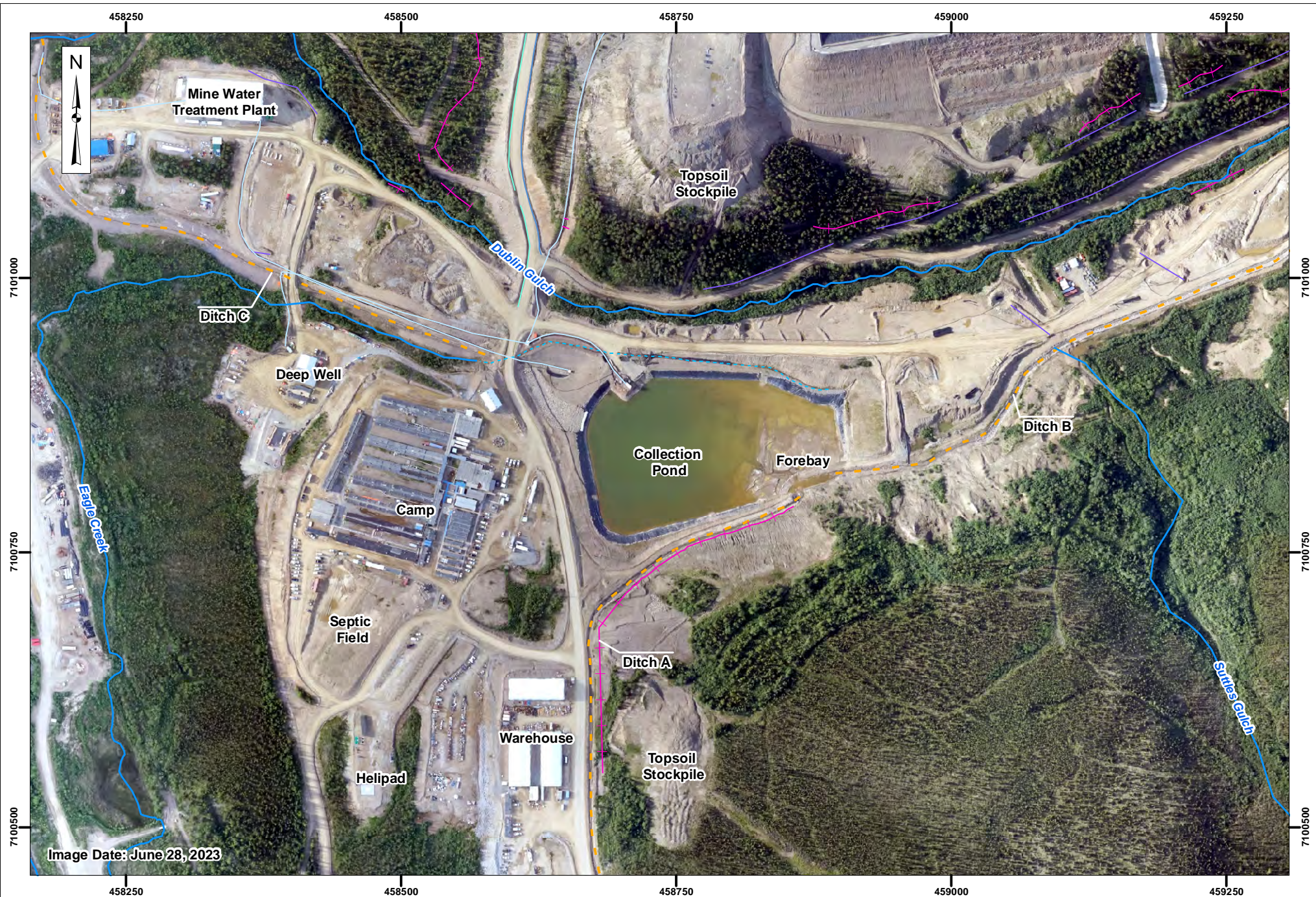

Image Date: June 28, 2023

— Watercourse	- - - - - Diversion Ditch	— Silt Fence
- - - - - Collection Ditch - Major	— Road Ditch	— Water Distribution
— Collection Ditch - Minor	— Road Berm	

VICTORIA GOLD CORP

0 25 50 100
Meters

Projection: NAD 83 UTM Zone 8	Drawn By: LM
Date: 2023-12-29	Figure: 5.7-2

**EAGLE GOLD MINE
YUKON TERRITORY**

**Lower Dublin South Pond
Current Status**

6 MINE WATER MANAGEMENT IMPLEMENTATION

The water management objective is to safely convey and/or detain the respective design storm event at each facility, while keeping clean water clean (i.e., maintaining water quality at background levels) and by meeting water quality standards in the receiving environment.

The primary means of achieving the water management objective is based on:

- selecting appropriate design inputs (as discussed above) to design the facilities and infrastructure,
- operating an integrated system of sediment-laden and contact water management transfer routing infrastructure,
- maintaining ongoing erosion source control (i.e., minimizing total suspended solid levels in runoff from disturbed areas), and,
- the diversion of non-contact water away from disturbed areas to reduce the total volume of water needing to be managed.

This section provides an overview of how the key water management facilities have been integrated with one another and also describes the approach to the management of contact and sediment-laden water.

Water is controlled in a manner that minimizes erosion and minimizes the chance of release of contact waters to receiving waters (e.g., Dublin Gulch, Haggart Creek, and Eagle Creek).

A critical consideration for all decisions for planned release of water from the Mine site is achievement of effluent quality standards at any discharge site and for meeting water quality objectives in the receiving waters (Haggart Creek). Table 6-1 provides the currently authorized discharge limits for the Mine. Table 6-2 provides the water quality objectives for Haggart Creek stations W4, W29, W99 and W23.

Table 6-1: Effluent Quality Standards

Parameter ¹	Maximum Concentration in a Grab Sample
pH	6.5 – 8
Total Suspended Solids (TSS)	15.00 mg/L
Sulphate	1850 mg/L
Chloride	250 mg/L
Nitrate-N	19.5 mg/L
Nitrite-N	0.12 mg/L
Ammonia-N	7.5 mg/L
Total Cyanide	1.0 mg/L
WAD Cyanide	0.03 mg/L
Aluminum (Dissolved)	0.4 mg/L
Antimony	0.13 mg/L
Arsenic	0.053 mg/L
Cadmium	0.00125 mg/L
Copper	0.026 mg/L

Parameter ¹	Maximum Concentration in a Grab Sample
Cobalt	0.026 mg/L
Iron	6.4 mg/L
Lead	0.05 mg/L
Mercury	0.00008 mg/L
Manganese	7.7 mg/L
Molybdenum	0.45 mg/L
Nickel	0.50 mg/L
Selenium	0.025 mg/L
Silver	0.01 mg/L
Uranium	0.09 mg/L
Zinc	0.23 mg/L

1 – All concentrations are total values except where noted

Table 6-2: Water Quality Objectives

Parameter ¹	Water Quality Objectives for W4, W29, W99, W23
Sulphate	309 mg/L
Chloride	150 mg/L
Nitrate-N	3.0 mg/L
Nitrite-N	0.02 mg/L
Ammonia-N	1.13 mg/L
WAD Cyanide	0.005 mg/L
Aluminum (Dissolved)	0.1 mg/L
Antimony	0.02 mg/L
Arsenic	0.0085 mg/L
Cadmium	0.00197 mg/L
Copper	0.005 mg/L
Cobalt	0.004 mg/L
Iron	1.0 mg/L
Lead	0.0077 mg/L
Mercury	0.00002 mg/L
Manganese	1.17 mg/L
Molybdenum	0.073 mg/L
Nickel	0.116 mg/L
Selenium	0.002 mg/L
Silver	0.0015 mg/L
Uranium	0.015 mg/L
Zinc	0.038 mg/L

1 – All concentrations are total values except where noted

As discussed in Section 2.3, no decision for a release of water from any Mine facility can be undertaken without following the roles and responsibilities RACI Matrix as depicted in Table 2.3-2. If there is any circumstance in which a release of water from key water management facilities is likely and is considered by an observer to not have been authorized in accordance with Section 2.3, then the VP - General Manager of the Eagle Gold Mine must be contacted immediately.

6.1 KEY WATER MANAGEMENT FACILITIES

Key water management facilities for the Mine include ponds, ditches and the mine-water treatment plant as shown in Figure 6.1-1.



Legend:	Sump	Watercourse - Perennial	Built	Facility
	Collection Ditch	Watercourse - Ephemeral	Not Built	Site Power
	Pipe	Watercourse - Intermittent		

VICTORIA GOLD CORP

0 100 200 400
Meters

Projection:	Drawn By:
NAD 83 UTM Zone 8	HC
Date:	Figure:
2024/04/04	6.1-1

**EAGLE GOLD MINE
YUKON TERRITORY**

**Key Water Management
Facilities Overview Plan**

6.1.1 Ponds

There are two major surface water ponds used for water management. The Lower Dublin South Pond (LDSP and aka Control Pond) is the principal mine-site pond used to collect and retain all mine site contact water south of Dublin Gulch. The other major surface pond, the Events Pond (EP) serves two main purposes: 1) to provide sufficient emergency storage for an upset event occurring in the HLF (e.g., in-heap pond overflow), and 2) to provide storage for process make-up water where the water originates from the LDSP, is transferred from the HLF-UMV or occurs as direct rainfall/snowmelt. The third important water management facility is the In-Heap Pond (IHP), which is the saturated water column behind the HLF embankment. While the IHP is a component of site water management, its principal function is for the collection of leached gold-bearing solution to be transferred to the ADR for gold production.

6.1.1.1 Lower Dublin South Sediment Control Pond

The LDSP is managed as a lined retention pond that collects water from disturbed areas in the southern section of the Mine including runoff, seepage and mine water routed from the Eagle Pup WRSA via Ditch B, the Platinum Gulch WRSA via Ditch A, the crusher areas in Suttles Gulch via Ditch B, and the open pit via Ditch A or B.

The LDSP was designed (Tetra Tech 2014) and built to store the estimated 10-year, 24-hr storm event for all surface runoff from the catchments that report to Ditch A and Ditch B while at the same time providing a retention time of at least 24 hours for any sediment particles sized 0.005 mm (and larger) to settle out. The spillway of the pond was designed to pass the 1,000-year, 24-hour storm while still maintaining at least 0.5 m of freeboard as per CDA guidelines. While the main pond liner was completed in late 2017, the forebay liner was completed later in early 2021.

Water collected and retained within the LDSP is managed to be:

1. dispatched directly to the HLF pad as makeup water (see Section 7),
2. transferred to the Events Pond for additional settling,
3. routed to the MWTP,
4. utilized for other site needs (i.e., dust suppression or drilling) or,
5. discharged to Haggart Creek via either Ditch C or a pipeline within Ditch C provided that the water meets WUL and MDMER discharge requirements.

Ditch C flows into Haggart Creek about 200 m downstream from the mouth of Dublin Gulch (Figure 6.1-1) and upstream of the water quality monitoring station W4.

The management of the LDSP is based on season and when pond levels reach certain triggers. Pond levels are surveyed daily. Each measured level corresponds to a pond volume based on the design storage-elevation curve. Over time, as sediment has accumulated in the pond, the pond storage-elevation curve has changed such that the total pond volume when first constructed (68,103 m³) has been reduced to 60,103 m³ as of September 2022 (Table 6.1-1), when the last bathymetric survey was completed (Golder 2022). Revision of the pond storage-elevation curve will be undertaken as deemed necessary based on observation of sediment inflows and forebay clean out activities (which are currently scheduled for completion in Q1 2024).

Table 6.1-1: Change in Pond Capacities Due to Sediment Infill Since Construction

	Year Built	Design Capacity (m ³)	Sept 2022 Capacity (m ³)	Capacity Remaining
Control Pond	2017	68,522	60,103	88%
Events Pond	2018	300,577	292,056	97%

6.1.1.2 Events Pond

The Events Pond (EP) was designed (BGC 2018) to provide emergency storage for potential upset events (e.g., temporary power loss resulting in the cessation of pumps and an overflow from the IHP, a very high magnitude rainfall/snowmelt event occurring within the HLF). The pond is also managed as a retention pond that collects water from three sources: 1) transfers from the HLF UMV, 2) transfers from the LDSP and 3) from direct precipitation, while at the same time maintaining sufficient available storage (the Desired Available Storage (DAS)) to contain a specified upset event. The pond provides water to the ADR for freshwater make-up and fire suppression, or directly to the HLF pad/In-Heap Pond.

While the EP's main function is not as a settling pond (like the LDSP), over time sediment has accumulated from water transferred from the LDSP and airborne particles. As a result, the pond storage-elevation curve has changed such that the total pond volume when first constructed (300,577 m³) has been reduced to 292,056 m³ as of September 2022 (Table 6.1-1), when the last bathymetric survey was completed (Golder 2022). An important element for the management of the Events Pond is the determination of the DAS. This is discussed below in Section 6.1.1.5.

6.1.1.3 In-Heap Pond

The IHP is the saturated ore column behind the HLF embankment, and its principal function is for the collection of leached gold-bearing solution to be transferred to the ADR for gold production. However, it also functions as a water management facility and accepts water transfers directly from the EP or the LDSP (as well as the Deep Well). The IHP maximum volume (57,763 m³) is referred to as the maximum pumpable volume (total capacity or pores minus field retention), and is calculated assuming full ore saturation, ore porosity behind the embankment up to the IHP spillway. The Process department operates the pond with alert thresholds which are described fully in the HLF OMS. The IHP also figures importantly as part of the DAS calculation (see Section 6.1.1.5).

6.1.1.4 Supplemental Water Storage Pond

As a further contingency measure for water storage capabilities, an additional water management pond (the emergency pond) was designed for construction within the Dublin Gulch valley. In response to stored volumes in prior years, a portion of the pond area was excavated; However, due to diligent water management actions at that time, was never utilized.

6.1.1.5 Desired Available Storage

As defined by QZ14-041-1, the Desired Available Storage (DAS) is:

- for Phase 1: 198,340 cubic metres for HLF Phase 1; or
- for Phases 2 and 3, the minimum volume of available storage required to capture the full volume of a 100-year, 24-hour rainfall volume on the plan area of the HLF, exclusive of the ADR watershed area, plus 72 hours of draindown at a rate of 2,070 cubic metres per hour, plus the volume of freeboard at 0.5 m below the EP spillway invert.

From an operational standpoint, available storage to meet DAS criteria is determined using a combination of available storage in the EP and the IHP at any given time, where the calculation for DAS would incorporate the actual barren flow rate.

Table 6.1-2: Desired Available Storage Volume

Phase	100-Year 24-Hr Storm Volume (m ³) ¹	72 Hr Draindown Volume (m ³) ²	Freeboard (m ³) ³	Desired Available Storage Volume (m ³)
1	29,700	149,040	19,600	198,340
2	41,220	149,040	19,600	209,860
3	57,610	149,040	19,600	226,250

Notes:

1: Based on a 100-Yr 24-Hr storm rainfall depth of 53 mm (Lorax 2021)

2: Based on a solution pumping rate of 2,070,000 liters/hr

3: Based on a pond depth freeboard of 0.5 m in the Events Pond

6.1.2 Ditches

There are three main ditches related to sediment-laden and contact water constructed for the Mine, shown on Figure 6.1-1 and described below:

Ditch A is located downslope from the open pit, the Platinum Gulch WRSA, the 90 day stockpile and the open pit access road. Ditch A is entirely lined with impermeable liner, overtopped with riprap, and runs north from the drainage basin of the Platinum Gulch WRSA across the site and into the Lower Dublin South Pond.

The entire stretch of **Ditch B** is lined with impermeable liner, overtopped with riprap, and follows the natural Eagle Creek watercourse; Eagle Creek receives runoff from the Eagle Pup WRSA, and Suttles Gulch which contains the crusher installations and part of the Eagle Pit. Ditch B flows west across site from the northern end of the Eagle Pup WRSA to the LDSP.

Ditch C is downslope of the LDSP, lined with riprap, and conveys the outflow from the pond to Haggart Creek. Ditch C flows west to a discharge location upstream of W4.

The hydrologic model described in Section 5.4 was used to predict the design flows for each ditch. The design criteria and design flows are presented in Table 6.1-3.

Table 6.1-3: Water Management Ditch Design Specifications

Ditch	Design Criteria	Rainfall Depth (mm)	Rainfall Distribution	Peak Intensity (mm/h)	Catchment Area (ha)	Design Flow (m ³ /s)
Ditch A - Upstream of Culvert 8	1 in 100-yr, 24-hour	71.6	Type 2	79.48	133.8	5.3
Ditch A - Downstream of Culvert 8	1 in 100-yr, 24-hour	71.6	Type 2	79.48	157.4	6.2
Ditch B	1 in 100-yr, 24-hour	71.6	Type 2	79.48	246.3	8.9
Ditch C	IDF from Emergency Spillway	-	-	-	422.2	24

A PCSWMM hydraulic model was implemented as part of the design process to predict velocity and water depth along the ditches.

The design of the ditches was based on the gradient and volume of flow anticipated. Table 6.1-4 presents the ditch characteristics and specifications for riprap protections. The stationing increases in the downstream direction.

Table 6.1-4: Collection Ditch Specifications

DITCH A Specifications												
ID	From Station (m)	To Station (m)	Length (m)	Slope (%)	Velocity (m/s)	Max. Depth (m)	Bottom Width (m)	Side Slopes (XH:1V)	Class of Riprap (kg)	D50 (mm)		
1	0	355	355	2 - 5	1.3 - 2.0	1.4	1	2	10	195		
2	355	519	164	1 - 2	1.0 - 2.8	1.6	1	2	No riprap required			
3	519	575	56	Culvert 8								
4	575	845	270	2 - 5	1.6 - 2.2	1.2	1	2	10	195		
5	845	1020	175	1 - 2	2.4 - 2.9	1	1	2	No riprap required			
6	1020	1195	175	2 - 5	2.0 - 3.0	1	1	2	25	260		
7	1195	1155	135	6 - 15	3.7 - 4.6	0.8	1	2	25	260		
8	1155	1240	45	6 - 15	6.9	0.6	1	2	500	715		
9	1240	1200	45	> 15	10.4	0.4	1	2	Culvert Lined			
DITCH B Specifications												
ID	From Station (m)	To Station (m)	Length (m)	Slope (%)	Velocity (m/s)	Max. Depth (m)	Bottom Width (m)	Side Slopes (XH:1V)	Class of Riprap (kg)	D50 (mm)		
1	0	45	45	Culvert 5								
2	45	50	5	Gabion steps – 3 meter drop								
3	50	560	510	6 - 15	3.4 - 6.2	1.1	1	2	250	565		
4	560	1026	466	2 - 5	2.0 - 2.9	1.3	1	2	25	260		
5	1026	1120	94	6 - 15	5.0 - 5.4	1	1	2	250	565		
DITCH C Specifications												
ID	From Station (m)	To Station (m)	Length (m)	Slope (%)	Velocity (m/s)	Max. Depth (m)	Bottom Width (m)	Side Slopes (XH:1V)	Class of Riprap (kg)	D50 (mm)		
1	0	20	20	6 - 15	3.7	1.9	2	2	50	330		
2	20	57	37	2 - 5	1.3 - 2.0	2.9	2	2	10	195		
3	57	90	33	Culvert 1								
4	90	287	197	2 - 5	2.3 - 3.9	1.8	2	2	25	260		
5	287	407	120	6 - 15	5.9 - 7.4	1.5	2	2	500	715		
6	407	624	217	2 - 5	2.9 - 3.1	1.6	2	2	25	260		
7	624	657	33	Culvert 9								
8	657	687	30	2 - 5	2.9 - 3.1	1.6	2	2	25	260		

6.1.3 Mine Water Treatment Plant

The purpose of the MWTP is to treat contact waters stored in the LDSP or EP to reduce the concentrations of contaminants of concern before discharging to Haggart Creek. The treatment process is designed to treat primarily heavy metals through pH adjustment, oxidation and iron precipitation/co-precipitation. Solids laden with

contaminants are removed by clarification and filtration before the treated water is discharged to the environment. Solids are prepared with a filter press to remove excess water and then disposed of in the solids disposal facility. The MWTP is designed to receive a steady daily average of approximately 8,500 m³/day, with a maximum daily average of approximately 14,500 m³/day. The MWTP began operations in January 2023.

6.1.3.1 Design

The MWTP is designed to treat a varying combination of site contact water originating from the open pit and WRSAs, as well serving as a back-up to treat excess water from the HLF primarily during the initial drain-down (Phase 6). The MWTP lies north and west of the Camp near the beginning of the lower access road and approximately 100 meters north of Ditch C. This site provides good access for chemical delivery trucks and minimizes major pipe runs. The MWTP raw water feed comes from either the LDSP or EP. The feed lines join at a junction near the LDSP and just east of the ADR access road, where it then passes under the road and down to the MWTP through an insulated and heat traced HDPE pipeline.

The MWTP has been designed to treat for primarily suspended solids and arsenic and be flexible and expandable to accommodate a wide range in flows as predicted by the Site Water Balance and Water Quality Model (SWBWQM) (see Section 5.3), and to meet effluent quality criteria as specified in QZ14-041-1. Water quality modeling also indicated that during later stages of Phase 3, nitrate/nitrite treatment would be needed, and during closure Phase 6 (i.e., primarily drain-down of the HLF) 11 total parameters may require treatment. These parameters include pH, TSS, nitrate, nitrite, WAD CN, As, Sb, Pb, Hg, Se, and U. Detailed bench testing (Linkan 2021) has provided the basis of the MWTP design.

Within the building envelope of the MWTP and as part of design planning, there is space provided in the plant for future modifications that will allow the plant to treat nitrites/nitrates and other heavy metals as necessary during HLF draindown. Thus, the MWTP may be modified in the future to address predicted flows and water chemistry associated with the HLF drain down, coupled with the current upstream cyanide destruction plant located within the ADR.

The MWTP currently consists of three primary treatment trains, which can be operated independently or in parallel. If the water does not meet discharge requirements (e.g., pH out of specifications), the water can be returned to the LDSP either before the microfiltration (MF) system or prior to environmental discharge. The MWTP equipment is designed to operate at a minimum building air temperature of 7°C. During the extended periods of shutdown over the winter, the plant will require winterization.

Raw water from the LDSP is transferred to the MWTP through an HDPE pipeline to the oxidation tank and then the reaction tank where chemicals are added to create iron floc for As adsorption and pH adjustment. The floc is then pumped to inline plate clarifiers for settling. The decanted water feeds the MF units where any remaining unsettled solids are removed. Settled solids from the clarifiers are then pumped to the thickener, where they are pressed in a plate and frame filter press. The solids are stored in roll-away bins which are transferred periodically to the solids repository. The press filtrate and thickener decant is returned to the reaction tank. Captured suspended solids from the MF is also returned to the reaction tank to be settled in the clarifiers. MF filtrate water is then pH-adjusted and dechlorinated as needed to meet discharge standards and sent to the finishing tank, where it is sampled and tested to ensure EQS are met. Treated water in the finishing tank is then discharged to Haggart Creek. Technical specifications for the MWTP are described in more detail in Linkan (2023).

6.1.3.2 Construction and Commissioning

Preparations to construct the Mine Water Treatment Plant (MWTP) began in December 2021. Clearing and leveling of the MWTP pad began in December 2021. Construction began in earnest in January 2022 as infrastructure began to arrive on site. The concrete floor and sumps were completed in Q1 of 2022. Following the completion of foundation works, tanks and infrastructure began to be installed throughout Q2, 2022. By the end of Q3, 2023 the building envelope had been erected to protect the infrastructure from winter weather. In December of 2022 all infrastructure had been erected and installed so that electrical and computer logic systems could be tested. Final construction and commissioning of the MWTP occurred in early 2023.

6.1.3.3 Operations

The proper use and control of the MWTP is described in Linkan (2023) Operation & Maintenance Manual, Victoria Gold WTP, February 2023. The MWTP began operating and discharging on January 17, 2023. It ran continuously until February 23, 2023. Operations began again on April 21, 2023 in response to freshet inflows to the ponds, and it ran to June 25, 2023. The plant feed averaged approximately 5,050 m³/day during the Jan-Feb discharge and 4,540 m³/day during the April-June discharge. All the operations were well within design specifications.

The plant can be operated over a range of feed rates. This is an important element of adaptive management planning, to be able to adjust flow rates to help meet water quality objectives in Haggart Creek. This is discussed further in Section 6.3 (Water Management Targets and Actions).

6.1.3.4 Starting the MWTP After an Extended Shutdown Period

After an extended shutdown period (e.g., more than two months), a full plant inspection needs to be completed within two weeks (to allow sufficient time to rectify any issues) of restarting operations to check that all hand valves are in their proper positions, all equipment is powered on and in AUTO (the plant control logic process controller) at their local hand/off/auto switch, all analytical elements are installed and calibrated, sufficient chemical is available, and the air compressors and receivers are functioning properly. Section 4.1 of the OMS (Linkan 2023) describes the items to verify during a plant walkthrough.

6.1.3.5 MWTP Solids Residue

The MWTP currently produces solids which consist of the ferric chloride coagulation treatment process solids. Low pH solids will be generated during both the operational Phases 2-5 and closure Phase 6. They are pressed with a plate and frame filter press and disposed of in the lined repository adjacent to the land treatment facility.

During the early closure (Phase 6), additional solids from the treatment process targeting the removal of mercury and other heavy metals will be generated. These solids will be pressed with a plate and frame filter press and disposed of at a location to be determined.

6.1.3.6 Cyanide Destruction

The ADR plant is equipped with a reaction tank and a Caro's Acid reactor which provides an operational cyanide destruct circuit in the extreme case that there is excess cyanide solution that needs to be treated.

Caro's acid, also known as peroxymonosulphuric acid (H₂SO₅), is a powerful oxidant that is commonly and effectively employed to treat tailings and wastewaters containing cyanide resulting from gold processing operations. It is produced by mixing concentrated hydrogen peroxide (H₂O₂) and sulfuric acid (H₂SO₄) according to the reaction:

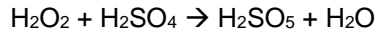

The formation of Caro's acid is instantaneous upon mixing. However, because the heat produced from the dilution of the sulfuric acid promotes decomposition to oxygen and sulfuric acid, Caro's acid must be used immediately upon generation to be effective.

The reaction of Caro's acid with free cyanide (CN⁻) proceeds according to the following reaction:

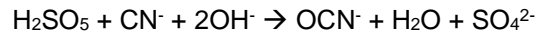

Reactions with weak acid dissociable (WAD) cyanide species are similar, and all proceed very rapidly achieving complete oxidation to cyanate (OCN⁻) within minutes. This is one of the principal advantages of Caro's acid. The short reaction time allows for the destruction process to be carried out in relatively small tanks or even transfer piping in some cases. The other main advantage is the reaction by products are the most benign of any commonly used cyanide destruction process with the final products being bicarbonate and nitrate. The process does not require a copper catalyst, that must then be removed prior to discharge, as in the INCO sulfur dioxide and hydrogen peroxide approaches, and there is no toxic cyanogen chloride produced as in the alkaline chlorination process. Detailed descriptions of the processes described above and the chemistries involved can be found in the references cited below.

The free sulfate (SO₄²⁻) left in solution following the cyanide destruction step will subsequently react with alkaline earth species, primarily calcium (Ca²⁺), to form precipitate solids. However, the concentration of these metals in HLF solutions is relatively low. The theoretical total suspended solids (TSS) in the effluent, assuming 100% precipitation, is on the order of 0.7 g per liter. Even assuming no dilution from mine water, this is in line with the design criteria for the solids removal stages of the MWTP.

6.2 KEY WATER MANAGEMENT HYDROMETRIC STATIONS AND TRANSFER MONITORING WITHIN THE MINE FOOTPRINT

The monitoring and measurement of the flow and transfer of water within the Mine footprint is one of the more important water management practices at the Eagle site. Figure 6.2-1 depicts, and Table 6.2-1 summarizes both WUL and internal water transfer sites that are currently monitored throughout the site.

Table 6.2-1: Minesite Hydrometric Stations

WUL Station Category	Station	Station Name	2024 Status	Type of Flow Measurement	Notes
Compliance	LDSP	Lower Dublin South Pond (LDSP) Outflow	Active	Continuous during discharge	Active only during discharge events
	LDSP-UND	LDSP underdrain outlet	Active	Manual Spot Flow	--
	CS-07	SG-G4 – below Ice Rich Overburden Storage Area	Not Active	N/A	--
	MWTP Discharge	Mine Water Treatment Plant Discharge	Active During Discharge	N/A	--
	HLFUMV	Heap Leach Facility Underdrain Monitoring Vault	Active	Continuous during discharge	All flows are transferred to the EP
	ADR Pad Ditch	ADR Pad Ditch Outlet	Not Active	N/A	--
	E-A	EP to ADR	Active	Flow Meter	
	E-H	EP to HLF	Active	Flow Meter	

Section 6 Mine Water Management Implementation

WUL Station Category	Station	Station Name	2024 Status	Type of Flow Measurement	Notes
Internal Water Transfers	E-L	EP to LDSP	Active	Flow Meter	
	L-A	LDSP to ADR	Active	Flow Meter	
	L-H	LDSP to HLF	Active	Flow Meter and SIMPs calculations	
	L-E	LDSP to EP	Active	Flow Meter	
	D-A	Deep Well to ADR	Active	Flow Meter	
	EPS	Eagle Pup WRSA Seepage	Active	Manual Spot Flow	--
	PDI & PG_PTS	Platinum Gulch Ditch into LDSP	Active	Manual Spot Flow	PG_PTS not active, will be activated once PTS is commissioned.
	PGS	PGS WRSA Seepage	Active	Manual Spot Flow	Transfer between engineered structures
	PS	Open Pit Sump	Not Active	Manual Spot	Combined from HDHs
	FT	Mine Water Treatment Plant Finishing Tank	Not Active	Continuous during discharge	--
	LDSPI	Low Dublin South Pond Inflow	Active	Manual Calculated	LDSPI calculated using SIMPs, pond surveys, transfer flow meters and on inflows from Ditch A and B
	OPP ²	Open Pit Pond	Not Active	--	--
	OPPO ²	Open Pit Pond Overflow	Not Active	--	--

Notes:

1 – During Active Closure Only

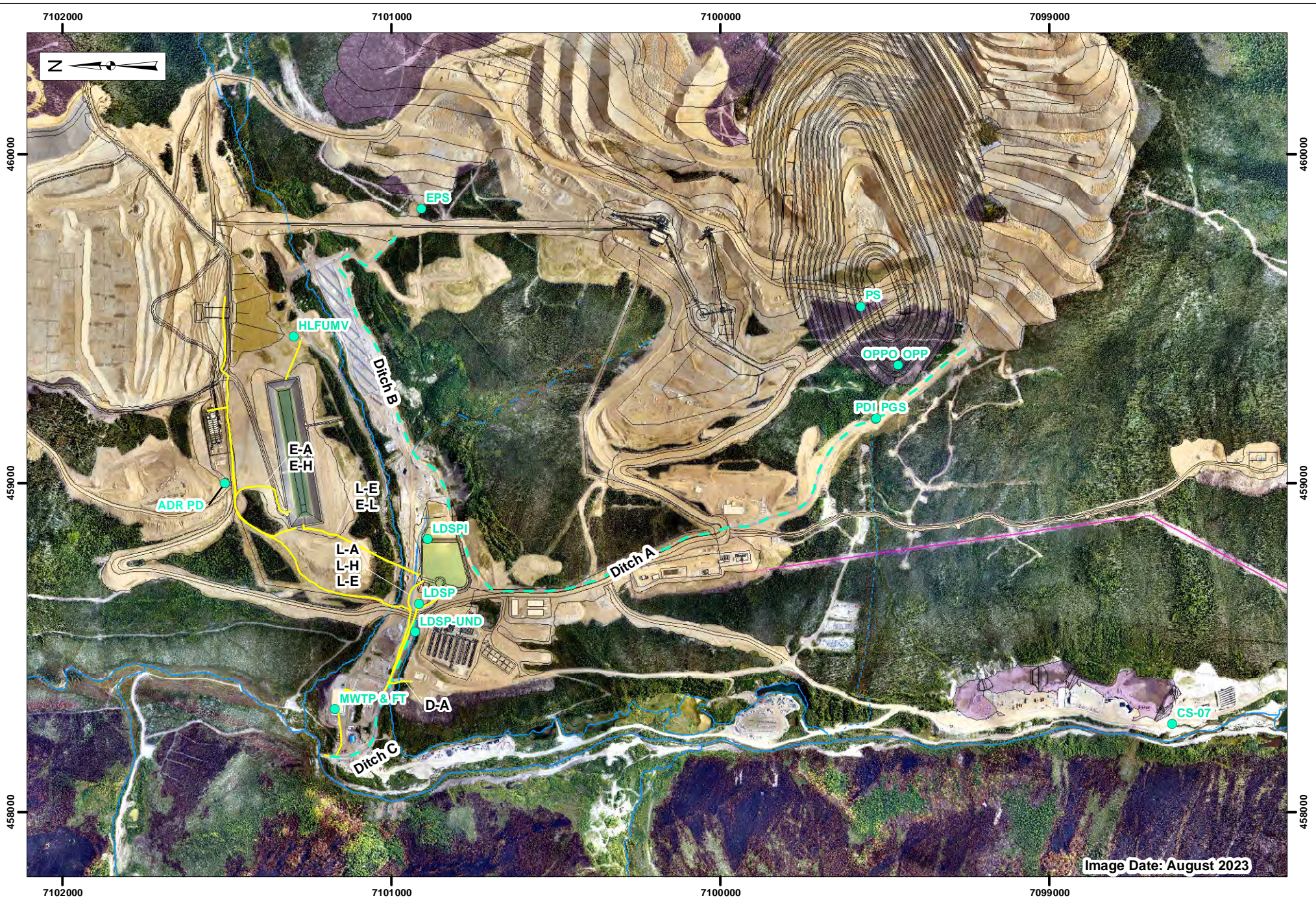

Legend:		
● Water Quality and Flow Monitoring Station	— Watercourse - Perennial	— Facility
- - - Collection Ditch - Main	- - - Watercourse - Ephemeral	— Site Power
— Pipe - Transfers	- · - · - Watercourse - Intermittent	

VICTORIA GOLD CORP

0 100 200 400
Meters

Projection: NAD 83 UTM Zone 8	Drawn By: HC
Date: 2024/02/27	Figure: 6.2-1

**EAGLE GOLD MINE
YUKON TERRITORY**

**Key Water Management
Facilities & Transfer Monitoring**

6.3 WATER MANAGEMENT TARGETS AND ACTIONS

Developing and determining water management targets require considerations of the following:

- Design criteria
- WUL conditions
- 2020-2023 LDSP inflow rates, seasonal variability, LDSP pond levels/volumes
- 2020-2023 EP levels/volumes, seasonal variability
- 2020-2023 IHP levels/volumes, seasonal variability
- 2020-2023 capacities for pumping/transferring water
- MWTP design and operating ranges
- Revisions to design capacities

Design criteria and WUL Conditions are described above in Section 6.1-1 for each facility.

6.3.1 LDSP Inflows and Pond Levels 2020-2023

6.3.1.1 Summer LDSP Targets

The largest measured 24-hr LDSP non-freshet (primarily rain with some snowmelt) inflow since April 2020 was 17,270 m³/day on May 27, 2023. Based on the time of year, this flow was likely influenced somewhat by snowmelt or at least very wet antecedent moisture conditions. The largest measured 24-hr LDSP inflow increase from the previous day that was not obviously affected by snowmelt was only 8,130 m³/day (Table 6.3-1). Similarly, the largest measured 72-hour LDSP non-freshet inflow was 29,820 m³/day (Table 6.3-2).

Table 6.3-1: Top Ten 24-hour LDSP Non-Freshet Inflows

Rank	Date (yyyy-mm-dd)	24- hour Camp Precipitation (mm)	24-hour LDSP Inflow (m ³)	Primary Factor
1	2023-05-27	12.7	17,269	Rain with Snowmelt
2	2023-05-23	13.8	13,515	Rain with Snowmelt
3	2022-10-10	10.1	9,411	Freeze-up
4	2023-05-28	1.3	8,649	Rain with Snowmelt
5	2023-05-24	1.9	8,517	Rain with Snowmelt
6	2022-07-18	5.1	8,131	Summer Wet Period
7	2021-08-10	27.1	7,957	Summer Rain
8	2022-08-10	0.8	7,388	Summer Wet Period
9	2021-07-25	39.3	7,259	Summer Rain
10	2021-05-30	3.7	6,986	Rain with Snowmelt

Table 6.3-2: Top Ten 3-day LDSP Non-Freshet Inflows

Rank	Date (yyyy-mm-dd)	72- hour Camp Precipitation (mm)	72-hour LDSP Inflow (m ³)	Primary Factor
1	2023-05-29	14.0	29,823	Rain with Snowmelt
2	2023-05-28	14.0	29,264	Rain with Snowmelt
3	2023-05-24	20.8	27,366	Rain with Snowmelt
4	2023-05-23	18.8	25,424	Rain with Snowmelt
5	2023-05-25	15.7	24,755	Rain with Snowmelt
6	2023-05-27	12.7	23,339	Rain with Snowmelt
7	2022-10-12	10.2	15,408	Freeze-up
8	2022-10-11	12.3	15,138	Freeze-up
9	2022-10-10	12.3	14,845	Freeze-up
10	2021-08-23	21.9	13,917	Summer Rain
11	2021-08-22	21.9	13,630	Summer Rain
12	2021-08-10	29.0	13,585	Summer Rain
13	2021-08-11	27.6	13,363	Summer Rain
14	2022-07-20	33.9	12,782	Summer Rain
15	2022-07-19	42.9	11,811	Summer Rain

Based on a comparison of the LDSP inflow data collected since 2019 to the Tetra Tech 2014 design values (based on Knight Piesold hydrometeorologic data), it is evident that the 3-day inflow totals appear to be approximately 49% of the design inflow (61,000 m³) for the 1:10-year 24-hour flood. Further, based on data collected up to July 11, 2023, the Knight Piesold/TetraTech 24-hour 2, 5 and 10-yr design flows are 6.0 to 11.8 times greater than the maximum measured 24-hour LDSP inflows. Thus, assuming the LDSP hydrometric record is valid, it is apparent that the design capacity for the LDSP was very conservatively overestimated (and see Section 2.4 in Lorax 2022).

Based on these data, the 2-yr, 5-yr and 10-yr LDSP design inflows for determining water management triggers have been adjusted downward to reflect the measured inflow responses to measured rainfall at the Camp station from 38,510 m³/day, 51,930 m³/day and 61,000 m³/day to 17,270 m³/day (which is the largest observed in a three-year period), 22,800 m³/day and 26,250 m³/day, respectively. These values become the T1, T2 and T3 triggers for the LDSP.

6.3.1.2 Pre-Freshet LDSP Targets

Pre-freshet readiness for the LDSP is based on an understanding of potential wintertime (defined here as Nov 1 to Mar 31) LDSP inflows, knowing that there will be a water demand for heap operations that can be met by the LDSP inflows, and that any excess volumes accumulated over winter can be discharged through the MWTP. Since 2020, the largest monthly inflows have occurred in April and May, largely due to snowmelt during the freshet season (Figure 6.3-1).

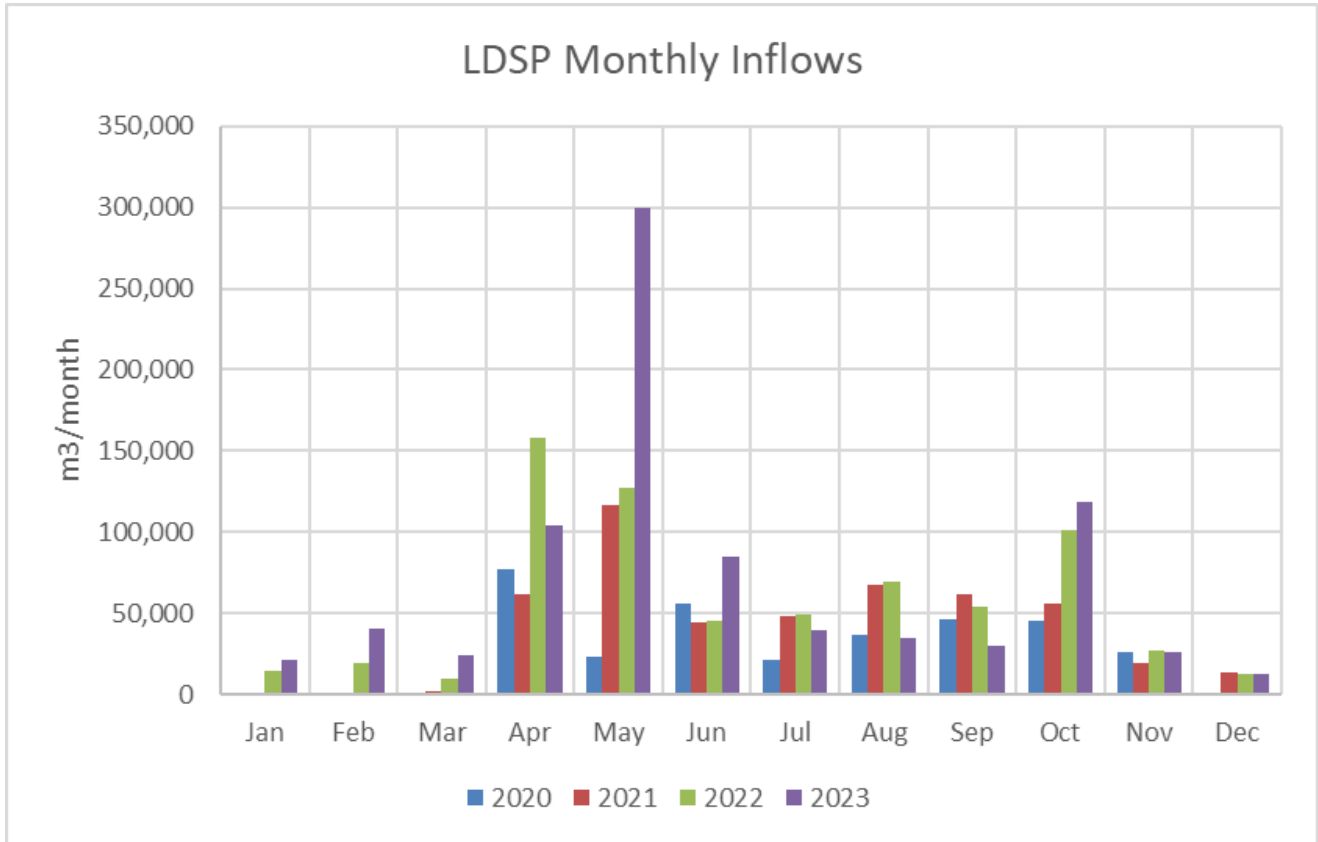

Figure 6.3-1: 2020-2023 Monthly LDSP Inflows

Breaking the data into seasonal groups, it is evident that, and as expected, the total LDSP wintertime inflows are the lowest of the year compared to the 2-month freshet period (Apr 1 to May 31) and the five-month summer/fall period (Jul 1 to Oct 31). Also, the last three years have shown a systematic increase in inflows for each season (Figure 6.3-2). Further, in the last two years, the total influx was still greater than a safe-holding capacity for the LDSP, resulting in a series of pump-outs to the EP or to MWTP/Haggart Creek (two in 2021-2022 totaling over 60,000 m³ and five in 2022-2023 totaling over 146,000 m³ (Table 6.3-3). Thus, there is ample precedence for the need to pump the LDSP down during wintertime to achieve pre-freshet target capacities.

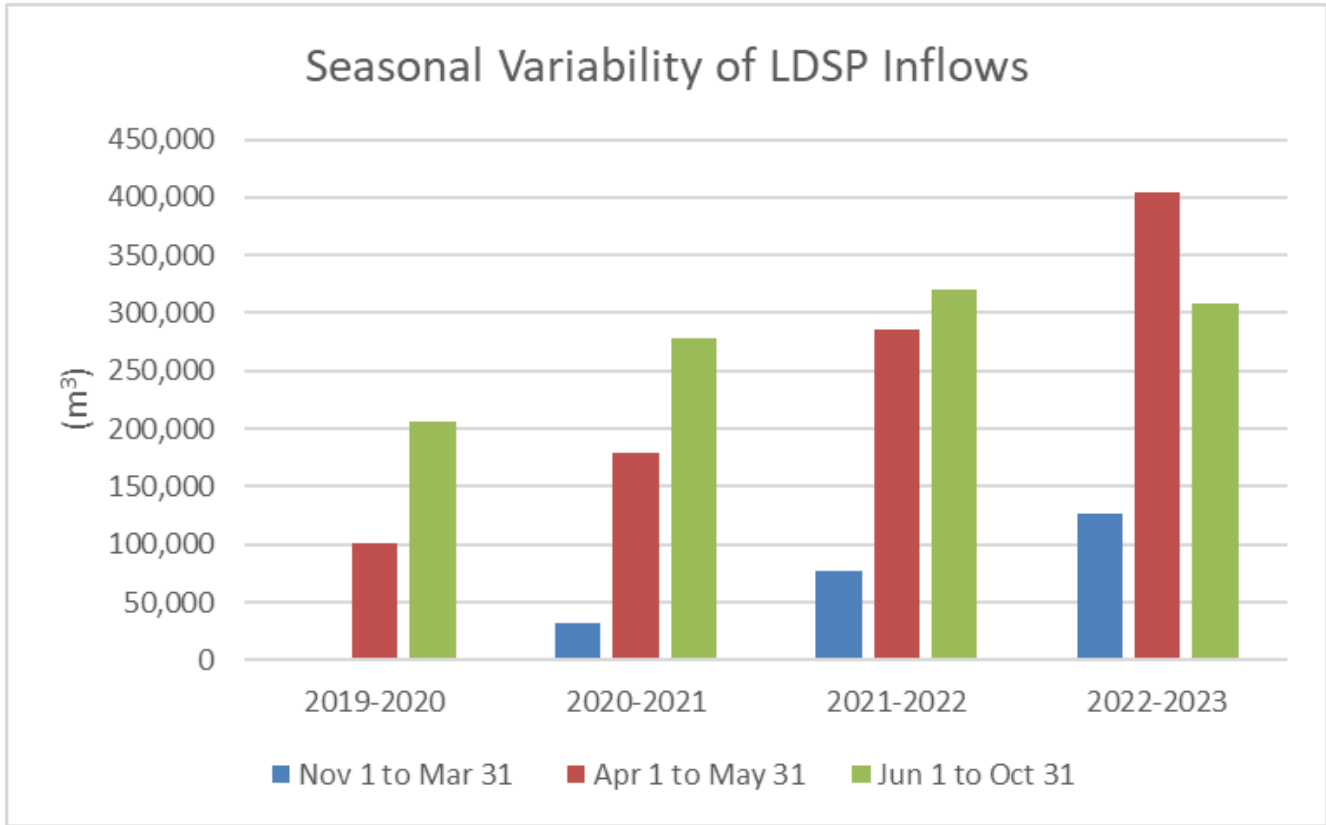

Figure 6.3-2: Seasonal Variability of LDSP Inflows 2020-2023

Table 6.3-3: Comparison of Wintertime LDSP Pump-Outs 2021-2023

Timeline	LDSP Volume		Total Pumped (m³)
	Before Pump (m³)	After Pump (m³)	
Nov 2021	47,330	17,258	30,072
Feb-Mar 2022	37,101	6,626	30,475
Total Pumped 2021-2022			60,547
Nov 2022	63,488	8,994	54,494
Jan 2023	44,554	15,173	29,381
Feb 2023	31,548	12,331	19,217
Feb-Mar 2023	26,702	10,167	16,535
Mar 2023	24,916	16,682	8,234
Mar-Apr 2023	28,702	10,306	18,396
Total Pumped 2022-2023			146,257

Additional considerations for managing LDSP pre-freshet volumes are the minimum pond levels that have previously occurred. Since 2020, the lowest pond volume of 6,630 m³ occurred on Mar 31, 2022, while the annual minimum wintertime levels have ranged from 6,630 m³ to over 22,000 m³, with the last two years likely more representative of conditions moving forward (Table 6.3-4). The November 1 pond volume will also have a factor

in evaluating how to approach the management of LDSP volumes. The expected wintertime influx into the pond should be added to the November 1 pond volume, to estimate how much water should be transferred to the EP for process water demands and how much water will need to be transferred to the MWTP. Based on the previous annual LDSP volume minimum, the expected heap water consumption over winter, and the expected large influx into the pond during freshet, ~400,000 m³ in 2023, the LDSP Pre-Freshet Target (achieved by Mar 31) should be ≤ 10,000 m³.

Table 6.3-4: Comparison of LDSP Pond Volume Minimums and Pump-Outs 2020-2023

	2020 - 2021	2021 - 2022	2022 - 2023
November 1	22,183	29,090	55,020
Winter minimum (November 1 - March 31)	22,183	6,626	8,994
March 31	26,974	6,626	28,302
Annual Minimum	12,802 (October 23)	6,626 (March 31)	7,207 (April 25)
Number of LDSP wintertime pump outs	0	2	5

6.3.1.3 Freshet Readiness

During freshet it is expected that in any given three-day period, cumulative inflows of over 30,000 m³ are considered normal, while they have amounted to over 80,000 m³, well above LDSP capacity on occasion (Table 6.3-5). The only way to address these volumes is to either transfer water to the EP or HLF/ADR or to discharge water through the MWTP (as LDSP water quality is expected to be above EQS during freshet) to Haggart Creek. Pumping capacities then become critical considerations. This is discussed further in Section 6.3.4.

Table 6.3-5: Top 15 3-Day Freshet LDSP Inflows

Rank	Date (yyyy-mm-dd)	3-Day Camp Precipitation (mm)	3-day Inflow (m ³)
1	2023-05-07	0.4	82,933
2	2023-05-02	7.0	67,645
3	2023-05-08	0.4	61,204
4	2023-05-06	0.2	60,846
5	2023-05-03	12.1	54,567
6	2023-05-01	7.0	47,127
7	2022-05-03	0.3	42,020
8	2022-05-02	0.1	40,682
9	2022-05-04	0.2	34,930
10	2022-05-01	0.2	34,729
11	2023-04-22	0.0	34,392
12	2022-04-29	0.1	33,471
13	2022-04-28	0.0	32,723
14	2023-05-12	0.0	31,432
15	2022-04-27	0.0	30,599

6.3.2 EP Inflows and Pond Levels

Assuming no upset conditions (no IHP overflows), then assessing future EP levels depends on season and process make-up water demands, while also maintaining DAS within a 30-day period. Prior to 2023, the MWTP was not available, such that the EP served as a major water retention facility for water transferred from the LDSP. As a result, EP levels were on occasion at high levels (Figure 6.3-3) to allow sufficient time for settling prior to discharge as well as provide the primary source for process make-up water. With the commissioning of the MWTP, EP levels can now be maintained at lower levels throughout the year (by utilizing the MWTP) and still meet process demands for make-up water. However, since the main water source has been from LDSP transfers, managing for the potential freshet influx from the LDSP and the HLF-UMV is still critical.

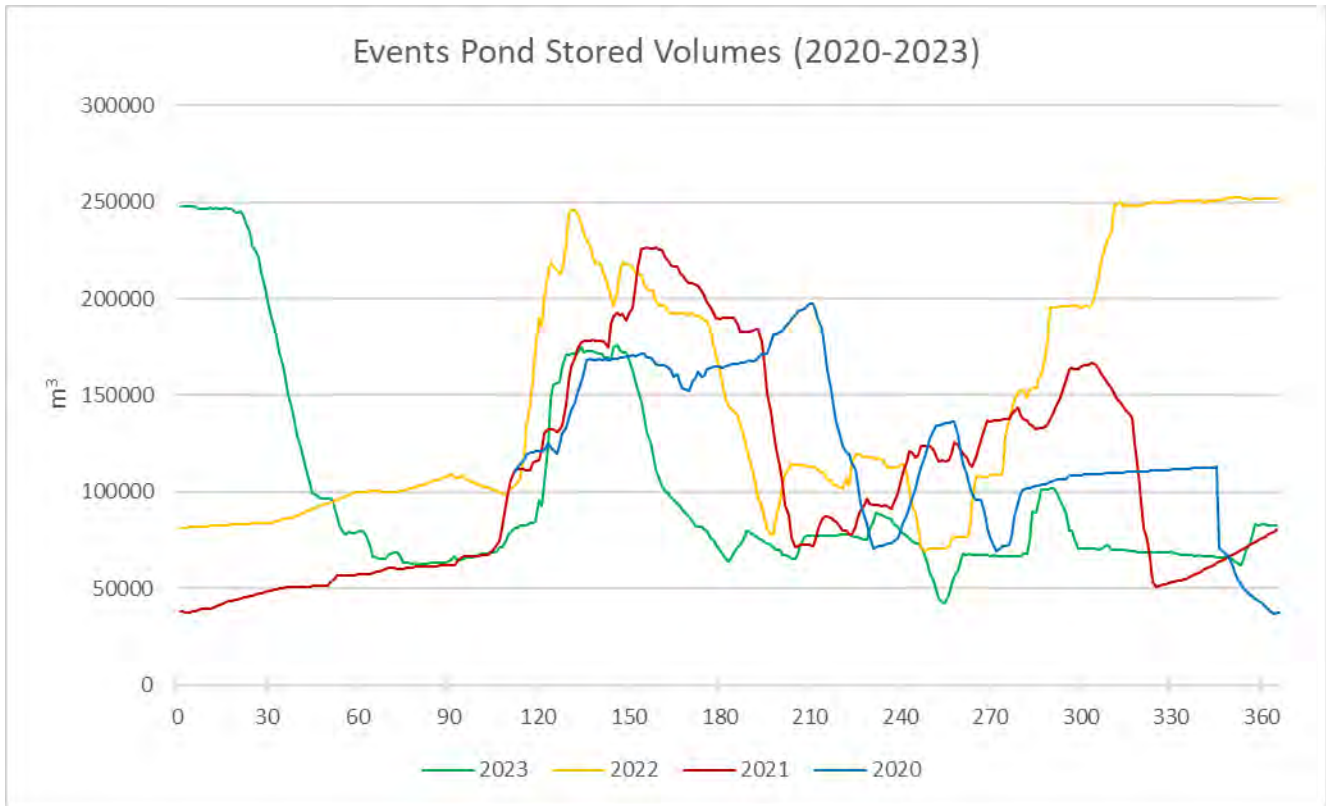

Figure 6.3-3: 2020-2023 Events Pond Levels

For pre-freshet season, the target should consider the total estimated transfers from LDSP and the total HLF UMV inflows throughout winter (Nov 1 to Mar 31), while considering potential process water use. Over the last three winters, the total flow into the LDSP has increased from 32,000 m³ in 2020-2021 to over 120,000 m³ in 2022-2023. Two main factors have contributed to this increase: 1) the input from Ditch B (added in summer 2021) and 2) the increase in flows from the HDHs associated with pit depressurization. From a water management perspective, pit depressurization will continue for a few more years, thus only the last year should be considered as representative for gauging future wintertime inflows to the LDSP, or an assumed influx of over 120,000 m³ (Table 6.3-6).

Similarly, over the last three winters (Nov 1 to Mar 31), the total flow into the Events Pond from the HLF-UMV has ranged from ~19,000 m³ to ~31,000 m³. While vault flows were greatest during the first year after construction (reflecting the effect of the initial construction of drains below the pad), vault flows have varied substantially less since then. Excluding the first year, while there is some seasonal variability (lowest during February through May, and higher during the rest of the year), the monthly inflows have been relatively small (ranging from 2,500 m³/mo to 6,800 m³/mo) compared to monthly transfers from the LDSP (Table 6.3-6 and Figure 6.3-4). For the remainder of the year, and especially during freshet, vault flows have represented a relatively small fraction of the inflow.

Table 6.3-6: Seasonal Variability of LDSP and HLF-UMV Inflows

Hydrologic Year (Nov 1 to Oct 31)	Nov 1 to Mar 31		Apr 1 to May 31		Jun 1 to Oct 31	
	LDSP	HLF UMV	LDSP	HLF UMV	LDSP	HLF UMV
2019-2020			100,600		206,900	62,900
2020-2021	32,400	30,900	178,400	7,600	278,400	29,000
2021-2022	78,100	19,100	286,200	5,600	320,200	25,200
2022-2023	124,200	27,200	399,400	6,000	308,200	21,500

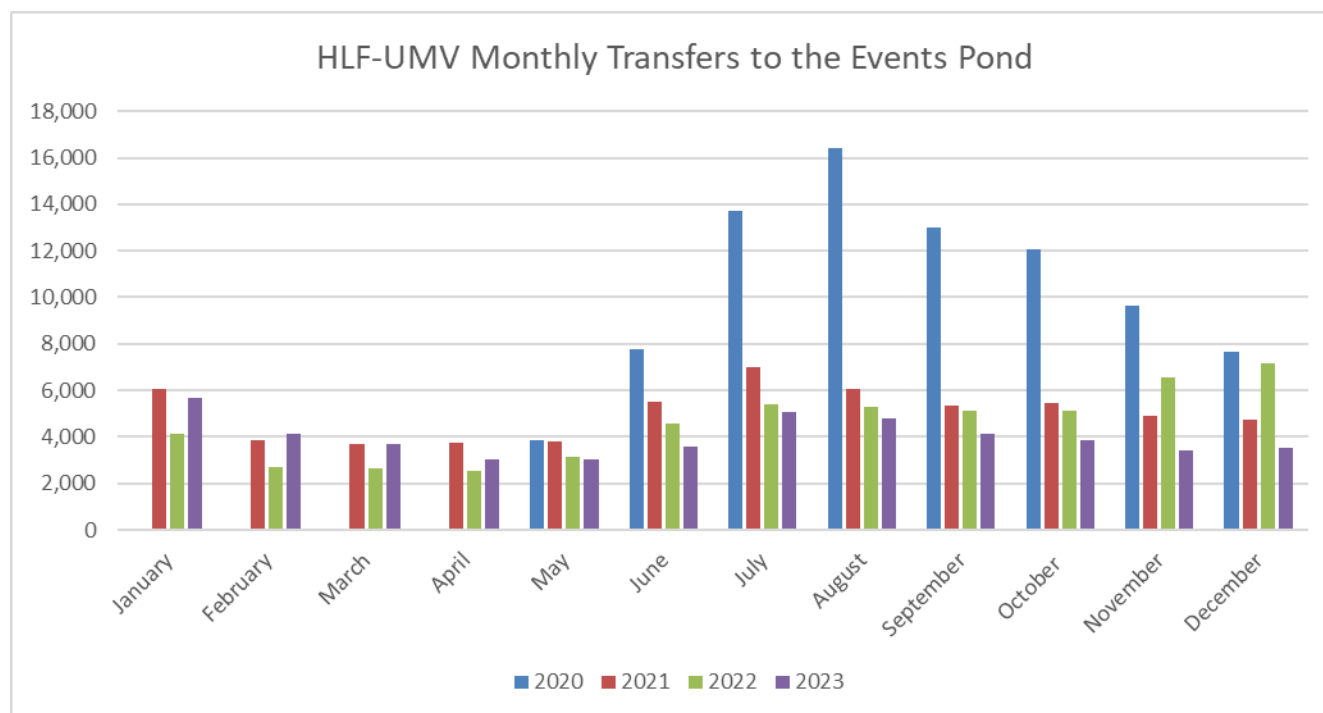

Figure 6.3-4: Comparison of 2020-2023 HLF-UMV Monthly Transfers to the Events Pond

Water use rates (L/tonne) have varied considerably on a monthly and annual basis over the last four years. The annual average has ranged from 30 to 66 L/tonne (Table 6.3-7), while monthly averages have ranged from as

low as 5 L/tonne to over 280 L/tonne (Table 6.3-8). However, the long-term water use rate has been relatively stable since the end of 2021 at 39 L/tonne.

Table 6.3-7: Comparison of 2020-2023 Annual Production, Water Use and Water Use Rates

Year	Ore Production (tonnes)	Water Use (m ³)	Water Use Rate (L/tonne)
2020 (from July 23)	3,885,000	255,100	66
2021	9,157,000	275,800	30
2022	6,624,000	236,000	36
2023	8,986,000	361,800	40
Annual	28,652,000	1,128,700	39

Table 6.3-8: Comparison of 2020-2023 Monthly Water Use and Water Use Rates

	2020		2021		2022		2023		Average	
	m ³	L/tonne	m ³	L/tonne	m ³	L/tonne	m ³	L/tonne	m ³	L/tonne
Jan			19,700	212	2,300	9	18,300	25	13,400	82
Feb			2,400	21	21,700	282	51,300	83	25,100	129
March			7,000	11	11,600	22	40,800	52	19,800	28
April			5,500	7	16,800	25	55,000	63	25,800	32
May			28,100	38	64,400	81	21,500	27	38,000	49
June			50,100	57	28,000	35	62,500	76	46,900	56
July	7,600	51	31,400	27	17,200	26	37,600	47	28,700	33
Aug	36,600	50	32,600	29	40,700	63	27,200	41	33,500	45
Sept	24,200	34	34,600	38	13,700	18	11,500	13	19,900	23
Oct	47,900	63	35,400	38	9,800	21	12,900	21	19,400	36
Nov	68,100	127	21,500	24	3,000	5	8,800	11	25,300	42
Dec	70,800	69	7,500	11	6,700	21	14,400	22	24,900	31
Annual	255,200	66	275,800	30	235,900	36	361,800	40		39

The variability in water use has been due to the stage in HLF phase (during ramp-up a large volume of water was used) timing and availability of water (large influx occurs typically in freshet), fluctuations in the IHP (due to primarily leach area and gold processing needs) and the monthly variability on ore production (typically lower in winter). Since the end of 2022, monthly water use rates have generally increased compared to previous years (Figure 6.3-6) and the total water use in 2023 was greater than any previous year, perhaps reflecting that the HLF leach area has finally reached full size, and that Phase 2 stacking has resulted in a higher water demand due to an increase in the overall depth of the ore column across the pad.

Section 6 Mine Water Management Implementation

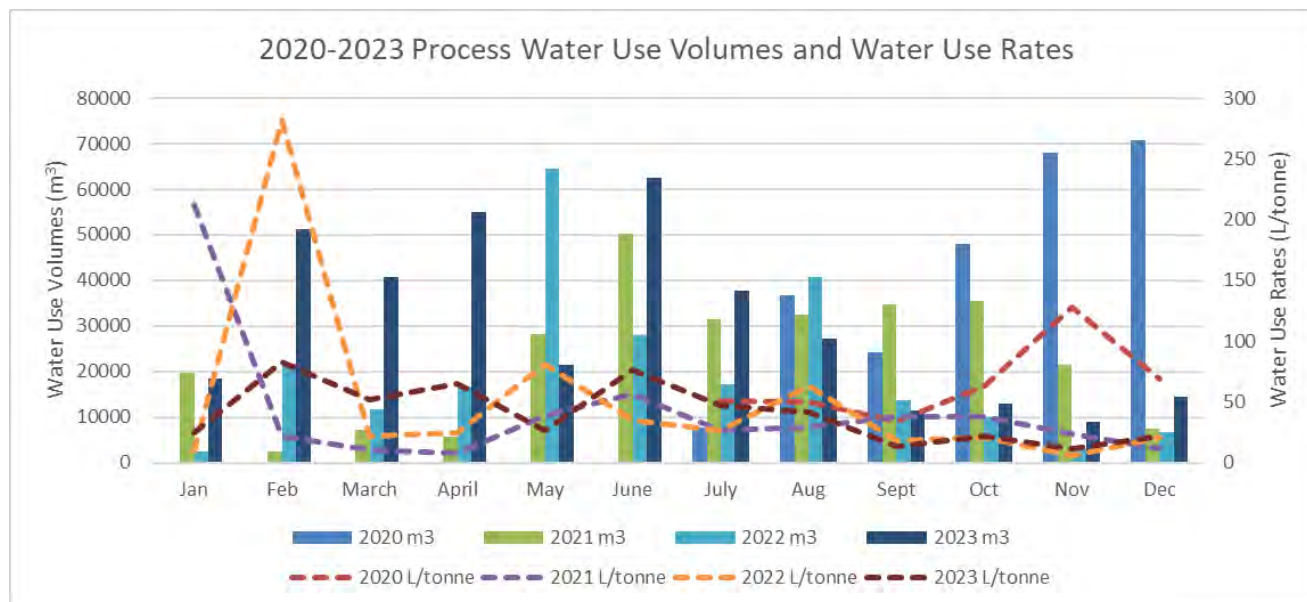

Figure 6.3-5: Comparison of 2020-2023 Monthly Process Water Use Volumes and Rates

From a water management planning perspective and for determining the pre-freshet target for the EP, it is reasonable to assume the long-term average water use rate of 39 L/tonne rather than a monthly average simply because there is no apparent seasonality to the rate. However, except for the first period of November 2020 to March 2021, it is clear based on the last three years of water data collected, the total water used by the ADR/HLF has only been a fraction (18% to 79%) of the total water sourced from the LDSP and HLF UMV (Table 6.3-9). The proportion is greater during the winter (66-79%), and lower during freshet (18-28%). The excess water has been discharged to Haggart Creek (either directly or through the MWTP - see Section 6.1.3). Thus, from a planning perspective, the same seasonal proportionality pattern should be considered when establishing water management targets.

During every season, it should be expected that discharges through the MWTP will be necessary, however, the key will be to manage the total discharged to maximize the use of available water for process need and minimize the use of groundwater, while managing decisions based on water management targets.

Table 6.3-9: Seasonal Variability in Water Sources and Water Use

Hydrologic Year (Nov 1 to Oct 31)	Nov 1 to Mar 31			Apr 1 to May 31			Jun 1 to Oct 31		
	LDSP + UMV Inflows (m³)	ADR/HLF Water Use (m³)	Water Use/Inflow (%)	LDSP + UMV Inflows (m³)	ADR/HLF Water Use (m³)	Water Use/Inflow (%)	LDSP + UMV Inflows (m³)	ADR/HLF Water Use (m³)	Water Use/Inflow (%)
2019-2020				100,600			269,800		
2020-2021	63,300	160,900	254	186,000	33,600	18	307,400	184,100	60
2021-2022	97,200	64,500	66	291,800	81,200	28	345,400	109,500	32
2022-2023	151,400	120,100	79	405,400	76,500	19	229,700	151,800	66

6.3.3 In-Heap Pond Levels

The management of the IHP is governed primarily by ore leaching and gold production requirements, while also considering where the IHP level should be to accommodate the freshet influx. Prior to the last three freshets (2021-2023), the IHP level was reduced to between 924.7 m (9,394 m³) and 927.4 m (15,369 m³); however, the minimums observed have not necessarily been associated with pre-freshet/freshet readiness.

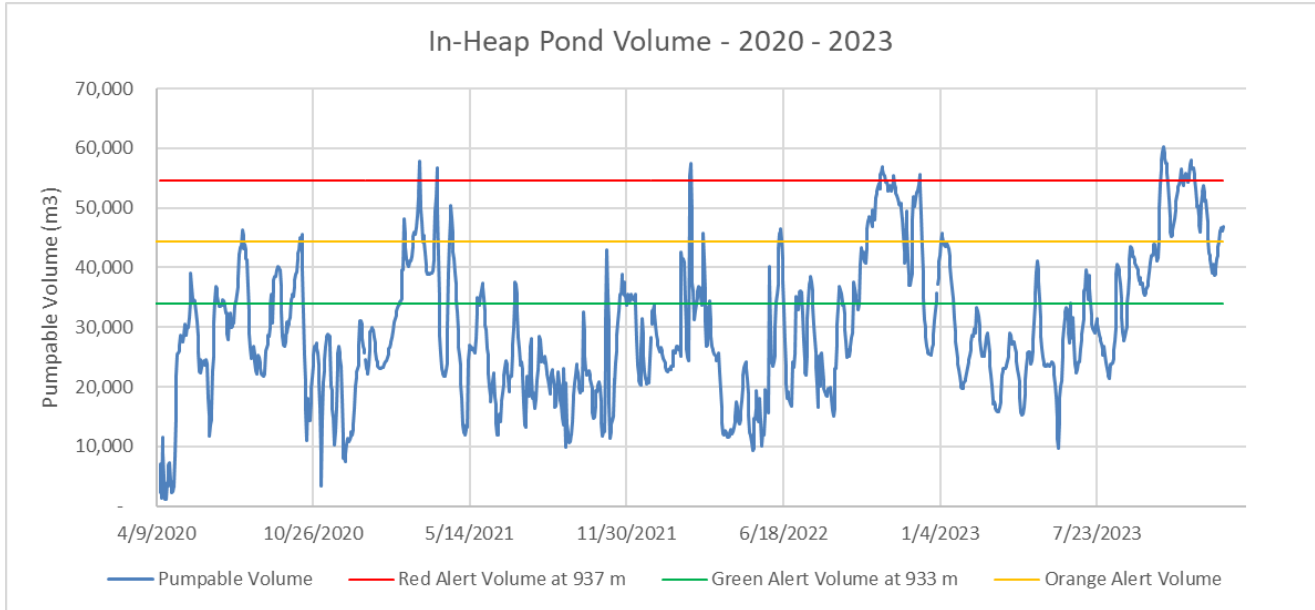

Figure 6.3-6: In-Heap Pond Levels 2020-2023

The IHP T1, T2 and T3 targets (34,030 m³ at 933.56 m, 43,466 m³ at 935.00 m and 54,626 m³ at 937.00 m, respectively) are based on heap operations as described in the OMS.

6.3.4 Historical Capacities for Pumping and Transferring Water

The ability to route water between key water management facilities has been an important water management component since production began. Table 6.3-10 summarizes the maximum daily and 7-day pumping totals for each possible transfer route over the last three years.

For planning purposes, and to help establish expected pumping targets, which in turn provide the basis for water management pond targets, it is logical to assume that at any given day, future estimates of the maximum assumed combined pumping capacities for transferring water from the events pond and the control pond can be approximately 7,000 m³/day and 24,000 m³/day, respectively. In combination with the maximum observed daily capacity of the MWTP to date (11,450 m³/day), that suggests that maximum transfer rates out of the LDSP are around 25,000 m³/day. Similarly, the maximum capacities for any given week can be expected to be approximately 61,000 m³/week and 87,000 m³/week, for the events pond and LDSP respectively when transfers are used in combination with MWTP discharge. These weekly rates represent approximately 21% and 145% of the existing pond capacities. This means that the LDSP can be drawn down fairly quickly in response to large rainfall-runoff or freshet snowmelt events, provided there is ample available storage in the EP and the MWTP is operating at full capacity. During 2023, the maximum weekly flow to the MWTP was over 65,000 m³, which is

slightly over (1.1 times) the current LDSP capacity of 60,000 m³. These data indicate that to manage freshet inflows, full pumping capacities are needed while ensuring the MWTP is also operational.

Table 6.3-10: 2021-2023 Maximum Daily and 7-Day Pumping Totals for Each Possible Transfer Route

Possible Pumping Transfer Routes	2021		2022		2023	
	Max 24-hr	Max 7-Day	Max 24-hr	Max 7-Day	Max 24-hr	Max 7-Day
EP to ADR	16,667	16,667	2,452	14,346	5,000	16,873
EP to HLF/IHP	22,272	23,786	2,688	12,308	1,170	2,295
EP to CP	0	0	0	0	4,800	33,600
<i>Total Transferred out of EP</i>	<i>22,272</i>	<i>23,786</i>	<i>4,938</i>	<i>23,806</i>	<i>7,200</i>	<i>49,964</i>
CP to ADR	9,967	9,967	1,756	4,017	3,234	16,491
CP to HLF/IHP	0	0	10,000	18,400	7,016	15,200
Metered CP to EP	0	0	8,880	23,516	3,600	20,325
Unmetered CP to EP	0	0	16,595	87,197	23,894	73,859
<i>Total Transferred out of CP</i>	<i>9,967</i>	<i>9,967</i>	<i>19,112</i>	<i>87,197</i>	<i>24,228</i>	<i>75,716</i>
Deep Well to ADR	751	3,125	432	1640	638	4,216
Total to ADR/HLF/IHP	0	0	10,239	23,806	7,828	28,099
<i>Total to MWTP</i>	<i>0</i>	<i>0</i>	<i>0</i>	<i>0</i>	<i>11,450</i>	<i>65,458</i>

6.3.5 Selection of WMP Targets and Actions

Based on the analysis presented above, the pre-freshet and summer/fall targets for each pond are summarized in Table 6.3-11. Recommended actions once targets are reached are summarized in Table 6.3-11.

Table 6.3-11: Water Management Pond Targets

Pond	Total Capacity (m ³)	Pre-Freshet Targets		Target 1		Target 2		Target 3	
		Pre-Freshet Capacity (m ³)	March 31 Stored Volume (m ³)	T-1 Action Capacity (m ³)	Normal Stored Volume (m ³)	T-2 Action Capacity (m ³)	Available Stored Volume (m ³)	T-3 Alert Capacity (m ³)	Maximum Stored Volume (m ³)
Phase 2 and Bathymetric Update September 2022									
				10-yr 24 hr runoff		5-yr 24 hr runoff		2-yr 24 hr runoff	
Control Pond	60,103	50,103	10,000	26,249	33,854	22,795	37,308	17,269	42,834
				> 200-yr 24 hr runoff		DAS: 100-yr 24 hr runoff		10-yr 24 hr runoff	
Events Pond	292,056	230,056	62,000	217,056	75,000	196,343	95,713	139,573	152,483
				Green Alert		Orange Alert		Red Alert	
In-Heap Pond	57,763	27,763	30,000	23,733	34,030	14,297	43,466	3,137	54,626
All Ponds	409,922	307,922	102,000	267,038	142,884	233,435	176,487	159,979	249,943
Phase 2 and Ponds Clean									
				10-yr		5-yr		2-yr	

Eagle Gold Mine
Water Management Plan

Section 6 Mine Water Management Implementation

		Pre-Freshet Targets		Target 1		Target 2		Target 3	
Pond	Total Capacity (m³)	Pre-Freshet Capacity (m³)	March 31 Stored Volume (m³)	T-1 Action Capacity (m³)	Normal Stored Volume (m³)	T-2 Action Capacity (m³)	Available Stored Volume (m³)	T-3 Alert Capacity (m³)	Maximum Stored Volume (m³)
Control Pond	68,522	58,522	10,000	26,249	42,273	22,795	45,727	17,269	51,253
				>200-yr		DAS: 100-yr		10-yr	
Events Pond	300,577	238,577	62,000	225,577	75,000	196,343	104,234	139,573	161,004
				Green Alert		Orange Alert		Red Alert	
In-Heap Pond	57,763	37,763	30,000	23,733	34,029	14,297	43,466	3,137	54,626
All Ponds	426,862	324,862	102,000	275,559	151,302	233,435	193,427	159,979	266,883
Phase 3 and Bathymetric Update September 2022									
				10-yr		5-yr		2-yr	
Control Pond	60,103	50,103	10,000	26,249	33,854	22,795	37,308	17,269	42,834
				>200-yr		DAS: 100-yr		10-yr	
Events Pond	292,056	237,056	55,000	224,056	68,000	211,953	80,103	139,573	152,483
				Green Alert		Orange Alert		Red Alert	
In-Heap Pond	57,763	27,763	30,000	23,733	34,029	14,297	43,466	3,137	54,626
All Ponds	409,922	314,922	95,000	274,038	135,883	249,045	160,877	159,979	249,943
Phase 3 and Ponds Clean									
				10-yr		5-yr		2-yr	
Control Pond	68,522	58,522	10,000	26,249	42,273	22,795	45,727	17,269	51,253
				>200-yr		DAS: 100-yr		10-yr	
Events Pond	300,577	245,577	55,000	232,577	68,000	211,953	88,624	139,573	161,004
				Green Alert		Orange Alert		Red Alert	
In-Heap Pond	57,763	27,763	30,000	23,733	34,029	14,297	43,466	3,137	54,626
All Ponds	426,862	331,862	95,000	282,559	144,302	249,045	177,817	159,979	266,883

Table 6.3-12: Water Management Actions when Triggers are Reached

<i>Facility</i>	<i>Normal Operations</i>	<i>Evaluate by Nov 1 PFTs</i>	<i>Evaluate by March 31 PFTs</i>	<i>Target 1</i>	<i>Target 2</i>	<i>Target 3</i>
LDSP	<ol style="list-style-type: none"> 1. Retain inflows from Ditches A and B 2. Transfer to EP until EP-T1 is reached 3. Transfer to HLP until IHP-T1 is reached 	<ol style="list-style-type: none"> 1. Estimate long-term (to March 31) inflows to LDSP 2. Project LDSP pond level to March 31 3. If projected level exceeds LDSP-PFT, consider transfer to EP or MWTP 4. Collect LDSP WQ samples to prepare for direct discharge or transfer to MWTP 	<ol style="list-style-type: none"> 1. Retain inflows from Ditches A and B 2. Transfer to EP until PFT is reached or until EP-T1 is reached 3. Collect instream samples for control/background and LDSP WQ samples to confirm EQS are met 4. If EQS not met, Transfer to MWTP 	<ol style="list-style-type: none"> 1. Retain inflows from Ditches A and B 2. Transfer to EP until EP-T1 is reached 3. Transfer to IHP until IHP-T1 is reached 4. Collect instream samples for control/background and LDSP samples for input to MWTP operations 5. If EQS not met, Transfer to MWTP 	<ol style="list-style-type: none"> 1. Retain inflows from Ditches A and B 2. Transfer to EP until EP-T2 is reached 3. Transfer to IHP Until IHP-T2 is reached 4. Collect instream samples for control/background and LDSP samples to confirm EQS are met 5. If EQS not met, transfer to MWTP 	<ol style="list-style-type: none"> 1. Retain inflows from Ditches A and B 2. Collect instream samples for control/background and LDSP samples to confirm EQS are met 3. If EQS not met transfer to MWTP 4. Transfer to EP until EP-T3 is reached
Events Pond	<ol style="list-style-type: none"> 1. Retain meteoric inflows and transfers from UMV and LDSP 2. Transfer to ADR or HLP 3. Maintain pond level below EP-T1 	<ol style="list-style-type: none"> 1. Estimate long-term (to March 31) inflows from UMV, LDSP and rain/snowmelt 2. Estimate long-term (to March 31) water use rate 3. Project EP pond level to March 31 4. If projected level exceeds EP-PFT, collect EP WQ samples and prepare for transfer to MWTP 5. If EP WQ samples meet EQS discharge direct, if EP WQ samples exceed EQS transfer to MWTP 	<ol style="list-style-type: none"> 1. Retain meteoric inflows and transfers from UMV and LDSP 2. Cease transfers from LDSP when PFT is reached 3. Transfer to ADR or HLP until IHP-PFT is reached 4. Consider increasing leach areas and production rate 5. Collect EP WQ samples 6. Consider direct transfer to MWTP 	<ol style="list-style-type: none"> 1. Retain meteoric inflows and transfers from UMV and LDSP 2. Increase transfers to ADR or HLP until IHP-T2 is reached 3. Consider increasing leach areas and production rate 	<ol style="list-style-type: none"> 1. Retain meteoric inflows and transfers from UMV 2. Reduce or eliminate transfers from LDSP 3. Increase transfers to ADR or HLP until IHP-T3 is reached 4. Confirm DAS - Utilize operating conditions to calculate DAS considering both IHP and EP capacities and the 7-day running average barren pumping rate 5. Cease any transfers from the Deep Well to ADR/IHP 6. Collect EP WQ samples 7. Transfer to MWTP if LDSP-T2 is reached after DAS recalculation 8. Consider transfers back to LDSP and/or direct to MWTP if storage made available after MWTP discharges 	<ol style="list-style-type: none"> 1. Cease any transfers from LDSP 2. Continue to retain transfers from UMV 3. Maximize leach areas and production rate 4. Continue to collect EP WQ samples 5. Maximize flow to MWTP
In-Heap Pond	<ol style="list-style-type: none"> 1. While considering projected production rates 	<ol style="list-style-type: none"> 1. While considering projected production rates 	<ol style="list-style-type: none"> 1. While considering projected production rates 	<ol style="list-style-type: none"> 1. While considering projected production 	<ol style="list-style-type: none"> 1. While considering recalculated DAS and 	<ol style="list-style-type: none"> 1. Cease any transfers from EP and/or LDSP

Section 6 Mine Water Management Implementation

Facility	Normal Operations	Evaluate by Nov 1 PFTs	Evaluate by March 31 PFTs	Target 1	Target 2	Target 3
	maintain barren and pregnant pumping rates to operate below IHP-T1 pond level on a 7-day running average	maintain barren and pregnant pumping rates to operate below IHP-T1 pond level on a 7-day running average 2. Estimate long-term (through winter) inflows from all sources (EP, LDSP, Deep Well, rain/snowmelt) 3. Estimate weekly water use rates based on projected weekly production rates 4. Project IHP levels to March 31	maintain barren and pregnant pumping rates to operate below IHP-PFT pond level on a 7-day running average 2. Estimate inflows from all sources through freshet 3. Estimate weekly water use rates based on projected weekly production rates 4. Project IHP levels through freshet	rates adjust barren and pregnant pumping rates and leach areas (dynamic storage) to operate below IHP-T1 pond level on a 7-day running average	projected production rates, adjust barren and pregnant pumping rates and leach areas (dynamic storage) to operate below IHP-T2 pond level on a 7-day running average	2. Increase leach areas (dynamic storage) 3. Maximize production rates
Mine Water Treatment Plant	1. Offline	1. Initiate Pre- Operations Checklist two weeks prior to discharge 2. Confirm EQS are met and discharge to HC 3. Based on instream flows and pond WQ samples, adjust inflows from LDSP and/or EP to meet WQOs as needed	1. Initiate Pre- Operations Checklist two weeks prior to discharge 2. Confirm EQS are met and discharge to HC 3. Based on instream flows and pond WQ samples, adjust inflows from LDSP and/or EP to meet WQOs as needed	1. Initiate Pre- Operations Checklist two weeks prior to anticipated discharge date 2. Confirm EQS are met and discharge to HC 3. Based on instream flows and pond WQ samples, adjust inflows from LDSP and/or EP to meet WQOs as needed	1. Continue operate WTP and increase throughput rate if WQO's can still be achieved	1. Maximize pumping rates while confirming EQS and WQOs are met 2. If WQOs not met, consider use of emergency pond, while maximizing WTP usage

6.4 OTHER WATER MANAGEMENT STRUCTURES

6.4.1 Culverts

Figure 6.1-1 depicts eight watercourse crossings along site roads. Culverts are sized to convey the 1 in 10-year 24-hour storm event for temporary crossings, the 1 in 100-year 24-hour storm event for crossings with a catchment area larger than 1 ha, and the 1 in 200-year 24-hour storm event for stream crossings (i.e., Dublin Gulch and Eagle Creek).

The culverts consist of corrugated metal pipe installed according to the manufacturer's specifications and are sized as shown in Table 6.4-1. Culverts are embedded in gravel and/or constructed with baffles for those crossings where fish passage occur.

The hydrologic model described in Section 5.4 was used to predict the design flows for each crossing. The culverts were sized using standard culvert nomographs and the PCSWMM modelling software.

Table 6.4-1: Culvert Specifications

Culvert ID	Catchment Area (Ha)	Design Criteria	Total Rainfall Depth (mm)	Rainfall Distribution	Peak Intensity (mm/h)	Design Flow (m ³ /s)	Length (m)	Slope	Diameter (mm)	# of pipes
1	422.2	IDF from Emergency Spillway	94.0	Type 2	104.3	24.0	28	2.4%	2200	2
2	860.9	1 in 200-year, 24-hour	78.2	Type 2	86.8	4.3	49	5.7%	1200	2
3	846.7	1 in 10-year, 24-hour	49.1	Type 2	54.5	0.3	30	8.7%	750	1
4	836	1 in 200-year, 24-hour	78.2	Type 2	86.8	4.2	58	2.7%	1200	2
5	11.2	1 in 200-year, 24-hour	78.2	Type 2	86.8	1.2	44	7.1%	800	1
6	166.2	1 in 200-year, 24-hour	78.2	Type 2	86.8	1.0	40	7.1%	750	1
7	653.2	1 in 200-year, 24-hour	78.2	Type 2	86.8	3.1	78	7.1%	900	2
8	133.8	1 in 100-year, 2-hour	71.6	Type 2	79.4	5.3	56	3.0%	1200	2
9	n/a	IDF from Emergency Spillway	94.0	Type 2	104.3	24.0	28	2.4%	2200	2

6.4.2 Pipes

A series of non-perforated pipes are utilized within the pit and 90-day stockpile and are installed to capture and direct contact water from the areas to the major site ditches. Based on the current configuration of the pit, the water transferred by this configuration is primarily from the outlets of the horizontal drain holes installed in the pit walls to aid with depressurization. As the pit reaches elevations where a true sump area can be developed, it is expected that trash pumps will be connected to this pipe system to ensure that water does not accumulate in active mining areas. Any contact water that accumulates within the sump will then flow through the pipes to Ditch A or B and to the LDSP for use as process make up water or will be released to Ditch C in accordance with the discharge standards specified in QZ14-041-1.

6.4.3 Evaporators

Another water management tool that has been deployed on the site are evaporators. Evaporator units have been, and may continue to be, utilized to shed excess water from the LDSP and the Events Pond if the

water is not required for mine process needs. The evaporators can be deployed on the banks of each pond or the HLF so that any water that is not evaporated is captured within lined containment.

6.5 KEY MINESITE INFRASTRUCTURE

6.5.1 Open Pit

As summarized above in Section 5.6 and described by BGC (2014 and 2019), due to the relatively low hydraulic conductivity of the rock mass in the open pit area, dewatering wells are not considered a practical or economically efficient means of depressurizing all the open pit slopes. As described in Section 3.5.2, beginning in 2021, horizontal drains have been used for depressurizing the pit slopes. These will likely be important to maintain (replace those that have been sacrificed from an interbench location) over the life of the mine to maintain stability of the pit walls and to manage pit wall seepage and most of the inflows. The number and location of horizontal drains is continuously assessed based on field observations and measurements. The water collected from the HDHs is piped to a connection point which can convey water to Ditches A or B.

6.5.2 Heap Leach Facility

The HLF valley fill incorporates an embankment (dam) that provides stability to the base of the heap and the stacked ore. The dam also creates an In-Heap Pond (IHP) leaching configuration that provides storage of pregnant solution within the pore spaces of the ore. For water management perspectives, the HLF is the major water user. The major design components for the HLF, which are incorporated primarily for solution management purposes, include the following:

- a earth/rock filled embankment (dam) and the In-Heap Pond;
- a composite liner system;
- solution recovery wells;
- associated piping network for solution collection and distribution;
- a leak detection and recovery system (LDRS);
- a subsurface (below liner) system for collecting groundwater, conveying to an underground monitoring vault and then transferring to the Events Pond (EP); and
- a down-stream Events Pond.

The heap leach pad consists of two liner systems: an up-gradient liner system and the IHP liner system. The single composite liner system in the upper portion of the pad (above the IHP liner system) is comprised of a double-side textured 60 mil linear low-density, polyethylene (LLDPE) liner over a geosynthetic clay liner (GCL) system. The double composite liner system in the lower portion of the pad (forming the IHP storage area) is composed of two discrete layers of LLDPE liner, separated by a layer of geonet material to form the LDRS, over a GCL system.

Process (barren) solution containing cyanide is applied to the ore via a drip leaching system. The resultant pregnant leach solution (PLS) is captured in the solution collection system and flows to the IHP. The PLS is then recovered via a sump using pumps and standpipes. The PLS is then transferred to the ADR plant for gold recovery.

The heap leach pad (HLP) contains a network of pipes that will be extended throughout the limits of the facility (for Phase 3) at the base of the ore pile. This pipe network is constructed on the liner and under the existing ore pile of Phase 1 and 2 and will be constructed throughout the pad to collect and convey PLS and an infiltrated stormwater to the IHP where it is pumped to the process plant via the solution collection wells.

The HLP is underlain by a HLF-system wide pipe network that is designed to collect groundwater and prevent hydrostatic pressure from lifting the liner. The pipe network eventually reports to an underground monitoring vault (HLF-UMV), where water quality samples can be collected and inflows are metered. The inflows are then pumped up to the EP, where the water is eventually used for process make-up water.

The downstream EP serves two primary functions: 1) as an overflow containment area that provides additional solution storage in case the IHP capacity is exceeded, and 2) as retention storage for process make-up water. Any water collected in the EP can be pumped back to the ADR plant for use as make up water for the barren solution, or transferred to the MWTP in case EP storage volume triggers need to be achieved.

6.5.3 Waste Rock Storage Areas

Runoff and seepage (from subsurface rock drains) from the two waste rock storage areas (PG WRSA and EP WRSA) are conveyed to Ditches A and B. The rock drains connect to the ditches through rock-filled trenches where flow is not visible, which makes it difficult to estimate seepage flow at the seepage outflow. Spot flow measurements are made in these ditches, which by then also includes runoff from the WRSAs as well as springs and overland runoff from both disturbed and non-disturbed areas of the catchment. While the spot flow measurements provide useful data for comparisons and understanding the seasonality of the flows, the total flows from both ditches is accounted for at the LDSP (LDSP inflows includes all runoff and seepage from the WRSAs).

6.6 EROSION AND SEDIMENT CONTROL PLAN IMPLEMENTATION

This section provides an overview of the current configuration of erosion and sediment control measures based on the BMPs described in Section 4.2 (Sediment and Erosion Control Measures) to support operations. As the Mine advances through the operations phase, some of the configuration may be reconsidered based on site observations and areas of activity.

For the purpose of this Plan, the following BMPs have been utilized during construction and operations, and will continue to be utilized moving forward:

- Proper staging of construction activities and BMP installations to mitigate erosion and the potential entrainment of sediment.
- Installed berms or diversion ditches at the top of fill slopes to protect the newly formed slopes from erosion.
- Applied seeding efforts for slope stabilization and channel protection as necessary along ditches, and on unstable and/or disturbed slopes and surfaces.
- Applied slope stabilization and channel protection measures as necessary, along ditches, and on unstable and/or disturbed slopes and surfaces.

- Installed sedimentation mitigation measures including but not limited to silt fences and straw bales around the downslope perimeter of unstable material stockpiles and or highly erodible slopes to prevent sediment migration downslope.
- Installed sedimentation mitigation measures including but not limited to silt fences, spring berms, straw bales upgradient of major water conveyance structures and ditches on site.
- Monitored, maintained, repaired and replaced the mitigating measures listed above throughout the Mine life to ensure BMP effectiveness and efficiency.

6.6.1 Erosion and Sediment Control - Current Status

Erosion and sediment control is ongoing throughout the site to support the overall water management objectives for the Mine and to ensure compliance with the regulatory approvals issued for the Mine. Revegetation and reseeding work in the areas of the LDSP, Ditches A and B, the overland conveyor in the area of the HLF embankment, water crossings and culverts, overburden stockpiles within the Dublin Gulch valley and adjacent to Phase 1 and 2 of the HLF, the Event Pond and HLF embankment itself are ongoing. The status and progression of fall and spring seeding programs are evaluated annually. Additionally, various BMP's have been installed and will be added to, or removed as necessary, during the Operations phase of the Mine.

The following measures, in addition to the key water management facilities discussed in section 6.1, are currently in place to stabilize Mine areas:

- Silt fences downslope of active mining infrastructure including:
 - Ditch A
 - ADR Process Plant Access Road
 - Substation, gensets, and fuel storage area
 - Waste management facility
 - Various overburden stockpiles
 - HLF 1B overburden stockpile
 - LDSP
 - HLF embankment area
 - Events Pond and ADR Plant area.
- Silt fences upslope of mining infrastructure including:
 - Overland Conveyor
 - Ditch A
- Sediment basins in topographical low points downslope of the Coarse Ore Stockpile and 90 Day Stockpile areas.
- Several sediment basins complete with ditching structures downgradient of the Dublin Gulch exploration road and adjacent to the overland conveyor to act as catchment sumps to reduce runoff velocities and sediment loading from area runoff.
- Willow, alder, straw berms have been utilized as bioengineering structures installed adjacent to:
 - Haggart Creek,

- Phase 1B overburden stockpile area
 - LDSP
 - Dublin Gulch
 - ROM road crossings
- Diversion ditches to channel non-contact water away from the following facilities/areas:
 - Upgradient of Phase 2 of the HLF
 - Adjacent to the LDSP to intercept unimpacted groundwater seeps.
 - Upgradient of the overland conveyor
 - Along the ADR access road
- Collection ditches to channel contact water from the following facilities/areas (in addition to Ditches A, B and C):
 - ADR Pad
 - Upgradient of Phase 2 of the HLF
 - Along various site roadways
- Straw bales are installed in Ditch A to help mitigate flow velocities and settle sediment out prior to reaching the LDSP.
- Rock energy dissipation structures at the end of ditches A, B and C where the ditches either tie into the natural drainage or the LDSP. This protects the receiving area from higher velocity flows released from the diversion ditch.
- A large inflow sediment containment berm/trap was designed and installed at the LDSP forebay to mitigate sedimentation within the pond and assist with periodic clean out.
- The Mine roadway near the LDSP was redesigned to route road runoff away from Ditch C so that it could be directed to natural highly vegetated areas
- Vegetation windrows to act as natural barriers downslope of the following facilities/areas:
 - ADR Process Plant Access Road
 - Events Pond
 - 90 Day Stockpile
 - Open Pit access road
 - Camp access road
 - Crusher Pad
 - Substation, gensets, and fuel storage area
 - Waste management facility.

6.6.2 Erosion and Sediment Control - Forward Planning

As mining activities on the Mine advance, there will be new or increased areas of construction and disturbance that will require the installation of additional erosion and sediment control BMPs. Whilst installation of erosion and sediment control BMPs are best determined based on field observations, the following discussion provides the current conceptual plan for additional erosion and sediment control.

- Install silt fences downslope of mining infrastructure including:

Section 6 Mine Water Management Implementation

- HLF eastern access road
 - Eagle Pup WRSA
 - MWTP pad
 - IROSA
-
- Reconfigure as necessary contact water pipe network for 90-day stockpile and open pit;
 - Continue to maintain and reinstall silt fence and sedimentation mitigation measures on site
 - Regularly clean out sumps and sediment basins that require sediment and maintenance.
 - Continue to advance seeding activities across problem erosional areas on the Mine
 - Construct sediment basins, exfiltration areas, and rock energy dissipation structures as required.

6.7 SANITARY WASTEWATER MANAGEMENT

In 2018, an on-site sewage disposal system was installed to support the construction and operations camp for the Mine. The installation has been fully completed and record drawings and, as per the requirements of the Government of Yukon, Environmental Health Services (EHS), photo documentation of the construction were provided by Tetra Tech and JDS Energy and Mining Inc. and submitted to the Yukon Water Board as required by the Type B Water Use Licence QZ16-016. The ongoing operation, maintenance and surveillance of the camp wastewater system is no longer considered part of this Plan.

6.8 WATER USES

Water uses for the Mine include potable water, dust suppression, wash water, process makeup water and to a significantly lesser extent since major construction activities have been complete, making concrete.

As an input to the design and construction phase, potable water consumption was estimated in accordance with the projected population of the camp. Consumption rates were estimated to range from 930 m³/month to 3,720 m³/month, with the more consumptive months occurring during the ice-free season. Since construction began in 2017, potable water has been supplied to the camp from the groundwater well (MW10-DG07) located to the north of the main camp. In 2022 (likely most representative for conditions moving forward), daily usage remained below the authorized daily limit of 157 m³/day, averaging approximately 57 m³/day throughout the year, while ranging between a minimum of 18 m³/day to 110 m³/day. Average monthly water usage rates were greatest in August (69 m³/day) and the least during January (49 m³/day).

Water supply is also needed for drilling and is typically sourced from the Camp Well (PW-JDS18-001) located just north and adjacent to Dorm A. Usage is intermittent throughout each month, ranging from 2.4 m³/month in February to over 135 m³/month in March, with an annual average of 0.9 m³/day. The maximum usage in one day was 17.6 m³/day on March 24, 2022.

Water is also used for dust suppression. Usage peaked in July 2022 with a total consumption of 9,750 m³, or an average daily rate of 315 m³/day. The daily maximum at any given time was 875 m³/day, which was less than the licensed daily allowable usage rate of 908 m³/day.

Wash water includes water to wash trucks and equipment and varies with seasonal activity. Estimated wash water consumption varies from 50 m³/month to 250 m³/month, with highest projected usage in the summer months.

Makeup water for use within the HLF has been sourced either from the LDSP and/or groundwater as needed. 2020-2023 (primarily Phase 1 HLF monthly and annual make-up water uses are discussed in section 6.3.

The HLF WBM predicts that water use rates will generally decline over the operational life of the facility (as the solution inventory increases) as the lined footprint increases and water begins to accumulate in the system. Typical WBM estimated values fall to between 43,000 m³ to 65,000 m³ per month and maximums are approximately 80,000 m³. These are higher than the observed monthly totals, suggesting that the HLF WBM has conservatively overestimated water demand. The frequency at which makeup water demand is zero increases. Makeup water demand is estimated to continue to decline into Phase 3. Although typical modeled values remain between 43,000 m³ to 65,000 m³ per month with similar maximum values each month, the frequency at which makeup water demand is zero again increases.

6.9 FROZEN MATERIAL MANAGEMENT

Continued earthworks construction and some operational activities of the Mine may result in the excavation and exposure of frozen overburden soils, identified as either permafrost or from within the active zone that freezes seasonally. Frozen soils at the Mine site consist of:

- fine and/or coarse-grained colluvial/alluvial soils or weathered bedrock with little or no ice content,
- coarse-grained sands and gravels with zones of variable ice content,
- fine-grained soils with relatively thin zones (lenses) and low proportions of “excess ice”, and
- fine-grained silty and clayey soils with relatively thick lenses of highly visible “excess ice”.

The term “excess ice” is used to describe ice that occupies a larger pore space in the soil than water in an unfrozen state. When this ice thaws, the resulting water exceeds the water holding capacity of the soil and excess water will be present. Some of the frozen soil with excess ice, hereafter called “ice rich”, may become unstable upon thawing, particularly if it is fine-grained and excess pore water pressure cannot drain readily. Some of these materials, which could potentially be useful in closure activities (e.g., as cover for reclamation) while thawing and draining, may require temporary containment during construction and operation of the mine.

The Frozen Materials Management Plan (FMMP) describes the management of frozen materials, and includes:

- descriptions of existing site conditions pertinent to materials management;
- protocols for characterizing the nature and extent (lateral and vertical) of frozen materials encountered during construction activities including characterizing the presence and extent of excess ice;
- protocols for determining whether encountered frozen material is thaw stable or thaw unstable;
- estimated quantities of frozen materials to be handled during construction distinguishing between material types and different approaches for their management;
- descriptions of appropriate handling requirements for each frozen material type, including protocols for excavation and removal of thaw unstable material from drainage channels, valley walls, etc.;
- design criteria and preliminary engineering for an ice rich overburden storage area;
- construction quality assurance and quality control planning for the ice rich overburden storage area;
- protocols for recording and reporting on the characterization and management of frozen soils (including thaw stable and unstable materials), and
- monitoring plans for stability and associated water management.

Because of the nature of thawing frozen material and the potential for generation of sediment-laden water, the activities associated with the FMMP have been integrated into the overall site Water Management Plan. While the FMMP addresses the identification, field practices and overall management of all frozen materials, including permafrost and ice-rich soils, this Water Management Plan describes best management practices for containing and controlling sediment laden runoff from areas developed in permafrost terrain.

If and when constructed, the Ice Rich Overburden Storage Area (IROSAs) would serve as a dewatering area for any future large volumes of ice-rich material that is excavated during construction and operations. The design (Appendix A in the FMMP) is based on the concept of flow-through berms that permit the exfiltration of excess

water to the subsurface while filtering out sediments suspended in the excess pore water. The design consists of five berms to create four storage cells for containing the thawing ice-rich materials. To date, only relatively small volumes of ice-rich material have been encountered and thus construction of the IROSA has not been necessary.

6.10 MAINTENANCE AND MONITORING STRATEGIES

Regular monitoring of implemented BMPs is essential to the success of the Plan. The Environmental Department regularly inspects erosion control measures including after each major runoff-producing rainfall event. Frequent and proper maintenance allows for prolonged use instead of allowing the facilities to degrade and be in need of full replacement.

Silt fences, sediment traps/basins, ditches, culverts, exfiltration areas, and water management basins/ponds are visually inspected for the following:

- excess sediment build-up;
- structural/physical integrity,
- anticipated wear and tear, and
- snow/ice build-up.

Where certain structures are found to have permafrost or saturated backslopes on the cut slopes, suitable equipment access corridors will be developed to allow for maintenance of those cut slopes.

All key water storage and conveyance structures allow for suitable access to undertake maintenance activities. Maintenance, of the LDSP, sediment basins and other water management structures is performed as required and includes:

- work required to physically stabilize structures;
- the removal ice or snow to minimize the accumulation within basins/ponds, culverts and water conveyance channels;
- the removal of sediment from ditches, SBs and the LDSP;
- the stabilization and development of adequate drainage from any saturated or permafrost cut slopes;
- the repair of any damaged liner, armouring materials or installed erosion control products; and
- the repair or replacement of any damaged or faulty monitoring or control instrumentation or equipment.

As surface conditions have begun to stabilize, the focus has been less on sediment and erosion control and more on the regular monitoring and maintenance of the stability and condition of water management structures including the main collection ditches, the LDSP and events pond, the ditching and collection of seepage from the WRSAs, the downslope monitoring of the temporary ore stockpile, and the reclamation stockpiles.

7 WATER DISTRIBUTION

Water distribution systems for the Mine include fresh water, potable water, process water, and firewater systems. Included in the process water systems are the facilities to contain, transport, and distribute mine-influenced water (MIW). The arrangement of water distribution facilities on the site is depicted in Figure 7.1-1. The figure also shows the general routing of water flows coded by color.

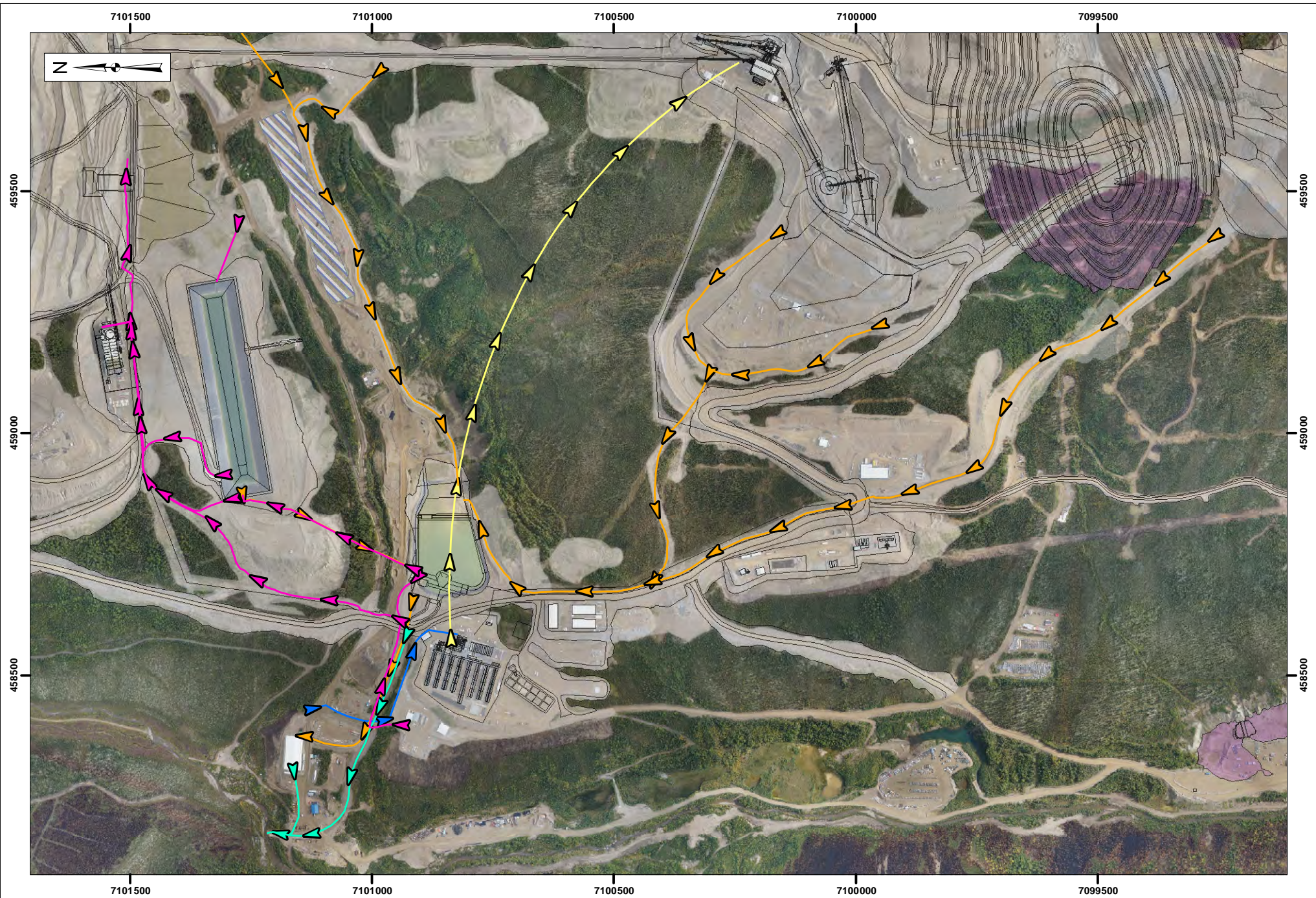

Legend:	
Contact Water	Fire Water (Trucked)
Discharge Water	Fresh Water
Makeup Water	Built
	Not Built
	Reserved Area

VICTORIA
GOLD CORP

0 75 150 300
Meters

Projection: NAD 83 UTM Zone 8	Drawn By: HC
Date: 2024/04/04	Figure: 7.1-1

**EAGLE GOLD MINE
YUKON TERRITORY**

**Mine Site Water
Distribution Plan**

7.1 FRESH WATER

The freshwater system provides water for freshwater process needs, reagent mixing, wash down water, process make-up, truck washing, fire suppression, and potable water use. Fresh/fire water infrastructure includes a fresh water booster tank and pumps at the well field, water supply pipeline, fresh/fire water tank, and freshwater distribution piping.

The principal source of freshwater is from MW10-DG7 (referred to in Section 6.8), a well constructed through the alluvial valley fill and completed in metasediments. The well is located west of the camp and the Lower Dublin South Pond. Design criteria for the freshwater system are presented in Table 7.1-1.

Table 7.1-1: Fresh Water Capacities

Factor	Criterion	Source
Peak freshwater demand	127,000 m ³ per month	KP, 2014
Fresh/Fire water tank capacity – ADR Plant	237 m ³	Installed Capacity
Fire suppression needs – Camp	125 m ³ /hr for 2 hrs	Estimate 1 standpipe
Fire water storage – Camp	250 m ³	Installed Capacity
Fire water storage – Crushing Facilities	144 m ³	Installed Capacity

7.2 PROCESS WATER

Process water requirements are primarily associated with make-up water to the Barren Solution Tank and for reagent mixing. Contact water from the LDSP has been the primary source of make-up water to the ADR/HLF, supplemented by groundwater as necessary. Make-up water demand is discussed above in Section 6.8. Water for reagent mixing will be supplied by the fresh water tank.

7.3 POTABLE

The potable water system is supplied from two wells, one constructed in 2010 and located in the Dublin Gulch alluvial valley (MW10-DG07) and one constructed in 2018 and located within the camp footprint (MW18-JDS-01). They both pass through a potable water treatment system in the camp. The water is treated to eliminate bacterial and chemical concerns and stored in a potable water tank (Figure 7.1-1). Potable water is then distributed by booster pumps and piping to the administration building, camp, change house/mine dry. Potable water is distributed by truck to the working buildings on site, including the crushing facilities and ADR building.

7.4 FIRE SUPPRESSION

Fire suppression water is provided by fire water tanks located at the ADR Plant, at the camp site, and at the crushing facilities. The ADR Plant tank is also used for the plant's fresh water and firewater needs, with storage dedicated to the plant and laboratory firewater system. It feeds to hydrant standpipes, and is equipped with jockey pumps and back up diesel jockey pump in case of power failure. The camp and administrative buildings have a dedicated firewater system, also with pump and back up diesel generator power supply in case of power failure. The crushing facility area also has a standalone firewater tank with pump and back up diesel generator jockey pump.

7.5 DUST CONTROL

During operations, most of the water for dust suppression is pumped into water trucks from the LDSP and used as per licence conditions.

Peak dust suppression demand is projected to occur in the months of June, July, and August and is estimated to be 960 m³ per day (Knight Piésold 2014). Dust control demand is variable throughout the year.

8 REFERENCES

- BGC Engineering Inc. (2012a). Eagle Gold Project - Lower Dublin Gulch Valley Aquifer Tests Project Memorandum, prepared for Victoria Gold Corp. by BGC Engineering Inc., Vancouver BC, September 2012.
- BGC Engineering Inc. (2012b). Eagle Gold Project - Open Pit Pumping Tests Project Memorandum, prepared for Victoria Gold Corp. by BGC Engineering Inc., Vancouver BC, September 2012.
- BGC Engineering Inc. (2013a). Eagle Gold Project - 2012 Groundwater Data Report, prepared for Victoria Gold Corp. by BGC Engineering Inc., Vancouver BC, July 2013.
- BGC Engineering Inc. (2013b). Eagle Gold Project - Production Well Completion Report for PW-BGC12-04, prepared for Victoria Gold Corp by BGC Engineering Inc., Vancouver BC, July 2013.
- BGC (2014). Eagle Gold Project, Numerical Hydrogeologic Model, Final Report; prepared for Victoria Gold Corp. by BGC Engineering Inc., Vancouver BC, April 2014.
- BGC (2017). Eagle Gold Project, Heap Leach Facility Detailed Design, prepared for Victoria Gold Corp. by BGC Engineering Inc., Vancouver BC, November 2017.
- BGC (2019). Eagle Gold Project, Numerical Hydrogeologic Model Update, prepared for Victoria Gold Corp. by BGC Engineering Inc., Vancouver BC, June 2019.
- BGC (2024). Eagle Gold Mine Hydrograph Update (2023 Data), prepared for Victoria Gold Corp. by BGC Engineering Inc., Vancouver BC, March 2024.
- Canadian Dam Association (CDA 2007). Dam Safety Guidelines. Toronto, Ontario Canada.
- CoreGeo/Watterson (2017). Eagle Gold Project Groundwater Quality Characterization Report prepared by Core Geoscience Services Inc., January 2017
- Forte (2023). Eagle Gold Project Heap Leach Facility 2023 Annual Water Balance Modeling Report prepared by Forte Dynamics Inc., March 30, 2023
- Golder (2022). Eagle Gold Mine Bathymetric Survey and Storage Capacity Assessment of Event Pond and Control Pond – DRAFT., prepared by Golder Associates Ltd., November 2022.
- Hogg, W.D. and Carr, D.A. (1985). Rainfall Frequency Atlas of Canada. Ministry of Environment, Canadian Climate Program. 1985.
- Knight Piésold (2013). Eagle Gold Project Hydrometeorology Report, prepared for Victoria Gold Corp. by Knight Piesold Ltd., Vancouver BC, August 2013.
- Knight Piésold (2014). Eagle Gold Project Site Water Balance Model Report, prepared for Victoria Gold Corp. by Knight Piesold Ltd., Vancouver BC, July 8 2014.
- Linkan (2014a). Engineering Design Report for the Eagle Gold Mine Water Treatment Plan, July 18, 2014.
- Linkan (2014b). Technical Memorandum: Eagle Mine Water Treatment Bench Testing, July 11, 2014.
- Linkan (2023). Operation and Maintenance Manual Victoria Gold WTP, prepared for Victoria Gold Corp. by Linkan Engineering, February 2023

- Lorax (2013). 2013 Baseline Water Quality Report: Eagle Gold Project, prepared for Victoria Gold Corp. by Lorax Environmental Services Ltd., Vancouver BC, December 2013
- Lorax (2017a), Eagle Gold Hydrometeorology Report, prepared for Victoria Gold Corp. by Lorax Environmental Services Ltd., Vancouver BC, March 13, 2017.
- Lorax (2017b), Baseline Water Quality Report (2016 Update) Eagle Gold Project prepared for Victoria Gold Corp. by Lorax Environmental Services Ltd., Vancouver BC, March 2017.
- Lorax (2022), Design Rainfall Event Analysis Memorandum, S. Jackson to H. Coyle and K. Chakhova, VGC, Sept 21, 2022.
- Lorax (2023a), Eagle Gold Project Climate Data Report 2022, prepared for Victoria Gold Corp. by Lorax Environmental Services Ltd., Vancouver BC, March 2023.
- Lorax (2023b), Eagle Gold Project Streamflow Monitoring Report - 2022 Update, prepared for Victoria Gold Corp. by Lorax Environmental Services Ltd., Vancouver BC, March 2019.
- Lorax (2023c), Eagle Gold Project 2022 Water Balance and Water Quality Model Update Report WBM v.8.0.0 by Lorax Environmental Services Ltd., Vancouver BC, March 2023.
- Lorax (2024a), Eagle Gold Project Climate Data Report 2023, prepared for Victoria Gold Corp. by Lorax Environmental Services Ltd., Vancouver BC, March 2024.
- Lorax (2024b), Eagle Gold Project Streamflow Monitoring Report - 2023 Update, prepared for Victoria Gold Corp. by Lorax Environmental Services Ltd., Vancouver BC, March 2024.
- Polster, David F. (2002). Soil Bioengineering Techniques for Riparian Restoration. Polster Environmental Services Ltd.
- Rutqvist, J. and Stephansson, O. (2003) The Role of Hydromechanical Coupling in Fractured Rock Engineering. Hydrogeology Journal, 11, pp. 7-40.
- Stantec Ltd. (2011a). Eagle Gold Project – Environmental Baseline Report: Water Quality and Aquatic Biota. June 2011.
- Stantec Ltd. (2011b). Eagle Gold Project – Environmental Baseline Report: Hydrogeology. June 2011.
- Stantec Ltd. (2012a). Eagle Gold Project – Environmental Baseline Report: Water Quality and Aquatic Biota. April 2012.
- Stantec Ltd. (2012b). Eagle Gold Project – Environmental Baseline Data Report: Hydrogeology 2011 – 2012 Update. June 2012.
- USDA (1992). Chapter 18 – Soil Bioengineering for Upland Slope Protection and Erosion Reduction. Engineering Field Handbook. United States Department of Agriculture, Natural Resources Conservation Service. October 1992

APPENDIX A

Flocculant Use Plan

1. General

This document provides a basic description of a flocculant use plan that will be implemented, if required, at the SGC Eagle Project. SGC will only use only products from the high molecular weight anionic polyacrylamides (or PAMs) group of flocculants that are non-toxic to fish to settle sediment in the Lower Dublin South Pond (LDSP), sediment control pond.

2. Identification and Testing of Appropriate Flocculant(s)

There is a wide range of anionic PAM flocculants available for water clarification however the selection of a specific product is generally informed by site specific soil and water conditions. To ensure that an appropriate product is selected for use on the Project site, a test program will be developed with the earthworks contractor and flocculant suppliers. The test program will commence upon the initial construction of the Lower Dublin South Pond (LDSP) sediment control pond. The testing program will be used to determine the optimal flocculent to meet the discharge criteria for Total Suspended Solids (TSS) (i.e., maximum monthly mean of 15.00 mg/l, and a maximum grab sample of 30.00 mg/L). The test program will specifically be conducted to determine:

- a. The identification of suitable PAM flocculant products that meet the ANSI/NSF Standard 60 for drinking water treatment and is linear (non-cross-linked or resistant to forming complex polymer chains or bonding between adjacent short polymer chains);
- b. An identified maximum dosage for the identified product;
- c. Toxicity testing results for a proposed maximum dosage of the identified PAM product;
- d. A protocol for determining the appropriate dosage rate, which may often be less than the maximum dosage, for the identified product. The protocol will be based on monitoring data (i.e., flow rate, TSS, turbidity) collected routinely and periodically (i.e., likely several times a day during initial establishment to daily once established) from incoming streams (i.e., Ditches A and B).
- e. The Scope of the Testing Program in development is described in Section 2.1

Once the test program is completed, and a suitable PAM flocculant(s) has been determined, a design will be prepared for dosing the flocculant(s) into the feed water going into the LDSP. Material Safety Data Sheets (MSDSs) will be submitted with the design once the PAM products have been identified and tested for performance. Appendix A provides the MSDS for a range of anionic PAM products that may be used to reduce sediment loads in contact water on the Project site.

2.1 Scope of Required Testing for Flocculant Determination

Initial testing will be conducted by a selected Flocculant vendor, or third party testing service. The testing will be a standard Laboratory Jar test. The following guidelines will be followed

- Test a minimum of 3 separate polymers covering the tester's recommended polymer formulations for the raw water. The candidate polymers should include as many permutations as practical for the following general polymer characteristics.
- A minimum of five different levels of turbidity will be conducted with equal spacing between the minimum allowable level of 15 mg/l and 1000 mg/l.
- The Jar tests will be conducted for each product at different dosages with the tests run side-by-side, and the results compared to an untreated jar. A minimum of 10 different doses will be conducted for each products.

3. Operational Plan for Flocculant System

Should flocculants be required on site to manage elevated TSS concentrations in the discharge from the LDSP or sediment basins, a flocculation system as shown in Figure 1 (assuming the LDSP) will be used. This concept is summarized as follows:

- A centralized flocculation station will prepare a polymer solution from dry polymer powder for in-line injection into Ditch A and Ditch B feeding the LDSP. The maximum batching capacity is expected to be determined during testing;
- The flocculation station and batching and storage tanks will have secondary containment for the expected working volumes of stored liquid;
- It is anticipated that the flocculant storage, station, batching and storage tanks will be assembled into a 40' x8' Sea container converted into mix plant for this application. The plant (if required) will be stationed to the East of the LDSP, before the fore bay;
- Turbidity testing will be conducted daily at regular intervals to determine flocculant addition dosage requirements when there is water to be discharged from the LDSP. Water will be tested at the discharge well of the LDSP, to determine turbidity of the water at the point where it will be released, at the edge of the still well/pump house location of the pond, in the entrance to the main pond, and in the forebay, so that differences in turbidity can be monitored from the entrance to the exit of the water holding area;
- Make-up water for the polymer is expected to be drawn from the secondary portion of the LSDP or from a sediment basin, because the inflow will under most conditions be ephemeral and relatively low. Alternatively, make-up water will be drawn from either a water tank or a nearby water course;
- Protocols for determining the appropriate dosing rates will be prepared from the original testing based on the chosen product. The protocols will be reviewed once in operation to determine the effectiveness and make adjustments to dosing
- The flocculation system will be complete with metering and controls for the mixing and pumping to injection locations; and
- The dry polymer will be shipped to site in 1.0 m³ super sacks and will be stored indoors.

A standard operating procedure will be developed for the efficient, effective, and controlled addition of the flocculant. The procedure will include, at a minimum, the following:

- Monitoring Requirements (frequency and locations for TSS, turbidity and flow rate);
- Monitoring Methods (sampling and analyses);
- Polymer Handling, Storage and Maintenance;
- Batch Plant Operations and Maintenance (includes make-up water system);
- Periodic Performance Testing to ensure appropriate dosing and uses of identified flocculants; and
- Reporting Protocols and Requirements (for each of the above procedures).

Figure 1 Block Flow Diagram of Flocculation Concept

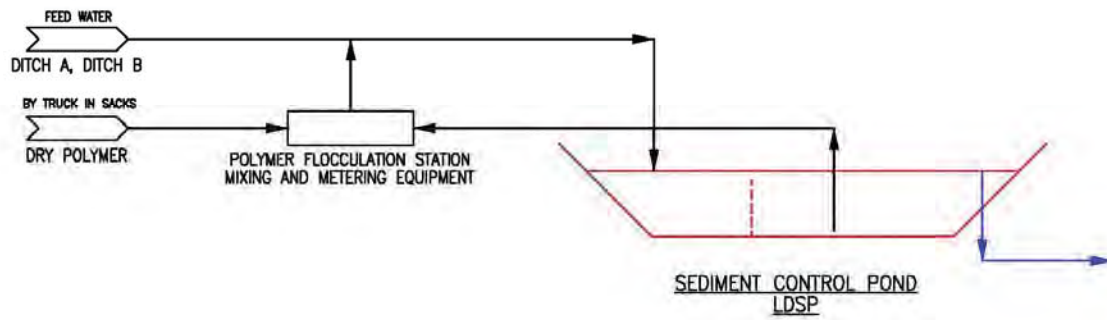

END OF SECTION



MATERIAL SAFETY DATA SHEET

PAM A Series

Section 01 - Product And Company Information

Product Identifier PAM A-03, PAM A-103, PAM A-303, PAM A-403, PAM A-503, PAM A-502, PAM A-702, PAM A-703, PAM A-903, PAM A-1003, PAM A-1002, PAM A-1503, PAM A-1803, PAM A-2003

Product Use Anionic water treatment polymer.

Supplier Name ClearTech Industries Inc.
1500 Quebec Avenue
Saskatoon, SK. Canada
S7K 1V7

Prepared By ClearTech Industries Inc. Technical Department
Phone: (306)664-2522

24-Hour Emergency Phone 306-664-2522

Section 02 - Composition / Information on Ingredients

Hazardous Ingredients Contains no hazardous ingredients

CAS Number Not applicable

Synonym (s) Not available

Section 03 - Hazard Identification

Inhalation Not available

Skin Contact / Absorption Irritating to skin

Eye Contact Irritating to eyes

Ingestion Not available



Exposure Limits..... Nuisance dust: 15mg/m³

Section 04 - First Aid Measures

Inhalation..... Remove victim to fresh air. Give artificial respiration only if breathing has stopped. If breathing is difficult, give oxygen. Seek immediate medical attention.

Skin Contact / Absorption..... Remove contaminated clothing. Wash affected area with soap and water. Seek medical attention if irritation occurs or persists

Eye Contact..... Flush immediately with water for at least 20 minutes. Forcibly hold eyelids apart to ensure complete irrigation of eye tissue. Seek immediate medical attention

Ingestion..... Do not induce vomiting. Consult a physician.

Additional Information..... Not available

Section 05 - Fire Fighting Measures

Conditions of Flammability..... Not available

Means of Extinction..... Foam, carbon dioxide, dry powder

Flash Point..... Not available

Auto-ignition Temperature..... Not available

Upper Flammable Limit Not available

Lower Flammable Limit..... Not available

Hazardous Combustible Products... Nitrogen oxides, carbon monoxide and carbon dioxide.

Special Fire Fighting Procedures..... Wear NIOSH-approved self-contained breathing apparatus and protective clothing. When this product comes in contact with water, surfaces become very slippery.



Explosion Hazards..... Not available

Section 06 - Accidental Release Measures

Leak / Spill..... Wear appropriate personal protective equipment. Ventilate area. Stop or reduce leak if safe to do so. Prevent material from entering sewers. Do not flush with water. Clean up promptly by sweeping or vacuum. After cleaning, flush away traces with water.

Deactivating Materials..... Not available

Section 07 - Handling and Storage

Handling Procedures..... Use proper equipment for lifting and transporting all containers. Use sensible industrial hygiene and housekeeping practices. For good industrial hygiene, avoid contact with skin and eyes, avoid forming dust, and wash hands before breaks and at the end of the workday. Avoid all situations that could lead to harmful exposure.

Storage Requirements..... Keep in a dry, cool place with the container well sealed.

Section 08 - Personal Protection and Exposure Controls

Protective Equipment

Eyes..... Chemical goggles, full-face shield, or a full-face respirator is to be worn at all times when product is handled. Contact lenses should not be worn; they may contribute to severe eye injury.

Respiratory..... Use dust masks where dust exceeds 15mg/m³

Gloves..... Impervious gloves of chemically resistant material (rubber or PVC) should be worn at all times. Wash contaminated clothing and dry thoroughly before reuse.

Clothing..... Body suits, aprons, and/or coveralls of chemical resistant material should be worn at all times. Wash contaminated clothing and dry thoroughly before reuse.

Footwear..... No special footwear is required other than what is mandated at place of work.



Engineering Controls

- Ventilation Requirements**..... Mechanical ventilation (dilution or local exhaust), process or personnel enclosure and control of process conditions must be provided in accordance with all fire codes and regulatory requirements. Supply sufficient replacement air to make up for air removed by exhaust systems.
- Other**..... Emergency shower and eyewash must be available and tested in accordance with regulations and be in close proximity.

Section 09 - Physical and Chemical Properties

- Physical State**..... Granular solid
- Odor and Appearance**..... Virtually no odor, off white
- Odor Threshold**..... Not available
- Specific Gravity (Water=1)**..... Not available
- Vapor Pressure (mm Hg, 20C)**..... Not available
- Vapor Density (Air=1)**..... Not available
- Evaporation Rate**..... Not available
- Boiling Point**..... Not available
- Freeze/Melting Point**..... Not available
- pH**..... 4-6 @ 5g/L
- Water/Oil Distribution Coefficient**.... Not available
- Bulk Density**..... Not available
- % Volatiles by Volume**..... Not available
- Solubility in Water**..... Complete
- Molecular Formula**..... Not available
- Molecular Weight**..... Not available

Section 10 - Stability and Reactivity



- Stability**..... Product is stable
- Incompatibility**..... Oxidizing agents, galvanized metals, mild steel, copper and brass.
- Hazardous Products of Decomposition**.. Thermal decomposition may produce nitrogen oxides.
- Polymerization**..... Will not occur

Section 11 - Toxicological Information

- Irritancy**..... Draize tests showed material produces no corneal or iridial effects only slight transitory conjunctival effects similar to those which all granular materials have on conjunctivae.
- Sensitization**..... Testing on guinea pigs showed this material to be non-sensitizing.
- Chronic/Acute Effects**..... A two-year feeding study on rats did not reveal adverse health effects.
- Synergistic Materials**..... Not available
- Animal Toxicity Data**..... LD₅₀(oral, rat)= >5000mg/kg
- Carcinogenicity**..... Not considered to be carcinogenic by NTP, IARC, and OSHA.
- Reproductive Toxicity**..... Not available
- Teratogenicity**..... Not available
- Mutagenicity**..... Not available

Section 12 - Ecological Information

- Fish Toxicity**..... LC₅₀(96 hrs, Fathead minnows)= >1000mg/L
- Biodegradability**..... Not readily biodegradable, this product is not expected to bioaccumulate.
- Environmental Effects**..... The product is not considered toxic to aquatic organisms or harmful to the aquatic environment.

Section 13 - Disposal Consideration



Waste Disposal..... Dispose in accordance with all federal, provincial, and/or local regulations including the Canadian Environmental Protection Act.

Section 14 - Transportation Information

TDG Classification

Class..... Not regulated

Group..... Not regulated

PIN Number..... Not regulated

Other..... Secure containers (full and/or empty) with suitable hold down devices during shipment and ensure all caps, valves, or closures are secured in the closed position.

Section 15 - Regulatory Information

WHMIS Classification.....Not a controlled product

NOTE: THE PRODUCT LISTED ON THIS MSDS HAS BEEN CLASSIFIED IN ACCORDANCE WITH THE HAZARD CRITERIA OF THE CANADIAN CONTROLLED PRODUCTS REGULATIONS. THIS MSDS CONTAINS ALL INFORMATION REQUIRED BY THOSE REGULATIONS.

NSF Certification.....PAM A-503 is certified under ANSI/NSF Standard 60 for coagulation and flocculation at a maximum dosage of 1mg/L.

Section 16 - Other Information

Note: The responsibility to provide a safe workplace remains with the user. The user should consider the health hazards and safety information contained herein as a guide and should take those precautions required in an individual operation to instruct employees and develop work practice procedures for a safe work environment. The information contained herein is, to the best of our knowledge and belief, accurate. However, since the conditions of handling and use are beyond our control, we make no guarantee of results, and assume no liability for damages incurred by the use of this material. It is the responsibility of the user to comply with all applicable laws and regulations.

Attention: Receiver of the chemical goods / MSDS coordinator

As part of our commitment to the Canadian Association of Chemical Distributors (CACD) Responsible Distribution® initiative, ClearTech Industries Inc. and its associated companies require, as a condition of sale, that you forward the attached Material Safety Data Sheet(s) to all affected employees, customers, and end-users. ClearTech will send any available supplementary handling, health, and safety information to you at your request.

If you have any questions or concerns please call our customer service or technical service department.



Preparation Date.....January 21, 2015

ClearTech Industries Inc. - Locations

Corporate Head Office: 1500 Quebec Avenue, Saskatoon, SK, S7K 1V7

Phone: 800-387-7503

Fax: 888-281-8109

www.ClearTech.ca

Location	Address	Postal Code	Phone Number	Fax Number
Richmond, B.C.	12431 Horseshoe Way	V7A 4X6	800-387-7503	888-281-8109
Port Coquitlam	2023 Kingsway Avenue	V3C 1S9	800-387-7503	888-281-8109
Calgary, AB.	5516E - 40 th St. S.E.	T2C 2A1	800-387-7503	888-281-8109
Edmonton, AB.	12020 - 142 nd Street	T5L 2G8	800-387-7503	888-281-8109
Saskatoon, SK.	North Corman Industrial Park	S7K 1V7	800-387-7503	888-281-8109
Regina, SK.	555 Henderson Drive	S42 5X2	800-387-7503	888-281-8109
Winnipeg, MB.	340 Saulteaux Crescent	R3J 3T2	800-387-7503	888-281-8109
Mississauga, ON.	355 Admiral Blvd Unit #1	L5T 2N1	800-387-7503	888-281-8109

24 Hour Emergency Number - All Locations – 1(306) 664-2522
Alternative - 1(800) 387-7503

APPENDIX B

As-Built Record Drawings and Reports

WATER MANAGEMENT PLAN NELPCo EAGLE GOLD MINE, YT



SITE LOCATION
SCALE: NTS

RECORD DRAWING

\\local\hball\legacy\Vancover\Drafting\Transportation\WTRM\WTRM03037-01\WTRM03037-01 - Eagle Gold Design_R3 RECORD.dwg [G1.00] January 29, 2018 - 1:29:23 pm (BY: MANG, JUSTIN)

CLIENT 		PROJECT NO.	OFFICE	DES	CKD	REV	DRAWING
		WTRM03037-01	VANC	DH	MH	3	
DATE	SHEET No.	DWN	APP	STATUS			
January 29, 2018	of	JDM	MH	REC			

\\lcalahel\legacy\Vancover\Drafting\Transportation\WTRM\WTRM03037-01\WTRM03037-01 - Eagle Gold Design_R3 RECORD.dwg [G1.01] January 29, 2018 - 4:02:25 pm (BY: MANG, JUSTIN)

INDEX OF DRAWINGS	
DWG No.	DESCRIPTION
G1.00	COVER SHEET
G1.01	DRAWING INDEX AND GENERAL NOTES
G1.04	BOREHOLE AND TEST PIT LOCATION PLAN
C1.01	LOWER DUBLIN SOUTH POND - PLAN
C1.02	LOWER DUBLIN SOUTH POND - PROFILES
C1.03	LOWER DUBLIN SOUTH POND - TYPICAL SECTIONS
C1.04	LOWER DUBLIN SOUTH POND - SPILLWAY PLAN AND PROFILE
C1.05	LOWER DUBLIN SOUTH POND - SECTIONS AND DETAILS
C1.06	LOWER DUBLIN SOUTH POND - LOW LEVEL OUTLET AND PUMPHOUSE

DESIGN CRITERIA:

- DAM CLASSIFICATION: SIGNIFICANT
- LOWER DUBLIN SOUTH POND CAPACITY (MINIMUM 24 HOUR RETENTION TIME): 1 IN 10 YEAR FLOOD.
- MAIN DAM SPILLWAY: 1 IN 1000 YEAR FLOOD
- COLLECTION DITCHES: 1 IN 10 YEAR FLOOD FOR CAPACITY, 1 IN 100 YEAR FLOOD FOR EROSION
- CULVERT DOWNSTREAM OF THE DAM (H w/D=1.5): 1 IN 1000 YEAR FLOOD
- REST OF CULVERTS (H w/D-1.5): 1 IN 200 YEAR FLOOD

HYDROLOGY:

- RECENT PRECIPITATION DATA HAS BEEN REVIEWED AS PART OF THE DESIGN AND FOUND TO BE WITHIN THE NATURAL VARIABILITY.

DISCLAIMER

- These record drawings have been compiled from as-built information provided to Tetra Tech by JDS Energy & Mining Inc. Tetra Tech assumes no responsibility for the accuracy of this information.

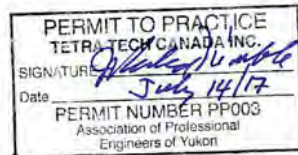

RECORD DRAWING

NUM	DATE	DWN	CKD	APR	DESCRIPTION
3	1/29/18	JDM	DH	MH	RECORD DRAWING
2	10/20/17	JDM	DH	MH	DESIGN CHANGE 002
1	7/14/17	JDM	DH	MH	ISSUED FOR CONSTRUCTION
0	7/6/17	JDM	DH	MH	ISSUED FOR CONSTRUCTABILITY REVIEW



CLIENT

WATER MANAGEMENT PLAN NELPCo EAGLE GOLD MINE , YT					
DRAWING INDEX AND GENERAL NOTES					
PROJECT NO.	OFFICE	DES	CKD	REV	DRAWING
WTRM03037-01	VANC	DH	MH	3	G1.01
DATE	SHEET No. of	DWN	APP	STATUS	
January 29, 2018		JDM	MH	REC	

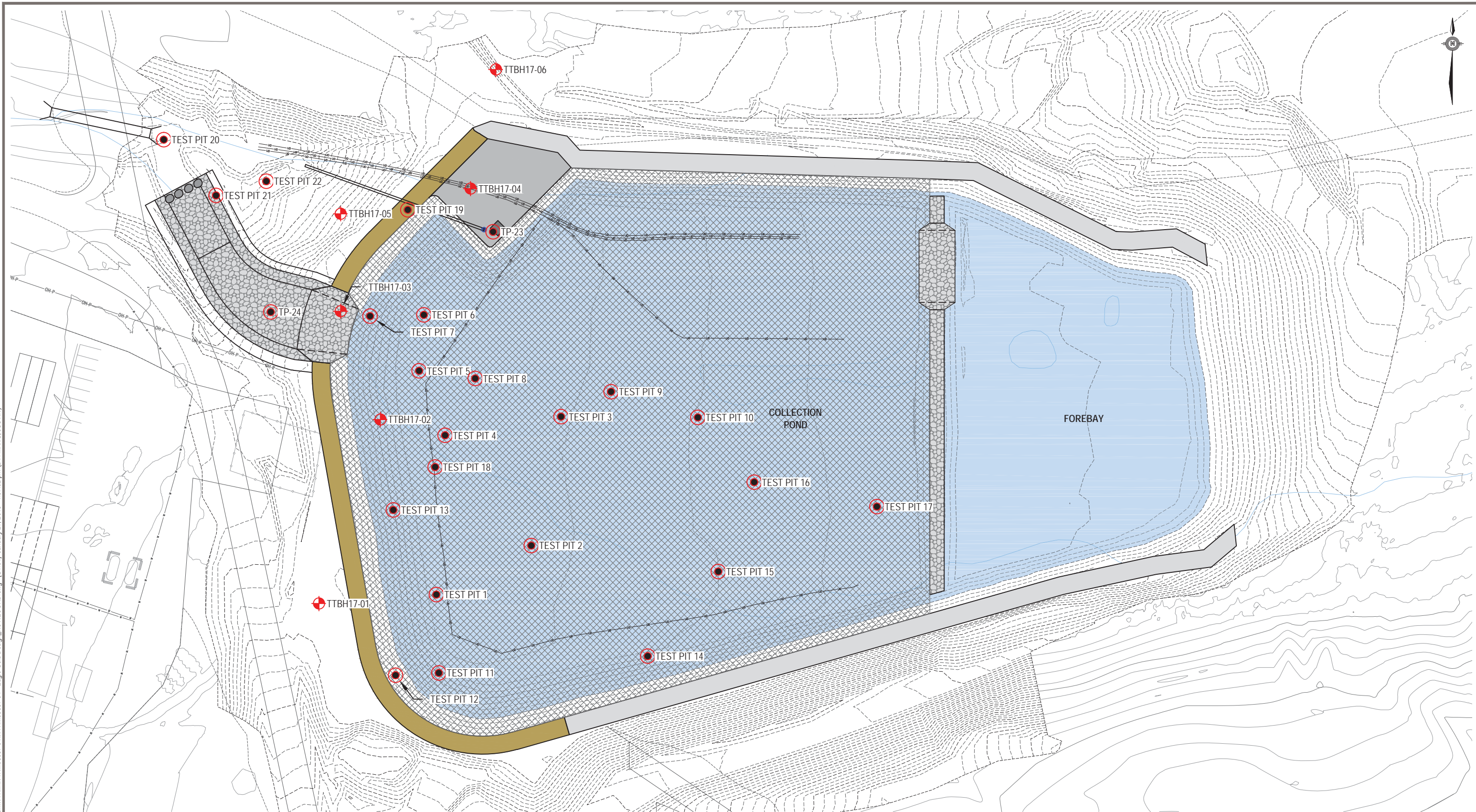

W:\local\hella\Legacy\Drawings\Drafting\Transportation\WTRM\WTRM03037-01\WTRM03037-01 - Eagle Gold Design_R3 RECORD.dwg [G1.04] January 29, 2018 - 1:37:02 pm (BY: MANG, JUSTIN)

- LEGEND**
- Design Major Contours (2 m)
 - Design Minor Contours (0.5 m)

NOTES

PERMIT TO PRACTICE
 TETRA TECH CANADA INC.
 SIGNATURE: *[Signature]*
 Date: *July 14/17*
 PERMIT NUMBER PPO03
 Association of Professional Engineers of Yukon

RECORD DRAWING

NUM	DATE	DWN	CKD	APR	DESCRIPTION
2	1/29/18	JDM	DH	MH	RECORD DRAWING
1	10/10/17	JDM	DH	MH	ADDED TEST PIT LOCATIONS
0	7/14/17	JDM	DH	MH	ISSUED FOR CONSTRUCTION



WATER MANAGEMENT PLAN NELPCo EAGLE GOLD MINE, YT					
BOREHOLE AND TEST PIT LOCATION PLAN					
PROJECT NO. WTRM03037-01	OFFICE VANC	DES DH	CKD MH	REV 2	DRAWING G1.04
DATE January 29, 2018	SHEET No. of	DWN JDM	APP MH	STATUS REC	

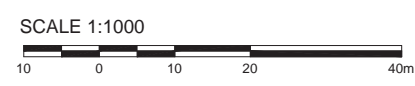

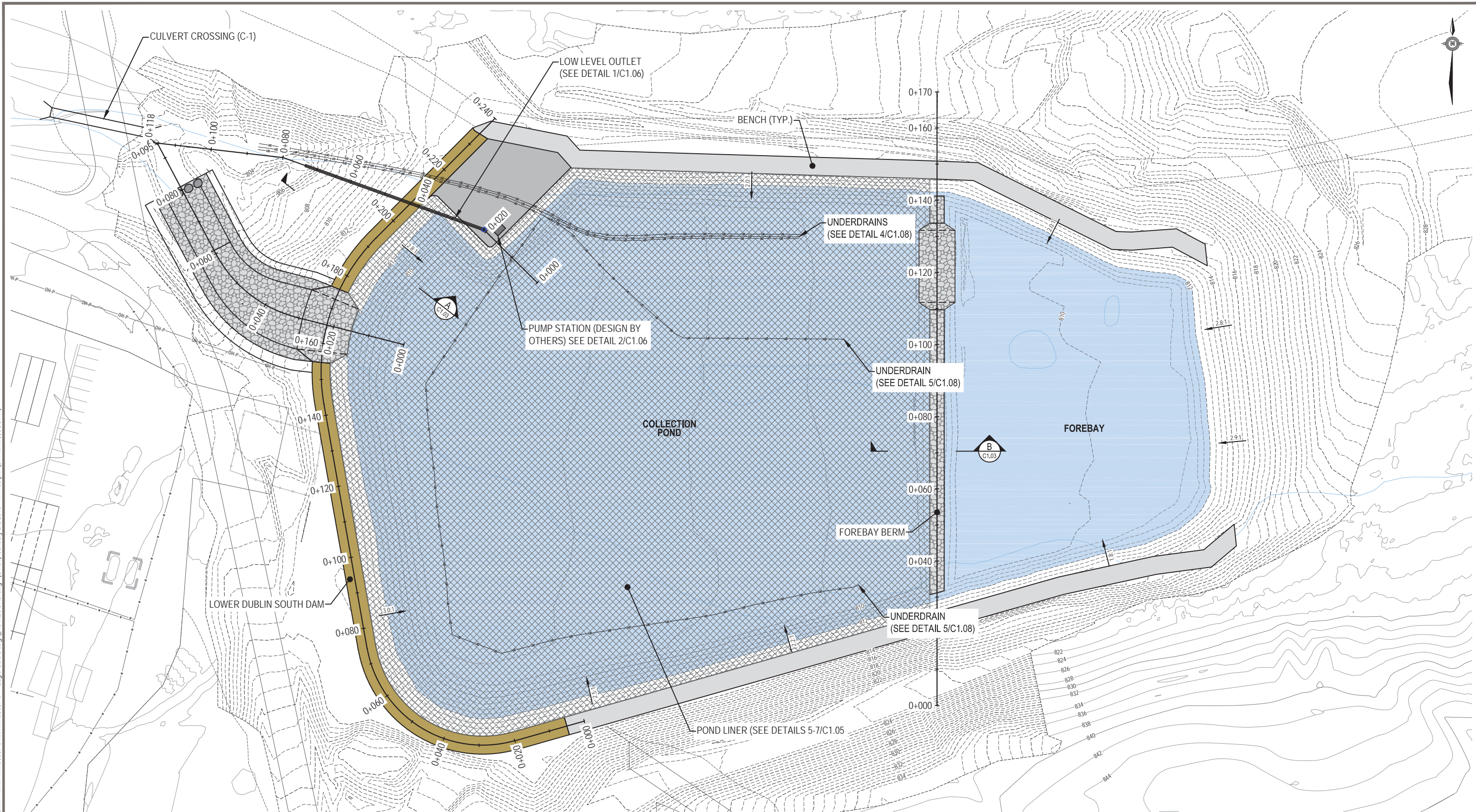

W:\local\h\legacy\Vancover\Drafting\Transportation\WTRM\WTRM03037-01 - Eagle Gold Design - R3 RECORD.dwg [C1.01] January 29, 2018 - 1:41:05 pm (BY: MANG, JUSTIN)

- LEGEND**
- Design Major Contours (2 m)
 - Design Minor Contours (0.5 m)

NOTES

PERMIT TO PRACTICE
 TETRA TECH CANADA INC.
 SIGNATURE: *[Signature]*
 Date: *July 14/17*
 PERMIT NUMBER PPO03
 Association of Professional Engineers of Yukon

RECORD DRAWING

NUM	DATE	DWN	CKD	APR	DESCRIPTION
4	1/29/18	JDM	DH	MH	RECORD DRAWING
3	10/20/17	JDM	DH	MH	DESIGN CHANGE 002
2	9/29/17	JDM	DH	MH	DESIGN CHANGE 001
1	7/14/17	JDM	DH	MH	ISSUED FOR CONSTRUCTION
0	7/6/17	JDM	DH	MH	ISSUED FOR CONSTRUCTABILITY REVIEW

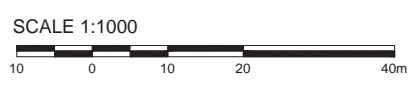

CLIENT

WATER MANAGEMENT PLAN					
NELPCo EAGLE GOLD MINE, YT					
LOWER DUBLIN SOUTH POND PLAN					
PROJECT NO. WTRM03037-01	OFFICE VANC	DES DH	CKD MH	REV 4	DRAWING C1.01
DATE January 29, 2018	SHEET No. of	DWN JDM	APP MH	STATUS REC	

\\lcal\hcal\legacy\Vancover\Drafting\Transportation\WTRM\WTRM03037-01 - Eagle Gold Design_R3 RECORD.dwg [C1.02] January 29, 2018 - 1:49:12 pm (BY: MANG, JUSTIN)

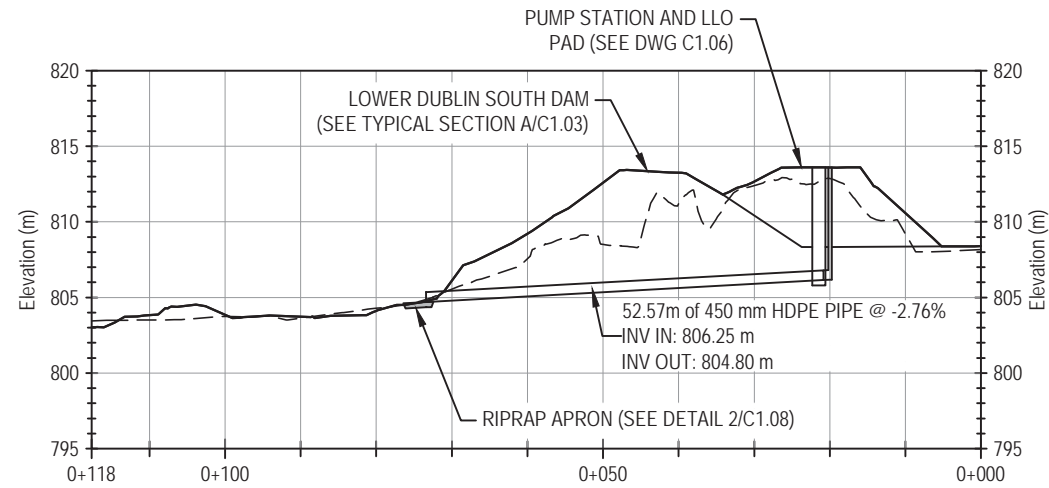

1 LOW LEVEL OUTLET PROFILE
C1.02 SCALE: 1:1000 (HORIZ.) 1:500 (VERT)

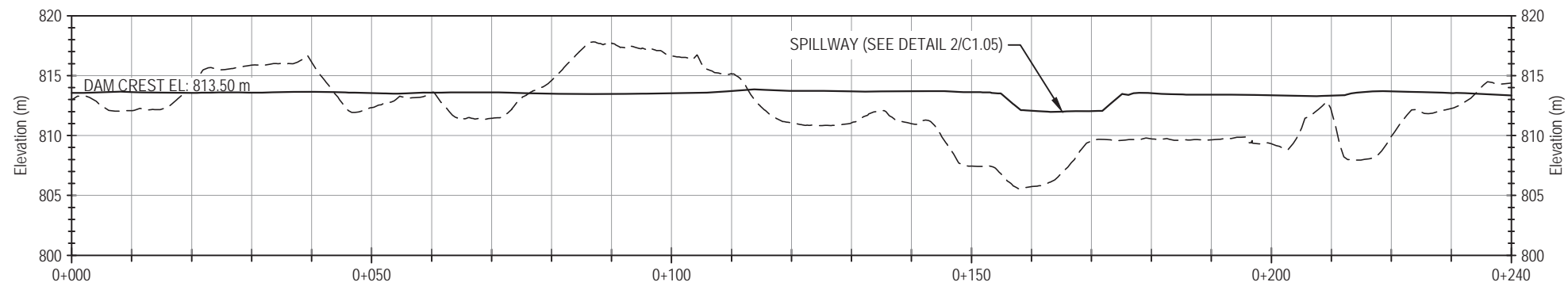

2 DAM CENTERLINE PROFILE
C1.02 SCALE: 1:1000 (HORIZ.) 1:500 (VERT)

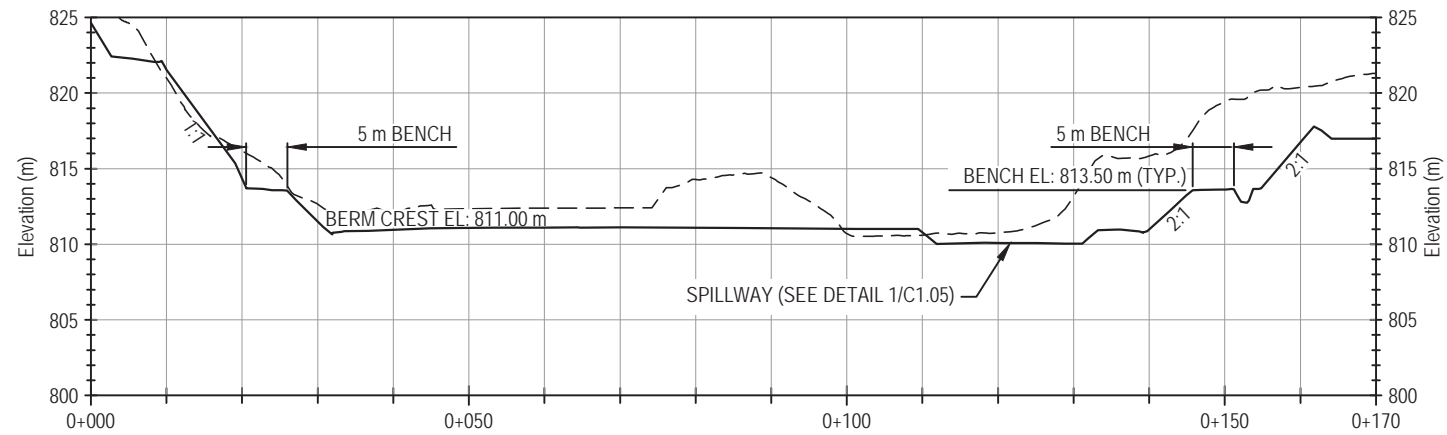

3 BERM CENTERLINE PROFILE
C1.02 SCALE: 1:1000 (HORIZ.) 1:500 (VERT)

NOTE:

1. PROFILE VIEWS ARE EXAGGERATED BY TWO TIMES VERTICALLY.

LEGEND

- Existing Ground
- Proposed Ground

NOTES

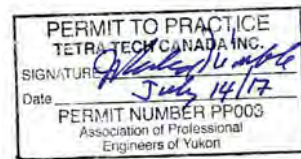

RECORD DRAWING

NUM	DATE	DWN	CKD	APR	DESCRIPTION
4	1/29/18	JDM	DH	MH	RECORD DRAWING
3	10/20/17	JDM	DH	MH	DESIGN CHANGE 002
2	9/29/17	JDM	DH	MH	DESIGN CHANGE 001
1	7/14/17	JDM	DH	MH	ISSUED FOR CONSTRUCTION
0	7/6/17	JDM	DH	MH	ISSUED FOR CONSTRUCTABILITY REVIEW



CLIENT



**WATER MANAGEMENT PLAN
NELPCo EAGLE GOLD MINE, YT**

**LOWER DUBLIN SOUTH POND
PROFILES**

PROJECT NO. WTRM03037-01	OFFICE VANC	DES DH	CKD MH	REV 4	DRAWING C1.02
DATE January 29, 2018	SHEET No. of	DWN JDM	APP MH	STATUS REC	

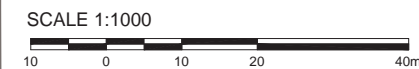

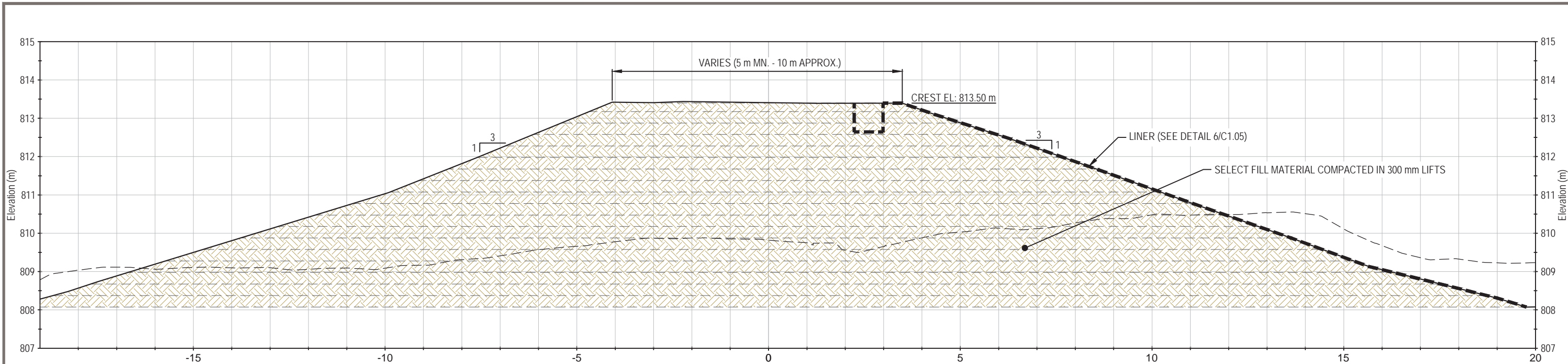

A TYPICAL DAM SECTION
C1.03 SCALE: 1:100

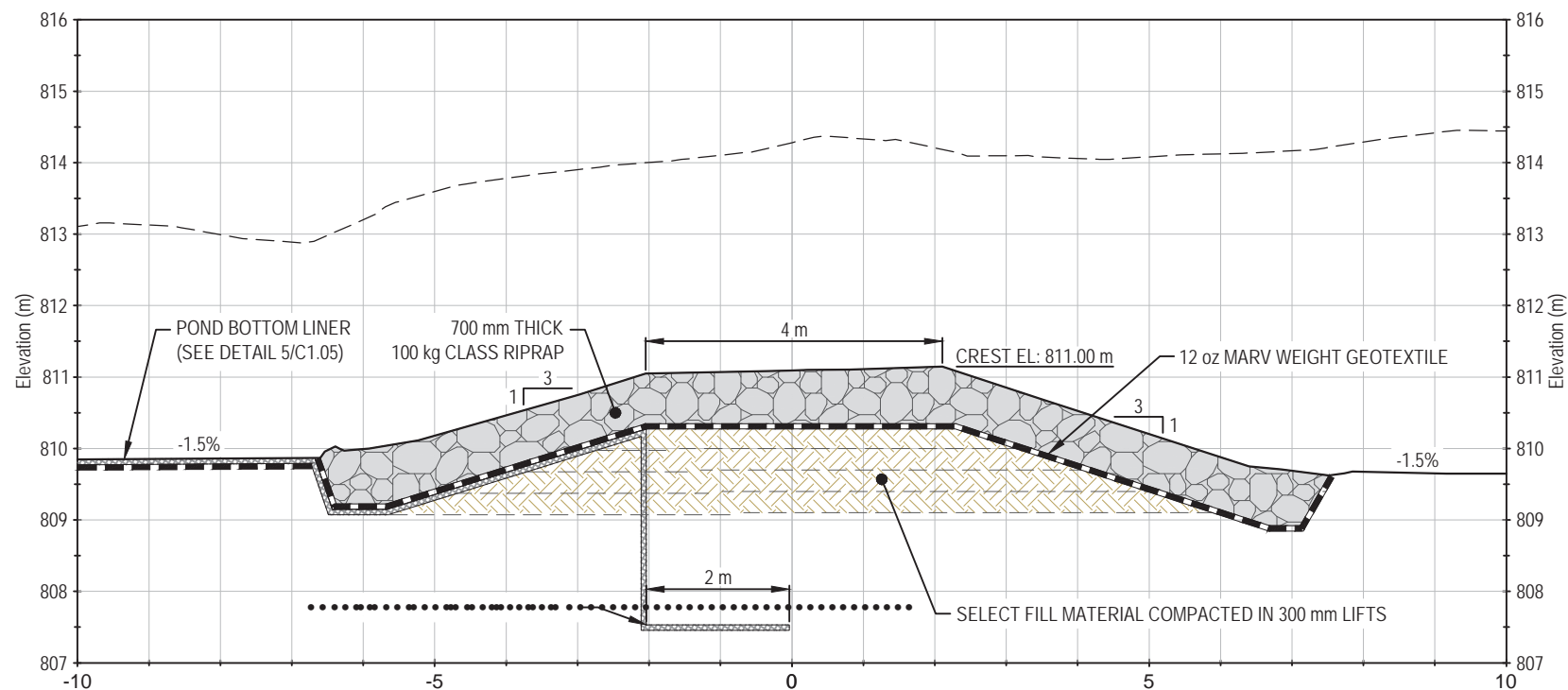

B TYPICAL FOREBAY EMBANKMENT SECTION
C1.03 SCALE: 1:100

LEGEND
 - - - Existing Ground
 — Proposed Ground

NOTES

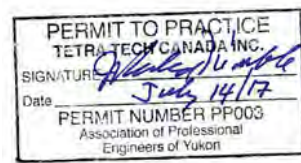

RECORD DRAWING

NUM	DATE	DWN	CKD	APR	DESCRIPTION
4	1/29/18	JDM	DH	MH	RECORD DRAWING
3	10/20/17	JDM	DH	MH	DESIGN CHANGE 002
2	9/29/17	JDM	DH	MH	DESIGN CHANGE 001
1	7/14/17	JDM	DH	MH	ISSUED FOR CONSTRUCTION
0	7/6/17	JDM	DH	MH	ISSUED FOR CONSTRUCTABILITY REVIEW



WATER MANAGEMENT PLAN NELPCo EAGLE GOLD MINE, YT					
LOWER DUBLIN SOUTH POND TYPICAL SECTIONS					
PROJECT NO. WTRM03037-01	OFFICE VANC	DES DH	CKD MH	REV 4	DRAWING C1.03
DATE January 29, 2018	SHEET No. of	DWN JDM	APP MH	STATUS REC	

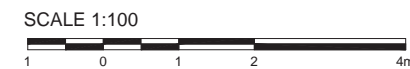

W:\local\hella\Legacy\Vancover\Drafting\Transportation\WTRM03037-01 - Eagle Gold Design_R3 RECORD.dwg [C1.03] January 29, 2018 - 3:46:46 pm (BY: MANG, JUSTIN)

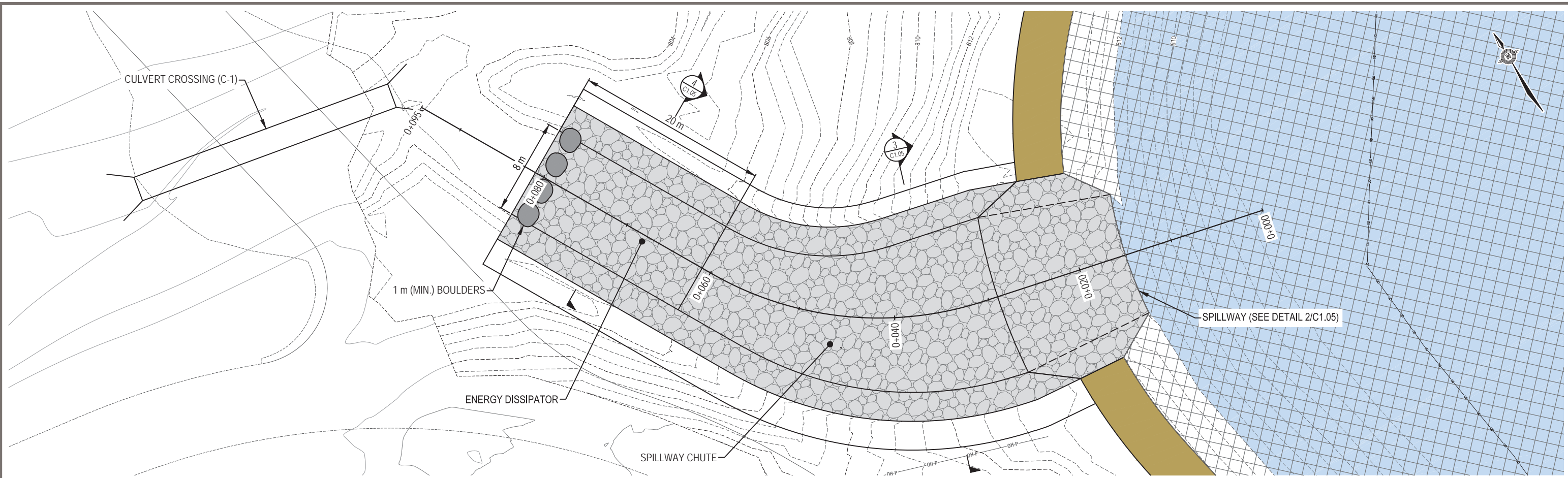

PLAN
SCALE: 1:400

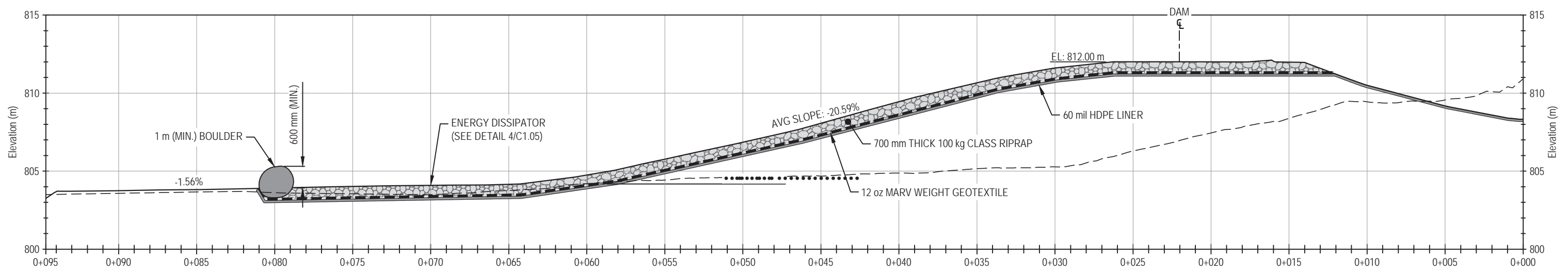

1 SPILLWAY PROFILE
SCALE: 1:250

LEGEND

---	Existing Ground
—	Proposed Ground

NOTES

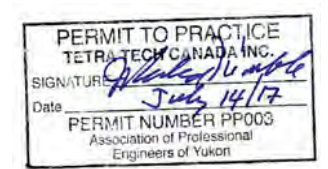

ISSUED FOR CONSTRUCTION

NUM	DATE	DWN	CKD	APR	DESCRIPTION
4	1/29/18	JDM	DH	MH	RECORD DRAWING
3	10/20/17	JDM	DH	MH	DESIGN CHANGE 002
2	9/29/17	JDM	DH	MH	DESIGN CHANGE 001
1	7/14/17	JDM	DH	MH	ISSUED FOR CONSTRUCTION
0	7/6/17	JDM	DH	MH	ISSUED FOR CONSTRUCTABILITY REVIEW



CLIENT

WATER MANAGEMENT PLAN
NELPCo EAGLE GOLD MINE, YT

LOWER DUBLIN SOUTH POND
SPILLWAY PLAN AND PROFILE

PROJECT NO. WTRM03037-01	OFFICE VANC	DES DH	CKD MH	REV 4	DRAWING C1.04
DATE January 29, 2018	SHEET No. of	DWN JDM	APP MH	STATUS REC	

SCALE AS SHOWN

W:\local\hella\Legacy\Vancover\Drafting\Transportation\WTRM\WTRM03037-01\WTRM03037-01 - Eagle Gold Design_R3 RECORD.dwg [C1.04] January 29, 2018 - 1:50:48 pm (BY: MANG, JUSTIN)

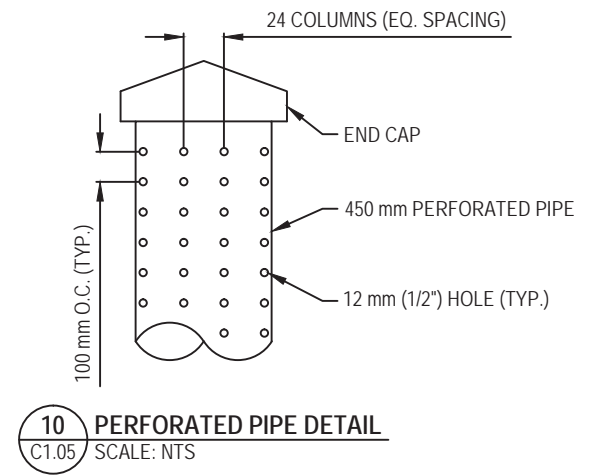
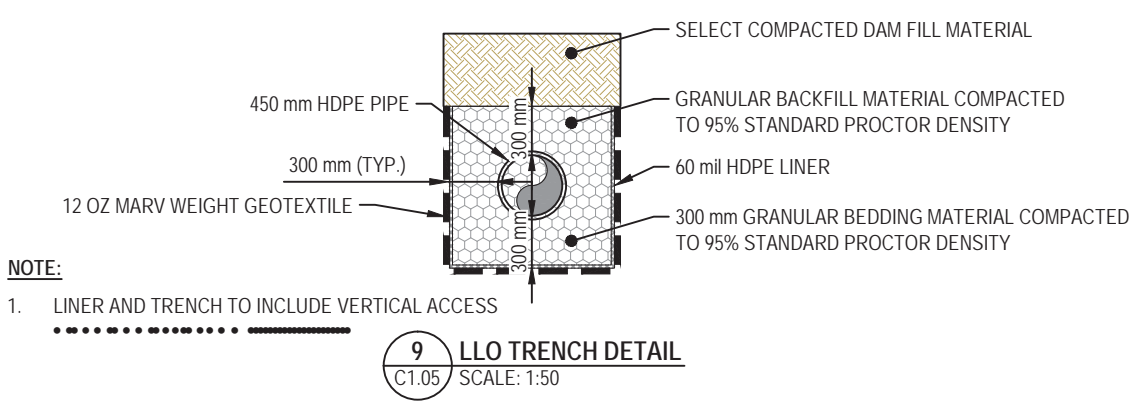
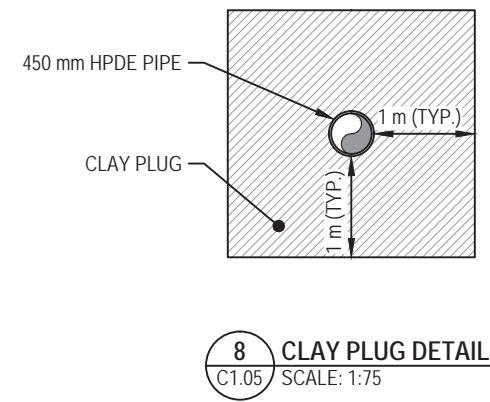
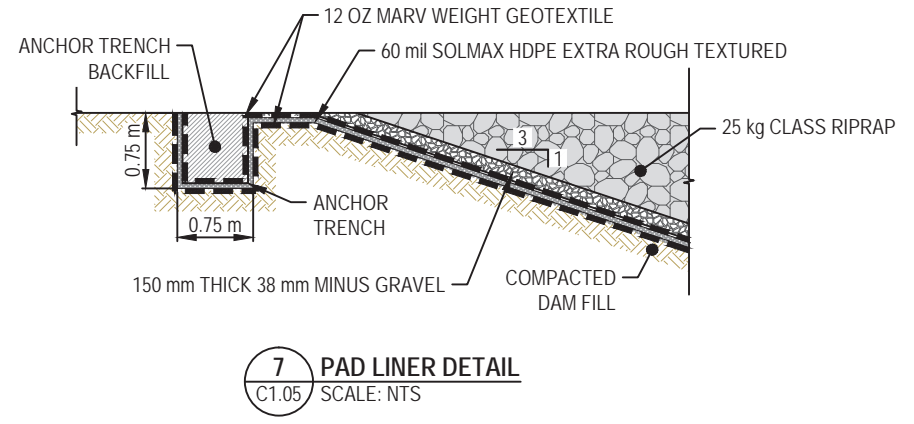
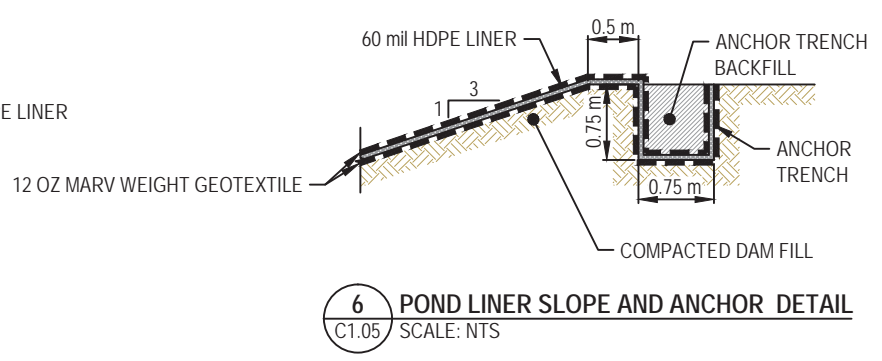
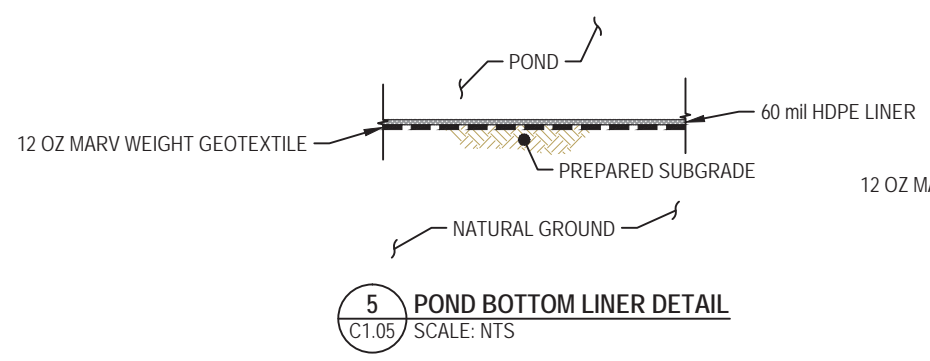
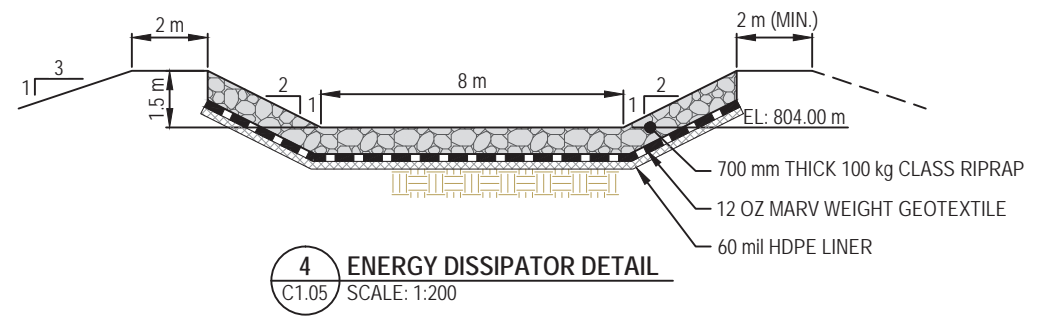
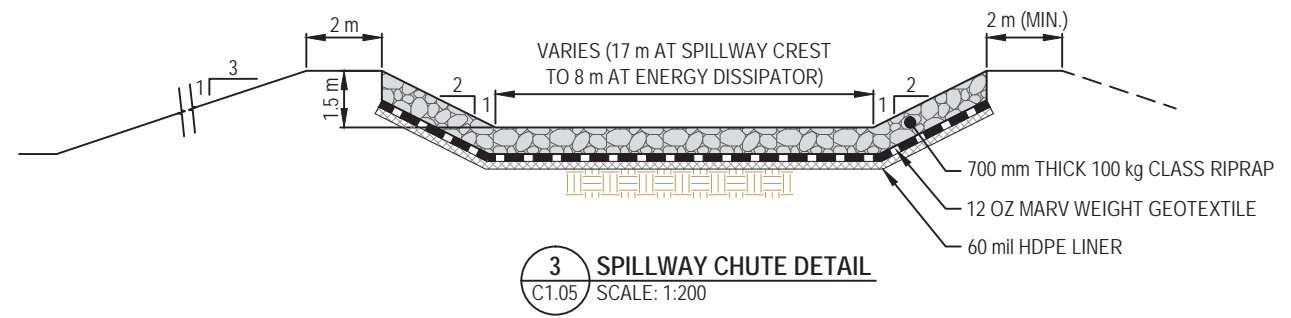
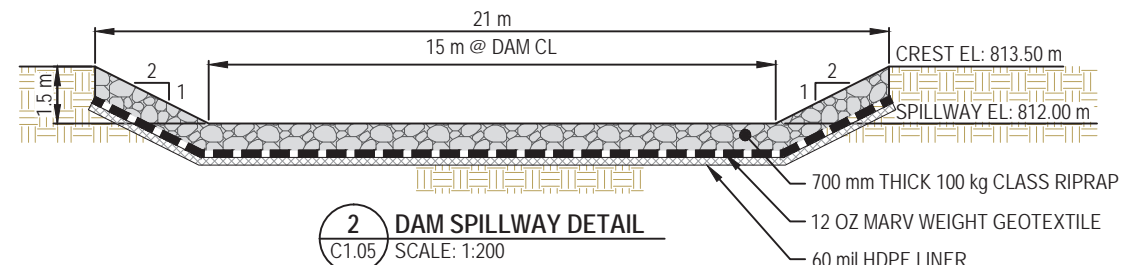
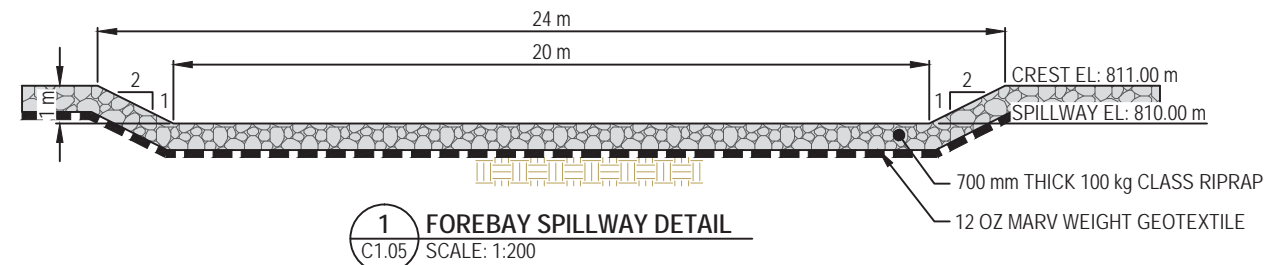

NOTE:
1. LINER AND TRENCH TO INCLUDE VERTICAL ACCESS

LEGEND

NOTES



RECORD DRAWING

NUM	DATE	DWN	CKD	APR	DESCRIPTION
4	1/29/18	JDM	DH	MH	RECORD DRAWING
3	10/20/17	JDM	DH	MH	DESIGN CHANGE 002
2	9/29/17	JDM	DH	MH	DESIGN CHANGE 001
1	7/14/17	JDM	DH	MH	ISSUED FOR CONSTRUCTION
0	7/6/17	JDM	DH	MH	ISSUED FOR CONSTRUCTABILITY REVIEW



WATER MANAGEMENT PLAN NELPCo EAGLE GOLD MINE, YT					
LOWER DUBLIN SOUTH POND SECTIONS & DETAILS					
PROJECT NO.	OFFICE	DES	CKD	REV	DRAWING
WTRM03037-01	VANC	DH	MH	4	C1.05
DATE	SHEET No. of	DWN	APP	STATUS	
January 29, 2018		JDM	MH	REC	

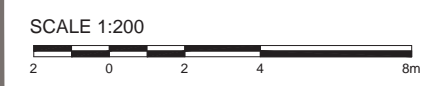

W:\local\hella\Legacy\Vancover\Drafting\Transportation\WTRM03037-01 - Eagle Gold Design - R3 RECORD.dwg [C1.05] January 29, 2018 - 3:56:49 pm (BY: MANG, JUSTIN)

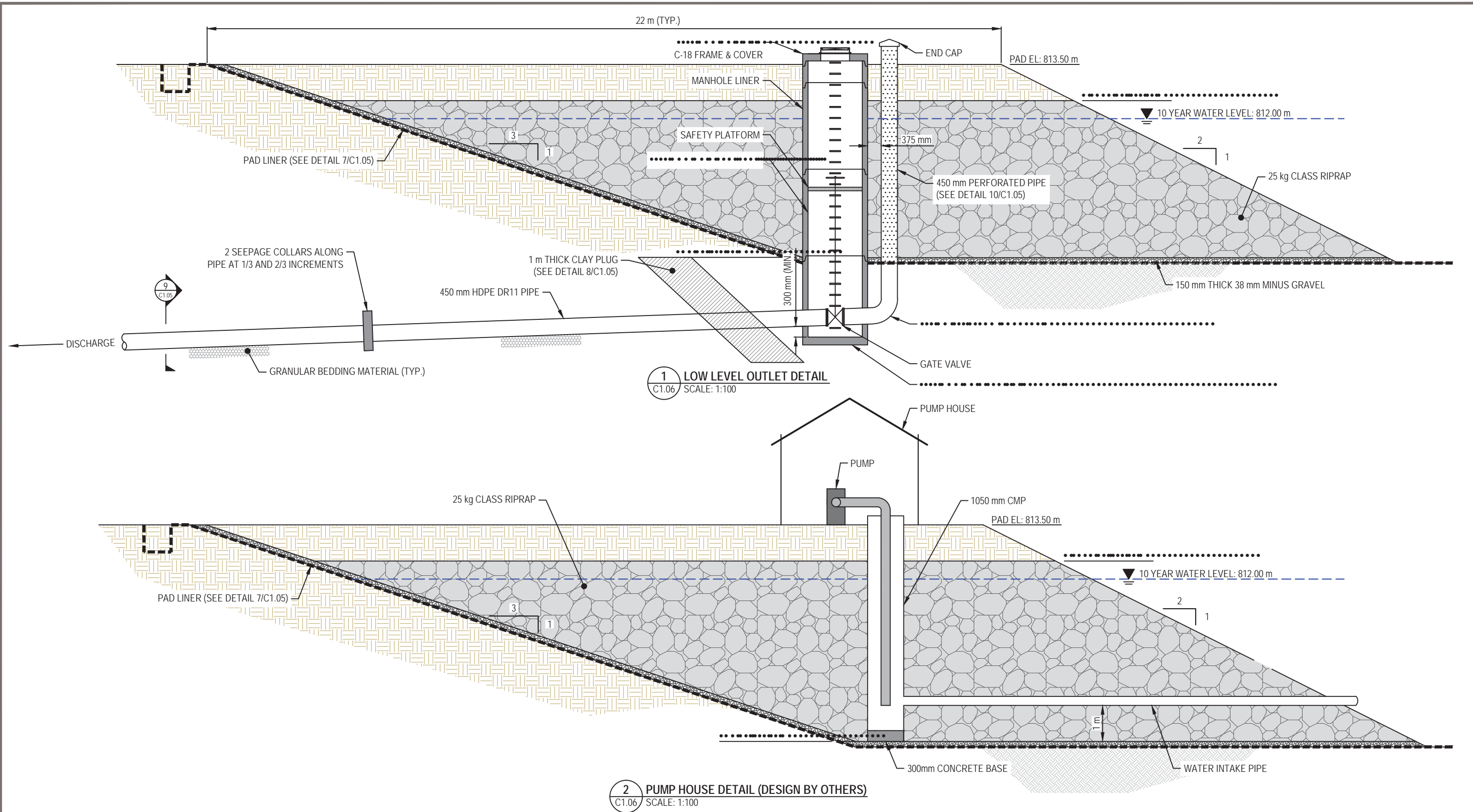

LEGEND

NOTES

SCALE 1:100

1 0 1 2 4m

PERMIT TO PRACTICE
TETRA TECH CANADA INC.
SIGNATURE: *[Signature]*
Date: *July 14/17*
PERMIT NUMBER PPO03
Association of Professional Engineers of Yukon

RECORD DRAWING

NUM	DATE	DWN	CKD	APR	DESCRIPTION
3	1/29/18	JDM	DH	MH	RECORD DRAWING
2	9/29/17	JDM	DH	MH	DESIGN CHANGE 001
1	7/14/17	JDM	DH	MH	ISSUED FOR CONSTRUCTION
0	7/6/17	JDM	DH	MH	ISSUED FOR CONSTRUCTABILITY REVIEW

PROFESSIONAL
YUKON
MAURIGIO HERRERA
TERRITORY
ENGINEER

PROFESSIONAL SEAL

CLIENT

StrataGold Corporation

TETRA TECH

**WATER MANAGEMENT PLAN
NELPCo EAGLE GOLD MINE, YT**

**LOWER DUBLIN SOUTH POND
LOW LEVEL OUTLET AND PUMP HOUSE**

PROJECT NO. WTRM03037-01	OFFICE VANC	DES DH	CKD MH	REV 3	DRAWING C1.06
DATE January 29, 2018	SHEET No. of	DWN JDM	APP MH	STATUS REC	

\\lcal\hcal\legacy\vancover\drafling\transportation\WTRM\WTRM03037-01\WTRM03037-01 - Eagle Gold Design - R3 RECORD.dwg [C1.06] January 29, 2018 - 2:03:24 pm (BY: MANG, JUSTIN)

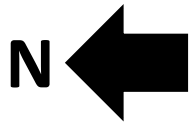

ROAD TO
DUBLIN GULCH

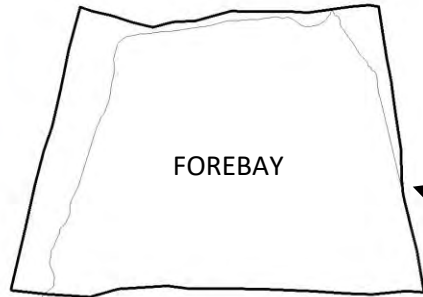

FOREBAY

AS-BUILT LINER
EXTENTS

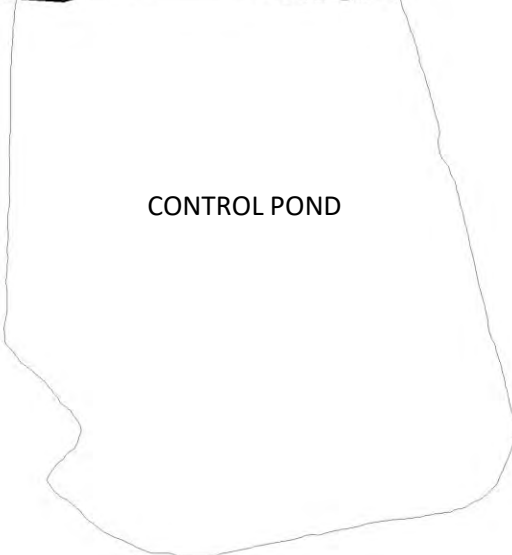

CONTROL POND

CRUSHER ACCESS ROAD



CAMP

NOTES

TITLE
AS-BUILT PLAN VIEW OF FOREBAY LINER

DOCUMENT TITLE	APPENDIX	PREPARED BY	REVIEWED BY	DATE	FIGURE
Forebay Lining Construction Report	APPENDIX D – As-built Figures	LJ	RT	2/20/2021	D-1



NOTES
 1) ADDITIONAL PHOTOS ARE ARCHIVED BY VICTORIA GOLD

TITLE
20201224 – AERIAL PHOTOGRAPH OF LINER DEPLOYED

DOCUMENT TITLE
 Forebay Lining Construction Report

APPENDIX
 APPENDIX C – Construction Photos

PREPARED BY
 LJ

REVIEWED BY
 RT

DATE
 2/20/2021

FIGURE
 D-11

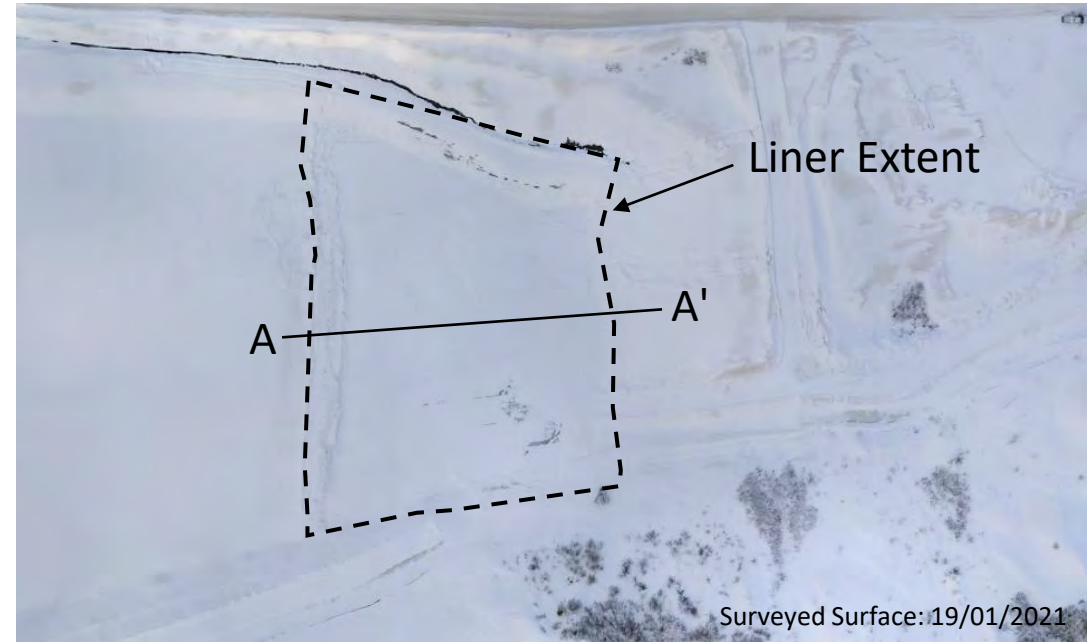
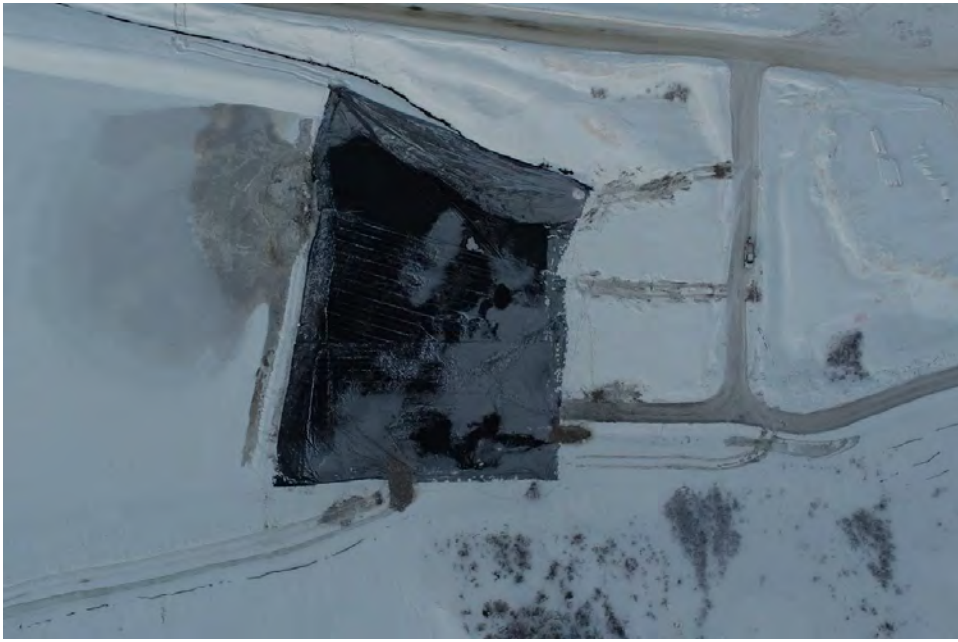

Section A – A'

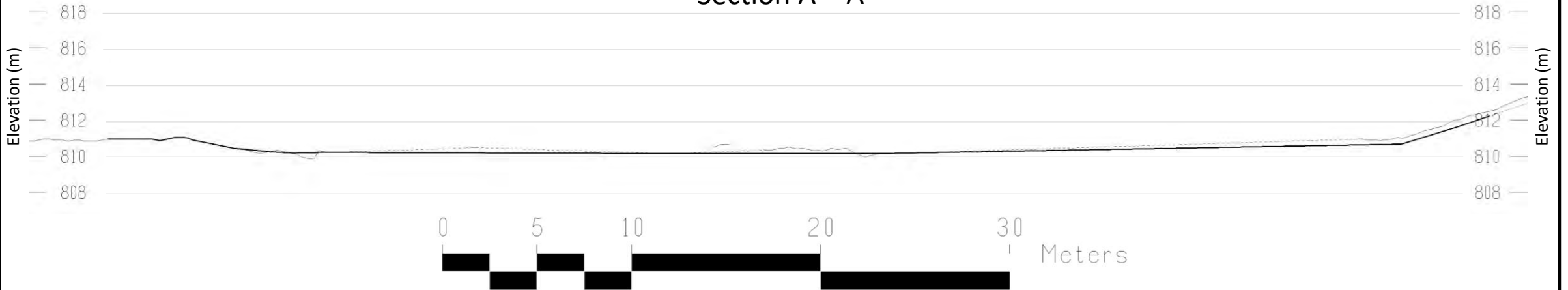

NOTES

- 1) LINER EXTENT SURVEYED BY HAND (14-01-2021) AND FOREBAY SURFACE SURVEYED BY DRONE (19-01-2021)
- 2) LINER BASE, SHOWN BY SOLID BLACK LINE ON CROSS SECTION, ESTIMATED UNDERNEATH SNOW COVER

DOCUMENT TITLE	APPENDIX	PREPARED BY	REVIEWED BY	DATE	FIGURE
Forebay Lining Construction Report	APPENDIX D – As-built Figures	LJ	RT	2/20/2021	D-2

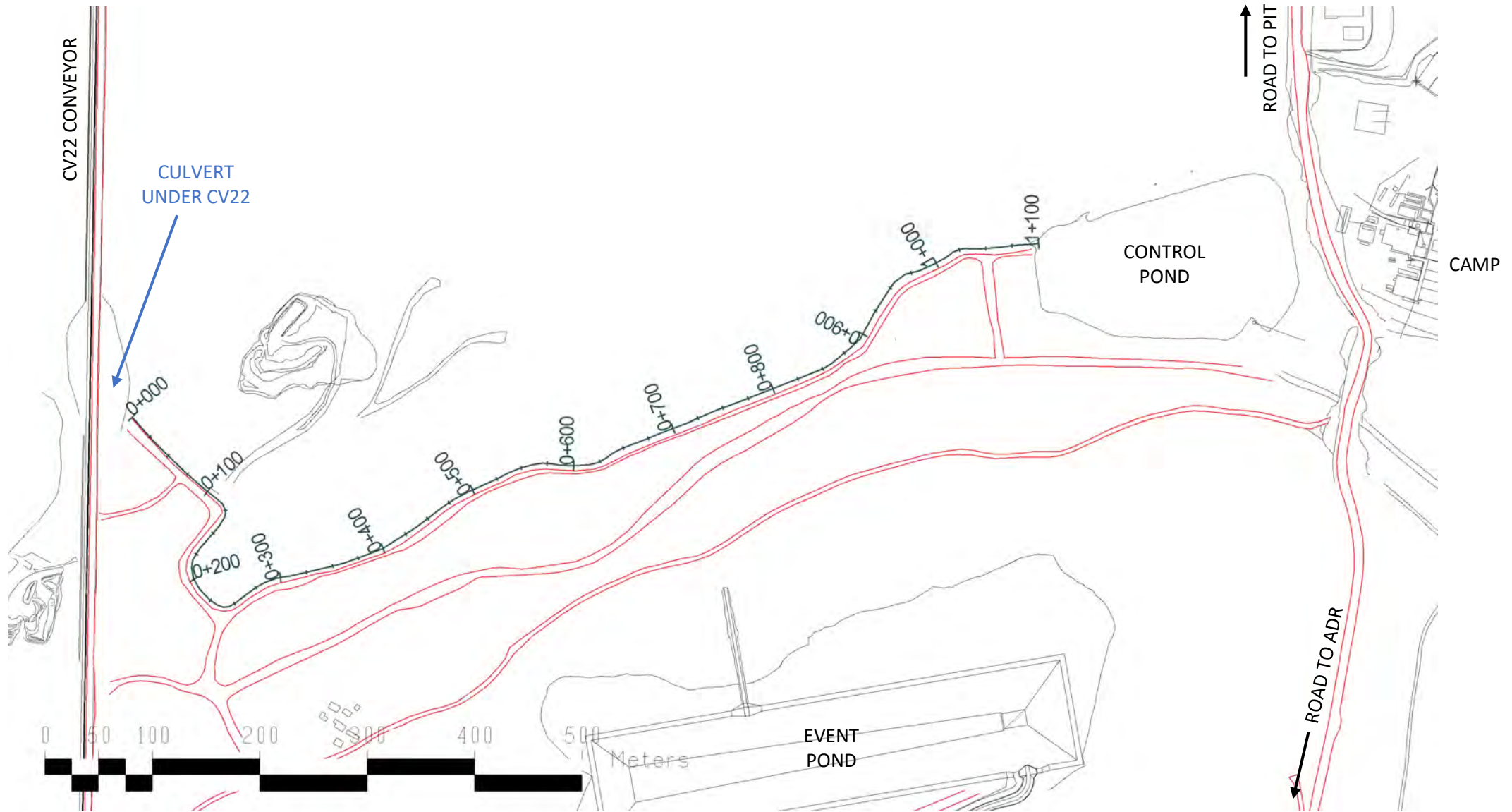
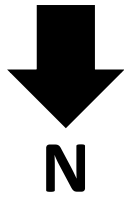

NOTES

TITLE
AS-BUILT PLAN VIEW OF DITCH B

DOCUMENT TITLE	APPENDIX	PREPARED BY	REVIEWED BY	DATE	FIGURE
Ditch B Construction Report	APPENDIX E – As-built Figures	LJ	RT	7/2/2021	E-1

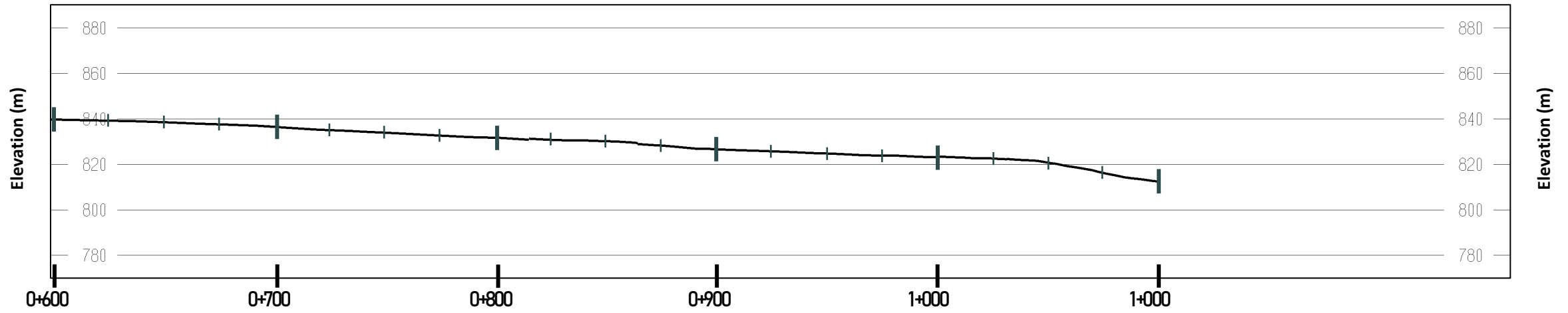
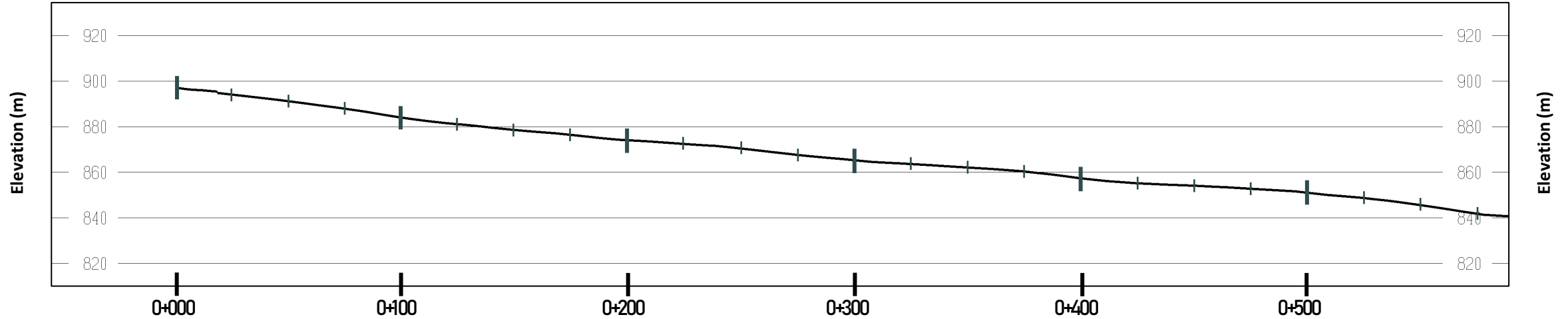

NOTES

TITLE

DITCH B PROFILE

DOCUMENT TITLE	APPENDIX	PREPARED BY	REVIEWED BY	DATE	FIGURE
Ditch B Construction Report	APPENDIX E – As-built Figures	LJ	RT	7/2/2021	E-2

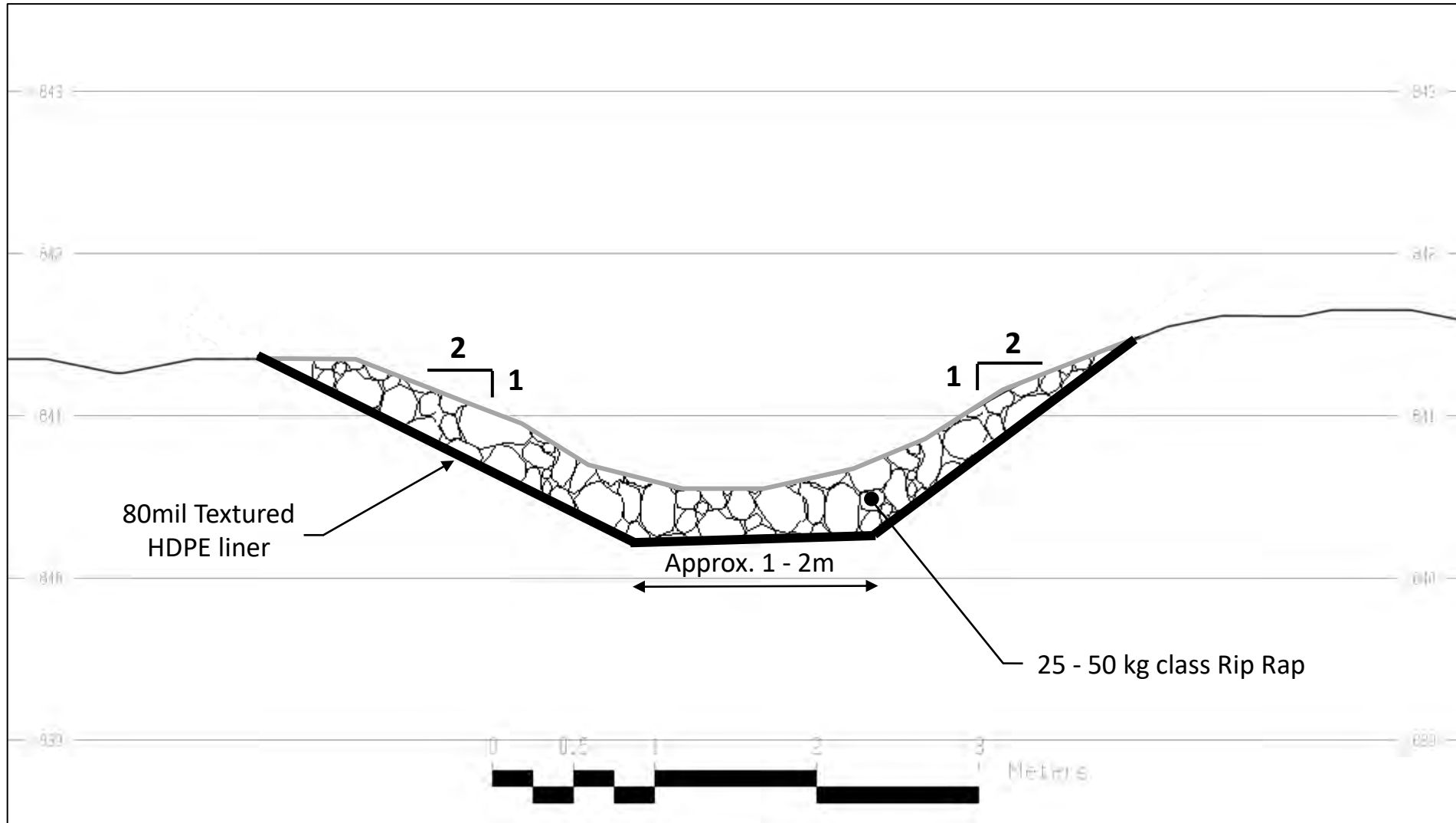

NOTES

TITLE
TYPICAL CROSS SECTION OF DITCH B

DOCUMENT TITLE
 Ditch B Construction Report

APPENDIX
 APPENDIX E – As-built Figures

PREPARED BY
 LJ

REVIEWED BY
 RT

DATE
 7/2/2021

FIGURE
 E-3

Path: O:\03-ENG\11 Projects\Ditch A Relining\2_Construction

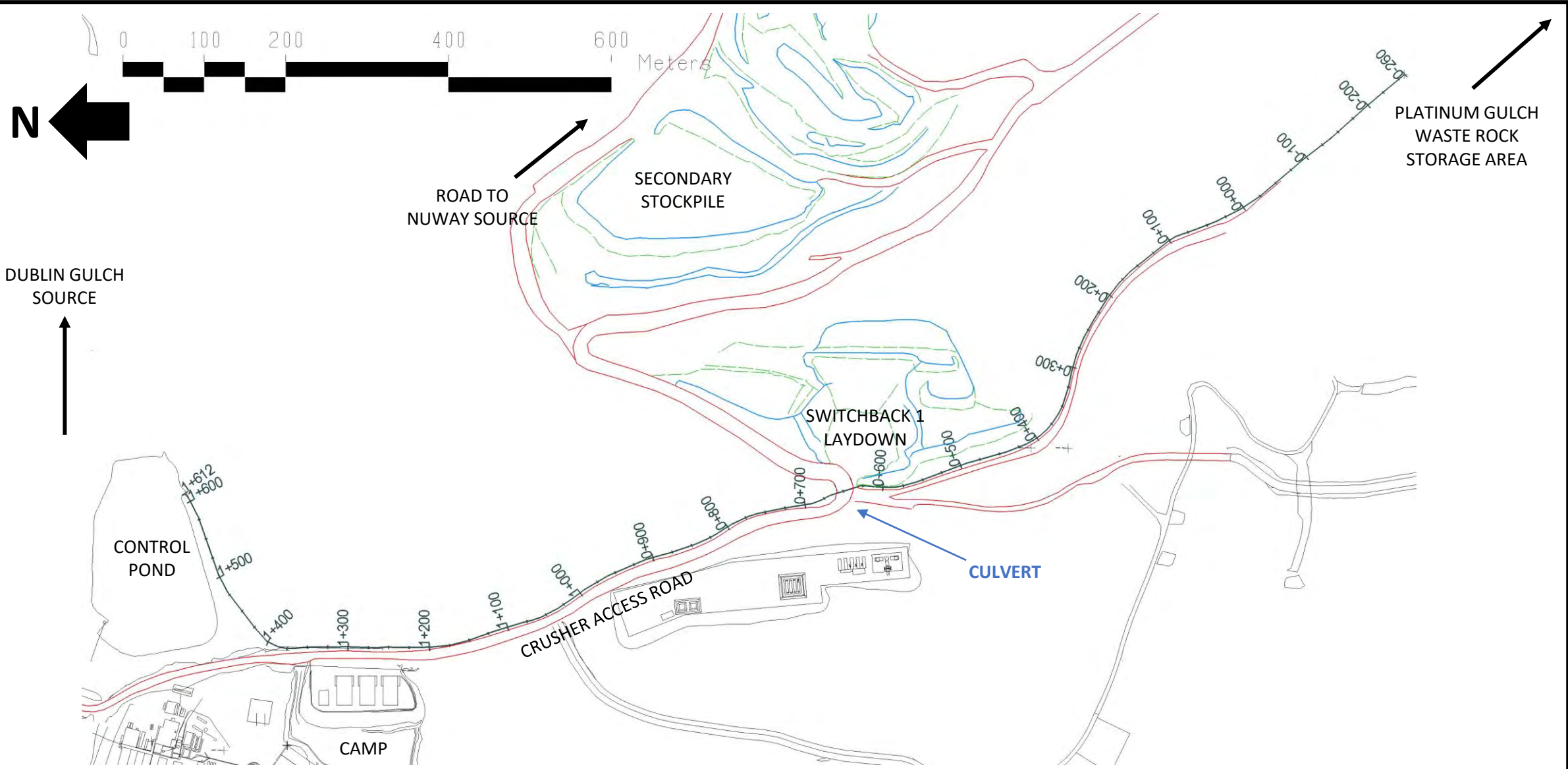

NOTES

TITLE
AS-BUILT PLAN VIEW OF DITCH A

DOCUMENT TITLE	APPENDIX	PREPARED BY	REVIEWED BY	DATE	FIGURE
Ditch A Improvement Construction Report	APPENDIX E – As-built Figures	LJ	RT	11/23/2020	E-1

TSX: VGCX OTC: VITFF VGCX.com

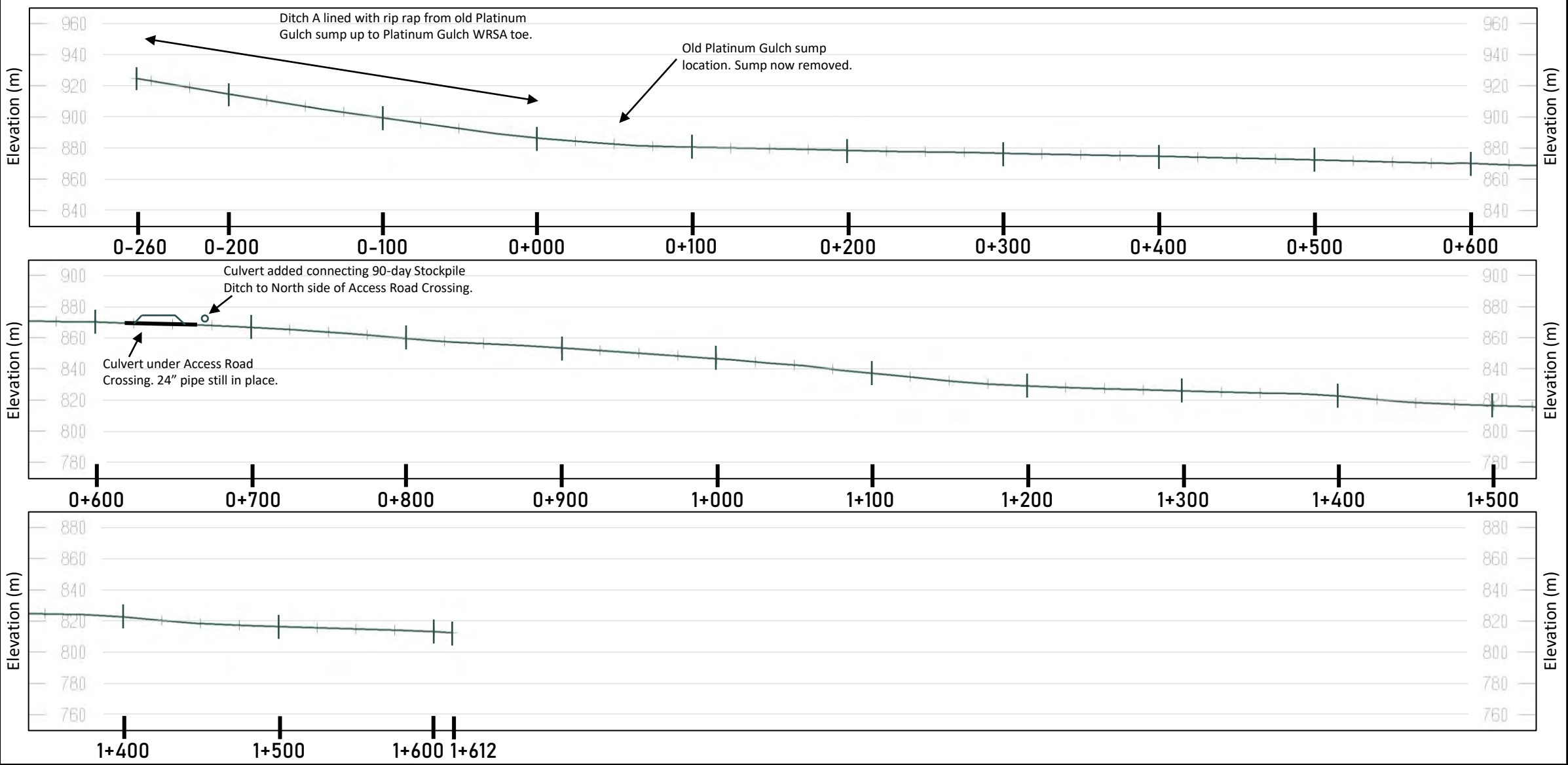

NOTES

TITLE
DITCH A PROFILE

DOCUMENT TITLE Ditch A Improvement Construction Report	APPENDIX APPENDIX E – As-built Figures	PREPARED BY LJ	REVIEWED BY RT	DATE 11/23/2020	FIGURE E-2
---	---	-------------------	-------------------	--------------------	---------------

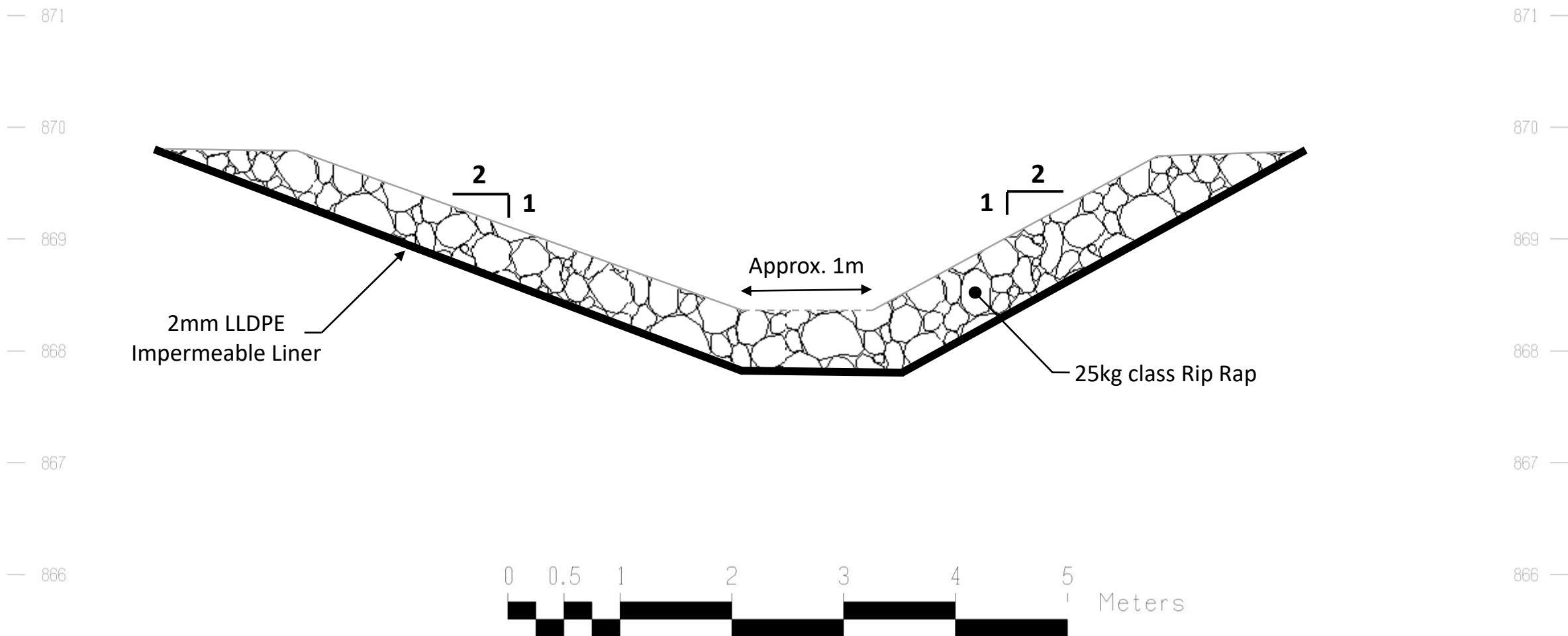

NOTES
 1) TOP OF RIP RAP IN BASE OF DITCH APPROXIMATED AS DITCH HAD ICE IN IT DURING SURVEY

TYPICAL CROSS SECTION OF DITCH A

DOCUMENT TITLE	APPENDIX	PREPARED BY	REVIEWED BY	DATE	FIGURE
Ditch A Improvement Construction Report	APPENDIX E – As-built Figures	LJ	RT	11/23/2020	E-3

\\local\hah\Legacy\Vancouver\Drawings\Transportation\WTRM\WTRM03037-01 - Eagle Gold Ditch Design_REC.dwg [C1.00] [May 17, 2019 - 2:54:43 pm (BY: MANG, JUSTIN)]

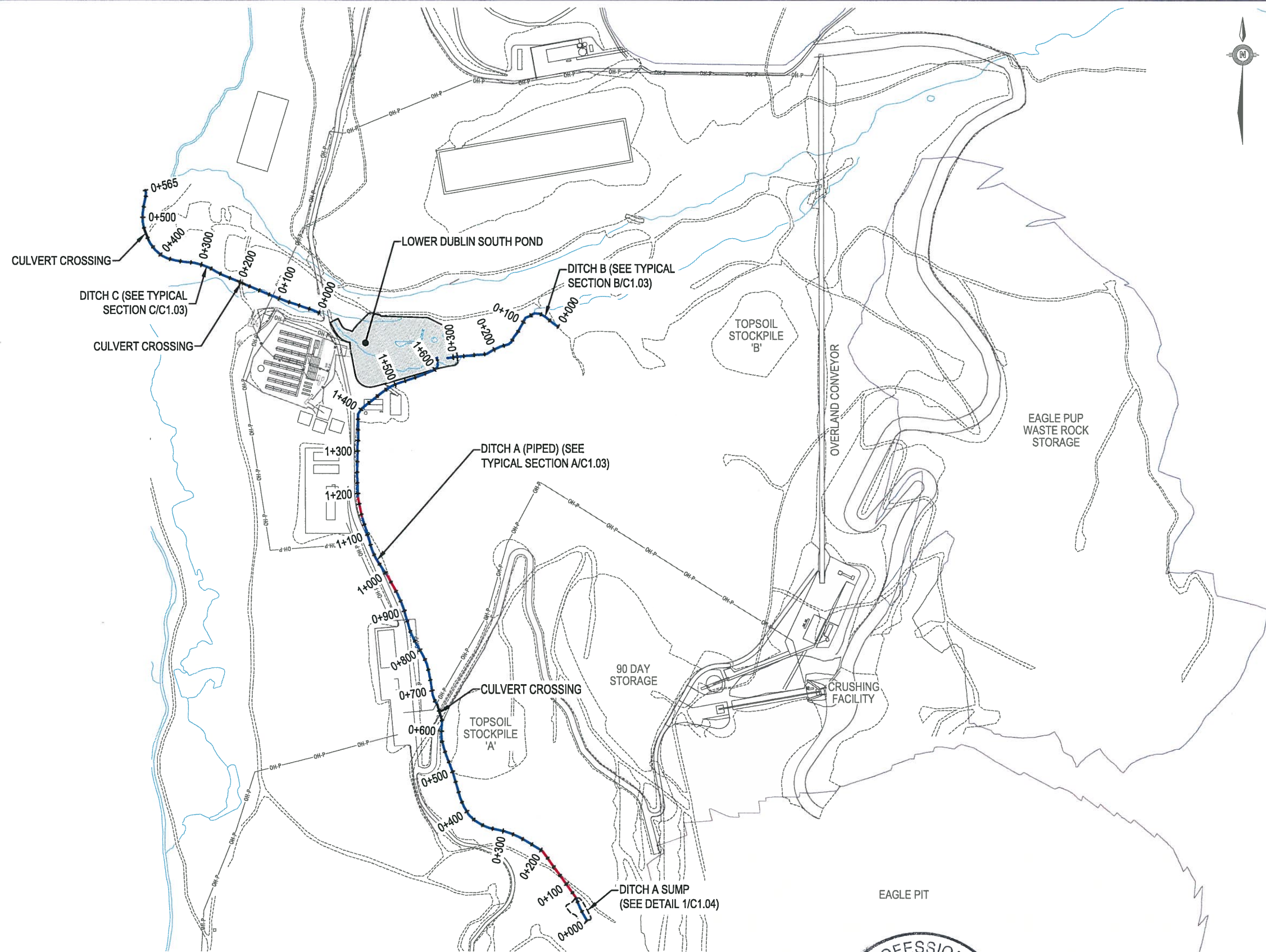

LEGEND
— Inferred Ditch

NOTES

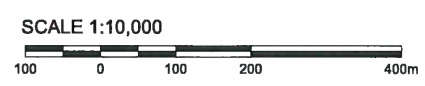

RECORD DRAWING

NUM	DATE	DWN	CKD	APR	REVISIONS	DESCRIPTION
0	5/17/19	JDM	MH	MH	RECORD DRAWING	



**WATER MANAGEMENT PLAN
 NELPCo EAGLE GOLD MINE, YT**

DITCH DESIGN PLAN

PROJECT NO. WTRM03037-01	OFFICE VANC	DES MH	CKD MH	REV 0	DRAWING C1.00
DATE May 17, 2019	SHEET No. of	DWN JDM	APP MH	STATUS REC	

\\t.local\ba\Legacy\Vancouver\Drafting\Transportation\WTRM\WTRM03037-01 - Eagle Gold Ditch Design_REC.dwg [C1.01] May 17, 2019 - 2:25:02 pm (B.Y. MANG, JUSTIN)

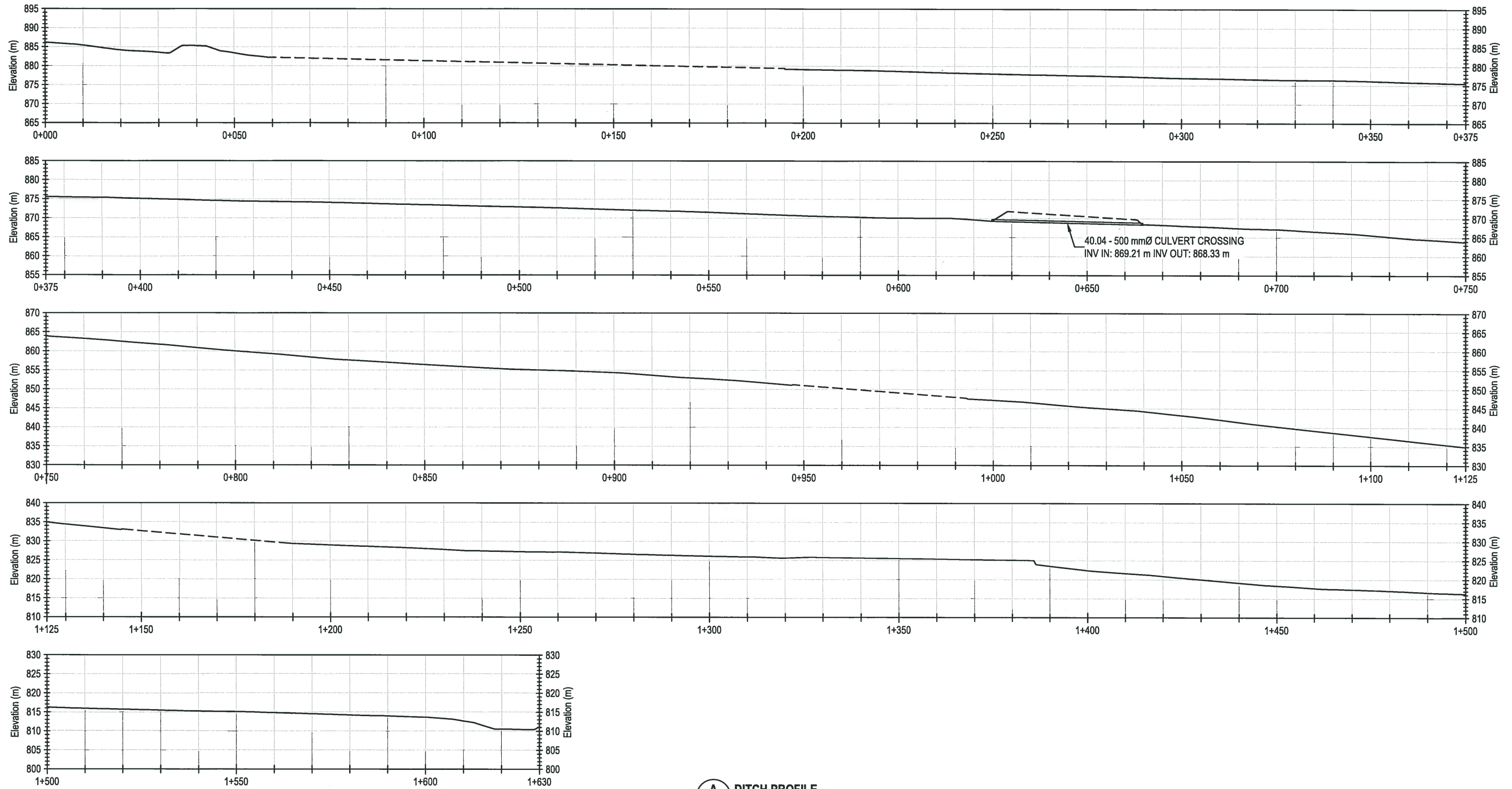

A DITCH PROFILE
C1.01 SCALE: 1:1000

LEGEND
 — As Built Profile
 - - - Inferred Profile (See Note 2)

NOTES
 1. As Built survey completed on April 14, 2019.
 2. Ditch profile is inferred due to ice presence at time of survey.



RECORD DRAWING

NUM	DATE	DWN	CKD	APR	DESCRIPTION
0	5/17/19	JDM	MH	MH	RECORD DRAWING



**WATER MANAGEMENT PLAN
NELPCo EAGLE GOLD MINE, YT**

DITCH PROFILES					
PROJECT NO. WTRM03037-01	OFFICE VANC	DES MH	CKD MH	REV 0	DRAWING C1.01
DATE May 17, 2019	SHEET No. of	DWN JDM	APP MH	STATUS REC	

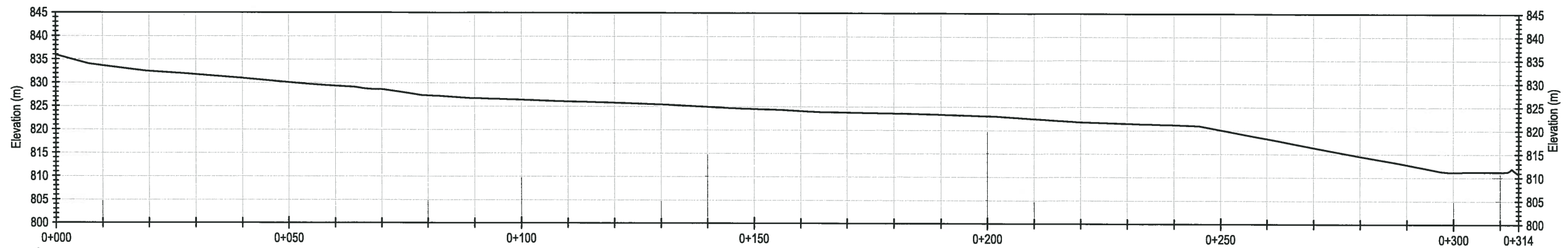

B DITCH PROFILE
C1.02 SCALE: 1:1000

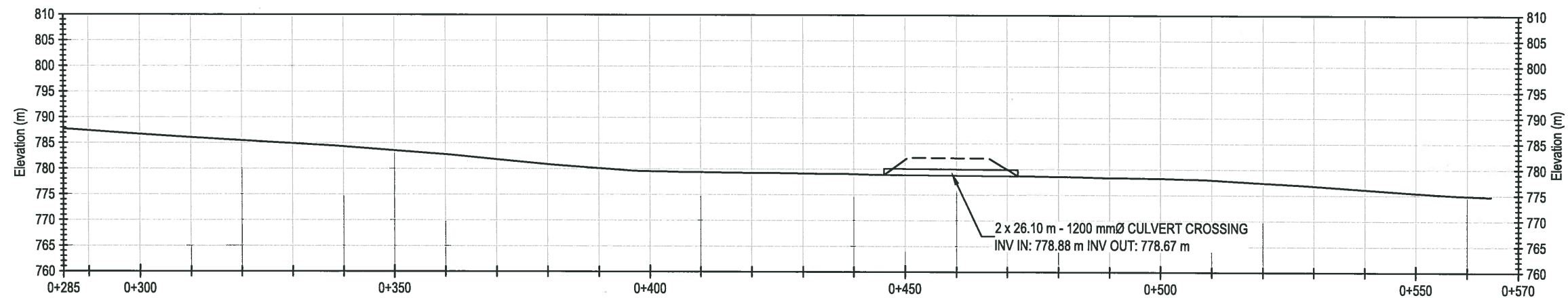
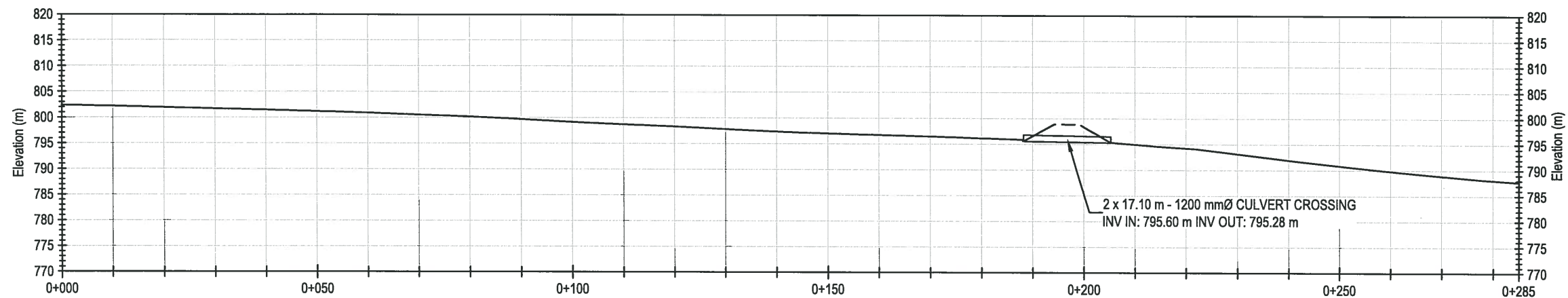

C DITCH PROFILE
C1.02 SCALE: 1:1000

LEGEND

- As Built Profile
- - - Inferred Profile (See Note 2)

NOTES

1. As Built survey completed on April 14, 2019.
2. Ditch profile is inferred due to ice presence at time of survey.

SCALE 1:1000



RECORD DRAWING

NUM	DATE	DWN	CKD	APR	DESCRIPTION
0	5/17/19	JDM	MH	MH	RECORD DRAWING



**WATER MANAGEMENT PLAN
NELPCo EAGLE GOLD MINE, YT**

DITCH PROFILES

PROJECT NO. WTRM03037-01	OFFICE VANC	DES MH	CKD MH	REV 0	DRAWING C1.02
DATE May 17, 2019	SHEET No. of	DWN JDM	APP MH	STATUS REC	

I:\local\lab\Legacy\ancouver\Drafting\Transportation\WTRM\WTRM03037-01\WTRM03037-01.dwg [C1.02] May 17, 2019 - 3:06:47 pm (BY: MANG, JUSTIN)

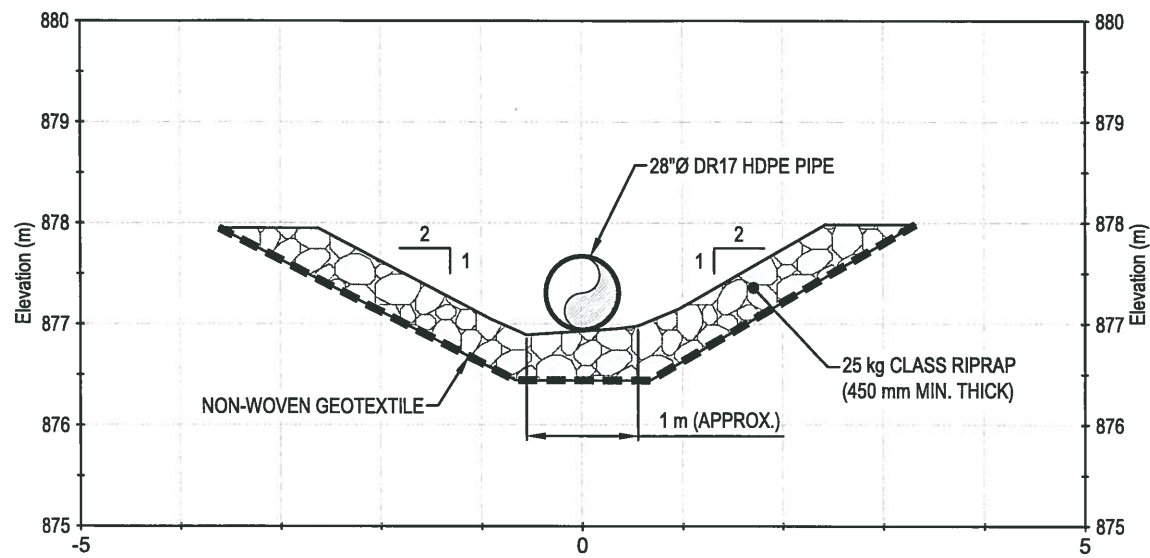

A TYPICAL DITCH SECTION
C1.03 SCALE: 1:75

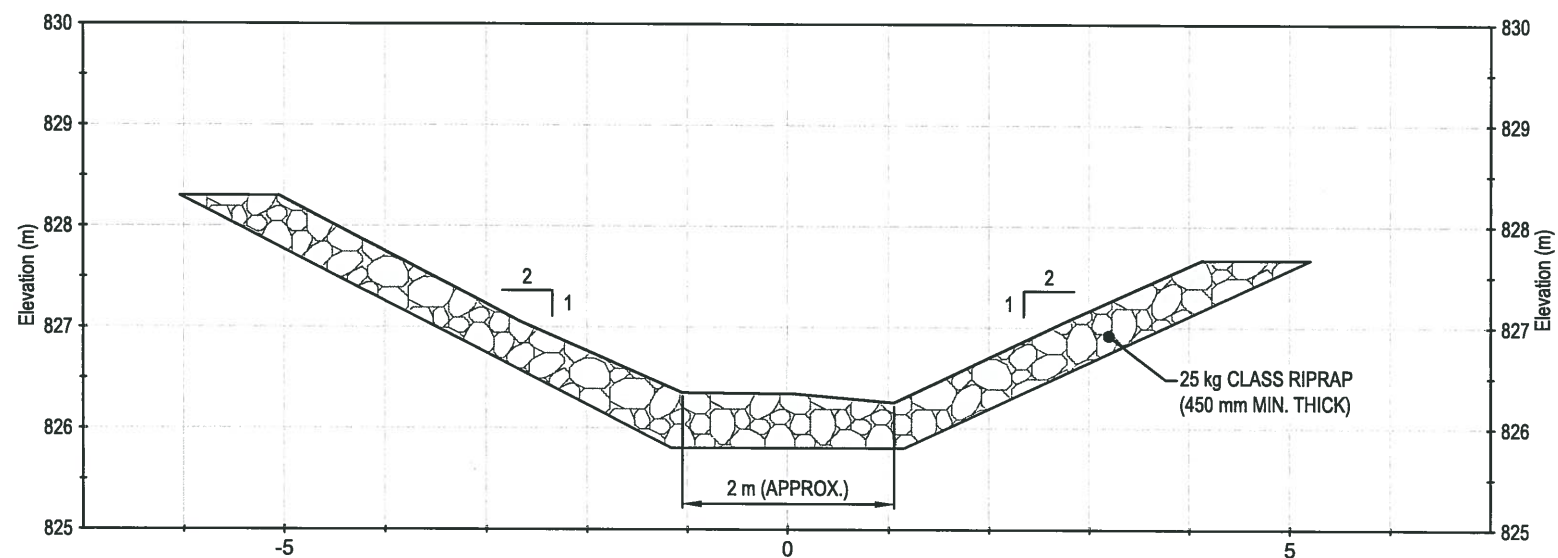

B TYPICAL DITCH SECTION
C1.03 SCALE: 1:75

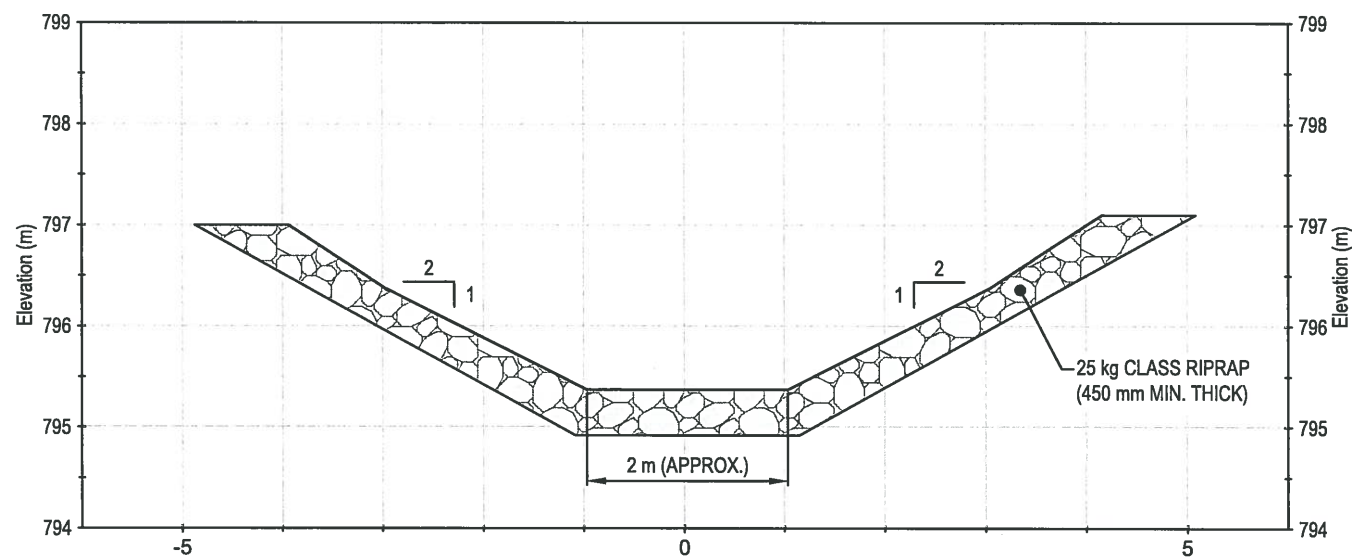

C TYPICAL DITCH SECTION
C1.03 SCALE: 1:75

LEGEND

NOTES

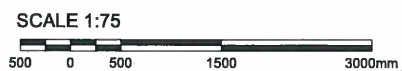

RECORD DRAWING

NUM	DATE	DWN	CKD	APR	DESCRIPTION
0	5/17/19	JDM	MH	MH	RECORD DRAWING



**WATER MANAGEMENT PLAN
NELPCo EAGLE GOLD MINE, YT**

DITCH CROSS SECTIONS

PROJECT NO. WTRM03037-01	OFFICE VANC	DES MH	CHK MH	REV 0	DRAWING C1.03
DATE May 17, 2019	SHEET No. of	DWN JDM	APP MH	STATUS REC	

\\t\local\label\Legacy\Vancouver\Drafting\Transportation\WTRM\WTRM03037-01\WTRM03037-01 - Eagle Gold Ditch Design_REC.dwg [C1.03] May 17, 2019 - 3:04:17 pm [B.V. MANG, JUSTIN]

W:\local\Legacy\Projects\Transportation\WTRM\WTRM03037-01 - Eagle Gold Ditch Design_REC.dwg [C1.04] May 17, 2019 - 12:23:21 pm (BY: MANG, JUSTIN)

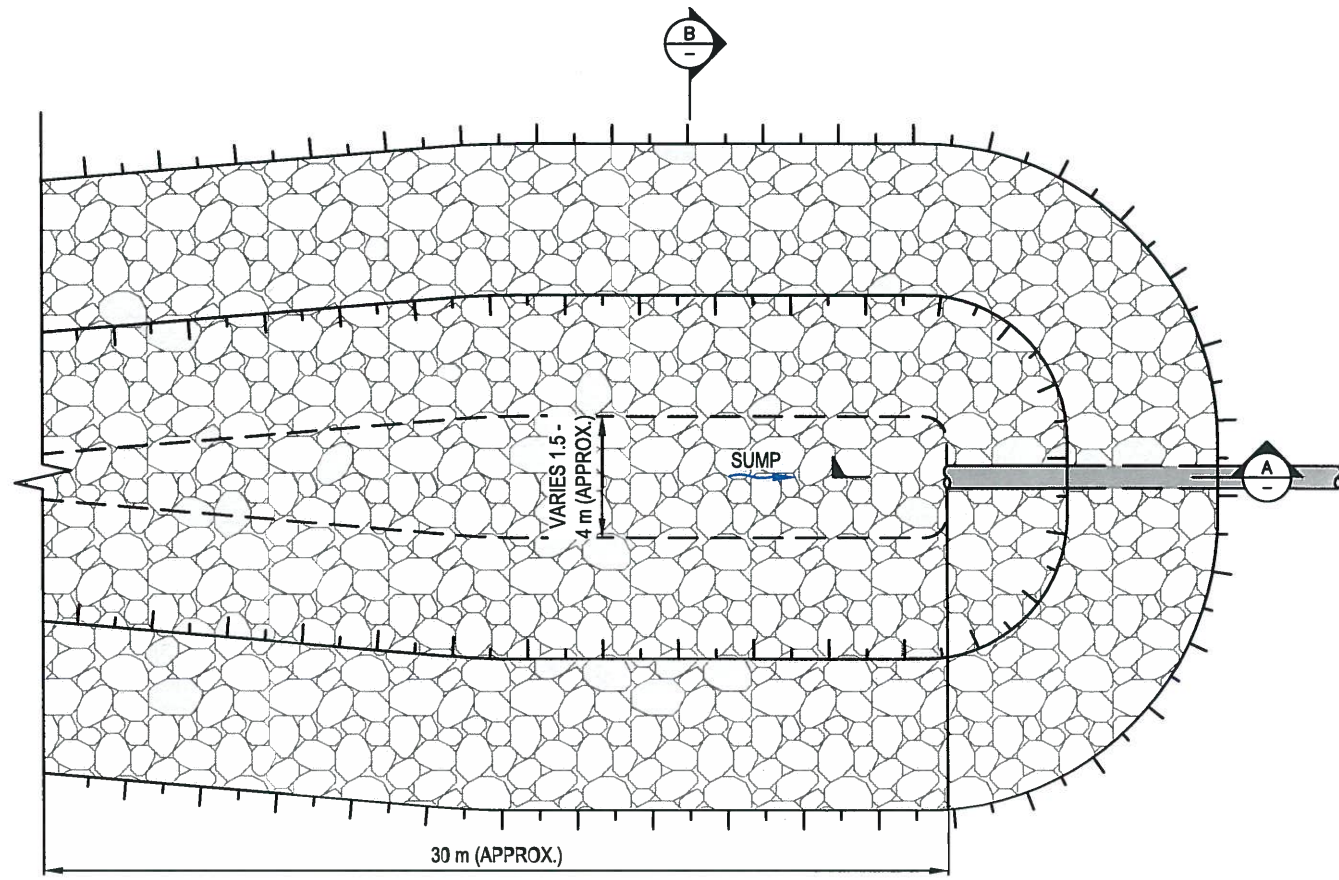

PLAN

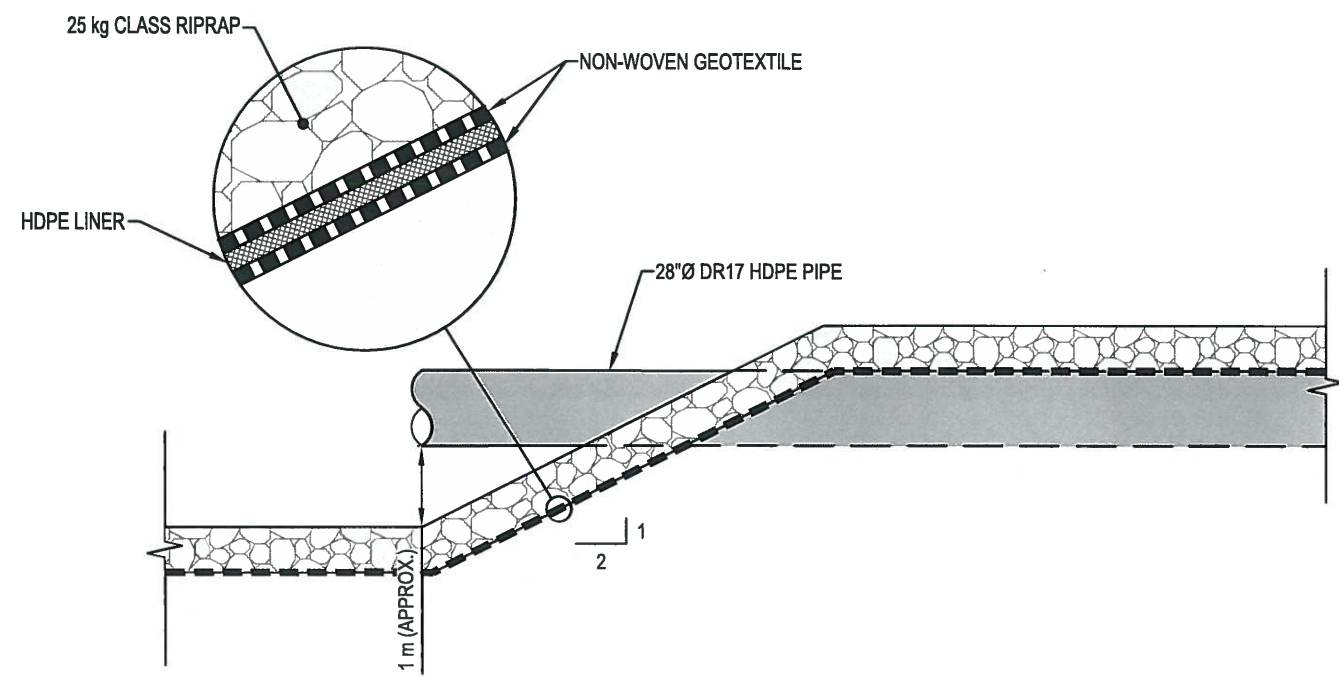

SECTION A

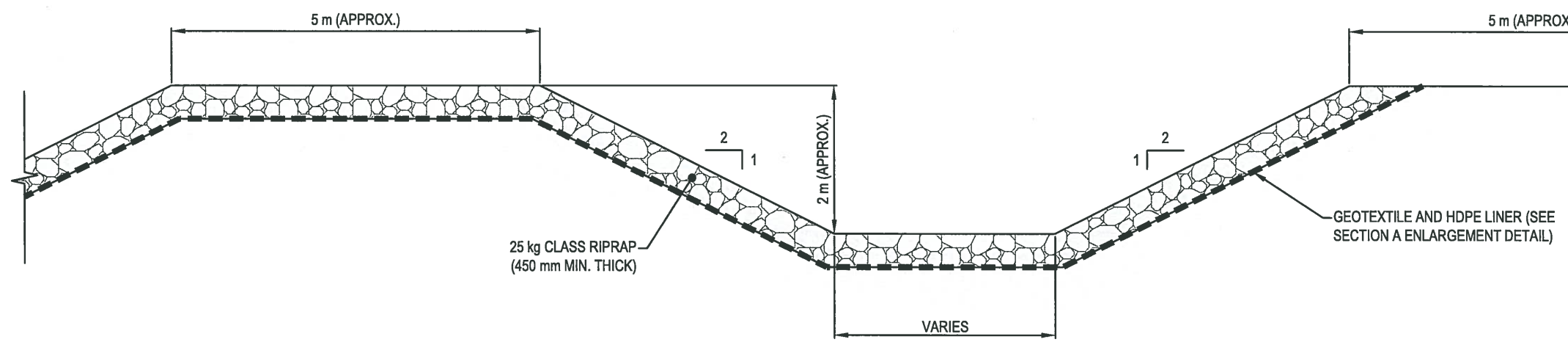

SECTION B

1 SUMP DETAIL
C1.04 SCALE: NTS

LEGEND NOTES

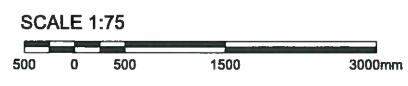

RECORD DRAWING

NUM	DATE	DWN	CKD	APR	DESCRIPTION
0	5/17/19	JDM	MH	MH	RECORD DRAWING
REVISIONS					

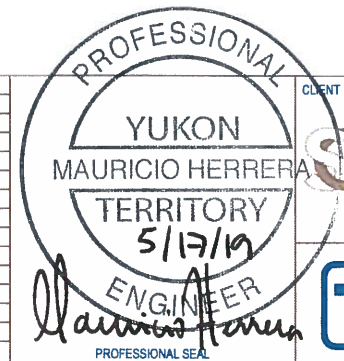

WATER MANAGEMENT PLAN
NELPCo EAGLE GOLD MINE, YT

DETAILS					
PROJECT NO.	OFFICE	DES	CKD	REV	DRAWING
WTRM03037-01	VANC	MH	MH	0	C1.04
DATE	SHEET No.	DWN	APP	STATUS	
May 17, 2019	of	JDM	MH	REC	