



Closure Water Conveyance System Design Update Report, Minto Mine

Prepared for

Minto Explorations Ltd.



Prepared by



SRK Consulting (Canada) Inc.
1CM002.042
August 2016

Closure Water Conveyance System Design Update Report, Minto Mine

August 2016

Prepared for

Minto Explorations Ltd.
P.O. Box 33174
Whitehorse, YT Y1A 6S1
Canada

Tel: +1 604 759 0860
Web: www.capstonemining.com

Prepared by

SRK Consulting (Canada) Inc.
2200-1066 West Hastings Street
Vancouver, BC V6E 3X2
Canada

Tel: +1 604 681 4196
Web: www.srk.com

Project No: 1CM002.042

File Name: Minto_1CM002-042_ClosureConveyance_20160805_SDM_VM_dbm

Copyright © SRK Consulting (Canada) Inc., 2016

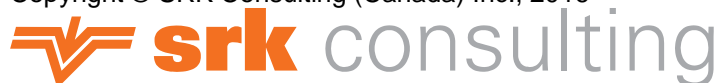

Table of Contents

1	Introduction	1
2	Water Management Review	2
2.1	Hydrology Review	2
2.2	Climate Change Analysis.....	2
2.3	Channel Routing Options Evaluation.....	3
3	Design Overview and Criteria	4
3.1	Design Overview.....	4
3.2	Design Criteria	5
4	Methodology	7
4.1	Design Flow Estimates	7
4.2	Conveyance Channel Typical Geometry and Erosion Protection	7
4.2.1	Riprap Calculations	8
4.2.2	Manning’s Roughness Estimation.....	9
4.2.3	Riprap Classification and Gradation for Conveyance Channels.....	9
5	Closure Conveyance Channel Design	10
5.1	Channel A	10
5.1.1	W15 Tributary Intake.....	11
5.2	Channel B	11
5.2.1	W35A Tributary and South Diversion Ditch Intake	11
5.2.2	Tailings Diversion Ditch Pipe Deactivation	11
5.2.3	Spillway into Area 2 Stage 3 Pit.....	11
5.3	Channel C	12
5.3.1	Confluence Design Channel E, D, and C.....	12
5.3.2	Main Pit Discharge Channel Transition Section	12
5.3.3	Channel C Access Road	12
5.4	Channel D.....	13
5.4.1	Area 2 Pit Discharge Transition Section	13
5.5	Channel E	13
5.5.1	E1 and E2 Pilot Channel and Geomembrane Seepage Management.....	14
5.5.2	E3 Channel	15
5.6	Stilling Basin	15
5.7	High Flow Bypass Channel.....	15
5.8	Primary and Secondary Head Ponds	15
6	Integrating Vegetation Erosion Protection	16
7	Information Required to Advance the Channel Design	17
8	References	19

List of Tables

Table 1: Riprap Class Gradation.....	10
Table 2: Design Summary for Closure Conveyance Channel A.....	10
Table 3: Design Summary for Closure Conveyance Channel B.....	11
Table 4: Design Summary for Closure Conveyance Channel C.....	12
Table 5: Design Summary for Closure Conveyance Channel D.....	13
Table 6: Design Summary for Closure Conveyance Channel E.....	14
Table 7: Design Summary for Closure Conveyance High Flow Bypass Channel	15
Table 8: Selected Biotechnical Techniques based on Landform.....	16

Appendices

- Appendix A – Conveyance System Drawings
- Appendix B – Site-Specific Hydrology Review
- Appendix C – Climate Change Analysis
- Appendix D – Channel Routing Options Evaluation
- Appendix E – Integrating Vegetation Erosion Protection

1 Introduction

SRK Consulting (Canada) Inc. has prepared this updated closure water conveyance system design report for Minto Mine located in Yukon, Canada, and operated by Minto Explorations Ltd. The updated designs are intended to form a part of Minto's August 2016 update of the mine's Reclamation and Closure Plan (RCP 2016-01), and they are based on a November 2015 as-built topographic surface provided by Minto and a revised life-of-mine (LOM) plan. The updated designs also account for the following:

- Construction of the Mill Valley Fill Extension Stage 2 using Minto North waste rock;
- Creation of the Main Pit Dump within the footprint of the mined-out Main Pit;
- Redesign of the Area 2 Stage 3 Pit;
- Removal of the Ridgetop North Pit, the Ridgetop South Pit, and the Ridgetop Waste Dump from the current LOM plan;
- Removal of the Main Dam (a tailings dam) that had been designed to increase the storage capacity of the Main Pit Tailings Management Facility from the previous LOM plan;
- Reconfiguration of the existing Water Storage Pond footprint for an engineered wetland; and
- Engineering of the landform design and waste rock dump cover systems.

Because of these revisions, the existing closure designs for the water conveyance network and related infrastructure required updates, which are included in this report to a preliminary design level. Secondary and tertiary drainage features and swales are not included in the preliminary engineering design; however, they will be included at later stages of closure design and should be incorporated into future stages of closure cover design. It is anticipated the design of the secondary and tertiary drainage features will not have a significant influence on the design of the primary conveyance network.

The closure conveyance system is a network of channels, erosion protection features, and energy dissipation structures that convey surface water from and through the mine site to Minto Creek, which itself discharges into the Yukon River. This design report focuses on the primary arterial network of conveyance channels within the mine footprint. The network of channels is designed to collect, intercept, and convey water through the mine in its closed state. To support the conveyance system designs and methodology summarized in this report, the following technical memos are provided in the appendices:

- Appendix A – Conveyance System Drawings,
- Appendix B – Site-Specific Hydrology Review,
- Appendix C – Climate Change Analysis,
- Appendix D – Routing Flow Closure Evaluation, and
- Appendix E – Integrating Vegetation Erosion Protection.

2 Water Management Review

To support the updates to the conveyance designs, SRK has reviewed and updated the site-wide hydrology models to reflect climate change, modified watershed catchment areas and assessed options of alignments for conveyance channels. The results of these reviews are summarized below. Further details are provided in the technical memos (Appendices B, C and D).

2.1 Hydrology Review

This section summarizes the background and results of a site wide hydrology review which is included with this report in Appendix B.

The updated hydrology models were used to estimate the summer probable maximum precipitation (PMP), probable maximum flood (PMF), and 1:200 year peak flows, which are main components to the conveyance designs of channels and erosion protection required in the Minto Mine Reclamation and Closure Plan (RCP).

The maximum instantaneous flows from the return-period peak flows to PMF were calculated using a rainfall-runoff methodology where maximum average daily snowmelt was modelled as baseflow. The Soil Conservation Service method was used to determine runoff based on catchment area characteristics such as: lag time, area, and curve number coefficients. The Soil Conservation Service Type I rainfall distribution was selected for use in the HEC-HMS (2013) model. The Type I distribution approximates an intense, short-duration storm event typical of storms in the Yukon and nearby Alaskan interior. The HEC-HMS model was developed to model the Minto mine site region to determine the 1:200 year return-period peak flows and PMF along the closure conveyance channels.

The PMP for a 24-hour duration event was evaluated using data from 20 regional meteorological stations; the same stations were used in the analysis for MAP. The analysis of the data was performed in RStudio software, generating a PMP estimate for each of the 20 regional stations. The results are presented in Appendix B, which presents a 24-hour PMP for the site of 159 mm of precipitation.

2.2 Climate Change Analysis

This section summarizes the background and results of the climate change study which is included with this report in Appendix C.

The International Panel on Climate Change (IPCC) projects a 5°C to 6°C increase in the ambient temperature in Northern Canada for year 2100 relative to the 1980 to 1999 temperatures (IPCC 2007). Evaluating the climate change models relative to Minto Mine, the mean annual air temperature has the potential to increase 3.3°C over the next century. Trending forward in time, the mean annual air temperatures may reach -0.8°C, 0.2°C, and 1.1°C in the 2020s, 2050s, and 2080s, respectively.

According to the climate change model, the total precipitation at Minto is forecasted to increase 67.9 mm (15%) during the LOM (2011 to 2040) and 199.3 mm (44%) by 2100. Heavy rainfall, which is the fraction of annual precipitation greater than the 95th percentile, is predicted to increase by 96% over the next century at Minto. Similarly, the number of days with more than 10 mm of rainfall is forecasted to increase by 140%. This trending increase in annual precipitation is reflected by the sizing and specifications of conveyance structures designed to accommodate future flows (Section 3).

The monthly average snow depth at Minto is expected to decrease over the next century. Based on models from 1979 to 2005 and 1979 to 2014 the density of the snow increases during the winter months. This increasing density trend is coupled to predictions of snow melt, precipitation, and temperature increases. Predictions forecast freshet will occur in May, and maximum daily snowmelt will decrease over the next century. The predicted maximum daily snowmelt in years 2071 to 2100 is half that of the snowmelt recorded from 1979 to 2005.

2.3 Channel Routing Options Evaluation

This section summarizes the results of a routing options review for the alignment of conveyance channels which are designed in this report. The full routing review is included with this report in Appendix D.

The Minto routing flow closure evaluation assessed channel design options for surface water flow received by the Main and Area 2 open pits. Three precipitation return period events were modelled: a 2-year peak flow, a 200-year peak flow, and a probable maximum flood (PMF).

Flow routing alternatives include two options for the Area 2 Pit:

- Option 1 – Area 2 Pit upstream flow is routed into Area 2 Pit through Channel B. From the pit, the flows are discharged through channel width, which becomes Channel D.
- Option 2 – Area 2 Pit catchment is diverted into Channel B, which bypasses the Area 2 Pit.

Three geometric channel configurations for the Main Pit and the two options for the Area 2 Pit were assessed:

- Case 1 – Minimum spillway width (2 m)
- Case 2 – Constructible spillway width, based on dozer sizing (7 m)
- Case 3 – Maximum spillway width, based on topography (22 m for Main Pit, 15 m for Area 2 Pit)

The results of the two routing options illustrate a minimal difference in impact from diverting runoff around the Area 2 Pit as opposed to through the pit. Furthermore, the diversion Option 2 does not result in a difference in the magnitude of peak flow or the timing of arrival of peak flows in lower Minto Creek relative to unattenuated catchments in the remainder of the watershed.(when compared to routing flows through the Area 2 Pit).

Based on the results of the analyses and the constructability, it is recommended that the Option 1 channel alignment for the Area 2 Pit and the Case 2 channel width option for both open pits be implemented. The Option 1 channel alignment has the further advantage of minimizing the length of channel underlain by deep permafrost overburden, and thereby minimizes the likelihood that long-term thaw consolidation will cause there to be a need for substantial long term maintenance efforts.

3 Design Overview and Criteria

The Minto site is centralized within contributing watershed catchments. Mine impacted surface runoff from the catchments reports to the Main Pit (Drawing CC-01; Appendix A). The overarching criteria of the conveyance channel design is to collect water reporting from contributing catchment areas and convey it through the mine site to Minto Creek east of the present location of the Water Storage Dam. Conveyed water must be contained in a channel designed for the 1:200 peak flow event and armoured with rock rip rap for erosion protection. Channel alignments should consider the effects of a PMF flow event such that the post-PMF channel alignment remains unchanged from the preceding alignment.

The open pits are utilized to collect and route flows from the upgradient conveyance channels and contributing catchments to provide an area where energy can be attenuated and where suspended sediments can be deposited. Designed channel slopes and alignments are selected to minimize excavations and potential erosion wherever practical.

The conveyance channel system is composed of six main conveyance channels, the Stilling Basin, the Primary Head Pond, and the Secondary Head Pond.

3.1 Design Overview

An overview of the elements of the closure conveyance design is provided below:

- **Conveyance Channel A.** Located southwest of the Main Pit, between the Main Waste Dump (MWD) and the Southwest Waste Dump (SWD). This channel will convey surface water from the W15 tributary across the South Wall Buttruss to the lake in the Main Pit.
- **Conveyance Channel B.** Located East of the Area 2 Stage 3 Pit. This channel collects flow from the Airport Road Ditch and from the W35A tributary and conveys it to the Area 2 Stage 3 Pit. The channel alignment will incorporate a light vehicle swale crossing to maintain access to the underground portal to the south of the channel (South Portal).
- **Conveyance Channel C.** Channel C conveys discharge water from the Main Pit to a point of confluence with Channel D, where the two combine to form Channel E1. The confluence of flows from Channel C and D requires additional design attention to ensure flow transitions don't result in channel erosion. Additionally, a constructed access road is required to maintain access to Channel C and the Main Pit for post-closure monitoring and maintenance.
- **Conveyance Channel D.** Channel D conveys the discharge water from the Area 2 Pit to the confluence with Channel C. Similar to Channel C, the channel design also includes a parallel

access road, and the channel where the two flows converge will need to be further designed to resist erosion.

- **Conveyance Channel E.** Channel E has been subdivided into a system of three sequential channels: E1, E2, and E3. Channel E ultimately conveys water from the Main and Area 2 open pits to the present location of the Water Storage Pond (WSP) area, where a portion of the discharge is integrated into a Constructed Wetland Treatment System. The excess flow is directed into a high-flow bypass channel which is discussed below.

Conveyance Channel E1, E2, and E3. E1 commences at the confluence between channels C and D and conveys water in a constructed channel along the alignment of the existing site access road. Channel E2 continues the conveyance of water from Channel E1. Conveyance channel E3 has a slope grade of 20%, and is required to transition high velocity flow to a Stilling Basin and the Primary Head Pond which would both be located at the present location of the western edge of the WSP shoreline.

- **High Flow Bypass Channel.** The High Flow Bypass Channel conveys flows from the Primary and Secondary Head Ponds through High Flow Control Structures around the Constructed Wetland Treatment System (CWTS) to lower Minto Creek. Flows that are diverted around the wetland are those that are in excess of the design flow rate for the CWTS or which enter the channel via the Tailings Diversion Ditch (SRK 2016 and Contango 2016).
- **Stilling Basin.** Downslope of the E3 channel high velocity water is received by a Stilling Basin which is designed to dissipate energy and contain the development of a hydraulic jump within the protected stilling basin surface. Water passes from the stilling basin onto the Primary Head Pond.
- **Primary and Secondary Head Ponds.** The Primary Head Pond moderates turbulent flows that exit the Stilling Basin before water is directed into the Secondary Head Pond or the High Flow Bypass Channel by flow control structures on the south side of each head pond. Water detained in the Secondary Head Pond is conveyed into the CWTS or into the High Flow Bypass Channel by a second set of flow control structures. The dual head pond system is designed to step down the flow rate discharging the Channel E3 to essentially separate the wetland design flow from the remainder of the water discharging the site. A design layout for the Primary and Secondary head ponds are illustrated in the Minto Creek Constructed Wetland: Physical Infrastructure Preliminary Design report (SRK 2016).

3.2 Design Criteria

The following design criteria was utilized for the preliminary closure design:

Hydrology and Hydraulics. All six closure conveyance channels are designed and protected for flows up to a 24-hour, 1:200 year return period event. The conveyance channels are able to convey PMP without overtopping, with exception of Channel E2, which is topographically confined at the valley bottom. During a PMP event, riprap protection may be displaced and erosion will occur.

Contributing catchment areas to each channel are described in Appendix B. Normal depth estimations were used to assess the channel hydraulics and geometry. A HEC-HMS model allowed assessment of a range of peak return period flows from 1:2 year, 1:10 to 1:200 year, and PMF events.

Channel Alignment. Conveyance channel alignments were selected based on four main criteria:

- Conveyance of runoff generated from catchment areas,
- Minimization of channel slopes and excavation volumes (while maintaining alignments that are robust against excess flows and negative effects of long term thaw consolidation of foundation materials),
- Utilization of pit lakes that establish in the Main Pit and Area 2 Pit to dissipate energy and settle sediments, and
- Ultimately conveying site flows to the Minto Creek channel upstream of the W3 monitoring station downstream of all mine disturbances.

Concept of Low Maintenance. Closure conveyance channels must be designed in a manner that their constructed features are robust and durable. Key design criteria should consider the following:

- Rock riprap erosion protection,
- Robust geometry that reduces the risk of overtopping and erosion,
- Allowance for future climate change conditions and discharge requirements, and
- Utilization of pit lakes that establish in the Main Pit and Area 2 Pit for mixing, energy dissipation, and sediment deposition.

Typical Channel Geometry. All closure conveyance channels are designed with a typical geometry that reflects the size and capability of the heavy equipment used on site. Excluding Channel E1 and E3, all channels have a typical geometry, are designed to have a base width of 7 m and 2:1 side slopes, and a minimum freeboard of 0.5 m. Channel depths are variable due to channel grade and riprap sizes. Excavated depths are reported in the summary tables provided in the drawing package (Appendix A).

Riprap Protection and Seepage Management. All closure conveyance channels are designed to be lined with rock riprap for erosion protection. Each channel is divided into segments that relate to a typical riprap classification. Riprap specifications and summary tables are provided in the drawing package (Appendix A). Evaluation of the suitability for using vegetation as stand-alone protection for shallow gradient section will be considered at a later stage of design.

Conveyance E2 includes an excavated pilot channel in the base of the main conveyance channel. The pilot channel is designed to convey 1:2 year peak flows. Pilot channel geometry is 1 m wide and 1 m deep with 2:1 side slopes.

Seepage loss through conveyance channel E2 is considered to pose a minimal risk to the environment. At later stages of closure design, a geomembrane or low conductivity layer may be added to the design to minimize seepage loss in segments of the conveyance channels if further analysis determines that minimizing seepage to the maximum extent possible is necessary.

Furthermore, sediment migration and erosion of the base material beneath the rock riprap protection does not warrant a geotextile for the alignments proposed at this stage of design. A geotextile is not factored in because the excavated material from which the channel alignments are constructed consists of either heavily compacted fills from existing haul roads or coarse rock fills generated during mine development. However, during later stages of design, if alignments are altered and the foundation materials change, the channels may require a geotextile separation layer between the riprap and the excavated foundation.

Stilling Basin. This structure is designed and protected to convey up to the PMF and has a maximum slope of 20% followed by a slope of 0.5%. This abrupt slope change is anticipated to produce a hydraulic jump under design flows that allows energy to dissipate. To improve the energy reduction, the channel width is increased from 7 to 20 m.

Primary and Secondary Head Ponds. A design criteria developed for the management of the passive treatment wetlands is to separate up to 3000 m³/day of water from the discharge of E3 and the Stilling Basin and convey it into the wetlands (Contango 2016). To moderate the flows to the CWTS and to direct excess flows to the High Flow Bypass Channel a sequence of a Primary and a Secondary Head Pond with inlet flow control structures and outlet overflow structures are required.

High Flow Bypass Channel. The second component to the CWTS flow conveyance system is required to bypass the flows that exceed the design flow capacity of the CWTS. The High Flow Bypass Channel is designed to convey excess flow from the two head ponds around the wetland system, as well as to keep the discharge from the Tailings Diversion Ditch separate from the wetlands and route that water to lower Minto Creek. Downstream, wetland passive treatment discharge flows will join with the bypass flow and enter Minto Creek.

4 Methodology

4.1 Design Flow Estimates

Conveyance channel design flows were determined based on a site-wide hydrology and climate change review that was prepared by SRK, as summarized in Section 2.1. The methodology used to analyze the hydrology and climate data is detailed in technical reports provided in Appendix B through Appendix D.

4.2 Conveyance Channel Typical Geometry and Erosion Protection

The hydraulic analysis and sizing of channels were determined using the Manning's Equation with steady state normal depth. This procedure is considered an iterative process between water

depth, Manning's roughness, and riprap sizes. Most of closure conveyance channels have a base width of 7 m and side slopes of 2H:1V.

Riprap sizing and Manning's roughness values were derived through model iterations. The Manning's equation was evaluated using initial roughness values, and the results were extracted at each channel-slope representative interval. For each interval, the D_{50} of the riprap was calculated based on the velocity in the channel, and the corresponding Manning's roughness value was calculated based on the riprap sizing. This process was repeated until similar n values were obtained between model iterations.

4.2.1 Riprap Calculations

Closure Conveyance Channels

Riprap sizing for the closure conveyance channels was estimated using three expressions: Isbash (USACE 1991), Robinson et al. (1998), and Khan and Ahmad (2011). To be conservative, the maximum of the three estimates was used in the conveyance channel design.

Equation 2 presents the Isbash expression.

$$D_{50} = \frac{V^2}{C^2 2g \left(\frac{\gamma_s - \gamma_w}{\gamma_w} \right)} \quad \text{Eq. [2]}$$

Where V is the average velocity (ft/s), g is gravitational acceleration (ft/s²), γ_s is the unit weight of riprap (lb/ft³), γ_w is the unit weight of water (lb/ft³), D_{50} is the median riprap size (ft), and C is the Isbach coefficient. The Isbach coefficient was set to 1.2 for low turbulence or bank protection.

Equations 3 and 4 present the Robinson (1998) expressions, which are based on the channel slope.

$$D_{50} = \left(\frac{Q}{9.76 \times 10^{-7} * S^{-1.50}} \right)^{\frac{1}{1.89}} \quad S < 0.10 \quad \text{Eq. [3]}$$

$$D_{50} = \left(\frac{Q}{8.07 \times 10^{-6} * S^{-0.58}} \right)^{\frac{1}{1.89}} \quad 0.10 \leq S \leq 0.40 \quad \text{Eq. [4]}$$

Where Q is the unit peak flow rate (m³/s/m), D_{50} is the median riprap size (m), and S is the slope (m/m).

Equation 5 presents the Khan and Ahmad (2011) expression.

$$D_{50} = 0.66 \times t^{0.58} \times S^{0.22} \times C_u^{-0.45} \times Q_f^{0.22} \quad \text{Eq. [5]}$$

Where t is the riprap thickness (m), S is the channel slope (m/m), C_u is the coefficient of uniformity, and Q_f is the critical unit discharge (m³/s/m).

Stilling Basin and Head Pond

Because the Stilling Basin and the Head Pond are designed for a PMF, the riprap sizes were defined beyond the typical use for some of the riprap expressions. Therefore, the above three expressions were complemented with Wittler and Abt, Mishra, and LaGasse et al. (Abt et al. 2013), which suggests the expressions are more representative of larger sized riprap.

Because of the result variability, the riprap selected was based on the average of these all six expressions (i.e. Isbash, Robinson et al., Khan and Ahmad, Wittler and Abt, Mishra, and LaGasse et al.), where the minimum and maximum values were removed from the average.

4.2.2 Manning's Roughness Estimation

Given a riprap size estimate, a Manning's roughness value (n) was then calculated based on three relationships by Strickler, Anderson, and Abt et al. (1988). The average n value obtained from the three expressions was selected. A smaller n value corresponds to a higher velocity and lower flow depth and vice versa; the average provides a conservative velocity and depth for the design.

Equation 6 presents the Strickler expression.

$$n = 0.0385K_s^{1/6} \quad \text{Eq. [6]}$$

Where n is the Manning's roughness value, and K_s is the particle diameter of the largest 15% of the riprap grain size distribution (ft).

Equation 7 presents the Abt et al. (1988) expression.

$$n = 0.0456(D_{50} \times S)^{0.159} \quad \text{Eq. [7]}$$

Where n is the Manning's roughness value, S is the channel slope (ft/ft), and D_{50} is the average riprap diameter (inches).

Equation 8 presents the Anderson expression.

$$n = 0.0395D_{50}^{1/6} \quad \text{Eq. [8]}$$

Where n is the Manning's roughness value, and D_{50} is the average riprap diameter (ft).

4.2.3 Riprap Classification and Gradation for Conveyance Channels

The riprap classifications (Table 1) were developed based on MOT BC (2006) to follow the design rationale described in this section for the closure channel segments. As stated before, the conveyance channels are composed of channel segments that have a typical profile, slope, and velocity profile. Each segment was assigned a riprap class and a layer thickness. The layer thickness is an aggregate of rock diameter types. Details pertaining to the riprap specifications for each segment are provided in the drawing package (Appendix A).

Table 1: Riprap Class Gradation

Class of Riprap [kg]	Nominal Thickness of Riprap [mm]	Rock Gradation Percentage Larger than Given Rock Mass [kg]			Rock Gradation Percentage Smaller than Given Rock Diameter [mm]				
		85%	50%	15%	D ₁₅	D ₃₀	D ₅₀	D ₈₅	D ₁₀₀
10	350	1	10	30	90	140	200	280	300
25	450	2.5	25	75	130	200	300	380	450
100	700	10	100	300	200	300	450	610	680
250	1000	25	250	750	270	400	600	820	900
1000	1500	100	1000	3000	420	670	1000	1300	1500

5 Closure Conveyance Channel Design

This section summarizes the closure conveyance channel design parameters. Closure conveyance channels have a typical side slope and base width geometry. Channel depths are variable and related to the depth of water being conveyed, specification tables for the channel geometry, flow depths and riprap are provided in Appendix A. All conveyance channel alignments are selected to avoid sharp bends to minimize the risk of scour and erosion to minimize long term maintenance requirements. Additional design elements that are specific to each channel are provided in the following sections and in the drawing package included in Appendix A.

The following designs are prepared as interim closure conveyance channel designs which are based on the as-built configuration of the November 2015 surface. Channel alignment designs will require review based on future changes to mining and closure plans. Final design review and refinement is required to assess channel grade and alignment based on the final mining closure plan and the as-built 3-dimensional ground surface after all mining-related disturbance is complete.

5.1 Channel A

The closure design concept of Channel A is to collect and convey surface water from the W15 tributary to the Main Pit. Included in the drawing package (Appendix A) for the A channel are alignment plans, profiles and typical cross-sections (Drawings CC-01 and CC-02). Table 2 summarizes the closure conveyance hydraulic design for Channel A.

Table 2: Design Summary for Closure Conveyance Channel A

Segment ID	Length [m]	Slope [%]	Flow [m ³ /s]	Water Depth 1: 200 yrs. [m]	Channel Depth [m]	Riprap Class (kg)
1	40	1.0	11.3	0.70	1.50	10
2	89	10.0	11.3	0.50	1.00	100
3	70	8.0	11.3	0.50	1.00	25
4	117	13.9	11.3	0.40	1.00	100
5	88	17.0	11.3	0.40	1.00	100
6	21	27.0	11.3	0.40	1.00	100

5.1.1 W15 Tributary Intake

Surface water from the W15 tributary is designed to enter Channel A through an intake transition section. This section will be designed to a detail level upon the completion of final mine closure designs or integrated into the potential design of a wetland area in the W15 pond and tributary area.

5.2 Channel B

The closure design concept for Channel B is to collect and convey surface water from the W35A tributary and the Airport Road Ditch to the Area 2 Stage 3 Pit. This conveyance channel will utilize the operational overflow spillway for the Tailings Diversion Ditch intake structure that is proposed by SRK (2014) in the Upgraded Tailings Diversion Ditch Design. Included in this closure design are drawings for the Channel B alignment plans, profiles and typical cross-sections in Drawings CC1 and CC3 (Appendix A). Table 3 summarizes the closure conveyance hydraulic design for the Channel B.

Table 3: Design Summary for Closure Conveyance Channel B

Segment ID	Length [m]	Slope [%]	Flow [m ³ /s]	Water Depth 1: 200 yrs. [m]	Channel Depth [m]	Riprap Class (kg)
1	97	1.0	8.1	0.6	1.2	10
2	70	1.8	8.1	0.5	1.2	10

5.2.1 W35A Tributary and South Diversion Ditch Intake

Surface water from the W35A tributary and the South Diversion Ditch is designed to enter Channel B through an intake transition section. This section will be designed to a detail level upon the completion of final closure designs. The transition section should include rock riprap erosion protection and compacted earth berms that direct flow from the W35A tributary and the South Diversion Ditch into the conveyance channel.

5.2.2 Tailings Diversion Ditch Pipe Deactivation

Included in the design for the Upgraded Tailings Diversion Ditch (SRK 2014) is a buried HDPE pipe that conveys surface water from the W35A tributary and South Diversion Ditch into the Tailings Diversion Ditch. The closure conveyance channel design will plug and backfill the entrance to the HDPE pipe to reroute surface flow to the Area 2 Stage 3 Pit.

5.2.3 Spillway into Area 2 Stage 3 Pit

The location of the swale crossing utilizes the underground portal access road spillway proposed in the Upgraded Tailings Diversion Ditch Design (SRK 2014). To maintain light vehicle access for post closure activities, a swale crossing is incorporated into the channel crossing. Downstream of the swale crossing, Channel B will not be excavated or protected with rock riprap. Conveyed flow

will exit the erosion protected spillway swale and naturally erode a channel into the Area 2 Stage 3 Pit. At later stages of closure design, channel alignments can be optimized to minimize the extent of natural erosion. The sediment that is eroded from this channel will be transported to and settled out into the Area 2 Stage 3 Pit.

5.3 Channel C

The closure design concept for Channel C is to convey discharge water from the Main Pit and discharge water from the Area 2 Pit via Channel D. Transported water in Channel C that discharges into Channel E and the High Flow Bypass Channel that ultimately carries the water to Minto Creek. Included in the closure design are drawings for Channel C alignment plans, profiles, and typical cross-sections (Drawing CC-04, Appendix A). Table 4 summarizes the closure conveyance hydraulic design for Channel C.

Table 4: Design Summary for Closure Conveyance Channel C

Segment ID	Length [m]	Slope [%]	Flow [m ³ /s]	Water Depth 1: 200 years [m]	Channel Depth [m]	Riprap Class [kg]
1	165	1.1	15.3	0.8	1.7	10

5.3.1 Confluence Design Channel E, D, and C

Closure conveyance channels D and C merge together upstream of Channel E, approximately 0+357 m downstream of the Main Pit. This confluence location was selected due to the mild convergence profile for the two channels where the slope for Channel C is 1.1% and slope for Channel D is 8.9%. At the confluence a hydraulic jump will occur that results in an increase in design flow depth from 0.4 m to 0.9 m. Riprap for Channel D should continue for 5 m downstream of the convergence to protect against the additional turbulence resulting from the hydraulic jump (Drawing CC-04, Appendix A).

A transition section for Channel D is required at the confluence to account for the backwater effect that will occur in the channel due to the flow profile misalignment between channels D, C, and E. The berms for Channel D will require a transition reach, increasing its berm height to account for the flow depth increase (Drawing CC-04, Appendix A).

5.3.2 Main Pit Discharge Channel Transition Section

At a later closure design stage, the transition section for discharge water from the Main Pit entering into Channel C will require detailed design. The future design must provide a reinforced entrance to the channel.

5.3.3 Channel C Access Road

Designed to parallel Channel C is a 4 m wide light vehicle access road. This road will provide post-closure access for monitoring and maintenance of the conveyance channels. The road part

of a network of post-closure access roads across the site. The traffic surface of the access road is sloped towards the conveyance channel for drainage and to minimize excavation.

5.4 Channel D

The closure design concept for Channel D is to convey discharge water from the Area 2 Pit to the confluence of Channel C. Included in this closure design are drawings for the Channel D alignment plans, profiles, and typical cross-sections (Drawing CC-05, Appendix A). Table 5 summarizes the closure conveyance hydraulic design for Channel D.

Table 5: Design Summary for Closure Conveyance Channel D

Segment ID	Length [m]	Slope [%]	Flow [m ³ /s]	Water Depth 1: 200 yrs. [m]	Channel Depth [m]	Riprap Class [kg]
1	140	1.0	9.4	0.7	1.3	10
2	81	7.1	9.4	0.4	1.0	25
3	76	9.8	9.4	0.4	1.0	25

5.4.1 Area 2 Pit Discharge Transition Section

Discharge water from the Area 2 Pit enters into Channel D through a transition section. Details and design specifications should be revised once mining-related activities in the pit are completed and final plans for grading the area are in progress. Upon completion of a detailed design and foundation assessment the transition section will provide an inlet to the conveyance channel that cannot be bypassed. A flow contraction transition structure constructed from overburden backfill and coarse oversize rock riprap is recommended for consideration to direct the pit discharge into Channel D. Drawing CC-05 (Appendix A) illustrates the transition section.

5.5 Channel E

Conveyance Channel E is composed of three sequential subsections: E1, E2, and E3. Channel E1 starts at the confluence of channels C and D and conveys flows originating from the Main Pit and from the Area 2 Pit along the existing access road. As illustrated in Appendix A, Channel E1 transitions to Channel E2 that transitions to the spillway channel section, E3, which discharges into the present location of the Water Storage Pond footprint.

The closure design concept for the Channel E system is to continue conveying water from the Minto site to lower Minto Creek, via a combination of the CWTS and the High Flow Bypass Channel (depending on the magnitude of flows). The upstream confluence transition between channels C and D requires the design of a transition section because of the development of turbulent channel hydraulics that will occur at the confluence.

The Channel E alignment is designed to overlay the current mine access road. A light vehicle access road parallels the closure conveyance channel to the south. The existing road surface was chosen for construction of a channel because the roadway has undergone traffic compaction

over the LOM and is expected to experience minimal long-term settlement and minimal seepage loss compared to a channel constructed on undisturbed ground.

Channel E1 and E2 are designed to include a pilot channel excavated into the base of the main channel. The pilot channel is designed to convey up to the 1:10 year return period peak flows. Flows in excess of the 1:10 year discharge will overtop into the main conveyance channel. Included in this closure design are drawings for the E channel are alignment plans, profiles, and typical cross-sections (Appendix A). Table 6 summarizes the closure channel's hydraulic design for the Channel E system.

Table 6: Design Summary for Closure Conveyance Channel E

Segment ID	Length [m]	Slope [%]	Flow [m ³ /s]	Water Depth 1: 200 yrs. [m]	Channel Depth [m]	Riprap Class (kg)
1	279	1.1	26.9	1.0	2.00	10
2	38	1.9	26.9	1.7	2.00	25
3	222	7.0	26.9	1.4	2.00	100
4	98	1.4	26.9	1.8	2.00	10
5	163	6.0	26.9	1.5	2.00	100
6	104	4.1	26.9	1.6	2.00	100
7	33	7.6	26.9	1.4	2.00	100
8	47	5.1	26.9	1.2 (1)	2.00	100
9	150	20.0	26.9	1.1 (1)	1.30	1000
10	20	0.5	26.9	1 (1)	1.20	1000
11	20	0.5	26.9	1.5 (1)	1.60	25

Note:

(1) Refers to a critical water depth for a PMF event

5.5.1 E1 and E2 Pilot Channel and Geomembrane Seepage Management

The current closure design considers the construction of the channel on the existing access road, which is heavily compacted and resistant to settlement and to channel seepage loss.

At future stages of closure design, the need for seepage management along Channel E2 should be evaluated and, if found necessary, may require incorporation of design details to address the need to further limit seepage losses from the channel. This potential additional design requirement could be addressed through lining the channel or components of the channel with low conductivity geomembranes. At this stage of the design the compacted road material of the existing site access road is accepted as sufficiently low permeability to adequately limit seepage losses.

Channels E1 and E2 will include a pilot channel that is excavated into the base of the main channel and partially into the compacted roadway. The geometry of the pilot channel is 1.0 m

wide base, 1.0 m deep, and 2H:1V side slopes and is designed to convey up to the 1:10 year return period peak flows. Flows in excess of the 1:10 will flood into the main conveyance channel.

5.5.2 E3 Channel

Channel E3 is designed without the pilot channel required by E1 and E2. Channel E3 is designed as a high velocity conveyance channel that descends from channel E2 to the Stilling Basin. Channel E3 terminates into the Stilling Basin and Head Pond. The channel slope is 20 % which requires 1000 kg Class riprap for erosion protection.

5.6 Stilling Basin

Downslope of the E3 channel is the Stilling Basin which is designed to contain the development of a hydraulic jump within the protected stilling basin surface. The Stilling Basin geometry consists of a 7 to 20 m wide spreading transition stilling basin channel with 2H:1V side slopes constructed from rock riprap. Outflow from the Stilling Basin transitions into the Primary Head Pond which has a surface elevation of 715 masl.

5.7 High Flow Bypass Channel

The High Flow Bypass Channel conveys flows (Table 7) from the Head Pond through a 40 m wide and 0.5 m deep spillway and around the passive treatment wetland area. Flows that are diverted around the CWTS are those that are in excess of the design flow rate that can be managed by the wetlands (SRK 2016 and Contango 2016).

Table 7: Design Summary for Closure Conveyance High Flow Bypass Channel

Segment ID	Length [m]	Slope [%]	Flow [m ³ /s]	Water Depth 1: 200 yrs. [m]	Channel Depth [m]	Riprap Class [kg]
1	29	0	28.8	1.2	2.4	25
2	63	5.0	28.8	0.5	2.0	25
3	63	1.8	28.8	1.0	2.0	25
4	92	3.3	28.8	1.0	2.0	25
5	331	3.1	28.8	1.0	2.0	25

5.8 Primary and Secondary Head Ponds

The Primary Head Pond moderates turbulent flows that exit the Stilling Basin before water is directed into the Secondary Head Pond or the High Flow Bypass Channel by two flow control structures (Details presented in CW-03). Water detained in the Secondary Head Pond is conveyed into the CWTS or into the High Flow Bypass Channel by a second set of flow control structures.

The dual head pond system is designed to step down the flow rate discharging the E Conveyance Channel to essentially separate the wetland design flow from excess flows.

Design details for the CWTS and the head pond flow control structures can be found in *Minto Creek Constructed Wetland: Physical Infrastructure Preliminary Design* SRK 2016.

6 Integrating Vegetation Erosion Protection

This section summarizes how the integration of vegetation into channel erosion protection is to be incorporated.

It is proposed that live vegetation be utilized to assist with channel stabilization and erosion control of disturbed soil within the conveyance systems. Biotechnical techniques improve soil reinforcement of disturbed slopes and regraded areas and ultimately assist in establishing vegetation, riparian zones, and develop soils. The use of these techniques do not replace the need for rock riprap site wide, but can complement and improve channel stabilization designs and may prove to be effective as stand-alone protection where channel grades are shallow.

The vegetation proposed for channel stabilization and erosion control focus on the use of coarse woody, grass and legume, and wetland species of vegetation. Techniques for channel stabilization are recommended to be a combination of methodologies as listed in Table 8. Further details on the selection of vegetation species and biotechnical techniques are included with this report in Appendix E.

Table 8: Selected Biotechnical Techniques based on Landform

Biotechnical Technique Name	Disturbed and Excavated Slopes	Riparian Vegetation Development	Channel Erosion Protection
Rolled Erosion Control Products	✓		
Riprap Armouring	✓		✓
Slope Drains	✓	✓	
Hydroseeding	✓	✓	
Live Staking	✓	✓	✓
Brush Layering	✓	✓	✓
Wattle (Live Fascine)	✓	✓	
Surface Roughening	✓	✓	
Slope Benching	✓		
Coir/Straw Rolls with Brush Layers	✓	✓	
Brush Mattress	✓	✓	
Live Siltation		✓	✓
Willow Post and Pole	✓	✓	✓
Vegetated MSE	✓	✓	✓
Vegetated Riprap	✓	✓	✓

7 Information Required to Advance the Channel Design

To further develop the closure conveyance channel design towards a final closure design plan, the following data requirements and project developments are required:

- The final post-mining as-built surfaces (such as as-built waste rock and pit surfaces) will be required to update and optimize the conveyance channel design.
- Review site wide closure planning and closure designs for other site components. This will help determine design gaps or redundancies in the closure conveyance channel design and identify opportunities for optimization and integration.
- In conjunction with review of site-wide closure designs, surficial drainage features from adjacent areas will need to be incorporated into the conveyance system. Designed drainage features include elements in the final cover designs, landform grading on waste rock dumps and tailings covers, and mine elements (e.g. haul roads, pit shells, and the underground portal).
- Design elements for a passive treatment wetland at the W15 tributary area and the WSP will need to be included. The closure conveyance design will require final decisions on wetland designs to finalize the position of channels and energy dissipation structures.
- Include an as built design of the Tailings Diversion Ditch upon its completion to finalize the design of the High Flow Bypass Channel and the wetland infrastructure.
- Final post closure road layout design is required for all access roads that are to be maintained on the mine site. This road network will depict where and how the final design of channel crossings will be positioned and aligned.
- It is expected that the channels will have minimum seepage loss. An assessment is recommended to determine the sensitivity of the downgradient waste rock and other materials that may come in contact with channel seepage. The seepage assessment should include how much seepage loss is expected from the channels, whether (and to what degree) the seepage will come in contact with waste rock, and whether the effects are material.
- At future stages of closure design, details to the specific hydraulic design of the Main and Area 2 open pits discharge sections and the energy dissipation aprons will be developed.

This report, "Closure Water Conveyance System Design Update Report, Minto Mine", was prepared by

Original Signed By

Stuart McPhee, EIT

Original Signed By

Victor Muñoz S., MEng, PEng.

and reviewed by

Original Signed By

Dylan McGregor, MAsc, PGeo

All data used as source material plus the text, tables, figures, and attachments of this document have been reviewed and prepared in accordance with generally accepted professional engineering and environmental practices.

Disclaimer—SRK Consulting (Canada) Inc. has prepared this document for Minto Explorations Ltd.. Any use or decisions by which a third party makes of this document are the responsibility of such third parties. In no circumstance does SRK accept any consequential liability arising from commercial decisions or actions resulting from the use of this report by a third party.

The opinions expressed in this report have been based on the information available to SRK at the time of preparation. SRK has exercised all due care in reviewing information supplied by others for use on this project. Whilst SRK has compared key supplied data with expected values, the accuracy of the results and conclusions from the review are entirely reliant on the accuracy and completeness of the supplied data. SRK does not accept responsibility for any errors or omissions in the supplied information, except to the extent that SRK was hired to verify the data.

8 References

- Abt S, Wittler R, Ruff J, and Khattak M. 1988. Resistance fo flow over riprap in steep channels. *Water Resources Bulletin*, 1193-1200.
- Abt S, Thornton C, Scholl B, and Bender T. 2013. Evaluation of overtopping riprap design relationships. *Journal of the american water resources association*, Vol N°49, N°4, Pp 923-937.
- Contango Strategies Ltd. 2016. Minto Mine Reclamation and Closure Plan – Preliminary Design Report for Treatment Wetland. Saskatoon, SK, Canada. July.
- Construction and Maintenance Branch - Ministry of Transportation. 2006. 2006 Design Built Standard Specifications for Highway Construction. BC.
- HEC-HMS. 2013. Hydrologic Modeling System Version 4.0. Developed for the U.S. Army Corps of Engineers.
- [IPCC] Intergovernmental Panel on Climate Change. 2007. Climate Change 2007: Synthesis Report. Contribution of Working Groups I, II and III to the Fourth Assessment Report of the Intergovernmental Panel on Climate Change [Core Writing Team, Pachauri, R.K and Reisinger, A. (eds.)]. IPCC, Geneva, Switzerland, 104 pp.
- Khan D, and Ahmad Z. 2011. Stabilization of Angular-Shaped Riprap under Overtopping Flows. *World Academy of Science, Engineering and Technology*, Vol N°5, N°11, 775-779.
- [MOTBC] BC Ministry of Transportation. 2006.
- Robinson K, Rice C, and Kadavy K. 1998. Design of Rock Chutes. *American Society of Agricultural Engineers*, Vol. 41(3): 621-626.
- SRK Consulting. 2014. Upgraded Tailings Diversion Ditch Design. Vancouver, BC, Canada. September.
- SRK Consulting. 2016. Minto Creek Constructed Wetland: Physical Infrastructure Preliminary Design. Vancouver, BC, Canada. August.
- USACE, 1991. Hydraulic Design of Flood Control Channels, Engineer Manual, No. 1110-2-1601.

Appendix A – Conveyance System Drawings

Engineering Drawings for the Closure Conveyance Design, Minto Mine, Yukon, Canada

ACTIVE DRAWING STATUS

DWG NUMBER	DRAWING TITLE	REVISION	DATE	STATUS
CC-00	Engineering Drawings for the Closure Conveyance Design, Minto Mine, Yukon, Canada	A	July 27, 2016	Issued For Review
CC-01	General Arrangement	A	July 27, 2016	Issued For Review
CC-02	A Conveyance Channel	A	July 27, 2016	Issued For Review
CC-03	B Conveyance Channel	A	July 27, 2016	Issued For Review
CC-04	C Conveyance Channel	A	July 27, 2016	Issued For Review
CC-05	D Conveyance Channel	A	July 27, 2016	Issued For Review
CC-06	E1 Conveyance Channel	A	July 27, 2016	Issued For Review
CC-07	E2 Conveyance Channel	A	July 27, 2016	Issued For Review
CC-08	E3 Conveyance Channel	A	July 27, 2016	Issued For Review
CC-09	High Flow By-Pass Channel	A	July 27, 2016	Issued For Review



NOT FOR CONSTRUCTION



PROJECT NO: 1CM002.042
Revision A - Issued for Review
July 27, 2016
Drawing CC-00

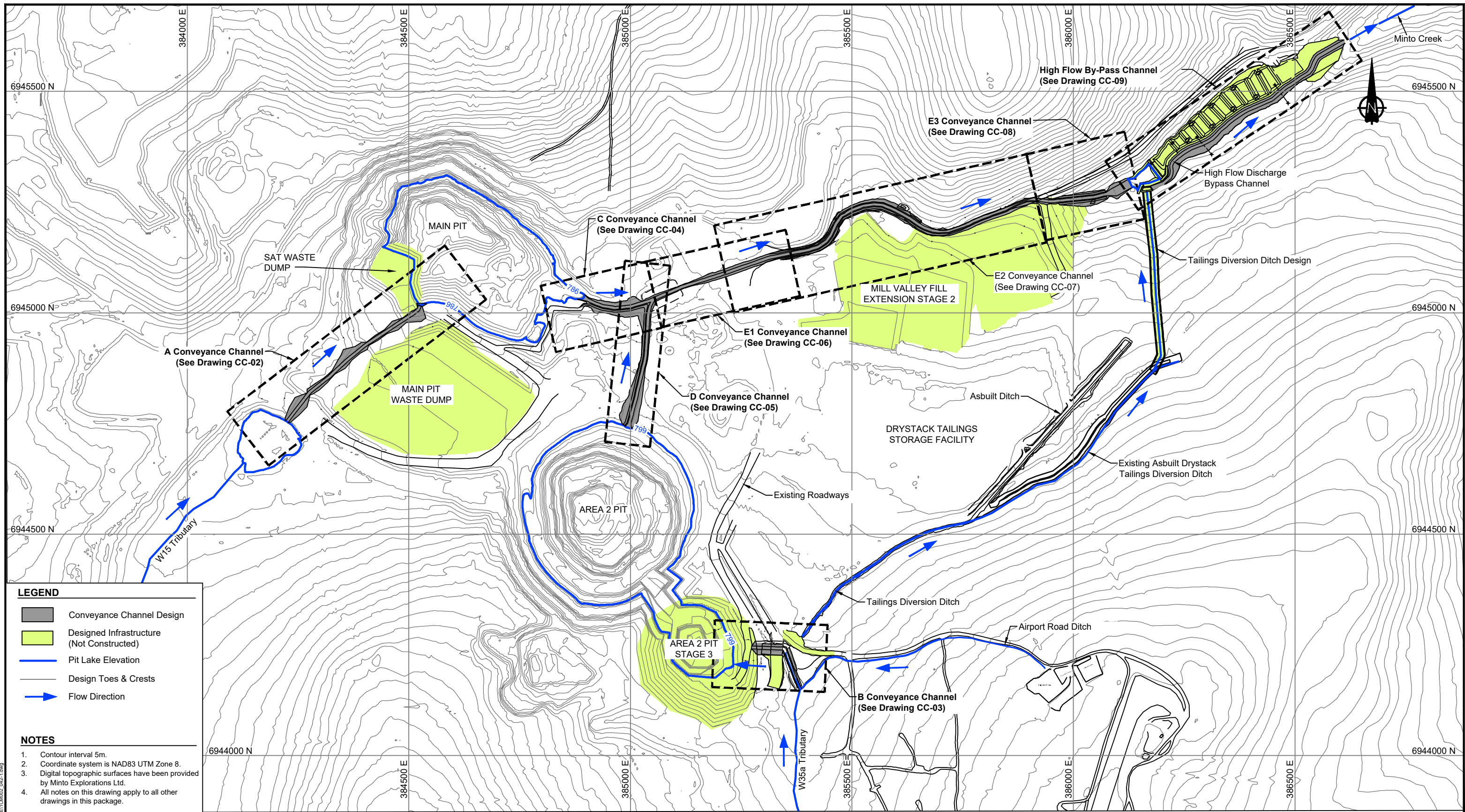

NOT FOR CONSTRUCTION

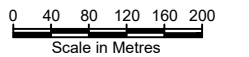

DRAWING NO.	DRAWING TITLE	DRAWING NO.	DRAWING TITLE	NO.	DESCRIPTION	CHK'D	APP'D	DATE
				A	Issued for Review	SM	—	15Jul16
					REVISIONS			

This drawing is uncontrolled when printed unless stamped and signed with original ink and recorded on a Distribution Register.

PROFESSIONAL ENGINEERS STAMP

srk consulting

DESIGN:	SM	DRAWN:	NV	REVIEWED:	SM
CHECKED:	SM	APPROVED:	DM	DATE:	July 2016

FILE NAME: 1CM002_042-1.dwg

capstone
MINTO MINE
OPERATED BY MINTO EXPLORATIONS LTD.

MINTO EXPLORATIONS Ltd.

SRK JOB NO.: 1CM002.042

Closure Conveyance Design

DRAWING TITLE:
General Arrangement

DRAWING NO. CC-01	SHEET 2 OF 10	REVISION NO. A
-----------------------------	------------------	--------------------------

C:\MDS\CLIENTS\SRK\CON\MINTO\CLOSURE\1CM002_042_1.dwg

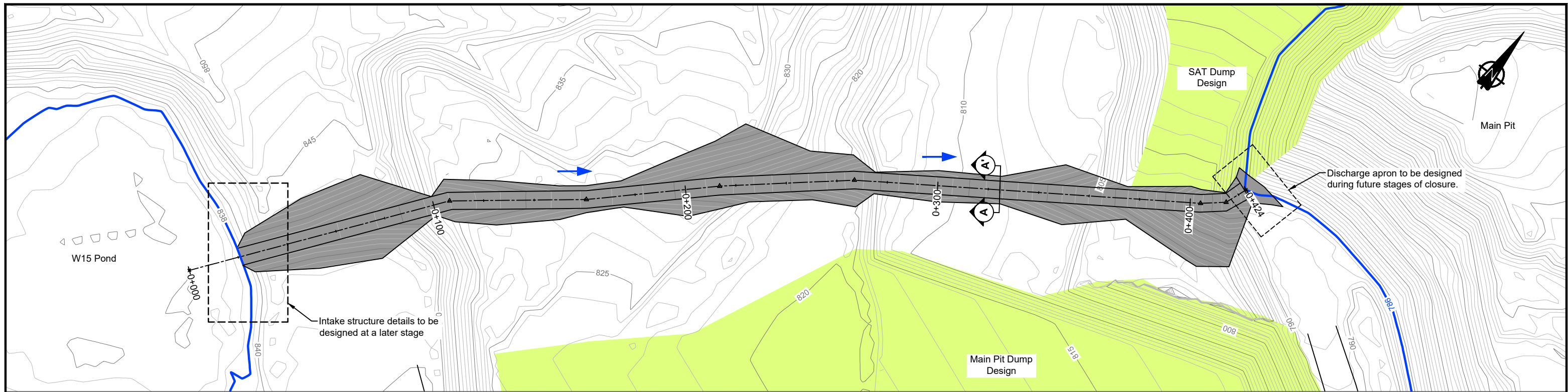

**PLAN VIEW
A CONVEYANCE CHANNEL**

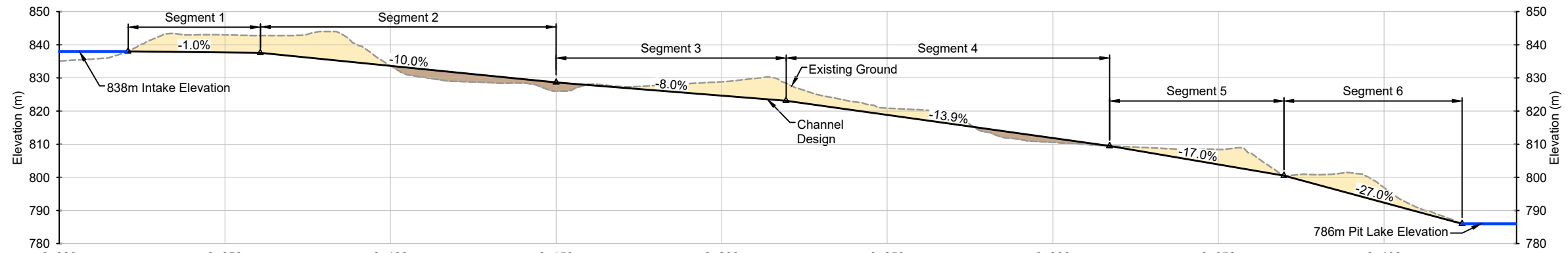
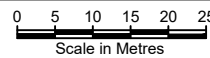

**PROFILE
A CONVEYANCE CHANNEL**

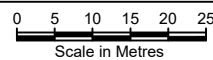

LEGEND

- Conveyance Channel Design
- Channel Fill
- Channel Excavation
- Designed Infrastructure (Not Constructed)
- Pit Lake Elevation
- Design Toes & Crests
- Flow Direction

NOTES

1. Contour interval 1m.
2. Digital topographic surfaces have been provided by Minto Explorations Ltd.
3. Topographic surfaces are comprised of existing and designed surfaces.
4. Constructed channel specifications are provided in the specifications table as per each channel segment.
5. Rip Rap classification gradation tables are provided in Drawing CC-06.
6. Future mining activities may alter the topography of the channel alignment. SRK recommends that at future stages of closure design channel alignment and grades be re-assessed.
7. All notes on this drawing apply to all other drawings in this package

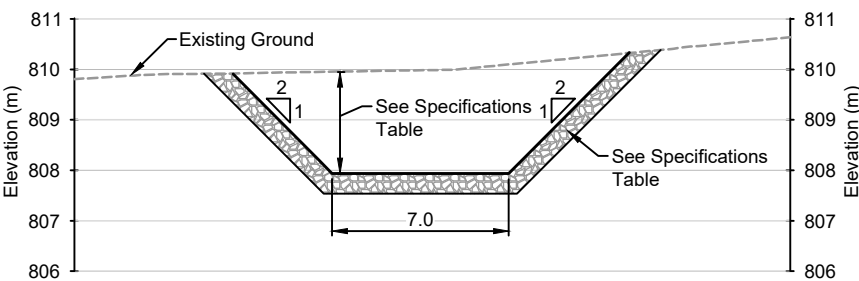

SECTION A
Horizontal Scale in Metres
Vertical Exaggeration 2X

CHANNEL A SPECIFICATIONS:

Segment	Length (m)	Slope (%)	Channel Depth (m)	Water Depth for 1:200 yrs (m)	Rip-rap Class (kg)	Rip-rap Thickness (mm)
1	40	-1.0	1.5	0.70	10	350
2	90	-10.0	1.0	0.50	100	700
3	70	-8.0	1.0	0.50	25	450
4	97	-13.9	1.0	0.40	100	700
5	53	-17.0	1.0	0.40	100	700
6	54	-27.0	1.0	0.40	100	700

NOT FOR CONSTRUCTION

								Closure Conveyance Design DRAWING TITLE:		
DESIGN: SM DRAWN: NV REVIEWED: SM CHECKED: SM APPROVED: DM DATE: July 2016				MINTO EXPLORATIONS Ltd.				A Conveyance Channel		
FILE NAME: 1CM002_042-1.dwg				SRK JOB NO.: 1CM002.042				DRAWING NO. CC-02 SHEET 3 OF 10 REVISION NO. A		
DRAWING NO.		DRAWING TITLE		DRAWING NO.		DRAWING TITLE		A Issued for Review SM - 15Jul16 NO. DESCRIPTION CHK'D APP'D DATE		
REFERENCE DRAWINGS				REVISIONS				PROFESSIONAL ENGINEERS STAMP		

C:\MDC\CLIENTS\SRK\2016\MINTO CLOSURE\DRAWING_042-1.dwg

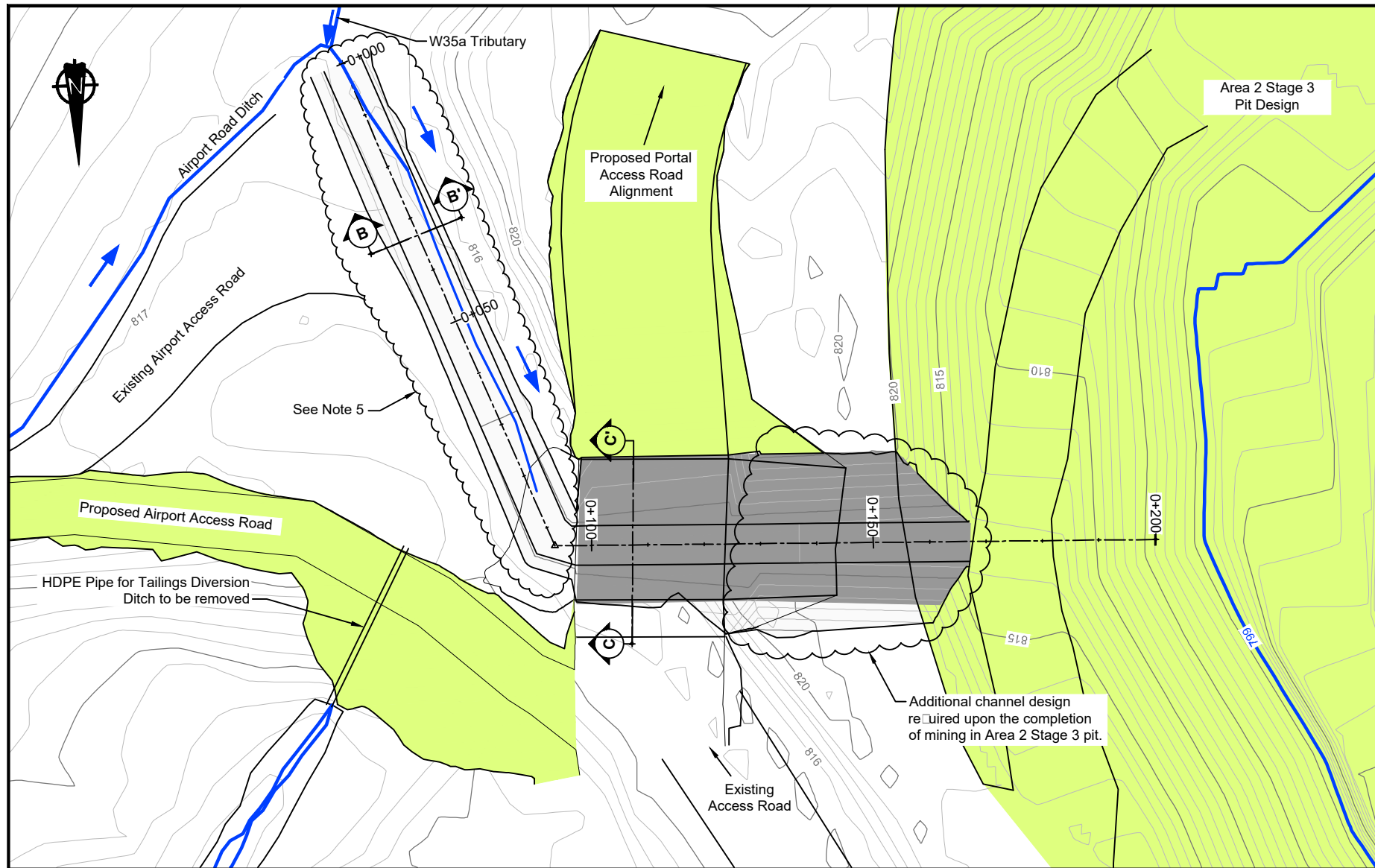

**PLAN VIEW
B CONVEYANCE CHANNEL**
Scale in Metres
0 5 10 15 20 25

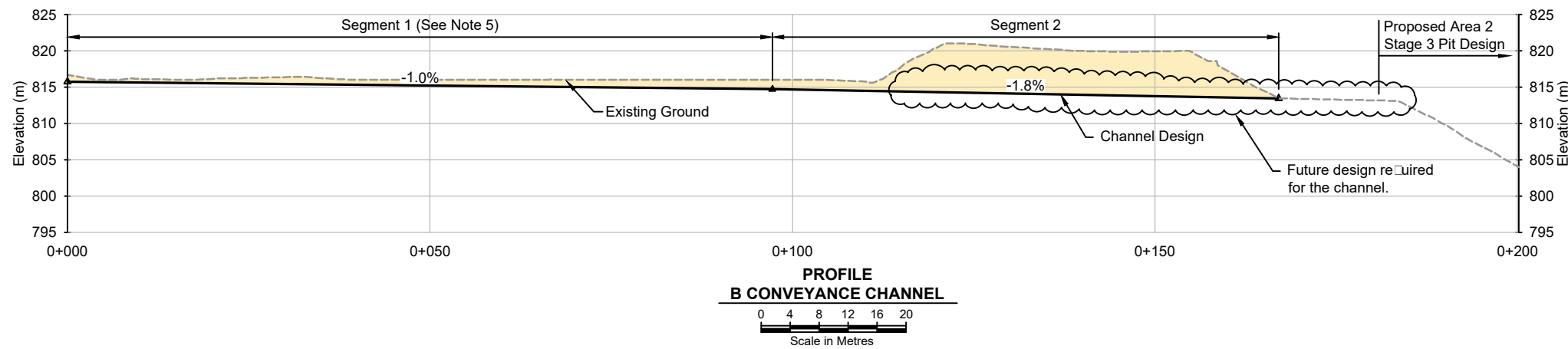

**PROFILE
B CONVEYANCE CHANNEL**
Scale in Metres
0 4 8 12 16 20

LEGEND

- Conveyance Channel Design
- Channel Fill
- Channel Excavation
- Designed Infrastructure (Not Constructed)
- Pit Lake Elevation
- Access Roads - Design Toes & Crests
- Flow Direction

NOTES

1. Contour interval 1m.
2. Digital topographic surfaces have been provided by Minto Explorations Ltd.
3. Topographic surfaces are comprised of existing and designed surfaces.
4. Swale crossing design for light vehicle access.
5. Segment 1 is a pre-existing channel that requires upgrades to closure design geometry. Channel transitions between existing and designed must be re-assessed upon the completion of mining activities at the Area 2 Stage 3 pit and the construction of the Portal Access Road.
6. Rip Rap classification gradation tables are provided in Drawing CC-06.
7. All notes on this drawing apply to all other drawings in this package.

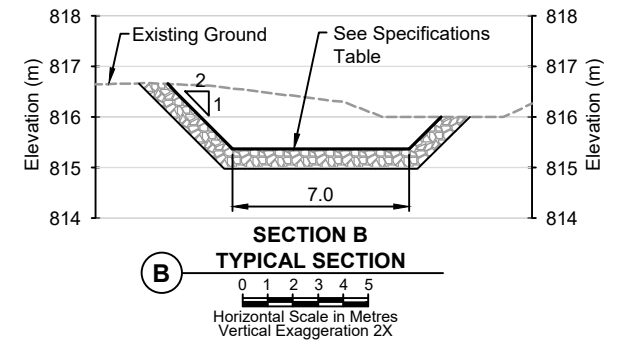

**SECTION B
TYPICAL SECTION**
Horizontal Scale in Metres
Vertical Exaggeration 2X

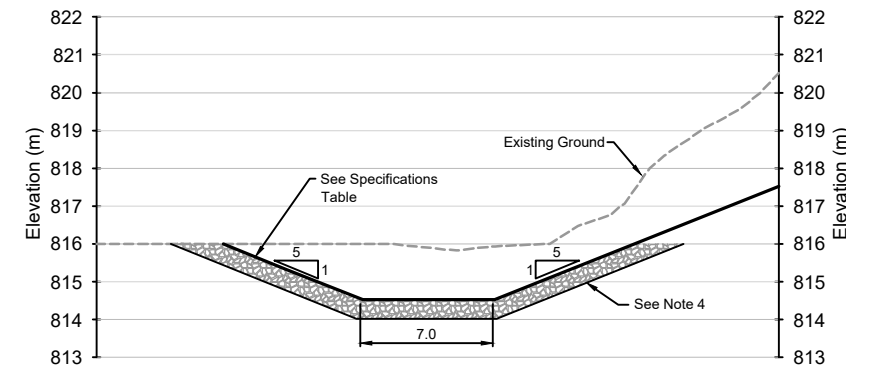

**SECTION C
TYPICAL SWALE SECTION**
Horizontal Scale in Metres
Vertical Exaggeration 2X

CHANNEL A SPECIFICATIONS:

Segment	Length (m)	Slope (%)	Channel Depth (m)	Water Depth for 1:200 yrs (m)	Rip-rap Class (kg)	Rip-rap Thickness (mm)
1	97	-1.0	1.20	0.60	10	350
2	70	-1.8	1.20	0.50	10	350

NOT FOR CONSTRUCTION

C:\MINTO\CLIENTS\SRK\CONC\B\MINTO_CLOSURE\1CM002_042-1.dwg

DRAWING NO.	DRAWING TITLE	DRAWING NO.	DRAWING TITLE

REFERENCE DRAWINGS

NO.	DESCRIPTION	CHK'D	APP'D	DATE

REVISIONS

This drawing is uncontrolled when printed unless stamped and signed with original ink and recorded on a Distribution Register.

PROFESSIONAL ENGINEERS STAMP



DESIGN: SM DRAWN: NV REVIEWED: SM
 CHECKED: SM APPROVED: DM DATE: July 2016
 FILE NAME: 1CM002_042-1.dwg



MINTO EXPLORATIONS Ltd.
 SRK JOB NO.: 1CM002.042

Closure Conveyance Design
 DRAWING TITLE:
B Conveyance Channel
 DRAWING NO. CC-03 SHEET 4 OF 10 REVISION NO. A

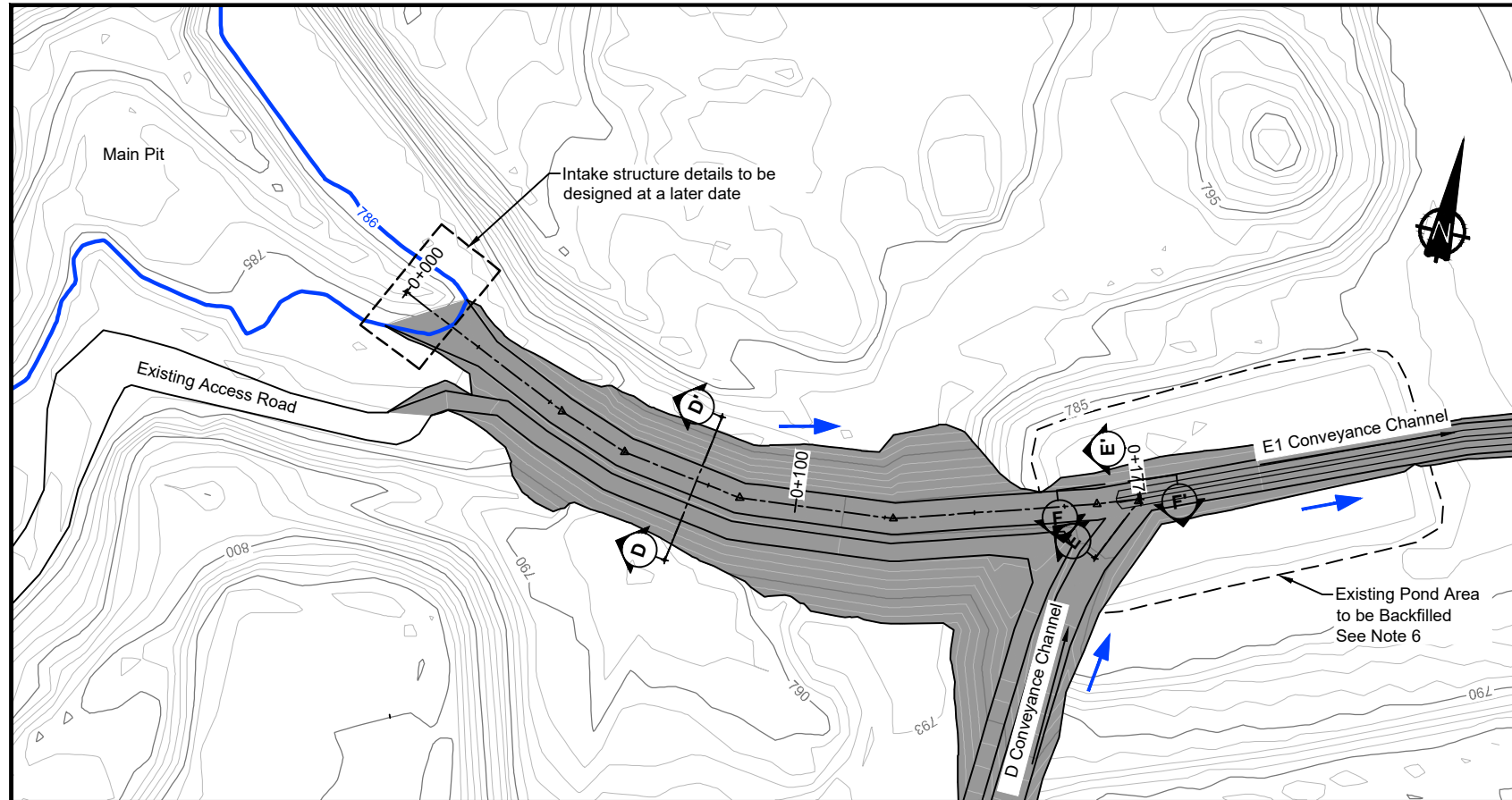

**PLAN VIEW
C CONVEYANCE CHANNEL**
0 5 10 15 20 25
Scale in Metres

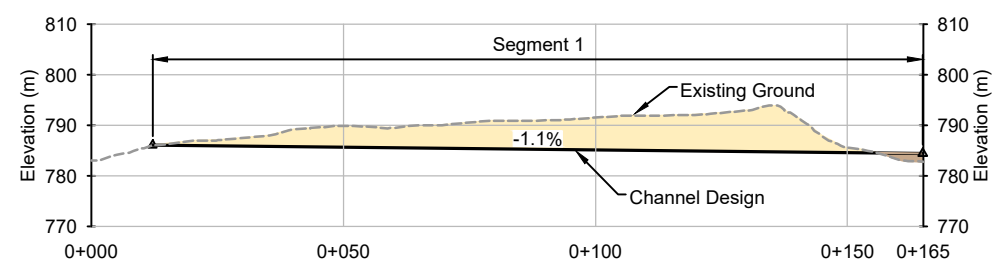

**PROFILE
C CONVEYANCE CHANNEL**
0 5 10 15 20 25
Scale in Metres

CHANNEL C SPECIFICATIONS:

Segment	Length (m)	Slope (%)	Channel Depth (m)	Water Depth for 1:200 yrs (m)	Rip-rap Class (kg)	Rip-rap Thickness (mm)
1	152	-1.1	1.70	0.80	10	350

- LEGEND**
- Conveyance Channel Design
 - Channel Fill
 - Channel Excavation
 - Pit Lake Elevation
 - Design Toes & Crests
 - Flow Direction

- NOTES**
1. Contour interval 1m.
 2. Digital topographic surfaces have been provided by Minto Explorations Ltd.
 3. North wall of Section D is anticipated to have a bedrock out cropping. The extent of the bed rock along the profile is undetermined.
 4. The confluence of Channels D and C are to be constructed with a Rip rap extended downstream of the confluence with 250kg Class Rip Rap classification gradation tables are provided in Drawing CC-06.
 5. An existing ponded area will be backfilled and graded prior to channel construction. Where possible the fill material will be graded such that surface runoff will be conveyed into the conveyance channel.
 6. All notes on this drawing apply to all other drawings in this package.

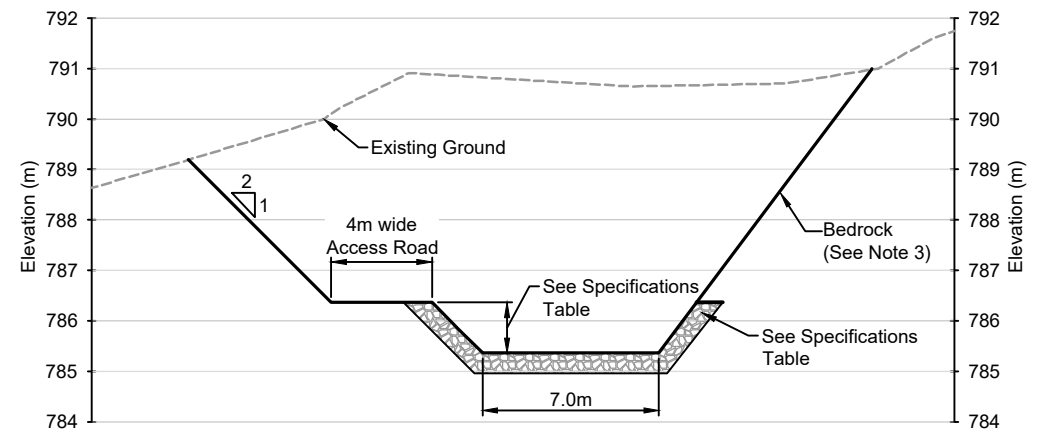

**SECTION D
TYPICAL SECTION**
0 1 2 3 4 5
Horizontal Scale in Metres
Vertical Exaggeration 2X

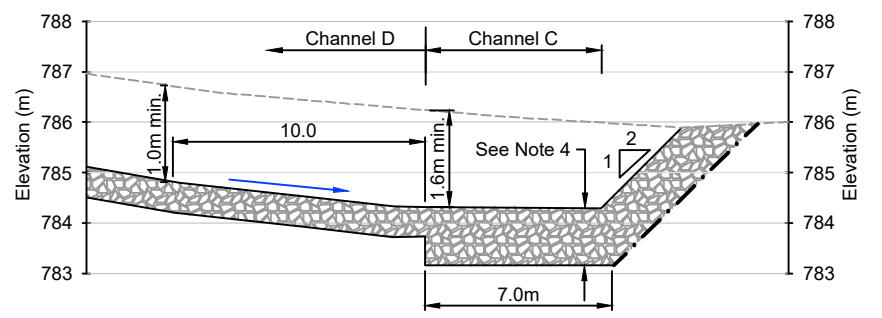

**SECTION E
TYPICAL SECTION**
0 1 2 3 4 5
Horizontal Scale in Metres
Vertical Exaggeration 2X

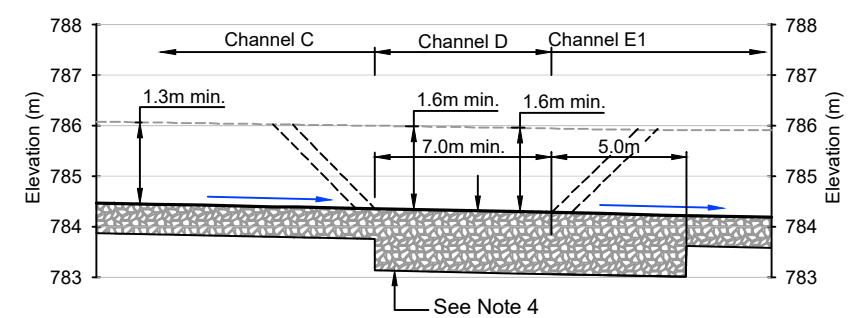

**SECTION F
TYPICAL SECTION**
0 1 2 3 4 5
Horizontal Scale in Metres
Vertical Exaggeration 2X

NOT FOR CONSTRUCTION

								Closure Conveyance Design		
DESIGN: SM DRAWN: NV REVIEWED: SM				CHECKED: SM APPROVED: DM DATE: July 2016				MINTO EXPLORATIONS Ltd.		
FILE NAME: 1CM002_042-1.dwg				SRK JOB NO.: 1CM002.042				DRAWING TITLE: C Conveyance Channel		
DRAWING NO.		DRAWING TITLE		DRAWING NO.		DRAWING TITLE		DRAWING NO.	SHEET	REVISION NO.
REFERENCE DRAWINGS		REVISIONS		A Issued for Review SM - 15Jul16		PROFESSIONAL ENGINEERS STAMP		CC-04	5 OF 10	A

C:\MDS\CLIENTS\SRK\2016\MINTO CLOSURE\1CM002_042-1.dwg

This drawing is uncontrolled when printed unless stamped and signed with original ink and recorded on a Distribution Register.

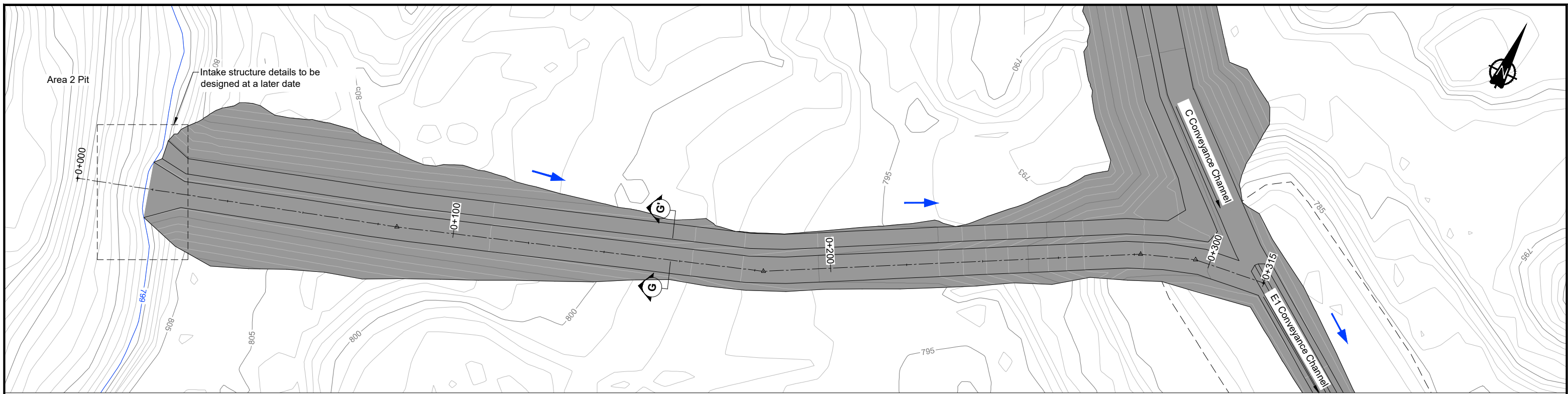

**PLAN VIEW
D CONVEYANCE CHANNEL**

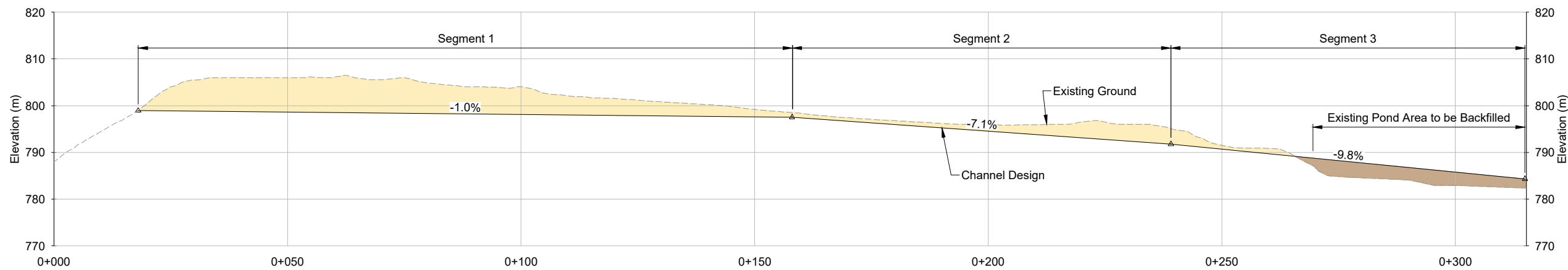
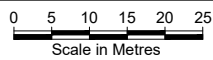

**PROFILE
D CONVEYANCE CHANNEL**

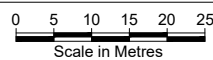

LEGEND

- Conveyance Channel Design
- Channel Fill
- Channel Excavation
- Pit Lake Elevation
- Design Toes & Crests
- Flow Direction

NOTES

1. Contour interval 1m.
2. Digital topographic surfaces have been provided by Minto Explorations Ltd.
3. Access road paralleling channel to be connected with the site wide access roads for mine closure.
4. Rip Rap classification gradation tables are provided in Drawing CC-06.
5. All notes on this drawing apply to all other drawings in this package.

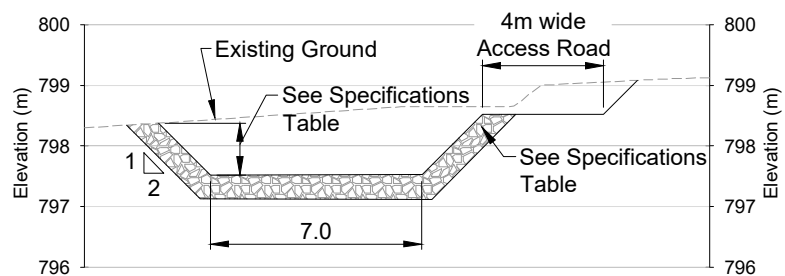

SECTION G



CHANNEL D SPECIFICATIONS:

Segment	Length (m)	Slope (%)	Channel Depth (m)	Water Depth for 1:200 yrs (m)	Rip-rap Class (kg)	Rip-rap Thickness (mm)
1	140	-1.0	1.30	0.70	10	350
2	82	-7.10	1.00	0.40	25	450
3	75	-9.80	1.00	0.40	25	450

NOT FOR CONSTRUCTION

C:\MDS\CLIENTS\SRK\2016\MINTO_CLOSURE\CM002_042_1.dwg

DRAWING NO.	DRAWING TITLE	DRAWING NO.	DRAWING TITLE	NO.	DESCRIPTION	CHK'D	APP'D	DATE
				A	Issued for Review	SM	-	15Jul16
REFERENCE DRAWINGS				REVISIONS				

This drawing is uncontrolled when printed unless stamped and signed with original ink and recorded on a Distribution Register.

PROFESSIONAL ENGINEERS STAMP

srk consulting

DESIGN: SM DRAWN: NV REVIEWED: SM
 CHECKED: SM APPROVED: DM DATE: July 2016

FILE NAME: 1CM002_042-1.dwg

capstone
MINTO MINE
OPERATED BY MINTO EXPLORATIONS LTD.

MINTO EXPLORATIONS Ltd.

SRK JOB NO.: 1CM002.042

Closure Conveyance Design

DRAWING TITLE:
D Conveyance Channel

DRAWING NO.: **CC-05** SHEET: 6 OF 10 REVISION NO.: **A**

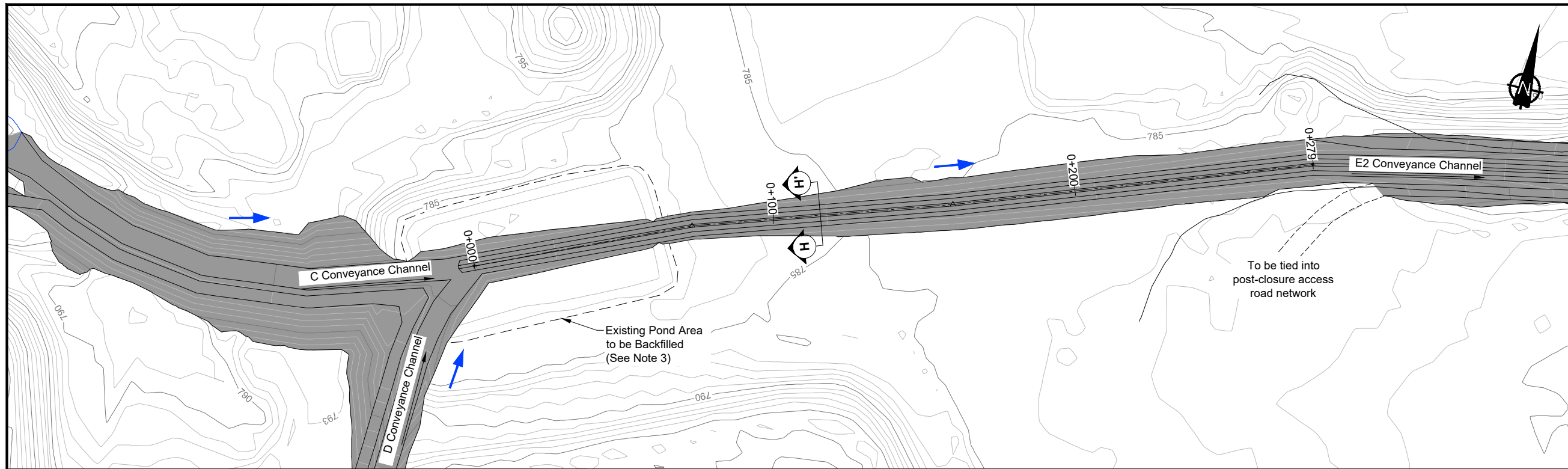

- LEGEND**
- Conveyance Channel Design
 - Channel Fill
 - Channel Excavation
 - Design Toes & Crests
 - Flow Direction

- NOTES**
1. Contour interval 1m.
 2. Digital topographic surfaces have been provided by Minto Explorations Ltd.
 3. An existing ponded area will be backfilled and graded prior to channel construction. Where possible the fill material will be graded such that surface runoff will be conveyed into the conveyance channel.
 4. Channel E is constructed with a typical pilot channel in the base of the main channel. The pilot channel is designed to convey the 1:10 year peak flow.
 5. All notes on this drawing apply to all other drawings in this package.

**PLAN VIEW
E1 CONVEYANCE CHANNEL**

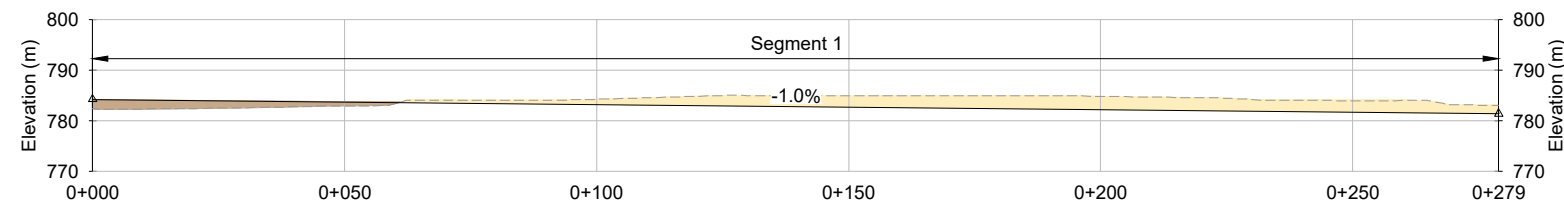
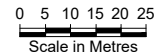

Section H for E1

**PROFILE
E1 CONVEYANCE CHANNEL**

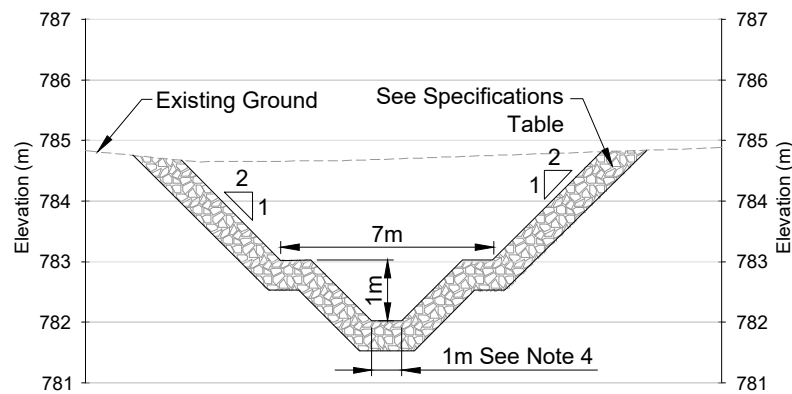
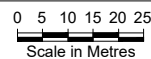

**SECTION H
TYPICAL SECTION**
Horizontal Scale in Metres
Vertical Exaggeration 2X

CHANNEL E SPECIFICATIONS:

Segment	Length (m)	Slope (%)	Channel Depth (m)	Water Depth for 1:200 yrs (m)	Rip-rap Class (kg)	Rip-rap Thickness (mm)
1	279	-1.1	2.0	1.00	10	350
2	38	-1.9	2.0	1.70	25	450
3	222	-7.0	2.0	1.40	100	700
4	98	-1.4	2.0	1.80	10	350
5	163	-6.0	2.0	1.50	100	700
6	104	-4.1	2.0	1.60	100	700
7	33	-7.6	2.0	1.40	100	700
8	47	-5.1	2.0	1.50	100	700
9	150	20.0	1.2	1.10	1000	1000
10	20	0.5	1.6	1.00	25	450
11	20	0.5	1.6	1.50	10	350

10 kg CLASS - RIP RAP

Material Type	Rip Rap Dia. (mm)
D ₁₀₀	300
D ₈₅	280
D ₅₀	200
D ₁₅	90
Layer Thickness	350

25kg CLASS - RIP RAP

Material Type	Rip Rap Dia. (mm)
D ₁₀₀	450
D ₈₅	380
D ₅₀	300
D ₁₅	130
Layer Thickness	450

250kg CLASS - RIP RAP

Material Type	Rip Rap Dia. (mm)
D ₁₀₀	900
D ₈₅	820
D ₅₀	600
D ₁₅	270
Layer Thickness	1000

100 kg CLASS - RIP RAP

Material Type	Rip Rap Dia. (mm)
D ₁₀₀	680
D ₈₅	610
D ₅₀	450
D ₁₅	200
Layer Thickness	700

1000kg CLASS - RIP RAP

Material Type	Rip Rap Dia. (mm)
D ₁₀₀	1500
D ₈₅	1300
D ₅₀	1000
D ₁₅	420
Layer Thickness	1500

NOT FOR CONSTRUCTION

C:\MDS\CLIENTS\SRK\2016\MINTO CLOSURE\CM002_042.dwg

DRAWING NO.	DRAWING TITLE	DRAWING NO.	DRAWING TITLE	NO.	DESCRIPTION	CHK'D	APP'D	DATE
				A	Issued for Review	SM	-	15Jul16
REFERENCE DRAWINGS				REVISIONS				

This drawing is uncontrolled when printed unless stamped and signed with original ink and recorded on a Distribution Register.

PROFESSIONAL ENGINEERS STAMP



DESIGN: SM	DRAWN: NV	REVIEWED: SM
CHECKED: SM	APPROVED: DM	DATE: July 2016
FILE NAME: 1CM002_042-1.dwg		



MINTO EXPLORATIONS Ltd.

SRK JOB NO.: 1CM002.042

Closure Conveyance Design		
DRAWING TITLE: E1 Conveyance Channel		
DRAWING NO. CC-06	SHEET 7 OF 10	REVISION NO. A

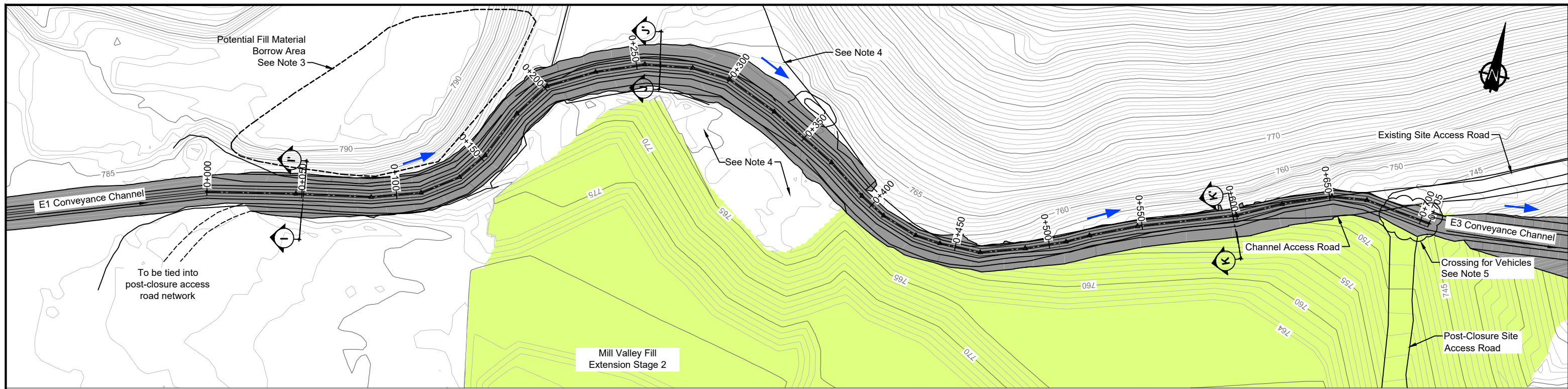

LEGEND

- Conveyance Channel Design
- Designed Infrastructure (Not Constructed)
- Design Toes & Crests
- Flow Direction

**PLAN VIEW
E2 CONVEYANCE CHANNEL**

Scale in Metres

NOTES

1. Contour interval 1m.
2. Digital topographic surfaces have been provided by Minto Explorations Ltd.
3. Extents and depth of the potential fill material borrow area has not been defined for this stage of design. Area identified as a potential source due to overburden thickness.
4. Backfill and regrading required to convey surface water to conveyance channel.
5. A light vehicle crossing is to be designed into the closure conveyance channel upon the completion of channel construction. A swale crossing with 5:1 side slopes should be considered during design and alignment selection.
6. All notes on this drawing apply to all other drawings in this package

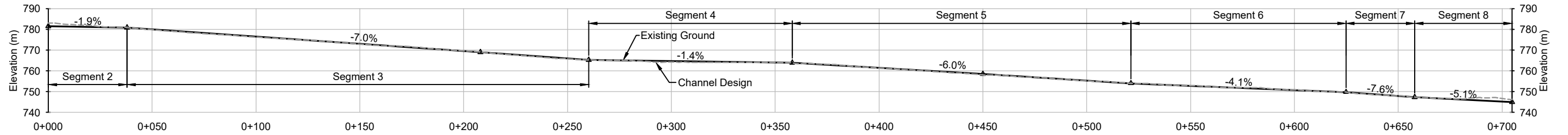

**PROFILE
E2 CONVEYANCE CHANNEL**

Scale in Metres

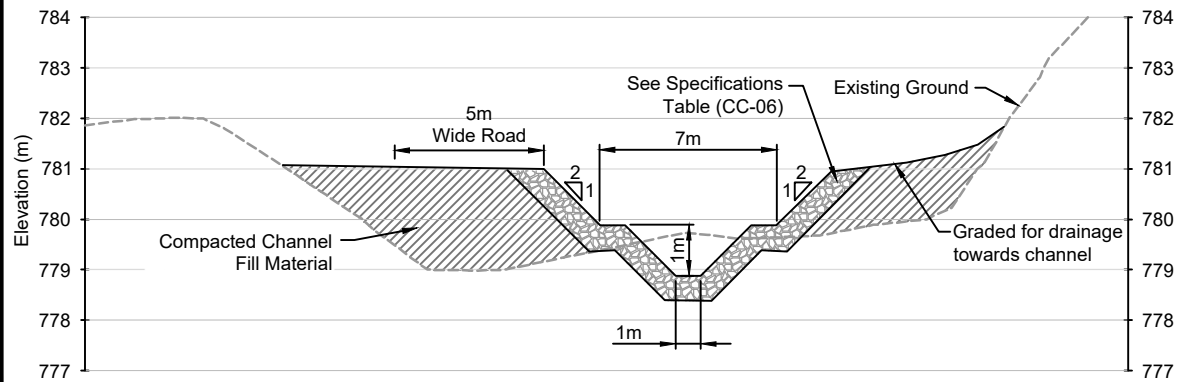

I TYPICAL SECTION FROM 0+000 TO 0+200

Horizontal Scale in Metres
Vertical Exaggeration 2X

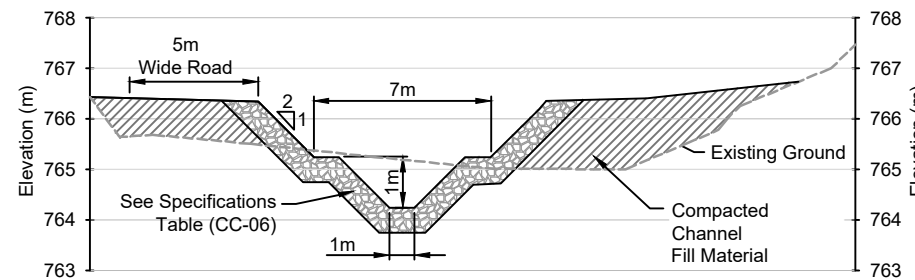

J TYPICAL SECTION FROM 0+200 TO 0+380

Horizontal Scale in Metres
Vertical Exaggeration 2X

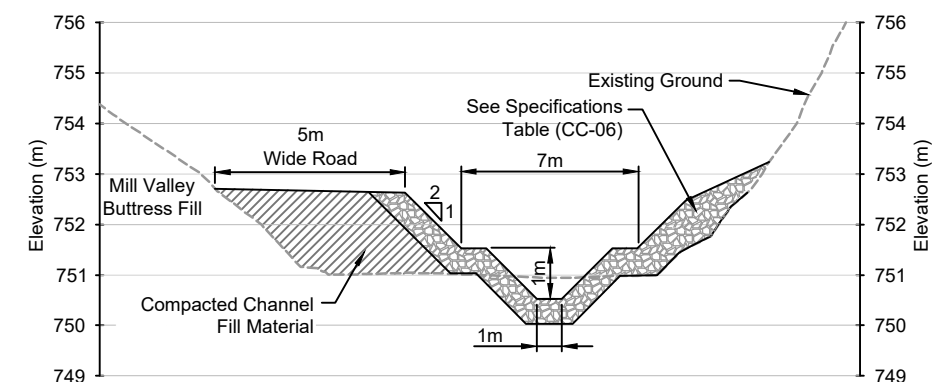

K TYPICAL SECTION FROM 0+380 TO 0+704

Horizontal Scale in Metres
Vertical Exaggeration 2X

NOT FOR CONSTRUCTION

DRAWING NO.	DRAWING TITLE	DRAWING NO.	DRAWING TITLE
REFERENCE DRAWINGS			
NO.	DESCRIPTION	CHKD	APP'D
REVISIONS			

This drawing is uncontrolled when printed unless stamped and signed with original ink and recorded on a Distribution Register.

PROFESSIONAL ENGINEERS STAMP



DESIGN: SM	DRAWN: NV	REVIEWED: SM
CHECKED: SM	APPROVED: DM	DATE: July 2016
FILE NAME: 1CM002_042-1.dwg		



MINTO EXPLORATIONS Ltd.

SRK JOB NO.: 1CM002.042

Closure Conveyance Design		
DRAWING TITLE:		
E2 Conveyance Channel		
DRAWING NO.	SHEET	REVISION NO.
CC-07	8 OF 10	A

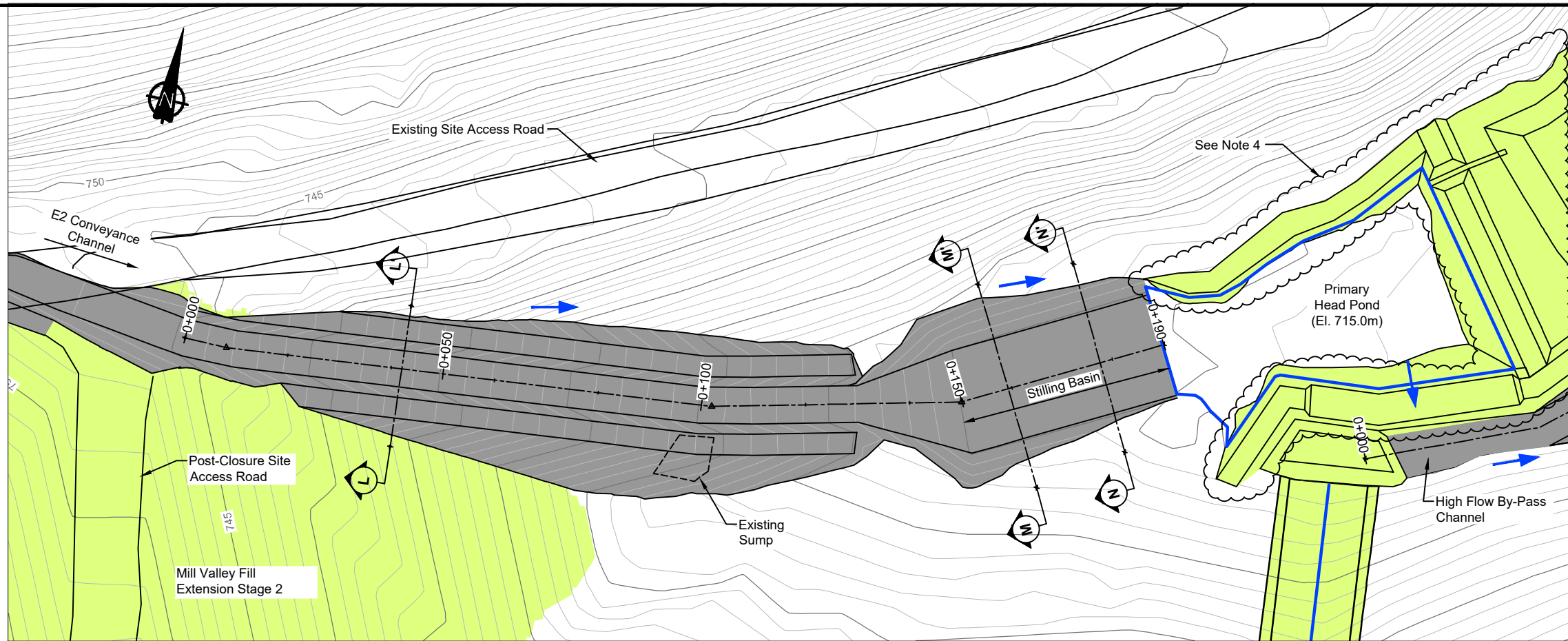

- LEGEND**
- Conveyance Channel Design
 - Channel Fill
 - Channel Excavation
 - Designed Infrastructure (Not Constructed)
 - Design Toes & Crests
 - Flow Direction

- NOTES**
1. Contour interval 1m.
 2. Digital topographic surfaces have been provided by Minto Explorations Ltd.
 3. Stilling basin design rip rap specifications are located in the specifications tables in Drawing CC-06.
 4. Wetland Infrastructure Design prepared by SRK. Refer to Wetland Infrastructure Design Report (SRK 2016).
 5. All notes on this drawing apply to all other drawings in this package.

**PLAN VIEW
E3 CONVEYANCE CHANNEL**

0 5 10 15 20 25
Scale in Metres

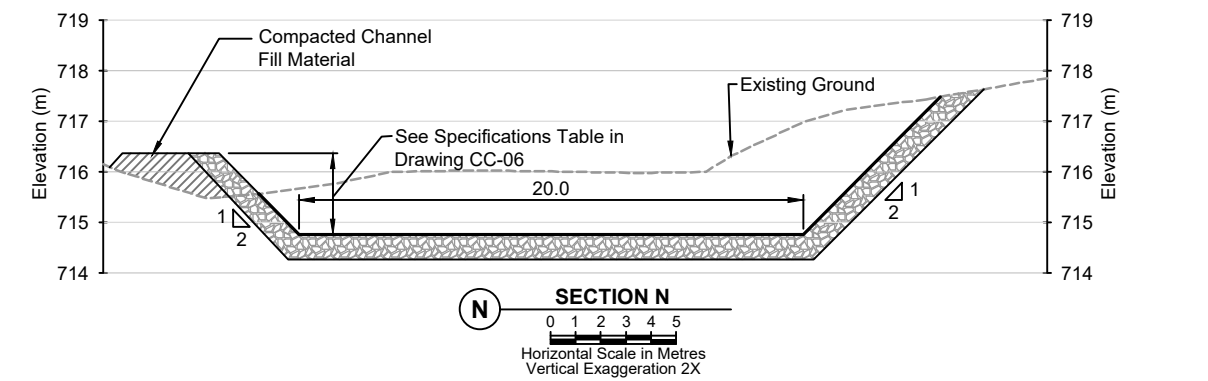
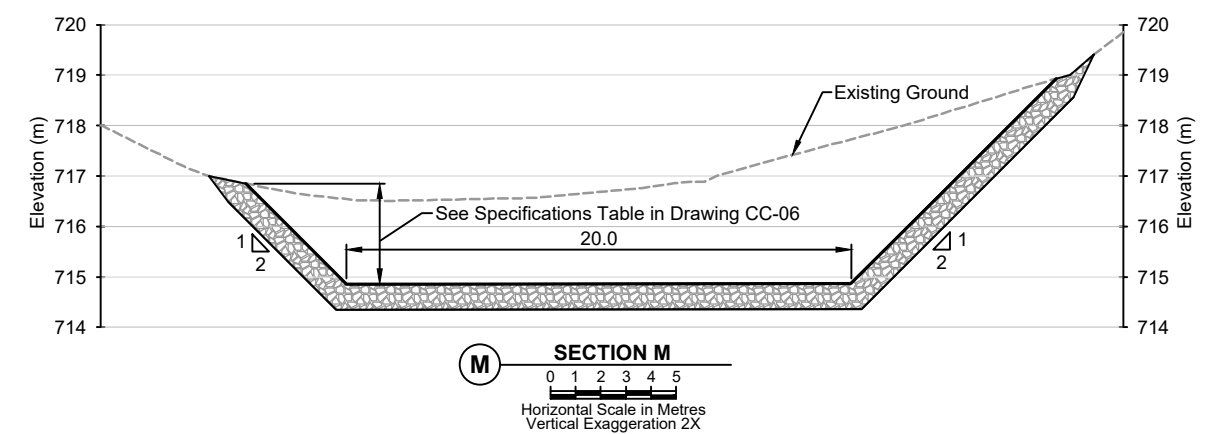
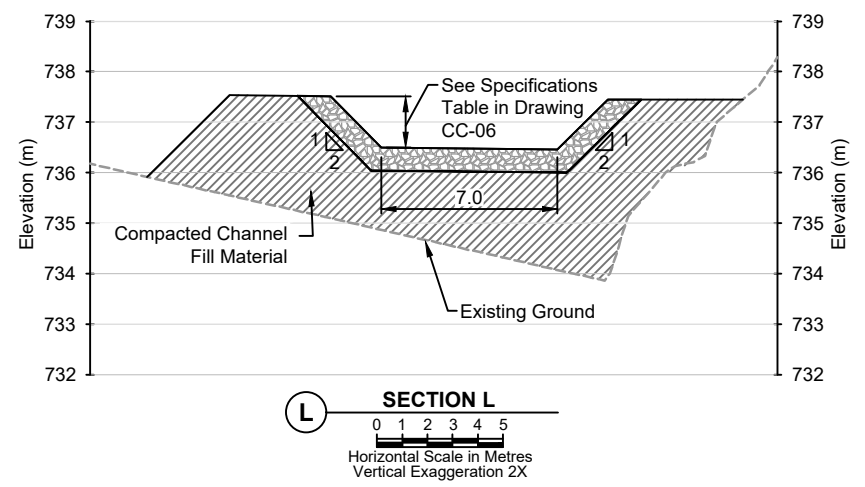
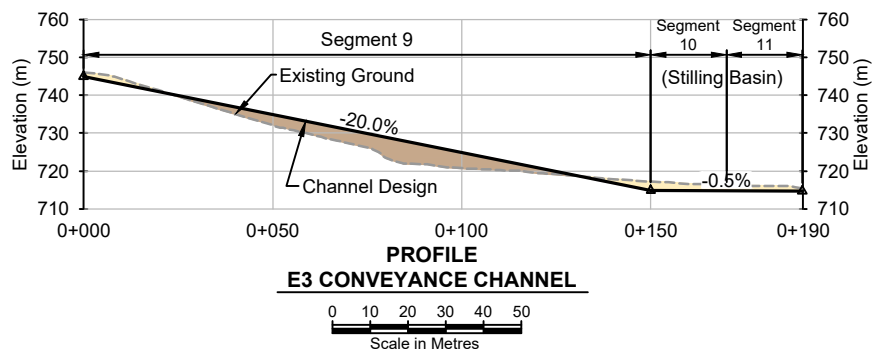

NOT FOR CONSTRUCTION

C:\MINTO\CLIENTS\SRK\CONSTRUCTION\CLOSURE\CM02_042_1.dwg

												<p align="center">Closure Conveyance Design</p> <p align="center">DRAWING TITLE:</p> <p align="center">E3 Conveyance Channel and Stilling Basin</p>			
				<p>DESIGN: SM DRAWN: NV REVIEWED: SM</p> <p>CHECKED: SM APPROVED: DM DATE: July 2016</p> <p>FILE NAME: 1CM002_042-1.dwg</p>				<p align="center">MINTO EXPLORATIONS Ltd.</p> <p align="center">SRK JOB NO.: 1CM002.042</p>				<p align="center">DRAWING NO. CC-08 SHEET 9 OF 10 REVISION NO. A</p>			
DRAWING NO.			DRAWING TITLE			DRAWING NO.			DRAWING TITLE			NO.			
REFERENCE DRAWINGS						REVISIONS						PROFESSIONAL ENGINEERS STAMP			
												<p align="center">A Issued for Review SM - 15Jul16</p> <p align="center">NO. DESCRIPTION CHK'D APP'D DATE</p>			

This drawing is uncontrolled when printed unless stamped and signed with original ink and recorded on a Distribution Register.

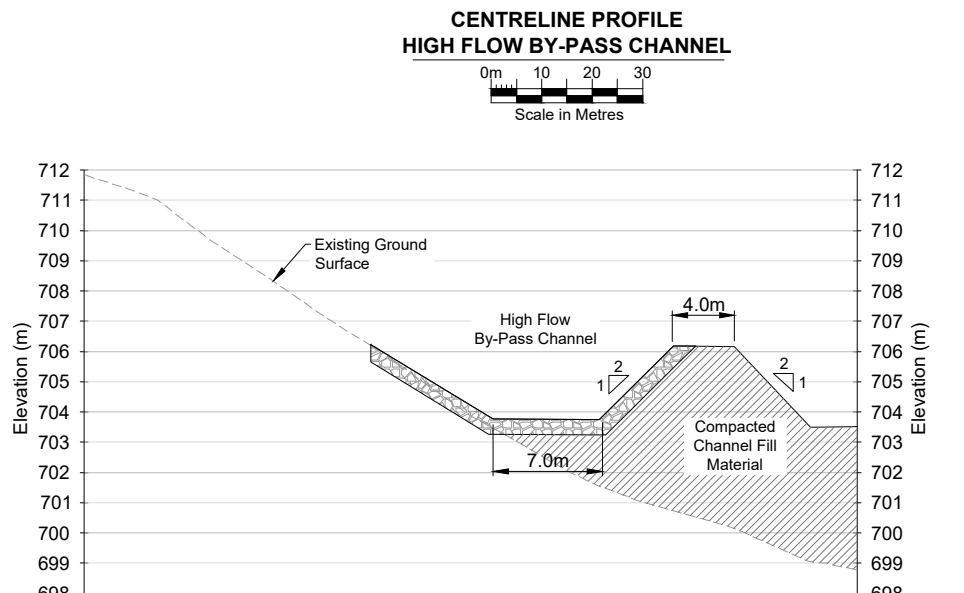
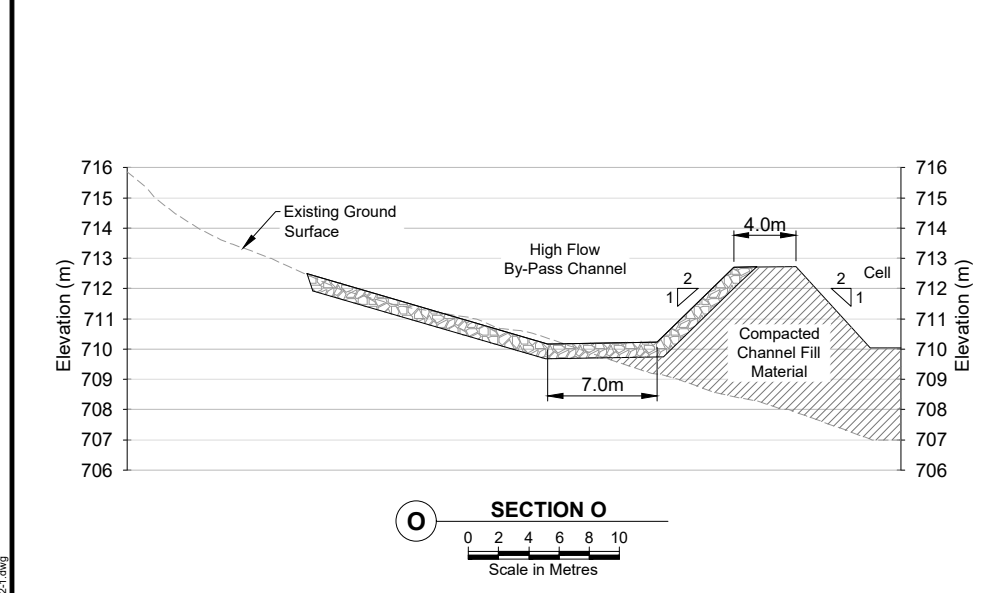
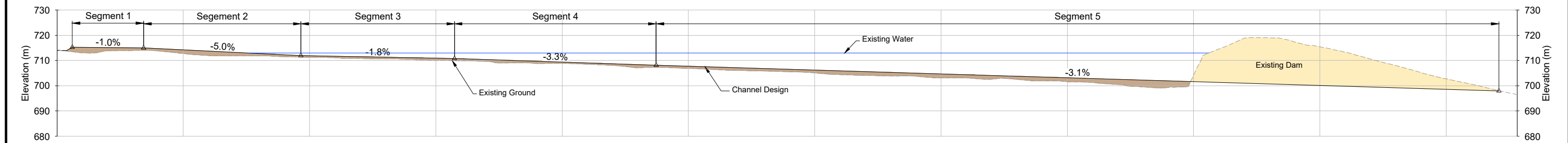
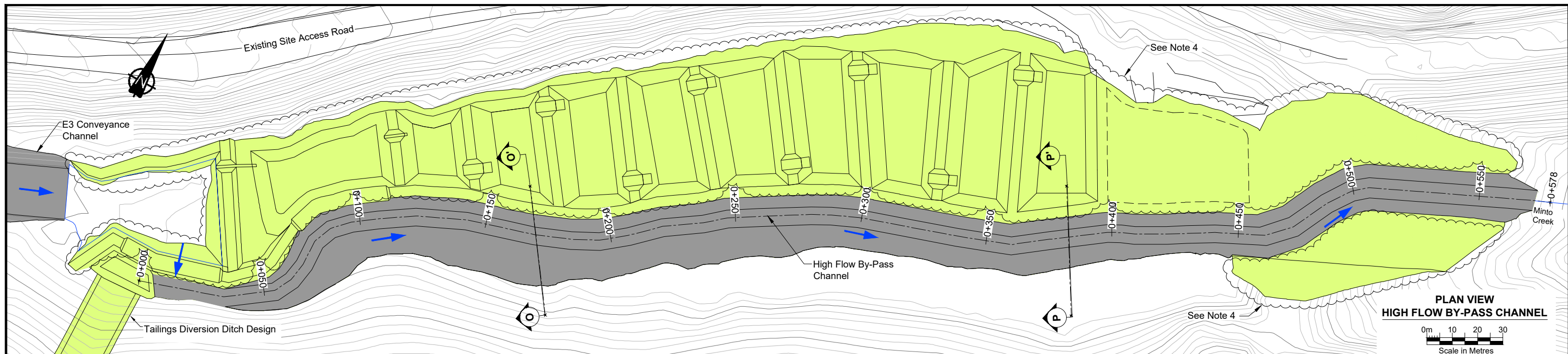

LEGEND

	Conveyance Channel Design		Designed Infrastructure (Not Constructed)
	Channel Fill		Design Toes & Crests
	Channel Excavation		

- NOTES**
1. Contour interval 1m.
 2. Digital topographic surfaces have been provided by Minto Explorations Ltd.
 3. Stilling basin design rip rap specifications are located in the specifications tables in Drawing CC-06.
 4. Wetland Infrastructure Design prepared by SRK. Refer to Wetland Infrastructure Design Report (SRK 2016).
 5. All notes on this drawing apply to all other drawings in this package.

CHANNEL HIGH FLOW BY-PASS CHANNEL SPECIFICATIONS:

Segment	Length (m)	Slope (%)	Channel Depth (m)	Water Depth for 1:200 yrs (m)	Rip-rap Class (kg)	Rip-rap Thickness (mm)
1	28	-1.0	2.4	1.2	25	450
2	62	-5.0	2.0	0.5	25	450
3	61	-1.8	2.0	1.0	25	450
4	84	-3.3	2.0	1.0	25	450
5	334	-3.1	2.0	1.0	25	450

NOT FOR CONSTRUCTION

								Closure Conveyance Design			
				MINTO EXPLORATIONS Ltd.				High Flow By-Pass Channel			
DESIGN: SM DRAWN: NV REVIEWED: SM CHECKED: SM APPROVED: DM DATE: July 2016				FILE NAME: 1CM002_042-1.dwg				SRK JOB NO.: 1CM002.042			
DRAWING NO. DRAWING TITLE DRAWING NO. DRAWING TITLE				REVISIONS				DRAWING NO. SHEET REVISION NO. CC-09 10 OF 10 A			

Appendix B – Site-Specific Hydrology Review

Memo

To:	Ryan Herbert, Minto Explorations Ltd.	Client:	Minto Explorations Ltd.
From:	Samantha Barnes Victor Muñoz S. Francis Smith	Project No:	1CM002.042
Cc:	Dylan MacGregor, SRK	Date:	August 3, 2016
Subject:	Site-Specific Hydrology Review, Minto Mine, Yukon		

1 Introduction

SRK Consulting (Canada) Inc. has prepared an updated closure water conveyance plan design report for Minto Mine (Minto) located in Yukon, Canada, and operated by Minto Explorations Ltd. In support of the updates to the conveyance designs, SRK reviewed and updated site-wide hydrology models to include potential influences resulting from future climate change and alterations to watershed catchment areas. Inputs to the modelling are listed as follows:

- Rainfall depths for short duration storms for return periods ranging from the 1:2 through the 1:200 year precipitation event
- Maximum snowmelt depth expected over a 24-hour period
- Probable maximum precipitation (PMP) over a 24-hour period
- Hydrological curve number calibrated for regional catchment
- Hydrologic model to estimate peak flows for each structure

The updated hydrology models were used to estimate 1:10 and 1:200 year return period events. These events are the main inputs utilized for the use of designing the closure conveyance channels and related erosion protection required for the revised closure plan.

This memorandum outlines the formulation of inputs required for the closure conveyance designs.

2 Supporting Information from Public Databases

Regional historic precipitation data was obtained from the Meteorological Service of Canada (MSC) division of Environment Canada (EC 2015a). Regional stations were included in the studies for short duration rainfall, mean annual precipitation (MAP) and probable maximum precipitation (PMP).

Regional daily hydrometric data was obtained from the Water Survey of Canada (WSC) within an approximate 300 km radius surrounding the site for the unit peak flow analysis (EC 2015b).

Precipitation intensity–duration–frequency (IDF) estimation was derived utilizing short-duration rainfall IDF statistics obtained from the Government of Canada’s Engineering Climate Dataset (Government of Canada 2016).

3 Precipitation

3.1 Mean Annual Precipitation

Regional regression analyses were performed using the 20 nearest MSC meteorological stations. RStudio® software (version 3.2.3; i386 - w64) was used to calculate mean annual precipitation for each station. Table 3-1 presents the station locations, distance relative to the site and their respective MAP estimates.

Table 3-1: Regional Meteorological Stations and MAP

Station Name	Longitude	Latitude	MAP [mm]	Elevation	Distance
PELLY RANCH	-137.4	62.8	309	454	23
CARMACKS	-136.3	62.1	282	525	75
STEWART CROSSING	-136.7	63.4	332	480	89
MCQUESTEN	-137.5	63.6	349	458	109
MAYO A	-135.9	63.6	304	504	131
STEWART RIVER	-139.4	63.3	294	358	136
DRURY CREEK	-134.4	62.2	373	609	154
SNAG A	-140.4	62.4	366	587	165
ELSA	-135.5	63.9	430	814	170
KENO HILL	-135.2	63.9	585	1473	178
DAWSON A	-139.1	64.0	323	370	184
BEAVER CREEK A	-140.9	62.4	413	649	188
BEAVER CREEK YTG	-140.9	62.4	414	663	189
ANVIL	-133.4	62.4	389	1158	200
FARO A	-133.4	62.2	318	716	205
KLONDIKE	-138.2	64.5	468	973	210
CLINTON CREEK	-140.7	64.5	344	576	269
OGILVIE RIVER	-138.3	65.4	340	597	310

Figure 3-1 includes a location map of the stations used in the MAP analysis. It also presents the subsequent regression analysis for MAP against elevation and the monthly precipitation distributions.

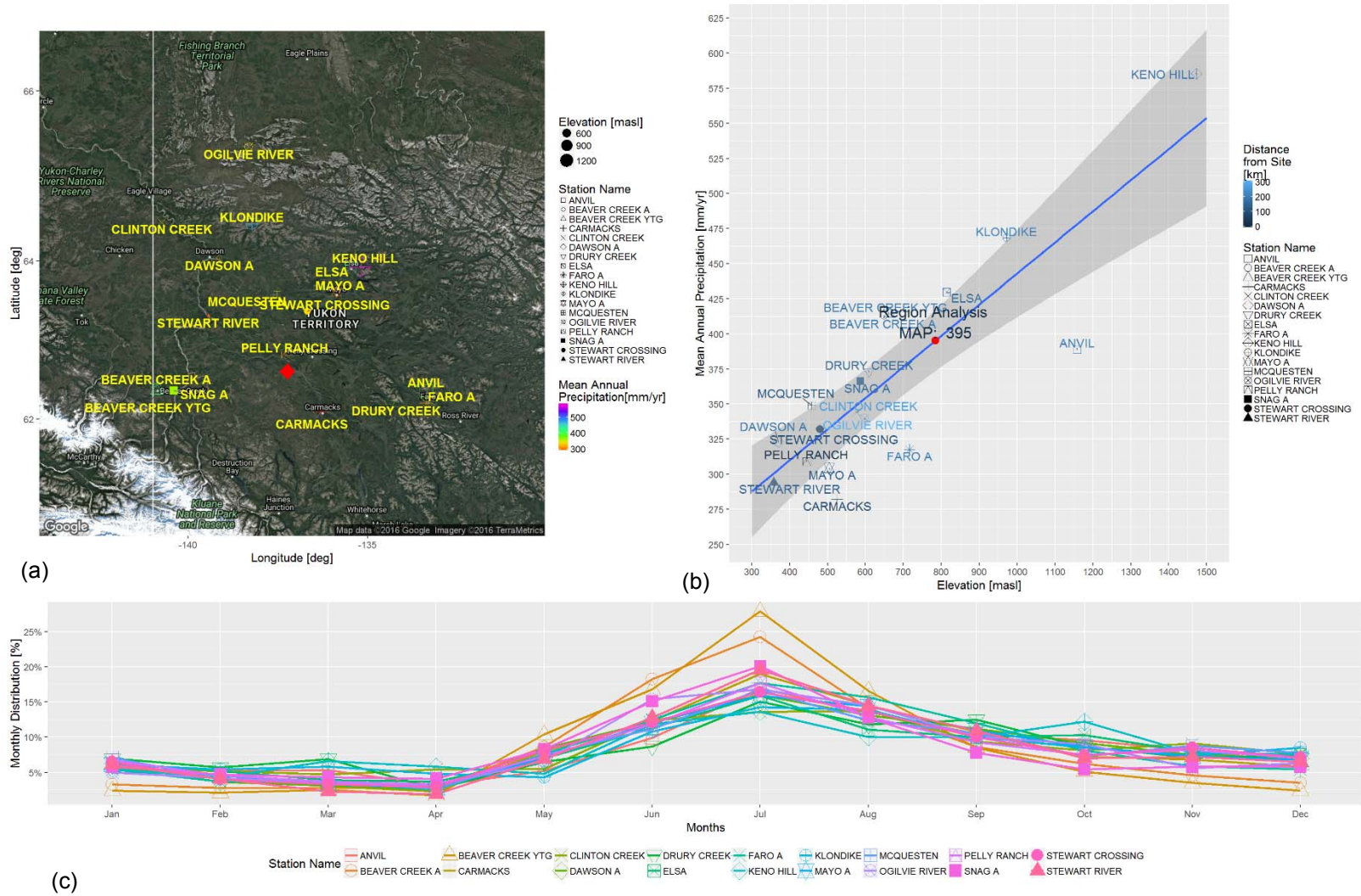

Figure 3-1: MAP Analysis Station Locations (a), Regional Regression Analysis (b), and Monthly Precipitation Distributions (c)

Based on the MAP versus elevation regression analysis and an average site elevation of 784 meters above sea level (masl), the MAP for Minto is estimated to be 395 mm.

3.2 Precipitation-Duration-Frequency Analysis

Short-duration storm analyses provide an estimation of the amount of precipitation expected for a storm return period ranging from 2 to 200 years with durations ranging from 5 minutes to 24 hours. A regional analysis was performed in order to understand the relationships between return period, duration, and rainfall for stations within close proximity to the site.

Using the results of the regional analysis, the precipitation-duration-frequency (PDF) data for the site was established using the following equation:

$$\text{Equation 1: } Pp_{\text{Duration hrs.}}^{\text{Frequency years}} = Pp_{24\text{hrs.}}^{10\text{yrs}} \cdot FF_{(\text{Frequency})} \cdot DF_{(\text{Duration})}$$

Where,

Pp is the precipitation as a function of storm frequency and duration;

$Pp_{24\text{hrs.}}^{10\text{yrs}}$ is the precipitation in 24 hours with a return period of 10 years;

FF are frequency factors, which correspond to the rate between precipitation associated with a defined frequency and the return period of 10 years; and

DF are duration factors, which correspond to the rate between the defined storm duration and a storm duration of 24 hours.

Duration and frequency factors for a 1:10 year, 24-hour precipitation event were established from the regional analysis. The following sections discuss how the design precipitation event was developed using the frequency factors.

3.2.1 One-in-Ten Year 24-hour Precipitation Event

This analysis was performed using the RStudio software, and was conducted using data obtained from the Environment Canada meteorological stations (Environment Canada 2015a) located throughout the Yukon (Figure 3-1). Frequency analyses were performed for each station to estimate the 1:10 year, 24-hour–duration precipitation depth. These values were then correlated with elevation, latitude, and longitude. The strongest correlation was with longitude, which was used to establish the 1:10 year precipitation for the site (Figure 3-2).

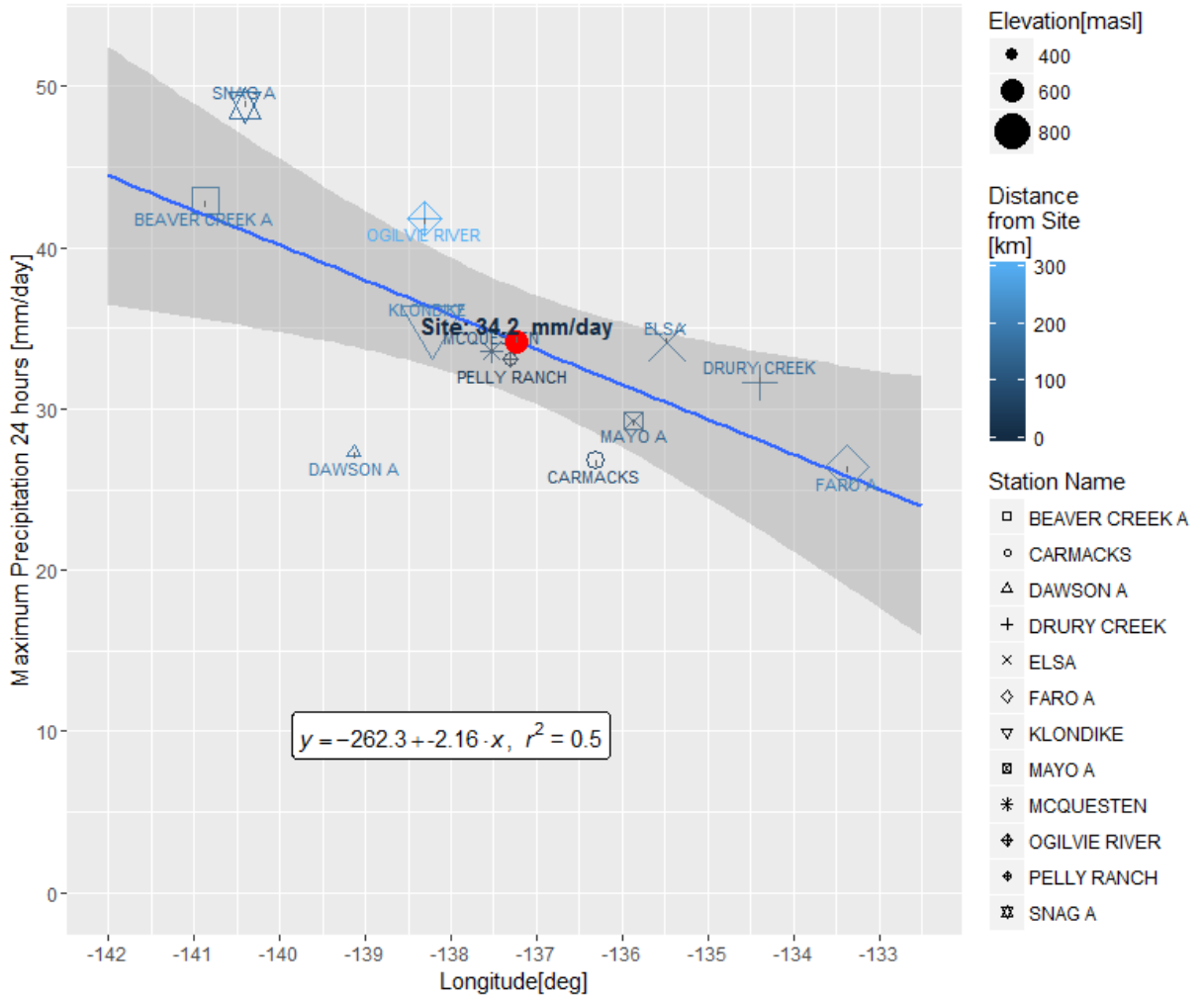

Figure 3-2: Regional Analysis for the 1:10 Year 24-hour Duration Rainfall Event

Based on the site longitude of -137.2 degrees, the 1:10 year 24-hour rainfall event is 34.2 mm.

3.2.2 Regional Intensity-Duration-Frequency Relationships

Five meteorological stations with IDF statistics all within 185 km of the site were located and are summarized in Table 3-2.

Table 3-2: Summary of Meteorological Stations Used for Short Duration Storm Event Analysis

Station Name	Latitude	Longitude	Elevation	Years of Data
Mayo A	-135.9	63.6	503.8	22
Pelly Ranch	-137.4	62.8	454.2	32
Dawson A	-139.1	64.0	370.3	26
Carmacks	-136.3	62.1	524.9	15
Burwash A	-139.1	61.4	806.2	13

The frequency analyses were prepared considering the following probabilistic distributions: Normal, Log Normal, GEV, Gumbel, Pearson III, and Log Pearson III. The selection of the distribution parameters was prepared with the L-moments methodology.

The L-moments approach provides a more robust estimation to outliers when compared with typical estimations. The selection of the best-fit distribution was prepared based on four criteria: Akaike Information Criterion, Corrected Akaike Information Criterion, Anderson-Darling Criterion, and Bayesian Information Criterion, as described by (Laio, Di Baldassarre, and Montanari 2009). These best-fit distributions were implemented using RStudio.

The results from the frequency analyses were compiled into an IDF table for each station. Duration and frequency factors for each regional station were calculated using an iterative optimization process, such that the product of the two factors and the 1:10 year, 24-hour precipitation depth would equal the rainfall depth for a given duration and frequency, based on Equation 1. The results were then compared regionally to determine the appropriate factors to be applied to the site.

Regional Trends in Duration Factors

The duration factors for each station were plotted against return period (Figure 3-3). The Burwash A station was found to behave differently from the other four stations, as shown in Figure 3-3. The Pearson distribution was used to determine whether the duration factors for each duration were related to the elevation, latitude, or longitude of the meteorological station. Regional analysis suggests this is likely due to the stations high elevation and geographic position within a valley immediately on the leeward side of the Saint Elias Mountains, with a greater orographic influence than the other stations and the project area, which are located further east within the lower elevation interior of Yukon. Consequently, the longitude of the site, -137.2 degrees, was used to establish the duration factors for each return period at site. Table 3-3 and Figure 3-3 present the duration factors established for each regional station and for the site.

Table 3-3: Regional Analysis of Duration Factors

Station ID	Long.	Lat.	Elev. masl	Dist, km	Storm Duration								
					6 min	10 min	30 min	1 hr	2 hr	3 hr	6 hr	12 hr	24 hr
Mayo A	-135.87	63.62	503.80	131.10	0.20	0.26	0.29	0.34	0.37	0.45	0.61	0.78	1.00
Pelly Ranch	-137.37	62.82	454.20	23.45	0.23	0.32	0.40	0.48	0.58	0.66	0.75	0.85	1.00
Dawson A	-139.13	64.04	370.30	184.33	0.30	0.38	0.42	0.51	0.57	0.65	0.72	0.87	1.00
Carmacks	-136.30	62.10	524.90	75.35	0.24	0.34	0.40	0.47	0.52	0.60	0.72	0.89	1.00
Burwash A	-139.05	61.37	806.20	168.10	0.09	0.13	0.16	0.21	0.28	0.34	0.65	0.77	1.00
Site Estimated	-137.22	62.62	784.45	n/a	0.24	0.32	0.38	0.45	0.52	0.59	0.70	0.85	1.00

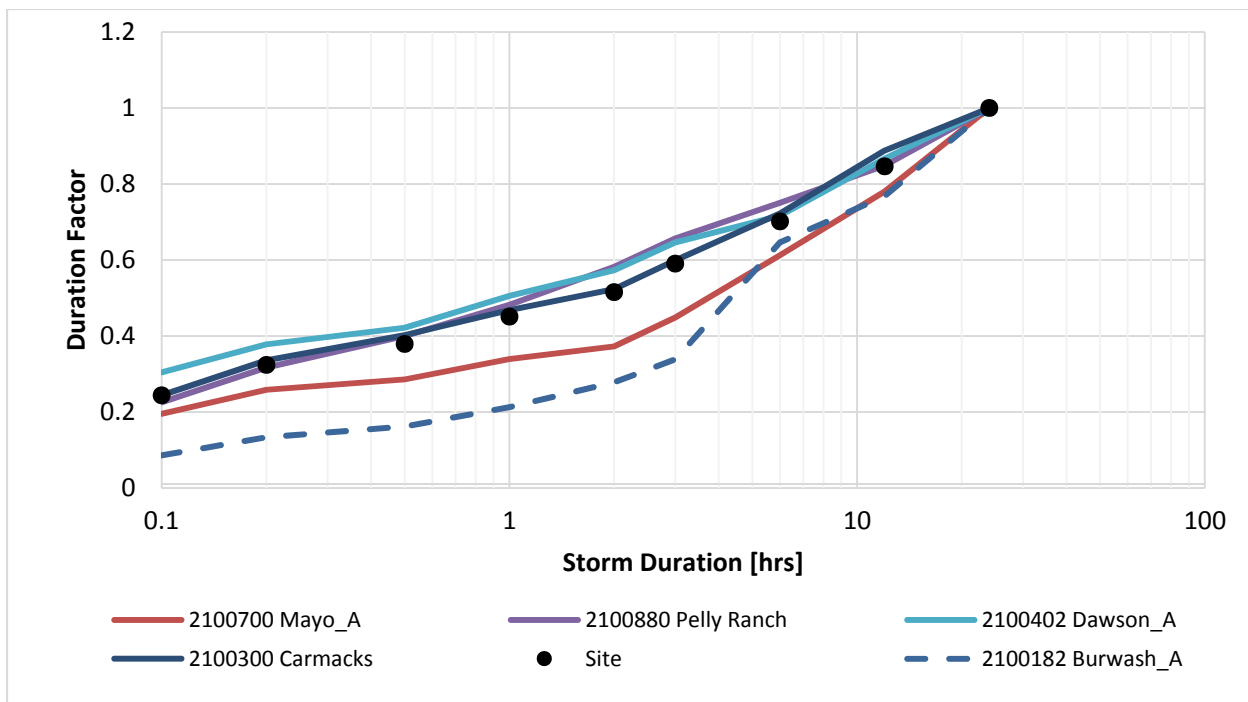

Figure 3-3: Regional and Site-Specific Duration Factors

Regional Trends in Frequency Factors

Similarly to the duration factors, the Pearson distribution was used to determine whether the frequency factors for each return period were related to the elevation, latitude, or longitude of the meteorological station. The best relationship was found to be with elevation; however, the difference in frequency factors across the region was minimal, and the site elevation was within the range of the stations analyzed. Therefore, the average from the regional frequency factors was applied to the site. Table 3-4 and Figure 3-4 present the duration factors established for each regional station and for the site.

Table 3-4: Regional Analysis of Frequency Factors

Station ID	Long. [degrees]	Lat. [degrees]	Elevation [masl]	Distance [km]	Return Period [years]					
					2	5	10	25	50	100
Mayo A	-135.87	63.62	503.80	131.10	0.70	0.88	1.00	1.15	1.26	1.37
Pelly Ranch	-137.37	62.82	454.20	23.45	0.58	0.83	1.00	1.19	1.34	1.49
Dawson A	-139.13	64.04	370.30	184.33	0.65	0.85	1.00	1.15	1.28	1.40
Carmacks	-136.30	62.10	524.90	75.35	0.64	0.85	1.00	1.17	1.30	1.43
Burwash A	-139.05	61.37	806.20	168.10	0.71	0.89	1.00	1.15	1.26	1.36
Site (Estimated)	-137.22	62.62	784.45	n/a	0.66	0.86	1.00	1.16	1.29	1.41

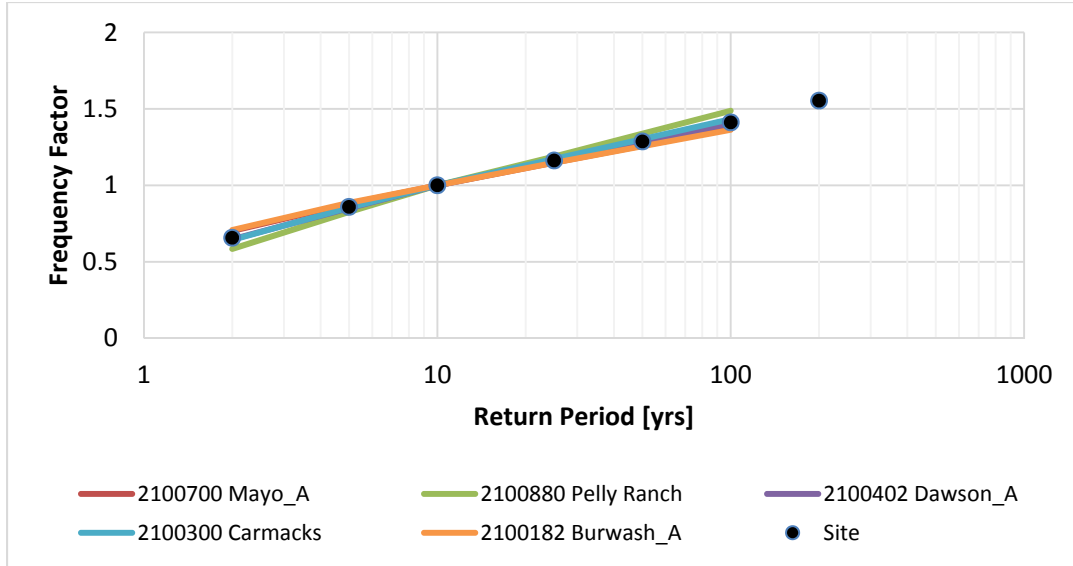

Figure 3-4: Regional and Site-Specific Frequency Factors

3.2.3 Site-Specific Intensity-Duration-Frequency Table

The results of site-specific frequency and duration factors and the 1:10 year, 24-hour duration rainfall of 34.2 mm were converted to an IDF table using Equation 1. In addition, the 1:200 year rainfall depth was extrapolated for each duration using a linear extrapolation of the duration factors and frequency factors. Results are presented in Table 3-5.

Table 3-5: Site-Specific IDF Table

Storm Duration		Return Period [years]						
Minutes	Hours	2	5	10	25	50	100	200
5	0.08	5.5	7.2	8.3	9.7	10.7	11.8	13.0
10	0.17	7.3	9.5	11.1	12.9	14.3	15.6	17.2
15	0.25	8.5	11.2	13.0	15.1	16.7	18.3	20.2
30	0.5	10.1	13.3	15.4	17.9	19.9	21.8	24.0
60	1	11.6	15.2	17.6	20.5	22.7	24.9	27.4
120	2	13.3	17.4	20.2	23.5	26.0	28.5	31.4
360	6	15.8	20.6	24.0	27.9	30.9	33.9	37.3
720	12	19.0	24.9	29.0	33.6	37.3	40.9	45.0
1440	24	23.5	30.0	34.2	39.3	42.9	46.6	47.6

3.2.4 Climate Change and IDF Results

The values for the respective return periods and durations were increased by 44% to reflect the forecasted increase resulting from the effects of future climate change (SRK 2016). Adjusted IDF values are presented in Table 3-6.

Table 3-6: Site-Specific IDF Table Adjusted for Total Precipitation Increase by 2100

Storm Duration		Return Periods [years]						
Minutes	Hours	2	5	10	25	50	100	200
5	0.08	7.9	10.3	12.0	14.0	15.5	17.0	18.7
10	0.17	10.5	13.7	16.0	18.5	20.5	22.5	24.8
15	0.25	12.3	16.1	18.7	21.7	24.0	26.4	29.0
30	0.5	14.6	19.1	22.2	25.8	28.6	31.4	34.5
60	1	16.7	21.8	25.4	29.5	32.7	35.8	39.5
120	2	19.1	25.0	29.1	33.8	37.4	41.1	45.2
360	6	22.7	29.7	34.6	40.2	44.5	48.8	53.7
720	12	27.4	35.8	41.7	48.5	53.7	58.9	64.8
1440	24	33.8	43.2	49.2	56.6	61.8	67.1	68.5

3.3 Snowmelt

Snowmelt estimation was performed in RStudio software using a daily snowmelt-energy model. This model incorporates daily meteorological parameters including daily maximum and minimum temperatures, wind speed, and total precipitation. Daily values for each parameter were obtained using the ERA-Interim reanalysis tool with daily information from 1979 to 2015 (ECMWF 2015).

Using the energy-based model (Walter 2005), the snow-water equivalent, potential snowmelt, and snowpack depth were calculated at each time step. The maximum daily snowmelt for each month of the simulated record from ERA-Interim was calculated, and the 50th percentile of maximum daily snowmelt was determined to be 23 mm/day (SRK 2016). This value can be applied as a baseflow on top of the design storm to estimate true peak flows for each catchment.

3.4 Probable Maximum Precipitation

The PMP for a 24-hour duration event was evaluated using the Hershfield method (World Meteorological Organization (WMO), 2009), for the same 20 regional meteorological stations used in the analysis for MAP. The Hershfield methodology requires the daily maximum 24 hour precipitation for at least 10 years of record. The analysis was performed in RStudio software, generating a PMP estimate for each of the 20 regional stations. A regression analysis was performed against longitude, which was found to have a better correlation than latitude or elevation. The results are presented in Figure 3-5, which presents a 24-hour PMP for the site of 159 mm.

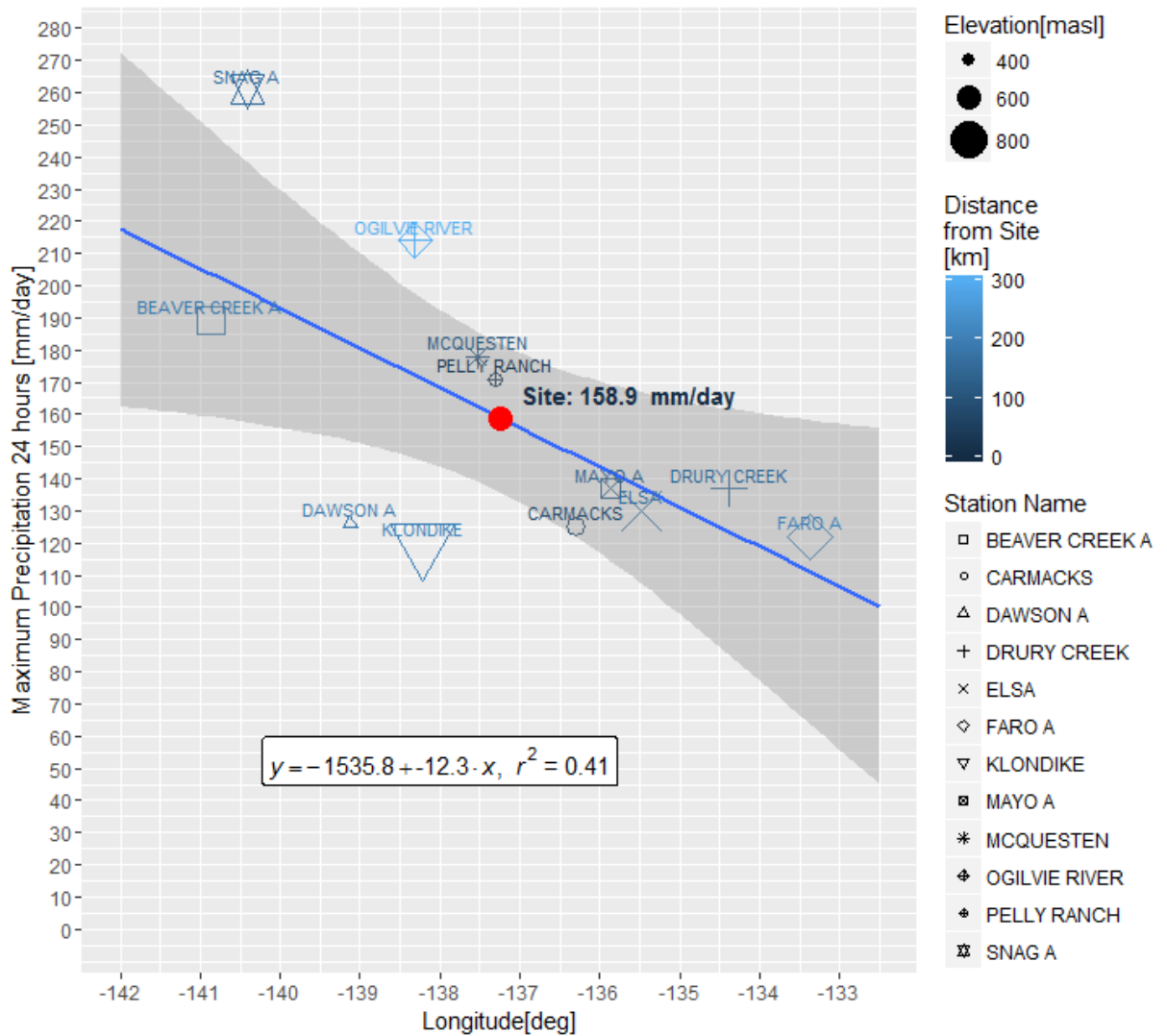

Figure 3-5: Regional Analysis for PMP

4 Peak Flows

A rainfall-runoff approach was used to model peak flows at the site. Rainfall was applied to 24-hour distribution curve and was then converted to runoff based on catchment characteristics, including curve number, lag time, and total area, using the Soil Conservation Service (SCS) Method.

A HEC-HMS (2013) model was developed to model the mine site region in closure.

4.1 Frequency-based Hypothetical Storm

The depth and temporal distribution of the storm hyetograph was defined using synthetic 24-hour rainfall distributions developed by National Resource Conservation Service (NRCS) (Chow et al. 1988), with a Type 1 rainfall distribution. This was selected due to the Pacific maritime climate with wet winters and dry summers observed in the Yukon, which closely mirrors the climate within Alaska for which a Type 1 distribution is typical (Chow et al. 1988). This distribution approximates an intense, short-duration storm event.

4.2 Initial loss

The SCS curve number model was used to estimate precipitation excess as a function of cumulative precipitation, soil cover, land use and antecedent moisture using the following equation:

$$P_e = \frac{(P - I_a)}{P - I_a + S}$$

Where,

P_e = accumulated precipitation excess at time t ,

P = accumulated rainfall depth at time t ,

I_a = the initial abstraction (initial loss), and

S = potential maximum retention, a measure of the ability of a watershed to abstract and retain storm precipitation.

An empirical relationship between I_a and S was developed by the SCS as:

$$I_a = 0.2S$$

The maximum retention, S , and watershed characteristics related through an intermediate parameter, the curve number was developed as:

$$S = \frac{25400 - 254 CN}{CN}$$

Incremental excess for a time interval is computed as the difference between the accumulated excess at the end of and beginning of the period.

4.3 Hydrological Transformations

The SCS Unit Hydrograph method was used to transform precipitation excess into an outflow hydrograph for each sub-area. HEC-HMS (2013) uses a single input parameter, the lag time (T_{lag}), defined as the time between the centroid of precipitation mass to the peak for the resulting hydrograph. The lag time for each catchment was calculated using the NRCS transformation from

time of concentration. The NRCS transformation is $T_{lag} = 0.6 \cdot T_c$. Time of concentration and resulting lag times are relatively short (<15 minutes), resulting in a flashy response with peak discharge timing almost coincident with the timing of the precipitation peak. The time of concentration was estimated with the methods cited in (Li *et al.* 2008). A minimum time of concentration of 10 minutes was applied to all catchments. The resulting lag time for each catchment is presented in Table 4-3.

4.4 Model Inputs

Individual infrastructure entities were allotted a contributing catchment, which was characterized based on its average slope, longest path from highest point to lowest point, curve number, and area.

4.4.1 Catchment Delineations

Catchment characteristics (including areas, slopes and longest path) were determined in Global Mapper™ (Blue Marble Geographic 2016), using projected contour information for closure (Geobase 1:25k).

Catchments were connected and routed to the pits, and ultimately to Minto Creek. Each pit was assumed to be full of water at the time of the peak flow event. The catchments are presented in Figure 4-1 and Figure 4-2.

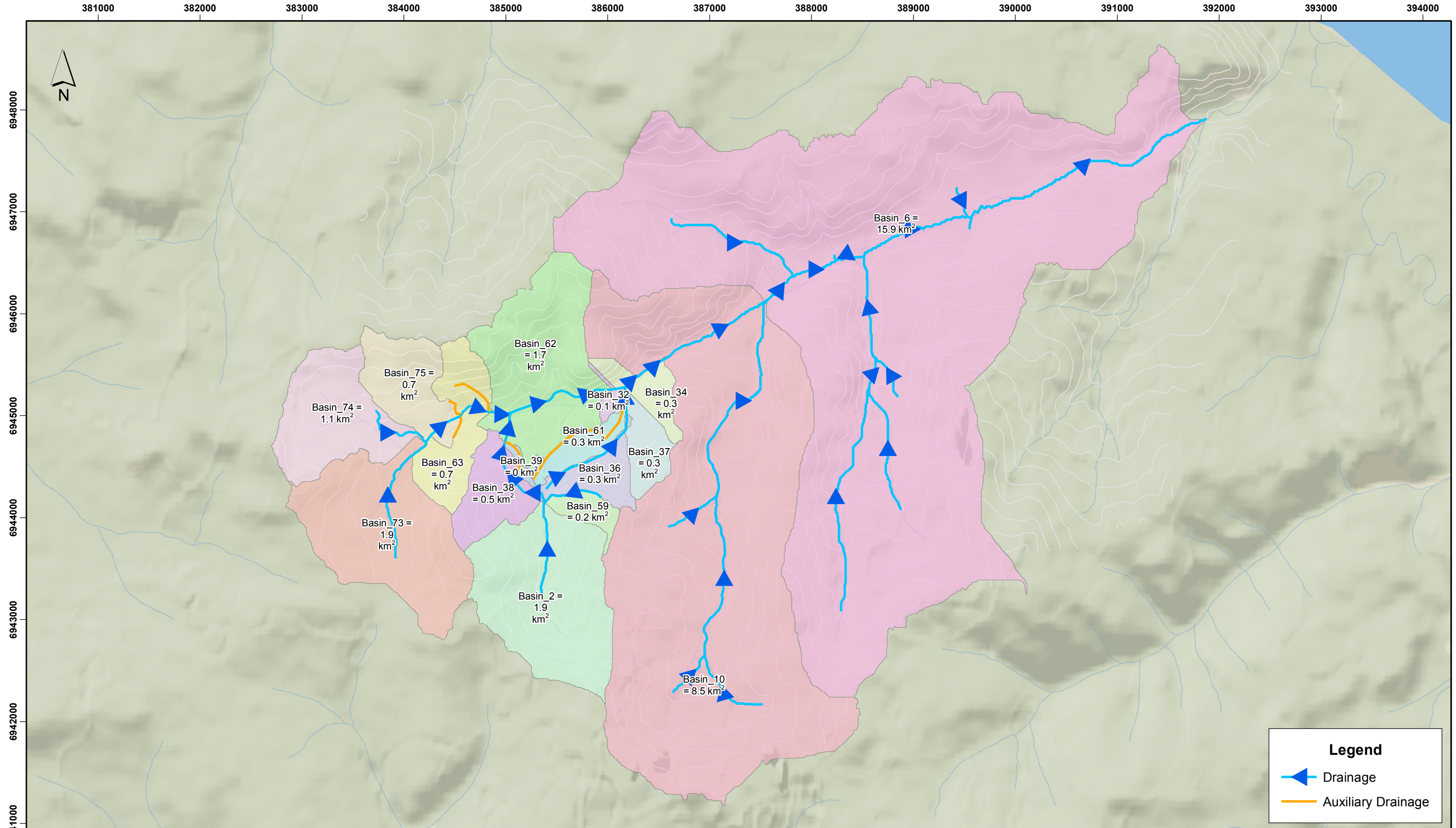

Legend

- ← Drainage
- Auxiliary Drainage

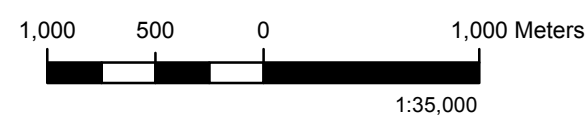

Notes:
 1. Data presented in NAD 1983 UTM Zone 8N.
 2. Contours in 1 m intervals.



Site-Specific Hydrology Review

Watershed ID's and Areas

Job No: 1CM002.042
 Filename: Fig2_PostClosure_WaterManagement.mxd

Minto Explorations Ltd.

Date: August 2016	Approved: VM	Figure: 4-1
----------------------	-----------------	-----------------------

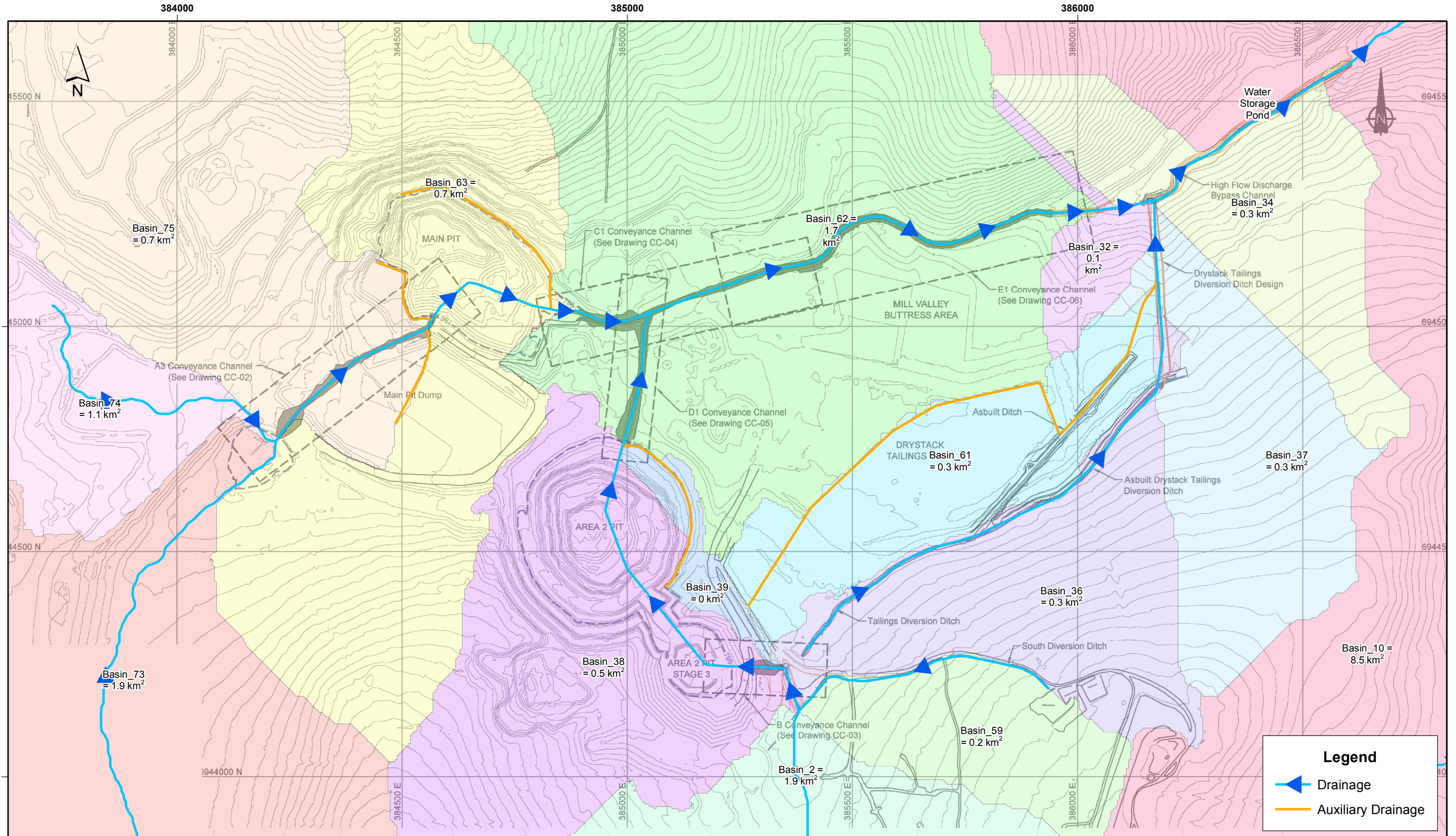

Legend

- Drainage
- Auxiliary Drainage

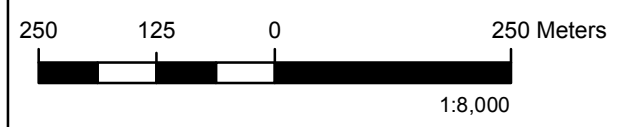

Notes:
 1. Data presented in NAD 1983 UTM Zone 8N.
 2. Contours in 1 m intervals.



Job No: 1CM002.042
 Filename: Fig1_PostClosure_WaterManagement.mxd



Minto Explorations Ltd.

Site-Specific Hydrology Review		
Conveyance Channel System and West Watersheds		
Date: August 2016	Approved: VM	Figure: 4-2

4.4.2 Curve Number

The SCS curve number is utilized for the calculation of precipitation excess and the transformation of runoff within the watershed (NRCS 1986). The curve number for a watershed can be estimated as a function of land use, soil type, and antecedent watershed moisture, using tables published by the SCS and refined using calibration methods.

Once the closure period begins, the active mining areas will be decommissioned, and the land use is assumed to return to natural conditions. Based on this assumption, the curve number for the site can be calibrated using a regional catchment with known peak flows, a rainfall depth, and catchment characteristics including lag time and area.

A suitable regional catchment was selected using a regional analysis, comparing unit peak flows for eight nearby WSC hydrometric stations (EC 2015b). The stations are summarized in Table 4-1 (EC 2015b) and were compiled in RStudio software.

Table 4-1: Summary of Water Survey of Canada Stations used in Regional Analysis of Peak Flows

Station Name	Lat. [degrees]	Long [degrees]	Area [km ²]	Distance from Site [km]	Years with Info.
DRURY CREEK AT KM 469 ROBERT CAMPBELL HIGHWAY	62.2	-134.4	552	154	15
LITTLE SOUTH KLONDIKE RIVER BELOW ROSS CREEK	64.0	-137.6	860	154	13
GILTANA CREEK NEAR THE MOUTH	61.2	-137.0	190	159	27
SOUTH BIG SALMON RIVER BELOW LIVINGSTONE CREEK	61.4	-134.4	515	203	14
IBEX RIVER NEAR WHITEHORSE	60.7	-135.5	648	230	23
SIDNEY CREEK AT KILOMETRE 46 SOUTH CANOL ROAD	60.8	-133.1	372	301	12
WHEATON RIVER NEAR CARCROSS	60.1	-134.9	864	304	48
SOUTH MACMILLAN RIVER AT KILOMETRE 407 CANOL ROAD	62.9	-130.5	997	343	22
PINE CREEK NEAR ATLIN	59.6	-133.7	697	391	11

Peak and unit peak flows were calculated for return periods between the 1:2 year and 1:200 year events, where the unit peak flow is equal to the peak flow divided by the catchment area.

Relationships were developed for unit peak flows of each return period and longitude, elevation and latitude. The best correlation was found to be with latitude, and the results of the regression analyses are presented in Figure 4-3.

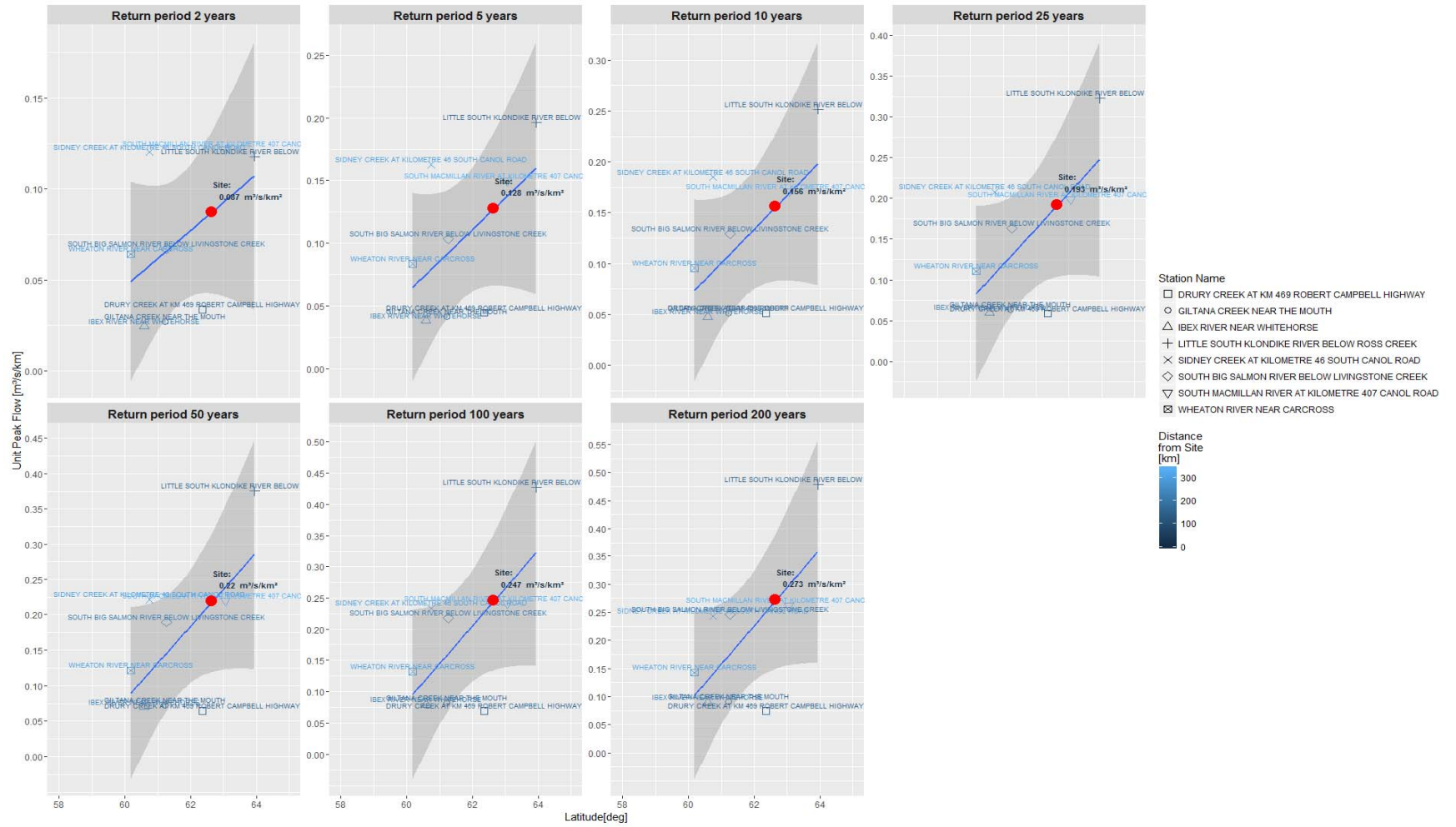

Figure 4-3: Regional Unit Peak Flows

For return periods greater than the 1:5 year event, the Little South Klondike River below Ross Creek presents the highest unit peak. For this reason, the Little South Klondike River below Ross Creek hydrometric station was selected for curve number calibration purposes to generate a conservatively high estimate.

The lag time for Little South Klondike River below Ross Creek was calculated to be 137 minutes, using the methodology described in Section 4.3 and was modelled in HEC-HMS (2013) along with the catchment area. Rainfall depths from the IDF results in Table 3-5 prior to climate change impacts were modelled for the 1:200 year event and the 1:10 year event, which form the design criteria for the closure conveyance structures. The curve number value was adjusted until the modelled peak flows matched the historically estimated peak flows. The results of the calibration are presented in Table 4-2, and include varying the curve number value from 70 to 84.

Table 4-2: Curve Number Calibration Results

Return Period [years]	Historic Rainfall Depth [mm]	Historic Peak Flow [m ³ /s]	Curve Number					
			70	75	80	82	83	84
200	47.6	411.7	91.4	172.1	311.3	385.2	425.6	468.6
10	34.2	216.3	27.8	53	111.4	151	175.1	201.6

The 1:200 year return period was best matched using a curve number value of 83. The peak flow for the 1:10 year event using this curve number value is underestimated. However this return period is only used for the sizing of pilot channels within larger floodplain channels, ensuring that any overtopping of the pilot channel as a result of slightly underestimated flows will be captured. The curve number value of 83 was applied to all site catchments for closure conditions.

4.4.3 Snowmelt Baseflow

The snowmelt depth calculated in Section 3.3 was multiplied by each catchment area to establish snowmelt flow. This flow was added as a constant baseflow to each catchment in HEC-HMS (2013).

A summary of the site catchment delineations, including individual curve numbers, snowmelt and calculated lag time, are presented in Table 4-3.

Table 4-3: Catchment Characteristics for Input into Hydrologic Model

Catchment ID	Area [km ²]	Curve Number	Lag Time [min]	Snowmelt Baseflow [m ³ /s]
14B	8.53	83	31.14	2.07
38B	0.06	83	6.00	0.02
40B	0.29	83	9.77	0.07
42B	0.34	83	12.28	0.08
43B	0.32	83	11.71	0.08

Catchment ID	Area [km ²]	Curve Number	Lag Time [min]	Snowmelt Baseflow [m ³ /s]
44B	0.55	83	11.04	0.13
45B	0.04	83	7.96	0.01
5B	1.89	83	17.56	0.46
61B	0.18	83	11.54	0.04
63B	0.25	83	14.76	0.06
65B	1.73	83	13.87	0.42
66B	0.69	83	12.59	0.17
76B	1.90	83	20.88	0.46
77B	1.11	83	18.22	0.27
78B	0.70	83	12.98	0.17
9B	15.90	83	41.31	3.87

4.5 Model Results

Using the input parameters listed in Table 4-3, peak flows were calculated in the HEC-HMS (2013) model. The results are summarized in Table 4-4 for each flow condition.

Table 4-4: Resultant Peak Flows

Element ID	Peak flow (m ³ /s)			
	1:2 year	1:10 year	1:200 year	PMP
10C	3.8	8.4	15.4	56.1
10R	3.8	8.2	15.3	55.4
12C	7.2	15.4	28.9	110.2
12R	7.2	15.3	28.8	109.1
13C	2.3	5.1	9.5	34.3
13R	2.3	5	9.4	33.8
14B	6.6	14.1	25.8	92.1
14C	2.7	6.1	11.3	40.5
14R	2.7	6.1	11.3	40.5
32C	3.4	7.6	14.1	50.5
32R	3.3	7.4	13.6	48.7
38B	0.5	0.5	0.5	1.3
4C	2	4.4	8.2	29.3
4R	2	4.4	8.1	28.7
40B	0.3	0.8	1.4	4.9
42B	0.4	0.8	1.6	5.7
43B	0.3	0.8	1.5	5.3

Element ID	Peak flow (m ³ /s)			
	1:2 year	1:10 year	1:200 year	PMP
44B	0.6	1.4	2.6	9.3
45B	0.1	0.1	0.2	0.8
5B	1.8	4.1	7.5	26.9
5C	7.1	15.3	28.7	109.2
5R	7.1	15.2	28.5	108.6
6C	19.6	39.1	73.3	303
61B	0.2	0.5	0.8	3
63B	2.1	2.1	2.1	3.9
65B	1.8	4	7.6	27.5
66B	0.7	1.7	3.2	11.4
7C	11.7	24.5	47.1	193.6
7R	11.7	24.3	47	192.7
76B	1.7	3.7	6.9	24.9
77B	1	2.3	4.4	15.6
78B	0.7	1.7	3.2	11.4
8C	6.7	14.4	27.2	101.9
8R	6.6	14.3	26.9	101
9B	11.2	23.2	41.9	147.6
9C	2.1	2.1	2.7	9.6
9R	2.1	2.1	2.5	9.3

5 Summary

A hydrologic study was performed for the closure period at the Minto Mine to design closure conveyance structures. The study used regional meteorological stations to generate expected precipitation estimates for the site. Precipitation results were then included in a hydrologic model for the site, based on closure conditions.

The following is a summary of the design criteria for conveyance channels:

- Mean annual precipitation of 395 mm;
- The intensity-duration-frequency results are adjusted for potential impacts due to climate change, for a range of storm durations and frequencies (Table 3-6)
 - 1:200 year 24-hour rainfall depth of 68.5 mm,
 - 1:10 year 24-hour rainfall depth of 49.2 mm;

- Maximum expected 24-hour snowmelt depth of 23 mm including the impacts of climate change;
- 24-hour probable maximum precipitation (PMP) of 159 mm;
- Site catchment delineation used for closure conveyance infrastructure is illustrated in Figure 4-1a and 4-1b; and
- Calibrated regional curve number for natural catchments is a value of 83.

SRK Consulting (Canada) Inc.

Original Signed By

Samantha Barnes, EIT

Original Signed By

Victor Muñoz S., MEng, PEng.

Original Signed By

Francis Smith, EIT

and reviewed by

Original Signed By

Dylan McGregor, MAsc, PGeo.

Disclaimer—SRK Consulting (Canada) Inc. has prepared this document for Minto Explorations Ltd. Any use or decisions by which a third party makes of this document are the responsibility of such third parties. In no circumstance does SRK accept any consequential liability arising from commercial decisions or actions resulting from the use of this report by a third party.

The opinions expressed in this report have been based on the information available to SRK at the time of preparation. SRK has exercised all due care in reviewing information supplied by others for use on this project. Whilst SRK has compared key supplied data with expected values, the accuracy of the results and conclusions from the review are entirely reliant on the accuracy and completeness of the supplied data. SRK does not accept responsibility for any errors or omissions in the supplied information, except to the extent that SRK was hired to verify the data.

6 References

- Blue Marble Geographic. 2016. Global Mapper Version 16.
- Chow, Ven, David Maidment, and Larry Mays. 1988. Applied Hydrology. McGraw-Hill.
- [ECMWF] European Centre for Medium-Range Weather Forecasts. 2015. ERA-Interim. Retrieved from: <http://www.ecmwf.int/en/research/climate-reanalysis/era-interim>
- [EC] Environment Canada. (2015a). Meteorological Service of Canada.
- [EC] Environment Canada. (2015b). Water Survey of Canada.
- Government of Canada. 2016. "Engineering Climate Datasets." 07. Accessed 07 2016. http://climate.weather.gc.ca/prods_servs/engineering_e.html.
- HEC-HMS. 2013. Hydrologic Modeling System Version 4.0. Developed for the U.S. Army Corps of Engineers.
- Laio F, Di Baldassarre G, and Montanari A. 2009. Model selection techniques for the frequency analysis of hydrological extremes. Water Resources Research, 45.
- Li, M. et al. 2008. Overland Flow Time of Concentration on Very Flat Terrains. Journal of the Transportation Research Board, 2060.
- [NRCS] Natural Resources Conservation Service. (1986). Urban Hydrology for Small Watersheds, TR-55. United States Department of Agriculture,.
- SRK Consulting. 2016. Minto Mine Climate Change Analysis.
- Walter MT, et al. 2005. Process-based Snowmelt Modeling: Does it Require More Input Data than Temperature-Index Modeling? Journal of Hydrology, 65-75.
- [WMO] World Meteorological Organization. 2009. Manual on Estimation of Probable Maximum Precipitation. Geneva.

Appendix C – Climate Change Analysis

Memo

To:	Ryan Herbert, Minto Explorations Ltd.	Client:	Minto Explorations Ltd.
From:	Victor Munoz Saavedra Tia Shapka-Fels	Project No:	1CM002.042
Cc:	Dylan McGregor, SRK	Date:	August 3, 2016
Subject:	Climate Change Analysis, Minto Mine, Yukon		

1 Introduction

SRK Consulting (Canada) Inc. has prepared an updated closure water conveyance plan design report for Minto Mine (Minto) located in the Yukon, Canada, and operated by Minto Exploration Ltd.

There is agreement within the engineering community that climate change is occurring and that climate change needs to be integrated into engineering designs. Engineers Canada (2013) encourages its members to keep themselves informed about the changing climate and consider potential impacts on their professional activities. Design integration of climate change analysis results looks to the long term performance of mine closure designs such as conveyance channels and waste rock cover systems. Mine closure infrastructure designed using average daily temperatures and precipitation values during mines operation may not be adequate for infrastructures that support the mine site in the future when the climate has changed.

This memo presents climate change projections of key climatic and hydrological parameters which may be experienced at the mine site in the future. Parameters include, but are not limited to, projections for changes in temperature, rain and snowfall precipitation. This memo further discusses how the climate change projections for the Minto site are then integrated into the closure conveyance channel design.

2 Method

Climate change analysis includes collating and evaluating baseline climate data, querying available climate change prediction models, and making forecasting climate trends. This analysis produced a graphical summary of results (Section 5). The summaries presented in Section 5 are a probabilistic expected change in the climatic with respect to baseline conditions at the Minto mine site.

The analysis required three steps as outlined in Section 2.1 to 2.3.

2.1 Step 1: Data Retrieval

The first step of the analysis was to identify the availability of the climate change models for each required climate parameter. Environment Canada provides access to monthly climate change modeling predictions for any location in the World from the following climate change assessment reports:

- Canadian Regional Climate Model (CRCM), also called First Assessment Report (AR1) (EC 2015)
- Second Assessment Report (AR2) (IPCC 1995)
- Third Assessment Report (AR3) (IPCC 2001)
- Fourth Assessment Report (AR4) (IPCC 2007)
- Fifth Assessment Report (AR5) (IPCC 2014)

Information for the first four assessment reports is available from 1960, with predictions out to 2100 for the meteorological variables listed in Table 2.1; however, there are significant gaps depending on the assessment report, scenario evaluated, and variable assessed. Information for the fifth assessment report is available for 1900 to 2100, but only includes mean temperature and total precipitation.

As part of the procedure, data from the five assessment reports are downloaded from Environment Canada for the site being evaluated based on latitude and longitude. This process is automated through a purpose built script developed using R programming language (CRAN 2015).

The meteorological parameters covered in the assessment reports are used, though application of empirical models, to calculate climate change design parameters for other parameters such as intensity-duration–frequency (IDF) curves (i.e. extreme storm events), snowpack thickness, evaporation, etc.

Table 2.1: Metrological Parameters Listed in AR1 through AR4

Parameter	Base Parameter	Details
Air Temperature	Temperature	Mean (T_{mean}), Mean Max (T_{max}), Mean Minimum (T_{min}), and Extreme Range at 2 m above ground surface
Heat Wave Duration Index	Temperature	Maximum period >5 consecutive days with $T_{\text{max}} > 5^{\circ}\text{C}$ above the baseline T_{max} normal
Frost Days	Temperature	Total number of frost days (days with absolute minimum temperature $< 0^{\circ}\text{C}$)
Growing Season Length (GSL)	Temperature	Growing season length is defined as the time period each year between when $T_{\text{mean}} > 5^{\circ}\text{C}$ for more than 5 days and when $T_{\text{mean}} < 5^{\circ}\text{C}$ for more than 5 days
Air Temp. Extreme Range	Temperature	Intra-annual extreme temperature range is the difference between the highest temperature and lowest temperature of the same calendar year

Parameter	Base Parameter	Details
Total Precipitation	Precipitation	Total precipitation including rainfall and snowfall as snow water equivalent
Days with rain >10 mm	Precipitation	Days with rain greater than or equal to 10 mm/day
Simple Daily Intensity Index	Precipitation	Annual total precipitation divided by the number of precipitation days greater than or equal to 1 mm/day
Dry Days	Precipitation	Max amount of consecutives dry days (precipitation <1 mm)
Fraction of total annual precipitation >95 th percentile	Precipitation	Annual precipitation >95th percentile
Wind Speed	Wind Speed	Mean, Meridional, and Zonal wind speed at 10 m above ground surface
Solar Radiation	Radiation	Shortwave surface down-welling
Humidity	Humidity	Relative and specific humidity at 2 m above ground surface
Sea Level Pressure	Air Pressure	Mean sea level pressure

2.2 Step 2: Baseline Analysis (Outcome 1)

Climate change models presented in the assessment reports assume application of radiative forces (energy flux) through different anthropogenic sources that results in discharge of varying concentrations of atmospheric greenhouse gases. These radiative forces are not constant through time, as they are based on global anthropogenic behavior such as environmental policies, population growth, economic growth, energy sources, land use, hydrocarbon usage, etc. Each individual climate change model presented in the assessment reports represent these non-linear radiative forces differently and thus present a different climate change scenario, underscored by its own model assumptions and boundary conditions.

None of these individual models are inherently superior or inferior to others, and likewise, the newer generation of assessment reports are not necessarily more reliable than older versions, but rather represent more detailed consideration of global anthropogenic forces. Therefore, the user is forced to make a judgement call on which individual model or generation of models are the most suitable to use in design, which invariably leads to bias. This method of analysis is specifically aimed at eliminating this bias by analysing all the available climate change models with equal weight and presenting a single climate change design parameter based on a rational statistical evaluation of the overall cumulative results.

Using each and every climate change model available in the five assessment reports, the projected change with respect to a set baseline condition can be calculated using Equation 2.1.

Equation 2.1

$$\text{Change with respect to set baseline condition [\%]} = \frac{\text{Projection} - \text{Baseline}}{\text{Baseline}}$$

In Equation 2.1, the *Baseline* and *Projection* periods have a minimum timeframe of 30 years, which is generally recognized as being the minimum acceptable period length of record that is statistically significant (WMO 2007). These periods can be defined as follows:

- *Baseline* is the time frame associated with the past (i.e. estimation of the climate data based on the climate change models). For the purpose of this analysis, this period is fixed from 1975 to 2005, which coincides with the baseline adopted for AR5.
- *Projection* is the future time frame where climate change models are applied, reflecting climate change predictions. Three *Projection* periods are applied from 2011 to 2040, 2041 to 2070, and 2071 to 2100. These 30-year periods are based on convention as stipulated in WMO (2007).

Climate change model predictions are currently presented up to the year 2100 (IPCC 2014), which is deemed that maximum reasonable timeframe to extend predictions to. As a result, this is the maximum timeframe for which this analysis method applies.

Equation 2.1 is automatically processed using a script developed in R. An example result is presented in Figure 2.1, which represents the outcome at a hypothetical site for the meteorological parameter mean air temperature. For this example, the *Projection* period is representative of 2041 to 2070.

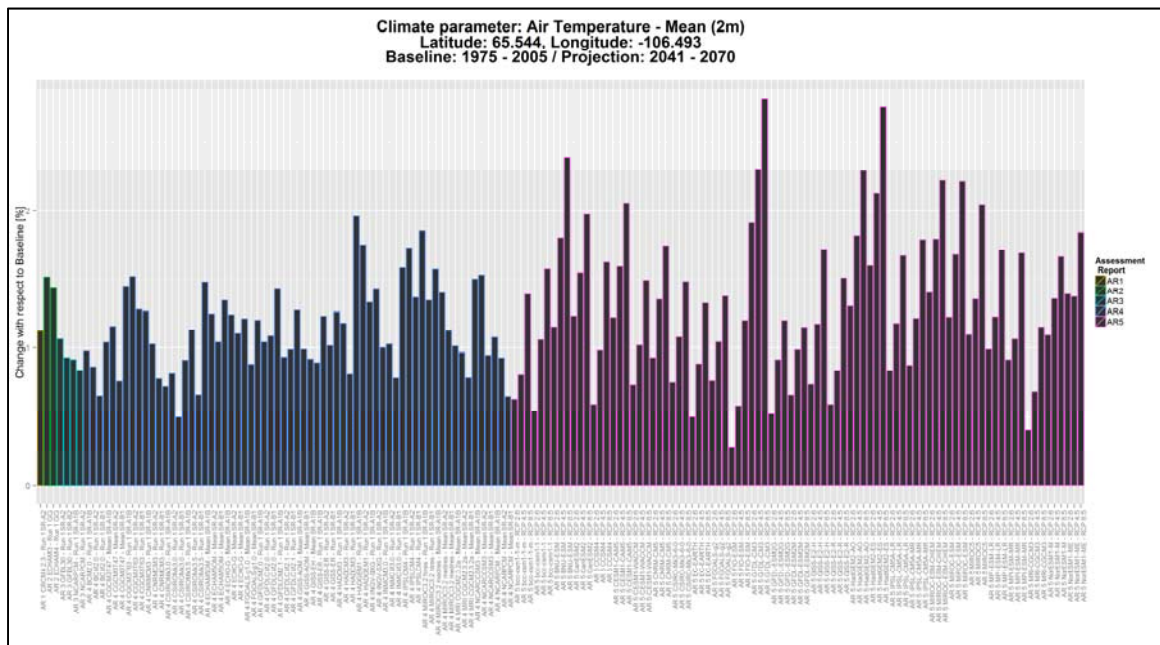

Figure 2.1: Example outcome for hypothetical site showing results of change to baseline conditions for individual climate change models associated with each of the five assessment reports for a projection period from 2041 to 2070

The analysis presented in Figure 2.1 can be presented as a box-whisker plot as illustrated in Figure 2.2. The change with respect to baseline conditions for each individual Assessment Report is summarized, together with an overall summary representing all the assessment reports combined. The centerline of the box represents the median value, while the upper and lower box borders represent the first and third quartile values, respectively. The limits whiskers will extend to the maximum and minimum of 1.5 times the total range of the box (i.e. the third quartile minus first quartile). If values exist outside the whisker limits (i.e. outliers), then they are presented as dots.

The results in Figure 2.2 can also be presented as a cumulative probabilistic curve as illustrated in Figure 2.3. To weigh all climate change models equally, only the cumulative probabilistic curve associated with combined data from all assessment reports was considered in this analysis. The overall spread of results as presented by the collection of box-whisker plots in Figure 2.2 illustrates why this is deemed appropriate.

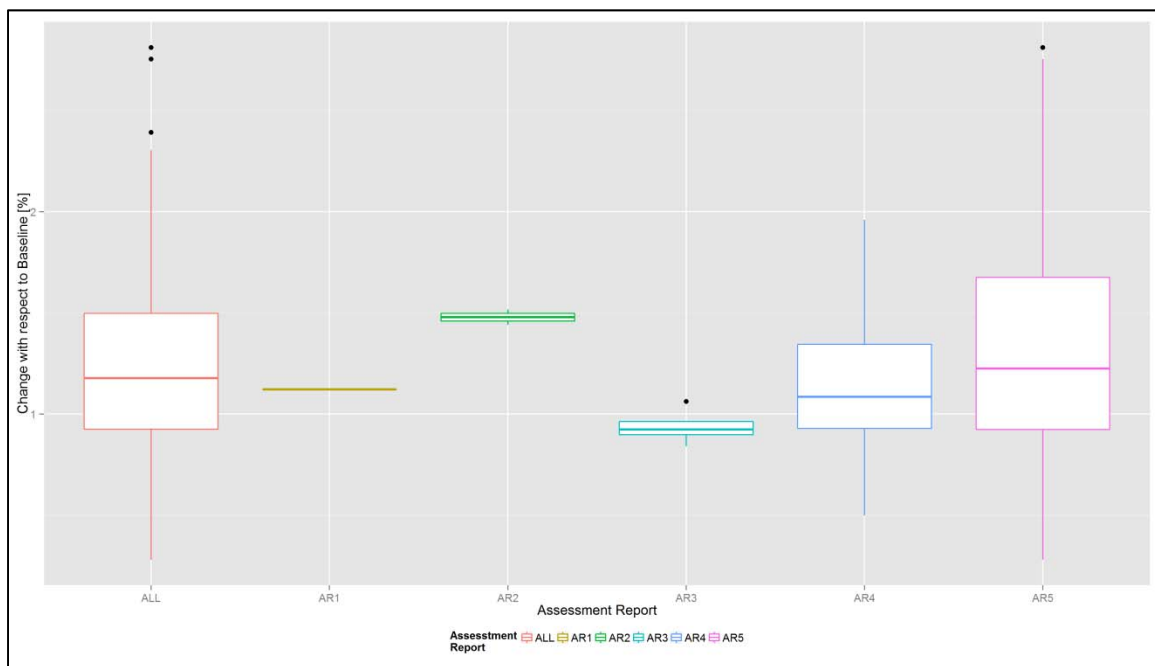

Figure 2.2: Combined box-whisker plot of change to baseline conditions for the individual climate change models presented in the Figure 2.1 example

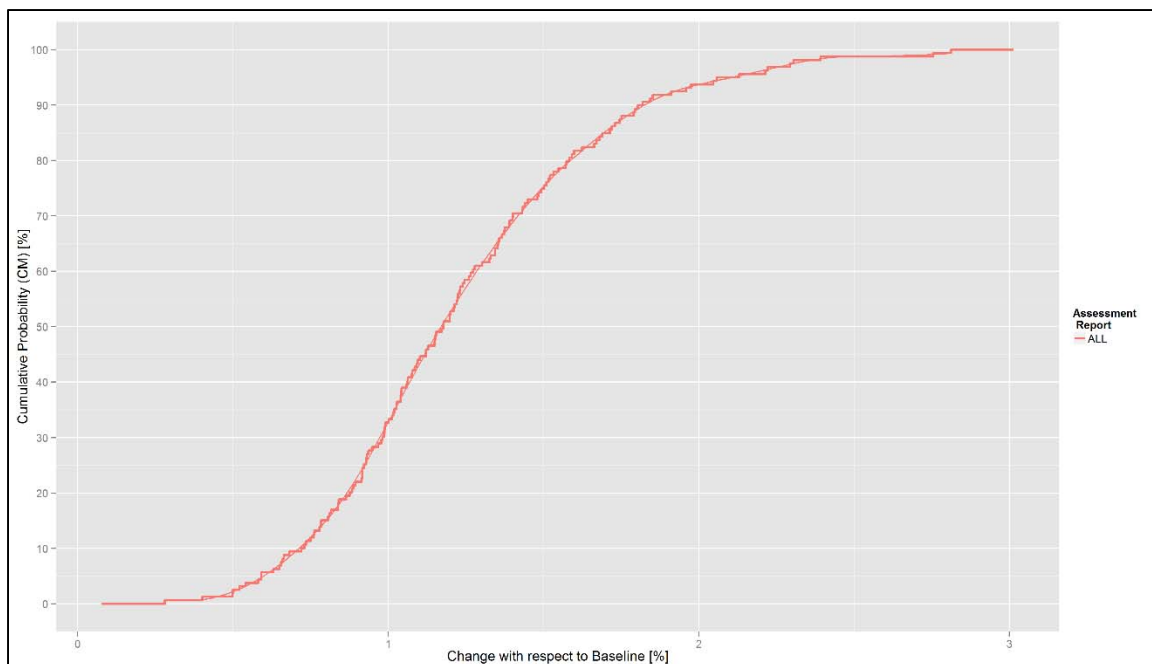

Figure 2.3: Cumulative probability curve of climate change prediction models from all assessment reports expressed as a percentage of change against baseline conditions

2.3 Step 3: Trend Analysis (Outcome 2)

As discussed in Section 2.2, climate change models consider global anthropogenic forces that are not constant in time. Irrespective of such forces, the science of hydrology estimates and predicts future meteorological conditions through consideration of historic trends. Therefore, to facilitate selection of climate change parameters for design, a trend analysis approach is used as a reality check.

To best represent the historical trend, a global climatic model reanalysis approach is used, rather than relying on regional meteorological stations for historic data, since the availability and timespan of records vary greatly. Reanalysis combines satellite information, land records, and numerical models that simulate the earth's climatic conditions. Typically, reanalysis extends for several decades and covers the entire planet. State-of-the-art publically available reanalysis data from ERA-Interim produced by the European Center for Medium-Range Weather Forecast (ECMWF 2015) was used in this analysis. ERA-Interim includes twice daily data from 1979 to 2015 for the entire world, based on a 0.75 degree latitude by 0.75 degree longitude grid.

The ERA-Interim data trend analysis entailed two parts: first, identification of the trend, and second, estimation of the statistical significance of the trend. Five different trend analysis methodologies were considered:

- Ordinary least square (Maidment 1993)
- Quantile regression (Koenker and Bassett 1978)

- Mann-Kendall and Theil Sen (Mann 1945 and Sen 1968)
- Zhang (Zhang 2000)
- Yue and Pilon (Yue et al 2002)

Figure 2.4 presents the outcome of the reanalysis for the hypothetical example site presented in Figure 2.1 through Figure 2.3. Each regression method has a statistical significance value over 95%; however, this may not always be the case and the meaning of that is described further in next section.

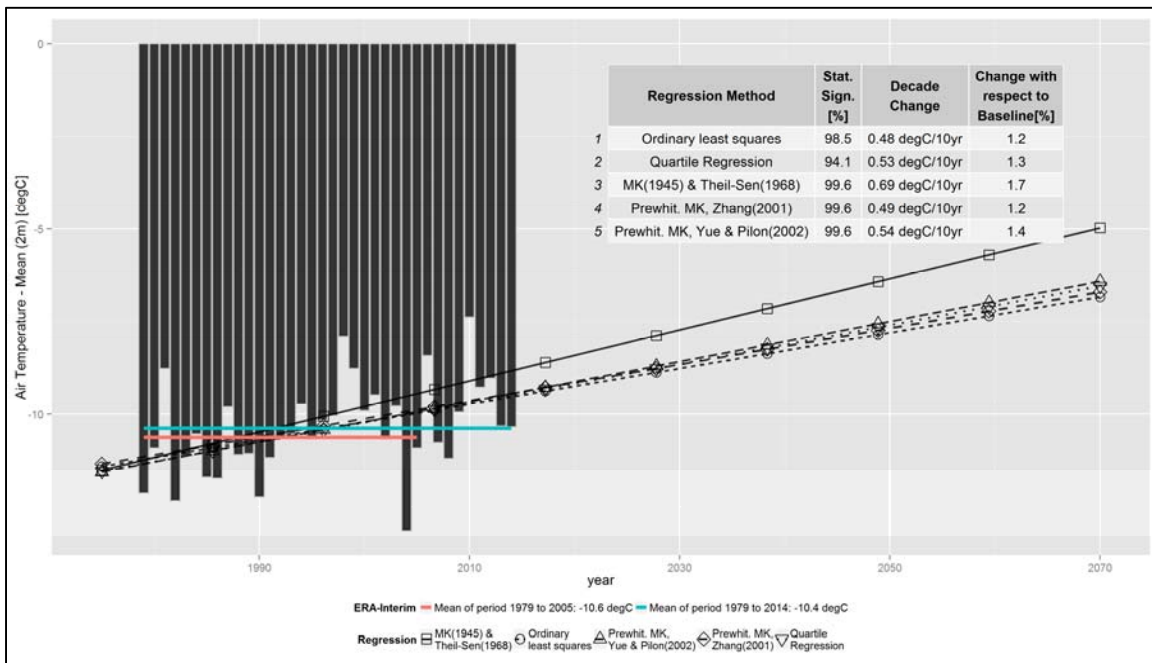

Figure 2.4: Trend analysis outcome based on reanalysis evaluation for hypothetical site presented in Figure 2.1

2.4 Recommended Climate Change Design Parameter

Following completion of the previously described procedure, a design recommendation for each identified climate change parameter is presented. The previous procedure produces two outcomes as follows:

- Outcome 1 is a cumulative probability curve representing change relative to baseline conditions based on the Step 2 analysis; this is also represented by Figure 2.3.
- Outcome 2 is the five separate regression analysis results from the Step 3 trend analysis, again representing change relative to baseline conditions represented by Figure 2.4. The statistical significance of each regression analysis is calculated during this step and must yield a value greater than 95% to be deemed statistically significant.

If the trend analysis shows no regression of statistical significance (i.e. greater than 95%), the climate change design parameter is the 50% cumulative probability value based on the Step 2 baseline analysis. If on the other hand, one or more of the trend analyses suggest trends of statistical significance, the climate change parameter is the maximum of either the 50% cumulative probability value based on the Step 2 baseline analysis, or the mean of all the trend analysis values with statistical significance. Equation 2.2 provides an expression for this criteria.

Equation 2.2

Recommended Climate Change Design Parameter

$$= \text{Maximum}(50\% \text{ Cumulative Probability}, \text{Mean} \{ \text{Regression}_{Stat. \text{Sign} \geq 95\%} \})$$

3 Climate Change Projections

3.1 Long Term Temperature Trends

The mean annual air temperature at Minto is expected to increase by about 3.3°C over the next century (Table 3.1), with mean annual air temperatures of -0.8°C, 0.2°C, and 1.1°C in the 2020s, 2050s and 2080s, respectively. These predictions compare well with those presented by other studies. The International Panel on Climate Change (IPCC) projects a 5°C to 6°C increase in the temperature in Northern Canada for 2100 relative to the 1980 to 1999 temperatures (IPCC 2007).

Table 3.1 though Table 3.8 present additional temperature related climate forecasts for the Minto area. These tables predict longer periods with high temperatures and consequently shorter periods with lower temperatures and less inter-annual temperature variation.

Table 3.1: Mean Annual Air Temperature at Minto

Timeline	Context	Value (°C)	Change Over Baseline (°C)	Change [%]
1979-2005	Baseline	-2.12	-	-
1979-2014	Current Reality	-2.29	-0.17	-0.06%
2011-2040	2020s	-0.82	1.30	0.48%
2041-2070	2050s	0.24	2.36	0.87%
2071-2100	2080s	1.13	3.25	1.20%

Table 3.2: Mean Maximum Air Temperature at Minto

Timeline	Context	Value (°C)	Change Over Baseline (°C)	Change [%]
1979-2005	Baseline	1.39	-	-
1979-2014	Current Reality	1.26	-0.13	-0.05%
2011-2040	2020s	1.40	0.01	0.36%
2041-2070	2050s	1.40	0.01	0.69%
2071-2100	2080s	1.41	0.02	1.10%

Table 3.3: Mean Minimum Air Temperature at Minto

Timeline	Context	Value (°C)	Change Over Baseline (°C)	Change [%]
1979-2005	Baseline	-5.46	-	-
1979-2014	Current Reality	-5.68	-0.22	-0.08%
2011-2040	2020s	-5.49	-0.03	0.48%
2041-2070	2050s	-5.51	-0.05	0.93%
2071-2100	2080s	-5.54	-0.08	1.40%

Table 3.4: Intra-Annual Temperature Range at Minto⁽¹⁾

Timeline	Context	Value (°C)	Change Over Baseline (°C)	Change [%]
1979-2005	Baseline	61.3	-	-
1979-2014	Current Reality	62.2	0.9	0.27%
2011-2040	2020s	59.8	-1.5	-0.45%
2041-2070	2050s	58.6	-2.7	-0.81%
2071-2100	2080s	57.6	-3.7	-1.10%

Note(s):

(1) The difference between the highest temperature of the year and the lowest temperature of the year.

Table 3.5: Daily Minimum Air Temperature, 90th Percentile at Minto

Timeline	Context	Value (%)	Change Over Baseline (%)	Change [%]
1979-2005	Baseline	10.0	-	-
1979-2014	Current Reality	10.2	0.2	2.0%
2011-2040	2020s	14.6	4.6	46.0%
2041-2070	2050s	21.0	11.0	110.0%
2071-2100	2080s	31.0	21.0	210.0%

Table 3.6: Growing Season Length⁽¹⁾ at Minto

Timeline	Context	Value (days)	Change Over Baseline (days)	Change [%]
1979-2005	Baseline	93	-	-
1979-2014	Current Reality	95.9	2.9	3%
2011-2040	2020s	115.3	22.3	24%
2041-2070	2050s	136.7	43.7	47%
2071-2100	2080s	147.9	54.9	59%

Note(s):

(1) Growing season length is the number of days between the first five consecutive days of the year with a mean air temperature above 5°C, and the last five such days of the year.

Table 3.7: Heat Wave Duration Index⁽¹⁾ at Minto

Timeline	Context	Value (days)	Change Over Baseline (days)	Change [%]
1979-2005	Baseline	108	-	-
1979-2014	Current Reality	110	2.0	2%
2011-2040	2020s	143	34.6	32%
2041-2070	2050s	185	76.7	71%
2071-2100	2080s	270	162.0	150%

Note(s):

(1) The maximum period for the year of at least five consecutive days with the maximum air temperature at least 5°C warmer than the daily climatology baseline.

Table 3.8: Frost Days⁽¹⁾ at Minto

Timeline	Context	Value (days)	Change Over Baseline (days)	Change [%]
1979-2005	Baseline	225	-	-
1979-2014	Current Reality	225	0.0	0.0%
2011-2040	2020s	216	-9.5	-4.2%
2041-2070	2050s	207	-18.5	-8.2%
2071-2100	2080s	196	-29.3	-13.0%

Note(s):

(1) Total number of days with an absolute minimum temperature less than 0°C.

3.2 Long Term Precipitation Trends

The total precipitation at Minto is forecasted to increase 67.9 mm (15%) during the mine life (2011 to 2040) and 199.3 mm (44%) by 2100 (Table 3.9).

Table 3.9: Total Precipitation at Minto

Timeline	Context	Value (mm)	Change Over Baseline (mm)	Change [%]
1979-2005	Baseline	453	-	-
1979-2014	Current Reality	469	16.0	4%
2011-2040	2020s	521	67.9	15%
2041-2070	2050s	584	131.4	29%
2071-2100	2080s	652	199.3	44%

3.3 Frequency of Drought

Climate change model suggests that consecutive dry days will decrease by up to 13% by 2100 (Table 3.10). The clear mean annual temperature increase trend (Table 3.1) along with the increasing precipitation trend (Table 3.9) and decreasing consecutive dry day trend (Table 3.10) suggest that the frequency of drought should be decreasing.

Table 3.10: Consecutive Dry Days⁽¹⁾ at Minto

Timeline	Context	Value (days)	Change Over Baseline (days)	Change [%]
1979-2005	Baseline	17.1	-	-
1979-2014	Current Reality	17.8	0.7	4.1%
2011-2040	2020s	16.0	-1.1	-6.4%
2041-2070	2050s	15.2	-1.9	-11.0%
2071-2100	2080s	14.9	-2.2	-13.0%

Note(s):

(1) Maximum number of consecutive dry day is a year. Days with less than 1 mm of precipitation are considered dry days.

3.4 Frequency of Rainfall

The simple daily precipitation intensity index is the mean annual precipitation divided by the total number of wet days. Therefore, the total number of wet days can be estimated from the simple daily precipitation intensity index values and the total precipitation.

The simple daily precipitation intensity index at Minto is forecasted to increase by 6.6% during the mine life and by 25% in the next century (Table 3.11).

Table 3.12 presents the estimated number of wet days. The total estimated number of wet days is forecasted to increase by a similar amount with a 7.9% increase during the mine life and a 15.2% increase during the next century.

Table 3.11: Simple Daily Precipitation Intensity Index⁽¹⁾ at Minto

Timeline	Context	Value (mm/year)	Change Over Baseline (mm/year)	Change [%]
1979-2005	Baseline	3.9	-	-
1979-2014	Current Reality	3.95	0.05	1.28%
2011-2040	2020s	4.16	0.26	6.60%
2041-2070	2050s	4.41	0.51	13.00%
2071-2100	2080s	4.88	0.98	25.00%

Note(s):

(1) The total annual precipitation divided by the total number of wet days in a year

Table 3.12: Estimated Total Number of Wet Days⁽¹⁾ at Minto

Timeline	Context	Value (days)	Change Over Baseline (days)	Change [%]
1979-2005	Baseline	116.2	-	-
1979-2014	Current Reality	118.7	2.6	2.2%
2011-2040	2020s	125.3	9.2	7.9%
2041-2070	2050s	132.6	16.4	14.2%
2071-2100	2080s	133.8	17.7	15.2%

Note(s):

(1) The total number of wet days is not directly developed from the R analysis, but rather calculated based on the values in Table 3.9 and Table 3.11.

3.5 Long Duration Rainfall

Long duration rainfall, fraction of annual precipitation greater than 95th percentile, is predicted to increase by 96% over the next century at Minto (Table 3.13). The number of days with more than 10 mm of rainfall is forecasted to increase by 140% (Table 3.14).

The change in days with more than 10 mm of rain is forecasted to be 58% respectively during mine life (2011 to 2040). Similarly the maximum total precipitation for a five day period will increase by 20% over the next century and 7.8% over the mine life (2011 to 2040) as shown in

Table 3.15. Therefore, the volume and frequency of high precipitation events will tend to increase over the century.

Table 3.13: Fraction of Annual Precipitation >95th Percentile⁽¹⁾ at Minto

Timeline	Context	Value (%)	Change Over Baseline (%)	Change [%]
1979-2005	Baseline	5.01	-	-
1979-2014	Current Reality	5.29	0.28	5.59%
2011-2040	2020s	7.01	2.00	40.00%
2041-2070	2050s	7.52	2.51	50.00%
2071-2100	2080s	9.82	4.81	96.00%

Note(s):

(1) Percentage of days with precipitation greater than the 95th percentile calculated for wet days from the baseline period.

Table 3.14: Days with Precipitation Greater Than or Equal to 10 mm at Minto

Timeline	Context	Value (days)	Change Over Baseline (days)	Change [%]
1979-2005	Baseline	3.88	-	-
1979-2014	Current Reality	4.3	0.38	9.79%
2011-2040	2020s	6.1	2.25	58.00%
2041-2070	2050s	7.7	3.84	99.00%
2071-2100	2080s	9.3	5.43	140.00%

Table 3.15: Greatest Five Days Total Rainfall at Minto

Timeline	Context	Value (mm)	Change Over Baseline (mm)	Change [%]
1979-2005	Baseline	38.9	-	-
1979-2014	Current Reality	40.2	1.3	3.3%
2011-2040	2020s	41.9	3.0	7.8%
2041-2070	2050s	43.6	4.7	12.0%
2071-2100	2080s	46.7	7.8	20.0%

3.6 Short Duration Rainfall

Based on an evaluation of the predicted values for greatest five-day total precipitation, consecutive dry days, simple daily intensity index, days with rain greater than 10 mm, and fraction of total annual precipitation greater than the 95th percentile, the IDF for Minto was adjusted, where the total precipitation increase is forecasted to increase by 44% in 2100. Using the current reality, the values for the respective return periods and durations were increased by 44% to reflect the forecasted increase

Table 3.16: IDF Adjusted for Total Precipitation Increase by 2100

Duration		Return Periods [years]						
Minutes	Hours	2	5	10	25	50	100	200
5	0.08	7.9	10.3	12.0	14.0	15.5	17.0	18.7
10	0.17	10.5	13.7	16.0	18.5	20.5	22.5	24.8
15	0.25	12.3	16.1	18.7	21.7	24.0	26.4	29.0
30	0.5	14.6	19.1	22.2	25.8	28.6	31.4	34.5
60	1	16.7	21.8	25.4	29.5	32.7	35.8	39.5
120	2	19.1	25.0	29.1	33.8	37.4	41.1	45.2
360	6	22.7	29.7	34.6	40.2	44.5	48.8	53.7
720	12	27.4	35.8	41.7	48.5	53.7	58.9	64.8
1440	24	33.8	43.2	49.2	56.6	61.8	67.1	68.5

3.7 Snow Accumulation

Estimations of snow accumulation were developed by coupling the climate change model predictions for precipitation, temperature, and wind speed with the energy snowmelt model by Walter et al. (2005).

To estimate snowmelt, a subroutine from the EcoHydrology library in R, called SnowMelt was used to analyze snow melt from an energy-based model. This program function forecasts the future daily snowmelt using energy--based model posed by Walter et al. (2005). This hydrological

model is based on typical meteorological parameters (e.g. daily maximum, minimum temperature, wind speed, and total precipitation).

These inputs were obtained on a sub-daily and daily scale from the reanalysis source ERA-Interim from 1979 to 2015. As a terrain source, the model required latitude and longitude of the site, topographical slope, and aspect of the terrain. These last two parameters were obtained from the topographical information GTopo30. This source provides a worldwide topographical information with a spacing of 30 arc-sec which is approximately equal to 1 km.

The result of the model is a daily snowmelt model including parameters such as snowfall water equivalent, snowmelt, snowpack depth, and snow water equivalent of snowpack.

The monthly average snow depth at Minto is expected to increase from over the next century (Table 3.17). In the time periods 1979 to 2005 and 1979 to 2014, the snowpack depth will tend to increase with the time to a maximum in the 2100s. These snowpack values should be taken as a reference as snowmelt model should be calibrated with site information.

Table 3.17: Monthly Average Snowpack at Minto

Timeline	Snow Depth (mm)											
	Jan	Feb	Mar	Apr	May	Jun	Jul	Aug	Sep	Oct	Nov	Dec
1979-2005	230	260	240	220	30	0	0	10	30	100	160	180
1979-2014	240	260	260	230	40	0	0	10	30	110	170	210
2011-2040	270	280	280	230	30	0	0	0	20	100	180	230
2041-2070	290	300	280	210	20	0	0	0	10	90	190	240
2071-2100	330	330	300	200	10	0	0	0	10	90	210	280

3.8 Snowmelt

The daily maximum snowmelt in an average year at Minto can be seen in Table 3.18, the month in which these maximum values are obtained from can be seen in Table 3.19. These predictions forecast freshet in April, and slightly increasing maximum daily snowmelt over the next century. The predicted maximum daily snowmelt in 2071 to 2100 is similar that of the snowmelt 1979 to 2005 (Table 3.18).

Table 3.18: Maximum Daily Snowmelt in Average Year at Minto

Timeline	Daily Maximum Snowmelt (mm/day)
1979-2005	20
1979-2014	20
2011-2040	22
2041-2070	23
2071-2100	22

Table 3.19: Daily Maximum Snowmelt per Month at Minto

Timeline	Snow Melt (mm/day)											
	Jan	Feb	Mar	Apr	May	Jun	Jul	Aug	Sep	Oct	Nov	Dec
1979-2005	4	4	6	20	0	0	0	0	1	6	4	4
1979-2014	3	4	6	20	0	0	0	0	0	5	3	4
2011-2040	4	6	9	22	0	0	0	0	0	5	4	4
2041-2070	5	7	13	23	0	0	0	0	0	3	4	5
2071-2100	5	9	16	22	0	0	0	0	0	3	4	6

3.9 Wind Speed

The mean annual wind speed at Minto is predicted to increase by 2.4% over the next century (Table 3.20).

Table 3.20: Mean Wind Speed at Minto

Timeline	Context	Value (m/s)	Change Over Baseline (m/s)	Change [%]
1979-2005	Baseline	2.56	-	-
1979-2014	Current Reality	2.55	-0.01	-0.39%
2011-2040	2020s	2.56	0.00	0.01%
2041-2070	2050s	2.58	0.02	0.87%
2071-2100	2080s	2.62	0.06	2.40%

4 Benchmarking

The climate change projections were benchmarked against the following reports with climate projections:

- Yukon Climate Change Indicators and Key Findings 2015** (NCEC 2015). The report is designed to provide an overview of the trends in temperature, precipitation, fire severity, and sea ice extent/volume for decision makers in the province. The temperature and precipitation trends can be used as a comparative for the climate change value evaluated in this report.
- Coffee Gold Project, Climate Change Projection for Coffee Creek Region, Yukon** (Lorax 2015). The report is designed to address climate projections and their potential impacts on the project. They address temperature, precipitation and freeze and thaw dates, which can be used as a comparative for the climate change projections evaluated in this report.

Projected mean annual temperature, precipitation and freezing days all exhibit similar values. The NCEC report uses historical trends to predict the future outcomes. Coffee Gold's report uses global climate models, while this report uses both. Lorax (2015) in the Coffee Gold report uses five downscaled model averages climate change models. SRK's methodology does not use downscaled climatic model models, instead considered gridded information for all the available climate change models and compared those results applied to the site with historical trends from Reanalysis ERA-Interim.

The expected mean annual temperature presents similar trend in all of three reports. Freezing-day estimations are also quite similar in Coffee Gold's report and to SRK's. MAP shows an increasing trend in all reports; SRK's report presents a greater increase than either of the two benchmark reports. However, the magnitude seems reasonable compared with the benchmarked reports. Table 4.1 presents an overall synthesis of the climate change results in the area.

Table 4.1: Climate Change Benchmarks – Meteorological Parameters

Projected Parameter	Period [years]	NCEC Yukon, 2015	Lorax -Coffee Gold, 2015	SRK – Minto, 2016
Mean Annual Temperature	2060's	>+2 °C		+2.4 °C ¹
	2100's		+3-5 °C	+3.3 °C
Mean Annual Precipitation	2060's	+10-20%		+ 29% ¹
	2100's		+20%	+44%
Freezing Days	2060's	N/A		-18.5 Days ¹
	2100's		-30 Days	-29 Days

Note(s):

(1) Value defined for 2050s.

For IDF benchmarking the site IDF was compared with Simonovic et al's (Western University – London, ON) IDF CC tool (2016). They provide a web evaluation of all the IDF curves in Canada under different time frames and for a wide variety of climate change scenarios. The IDF information from the closest EC meteorological station of Pelly Ranch located 25 km north of the site was used from this web page as a comparison to the site IDF.

The climate change timeframe used in all of the scenarios is 2071 to 2100. Simonovic et al. (2016) provide IDF values for three representative concentration pathway (RCP) scenarios: RCP 2.6, RCP 4.5 and RCP 8.5. Table 4.2 provides a summary of the IDF changes for the Site (SRK) versus Pelly Ranch (Simonovic et. al., 2016) based on baseline conditions. The table shows that the SRK value falls within the higher range of the values presented by Simonovic et al. However, the value is within a reasonable range considering the uncertainty associated to these climate change models.

Table 4.2: Climate Change Benchmarks – Intensity Duration Frequency Curves

Source	RCP 2.6 (2071-2100)	RCP 4.5 (2071-2100)	RCP 8.5 (2071-2100)	Compiled (2071-2100)
IDF CC Tool – Pelly Ranch, 2016	+20%	+26%	+47%	
SRK – Minto, 2016				+44%

5 Summary of Overall Climate Change Trends

Climate change effects develop over very long timescales relative to the project life. As such the trends listed in Table 5.1 will manifest as minimal increases and decrease over the length of the Project.

Table 5.1: Overall Climate Change Trends

Climate Factor	Trend	Justification
Mean Annual Temperature	Increasing	The mean annual temperature should increase in total 3.3 degrees Celsius for the period 2100's.
Frequency of Extreme Temperatures	Reduction of variability	The intra-annual temperature range will decrease with the time, range between extreme maximum and minimum temperatures.
Frequency of Rainfall	Increasing	The IDF will increase in 44% for the period 2100s. This is also complemented with an increase in the amount of wet days in a year.
Total Rainfall	Increasing	Increase in total precipitation of 199.3 mm (44%) by 2100's.
Snow Accumulation	Increasing	Snow depth appears to be increasing between December and March mainly by years 2100s.
Snowmelt	Unknown	There is a predicted increase in the daily maximum snowmelt, however the values are not monotonically increasing with the time; and the variation magnitude is close to 10%, which suggest some uncertainty.
Floods and Storms	Unknown, likely Increasing	Increasing temperature, precipitation, long duration rainfall and storm intensities in the trends to 2100 suggest that storms and freshet are increasing. Therefore it is likely reasonable to assume that storms and floods will increase by the period of 2100's.

6 Effects of Climate Change on Closure Design Criteria

The climate change projections discussed in this memo and specifically summarized in Section 5 contribute to develop a long-term design criteria for engineered closure designs and infrastructure. For closure conveyance channel designs the predicted increase in precipitation and in the frequency of storms play a considerable role in engineering channel geometries and riprap specifications. According to the climate change study, channels which are designed on the present day discharges are projected to more water in the form of a greater peak flow, greater and more frequent storm runoffs, and even freshets flow.

SRK Consulting (Canada) Inc.

Original Signed By

Victor Muñoz S., MEng, PEng

and reviewed by

Original Signed By

Dylan MacGregor, MAsc, PGeo

Disclaimer—SRK Consulting (Canada) Inc. has prepared this document for Minto Explorations Ltd.. Any use or decisions by which a third party makes of this document are the responsibility of such third parties. In no circumstance does SRK accept any consequential liability arising from commercial decisions or actions resulting from the use of this report by a third party.

The opinions expressed in this report have been based on the information available to SRK at the time of preparation. SRK has exercised all due care in reviewing information supplied by others for use on this project. Whilst SRK has compared key supplied data with expected values, the accuracy of the results and conclusions from the review are entirely reliant on the accuracy and completeness of the supplied data. SRK does not accept responsibility for any errors or omissions in the supplied information, except to the extent that SRK was hired to verify the data.

7 References

- [CRAN] Comprehensive R Archive Network. 2015. Download, source code for the language R. Website: <https://cran.r-project.org/>.
- Engineers Canada, March 2013. PIEVC Engineering Protocol for Infrastructure Vulnerability Assessment and Adaptation to a Changing Climate – Principles and Guidelines, Revision PG-10.1.
- [EC] Environment Canada. 2015. The Canadian Regional Climate Model (CRCM), website: <http://www.ec.gc.ca/ccmac-cccma/default.asp?lang=en&n=82DD0FCC-1>.
- [ECMWF] European Centre for Medium-Range Weather Forecast. 2015. Era Interim. Website: <http://www.ecmwf.int/en/research/climate-reanalysis/era-interim>.
- [IPCC] Intergovernmental Panel on Climate Change. 1995. IPCC Second Assessment Climate Change 1995. A report of the intergovernmental panel on climate change.
- [IPCC] Intergovernmental Panel on Climate Change. 2001: Climate Change 2001: Synthesis Report. A Contribution of Working Groups I, II, and III to the Third Assessment Report of the Intergovernmental Panel on Climate Change [Watson, R.T. and the Core Writing Team (eds.)]. Cambridge University Press, Cambridge, United Kingdom, and New York, NY, USA, 398 pp.
- [IPCC] Intergovernmental Panel on Climate Change. 2007. Climate Change 2007: Synthesis Report. Contribution of Working Groups I, II and III to the Fourth Assessment Report of the Intergovernmental Panel on Climate Change [Core Writing Team, Pachauri, R.K and Reisinger, A. (eds.)]. IPCC, Geneva, Switzerland, 104 pp.
- [IPCC] Intergovernmental Panel on Climate Change. 2014. Climate Change 2014: Synthesis Report. Contribution of Working Groups I, II and III to the Fifth Assessment Report of the Intergovernmental Panel on Climate Change [Core Writing Team, R.K. Pachauri and L.A. Meyer (eds.)]. IPCC, Geneva, Switzerland, 151 pp.
- Koenker RW, and Bassett GW. 1978. Regression quantiles, *Econometrica*, Vol N°46, 33–50.
- Lorax. 2015. Coffee Gold Project – Climate Change Projections for Coffee Creek Region, Yukon.
- Maidment D. 1993. *Handbook of Hydrology*. McGraw-Hill.
- Mann HB. 1945. Non-parametric tests against trend, *Econometrica* Vol N°13:163-171.
- [NCEC] Northern Climate ExChange. 2015. Yukon Climate Change Indicator and Key Findings 2015.
- Sen PK. 1968. Estimates of the Regression Coefficient Based on Kendall's Tau. *Journal of the American Statistical Association* Vol. 63, No. 324: 1379-1389.

- Simonovic, Slobodan, Roshan Srivastav, Andre Schardong, and Dan Sandink. 2016. "IDF CC Tool for deriving rainfall intensity-duration-frequency curves for future climate scenarios." <http://idf-cc-uwo.ca>.
- Walter, MT, Brooks ES, McCool DK, King LG, Molnau M, and Boll J. 2005. Process- based snowmelt modeling: Does it require more input data than temperature-index modeling? *Journal of Hydrology*. 300 (2005) pp. 65- 75.
- [WMO] World Meteorological Organization. 2007. The Role of Climatological Normals in a changing climate. WCDMP-No 61.
- Yue S, Pilon P, B. Phinney and G. Cavadias, 2002. The influence of autocorrelation on the ability to detect trend in hydrological series. *Hydrological Processes*, 16: 1807-1829.
- Zhang X, Vincent LA, Hogg WD, and Niitsoo A. 2000. Temperature and Precipitation Trends in Canada during the 20th Century. *Atmosphere-Ocean* 38(3): 395-429.

Appendix D – Channel Routing Options Evaluation

Memo

To:	Ryan Herbert, Minto Explorations Ltd	Client:	Minto Explorations Ltd.
From:	Samantha Barnes, SRK	Project No:	1CM002.042
Cc:	Dylan McGregor, SRK	Date:	August 3, 2016
Subject:	Minto Channel Routing Options Evaluation		

1 Introduction

This memo summarizes the impacts of routing runoff through the pit versus diverting it around the pit. The Minto routing flow closure evaluation assessed channel design options for surface water flow received by the Main and Area 2 open pits.

Flow routing alternatives include two options for the Area 2 Pit:

- Option 1 – Area 2 Pit upstream flow are routed into Area 2 Pit through Channel B (Ditch B Phase V/VI Design). From the pit, the flows are discharged through channel width, which becomes Channel D.
- Option 2 – Area 2 Pit catchment is diverted into Channel B (Ditch B), which by-passes the Area 2 Pit.

Three 24 hours precipitation return period models were applied to three geometric channel configurations for the Main Pit and options 1 and 2 for the Area 2 Pit.

2 Hydraulic – Hydrologic Model

Three 24 hours precipitation return period events were modelled to test the change in resultant peak flow and flow depth in the discharge channel design: a 2-year peak flow, a 200-year peak flow, and a probable maximum flood (PMF). Three geometries were assessed for discharge channels from both open pits as follows:

- Case 1 – Minimum channel width (2 m)
- Case 2 – Constructible channel width, based on dozer sizing (7 m)
- Case 3 – Maximum channel width, based on topography (22 m for Main Pit, 15 m for Area 2 Pit)

Geometric models of each routing alternative and each channel width alternative were compared using HEC-HMS developed by US Army Corps of Engineers (2000).

3 Results

3.1 Routing Options – Hydrologic Results

Figure 1 shows the complete hydrograph for Option 1 and Option 2. The blue solid line is the routing and channel width alternative (Option 1). The red dashed line is the diversion alternative (Option 2). Figure 2 shows a close-up of this variation in peak flow under both scenarios. The difference between the two routing options is approximately 30 m³/s for the PMF event.

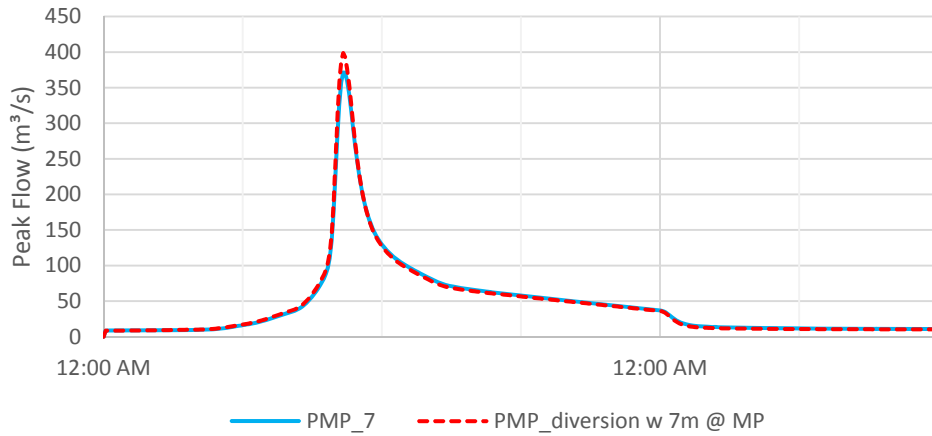

Figure 1: Routing Option Comparison for the PMF

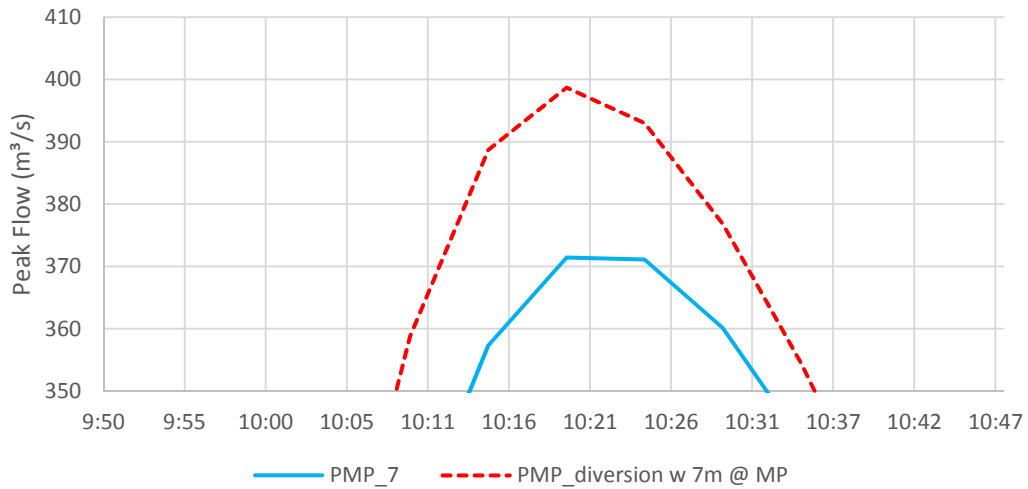

Figure 2: Routing Option Comparison for the PMF (Flow Peak Close-up)

3.2 Geometric Cases – Hydraulic Results

The results for the three channel width cases are presented in Table 1 where the design peak flow events are assumed to be the PMP. The riprap was sized based on the Isbash method (Garcia 2007).

Table 1: Probable Maximum Flood Results

Channel Width Scenario	Area 2 Pit			Main Pit		
	Peak Flow (m ³ /s)	Flow Depth (m)	Riprap D50 (m)	Peak Flow (m ³ /s)	Flow Depth (m)	Riprap D50 (m)
Case 1 (2m)	5.8	0.99	0.08	17.4	1.71	0.30
Case 2 (7m)	9.7	0.79	0.09	23	1.31	0.32
Case 3 (max)	14	0.64	0.07	31.9	0.86	0.17

4 Discussion and Recommendations

The results of the two routing options illustrate a minimal difference in impact from diverting runoff around the Area 2 Pit as opposed to through the pit. Furthermore, the diversion Option 2 does not result in a difference in the magnitude of peak flow or the period of time when the peak is presented when compared to routing flows through the pit. For the channel width options to minimize the size of riprap required, Case 2 is recommended for both open pit channel widths.

Based on the analyses presented and considering future construction riprap needs, it is recommended that the Option 1 channel alignment and the Case 2 channel width option be implemented. Option 1 represents the routine option with the lowest flows and it is paired with the channel geometry that requires the most conservative riprap sizing.

SRK Consulting (Canada) Inc.

Original Signed By

Samantha Barnes, EIT
Consultant

Disclaimer—SRK Consulting (Canada) Inc. has prepared this document for Minto Explorations Ltd. Any use or decisions by which a third party makes of this document are the responsibility of such third parties. In no circumstance does SRK accept any consequential liability arising from commercial decisions or actions resulting from the use of this report by a third party.

The opinions expressed in this report have been based on the information available to SRK at the time of preparation. SRK has exercised all due care in reviewing information supplied by others for use on this project. Whilst SRK has compared key supplied data with expected values, the accuracy of the results and conclusions from the review are entirely reliant on the accuracy and completeness of the supplied data. SRK does not accept responsibility for any errors or omissions in the supplied information, except to the extent that SRK was hired to verify the data.

5 References

Garcia M. 2007. Sedimentation Engineering - Processes, measurements, modeling and practice. ASCE Manuals and reports on engineering practice No 110. Virginia: ASCE.

US Army Corps of Engineers. 2000. "Hydrologic Modeling System - HEC-HMS - Technical Reference Manual."

Appendix E – Integrating Vegetation Erosion Protection

Memo

To:	Ryan Herbert, Minto Explorations Ltd.	Client:	Minto Explorations Ltd.
From:	Stuart McPhee, EIT	Project No:	1CM002.042
Cc:	Dylan MacGregor, SRK	Date:	August 3, 2016
Subject:	Integrating Vegetation Erosion Protection		

This memo discusses the use of vegetation to assist channel stabilization and erosion reinforcement of disturbed soils for the Minto Project. Best management practices (BMPs) are provided in the Yukon Revegetation Manual for Practical Approaches and Methods (Matheus 2013) and the Government of Alberta's Transportation Erosion and Sediment Control Manual (2011). These BMP's provide guidelines for analysis, design selection, construction, and maintenance of erosion, and sediment control structures and site-specific selection of vegetation and establishing plant communities.

A commonly employed reclamation practice is to use live vegetation for channel protection and erosion control of disturbed soils. The use of biotechnical techniques do not replace the need for rock riprap, but can complement and improve channel stabilization designs during construction (e.g. regraded slopes and rock riprap). These techniques also improve soil reinforcement on disturbed slopes and regraded areas and ultimately assist in establishing vegetation, riparian zones, and develop soils.

The vegetation proposed for channel stabilization and erosion control focus on the use of coarse woody, grass and legume, and wetland species of vegetation. These species are widely used in industrial site reclamation design, construction, and maintenance to mitigate erosion, and sedimentation. The Yukon Revegetation Manual summarizes common plant species that are established by seeding. Common seeding practices for reclamation include hydroseeding and broadcast seeding. Appended to this memo are the summary tables prepared in the Yukon Revegetation Manual *Chapter 5: Revegetation Scenarios and Seed Recommendations*. Included in the appended tables are both Non-Native (Agronomical) and Locally-Collected (Native) seeds and the reclamation scenario's that they are suited for.

Methods to improve existing and proposed infrastructure (e.g. conveyance channels, covers and disturbed erodible slopes) include:

- establish vegetation and restorative self-sustaining plant communities;
- increase slope and channel stability due to root reinforcement, interlock, and soil draining;
- provide protection against wind, water, and surface erosion and rock fall;

- provide shade to regulate temperature and humidity close to surface that promotes further vegetation growth of volunteer species;
- provide improvement to the soil water regime through interception, evapotranspiration, and storage;
- improve soil development and the formation of organic soils;
- improve habitat provisions for animals;
- may reduce construction and maintenance costs (compared to other designs); and
- establish post closure landscapes that are often more appealing due to their more natural features.

At this stage of closure design, a preliminary assessment of common biotechnical reclamation practices has identified that there is a future opportunity to integrate vegetation erosion protection into the closure conveyance channel design and the disturbed soils adjacent to the channels.

There are three main components to the design and construction of the closure conveyance channels that would benefit from biotechnical stabilization BMPs:

- Disturbed and excavated slopes
- Establishing riparian vegetation
- Channel erosion and protection

Closure designs for conveyance channels will require sections of channels to have excavated alignments through erodible materials. The excavated slopes within these materials will typically have slopes graded towards the channel. It is expected that if these disturbed slopes are left, they will erode and even transport sediment into the channels. If the slopes contain weak fine grained erodible soils, then the slopes may be subject to sloughing and larger scale transportation of materials, which may block the conveyance channels.

Immediately after construction the closure conveyance channels will lack riparian vegetation. Biotechnical techniques can assist with slope stabilization and establishing riparian vegetation. Techniques for stabilizing these slopes are recommended to be a combination of BMPs provided in the Government of Alberta's Transportation Erosion and Sediment Control Manual (2011) as listed in Table 1. The BMP figure for live staking method is attached to this memo as an example.

Table 1: Selected Closure BMPs from Alberta Transportation Erosion and Sediment Control Manual

BMP ID	BMP Name	Disturbed and Excavated Slopes	Riparian Vegetation Development	Channel Erosion Protection
13b	Rolled Erosion Control Products	✓		
14a,b	Riprap Armouring	✓		✓
19a,b	Slope Drains	✓	✓	
24a	Hydroseeding	✓	✓	

BMP ID	BMP Name	Disturbed and Excavated Slopes	Riparian Vegetation Development	Channel Erosion Protection
27a	Live Staking	✓	✓	✓
27b1,2,3	Brush Layering	✓	✓	✓
28	Wattle (Live Fascine)	✓	✓	
34a	Surface Roughening	✓	✓	
34c	Slope Benching	✓		
38a,b,c	Coir/Straw Rolls with Brush Layers	✓	✓	
39	Brush Mattress	✓	✓	
40	Live Siltation		✓	✓
41	Willow Post and Pole	✓	✓	✓
44	Vegetated MSE	✓	✓	✓
45a,b,c,d	Vegetated Riprap	✓	✓	✓

SRK Consulting (Canada) Inc.

Original Signed By

Stuart McPhee, EIT

Original Signed By

Victor Muñoz S., MEng, PEng

and reviewed by

Original Signed By

Dylan McGregor, MAsc, PGeo

Disclaimer—SRK Consulting (Canada) Inc. has prepared this document for Minto Explorations Ltd.. Any use or decisions by which a third party makes of this document are the responsibility of such third parties. In no circumstance does SRK accept any consequential liability arising from commercial decisions or actions resulting from the use of this report by a third party.

The opinions expressed in this report have been based on the information available to SRK at the time of preparation. SRK has exercised all due care in reviewing information supplied by others for use on this project. Whilst SRK has compared key supplied data with expected values, the accuracy of the results and conclusions from the review are entirely reliant on the accuracy and completeness of the supplied data. SRK does not accept responsibility for any errors or omissions in the supplied information, except to the extent that SRK was hired to verify the data.

1 References

Government of Alberta. 2011. Erosion and Sediment Control Manual. AB. Recovered July 28, 2016 from <http://www.transportation.alberta.ca/Content/docType372/Production/ErosionControlManual.pdf>

Matheus P, and Omtzigt T. 2013. Yukon Revegetation Manual – Practical Approaches and Methods. Recovered July 28, 2016 from: <http://www.yukonrevegetationmanual.ca/>.

Attachment 1: Revegetation Scenarios and Seed Recommendations

Summary of Recommended Species

Table 5.27

NON-NATIVE HERBACEOUS SPECIES (COMMERCIAL SEEDS) AND APPLICABLE SCENARIOS

SCENARIO		1	2	3	4	5	6	7
SPECIES (cultivar)	# OF SEEDS/KG	LOW SLOPE, LOW-MID ELEVATION SITES	STEEP SLOPES	WET SITES	HIGHWAY RIGHT-OF-WAYS	DISTURBED PERMAFROST SITES	ARCTIC TUNDRA AND STABLE PERMAFROST SITES	ALPINE AND SUBALPINE SITES
Rocky Mountain fescue <i>Festuca saximontana</i> (common)	1,430,000	x	x		x	x		x
Violet wheatgrass <i>Elymus alaskanus</i> (common)	330,000	x	x		x		x	x
Glaucous bluegrass <i>Poa glauca</i> (Tundra or common)	2,904,000	x	x		x		x	x
Slender wheatgrass <i>Elymus trachycaulus</i> (Revenue, Adanac, Highlander or common)	349,800	x	x		x			
Ticklegrass <i>Agrostis scabra</i> (common)	11,000,000	x				x		x
Tufted hairgrass <i>Deschampsia caespitosa</i> (Nortran or common)	3,300,000	x		x	x	x	x	x
Fowl bluegrass <i>Poa palustris</i> (common)	4,840,000	x		x	x	x		
Spike trisetum <i>Trisetum spicatum</i> (common)	5,500,000						x	x
Bluejoint reedgrass <i>Calamagrostis Canadensis</i> (Sourdough or common)	8,442,438	x		x		x		
Polargrass <i>Arctagrostis latifolia</i> (Alyeska or common)	3,960,000			x		x	x	
American sloughgrass <i>Beckmannia syzigachne</i> (Egan or common)	2,723,600			x		x		
Alpine bluegrass <i>Poa alpina</i> (Gruening or common)	2,353,826						x	x

Summary of Recommended Species

Table 5.28

NON-NATIVE HERBACEOUS SPECIES (COMMERCIAL SEEDS) AND APPLICABLE SCENARIOS

SCENARIO		1	2	3	4	5	6	7
SPECIES (cultivar)	# OF SEEDS/KG	LOW SLOPE, LOW-MID ELEVATION SITES	STEEP SLOPES	WET SITES	HIGHWAY RIGHT-OF-WAYS	DISTURBED LOWLAND PERMAFROST SITES	ARCTIC TUNDRA AND STABLE PERMAFROST SITES	ALPINE AND SUBALPINE SITES
Kentucky bluegrass <i>Poa pratensis</i> (Nugget)	3,057,648			x			x	
Creeping red fescue <i>Festuca rubra</i> (Arctared for northern Yukon, Boreal for southern Yukon)	539,407	x	x		x	x	x	x
Canada bluegrass <i>Poa compressa</i> (Reubens or common)	5,264,204	x	x	x	x	x		
Streambank wheatgrass <i>Elymus lanceolatus</i> (Sodar)	336,600	x	x	x	x	x	x	
Meadow foxtail <i>Alopecurus pratensis</i> (common)	895,136	x	x	x	x	x	x	
Red top <i>Agrostis gigantea</i> (common)	10,672,640	x		x				
Timothy <i>Phleum pratense</i> (Climax, Engmo)	2,559,400			x		x	x	
Alfalfa <i>Medicago sativa</i> (Rangelander, Rambler or Peace)	498,960		x					
Sheep fescue <i>Festuca ovina</i> (common)	1,100,000	x			x	x	x	x
Annual rye <i>Lolium multiflorum</i>	477,400		x			x		
Barley <i>Hordeum vulgare</i>	29,920		x			x	x	x



Summary of Recommended Species

Table 5.29

LOCALLY-COLLECTED NATIVE HERBACEOUS SPECIES (SEEDS) AND APPLICABLE SCENARIO

SCENARIO		1	2	3	4	5	6	7
SPECIES	# OF SEEDS/KG	LOW SLOPE, LOW-MID ELEVATION SITES	STEEP SLOPES	WET SITES	HIGHWAY RIGHT-OF-WAYS	DISTURBED LOWLAND PERMAFROST SITES	ARCTIC TUNDRA AND STABLE PERMAFROST SITES	ALPINE AND SUBALPINE SITES
Northern rough fescue <i>Festuca altaica</i>	451,854	x	x	x	x	x	x	
Yukon wheatgrass <i>Elymus calderi</i>	—	x						
Macroum's wheatgrass <i>Elymus macrourus</i>	374,782	x	x					
Northern brome <i>Bromus pumpellianus</i>	202,400	x	x		x			
Sweetgrass <i>Hierochloë hirta</i> (formerly <i>H. odorata</i>)	242,000	x	x		x			
Alpine sweetgrass <i>Hierochloë alpina</i>	—						x	x
Mountain timothy <i>Phleum alpinum</i> (formerly <i>P. commutatum</i>)	—					x		x
Northern bluegrass <i>Poa alpigena/Poa pratensis</i>	3,057,648			x		x	x	x
Arctic bluegrass <i>Poa arctica</i>	3,250,553						x	
Nuttall's alkaligrass <i>Puccinellia nuttalliana</i>	4,648,140	x	x	x	x	x	x	x
Yellow locoweed <i>Oxytropis campestris</i>	521,400	x			x			
Showy locoweed <i>Oxytropis splendens</i>	1,548,800	x			x			
Bear root <i>Hedysarum alpinum</i>	154,000	x						
Mackenzie's hedysarum <i>Hedysarum Mackenzii</i>	101,889	x						
Yarrow <i>Achillea millefolium</i> and <i>Achillea sibirica</i>	6,274,426	x			x			
Mountain avens <i>Dryas</i> spp.	—	x			x	x	x	x
Arctic lupine <i>Lupinus arcticus</i>	22,733	x		x	x	x	x	x
Wormwood/sage <i>Artemesia</i> spp.	—	x	x		x		x	x

Summary of Recommended Species

Table 5.30

LOCALLY-COLLECTED WOODY SPECIES AND APPLICABLE SCENARIOS

SCENARIO	1	2	3	4	5	6	7
	LOW SLOPE, LOW-MID ELEVATION SITES	STEEP SLOPES	WET SITES	HIGHWAY RIGHT-OF-WAYS	DISTURBED LOWLAND PERMAFROST SITES	ARCTIC TUNDRA AND STABLE PERMAFROST SITES	ALPINE AND SUBALPINE SITES
LOCAL WOODY SPECIES							
Willow <i>Salix alaxensis, S. pulchra, S. planifolia, S. richardsonii, S. hastate, S. arbusuloides, S. lucida, S. pseudomyrsinites</i> (the two best species are <i>S. alaxensis</i> and <i>S. pulchra</i>)	x		x		x	x	x
Poplar <i>Populus balsamifera</i>	x		x				
Shrub birch <i>Betula glandulosa</i>	x		x			x	x
Dwarf birch <i>Betula nana</i>						x	
Green alder <i>Alnus crispa</i>	x		x			x	x
Grey alder <i>Alnus tenuifolia</i>	x		x				



Attachment 2: Live Staking BMP Technique

TYPICAL USE OF WILLOW STAKES TO ANCHOR WILLOW WATTLES, STRAW ROLLS, BIO MATS, OR TURF REINFORCEMENT MATS

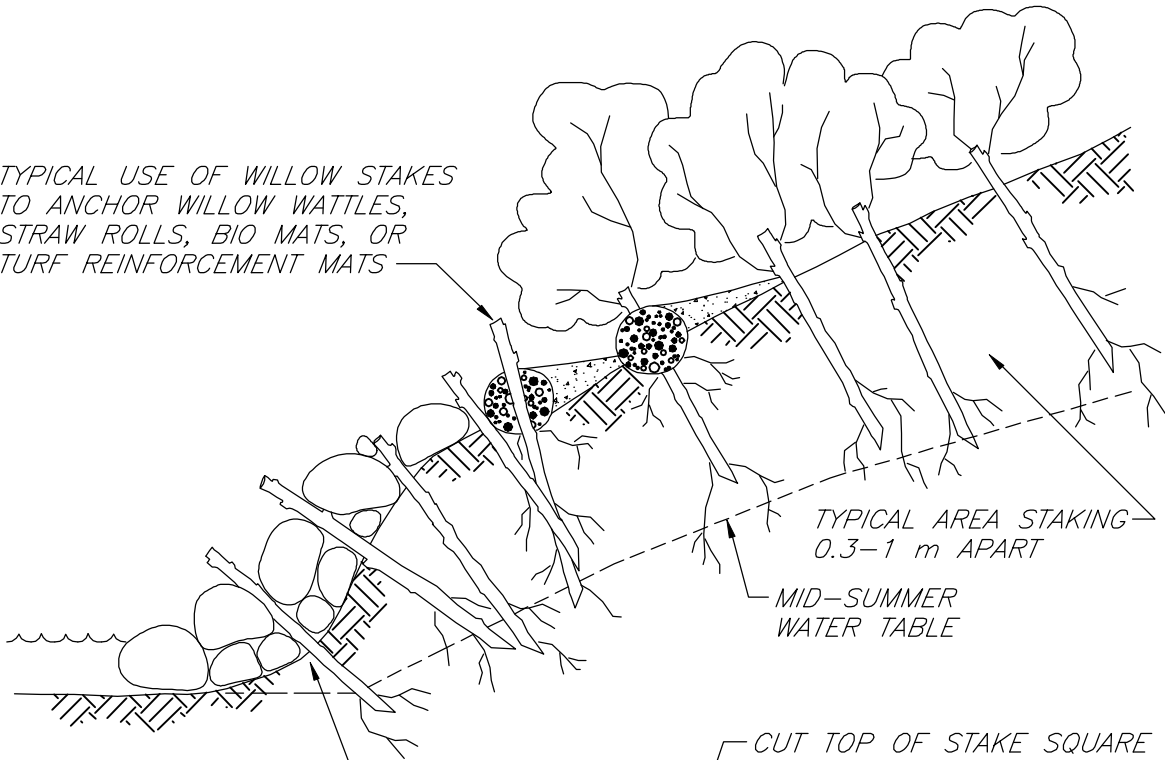

TYPICAL AREA STAKING
0.3-1 m APART

MID-SUMMER
WATER TABLE

TYPICAL - DRIVE OR PLANT WILLOW STAKES THROUGH OPENINGS IN RIPRAP OR GABIONS

PLANT 80% OF STAKE LENGTH INTO THE GROUND

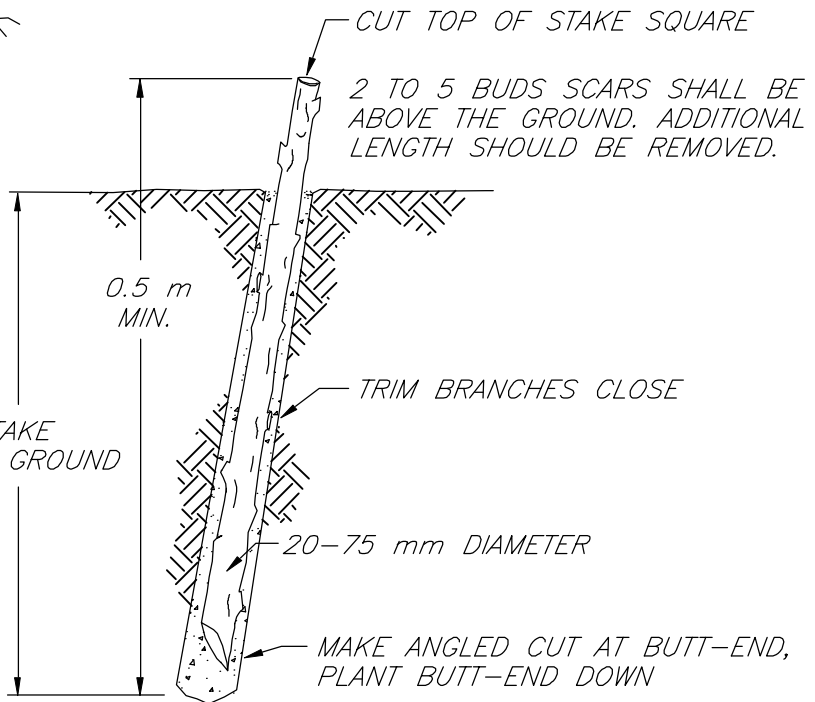

CUT TOP OF STAKE SQUARE

2 TO 5 BUDS SCARS SHALL BE ABOVE THE GROUND. ADDITIONAL LENGTH SHOULD BE REMOVED.

0.5 m
MIN.

TRIM BRANCHES CLOSE

20-75 mm DIAMETER

MAKE ANGLED CUT AT BUTT-END, PLANT BUTT-END DOWN

NOTES:

1. HARVEST AND PLANT STAKES DURING THE DORMANT SEASON.
2. USE HEALTHY, STRAIGHT AND LIVE WOOD AT LEAST 1 YEAR OLD.
3. MAKE CLEAN CUTS AND DO NOT DAMAGE STAKES OR SPLIT ENDS DURING INSTALLATION, USE A PILOT BAR IN FIRM SOILS.
4. SOAK CUTTINGS FOR 24 HOURS (MIN.) PRIOR TO INSTALLATION.
5. TAMP THE SOIL AROUND THE STAKE.
6. THIS FIGURE IS PROVIDED FOR GUIDANCE ONLY AND DOES NOT CONSTITUTE A DESIGN. A SITE SPECIFIC DESIGN IS REQUIRED FROM DESIGNER/ENGINEER.

NOT TO SCALE

LIVE STAKING

From: Salix-Applied Earthcare - EROSION DRAW 3.0
1996 JOHN MCCULLAH



FILE: LIVESTK